

GPS Vehicle Tracker

User Guide

(Version V2.1)

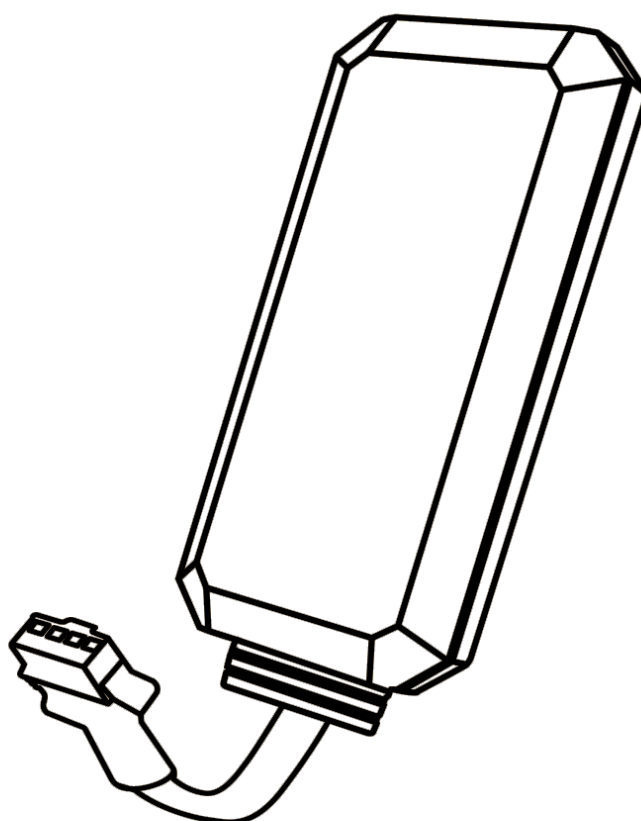

At a Glance

1.1 Overview

1.2 Accessories

Power cable/Relay/Microphone/SOS alarm Button

1.3 Wiring Diagram

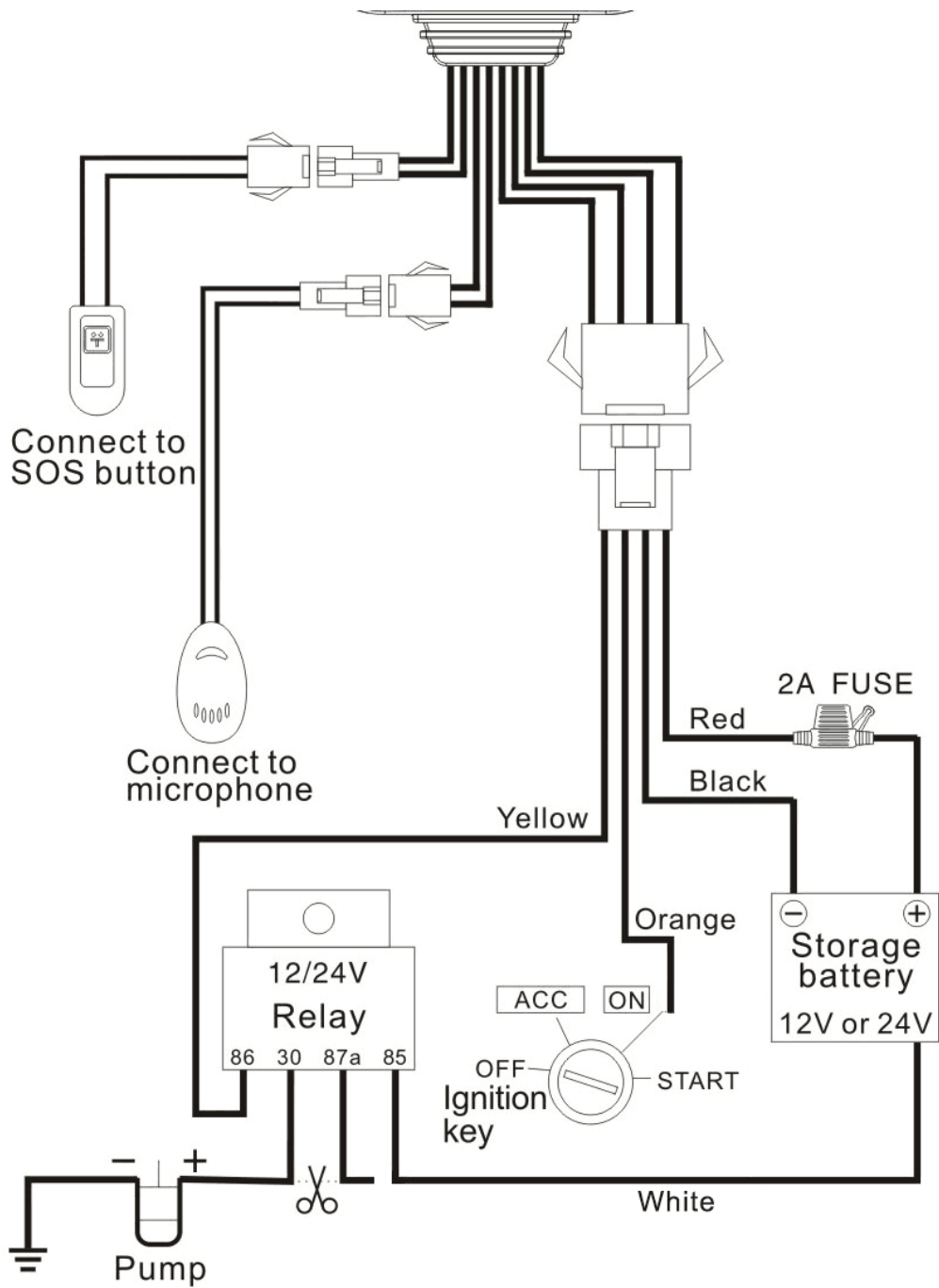

2

Getting Started

2.1 Installing the SIM card

Important: 1 A SIM card is required in order to use cellular services when connecting to GSM networks.

2 Keep the SIM card GPRS availability

3 Note down the SIM card phone numbers which is device contacting numbers.

Open the side plug, install the SIM card in the right direction, turn on the device.

2.2 Setting up and activating the device

To set up and activating the device, you should send SMS to device numbers by mobile phone.

Setting server

SMS: `SERVER,1,vt.protrack365.com,8842,0#`

2.3 Installing the device

2.3.1 Connect according wires to your car by referring to [Wiring Diagram in Chapter 1.3](#)

2.3.2 Install the device in following three suggested place:

Important: 1 Make it covert for security factors.

2 Keep away from high power electrical devices, such as reversing radar, anti-theft device or other vehicle communication equipment which may affect the device signal.

3 Keep the device front face up & No metallic cases above the device which may affect signal as well. Such as the windshield which is pasted with metal thermal-protective coating or heating coating.

3

Checking location

3.1 Via SMS

WHERE#

3.2 Via tracking platform

www.protrack365.com

Ask your distributor for log-in account and password.

4

Basic

4.1 LED indication

4.1.1 Red LED -Power status

Slow flashing	Normal working (backup battery)
Solid bright	Normal working (external power supplying)
Off	Power off

4.1.2 Green LED -GSM status

Quick flashing	GSM initialization
Slow flashing	Normal working with GSM network
Off	No GSM signal

4.1.3 Blue LED -GPS status

Quick flashing	Searching GPS signal
Slow flashing	Normal working with GPS fixed
Off	No GPS fixed

4.2 Power/ACC/Tele-cutoff (petrol/electricity) control line (4 pin)

4.2.1 The standard voltage is 9V-36VDC. Please use the power line which provided by the manufacturer. The red line is the positive. The black line is the negative. The negative should earth alone or link iron during installing. Do not connect it to other ground wire.

4.2.2 ACC line (orange) is connected to the ACC switch of the vehicle. Please make sure to connect the ACC line. The tracker will decide whether to enter ignition detection according to ACC status. If do not connect to ACC line, the device will enter ignition detection status. If the vehicle vibrates when moving, it will activate the vibration alarm. If there is no need for the theft proof function, connect the ACC line to the positive in parallel and keep high level.

4.2.3 Tele-cutoff (petrol/ electricity) control line (yellow) is connected to pin 86 of the Tele-cutoff (petrol/ electricity) relay (equal to the yellow line of the relay socket).

4.3 Input and Output cable (3 pin)

Firmware updating interface/expanded function to reserve space.

4.4 MIC line (2 pin)

Externally connect to microphone for voice monitor function

4.5 SOS line (2 pin)

Externally connect to SOS switch for SOS function.

Alarm management

5

*When any kinds of alarms happened, device will send alarm SMS&CALL SOS numbers.

5.1 Vibration Alarm

When ACC is off and some vibration happened, device will alarm.

5.2 Cut-off alarm

When external power is cut, device will alarm.

5.3 Geo-fence alarm

After setting geo-fence range, if the device comes in & out the range, it will alarm.

5.4 Low-power alarm

When external power is cut, device will keep working with its backup battery and when its battery is too low, device will alarm.

5.5 Movement alarm

When ACC is off, if the vehicle is moved, device will alarm.

Note: For other alarm setting and parameter setting, please check the command list provided by the supplier.

Trouble shooting

6

6.1 When device in the background display not on-line or off-line, First observe the device 3 indicator is normal, according to the device lights status to judge device work condition, if the red light flashes, the green light is not bright, please check

that the SIM card is installed correctly, if the installation is no problem, please replace the SIM card test again. Under no condition to observe the situation, use mobile phone dial SIM card device number, if not connect successful, indicating that the device Area is no GSM signal or signal is weak, please try it again in a good signal place; if the device is insufficient balance or out of service, Please try again after recharge; if connect successful, please consult the appropriate operator if SIM card is open GPRS function; if not connected, prompt power off ,please check that the device is installed properly.

6.2 When the GPS signal reception abnormal, please take it into the broad place positioning, general first positioning need 1-2 minutes. If a long time does not positioning, please check the device installation location if meets the requirements, the normal installation without metal shielding.

6.3 When the GSM signal reception abnormal, please check the device SIM card is installed correctly; or the location may not cover GSM signal (such as a basement), please use in the place where signal coverage.

6.4 When power-up, the red power light is off, please check the wiring is correct, and after exclude the internal device problem then can power-up again.

Warning Statement

This equipment has been tested and found to comply with the limits for a Class B digital device, pursuant to part 15 of the FCC Rules. These limits are designed to provide reasonable protection against harmful interference in a residential installation. This equipment generates, uses and can radiate radio frequency energy and, if not installed and used in accordance with the instructions, may cause harmful interference to radio communications. However, there is no guarantee that interference will not occur in a particular installation. If this equipment does cause harmful interference to radio or television reception, which can be determined by turning the equipment off and on, the user is encouraged to try to correct the interference by one or more of the following measures:

- Reorient or relocate the receiving antenna.
- Increase the separation between the equipment and receiver.
- Connect the equipment into an outlet on a circuit different from that to which the receiver is connected.
- Consult the dealer or an experienced radio/TV technician for help.

Caution: Any changes or modifications to this device not explicitly approved by manufacturer could void your authority to operate this equipment.

This device complies with part 15 of the FCC Rules. Operation is subject to the following two conditions: (1) This device may not cause harmful interference, and (2) this device must accept any interference received, including interference that may cause undesired operation.

To comply with FCC RF exposure compliance requirements, this grant is applicable to only mobile configurations. The antennas used for this transmitter must be installed to provide a separation distance of at least 20 cm from all persons and must not be co-located or operating in conjunction with any other antenna or transmitter.

Maintain Information

Customer Name: _____

Tel: _____

Add: _____

IMEI: _____

Purchase Date: _____

Maintain Records

Date	Problem Description	Records	Debug Engineer