

IBM Ethernet Switch B24X

IBM System x at-a-glance guide

The IBM Ethernet Switch B24X is a compact, high-performance, high-availability, and high-density 10 GbE solution that meets mission-critical data center and High Performance Computer (HPC) requirements. It can support 1 GbE servers until they are upgraded to 10 GbE-capable Network Interface Cards (NICs), simplifying migration to 10 GbE server farms.

In addition, the B24X is a fully featured switch with IPv4 Layer 3 capabilities that can provide cost-efficient 10 GbE network aggregation for 1 GbE access switches. The switch runs a feature-rich and mature IronWare Operating System with an industry-standard command-line interface (CLI), minimizing re-training and operational costs. Supporting a full range of Request for Comments (RFC) and Institute of Electrical and Electronics Engineers (IEEE) standards for interoperability, along with compatibility for vendor-specific protocols such as Cisco Discovery Protocol (CDP) and Per-VLAN Rapid Spanning Tree Plus (PVRST+), the B24X integrates seamlessly into existing network infrastructures.

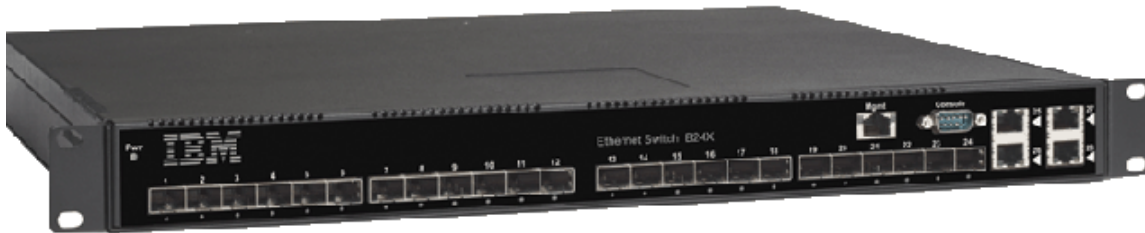

Figure 1. IBM Ethernet Switch B24X (front view)



Figure 2. IBM Ethernet Switch B24X (back view)

Did you know

The IBM Ethernet Switch B24X is the most power-efficient 10 Gbps switch in its class at 176 watts per twenty-four 10 GbE ports. This saves customers up to 56% in power and cooling costs over competing switches. In addition, the high-performance, cut-through, full-mesh non-oversubscribed (1:1) architecture of the B24X offers up to twice the performance with lower latencies and uses up to 2 - 3 times less rack space.

The no-compromise B24X also features data center class network resiliency and hardware availability features to support non-stop networking, making the switch ideal as an all-purpose Top of Rack switch

providing network connectivity to servers within a rack, or as a compute node interconnect in HPC environments. Complemented by a full Ethernet and IP product portfolio available from IBM System Networking, IBM B24X can also be part of a standardized network infrastructure running on the proven IronWare Operating System.

Part number information

Table 1 lists the orderable part numbers for the B24X and associated options through System x.

Table 1. IBM part numbers and feature codes for ordering

Description	Part number	Feature code
IBM Ethernet Switch B24X	0563-012	0563-HC5
300 W AC Power Supply (for 1+1 redundancy)	69Y0373	4774
10 GbE 300 m, SFP+, 10GBASE-SR (duplex LC, MMF, 850 nm, OM)	69Y0389	6416

Note: OM = Optical Monitoring supported. SMF = single-mode fiber. MMF = multi-mode fiber. MMF distance supported depends on cabling type. Use OM3 50 im (2000 MHz*km) MMF to support the farthest distances.

IBM Ethernet Switch B24X (0563-012 / 0563-HC5) ships with the following:

- One IBM Ethernet Switch B24X, which includes:
 - Twenty-four 10/1 GbE SFP+ ports plus four 10/100/1000 MbE RJ-45 ports
 - One out-of-band 10/100/1000 MbE RJ-45 management port
 - One DB9 male serial console port
 - One hot-swappable triple-fan tray
 - One (of two) 300 W AC hot-swappable power supply
- One 1.5 m DB9 female-to-DB9 female straight-through serial console cable
- Rack mount brackets for mounting into an EIA-310D compliant rack
- *IBM Ethernet Switch x-series Installation and User Guide*
- Statement of limited warranty
- Brocade end user license agreement
- Safety and regulatory notices
- CD-ROM with manuals and environmental notices

Note: Qualified SFP+ or SFP transceivers are required for each SFP+ port and are not included.

Power cords are not included and must be specified at the time of order. The B24X has a C14 inlet to receive a C13 power plug. Table 2 lists the available power cable options.

Table 2. Power cord options

Description	Part number
Line cord - 2.8 m, 10A/230V, C13 to CEE7-VII (Europe)	39Y7917
Line cord - 2.8 m, 10A/250V, C13 to DK2-5a (Denmark)	39Y7918
Line cord - 2.8 m, 10A/250V, C13 to SEV 1011-S24507 (Swiss)	39Y7919
Line cord - 2.8 m, 10A/250V, C13 to SI 32 (Israel)	39Y7920
Line cord - 2.8 m, 10A/250V, C13 to SABS 164 (S. Africa)	39Y7922
Line cord - 2.8 m, 10A/250V, C13 to BS 1363/A (UK)	39Y7923
Line cord - 2.8 m, 10A/250V, C13 to AS/NZ 3112 (Australia/NZ)	39Y7924
Line cord - 2.8 m, 220-240V, C13 to KETI (S. Korea)	39Y7925
Line cord - 2.8 m, 10A/250V, C13 to (2P+Gnd) (India)	39Y7927
Line cord - 2.8 m, 220-240V, C13 to GB 2099.1 (China)	39Y7928
Line cord - 2.8m, 125V, C13 to NBR 6147 (Brazil)	39Y7929
Line cord - 2.8 m, 10A/250V, C13 to IRAM 2073 (Australia)	39Y7930
Line cord - 4.3 m, 10A/125V, C13 to NEMA 5-15P (US)	39Y7931
Line cord - 4.3 m, 10A/100-250V, C13 to IEC 320-C14	39Y7932
Line cord - 1.5 m, 10A/100-250V, C13 to IEC 320-C14	39Y7937

Each SFP+ optical transceiver, such as the 10GBASE-SR SFP+, requires fiber optic cabling with duplex LC connectors to connect to another optical transceiver. See the “Network cabling requirements” section for additional details.

Each 10/100/1000 MbE RJ-45 port or the 1 GbE copper SFP transceiver (1000BASE-T) requires copper CAT 5e or higher cabling for connectivity. Table 3 lists the available copper cable options.

Table 3. Ethernet copper cable (RJ-45) options

Description	IBM part number
0.6 m Ethernet cable (blue)	40K5679
1.5 m Ethernet cable (blue)	40K8785
3 m Ethernet cable (blue)	40K5581
10 m Ethernet cable (blue)	40K8927
25 m Ethernet cable (blue)	40K8930

Additional options are available through IBM System Networking HVEC channels. Table 4 lists the orderable part numbers for these additional options.

Table 4. IBM part numbers and feature codes for ordering (System Networking HVEC)

Description	IBM part number	IBM feature code
10 GbE Direct Attach SFP+, 1 m, Active TwinAx copper cable	45W2398	2711
10 GbE Direct Attach SFP+, 3 m, Active TwinAx copper cable	45W2408	2731
10 GbE Direct Attach SFP+, 5 m, Active TwinAx copper cable	45W3039	2751
1 GbE 100 m SFP, 1000BASE-T (RJ-45, connects to CAT5 or higher cabling)	45W2813	2202
1 GbE 550 m SFP, 1000BASE-SX (duplex LC, MMF, 850 nm, OM)	45W2815	2211
1 GbE 10 km SFP, 1000BASE-LX (duplex LC, SMF, 1310 nm, OM)	45W2816	2212
1 GbE 70 km SFP, 1000BASE-LHA (duplex LC, SMF, 1550 nm, OM)	45W2817	2213
10 GbE 10 km, SFP+, 10GBASE-LR (duplex LC, SMF, 1310 nm, OM)	45W4264	2131

Note: OM = Optical Monitoring supported. SMF = single-mode fiber. MMF = multi-mode fiber. MMF distance supported depends on cabling type. Use OM3 50 im (2000 MHz*km) MMF to support the farthest distances.

The B24X has twenty-four dual-speed 10/1 GbE SFP+ ports enabling customers to seamlessly transition their 1 GbE devices to 10 GbE speeds by upgrading the transceiver. Qualified SFP+ or SFP transceivers are required for each SFP+ port and are not included. Up to twenty-four 10 GbE SFP+ or 1 GbE SFP transceivers are supported on each IBM Ethernet Switch B24X.

10 GbE SFP+ optical -SR (10GBASE-SR) transceivers support distances up to 300 m, which is ideal for connectivity within a data center. 10 GbE SFP+ optical -LR (10GBASE-LR) transceivers support extended distances up to 10 km.



Figure 3. SFP+/SFP optical transceiver - Receives duplex LC connectors

For cost-effective server connectivity within a rack, 10 GbE copper direct attach SFP+ active TwinAx cables are available. These cables have two 10 GbE SFP+ transceivers attached on either end of the cable and have been tested for compatibility with the Brocade 10Gb CNA, QLogic 10Gb CNA, and Emulex 10Gb Virtual Fabric Adapter for IBM System x. Compatibility with other 10 GbE server adapters and network devices is up to the user to determine.



Figure 4. 10 GbE Direct Attach SFP+ TwinAx cable

Features and benefits

The features and benefits are:

- Comprehensive standards support: Supporting a wide range of open IEEE and RFC standards, the B24X is fully interoperable with existing network environments. In addition, the B24X supports vendor-specific protocols such as Cisco Discovery Protocol (CDP), native support for Per-VLAN Rapid Spanning Tree Plus (PVRST+), and static trunks to EtherChannel for further supportability.
- Built for the data center: The B24X features front-to-back airflow, allowing installation into racks with a hot-cold aisle design without the need for complicated air baffles. All ports are found on the front side of the switch for easy serviceability.
- Flexible deployment: Dynamic Layer 3 routing allows the B24X to support multiple deployment options, including a Top of Rack access switch supporting inter-VLAN routing within a rack or a cost-effective aggregation switch.
- High availability: Hot-swappable and redundant power supplies and fan trays reduce downtime and allow you to meet your service level agreements by increasing switch availability.
- Best-in-class power efficiency: At only 176 W per twenty-four 10 GbE ports, the low power consumption reduces operational costs tied to power and cooling and allows data centers running out of power to deploy more assets.
- High performance: Supporting full-line rate traffic on all ports with no over-subscription and 488 Gbps of internal forwarding performance, the B24X also uses an advanced cut-through forwarding architecture featuring low latencies to support time-sensitive applications such as real-time video and market trading/exchange applications.
- Industry-standard CLI: Minimize re-training and personnel costs while increasing operational efficiencies by utilizing a management interface with which the network team is already familiar.
- Mature operating system: The feature-rich and time-tested IronWare Operating System running on the B24X and all IBM b-type system networking devices provides a consistent experience across the network.
- Upgrade without rip-and-replace: With dual-speed 10/1 GbE SFP+ ports plus four additional 1 GbE RJ-45 ports, the B24X supports a mix of 10 GbE and 1 GbE servers on the same switch without needing to force upgrades of existing systems.

- Granular network visibility: Hardware-based sFlow v5 provides packet sampling for analysis, trending, and application of automated policies based on thresholds using industry applications such as Brocade Ironview Network Manager.
- Cost competitive: The B24X includes all software capabilities and a 3-year warranty of the base product, simplifying ordering while being priced extremely competitively compared with other vendors.

Specifications

The IBM Ethernet Switch B24X supports the following specifications when running IronWare R04.2.x and higher. Be aware that Layer 3 capabilities are supported on IronWare R04.2.x and higher, and further details can be found by navigating the IBM Support website:

http://www.ibm.com/support/entry/portal/Overview/Hardware/Systems/System_x/Network_Solutions/0563

- Form-factor
 - 1 RU; 43.5 cm (17.1 in.) width x 4.28 cm (1.7 in.) height x 39.4 cm (15.5 in.) depth
 - Rack-mount into 19" EIA-310D compliant rack, Telco rack, or table-top
- Ports (data)
 - Twenty-four dual-speed 10/1 GbE SFP+ ports
 - Four 10/100/1000 MbE RJ-45 ports
- Ports (management, out-of-band)
 - One 10/100/1000 MbE RJ-45 port
 - One DB9 male serial console port
- Power supplies, fans, and airflow
 - Two 300 W AC hot-swappable power supplies supported for 1+1 redundancy (base switch comes with one)
 - One hot-swappable fan tray with three 2+1 redundant fans
 - Front-to-back airflow supporting data center hot-cold aisle deployments
- Performance
 - 488 Gbps line speed full-duplex throughput
 - 363 Mpps forwarding capacity
 - 1.5 micro-second latency
- Jumbo frames
 - Supported: up to 9216-byte Ethernet frame sizes
- Media (transceivers)
 - 10 GbE SFP+ -SR transceivers and direct attach copper TwinAx cables available
- VLANs
 - Up to 4096 maximum VLANs
 - 802.1Q tagging
 - 802.1Q-in-Q tagging
 - Dual-mode VLANs (tagged and untagged traffic across same port)
 - Port-based VLANs
 - VLAN groups
 - Private VLANs

- Link aggregation
 - Up to eight links per group, 28 link groups per switch
 - Static trunks compatible with Cisco EtherChannel
 - 802.3ad Link Aggregation Control Protocol (LACP) for dynamic trunk groups
- Quality of service (QoS) and rate shaping
 - Eight queues per port with strict priority (SP), weighted round robin (WRR), and combined SP/WRR schedulers
 - 802.1p Class of Service (CoS)
 - IP DSCP/DiffServ (Type of Service) to priority mapping
 - ACL, port, and static MAC address to priority mapping
 - Layer 2 CoS and Layer 3 DSCP re-marking
 - Outbound rate shaping
- Layer 2
 - Up to 32,000 MAC addresses.
 - Per-VLAN Rapid Spanning Tree Protocol Plus (PVST/PVST+/PVRST+) compatibility in default configuration supports smooth implementation into Cisco Layer 2 environments.
 - 802.1d Spanning tree Protocol (STP).
 - 802.1w Rapid Spanning Tree Protocol (RSTP).
 - 802.1s Multiple Spanning Tree Protocol (MSTP) enables multiple STP instances and forwarding paths for more efficient traffic distribution.
 - Virtual Switch Redundancy Protocol (VSRP) alternative to STP and includes sub-second convergence and Layer 2 redundancy based on the VRRPE protocol.
 - Metro Ring Protocol (MRP) v1/v2 enables fast, sub-second convergence in ring topologies. IGMPv1/v2/v3 Snooping and PIM-SM Snooping reduce multicast flooding in a Layer 2 network.
 - Root Guard prevents rogue devices from hijacking STP root.
 - BPDU Guard prevents rogue devices from participating in STP.
 - DHCP Assist helps DHCP servers respond correctly to devices in a different subnet than the DHCP server.
- Layer 3
 - Up to 12,000 IPv4 routes
 - Routing Information Protocol (RIP) v1/v2
 - Open Shortest Path First (OSPF) v2
 - Internet Group Management Protocol (IGMP) v1/v2/v3
 - Protocol Independent Multicast Dense Mode (PIM-DM) v1/v2 and Sparse Mode (PIM-SM) v2
 - Equal Cost Multi Path (ECMP) for load balancing across up to eight paths
 - Virtual Router Redundancy Protocol (VRRP) and VRRP-E (Enhanced)

- Security
 - 802.1x authentication, accounting, port security, and dynamic assignment for ACLs, MAC filtering, and VLANs
 - Up to 1,534 inbound, rule-based (hardware-based) access control list (ACL) entries
 - Standard ACLs based on source IP address
 - Extended ACLs based on source and destination IP addresses or IP protocol information
 - Authorization, Authentication, and Accounting (AAA) support on RADIUS, TACACS, and TACACS+
 - Multi-device authentication, which validates and applies security policies based on MAC address information from a RADIUS server
 - AES encryption for SSHv2
 - Denial of Service protection against Smurf (ICMP) and TCP SYN attacks in hardware
- Management
 - Industry-standard CLI via Telnet and SSHv2
 - Fault management integration with IBM Systems Director v6.2
 - Network-wide management of all IBM b-type system networking switches using Brocade Ironview Network Manager (INM)
 - Simple Network Management Protocol (SNMP) v1/v2/v3
 - sFlow v5 for hardware-based packet sampling
 - Ties into industry tools such as Brocade INM and InMon products for trend analysis and automated policy application
 - Remote Monitoring (RMON) protocol
 - Link Layer Discovery Protocol (LLDP), Cisco Discovery Protocol (CDP), and Foundry Discovery Protocol (FDP)
 - Simple Network Time Protocol (SNTP)
 - Firmware image update via TFTP and SCP
- Monitoring
 - Syslog support of up to six Syslog servers for centralized log collection and analysis.
 - Port mirroring of inbound and outbound traffic.
 - Digital optical monitoring monitors power levels and temperatures of optical transceivers and sends an alert if operating out of specification.
 - Temperature monitoring sends alerts if the temperature exceeds a certain threshold and shuts down the device after an extended period of time.
 - Port flap dampening increases network resiliency by limiting the number of port state transitions on an interface.
 - Link Fault Signaling (LFS) detects and reports fault conditions on 10 GbE ports.
 - Uni-Directional Link Detection (UDLD) monitors the link between two devices and brings the port down if the link goes down on either end.

Connectivity options

The B24X supports a wide variety of industry IEEE and RFC standards and should interoperate with any network device that supports industry standard Ethernet connectivity. This includes servers, other Ethernet switches, iSCSI Storage Area Network (SAN) arrays, Network-Attached Storage (NAS) arrays, and other network devices. Figure 5 shows the IBM Ethernet Switch B24X (front view with port labeling).

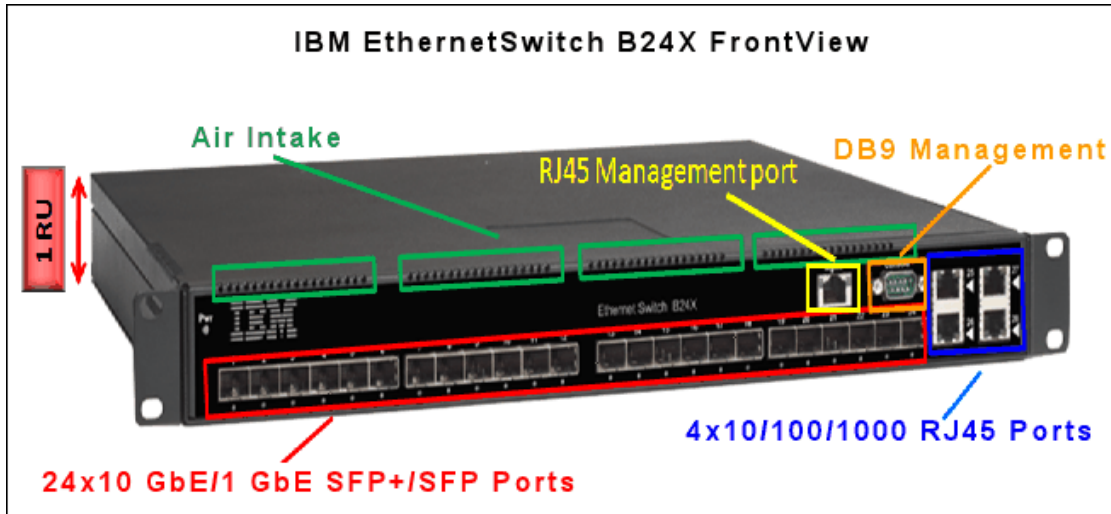

Figure 5. IBM Ethernet Switch B24X (front view with port labeling)

Table 5 lists the methods that the B24X can use to connect to another device.

Table 5. Connectivity options

On the B24X	On the device to be connected
<p>SFP+ port using 10 GbE SFP+ optical transceiver: 69Y0389: 10GBASE-SR</p> <p>This optical transceiver receives a duplex LC connector.</p>	<p>The optic on the device being connected can be another form-factor (that is, XFP transceiver, X2 module, or integrated into NIC), but must have a matching optical transmission type.</p> <p>For example, a 10GBASE-SR XFP optical transceiver on the device being connected must match a 10GBASE-SR SFP+ optical transceiver on the B24X within the proper wavelength and power specifications.</p> <p>Multi-mode or single-mode fiber as specified required for connectivity. See the "Network cabling requirements" section.</p>
<p>SFP+ port using 10 GbE Direct Attach SFP+ Active TwinAx cable:</p> <ul style="list-style-type: none"> ● 45W2398 or 45W2401: 1 meter ● 45W2408 or 45W2409: 3 meter ● 45W3039 or 45W3042: 5 meter <p>Direct Attach Cables (DACs) are copper cables with two SFP+ transceivers attached to either end of the cable.</p>	<p>It is up to the user to decide whether the interface on the device being connected supports the IBM DAC used with the B24X.</p> <p>Below is a list of IBM server adapters that have been tested for compatibility with the part numbers in the left-hand column. If a product is not listed, that does not necessarily mean that it is incompatible--it simply has not been tested.</p> <p>IBM server adapters:</p> <ul style="list-style-type: none"> ● 42C1820: Brocade 10Gb Converged Network Adapter for IBM System x ● 49Y4250: Emulex 10Gb Virtual Fabric Adapter for IBM System x ● 42C1800: QLogic 10 Gb CNA for IBM System x
<p>10/100/1000 MbE RJ-45 port: Auto-sensing, auto-negotiating, auto-MDI/MDIX.</p>	<p>Connect to any RJ-45 port or TX adapter supporting 10, 100, or 1000 Mbps Ethernet over CAT5 or higher cabling up to 100 meters.</p>

Connectivity to IBM System servers

The B24X can be deployed as a Top of Rack access switch to provide connectivity to servers within a rack. This includes servers from IBM System x, System p, and System i. IBM System x servers typically come with on-board 1 Gbps Ethernet RJ-45 ports. Additional 1 GbE NICs can be installed to increase connectivity. These NICs might have RJ-45 ports, SFP ports requiring a transceiver, or integrated optical transceivers. Follow the guidelines in Table 5 for connectivity.

10 Gbps Ethernet connectivity is not standard in most System x servers, and a 10 GbE NIC or 10 GbE CNA must be installed. Only the IBM System x3850/3950 X5 series (except for the ARx model) come standard with a customized Emulex Virtual Fabric Adapter. Table 6 lists the 10 GbE adapters that are available for IBM System x servers.

Table 6. 10 Gbps adapters for IBM System x servers

System x rack and tower server adapter models	x3200 M3	x3250 M3	x3350	x3400 M2	x3400 M3	x3500 M2	x3500 M3	x3350	x3550 M2	x3550 M3	x3620 M3	x3650	x3650 M2	x3650 M3	x3755	x3850/3950 M2	x3850/3950 X5
Brocade 10Gb CNA (42C1820)	N0.226	N	Y	N	Y	N	Y	Y	Y	Y	N	Y	Y	Y	Y	Y	Y
QLogic 10Gb CNA (42C1800)	Y	Y	Y	N	Y	N	Y	Y	Y	Y	N	Y	Y	Y	Y	Y	Y
Emulex Virtual Fabric Adapter (49Y4250)	Y	Y	Y	Y	Y	Y	Y	Y	Y	Y	Y	Y	Y	Y	Y	Y	Y
NetXtreme II 10 GigE Express Fiber SR Adapter (42C1790)	N	N	Y	Y	Y	Y	Y	Y	Y	Y	Y	Y	Y	Y	Y	Y	Y

The Brocade 10Gb CNA [42C1820], QLogic 10Gb CNA [42C1800], and Emulex Virtual Fabric Adapter [49Y4250] each have two SFP+ ports and can be connected to the B24X using:

- The adapter's supported 10GBASE-SR SFP+ transceiver connected to the B24X 10GBASE-SR SFP+ transceiver [69Y0389] over multi-mode fiber cable.
- The Direct Attach SFP+ Active TwinAx copper cables listed in Table 4.

The NetXtreme II 10 GigE Express Fiber SR Adapter (42C1790) has a single integrated 10GBASE-SR optic. This port can be connected to the B24X 10GBASE-SR SFP+ transceiver [69Y0389] over a multi-mode fiber cable.

Connectivity to IBM BladeCenter

The B24X can be deployed as an aggregation switch to provide connectivity between down-stream

switches. This includes IBM System Networking switches, BladeCenter Ethernet embedded switches, and Ethernet switches from other vendors

IBM BladeCenter Ethernet Switch Modules are available with 1 Gbps and 10 Gbps Ethernet uplinks. Table 7 lists the various IBM BladeCenter Ethernet Switch Modules that can be used to connect to the B24X.

Table 7. IBM BladeCenter Ethernet Switch Modules (ESM)

BladeCenter Ethernet Switch Module models	Part #	Ext. 1 GbE ports	Ext. 10 GbE ports	BC H	BC HT	BC E	BC T	BC S
BNT Virtual Fabric 10Gb ESM	46C7191	10 dual-speed SFP+		Y	Y	N	N	N
Cisco Nexus 4001I ESM	46M6071	6 dual-speed SFP+		Y	Y	N	N	N
Cisco Catalyst 3110X ESM	41Y8522	0	1 X2 ¹	Y	Y	Y	Y	N
10Gb Ethernet Pass-Thru Module	46M6181	0	14 SFP+	Y	Y	N	N	N
BNT 1/10Gb Uplink ESM	44W4404	6 RJ-45	3 SFP+	Y	Y	Y	Y	Y
BNT Layer 2/3 Copper ESM	32R1860	6 RJ-45	0	Y	Y	Y	Y	Y
BNT Layer 2/3 Fiber ESM	32R1861	6 SFP	0	Y	Y	Y	Y	Y
BNT Layer 2-7 Gigabit ESM	32R1859	4 RJ-45	0	Y	Y	Y	Y	Y
Cisco Catalyst 3012 ESM	43W4395	4 RJ-45	0	Y	Y	Y	Y	Y
Cisco Catalyst 3110G ESM	41Y8523	4 RJ-45	0	Y	Y	Y	Y	N
Server Connectivity Module	39Y9324	6 RJ-45	0	Y	Y	Y	Y	Y
Intelligent Copper Pass-Thru Module	44W4483	14 RJ-45	0	Y	Y	Y	Y	Y

Note ¹: X2 modules have duplex SC connectors. An SC-to-LC fiber cable is required to connect to a SFP+ transceiver with duplex LC connectors.

For Ethernet Switch Modules with SFP+ or X2 ports see the respective IBM Redbooks at-a-glance guide to locate transceivers supported. Review Table 5 for guidance on how to connect the Ethernet Switch Module to the B24X.

Popular configurations

This section illustrates how the IBM Ethernet Switch B24X can be used in various configurations.

Top of Rack switch

An access or edge switch is a switch that connects directly to the end devices requiring network connectivity, most commonly servers and storage arrays in the data center. A switch that is 1 or 2 RU in height that acts as the access switch for devices within a rack is commonly called a Top of Rack switch.

The B24X is ideal for deployment as an all-purpose Top of Rack switch in demanding network environments due to its high-performance, resilient hardware characteristics and comprehensive network features support. The B24X can also be used to support NAS or iSCSI SAN storage in a shared or dedicated network environment (Figure 6).

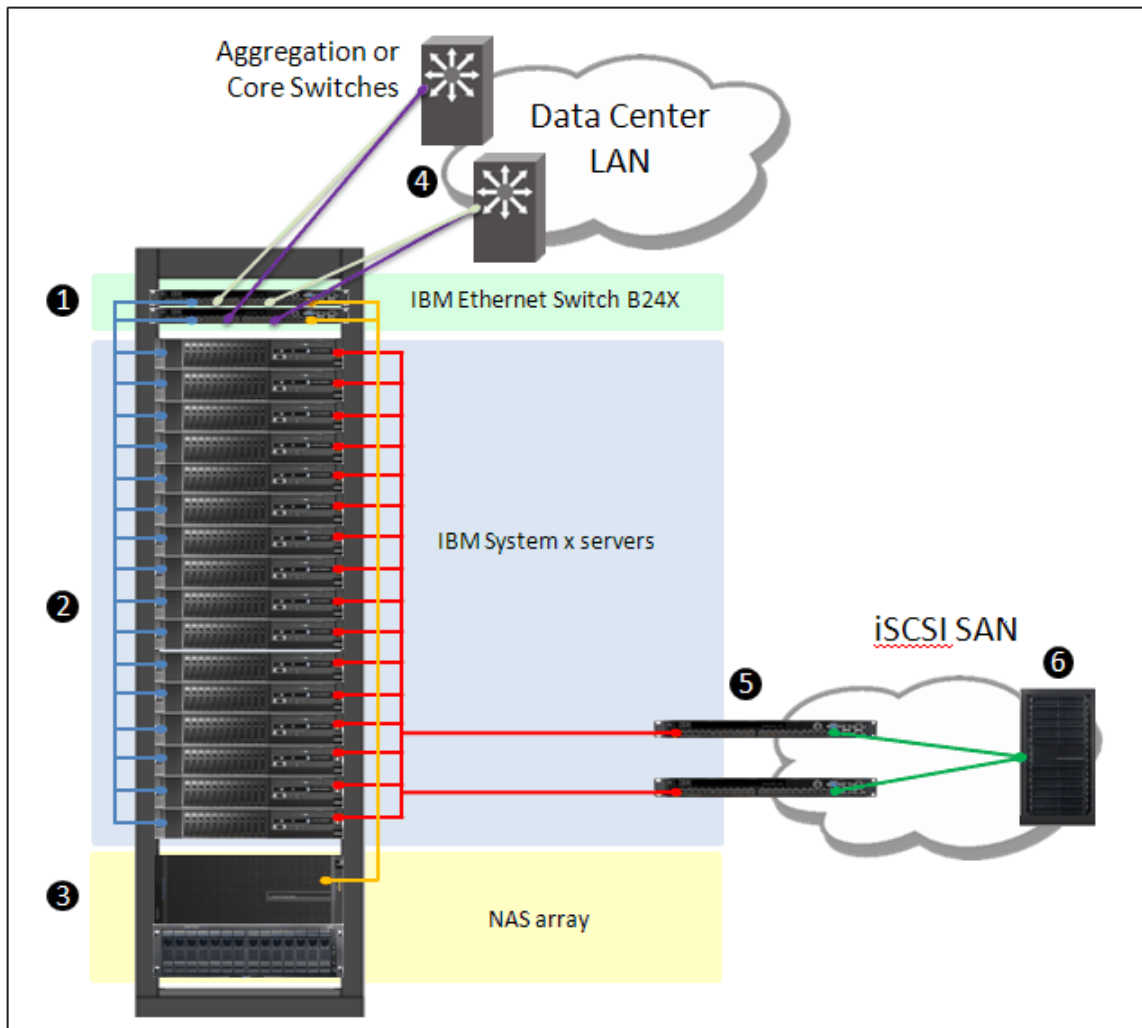

Figure 6. IBM Ethernet Switch B24X as Top of Rack switch with server and storage connections

Table 8 outlines the components used in Figure 6.

Table 8. Components used in reference to Figure 6

Diagram reference	Part number/ machine type	Description	Quantity
1	0563-012	IBM Ethernet Switch B24X	2
2	Varies	IBM System x server with 10 GbE NIC/CNAs <ul style="list-style-type: none"> See Table 5 for additional details. Other vendor servers can be used. 	16
3	Varies	NAS array	Varies
4	Varies	Existing network infrastructure, which can include IBM Systems Networking devices and other standards-compliant Ethernet/IP switches and routers	-
5	0563-012	IBM Ethernet Switch B24X	2
6	Varies	iSCSI SAN array	Varies

Solution details are:

- Forty-one rack units (with two RU servers)
- 1:1 subscription ratio within rack
- 2.43:1 over-subscription ratio to rest of network
- Connectivity to NAS or iSCSI SAN (or both) for mid-range scalable storage

In the solution shown in Figure 6 we have two IBM Ethernet Switch B24Xs providing connectivity to all devices within a single rack. Within the rack we have a mix of servers with 10 GbE connections to each B24X for redundancy. The B24X can also be used to connect to NAS arrays for scale-out file sharing and also to a separate iSCSI SAN for dedicated storage access as bandwidth and security needs require.

Network device connections

Figure 7 shows an example of the types of options that can be used to connect separate devices to the IBM Ethernet Switch B24X

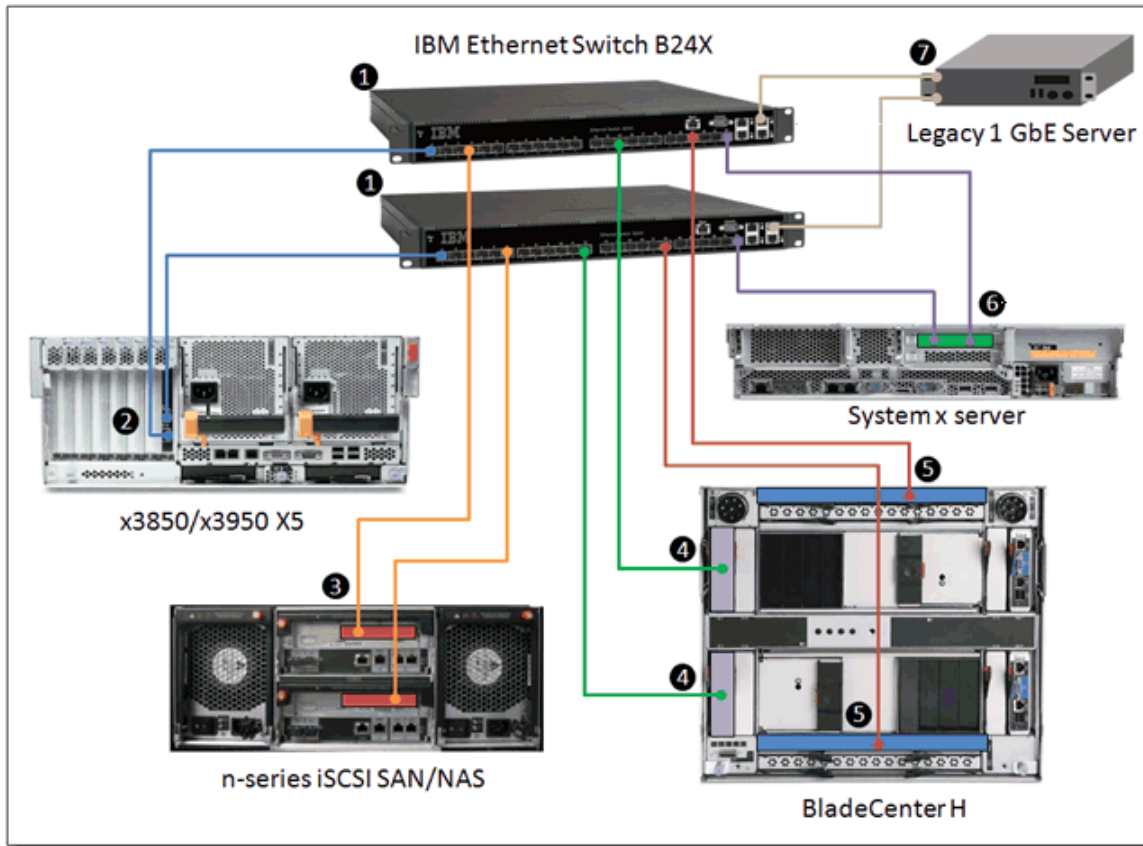

Figure 7. IBM Ethernet Switch B24X device connections

Table 9 outlines the components used in Figure 7.

Table 9. Components used in reference to Figure 7

Diagram reference	Part number/ machine type	Description	Quantity
1	0563-012	IBM Ethernet Switch B24X	2
2	Varies	IBM x3850/x3960 X5 (except ARx model) <ul style="list-style-type: none"> Comes with 2-port 10 GbE (SFP+) Emulex Virtual Fabric Adapter. Use a single Direct Attach cable (TwinAx) to connect to B24X, available in 1, 3, or 5 meters. (See Table 4.) 	-
3	Varies	NAS or iSCSI storage array	Varies
4	41Y8522	Cisco Catalyst 3110X Ethernet Switch Module <ul style="list-style-type: none"> On 3110X, use X2-10GB-SR= (10GBASE-SR X2 module). On B24X, use 69Y0389 (10GBASE-SR SFP+). Connect over multi-mode fiber. (Note: The X2 module has a SC connector, whereas the SFP+ has a LC connector.) 	2
5	46C7191	BNT Virtual Fabric 10Gb Ethernet Switch Module <ul style="list-style-type: none"> On BNT ESM, use 44W4408 (10GBASE-SR SFP+). On B24X, use 69Y0389 (10GBASE-SR SFP+). Connect over multi-mode fiber. 	2
6	Varies	IBM System x server <ul style="list-style-type: none"> On System x server with Brocade 10Gb CNA [42C1820], QLogic 10Gb CNA [42C1800], or Emulex Virtual Fabric Adapter [49Y4250], connect using a single Direct Attach cable (TwinAx), available in 1, 3, or 5 meters. (See Table 4.) On System x server with NetXtreme II 10 GigE Express Fiber SR Adapter (42C1790), use 69Y0389 (10GBASE-SR SFP+) on B24X and connect over multi-mode fiber. See Table 6 for server adapter details. 	-
7	Varies	Other servers <ul style="list-style-type: none"> If 10GBASE-SR, connect to B24X using 69Y0389 (10GBASE-SR SFP+) over multi-mode fiber. If 1 GbE, most 1 GbE NICs are RJ-45. Connect to one of the B24X's four RJ-45 ports over CAT5 cable. 	-

Interoperating in existing network environments

The IBM Ethernet Switch B24X interoperates seamlessly in existing network environments utilizing standards-based protocols. IBM Ethernet Switch B24X leverages the proven IronWare Operating System with an industry-standard CLI so network administrators can utilize their existing skill sets.

Figure 8 shows an example of the B24X used as an access and aggregation switch.

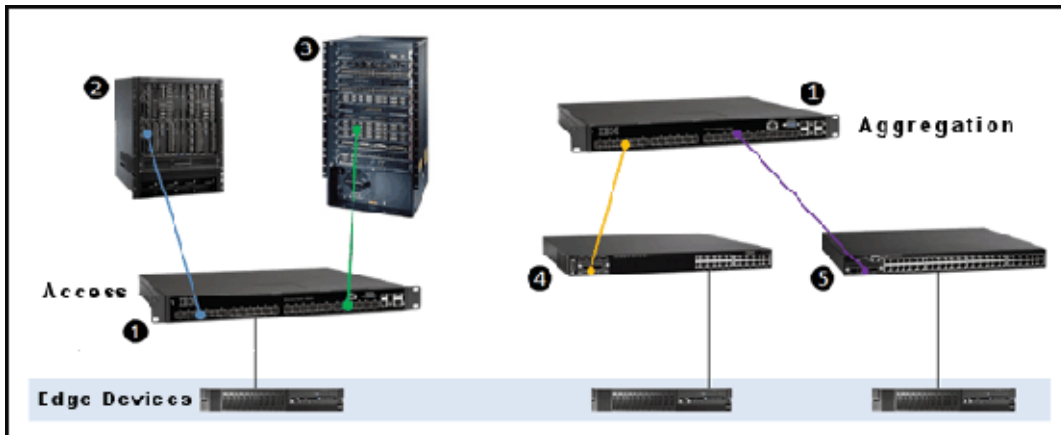

Figure 8. IBM Ethernet Switch B24X connecting to the network infrastructure

Table 10 outlines the components used in Figure 8.

Table 10. The components used in Figure 8

Diagram Reference	Part number/ machine type	Description	Quantity
1	0563-012	IBM Ethernet Switch B24X	1
2	4003-M16	IBM Ethernet Switch B16M <ul style="list-style-type: none"> On B16M, use FC1711 (4-port 10 GbE XFP module) and FC2110 (10GBASE-SR XFP). On B24X, use 69Y0389 (10GBASE-SR SFP+). Connect over multi-mode fiber. 	1
3	N/A	Cisco Catalyst 6509-E <ul style="list-style-type: none"> On 6509, use 8-port 10 GbE Fiber module with X2-10GB-SR (10GBASE-SR X2 module). Connect over multi-mode fiber. (Note: The X2 module has a SC connector, whereas the SFP+ has a LC connector.) 	1
4	0563-HCF	IBM Ethernet Switch B48Y (Data Center model) <ul style="list-style-type: none"> On B48Y, use 81Y1455 (4-port 10 GbE SFP+ module). Use a single Direct Attach cable (TwinAx) to connect to B24X, available in 1, 3, or 5 meters if length permits. Otherwise, on B24X use 69Y0389 (10GBASE-SR SFP+) and connect over multi-mode fiber. 	1
5	N/A	Cisco Catalyst Nexus 4948-10GE <ul style="list-style-type: none"> On the Catalyst use the 10GBASE-SR X2 module. On B24X, use 69Y0389 (10GBASE-SR SFP+). Connect over multi-mode fiber 	1

Power supplies and fans

The IBM Ethernet Switch B24X comes with one 300 W AC power supply and supports a second power supply for 1+1 redundancy. The power supplies are hot-swappable, auto-sensing, auto-switching, and load sharing, with a universal input (90 VAC to 264 VAC). The power supply has an IEC-C14 inlet that connects to a C13 power connector. Power cords are not included with the switch and must be provided separately.

The IBM Ethernet Switch B24X also comes with a single fan tray consisting of three variable-speed fans. If one fan within the fan tray fails it does not affect the operation of the other fans in the unit. The fan tray is hot-swappable, increasing device availability and serviceability.

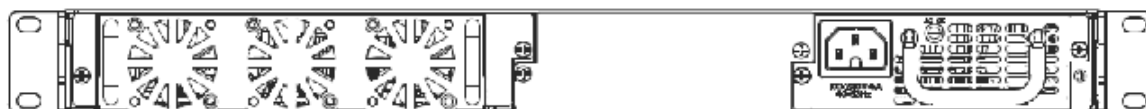

Figure 9. IBM Ethernet Switch B24X rear view (fans and power supply)

The airflow of the switch is primarily port/side (front) to non-port (back) side. Air is drawn into the system from vents on the front and front sides of the switch and expelled out the rear. The cooling characteristics of the system allow it to be deployed in server racks featuring hot-cold aisle containment without the need of special baffling.

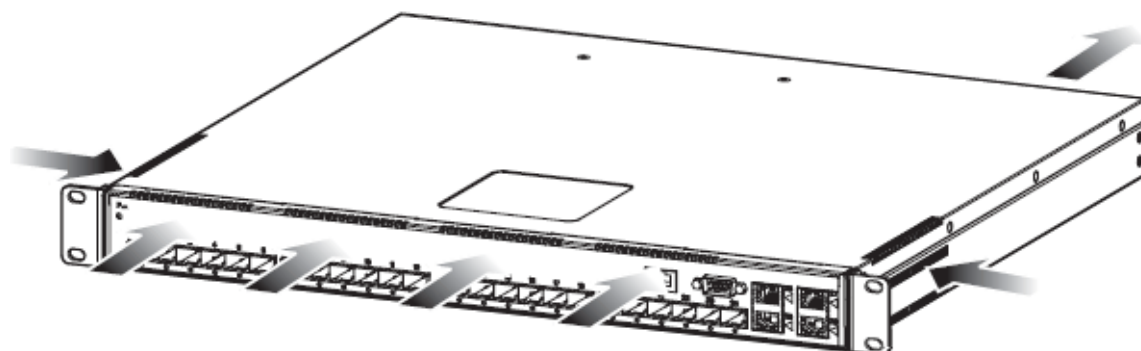

Figure 10. IBM Ethernet Switch B24X airflow

Installation

The IBM Ethernet Switch B24X comes with two rack-mount brackets affixed to each side for installation into an EIA-310D compliant rack. Screws for mounting the B24X to the rack are not included with the switch. Allow at least 3 inches of space at the front, back, and sides of the device for proper cabling and cooling

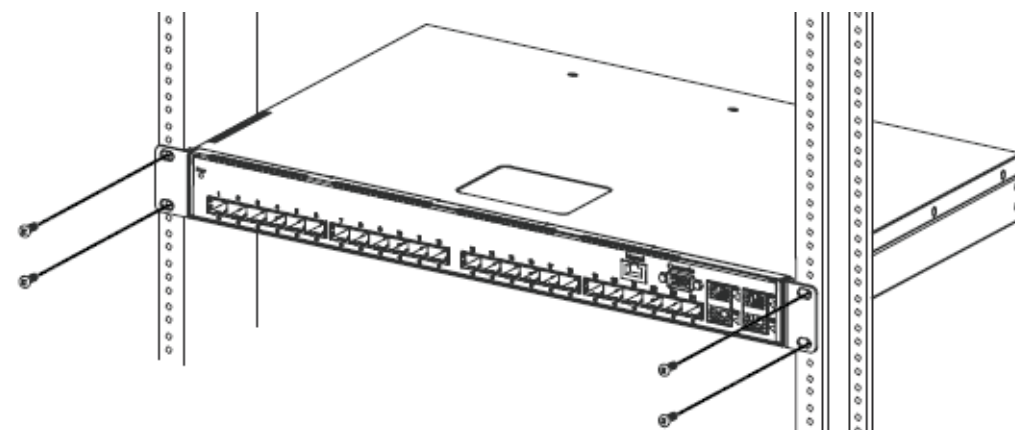

Figure 11. IBM Ethernet Switch B24X rack mount kit

Network cabling requirements

The network cables required for the IBM Ethernet Switch B24X are:

- 10GBASE-SR SFP+ transceiver [69Y0389]
 - 840 to 860 nm wavelength using multi-mode fiber cable, LC duplex connector. Operating distance supported depends on the multi-mode fiber cable used. See Table 11.
- 1000BASE-T (built-in 10/100/1000 MbE RJ-45 ports) and 1000BASE-TX SFP transceiver: up to 100 m over UTP Category 5e or higher cabling, RJ-45 connector.
- DB9 male serial console port: DB9 female-to-DB9 female straight-through serial console cable that comes with the switch.

Table 11. Multi-mode fiber cable distances supported

Multi-mode fiber cable	Distance	Loss
62.5 μ m (160 MHz*km)	26 m	1.6 dBm
62.5 μ m (200 MHz*km)	33 m	1.6 dBm
50 μ m (400 MHz*km)	66 m	1.7 dBm
50 μ m (500 MHz*km)	82 m	1.8 dBm
50 μ m (2000 MHz*km)	300 m	2.6 dBm

Related links

For more information, see the following resources:

- IBM System x network options support site for model-type 0563 - code download and documentation
http://www.ibm.com/support/entry/portal/Overview/Hardware/Systems/System_x/Network_Solutions/0563
- IBM Redbooks publication *IBM b-type Data Center Networking: Design and Best Practices Introduction*, SG24-7786
<http://www.redbooks.ibm.com/abstracts/sg247786.html?Open>
- IBM Redbooks publication *IBM b-type Data Center Networking: Product Introduction and Initial Setup*, SG24-7785
<http://www.redbooks.ibm.com/abstracts/sg247785.html?Open>
- IBM Ethernet Switch B48Y product page
<http://www-03.ibm.com/systems/x/hardware/networking/ethernetb48y/index.html>
- IBM Ethernet Switch B24X product page
<http://www-03.ibm.com/systems/x/hardware/networking/ethernetb24x/index.html>
- IBM Configuration and Options Guide
<http://www-03.ibm.com/systems/x/hardware/networking/ethernetb24x/index.html>
- IBM Smarter Networks
<http://www.smarternetworks.com>
- IBM b-type Ethernet switches and routers
<http://www-03.ibm.com/systems/networking/hardware/ethernet/b-type/index.html>

Notices

This information was developed for products and services offered in the U.S.A.

IBM may not offer the products, services, or features discussed in this document in other countries. Consult your local IBM representative for information on the products and services currently available in your area. Any reference to an IBM product, program, or service is not intended to state or imply that only that IBM product, program, or service may be used. Any functionally equivalent product, program, or service that does not infringe any IBM intellectual property right may be used instead. However, it is the user's responsibility to evaluate and verify the operation of any non-IBM product, program, or service. IBM may have patents or pending patent applications covering subject matter described in this document. The furnishing of this document does not give you any license to these patents. You can send license inquiries, in writing, to:

IBM Director of Licensing, IBM Corporation, North Castle Drive, Armonk, NY 10504-1785 U.S.A.

The following paragraph does not apply to the United Kingdom or any other country where such provisions are inconsistent with local law: INTERNATIONAL BUSINESS MACHINES CORPORATION PROVIDES THIS PUBLICATION "AS IS" WITHOUT WARRANTY OF ANY KIND, EITHER EXPRESS OR IMPLIED, INCLUDING, BUT NOT LIMITED TO, THE IMPLIED WARRANTIES OF NON-INFRINGEMENT, MERCHANTABILITY OR FITNESS FOR A PARTICULAR PURPOSE. Some states do not allow disclaimer of express or implied warranties in certain transactions, therefore, this statement may not apply to you. This information could include technical inaccuracies or typographical errors. Changes are periodically made to the information herein; these changes will be incorporated in new editions of the publication. IBM may make improvements and/or changes in the product(s) and/or the program(s) described in this publication at any time without notice.

Any references in this information to non-IBM Web sites are provided for convenience only and do not in any manner serve as an endorsement of those Web sites. The materials at those Web sites are not part of the materials for this IBM product and use of those Web sites is at your own risk. IBM may use or distribute any of the information you supply in any way it believes appropriate without incurring any obligation to you. Information concerning non-IBM products was obtained from the suppliers of those products, their published announcements or other publicly available sources. IBM has not tested those products and cannot confirm the accuracy of performance, compatibility or any other claims related to non-IBM products. Questions on the capabilities of non-IBM products should be addressed to the suppliers of those products. This information contains examples of data and reports used in daily business operations. To illustrate them as completely as possible, the examples include the names of individuals, companies, brands, and products. All of these names are fictitious and any similarity to the names and addresses used by an actual business enterprise is entirely coincidental.

Any performance data contained herein was determined in a controlled environment. Therefore, the results obtained in other operating environments may vary significantly. Some measurements may have been made on development-level systems and there is no guarantee that these measurements will be the same on generally available systems. Furthermore, some measurement may have been estimated through extrapolation. Actual results may vary. Users of this document should verify the applicable data for their specific environment.

COPYRIGHT LICENSE:

This information contains sample application programs in source language, which illustrate programming techniques on various operating platforms. You may copy, modify, and distribute these sample programs in any form without payment to IBM, for the purposes of developing, using, marketing or distributing application programs conforming to the application programming interface for the operating platform for which the sample programs are written. These examples have not been thoroughly tested under all conditions. IBM, therefore, cannot guarantee or imply reliability, serviceability, or function of these programs.

© Copyright International Business Machines Corporation 2010. All rights reserved.

Note to U.S. Government Users Restricted Rights -- Use, duplication or disclosure restricted by GSA ADP Schedule Contract with IBM Corp.

This document was created or updated on November 9, 2010.

Send us your comments in one of the following ways:

- Use the online **Contact us** review form found at:
ibm.com/redbooks
- Send your comments in an e-mail to:
redbook@us.ibm.com
- Mail your comments to:
IBM Corporation, International Technical Support Organization
Dept. HYTD Mail Station P099
2455 South Road
Poughkeepsie, NY 12601-5400 U.S.A.

This document is available online at <http://www.ibm.com/redbooks/abstracts/tips0785.html> .

Trademarks

IBM, the IBM logo, and ibm.com are trademarks or registered trademarks of International Business Machines Corporation in the United States, other countries, or both. These and other IBM trademarked terms are marked on their first occurrence in this information with the appropriate symbol (® or ™), indicating US registered or common law trademarks owned by IBM at the time this information was published. Such trademarks may also be registered or common law trademarks in other countries. A current list of IBM trademarks is available on the Web at <http://www.ibm.com/legal/copytrade.shtml>

The following terms are trademarks of the International Business Machines Corporation in the United States, other countries, or both:

BladeCenter®
IBM®
MVS™
Redbooks®
Redpaper™
Redbooks (logo)®
System i®
System p®
System Storage®
System x®

The following terms are trademarks of other companies:

Microsoft, and the Windows logo are trademarks of Microsoft Corporation in the United States, other countries, or both.

UNIX is a registered trademark of The Open Group in the United States and other countries.

Linux is a trademark of Linus Torvalds in the United States, other countries, or both.
Other company, product, or service names may be trademarks or service marks of others.