

IBM Network Printer 17



User's Guide

IBM Network Printer 17



User's Guide

Note!

Before using this information and the product it supports, be sure to read the general information under "Notices" on page xi.

Fourth Edition (January 1997)

This version obsoletes S544-5370-02.

The following paragraph does not apply to any other country where such provisions are inconsistent with local law.

INTERNATIONAL BUSINESS MACHINES CORPORATION PROVIDES THIS PUBLICATION "AS IS" WITHOUT WARRANTY OF ANY KIND, EITHER EXPRESS OR IMPLIED, INCLUDING, BUT NOT LIMITED TO THE IMPLIED WARRANTIES OF MERCHANTABILITY OR FITNESS FOR A PARTICULAR PURPOSE. Some states do not allow disclaimer of express or implied warranties in certain transactions, therefore, this statement may not apply to you.

Changes are made periodically to this publication.

Requests for IBM publications should be made to your IBM representative or to the IBM branch office serving your locality. If you request publications from the address given below, your order will be delayed, because publications are not stocked there.

A Reader's Comment Form is provided at the back of this publication. You may also send comments by fax to 1-800-524-1519, by e-mail to print_pubs@vnet.ibm.com, or by regular mail to:

Department H7FE Building 003G
IBM Printing Systems Company
Information Development
PO Box 1900
Boulder CO USA 80301-9191

IBM may use or distribute whatever information you supply in any way it believes appropriate without incurring any obligation to you.

© **Copyright International Business Machines Corporation 1996, 1997. All rights reserved.**

Note to U.S. Government Users — Documentation related to restricted rights — Use, duplication or disclosure is subject to restrictions set forth in GSA ADP Schedule Contract with IBM Corp.

Contents

Statement of Limited Warranty	vii
Production Status	vii
The IBM Warranty	vii
Warranty Service	viii
Extent of Warranty	viii
Limitation of Warranty	ix
Notices	xi
Trademarks	xi
Energy Star	xii
Communications Statements	xii
Federal Communication Notices Commission (FCC) Statement	xii
European Union (EU) Electromagnetic Conformity Statement	xiii
German Conformity Statement	xiii
Industry Canada Compliance Statement	xiii
The United Kingdom Telecommunications Act 1984	xiii
Japanese VCCI Class 2 ITE Statement	xiv
Safety Notices	xiv
Safety Precautions	xiv
Electrical Safety	xiv
Laser Safety	xv
About This Book	xvii
Conventions Used	xvii
Related Publications	xvii
Chapter 1. About Your Printer	1
Standard Features	1
Optional Features	2
Printer Drivers	2
Technical Support	3
Ordering Supplies	3
Memory Requirements	3
Using Network Printer Manager Utility	5
Obtaining Network Printer Manager Utility	5
Using Network Printer Resource Utility	5
Obtaining Network Printer Resource Utility	5
Obtaining Adobe Acrobat Portable Data Files	6
Chapter 2. Using the Operator Panel	7
Understanding the Operator Panel Indicator Lights	8
Common Messages	9
Using the Operator Panel Keys	10
Navigating Menus	12
Printing the Printer Configuration Page	13

Other Operator Panel Tasks	16
Making Duplex or Simplex Printing the Printer Default	16
Canceling a Print Job	16
Printing a Stored Page (PCL5e Jobs Only)	16
Printing a List of PCL5e Fonts	17
Printing a List of PostScript Fonts	17
Printing a List of IPDS Resident Fonts	17
Adjusting Print Density (Printing Darker or Lighter)	18
Changing the Power Savings (Sleep Mode) Interval	18
Changing the Language Shown on the Display Panel	19
Chapter 3. Paper Handling	21
Selecting Paper and Other Printable Material	22
Loading Paper and Envelopes into the Printer	24
Loading Letterhead and Prepunched Paper	24
Loading Paper into the 250-Sheet Main Paper Tray (Tray 1)	25
Loading Paper into the 100-Sheet Auxiliary Tray	29
Loading Envelopes into the 100-Sheet Auxiliary Tray	32
Loading Paper into the 500-Sheet Paper Trays (Tray 2, Tray 3)	36
Loading Envelopes into the Envelope Feeder	40
Using the Mailbox	44
Removing Prints From a Bin	44
Enabling Mailbox Bin Passwords	47
Disabling Mailbox Bin Passwords	49
Changing Mailbox Bin Passwords	51
Using the Paper Menu	53
Selecting The Default Input Tray	53
Selecting The Default Output Bin	53
Defining the Auxiliary Tray Paper Size	54
Defining the Envelope Feeder Envelope Size	54
Turning Tray Switching On or Off	55
Making Duplex or Simplex Printing the Printer Default	55
Chapter 4. Clearing Paper Jams	57
20 PAPER JAM: Paper Exit Area	58
21 PAPER JAM: Paper Tray Area	60
22 PAPER JAM: Duplex Unit Area	63
23 PAPER JAM: Toner Cartridge Area	68
24 PAPER JAM: Offset Paper Output Bin	70
25 PAPER JAM: Mailbox	71
Chapter 5. Operator Panel Menus	73
Test Menu	75
Paper Menu	77
Mailbox Menu	80
Configuration (Config) Menu	81
Memory Configuration (Memconfig) Menu	83
Parallel Menu	84

PCL Menu	85
PS Menu	88
Token Ring Menu	89
Ethernet Menu	91
Coax SCS Menu	93
Twinax SCS Menu	96
Coax Setup Menu	98
Twinax Setup Menu	100
Coax DSC/DSE Menu	102
IPDS Menu	104
Machine Information Menu	109
Language Menu	110
Chapter 6. Maintaining the Printer	111
Replacing Supplies	111
Changing the Toner Cartridge	111
Changing the Usage Kit	117
Removing the Used Fuser Unit	117
Installing a New Fuser Unit	120
Replacing the Transfer Roller	120
Removing the Used Transfer Roller	121
Installing a New Transfer Roller	124
Cleaning the Printer	125
Chapter 7. Installing Printer Options	127
Handling Static Sensitive Devices	127
The SIMM and Hard Drive Options	128
Removing the Controller Card	129
Installing a SIMM	130
Installing a Hard Drive	132
Reinstalling the Controller Card	134
The Network Interface Card	135
Installing a Network Interface Card	136
The Duplex Unit Option	140
Installing the Duplex Unit	140
Removing the Duplex Unit	142
The 500-Sheet Paper Tray Option (Tray 2, Tray 3)	144
Preparing the Printer	145
Stacking Two 500-Sheet Paper Trays	147
Placing the Printer on the Paper Tray Support Unit	151
Removing the 500-Sheet Paper Tray Support Units	156
Uncoupling Two 500-Sheet Paper Tray Support Units	159
The 500-Sheet Offset Paper Output Bin Option	161
Installing the 500-Sheet Offset Paper Output Bin	161
Removing the Offset Paper Output Bin	165
The 10-Bin Mailbox Option	167
Installing the 10-Bin Mailbox	167
Removing the Mailbox	172

The Envelope Feeder Option	174
Installing the Envelope Feeder	174
Removing the Envelope Feeder	177
Chapter 8. Configuring Printer Network Addresses	179
Setting IP, Subnet Mask, and Gateway Addresses	180
Setting the Locally Administered MAC Address (LAA)	181
Appendix A. Troubleshooting	183
Appendix B. Printer Messages	191
Status Messages	191
Error Messages	196
Appendix C. Specifications and Repackaging	203
Printer Specifications	203
Cartridge Specifications	204
Repackaging the Printer	205
Repair Inventory Worksheet	211
Customer Information	211
Inventory Checklist	211
Appendix D. Print Quality Problems	213
Print Is Too Light	213
Toner Spots on the Print	213
Repetitive Marks on the Print	214
Random Deletions or Light Areas on the Print	214
Vertical Marks on the Print	215
Vertical Bands of Deletions or Light Areas on the Print	215
Entire Print is Black	216
Entire Print Is Blank	216
White Spots Within Black Image Area	217
Printed Image Rubs Off or Smears	217
The Print Is Damaged	218
The Printed Image Is Blurred	218
Glossary	219
Index	225

Statement of Limited Warranty

The warranties provided by IBM* in this Statement of Limited Warranty apply only to Machines you originally purchase for your use, and not for resale, from IBM or an IBM authorized re-seller. The term "Machine" means an IBM machine, its features, conversions, upgrades, elements, or accessories, or any combination of them. Machines are subject to these terms only if purchased in the United States or Puerto Rico, or Canada, and located in the country of purchase. If you have any questions, contact IBM or your re-seller.

Machine: Network Printer 17
Warranty Period*: 12 months
* Contact your place of purchase for warranty service information.

Production Status

Each Machine is manufactured from new parts, or new and serviceable used parts (which perform like new parts). In some cases, the Machine may not be new and may have been previously installed. Regardless of the Machine's production status, IBM's warranty terms apply.

The IBM Warranty

IBM warrants that each Machine 1) is free from defects in materials and workmanship and 2) conforms to IBM's Official Published Specifications. IBM calculates the expiration of the warranty period from the Machine's Date of Installation. The date on your receipt is the Date of Installation, unless IBM or your re-seller informs you otherwise.

During the warranty period, IBM or your re-seller will provide warranty service under the type of service designated for the Machine and will manage and install engineering changes that apply to the Machine. IBM or your re-seller will specify the type of service.

For a feature, conversion, or upgrade, IBM or your re-seller may require that the Machine on which it is installed be 1) the designated, serial-numbered Machine and 2) at an engineering-change level compatible with the feature, conversion, or upgrade. Some of these transactions (called "Net-Priced" transactions) may include additional parts and associated replacement parts that are provided on an exchange basis. All removed parts become the property of IBM and must be returned to IBM.

Replacement parts assume the remaining warranty of the parts they replace.

If a Machine does not function as warranted during the warranty period, IBM or your re-seller will repair or replace it without charge. If IBM or your re-seller is unable to do so, you may return it to your place of purchase and your money will be refunded.

If you transfer a Machine to another user, warranty service is available to that user for the remainder of the warranty period. You should give your proof of purchase and this Statement to that user.

Warranty Service

To obtain warranty service for the Machine, you should contact your re-seller or call IBM. In the United States or Canada, call your point of purchase or IBM customer technical support at 1-800-358-6661 from 8:00 a.m. to 8:00 p.m, Eastern Standard Time. You may be required to present proof of purchase.

Depending on the Machine, the service may be 1) mail-in repair at IBM's Depot location (called Depot Mail-in Repair), 2) a "Repair" service at your location (called "On-site"), 3) a "Repair" service at one of IBM's or a re-seller's service locations (called "Carry-in"), or 4) "Exchange" service, either On-site or Carry-in.

When a type of service involves the exchange of a Machine or part, the item IBM or your re-seller replaces becomes its property and the replacement becomes yours. The replacement may not be new, but will be in good working order.

It is your responsibility to:

1. Obtain authorization from the owner (for example, your lessor) to have IBM or your re-seller service a Machine that you do not own;
2. Where applicable, before service is provided:
 - a. Follow the problem determination, problem analysis, and service request procedures that IBM or your re-seller provide,
 - b. Secure all programs, data, and funds contained in a Machine,
 - c. Inform IBM or your re-seller of changes in a Machine's location, and
 - d. For a Machine with exchange service, remove all features, parts, options, alterations, and attachments not under warranty service. Also, the Machine must be free of any legal obligations or restrictions that prevent its exchange; and
3. If the machine is not shipped in an IBM box, be responsible for loss of, or damage to, a Machine in transit when you are responsible for the transportation charges.
4. Be responsible for any damage resulting from improper packing of a Machine sent to IBM for "Depot Mail-in Repair" or "Exchange."

Extent of Warranty

IBM does not warrant uninterrupted or error-free operation of a Machine.

Misuse, accident, modification, unsuitable physical or operating environment, improper maintenance by you, or failure caused by a product for which IBM is not responsible may void the warranties.

THESE WARRANTIES REPLACE ALL OTHER WARRANTIES, EXPRESS OR IMPLIED, INCLUDING, BUT NOT LIMITED TO, THE IMPLIED WARRANTIES OF MERCHANTABILITY AND FITNESS FOR A PARTICULAR PURPOSE. HOWEVER, SOME LAWS DO NOT ALLOW THE EXCLUSION OF IMPLIED WARRANTIES. IF THESE LAWS APPLY, THEN ALL EXPRESS AND IMPLIED WARRANTIES ARE LIMITED IN DURATION TO THE WARRANTY PERIOD. NO WARRANTIES APPLY AFTER THAT PERIOD.

In Canada, warranties include both warranties and conditions.

Some jurisdictions do not allow limitations on how long an implied warranty lasts, so the above limitation may not apply to you.

Limitation of Warranty

Circumstances may arise where, because of a default on IBM's part (including fundamental breach) or other liability (including negligence and misrepresentation), you are entitled to recover damages from IBM. In each such instance, regardless of the basis on which you are entitled to claim damages, IBM is liable only for:

1. bodily injury (including death), and damage to real property and tangible personal property; and
2. the amount of any other actual loss or damage, up to the greater of \$100,000 or the charge for the Machine that is the subject of the claim.

Under no circumstances is IBM liable for any of the following:

1. third-party claims against you for losses or damages (other than those under the first item listed above);
2. loss of, or damage to, your records or data; or
3. economic consequential damages (including lost profits or savings) or incidental damages, even if IBM is informed of their possibility.

Some jurisdictions do not allow the exclusion or limitation of incidental or consequential damages, so the above limitation or exclusion may not apply to you.

This warranty gives you specific legal rights and you may also have other rights which vary from jurisdiction to jurisdiction.

Notices

References in this publication to IBM products, programs or services do not imply that IBM intends to make these available in all countries in which IBM operates. Any reference to an IBM licensed product, program, or service is not intended to state or imply that only IBM's product, program, or service may be used. Any functionally equivalent product, program, or service that does not infringe any of IBM's intellectual property rights may be used instead of the IBM product. Evaluation and verification of operation in conjunction with other products, except those expressly designated by IBM, is the user's responsibility.

Any performance data contained in this document was obtained in a controlled environment based on the use of specific data. The results that may be obtained in other operating environments may vary significantly. Users of this document should verify the applicable data in their specific environment. Therefore, such data does not constitute a performance guarantee or warranty.

IBM may have patents or pending patent applications covering subject matter in this document. The furnishing of this document does not give you any license to these patents. You can send license inquiries, in writing, to the IBM Corporation, IBM Director of Licensing, 506 Columbus Ave., Thornwood, N.Y. 10594 U.S.A.

Trademarks

The following terms are trademarks of the IBM Corporation in the United States or other countries or both:

AIX®	OS/400®
Application System/400®	Personal System/2®
AS/400®	Print Services Facility
IBM®	PS/2®
Intelligent Printer Data Stream	PSF
IPDS	WIN-OS/2
OS/2®	

The following terms are trademarks or registered trademarks of other companies:

Acrobat	Adobe Systems, Inc.
Macintosh	Apple Corporation
PostScript	Adobe Systems, Inc.
PCL5e	Hewlett Packard Co.
TonerMiser	DPTek
Windows	Microsoft Corp.

Energy Star



The Environmental Protection Agency (EPA) ENERGY STAR Computers program is a partnership effort with manufacturers of data processing equipment to promote the introduction of energy-efficient personal computers, monitors, printers, fax machines, and copiers to help reduce air pollution and global warming caused by electricity generation.

IBM Printing Systems Company participates in this program by introducing printers that reduce power consumption when they are not being used. As an Energy Star Partner, IBM Printing Systems Company, has determined that this product meets the Energy Star guidelines for energy efficiency.

Communications Statements

Federal Communication Notices Commission (FCC) Statement

IBM 4317-001

Note: This equipment has been tested and found to comply with the limits for a Class B digital device, pursuant to Part 15 of the FCC Rules. These limits are designed to provide reasonable protection against harmful interference in a residential installation. This equipment generates, uses, and can radiate radio frequency energy and, if not installed and used in accordance with the instructions, may cause harmful interference to radio communications. However, there is no guarantee that interference will not occur in a particular installation. If this equipment does cause harmful interference to radio or television reception, which can be determined by turning the equipment off and on, the user is encouraged to try to correct the interference by one or more of the following measures:

- Reorient or relocate the receiving antenna.
- Increase the separation between the equipment and receiver.
- Connect the equipment into an outlet on a circuit different from that to which the receiver is connected.
- Consult an IBM authorized dealer or service representative for help.

Properly shielded and grounded cables and connectors (IEEE 1284 compliant) must be used in order to meet FCC emission limits. Proper cables and connectors are available

from IBM authorized dealers. IBM is not responsible for any radio or television interference caused by using other than recommended cables and connectors or by unauthorized changes or modifications to this equipment. Unauthorized changes or modifications could void the user's authority to operate the equipment.

This device complies with Part 15 of the FCC Rules. Operation is subject to the following two conditions: (1) this device may not cause harmful interference, and (2) this device must accept any interference received, including interference that may cause undesired operation.

Responsible Party:

International Business Machines, Corp.
Old Orchard Road
Armonk, NY 10504
Tele: 1-800-772-2227

European Union (EU) Electromagnetic Conformity Statement

This product is in conformity with the protection requirements of EU Council Directive 89/336/EEC on the approximation of the laws of the Member States relating to electromagnetic compatibility. IBM cannot accept responsibility for any failure to satisfy the protection requirements resulting from a non-recommended modification of the product, including the fitting of non-IBM option cards.

EU Conformity Statement: This product has been tested and found to comply with the limits for Class B Information Technology Equipment according to CISPR 22/European standard EN 55022. The limits for Class B equipment were derived for typical environments to provide reasonable protection against interference with licensed communication devices.

German Conformity Statement

Dieses Gerät erfüllt die Bedingungen der EN 55022 Klasse B.

Industry Canada Compliance Statement

This Class B digital apparatus meets the requirements of the Canadian Interference-causing equipment regulations.

Cet appareil numérique de la classe B respecte toutes les exigences du Règlement sur le matériel brouiller du Canada.

The United Kingdom Telecommunications Act 1984

This apparatus is approved under the approval No. NS/G/1234/J/100003 for the indirect connections to the public telecommunications systems in the United Kingdom.

Japanese VCCI Class 2 ITE Statement

この装置は、第二種情報処理装置（住宅地域又はその隣接した地域において使用されるべき情報処理装置）で住宅地域での電波障害防止を目的とした情報処理装置等電波障害防止技術協議会（VCCI）基準に適合しております。

しかし、本装置をラジオ、テレビジョン受信機に近接してご使用になると、受信障害の原因となることがあります。

取扱説明書に従って正しい取り扱いをして下さい。

vccib

Safety Notices

There are three levels of safety notices:

DANGER calls attention to a situation that is potentially or extremely hazardous to people.

CAUTION calls attention to a situation that is potentially hazardous to people.

Attention calls attention to the possibility of damage to a program, device, system, or data. Attention notices are located throughout this publication, but are not listed here.

Safety Precautions

Electrical Safety

This printer is inspected and listed by recognized national testing laboratories, such as Underwriters Laboratories, Inc. (UL) in the U.S.A. and Canadian Standards Association (CSA) in Canada. Listing of a product by a national testing laboratory indicates that the product is designed and manufactured in accordance with national requirements intended to minimize safety hazards. IBM equipment meets a very high standard of safety in design and manufacture. Remember, however, that this product operates under conditions of high electrical potentials and heat generation, both of which are functionally necessary.

Because the paper and toner used in the printer can burn, you should take normal precautions to prevent fire. These precautions include common-sense measures, such as keeping potentially combustible materials (for example, curtains and chemicals) away from the printer, providing adequate ventilation and cooling, limiting unattended operation, and having trained personnel available and assigned to the printer.

Laser Safety

This printer complies with the performance standards set by the U.S. Food and Drug Administration for a Class 1 Laser Product. This means that the printer belongs to a class of laser products that does not produce hazardous laser radiation in a customer accessible area. This classification was accomplished by providing the necessary protective housing and scanning safeguards to ensure that laser radiation is inaccessible or within Class 1 limits.

There are various tool-operated machine covers that should be moved, removed, or replaced only by trained service personnel. There are no operator controls or adjustments associated with the laser.

No operator maintenance is required to keep the product in compliance as a Class 1 Laser Product. No adjustments that affect laser operation or power are accessible to the operator.

This printer is a Class 1 Laser Product that contains an enclosed Class 3B laser.

About This Book

This book is designed to help you use the Network Printer 17. It describes how to:

- Use the operator panel to navigate menus and control the printer
- Load and select paper and other print materials
- Clear paper jams
- Change printer supplies
- Install printer options
- Troubleshoot printer problems
- Interpret messages displayed on the operator panel

Conventions Used

Names of keys on the operator panel are shown in bold typeface. For example:

- Press the **Continue/Enter** key.
- Press **Page Eject**.

Related Publications

The following books contain information that relates to the Network Printer 17:

- *IBM Network Printer 17: Quick Setup*, G544-5346, describes how to set up the Network Printer 17
- *IBM Network Printers: Ethernet and Token Ring Configuration Guide*, G544-5240, describes how to configure the Ethernet and token-ring network interface cards (this book is included with the cards)
- *IBM Network Printers: Twinax/Coax Configuration Guide*, G544-5241, describes how to configure the twinax and coax network interface cards (this book is included with the cards)
- *IBM Network Printer 17: Safety Instructions*, G544-5347, contains safety notices in several languages
- *IBM Network Printers: PCL5e and PostScript Level 2 Technical Reference*, S544-5344, contains technical reference information about Network Printer 17 PostScript and PCL5e support
- *IBM Network Printers: IPDS and SCS Technical Reference*, S544-5312, contains technical reference information about Network Printer 17 IPDS and SCS support

Chapter 1. About Your Printer

The Network Printer 17 is a multifunctional, 17 page-per-minute laser printer. You can attach it directly to your workstation and, using optional network interface cards, you can attach it to networks and other computing environments. You can also add optional features, such as an envelope feeder and one or two 500-sheet paper trays.

The following illustration shows the Network Printer 17 with some of the optional features installed:

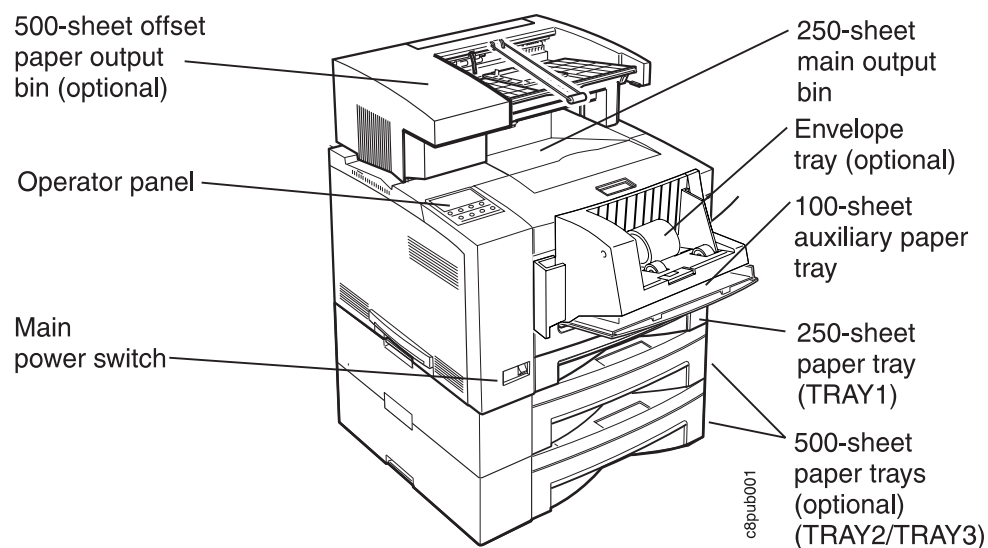

Standard Features

Standard features of the printer include:

- Printing speed of up to 17 pages per minute
- Resolution of 600 dots per inch (dpi)
- PCL5e support
- 4MB of memory
- Parallel interface (IEEE 1284)
- 250-sheet paper tray
- 100-sheet auxiliary tray
- 250-sheet paper output bin
- Printer drivers

Optional Features

Optional features include the following:

- Up to two additional 500-sheet paper trays
- 500-sheet offset paper output bin
- Duplex unit
- Envelope feeder with a capacity of 75 envelopes
- 10-bin mailbox
- 4MB, 8MB, 16MB, and 32MB memory SIMMs
- Adobe PostScript Level 2 SIMM
- IBM IPDS SIMM
- Flash Memory SIMM (2MB, 4MB)
- 810MB hard drive
- Attachment cards:
 - IBM Network Card for Ethernet (10Base2 or 10BaseT)
 - IBM Network Card for Token Ring
 - IBM Twinax SCS Interface
 - IBM Coax SCS/DSC/DSE Interface

Note: For information about installing optional features, see Chapter 7, “Installing Printer Options” on page 127. For information about printer memory and memory requirements, see “Memory Requirements” on page 3.

Printer Drivers

Before you can print from your PC or workstation to your printer, you need to install the right printer driver on your system. The Network Printer 17 includes diskettes which contain PCL5e printer drivers for the following systems:

- Windows 3.1, Windows 3.11, Windows for Workgroups 3.11, Win-OS/2
- Windows 95
- Windows NT 3.51, Windows NT 4.0
- OS/2 2.11, OS/2 Warp
- AIX 3.2.5, AIX 4.1

Notes:

1. For your printer driver to work effectively, you must indicate to your printer driver what features are installed on your printer, for example, what trays are installed, and how much memory is installed. Therefore, after you install a driver, make sure you update it to indicate the features installed on your printer. Also, if you install (or remove) a feature at a later date, make sure you update your printer driver.
2. Each operating system has unique driver installation procedures. For specific installation instructions, see the driver installation documentation for your operating system and the Readme file on the diskette that includes the driver of your choice.
3. Your printer may include additional drivers not included in this list.
4. PostScript drivers are shipped with the optional PostScript feature.
5. Updated printer drivers are also available as follows:

- a. Access the IBM Printing Systems Home Page at:
<http://www.can.ibm.com/ibmprinters>
- b. Select **Printer Drivers/Product Updates**.
- c. Use the menu selections to find the printer driver you want.

Technical Support

If you run into a problem, see Appendix A, “Troubleshooting” on page 183. If you still cannot solve the problem, IBM customer technical support is available at no additional charge during the warranty period. In the U.S.A. and Canada, call 1-800-358-6661.

Ordering Supplies

Printing supplies can be ordered through your IBM authorized printer or printer supplies reseller. If you have no reseller, you can call 1-888-IBM-PRINT (1-888-426-7746) in the U.S. or Canada to ask for an authorized dealer or to order from IBM Printer Supplies.

In other countries, contact your point of purchase for information about where to order supplies.

In Europe, you can call IBM Supplies Fulfillment Operations at 31-43-350 2756 or at the following numbers:

- Denmark: 80015534
- Finland: 08001-13110
- France: 05-905871
- Germany: 0130 818005
- Italy: 1-678 78349
- Norway: 800-11389
- Sweden: 020-794270
- United Kingdom: 0800-968679

Memory Requirements

Table 1 on page 4 shows the minimum memory requirements for Network Printer 17 based on various functional requirements.

Notes:

1. The PAGEPROT menu item is available on the PCL Menu, the PostScript (PS) Menu, and the IPDS Menu. It determines whether or not the printer uses compression when it prints complex pages.
 - PAGEPROT=AUTO—the printer uses compression when it runs into memory constraints. This can reduce print speed.
 - PAGEPROT=ON—the printer does not use compression and therefore requires more memory.

2. *Context Saving* allows the printer to remember information about the current data stream when it switches back and forth from one job type (PostScript or PCL5e) to another. (Network Printer 17 always does context saving for IPDS.) For PCL5e, this includes information about downloaded permanent fonts, macros, and user-defined patterns. For PostScript, this includes all of the information found in the PostScript VM allocation.

The Memory Configuration (MEMCONFIG) Menu provides two menu items, PCL SAVE and PS SAVE, which allow you to set context saving on or off for each data stream. These menu items are displayed only if there is enough memory in the printer to permit context saving. The PS SAVE menu item is displayed only if the PostScript SIMM is installed.

<i>Table 1. Memory Requirements</i>		
Requirement	Simplex	Duplex
Base configuration only		
PAGEPROT=AUTO	4MB	4MB
PAGEPROT=AUTO (legal-size paper)	4MB	8MB
PAGEPROT=ON (letter-size paper)	8MB	8MB
PAGEPROT=ON (legal-size paper)	8MB	12MB
Context Saving	12MB	16MB
Base configuration with PostScript		
PAGEPROT=AUTO	4MB	4MB
PAGEPROT=AUTO (legal-size paper)	4MB	8MB
PAGEPROT=ON (letter-size paper)	8MB	12MB
PAGEPROT=ON (legal-size paper)	8MB	12MB
Context Saving	12MB	16MB
Base configuration with IPDS		
PAGEPROT=AUTO	8MB	8MB
PAGEPROT=AUTO (legal-size paper)	8MB	8MB
PAGEPROT=ON (letter-size paper)	8MB	12MB
PAGEPROT=ON (legal-size paper)	12MB	16MB
Context Saving	12MB	16MB
Base configuration with IPDS and PostScript		
PAGEPROT=AUTO	8MB	12MB
PAGEPROT=AUTO (legal-size paper)	12MB	12MB
PAGEPROT=ON (letter-size paper)	12MB	16MB
PAGEPROT=ON (legal-size paper)	16MB	16MB
Context Saving	16MB	20MB

Using Network Printer Manager Utility

Network Printer Manager (NPM) Utility is a tool for network administrators. NPM can:

- Enable you to install and configure IBM Network Printers in Local Area Networks (LANs), including Novell 3.12 and 4.X networks in bindery emulation (printer network cards can be NDS-configured with NWAdmin).
- Monitor and provide network printer status information including online/offline status, paper jams, out of toner conditions, and empty tray conditions.

NPM uses industry standard, open systems System Network Management Protocol (SNMP). SNMP supports Management Information Base (MIB) which is a collection of information that describes the printer's functions and features.

The initial version of NPM supports IBM OS/2. Other versions will be made available on the World-wide Web through the IBM Printing Systems Company home page.

Obtaining Network Printer Manager Utility

To obtain the Network Printer Manager Utility, follow these steps:

1. Access the IBM Printing Systems Company Home Page at <http://www.can.ibm.com/ibmprinters>.
2. Select **Printer Drivers/Product Updates**.
3. Use the menu selections to find the Network Printer Manager Utility version or update you want.

Using Network Printer Resource Utility

The Network Printer Resource Utility (NPRU) is a utility that enables administrators to download fonts and overlays (PCL macros and PostScript overlays) to the printer. Using NPRU, the network administrator can select PCL Intellifonts, TrueType fonts, PostScript Type 1 fonts, and PCL or PostScript overlays on a workstation for download. These resources can be downloaded to memory (DRAM) on the printer, or to the flash or a hard drive, if these options are installed the printer.

The network administrator can provide a network address for the NPRU database of downloaded resources to workstation users. Those users can then use the printer driver to connect to the database, enabling them to select downloaded fonts and overlays from within their applications.

The NPRU is a separate program that uses the printer driver programs to perform the download function. For more information about using NPRU, refer to the README file that is supplied with the utility.

Obtaining Network Printer Resource Utility

The OS/2 NPRU is shipped with the Network Printer 17. To obtain other versions or updates, follow these steps:

1. Access the IBM Printing Systems Company Home Page at <http://www.can.ibm.com/ibmprinters>.
2. Select **Printer Drivers/Product Updates**.
3. Use the menu selections to find the NPRU version or update you want.

Obtaining Adobe Acrobat Portable Data Files

This manual is available in Adobe Acrobat Portable Data File (PDF) format for online viewing and printing. To obtain this manual in PDF format:

1. Access the IBM Printing Systems Company Home Page at <http://www.can.ibm.com/ibmprinters>.
2. Select **Printer Drivers/Product Updates**.
3. Use the menu selections to find the document you want.

Chapter 2. Using the Operator Panel

This chapter describes how to use the Network Printer 17 operator panel. The operator panel is located on the top, left-hand side of the printer. It consists of a message display area, status indicator lights, and operator keys.

Message display area - shows printer messages and setup menu information

Keys - cancel printing, navigate menus, take the printer offline or put it online

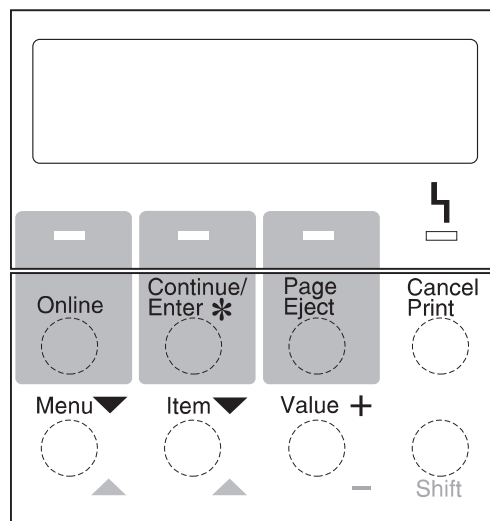

Indicators - show printer status (such as online or offline)

- For information about indicator lights, see “Understanding the Operator Panel Indicator Lights” on page 8.
- For information about the most common messages you will see in the message display area, see “Common Messages” on page 9. For a complete listing, see Appendix B, “Printer Messages” on page 191.
- For information about operator panel keys, see “Using the Operator Panel Keys” on page 10 and “Navigating Menus” on page 12.
- For an overview of some of the most common operator panel tasks, see “Other Operator Panel Tasks” on page 16.
- For a complete overview of all printer menus, see Chapter 5, “Operator Panel Menus” on page 73.

Understanding the Operator Panel Indicator Lights

The status indicators are located at the center of the operator panel.

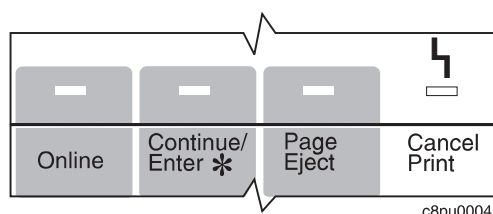

Indicator lights can be on, off, or blinking

Indicator	Condition
Online	<p>On—the printer is online and idle.</p> <p>Blinking—the printer is online and receiving or processing data.</p> <p>Off—the printer is offline. Note that the printer must be offline before you can change menu settings.</p>
Continue	<p>On—a condition that requires operator attention exists. Press the Continue/Enter key to continue printing or press the Cancel Print key to cancel printing. (If the Auto-continue function is on, the printer may automatically resume printing after thirty seconds. For more information, see the description of the AUTOCONTINU item under “Configuration (Config) Menu” on page 81.)</p> <p>Off—the printer is operating normally.</p>
Page Eject	<p>On—a page or partial page is stored in memory. If you are printing a PCL5e job, you can press the Page Eject key to print the page. The Page Eject key has no effect on PostScript or IPDS jobs.</p> <p>Blinking—the printer is printing the PCL5e page you pressed the Page Eject key to print. If you are running a continuous test (CONTINUOUS TEST from the Test Menu) and you press the Cancel Print key, the Page Eject indicator blinks to inform you that the printer is canceling the test.</p> <p>Off—no pages are stored in the printer memory.</p>
<p>Attention</p> 	<p>Blinking—the printer requires attention.</p> <p>Off—the printer is operating normally.</p>

Common Messages

The message display area is located at the top of the operator panel. The following table describes the most common display messages. For a list of all messages, see Appendix B, "Printer Messages" on page 191.

Message	Description/Response
READY	The printer is ready to receive a print job. Response: None required.
WARMING UP...	The printer is warming up. When it is ready to print, the message changes to READY. Response: None required.
I/O INITIALIZING	The network interface card is initializing. Response: None required.
OFFLINE	The printer is offline and cannot receive print jobs. Response: To receive printing jobs, press the Online key.
PCL PARALLEL	The printer is online and receiving data for a PCL5e print job through the parallel port. Response: None required.
PS PARALLEL	The printer is online and receiving data for a PostScript print job through the parallel port. Response: None required.
02 TONER LOW	The toner is either low or depleted. Response: Install a new toner cartridge. See "Changing the Toner Cartridge" on page 111.
LOAD <i>paper-size</i> IN tray	A tray is out of paper. Response: Load paper. See "Loading Paper and Envelopes into the Printer" on page 24.

Using the Operator Panel Keys

The operator panel keys enable you to configure and operate the printer. They are located at the bottom of the operator panel.



c8pu0006

Use the **Online** key to take the printer offline or to put it back online.

Note: The printer must be offline before you can change menu settings, cancel jobs, or use the Page Eject key.



c8pu0007

Use the **Continue/Enter** key to continue printing or to confirm a menu value.

Note: To change a menu item to a new value, you must press the **Continue/Enter** key when the value is displayed in the message display area. After you press **Continue/Enter**, an asterisk (*) appears next to the new value, indicating that it is active.

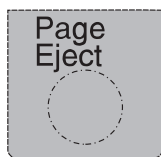

c8pu0008

Use the **Page Eject** key to print a PCL5e job that is stored in the memory buffer of the printer. (The Page Eject indicator light is on when a page is in the buffer.) The printer prints the page even if it is not complete in the memory buffer. The **Page Eject** key does not apply to PostScript or IPDS jobs.

Note: The printer must be offline before you can print the buffered page.

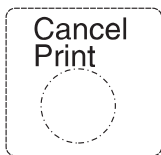

c8pu0009

Use the **Cancel Print** key to cancel the current print job. (After you print the **Cancel Print** key, it may take a while before the current job stops printing.) After the job is canceled, the printer begins printing the next job in the queue.

Note: The printer must be offline before you can cancel a job.

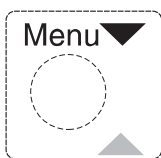

c8pu0010

Use the **Menu** key to scroll through the menu list. As you scroll through the list, the current menu is displayed in the message display area.

Note: The printer must be offline before you can navigate menus.



c8pu0011

Use the **Item** key to scroll through the list of items for the menu listed in the message display area. As you scroll through the list, the current item and, if applicable, the current value for the item is displayed in the message display area, just below the name of the current menu.

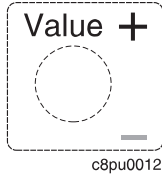

Use the **Value** key to scroll through a list of acceptable values for a menu item. Press the **Value** key once to scroll forward one value. Press and hold the **Value** key to scroll more quickly through the list (especially for numeric values).

Note: To select a new value, press the **Continue/Enter** key when the value is displayed in the message display area. An asterisk (*) appears next to the value, indicating that it is now active.

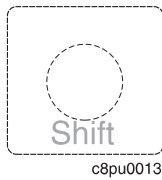

Use the **Shift** key to reverse the order in which you scroll when you use the **Menu**, **Item**, or **Value** keys.

Navigating Menus

There are two types of menus: action menus and configuration menus.

Action menus contain a list of actions you can perform, such as printing a list of active fonts or printing a printer configuration page. There are two action menus: the Test Menu and the Machine Info Menu.

To work with action menus:

1. Make sure the printer is offline. If the printer is online, press the **Online** key to take it offline.
2. Press the **Menu** key to display the menu you want.
3. Press the **Item** key to display the action item you want.
4. Press the **Continue/Enter** key to perform the action.

For an example of working with an action menu, see “Printing the Printer Configuration Page” on page 13.

Configuration menus contain lists of items that define current settings for the printer, such as default fonts, default input trays and output bins, and attachment configuration settings.

To work with configuration menus:

1. Make sure the printer is offline. If the printer is online, press the **Online** key to take it offline.
2. Press the **Menu** key to display the menu you want.
3. Press the **Item** key to display the item you want.
4. Press the **Value** key to display the value you want.
5. Press the **Continue/Enter** key to change the setting to the value currently displayed in the message display area. An asterisk (*) appears next to the value after it is selected.

Note: Once you select a new value, it stays selected until you change it or you reset the printer defaults. Menu settings are saved when you power off the printer.

Important!

Many print applications allow you to specify values such as fonts, input trays, and output bins. If you use your print application (or printer driver) to specify a value, that value will be used and the default value set at the printer will be ignored.

Printing the Printer Configuration Page

1. Make sure the printer is offline. If the printer is online, press the **Online** key to take it offline.



2. Press the **Menu** key once. TEST MENU appears in the message display area.



3. Press the **Item** key once. CONFIG PAGE appears in the message display area. Note that the menu name appears on the top line and the action item appears on the second line.



- Press the **Continue/Enter** key to print the configuration page. (It takes a moment or two.) The following figure shows a sample printer configuration page.

IBM Network Printer 17
Configuration Page

<p>TEST MENU ITEM CONFIG PAGE PRINT PS FONTS PRINT PCL FONTS PRINT PS DEMO CONTINUOUS TEST RESET PRINTER FACTORY DEFAULT ONLINE HEX PRINT</p> <p>PAPER MENU SOURCE=TRAY2 OUTPUT=MAIN TRAY SWITCH=ON MANUAL=OFF AUXSIZE=LETTER ENVSIZE=MONARCH DUPLEX=OFF BINDING=LONG TRAY RENUM=OFF</p> <p>CONFIG MENU ITEM JAMRECOVERY=OFF AUTOCONTINU=ON DENSITY=3 PWRSVAV=30 MIN QUALITY=NORMAL</p> <p>MEMCONFIG MENU ITEM PCL SAVE=OFF PS2 SAVE=OFF</p>	<p>PARALLEL MENU ITEM PERSONALTY=AUTO BI-DI=ON PORT TMEOUT=15</p> <p>PCL MENU ITEM PAGEPROT=AUTO COPIES=1 PAGESIZE=LETTER ORIENTATION=P EDGE-EDGE=OFF FORM=60 LINES FNTSRC=INTERNAL FONTNUM=0 PTSIZE=12.00 PITCH=10.00 SYMSET=ROMAN-8</p> <p>PS MENU ITEM PAGEPROT=AUTO COPIES=1 PRINT ERRS=OFF</p> <p>TOKEN RING MENU ITEM PERSONALTY=AUTO PORT TMEOUT=15 IP ADDRESS=9.99.999.999 SUBNET MASK=255.255.255.0 GATEWAY ADDRESS=9.999.999.998 MAC ADDRESS=00.00.93.00.C0.C6</p>	<p>MACHINE INFO MENU ITEM PAGE COUNT ERROR LOG TONER CTR FUSER CTR</p> <p>LANGUAGE MENU LANG=ENGLISH</p> <p>INSTALLED OPTIONS TRAY 2 DUPLEX PS TOKEN RING 8 MB Extra Memory TOTAL MEMORY=12MB</p> <p>AUTOSENSED PAPER TRAY 1=LETTER TRAY 2=LETTER</p> <p>PRINTER DETAILS PAGE COUNT=1039 TONER CTR=984 FUSER CTR=984 CODE LEVELS CTL 1.43 PCL 1.3.1 PS 1.18 TR 5.17</p>
--------------------------------------------------------------------------------------------------------------------------------------------------------------------------------------------------------------------------------------------------------------------------------------------------------------------------------------------------------------------------------------------------------------------------------------------------------------------------------------------------------------------------------------------------------------------------	------------------------------------------------------------------------------------------------------------------------------------------------------------------------------------------------------------------------------------------------------------------------------------------------------------------------------------------------------------------------------------------------------------------------------------------------------------------------------------------------------------------------------------------------------------------------------------------------------	------------------------------------------------------------------------------------------------------------------------------------------------------------------------------------------------------------------------------------------------------------------------------------------------------------------------------------------------------------------------------------------------------------------------------------------------------------------------------------------------

The configuration page lists:

- Menus**—All of the menu settings currently active for your printer. Note that the list of menus you see is determined by the options you have installed; for example, you see the Ethernet Menu only when you have the Ethernet attachment installed. Also note that the configuration page displays the menus and options in the order they appear on the operator panel; this allows you to use the configuration page as a menu map.

For a description of all available menus, see Chapter 5, “Operator Panel Menus” on page 73.

- Installed Options**—The options and memory you have installed.

Important: IBM recommends doing the following whenever you install a feature:

- Print the printer configuration page. Then look under Installed Options to make sure the printer recognizes the option and the installation was successful.
- Update your printer driver to indicate the new feature is available. (This includes features such as new trays and extra memory; you do not need to indicate new network cards.)

- **Autosensed Paper**—The paper loaded in various trays.
 - **Printer Details**—Page counts for the printer, the toner cartridge, and the fuser. Note that you should reset the toner and fuser counts whenever you change toner or the fuser. See “Machine Information Menu” on page 109 for more information.
5. To restore the printer to READY status, press the **Online** key.

Other Operator Panel Tasks

The rest of this chapter contains examples of how to perform some other common operator panel tasks. In addition, “Using the Paper Menu” on page 53 contains examples of how you can use the operator panel to change Paper Menu settings, such as default input trays and output bins, and default paper sizes. Chapter 8, “Configuring Printer Network Addresses” on page 179 describes how to set TCP/IP network values (IP address, gateway address, subnet mask, locally administered MAC address) from the operator panel.

Making Duplex or Simplex Printing the Printer Default

Situation: You want to make duplex printing or simplex printing the printer default.

Note: Values set in print jobs (either by the print application or by the printer driver) override values you set at the printer. If a print job specifies simplex printing and the printer default is duplex, the printer honors the print job setting and prints on one side only.

Action:

1. Press the **Online** key until you see OFFLINE in the display.
2. Press the **Menu** key until you see PAPER MENU in the display.
3. Press the **Item** key until you see DUPLEX=ON* or DUPLEX=OFF in the display.
4. Press the **Value** key until you see the new value you want.
5. Press the **Continue/Enter** key to select the new setting. An asterisk appears next to the value, showing that it is active.
6. To restore the printer to READY status, press the **Online** key.

Canceling a Print Job

Situation: You want to cancel the job that is currently printing.

Action:

1. Press the **Online** key to take the printer offline.
2. Press the **Cancel Print** key. The current job will be canceled and removed from the queue after the printer completes the current page.
3. To restore the printer to READY status, press the **Online** key.

Printing a Stored Page (PCL5e Jobs Only)

Situation: The Page Eject indicator is lit, indicating that the printer has data stored that needs to be printed, but has not received a command to print the page.

Action:

1. Press the **Online** key to take the printer offline.
2. Press the **Page Eject** key. The page prints.

3. To restore the printer to READY status, press the **Online** key.

Note: The **Page Eject** key is valid only for PCL5e jobs; it does not print pages of PostScript or IPDS jobs.

Printing a List of PCL5e Fonts

Situation: You want to see a list of the PCL5e fonts installed on the printer.

Action:

1. Press the **Online** key to take the printer offline.
2. Press the **Menu** key. TEST MENU appears in the display area.
3. Press the **Item** key until you see PRINT PCL FONTS.
4. Press the **Continue/Enter** key to print the PCL5e fonts list.
5. After the page prints, press the **Online** key to restore the printer to READY status.

Printing a List of PostScript Fonts

Situation: You have the optional PostScript Level 2 SIMM installed on your printer and you want to see a list of the PostScript fonts.

Action:

1. Press the **Online** key to take the printer offline.
2. Press the **Menu** key. TEST MENU appears in the display area.
3. Press the **Item** key until you see PRINT PS FONTS. This item appears only if you have the optional PostScript Level 2 SIMM installed on your printer.
4. Press the **Continue/Enter** key to print the PostScript fonts list.
5. After the page prints, press the **Online** key to restore the printer to READY status.

Printing a List of IPDS Resident Fonts

Situation: You have the optional IPDS SIMM installed on your printer and you want to see a list of the IPDS resident fonts.

Action:

1. Press the **Online** key to take the printer offline.
2. Press the **Menu** key. TEST MENU appears in the display area.
3. Press the **Item** key until you see PRINT IPDS FONTS. (This item appears only if you have the optional IPDS SIMM installed on your printer.)
4. Press the **Continue/Enter** key to print the IPDS resident fonts list.
5. After the page prints, press the **Online** key to restore the printer to READY status.

Adjusting Print Density (Printing Darker or Lighter)

Situation: You want to increase or decrease the print density, making the print darker or lighter.

Action:

1. Press the **Online** key until you see OFFLINE in the display.
2. Press the **Menu** key until you see CONFIG MENU in the display.
3. Press the **Item** key until you see DENSITY=n* in the display, where n is the density value currently selected. (3 is the factory default.)
4. Press the **Value** key until you see the value you want to assign to the toner density; 12 is the darkest print, 0 is the lightest.
5. Press the **Continue/Enter** key to select the new density. An asterisk (*) appears next to the value, showing that it is active.
6. To restore the printer to READY status, press the **Online** key.

Changing the Power Savings (Sleep Mode) Interval

Situation: When you first install your printer, the printer is set up to go into power-savings mode (or sleep mode) after it is inactive for 30 minutes. In this mode, the printer powers down most of its systems and therefore requires extra time to warm up when the next print is requested.

Action:

1. Press the **Online** key until you see OFFLINE in the display.
2. Press the **Menu** key until you see CONFIG MENU in the display.
3. Press the **Item** key until you see PWRSV=30* in the display. (If this value has already been changed, a number other than 30 will appear in the display.)
4. Press the **Value** key until you see the value (number of minutes) you want to assign to the power-saver feature.
5. Press the **Continue/Enter** key to select the new power-savings value. An asterisk (*) appears next to the value, showing that it is active.
6. To restore the printer to READY status, press the **Online** key.

Changing the Language Shown on the Display Panel

Situation: You want to display operator panel messages and menus in a language other than English.

Action:

1. Press the **Online** key until you see OFFLINE in the display.
2. Press the **Shift** and **Menu** keys at the same time. You see LANGUAGE MENU.
3. Press the **Item** key. LANG=ENGLISH* appears as the first menu item unless the language has already been changed.
4. Press the **Value** key until you see the language you want to select.
5. Press the **Continue/Enter** key. An asterisk (*) appears next to the language, showing that it is active.
6. To restore the printer to READY status, press the **Online** key.

Chapter 3. Paper Handling

This chapter describes how to:

- Select print media
- Load print media into the following:
 - 250-sheet main paper tray (Tray 1)
 - 100-sheet auxiliary tray
 - 500-sheet paper tray (Tray 2, Tray 3)
 - Envelope feeder
- Use the 10-Bin Mailbox Option.
- Use the Paper Menu to specify default trays, bins, and paper sizes for your printer.

Important: Values specified in your print jobs normally override defaults set at the printer. For example, if a print job requests the 250-sheet paper tray (Tray 1), the printer will use the 250-sheet paper tray, even if the default tray is set to something else.

Also note that when mismatches occur between size and source (for example, a job specifies a specific tray and a specific paper size, but the requested tray does not contain the requested paper size), the printer attempts to satisfy the size request first. If no tray contains the requested size, a message may indicate the last tray the printer checked.

Selecting Paper and Other Printable Material

Tray or Bin	Paper Sizes & Envelope Sizes	Papers & Other Printable Material	Paper Weight
250-sheet main paper tray (Tray 1)	A4, Letter, 13-in. Legal (Folio), 14-in. Legal, Executive, B5-JIS	Copier paper Recycled paper Letterhead/preprinted paper	16- to 28-pound paper (60 grams/meter ² to 105 grams/meter ²)
100-sheet auxiliary tray	Paper sizes—A4, Letter, 13-in. Legal (Folio), 14-in. Legal, Statement, Executive, A5, A6, B5-JIS, B5-ISO Envelope sizes — Commercial #10, Monarch, DL, C5	Copier paper Recycled paper Transparencies Paper-backed labels Card stock Envelopes	16- to 28-pound paper (60 grams/meter ² to 105 grams/meter ²) for paper Up to 190 grams/meter ² for transparencies, labels, and postcards
500-sheet paper tray (Tray 2, Tray 3)	A4, Letter, 13-in. Legal (Folio), 14-in. Legal	Copier paper Recycled paper Letterhead/preprinted paper	16- to 28-pound paper (60 grams/meter ² to 105 grams/meter ²)
500-sheet offset paper output bin	A4, Letter, 13-in. Legal (Folio), 14-in. Legal, Statement, Executive, A5, A6, B5-JIS, B5-ISO	Copier paper	16- to 28-pound paper (60 grams/meter ² to 105 grams/meter ²)
Mailbox	A4, Letter	Copier paper	20- to 28-pound paper (75 grams/meter ² to 105 grams/meter ²)
Envelope feeder	Commercial #10, Monarch, DL, C5	Envelopes	16- to 28-pound paper (60 grams/meter ² to 105 grams/meter ²)

Notes:

1. Paper sizes are defined as follows:

- A4 — 210 x 297 mm
- A5 — 148.5 x 210 mm
- A6 — 105 x 148 mm
- B5-JIS — 182 x 257 mm
- B5-ISO — 176 x 250 mm
- Statement — 8.5 x 5.5 in.
- Executive — 7.25 x 10.5 in. (185 x 267 mm)
- Letter — 8.5 x 11.0 in. (216 x 279 mm)
- 13-in. Legal (Folio) — 8.5 x 13.0 in. (216 x 330 mm)
- 14-in. Legal — 8.5 x 14.0 in. (216 x 356 mm)

2. Envelope sizes are defined as follows:
 - Commercial #10 — 4.125 x 9.5 in. (104.8 x 241.3 mm)
 - C5 — 162 x 229 mm (6.48 x 9.16 in.)
 - DL — 110 x 220 mm (4.4 x 8.8 in.)
 - Monarch — 3.875 x 7.5 in. (98.4 x 190.5 mm)
3. The following paper sizes may be duplexed:
 - A4, Letter, 13-in. Legal (Folio), 14-in. Legal
4. Do not use the following types of paper and printable material in your printer:
 - Multipart forms
 - Stapled, folded, or wrinkled paper
 - Smooth or coated paper
5. Use the 100-sheet auxiliary tray to print transparencies, labels, envelopes or postcards, or the optional envelope feeder to print envelopes. Do not feed these types of print media from the paper trays.
6. The 250-sheet paper tray and the 500-sheet paper tray are not interchangeable.
7. Some recycled papers release paper dust that can accumulate and cause frequent paper jams and reduced supplies life.
8. High humidity can damage paper. Try to store paper where it is cool and dry.

Loading Paper and Envelopes into the Printer

You can add paper to your printer when the printer is off, offline, or when the READY message is displayed. If your printer has used all of the paper in the selected paper tray, LOAD paper-size IN tray is displayed in the message display area.

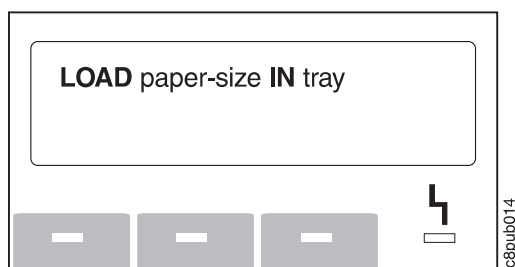

Loading Letterhead and Prepunched Paper

Your printer can print on both prepunched and preprinted paper (for example, paper with letterhead or preprinted numbers). Use the following guidelines to load the paper:

Type of Printing	Tray	Orientation
One-sided	250-sheet paper tray and 500-sheet paper tray	Place preprinted side down, with the top of the printed paper toward the front of the paper tray. If using prepunched paper, place the punched side toward the left side of the paper tray.
	100-sheet auxiliary tray	Place preprinted side up, with the top of the printed paper toward the back of the auxiliary tray If using prepunched paper, place the punched side toward the left side of the auxiliary tray.
Two-sided printing (if optional duplex unit is installed)	250-sheet paper tray and 500-sheet paper tray	Place preprinted side up, with the top of the printed paper toward the back of the printer. If using prepunched paper, place the punched side toward the left side of the paper tray.
	100-sheet auxiliary tray	Place preprinted side down, with the top of the printed paper toward the front of the tray. If using prepunched paper, place the punched side toward the left side of the auxiliary tray.

Loading Paper into the 250-Sheet Main Paper Tray (Tray 1)

Note

Many applications allow you to specify the input tray you want to use. This value will override any value set at the printer. If your application does not let you pick an input tray, use the Paper Menu to select the tray.

To select the 250-sheet main paper tray, set SOURCE to TRAY1 (see “Selecting The Default Input Tray” on page 53).

Use the following procedure to load paper into the 250-sheet paper tray:

1. Select printer paper for the 250-sheet paper tray using these guidelines:

Paper size	A4, Letter, 13-in. Legal (Folio), 14-in. Legal, Executive, or B5-JIS
Paper weight	16- to 28-pound paper (60 grams/meter ² to 105 grams/meter ²)
Paper Capacity	Up to 25 mm (1 in.) maximum stack height Up to 230 sheets of paper for A4 paper Up to 250 sheets for all other paper sizes

2. Remove the paper tray from the printer and place it on a flat surface.

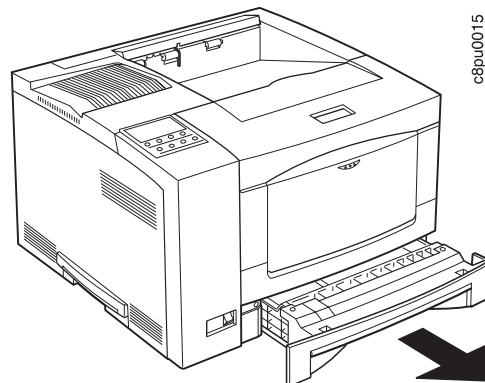

3. Press down on the bottom plate of the paper tray until it snaps into position.

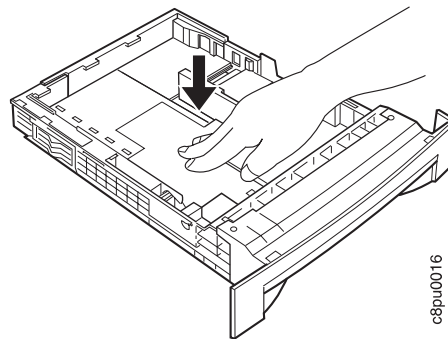

c8pu0016

4. **Important!** If you are not changing paper size, go to Step 5 on page 27. If you are inserting longer paper, do the following:
 - a. Push in on the size lock button and slide guide A out.

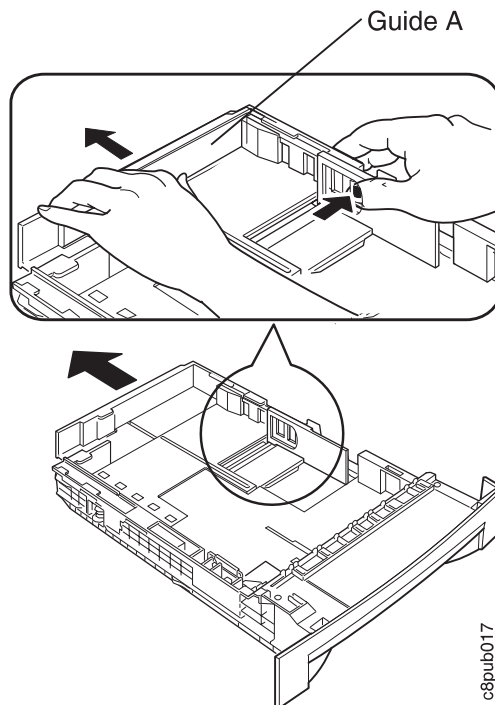

c8pub017

- b. Slide guide B out to align it with guide A.

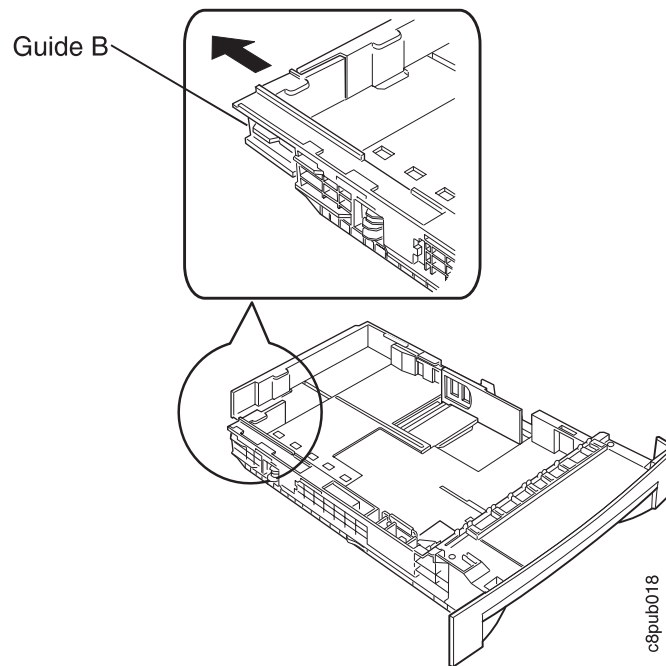

Note: If you are adding shorter paper, adjust guide B before you adjust guide A. Make sure guide B presses lightly against the end of the paper stack.

5. Insert the paper into the tray. Make sure you place the corners of the paper under the retaining clip at the front of the tray and under the plastic tabs on the end guide.

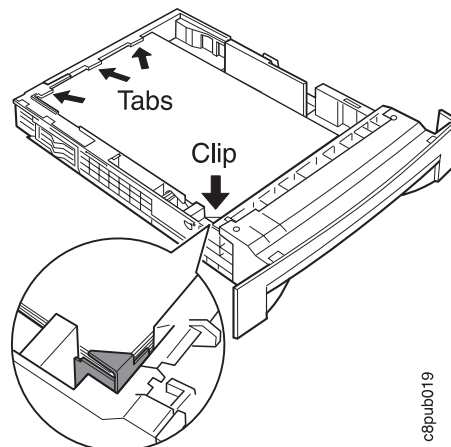

6. If the paper is narrower than the tray, adjust the size guide so that it presses lightly against the side of the paper stack. The paper should lay flat in the tray and should not be bowed.

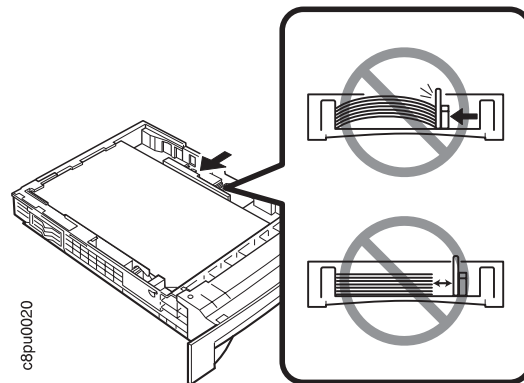

7. Gently slide the paper tray into the printer until it clicks into place.

Note: Closing the 250-sheet tray with too much force can misalign the paper guides.

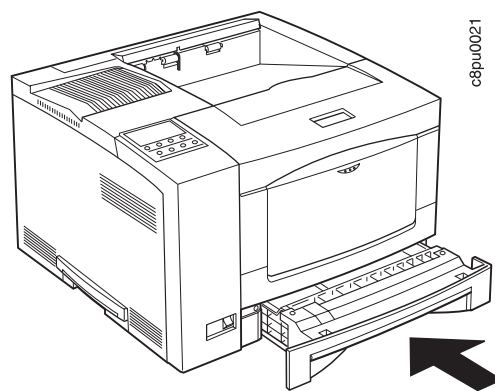

Loading Paper into the 100-Sheet Auxiliary Tray

Note

Many applications allow you to specify the input tray you want to use. This value will override any value set at the printer. If your application does not let you pick an input tray, use the Paper Menu to select the tray.

To select the 100-sheet auxiliary tray, set SOURCE to AUXTRAY. (see “Selecting The Default Input Tray” on page 53).

Use the following procedure to load paper into the 100-sheet auxiliary tray:

1. Select printer paper, transparencies, labels, or postcards for the 100-sheet auxiliary tray using these guidelines:

Paper size	A4, Letter, 13-in. Legal (Folio), 14-in. Legal, Statement, Executive, A5, A6, B5-JIS, B5-ISO, transparencies, labels, and postcards
Paper weight	16- to 28-pound paper (60 grams/meter ² to 105 grams/meter ²) for paper Up to 190 grams/meter ² for transparencies, labels, and postcards
Paper Capacity	Up to 15 mm (0.5 in.) maximum stack height Up to 100 sheets copier or Xerographic paper Up to 30 sheets for transparencies, labels, and postcards

2. Press on the top of the auxiliary tray door to open it.

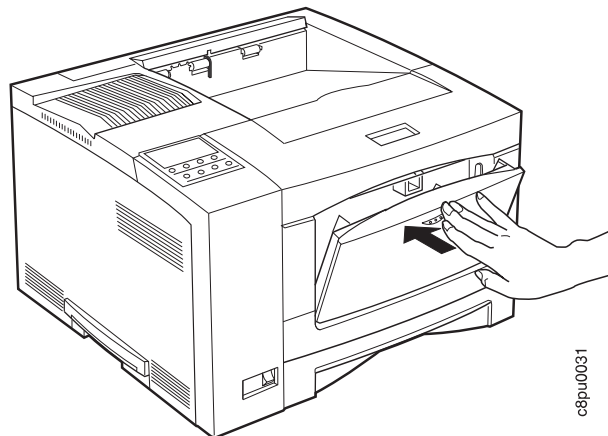

e8pu0031

3. Pull out the tray extension.

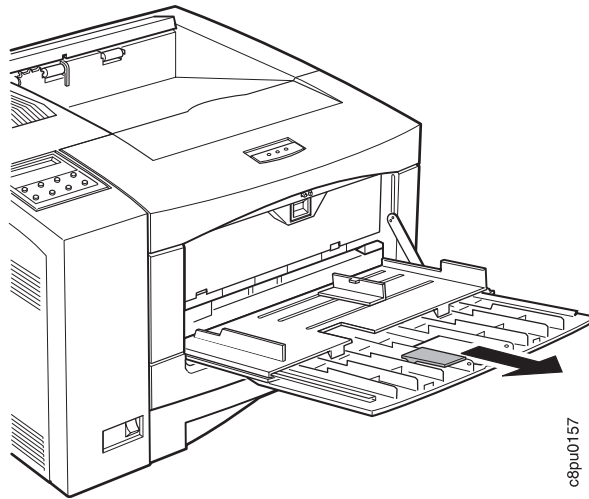

4. Insert the paper into the auxiliary tray. Make sure you place the left edge of the paper against the left side paper guide and under the plastic tab on the paper guide.

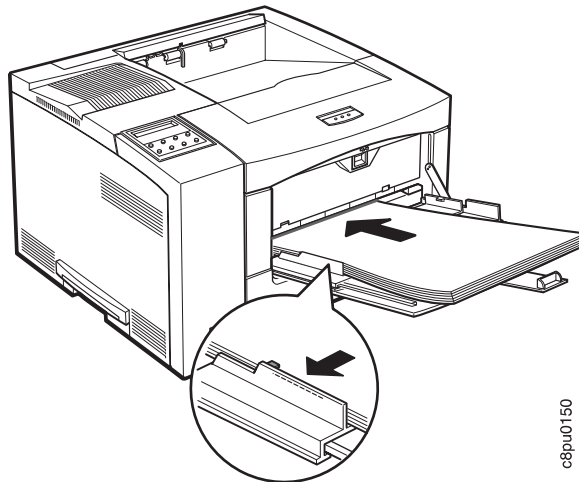

- Adjust the size guide on the right side of the auxiliary tray to the paper size. Make sure you place the edges of the paper under the retaining clip at the right side of the auxiliary tray.

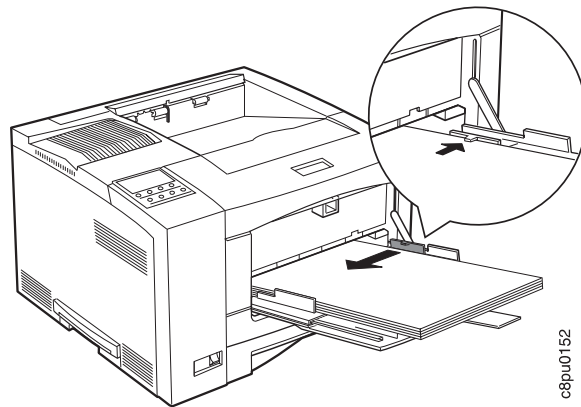

- Make sure the paper fits correctly in the auxiliary tray. The paper should lay flat in the tray and should not be bowed.

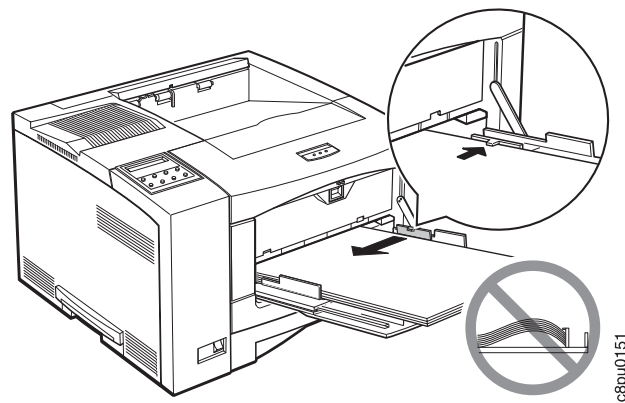

- Use your print application or the Paper Menu to set AUXSIZE to match the paper size you loaded in the auxiliary tray (see “Defining the Auxiliary Tray Paper Size” on page 54). Values specified in print jobs override values you set at the printer.

If you want to feed the paper manually into the auxiliary tray, use your print application or the Paper Menu to set MANUAL to ON (see “Paper Menu” on page 77).

Note: PostScript jobs can override MANUAL=OFF; however, they cannot override MANUAL=ON. Therefore, if you do set MANUAL to ON, make sure you reset MANUAL to OFF after you complete the jobs you want to print manually.

Loading Envelopes into the 100-Sheet Auxiliary Tray

Note

Many applications allow you to specify the input tray you want to use. This value will override any value set at the printer. If your application does not let you pick an input tray, use the Paper Menu to select the tray.

To select the 100-sheet auxiliary tray, set SOURCE to AUXTRAY (see “Selecting The Default Input Tray” on page 53).

Use the following procedure to load paper into the 100-sheet auxiliary tray:

1. Select envelopes using these guidelines:

Envelope size	Commercial #10 — 104.8 x 241.3 mm (4.125 x 9.5 in.) Monarch — 98.4 x 190.5 mm (3.875 x 7.5 in.) DL — 110 x 220 mm (4.4 x 8.8 in.) C5 — 162 x 229 mm (6.48 x 9.16 in.)
Envelope weight	16- to 28-pound paper (60 grams/meter ² to 105 grams/meter ²)
Envelope Capacity	Up to 10 envelopes for all envelope sizes

2. Press on the top of the auxiliary tray door to open it.

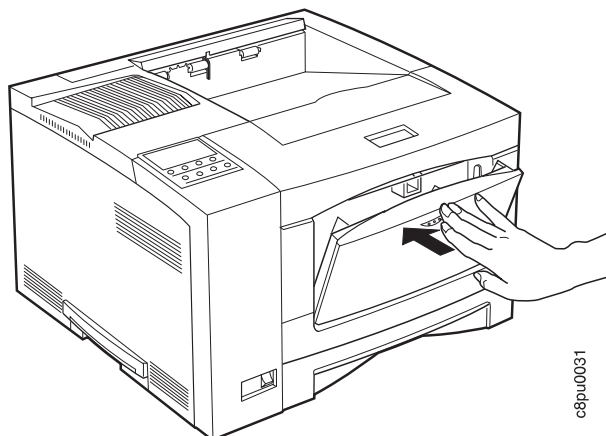

c8pu0031

3. Pull out the tray extension.

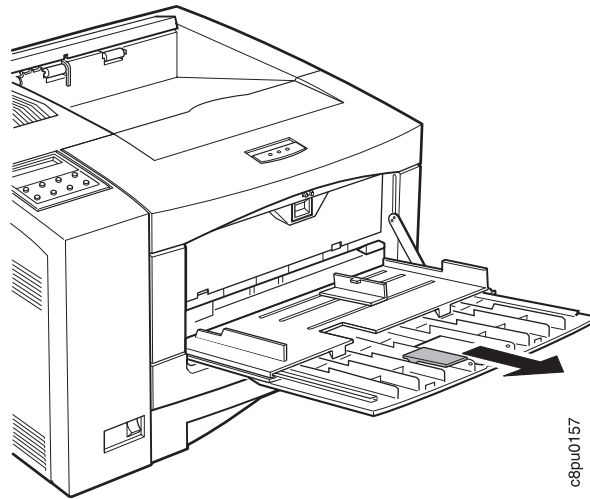

c8pu0157

4. Pull out the envelope stopper.

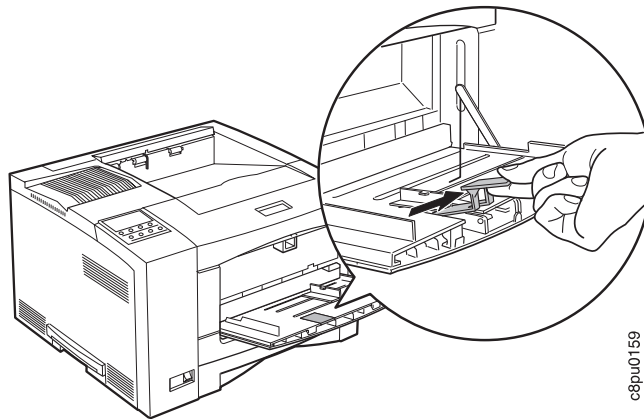

c8pu0159

5. Load the envelopes with the flap side down and the bottom edge of the envelopes toward the left side of the auxiliary tray. Make sure you place the bottom edge of the envelopes against the left side paper guide and under the plastic tab on the paper guide.

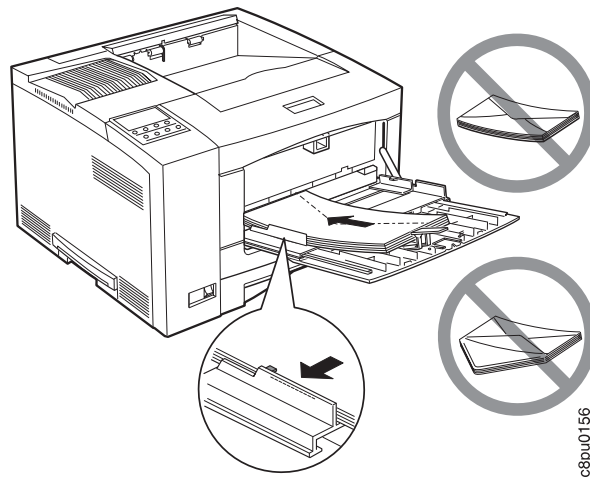

6. Adjust the size guide on the right side of the auxiliary tray to the envelope size. Make sure you place the top edge of the envelopes under the retaining clip at the right side of the auxiliary tray.

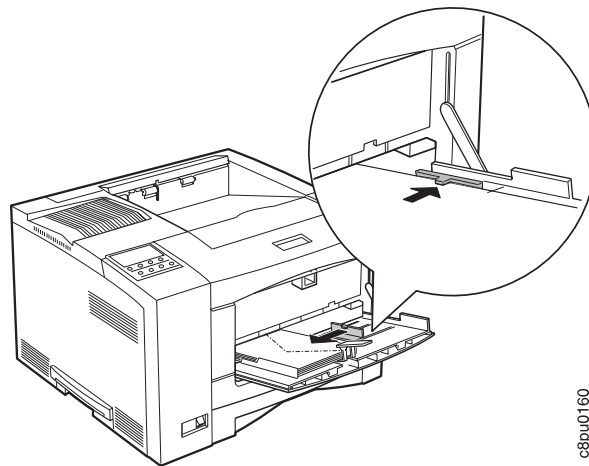

7. Push in the envelope stopper. Make sure the envelopes fit correctly in the auxiliary tray. The envelopes should lay flat in the tray and should not be bowed.

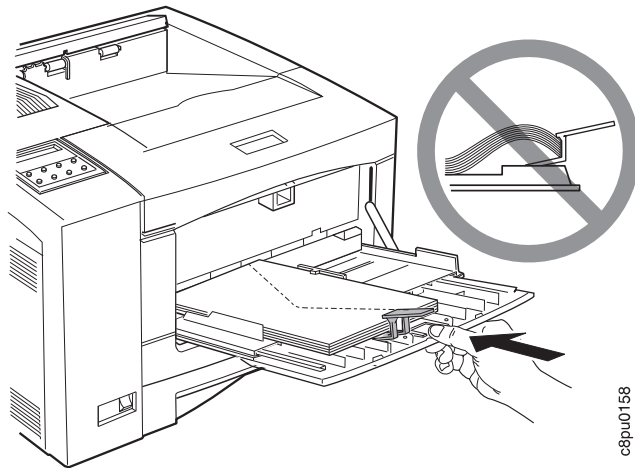

8. Use your print application or the Paper Menu to set AUXSIZE to match the envelope size you loaded in the auxiliary tray (see “Defining the Auxiliary Tray Paper Size” on page 54). Values specified in print jobs override values you set at the printer.

Loading Paper into the 500-Sheet Paper Trays (Tray 2, Tray 3)

Note

Many applications allow you to specify the input tray you want to use. This value will override any value set at the printer. If your application does not let you pick an input tray, use the Paper Menu to select the tray.

To select the 500-sheet main paper tray, set SOURCE to TRAY2 or TRAY3 (TRAY2 if you have only one 500-sheet tray or for the upper tray if you have two; TRAY3 for the lower tray if you have two. See “Selecting The Default Input Tray” on page 53.)

Use the following procedure to load paper into the 500-sheet paper tray:

1. Select printer paper for the 500-sheet paper tray using these guidelines:

Paper size	A4, Letter, 13-in. Legal (Folio), 14-in. Legal
Paper weight	16- to 28-pound paper (60 grams/meter ² to 105 grams/meter ²)
Paper Capacity	Up to 54 mm (2 in.) maximum stack height

2. Remove the 500-sheet paper tray from the printer and place on a flat surface.

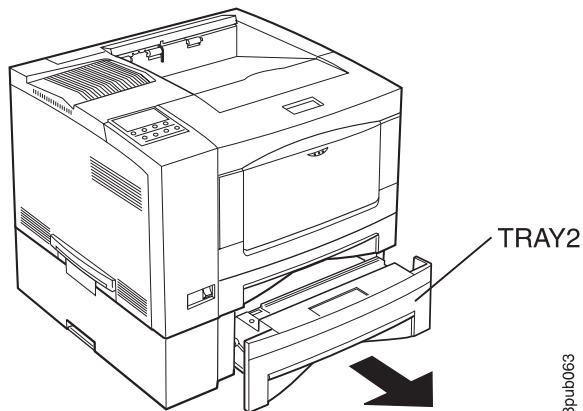

c8pub063

3. Press down on the bottom plate of the paper tray until it snaps into position.

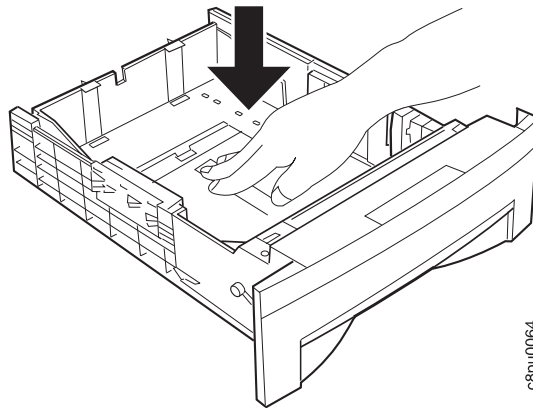

4. **Important!** If you are not changing paper size, go to Step 5 on page 38. Otherwise, adjust the paper guides as follows:

- a. Pull out on both sides while gently pushing up on the end guide. Do not push the end guide up too far.

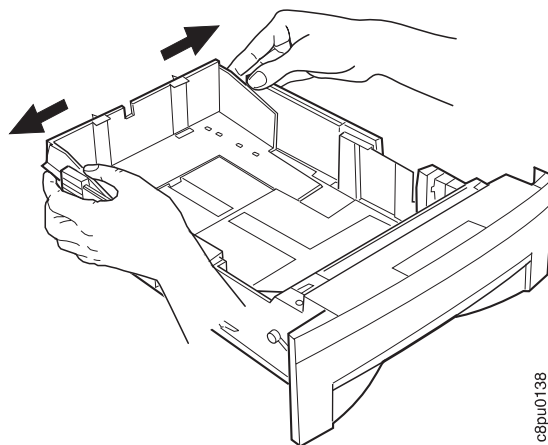

- b. Adjust the end guide to the correct paper size and push down on the end to lock it into place.

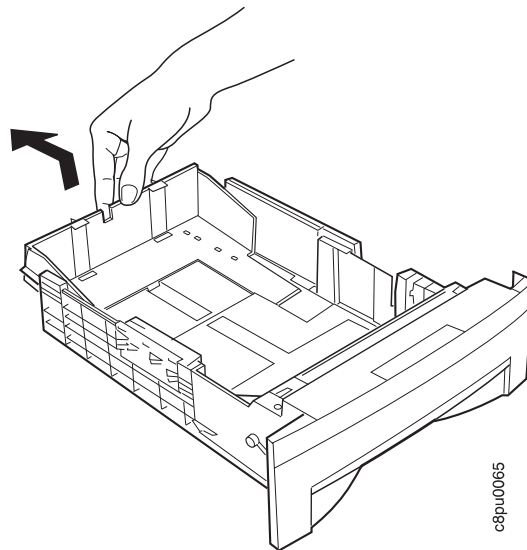

5. Insert the paper along the left side of the tray. Make sure you place the corner of the paper under the retaining clip at the front of the tray and under the plastic tabs on the end guide. Do not load paper above the maximum line.

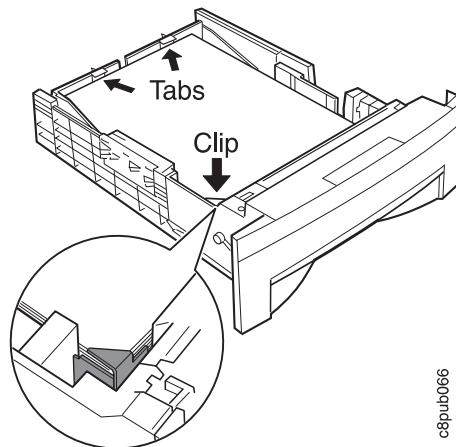

6. Press down on the gray lever on the right side of the tray and slide the size guide so that it presses lightly against the side of the paper stack. The paper should lay flat in the tray and should not be bowed.

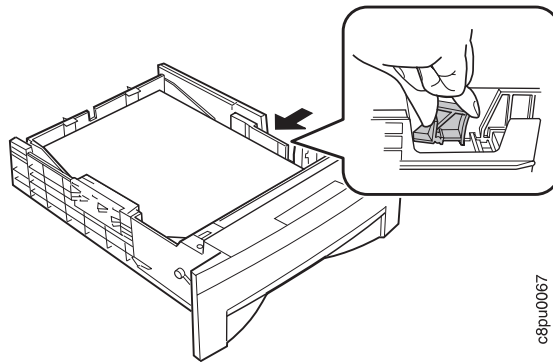

7. Slide the paper tray into the paper tray support unit until it clicks into place.

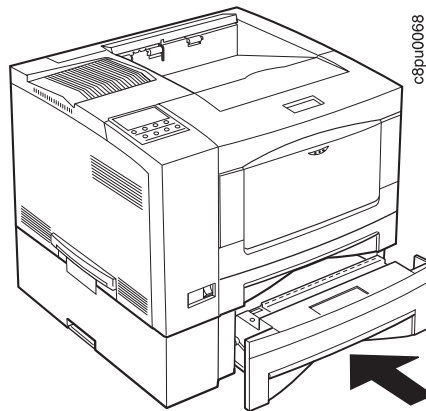

Loading Envelopes into the Envelope Feeder

Note

Many applications allow you to specify the input tray you want to use. This value will override any value set at the printer. If your application does not let you pick an input tray, use the Paper Menu to select the tray.

To select the envelope feeder, set SOURCE to ENVELOPE (see "Selecting The Default Input Tray" on page 53).

Use the following procedure to load envelopes into the envelope feeder:

1. Select envelopes using these guidelines:

Envelope size	Commercial #10 — 104.8 x 241.3 mm (4.125 x 9.5 in.) Monarch — 98.4 x 190.5 mm (3.875 x 7.5 in.) DL — 110 x 220 mm (4.4 x 8.8 in.) C5 — 162 x 229 mm (6.48 x 9.16 in.)
Envelope weight	16- to 28-pound paper (60 grams/meter ² to 105 grams/meter ²)
Envelope Capacity	Up to 75 envelopes for Commercial 10, Monarch, and DL Up to 50 envelopes for C5

2. Pull out the tray extension.

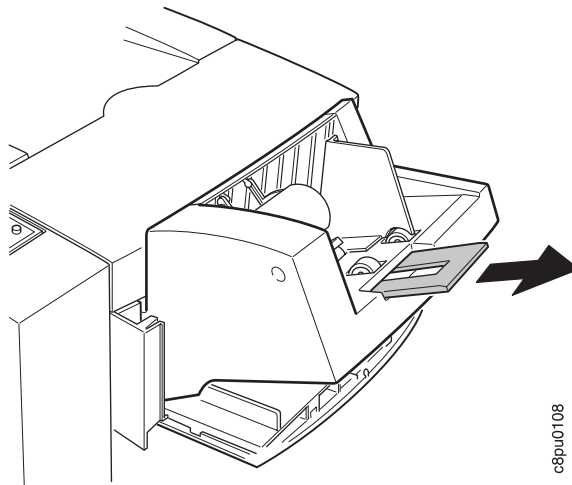

c8pu0108

3. Squeeze the size guide and slide it to the right.

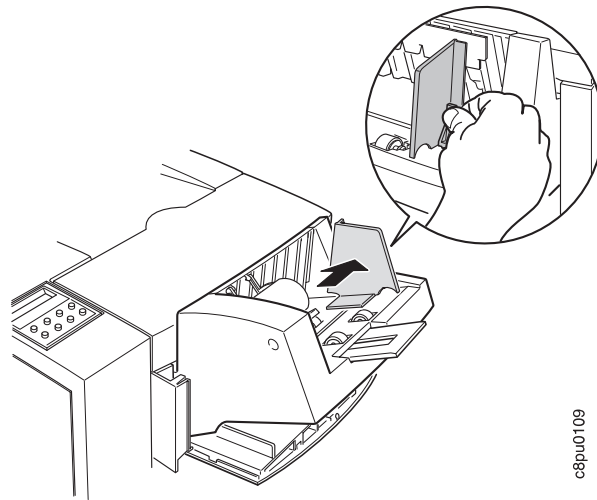

c8pu0109

4. Lift the envelope weight out of the way.



c8pu0110

5. Load closed envelopes with the flap side down and the bottom edge of the envelopes toward the left side of the envelope feeder.

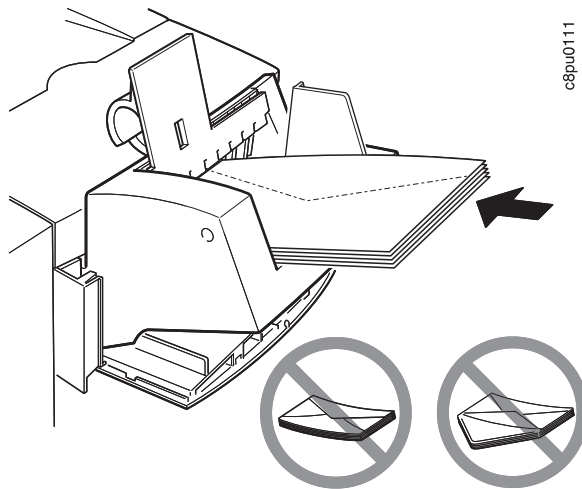

6. Adjust the size guide to the envelope size.

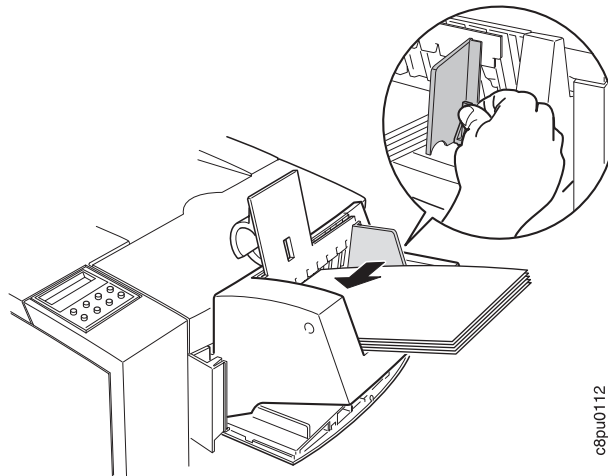

7. Lower the envelope weight onto the envelope stack.

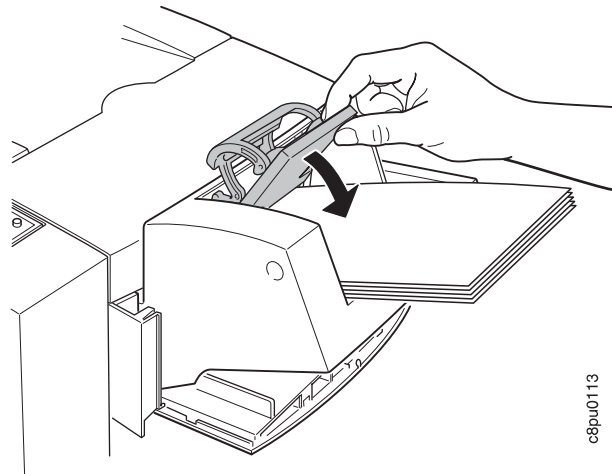

c8pu0113

8. Use the Paper Menu to set ENVSIZE to match the envelope size you loaded in the envelope feeder (see page 77).

Using the Mailbox

The optional Mailbox feature contains ten bins, each of which can hold approximately forty-five sheets of paper. In addition, individual bins can be password protected to provide security.

This section describes how to use the optional 10-bin Mailbox, including how to:

- Remove prints from a bin
- Enter a password
- Enable and disable password protection for mailbox bins
- Define and change passwords for a mailbox bin

For information on how to install the 10-Bin Mailbox, see “The 10-Bin Mailbox Option” on page 167.

Removing Prints From a Bin

1. Make sure the printer is online. (If a menu is displayed, press the **Online** key. **READY** appears in the display area.)
2. Press the Mailbox button.

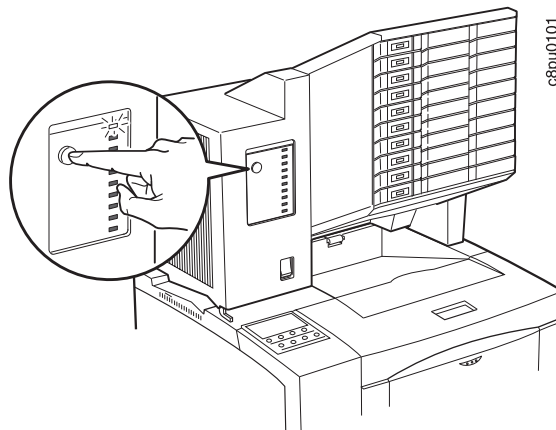

3. If your bin is not password-protected, the green indicator light next to your bin goes on when you press the Mailbox button. You can remove the print jobs from it now (go to Step 7 on page 46).

- If your bin is password protected, you need to enter your password now. A prompt asks you for the password.

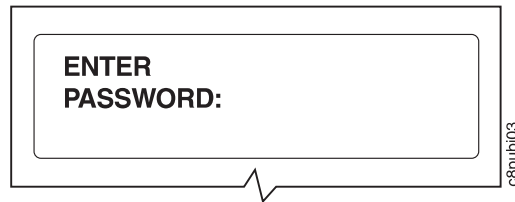

- Enter your 4-digit password. Use the table below to determine which operator panel keys correspond to each digit in your password.

To enter this number...	Press this key
0	Online
1	Continue/Enter
2	Page Eject
3	Cancel Printing
4	Menu
5	Item
6	Value
7	Shift

For example, to enter 4444, press the **Menu** key four times. To enter 4567, press the **Menu** key, press the **Item** key, press the **Value** key, and then press the **Shift** key.

- After you enter the password for the bin, the green indicator light next to your bin will light up. You can now remove your print job.

7. Pull out your bin.

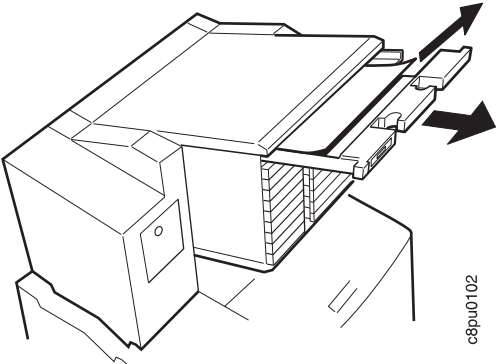

8. After you remove your job, push the bin back into place.

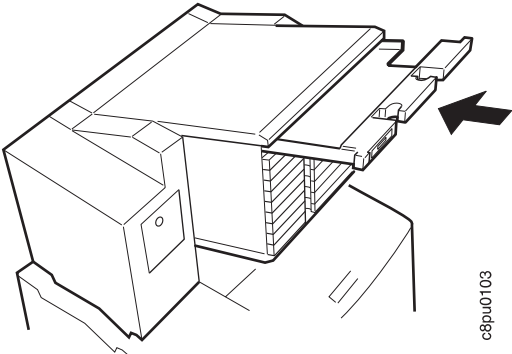

Enabling Mailbox Bin Passwords

1. Make sure the printer is offline. (If the printer is online, press the **Online** key to take it offline. OFFLINE appears in the display area.)
2. Press the **Menu** key until you see Mailbox Menu.
3. Press the **Item** key until you see the bin (BIN1 - BIN10) that needs its password enabled. In this example, we select BIN1. If your display says PW ENABLE instead of PW DISABLE, then the password is already enabled.



4. Press the **Value** key until you see BIN1=PW ENABLE.

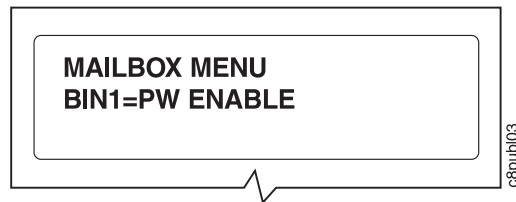

- Press the **Continue/Enter** key. If a prompt asks you for the password, enter the previous password. (If it has never been set, use the 1111 factory default).

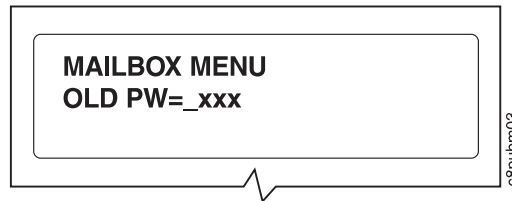

Use the table below to determine which operator panel keys correspond to each digit in your password.

To enter this number...	Press this key
0	Online
1	Continue/Enter
2	Page Eject
3	Cancel Printing
4	Menu
5	Item
6	Value
7	Shift

For example, to enter 4444, press the **Menu** key four times. To enter 4567, press the **Menu** key, press the **Item** key, press the **Value** key, and then press the **Shift** key.

- After you enter the password for the bin, you see BIN1=PW ENABLE in the display.

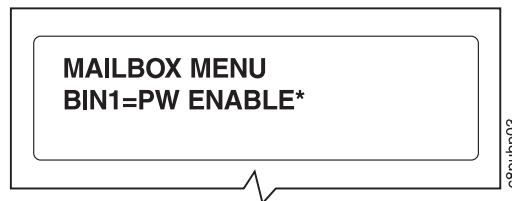

- To restore the printer to READY status, press the **Online** key.

Disabling Mailbox Bin Passwords

1. Make sure the printer is offline. (If the printer is online, press the **Online** key to take it offline. OFFLINE appears in the display area.)
2. Press the **Menu** key until you see Mailbox Menu.

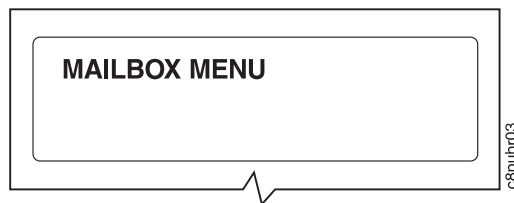

3. Press the **Item** key until you see the bin (BIN1 - BIN10) that needs its password disabled. In this example, we select BIN1. If your display says PW DISABLE instead of PW ENABLE, then password protection is already disabled.

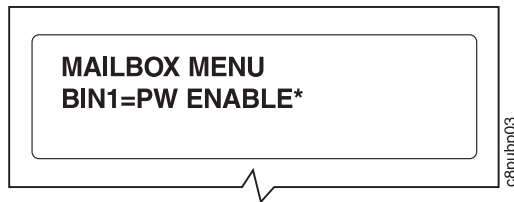

4. Press the **Value** key until you see BIN1=PW DISABLE.
5. Press the **Continue/Enter** key. A prompt asks you for the password.

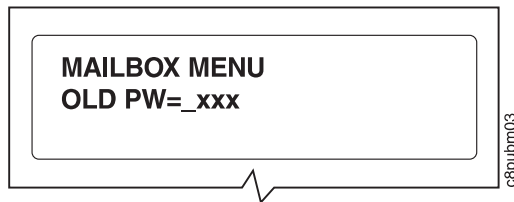

6. Enter your 4-digit password. Use the table below to determine which operator panel keys correspond to each digit.

To enter this number...	Press this key
0	Online
1	Continue/Enter
2	Page Eject
3	Cancel Printing
4	Menu
5	Item
6	Value
7	Shift

For example, to enter 4567, press the **Menu** key, press the **Item** key, press the **Value** key, and then press the **Shift** key.

7. After you enter the password for the bin, you see BIN1=PW DISABLE in the display.



8. To restore the printer to READY status, press the **Online** key.

Changing Mailbox Bin Passwords

1. Make sure the printer is offline. (If the printer is online, press the **Online** key to take it offline. OFFLINE appears in the display area.)
2. Press the **Menu** key until you see Mailbox Menu.
3. Press the **Item** key until you see the bin (BIN1 - BIN10) that needs its password changed. In this example, we select BIN1.

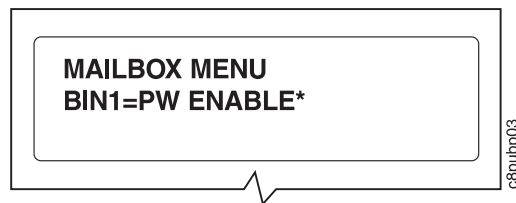

4. Press the **Value** key until you see BIN1=NEW PW.

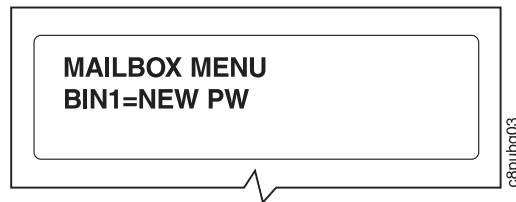

5. Press the **Continue/Enter** key. A prompt asks you for the current password.

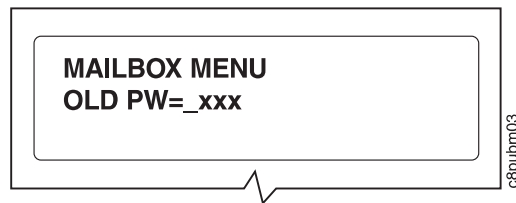

6. Enter your 4-digit password. (If this is the first time a password is being set for the bin, enter 1111.) Use the key below to determine which operator panel keys correspond to each digit in your password.

To enter this number...	Press this key
0	Online
1	Continue/Enter
2	Page Eject
3	Cancel Printing
4	Menu
5	Item
6	Value
7	Shift

For example, to enter 1111, press the **Continue/Enter** key four times. To enter 4567, press the **Menu** key, press the **Item** key, press the **Value** key, and then press the **Shift** key.

7. After you enter your old password, a prompt asks you for the new password.

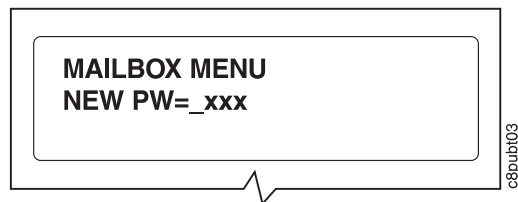

8. Enter a new 4-digit password.
9. To restore the printer to READY status, press the **Online** key.

Using the Paper Menu

This section describes some of the basic tasks you can perform using the Paper Menu, including how to:

- Select default input trays and output bins.
- Define the paper size used by the auxiliary tray and envelope feeder
- Turn tray switching on and off
- Make simplex or duplex printing the printer default

For complete information about items in the Paper Menu, see “Paper Menu” on page 77. Also, note that the printer driver or print application you use may allow you to specify values such as paper size, input tray, output bin, and manual feeding. Values set in print jobs (either by the print application or by the printer driver) override values you set at the printer.

Selecting The Default Input Tray

Situation: You want to change the default input tray for your printer.

Action:

1. Press the **Online** key until you see OFFLINE in the display.
2. Press the **Menu** key until you see PAPER MENU in the display.
3. Press the **Item** key until you see SOURCE=*source** in the display, where *source* is the current default.
4. Press the **Value** key until you see the input tray you want to use as the default. Note that the values you see depend on the options you have installed. If you have one 500-sheet tray installed, it appears as TRAY2; if you have two 500-sheet trays installed, the upper tray appears as TRAY2 and the lower tray appears as TRAY3; if you have the envelope feeder installed, it appears as ENVELOPE.
5. Press the **Continue/Enter** key to select the new tray. An asterisk appears next to the value, showing that it is active.
6. To restore the printer to READY status, press the **Online** key.

Note: Values specified in your print jobs override defaults set at the printer. For example, if a print job requests the 250-sheet paper tray, the printer will use the 250-sheet paper tray, even if the default tray is set to something else.

Selecting The Default Output Bin

Situation: You have installed the Offset Output Bin or the 10-Bin Mailbox and you want to make it the default bin.

Action:

1. Press the **Online** key until you see OFFLINE in the display.
2. Press the **Menu** key until you see PAPER MENU in the display.

3. Press the **Item** key until you see OUTPUT=*output** in the display, where *output* is the current default.
4. Press the **Value** key until you see the value you want. Note that the values you see depend on whether you have the 10-Bin Mailbox or the 500-sheet Offset Output Bin installed.
5. Press the **Continue/Enter** key to select the new bin. An asterisk appears next to the value, showing that it is active.
6. To restore the printer to READY status, press the **Online** key.

Note: Values specified in your print jobs override defaults set at the printer. If a print job requests the main bin, the printer uses it, even if the default bin is set to something else.

Defining the Auxiliary Tray Paper Size

Situation: You want to define a new paper size for the auxiliary tray.

Action:

1. Press the **Online** key until you see OFFLINE in the display.
2. Press the **Menu** key until you see PAPER MENU in the display.
3. Press the **Item** key until you see AUXSIZE=*size** in the display, where *size* is the current default.
4. Press the **Value** key until you see the new value you want.
5. Press the **Continue/Enter** key to select the new size. An asterisk appears next to the value, showing that it is active.
6. To restore the printer to READY status, press the **Online** key.

Defining the Envelope Feeder Envelope Size

Situation: You want to define a new envelope size for the optional envelope feeder.

Action:

1. Press the **Online** key until you see OFFLINE in the display.
2. Press the **Menu** key until you see PAPER MENU in the display.
3. Press the **Item** key until you see ENVSIZE=*size** in the display, where *size* is the current default.
Note: This value appears only if the optional envelope feeder is installed.
4. Press the **Value** key until you see the new value you want.
5. Press the **Continue/Enter** key to select the new size. An asterisk appears next to the value, showing that it is active.
6. To restore the printer to READY status, press the **Online** key.

Turning Tray Switching On or Off

Situation: You want to turn tray switching on or off. Tray switching specifies whether or not to switch to another paper tray if the current one is empty. When switching is ON (the default value) the printer automatically looks in other trays for the right size of paper if the current tray does not contain the paper size specified by the job. The search sequence is the default tray, followed by the 250-sheet tray (Tray 1), the first 500-sheet tray (Tray 2), the second 500-sheet tray (Tray 3), and then the auxiliary tray. OFF specifies no switching.

Action:

1. Press the **Online** key until you see OFFLINE in the display.
2. Press the **Menu** key until you see PAPER MENU in the display.
3. Press the **Item** key until you see TRAY SWITCH=ON* or TRAY SWITCH=OFF in the display.
4. Press the **Value** key until you see the new value you want.
5. Press the **Continue/Enter** key to select the new setting. An asterisk appears next to the value, showing that it is active.
6. To restore the printer to READY status, press the **Online** key.

Making Duplex or Simplex Printing the Printer Default

Situation: You want to make duplex printing or simplex printing the printer default.

Note: Values set in print jobs (either by the print application or by the printer driver) override values you set at the printer. If a print job specifies simplex printing and the printer default is duplex, the printer honors the print job setting and prints on one side only.

Action:

1. Press the **Online** key until you see OFFLINE in the display.
2. Press the **Menu** key until you see PAPER MENU in the display.
3. Press the **Item** key until you see DUPLEX=ON* or DUPLEX=OFF in the display.
4. Press the **Value** key until you see the new value you want.
5. Press the **Continue/Enter** key to select the new setting. An asterisk appears next to the value, showing that it is active.
6. To restore the printer to READY status, press the **Online** key.

Chapter 4. Clearing Paper Jams

If your printer has a paper jam, follow the procedures in this section to clear the paper jam. Note that the printer tells you the areas in which it detects paper jams. It does so by displaying a number with the PAPER JAM message.

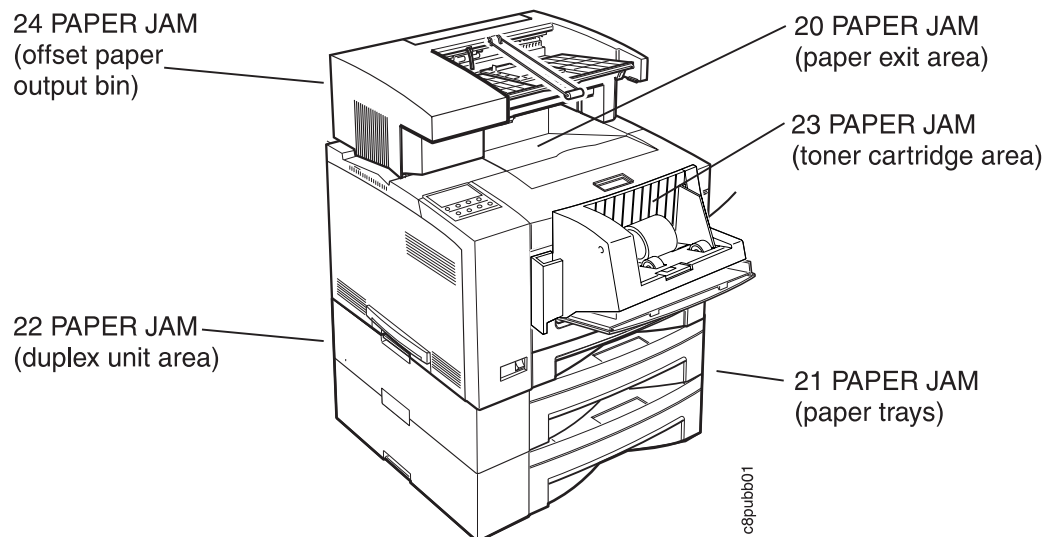

The following paper jam messages can be displayed:

- 20 PAPER JAM — Paper has jammed while exiting the printer. Go to page 58.
- 21 PAPER JAM — Paper has jammed while being picked from one of the trays. Go to page 60.
- 22 PAPER JAM — Paper has jammed in the optional duplex unit. Go to page 63.
- 23 PAPER JAM — Paper has jammed in the toner cartridge area. Go to page 68.
- 24 PAPER JAM — Paper has jammed in the optional offset paper output bin. Go to page 70.
- 25 PAPER JAM — Paper has jammed in the optional mailbox. Go to page 71.

20 PAPER JAM: Paper Exit Area

1. Carefully remove any paper that is in the paper exit.

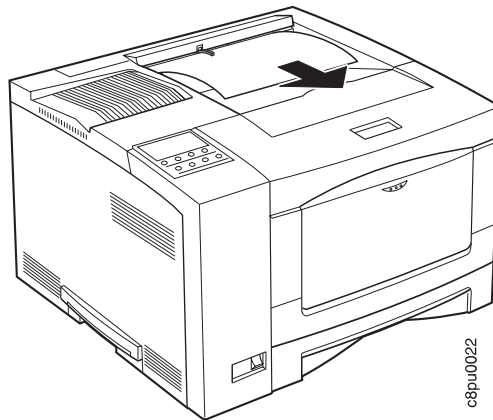

2. On the back of the printer, press the release lever and open the back cover of the printer.

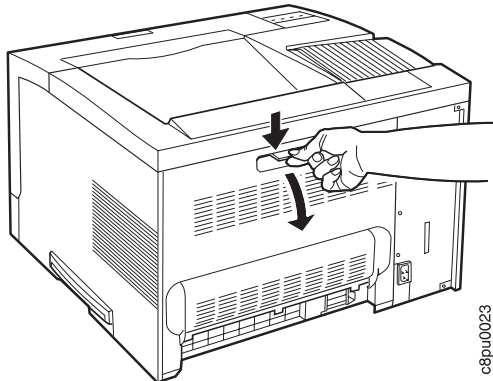

3. Locate and carefully remove paper jammed in the exit area by pulling the paper upward.

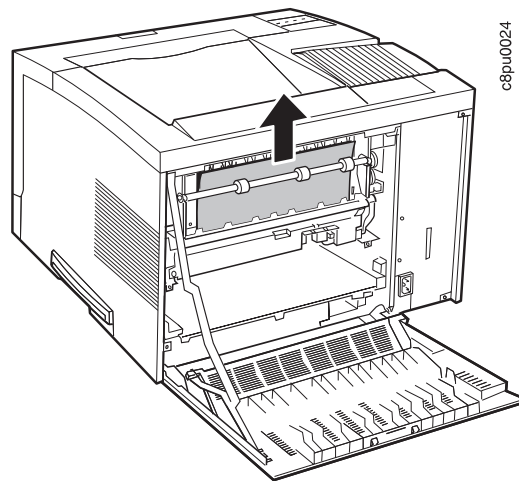

4. Close the back cover.
5. When paper gets jammed in one area of the paper path, it often gets jammed in other areas. If, after you finish this procedure, another PAPER JAM message occurs, please review all of the procedures in this chapter.

21 PAPER JAM: Paper Tray Area

1. Remove paper from the trays and feeder.
2. Remove the paper tray. If the printer is equipped with additional paper trays, remove the lowest tray.

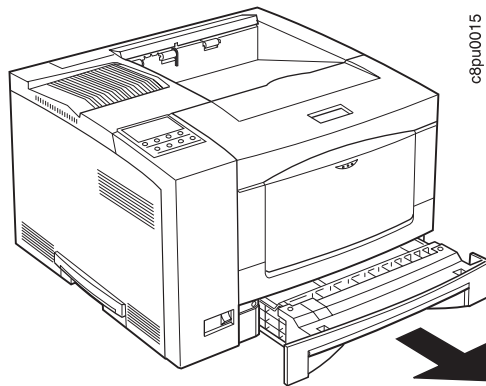

3. Make sure the paper is correctly loaded and the edges of the paper are under the corner clip and the tabs of the paper tray. See Chapter 3, "Paper Handling" on page 21 for more information.

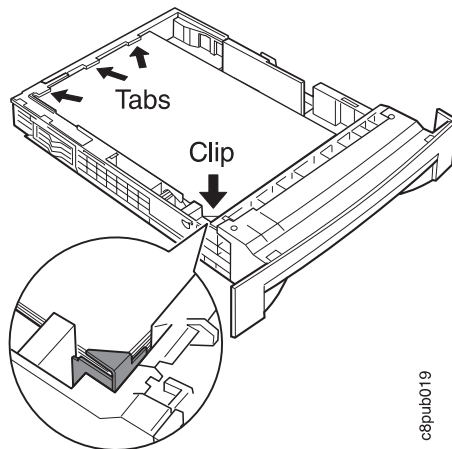

4. Remove all the paper in the paper path. Make sure the printer is free of paper. For example, locate and pull out pieces of paper that have only partially fed into the printer from the paper tray.

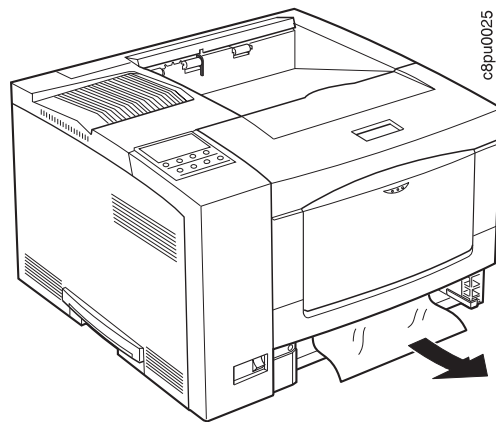

5. Push the paper tray back into the printer.
If the printer is equipped with two or three trays, repeat steps 2 on page 60 through 4 for each tray.
6. On the back of the printer, press the release lever and open the back cover of the printer.

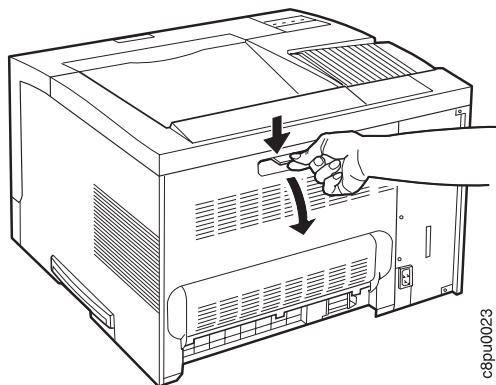

7. Locate and remove any jammed paper. To remove the paper, pull it straight out the back of the printer.

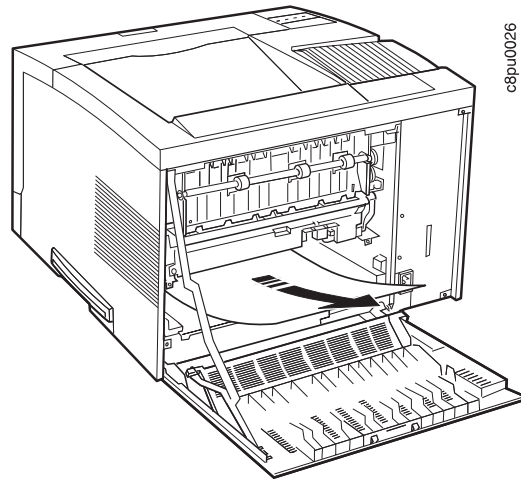

8. Close the back cover.
9. When paper gets jammed in one area of the paper path, it often gets jammed in other areas. If, after you finish this procedure, another PAPER JAM message occurs, please review all of the procedures in this chapter.

22 PAPER JAM: Duplex Unit Area

Important

Using incorrect paper sizes can cause paper jams in the duplex unit area. If you experience frequent jams in this area, please make sure you are using supported paper. Acceptable paper sizes and weights for use with the duplex unit are as follows:

Paper Size	A4, Letter, 13-in. Legal (Folio), 14-in. Legal
Paper Weight	16 lb to 28 lb (60 grams/meter ² to 105 grams/meter ²)

1. Switch the printer power off.
2. Unplug the printer from the wall outlet.
3. Remove the power cord from the back of the printer.
4. On the back of the printer, press the release lever and open the back cover of the printer.

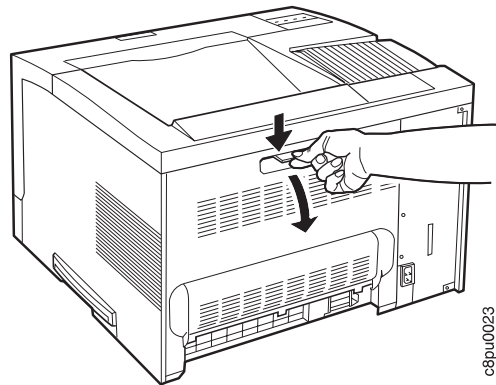

c8p10023

5. Locate and carefully pull up on the jammed paper to remove it from the exit path.

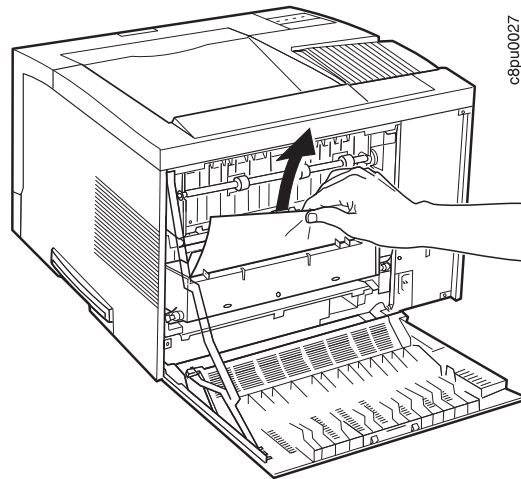

CAUTION:

Do not touch the fuser (labeled) inside the printer. It can be extremely hot. Always wait at least 40 minutes for the fuser to cool down.

6. If you cannot remove the paper easily, remove the duplex unit. Press in on the two green lock buttons located on both ends of the duplex unit and slide the unit out of the printer.

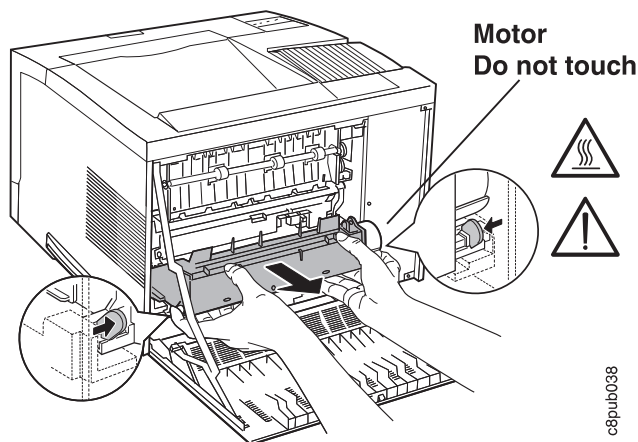

7. Carefully pull out on the jammed paper to remove it from the area behind the duplex unit.

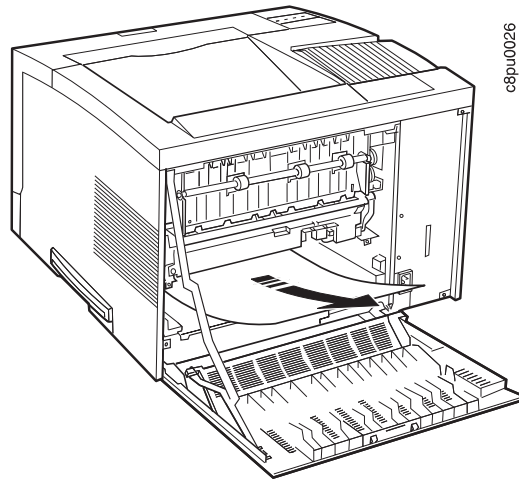

c8pu0026

8. If paper is jammed in the fuser, do the following:
 - a. Loosen the thumbscrew at the left side of the fuser cover. You may need to use a coin or a screwdriver to loosen the screws.

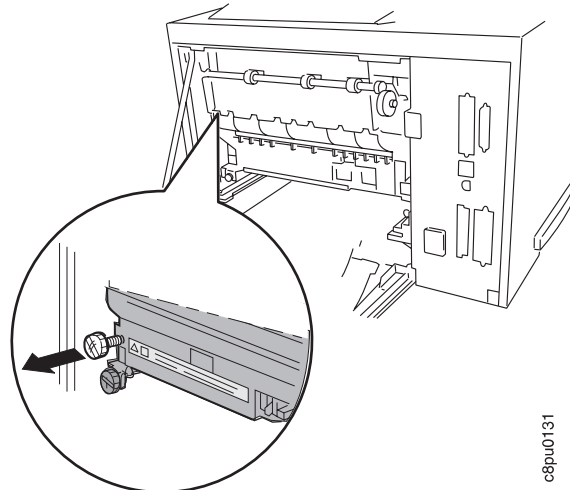

c8pu0131

b. Pull down the fuser cover.

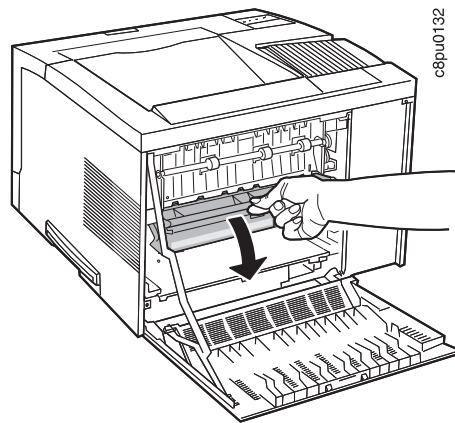

c. Remove the paper by carefully pulling it out toward the back of the printer.

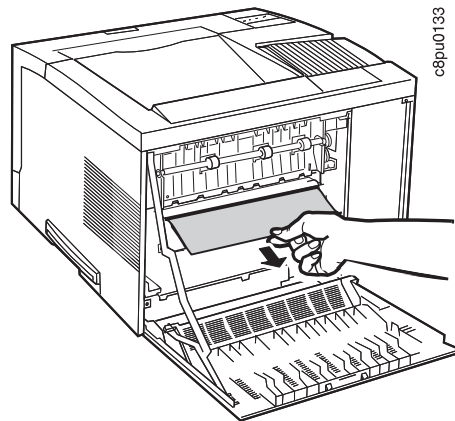

d. Close the fuser cover and replace the thumbscrew.

9. Place the duplex unit into the guide channels that are located on both sides of the back opening and slide the unit into the printer. Keep pushing until the duplex unit locks into place.

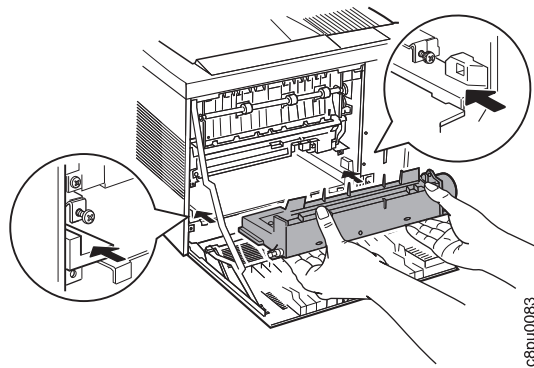

10. Close the back cover.
11. Connect the power cord to the back of the printer.
12. Connect the other end of the power cord to a grounded AC outlet.
13. Switch the printer power on.
14. When paper gets jammed in one area of the paper path, it often gets jammed in other areas. If, after you finish this procedure, another PAPER JAM message occurs, please review all of the procedures in this chapter.

23 PAPER JAM: Toner Cartridge Area

1. Remove the optional envelope feeder (if installed). See “Removing the Envelope Feeder” on page 177 for instructions.
2. Press the release button and open the front cover of the printer.

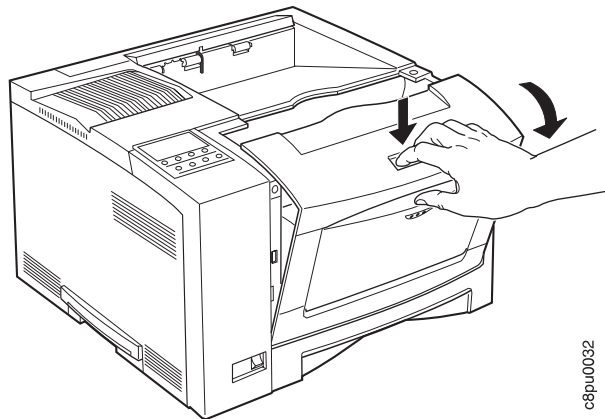

c8pu0032

3. Remove the toner cartridge.

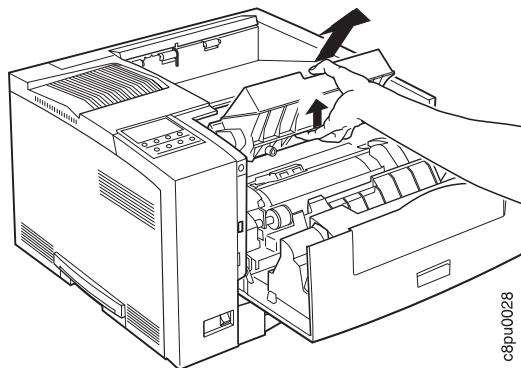

c8pu0028

4. Hold down the two green levers located on the left side of the printer and carefully remove the jammed piece of paper by pulling it toward the back of the printer.

Important: Do not pull the paper toward the front of the printer. Pulling paper toward the front of the printer can contaminate the inside of the printer with toner residue.

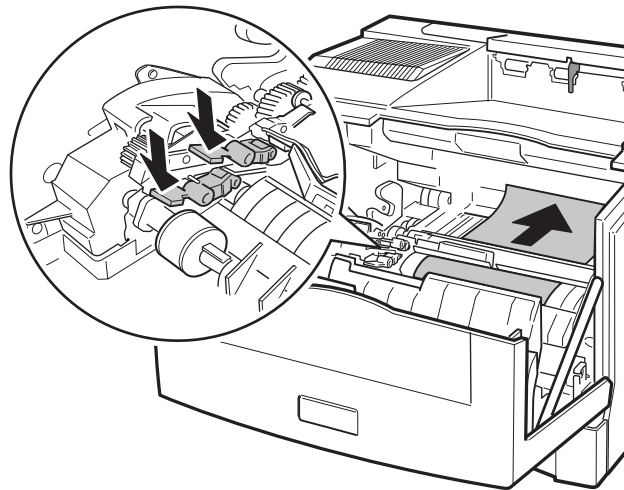

5. Close the front cover.
6. If you removed the optional envelope feeder, reinstall it. See "Installing the Envelope Feeder" on page 174 for instructions.
7. When paper gets jammed in one area of the paper path, it often gets jammed in other areas. If, after you finish this procedure, another PAPER JAM message occurs, please review all of the procedures in this chapter.

24 PAPER JAM: Offset Paper Output Bin

1. Open the back cover of the offset paper output bin.

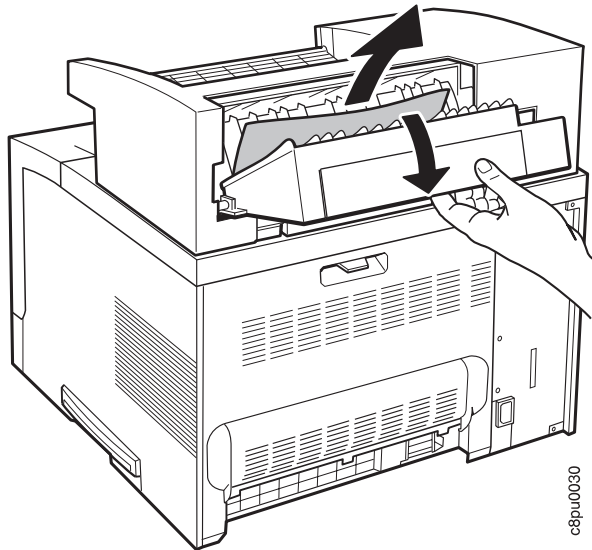

2. Remove the jammed piece of paper by pulling the paper out from the printer at an upward angle.
3. Close the back cover of the offset tray.
4. You may need to open and close the front cover of the printer to clear the error message from the operator panel display.
5. When paper gets jammed in one area of the paper path, it often gets jammed in other areas. If, after you finish this procedure, another PAPER JAM message occurs, please review all of the procedures in this chapter.

25 PAPER JAM: Mailbox

1. Open the back cover on the mailbox.
2. Remove any jammed paper.
3. Close the covers.
4. When paper gets jammed in one area of the paper path, it often gets jammed in other areas. If, after you finish this procedure, another PAPER JAM message occurs, please review all of the procedures in this chapter.

Chapter 5. Operator Panel Menus

Important

1. To see a list of menus you can access and options you have installed, print a printer configuration page. See "Printing the Printer Configuration Page" on page 13. You can use the printer configuration page as a menu map.
2. Note that several of the menus and menu items listed in this book appear on your operator panel only if you have a particular option installed.
3. If you are unfamiliar with using the operator panel to work with menus, please read "Using the Operator Panel Keys" on page 10 and "Navigating Menus" on page 12 before continuing.

This chapter describes the functions available from the printer menus. The following table describes the basic function of each menu and lists the page where you can find more information.

Use this menu	To do this	See page
TEST MENU	Print the configuration page, font lists, and printer test pages; reset the printer to use factory defaults; print a hexadecimal dump for troubleshooting purposes.	75
PAPER MENU	Select input trays, output bins, paper sizes, and duplex printing options.	77
MAILBOX MENU	Enable, disable, and set passwords for mailbox bins; define how to handle jobs after a mailbox fills up.	80
CONFIG MENU	Define how the printer handles paper jams and certain other error conditions; define toner density, power savings mode, and print quality.	81
MEMCONFIG MENU	Define whether the printer saves data stream information when it switches ports.	83
PARALLEL MENU	Define how the printer handles jobs sent through the parallel port, including the data stream, bi-directional communications, and the timeout setting.	84
PCL MENU	Define how the printer handles PCL5e jobs, including number of copies, page size, page orientation, lines per page, font source, and default font.	85
PS MENU	Define how the printer handles PostScript jobs, including number of copies and whether error messages are printed.	88
TOKEN RING MENU	Define the data stream, timeout, and network address values for the token-ring attachment.	89
ETHERNET MENU	Define the data stream, timeout, and network address values for the Ethernet attachment.	91
COAX SCS MENU	Define how the printer handles SCS jobs sent through the coaxial attachment.	93

Use this menu	To do this	See page
TWINAX SCS MENU	Define how the printer handles SCS jobs sent through the twinaxial attachment.	96
COAX SETUP MENU	Configure the coaxial environment.	98
TWINAX SETUP MENU	Configure the twinaxial environment.	100
COAX DSC/DSE MENU	Define how the printer handles DSC/DSE jobs sent through the coaxial attachment.	102
IPDS MENU	Define how the printer handles IPDS jobs.	104
MACHINE INFO MENU	Displays page counts, the error log, and the toner and fuser usage counters.	109
LANGUAGE MENU	Define the language the printer uses to display operator panel messages and menus.	110

Test Menu

Use the Test Menu to display basic information about the printer and to perform basic troubleshooting tasks.

Notes:

1. To perform the action associated with the menu item you select, press the **Continue/Enter** key.
2. The actual menu items you see depend on what options you have installed. To find out what options you have installed, print a printer configuration page. See “Printing the Printer Configuration Page” on page 13.
3. If you are unfamiliar with using the operator panel to work with menus, please read “Using the Operator Panel Keys” on page 10 and “Navigating Menus” on page 12 before continuing.
4. If IPDS is the active data stream when the printer is taken offline, the following Test Menu items will not be available:
 - CONFIG PAGE
 - PRINT PS FONTS
 - PRINT PCL FONTS
 - PRINT PS DEMO
 - PRINT SCS CHARS

These items reappear after a port timeout occurs (the length of the timeout depends on the host or network attachment you use); they also reappear if you power off the printer, wait ten seconds, and then power on.

TEST MENU ITEM	Description
CONFIG PAGE	Prints the printer configuration page. See “Printing the Printer Configuration Page” on page 13 for more information.
PRINT PS FONTS	Prints a list of PostScript fonts installed on the printer. See “Printing a List of PostScript Fonts” on page 17 for more information.
PRINT PCL FONTS	Prints a list of PCL5e fonts installed on the printer. See “Printing a List of PCL5e Fonts” on page 17 for more information.
PRINT PS DEMO	Prints the PostScript demo page.
CONTINUOUS TEST	Prints continuous test pages. To stop the test, press the Cancel Print key.
RESET PRINTER	Cancels the current print job.
PRINT IPDS FONTS	Prints a list of resident IPDS fonts installed on the printer.
PRINT SCS CHARACTERS	Prints the SCS code page (character set).

TEST MENU ITEM	Description
FACTORY DEFAULT	<p>Resets settings to the factory defaults. Note that some values do not get reset. These values include LANGUAGE, AUXSIZE, PCL SAVE, PS SAVE, BI-DI, IP ADDRESS, SUBNET MASK, GATEWAY ADDRESS, and MAC ADDRESS.</p> <p>Note: To reset all values, do one of the following:</p> <ul style="list-style-type: none"> • For A4 paper: power the printer off and then power the printer on while simultaneously pressing the Cancel Print key. • For Letter paper: power the printer off and then power the printer on while simultaneously pressing the Online key.
ONLINE HEX PRINT CANCEL ONLN HEX	ONLINE HEX PRINT prints an ASCII hexadecimal dump for troubleshooting purposes. After you select this item, it changes to CANCEL ONLN HEX. To cancel the dump, select CANCEL ONLN HEX.
CX HEX PRT CANCEL CX HEX	CX HEX PRT prints an EBCDIC hexadecimal dump of non-IPDS data coming across the coax cable; you can use the dump for troubleshooting coax problems. After you select this item, it changes to CANCEL CX HEX. To cancel the dump, select CANCEL CX HEX.
TX HEX PRT CANCEL TX HEX	TX HEX PRT prints a hexadecimal dump for troubleshooting twinax problems. After you select this item, it changes to CANCEL TX HEX. To cancel the dump, select CANCEL TX HEX.
FORMAT DISK	Formats the optional hard drive.

Paper Menu

Use the Paper Menu to select input trays, output bins, paper sizes, and duplex printing options. The following table describes the settings you can change from the Paper Menu. An asterisk (*) next to a value in the table indicates the factory default.

Notes:

1. To select a new value, press the **Continue/Enter** key when the value is displayed in the message display area. An asterisk (*) appears next to the value in the message display area, indicating that it is now active.
2. Values set in print jobs (either by the print application or the printer driver) override values you set at the printer.
3. The actual menu items you see depend on what options you have installed. To find out what options you have installed, print a printer configuration page. See “Printing the Printer Configuration Page” on page 13 for more information.
4. If you are unfamiliar with using the operator panel to work with menus, please read “Using the Operator Panel Keys” on page 10 and “Navigating Menus” on page 12 before continuing.
5. See “Using the Paper Menu” on page 53 for examples of changing values on the Paper Menu.

PAPER MENU ITEM	VALUE	Description
SOURCE	TRAY1* TRAY2 TRAY3 AUXTRAY ENVELOPE	<p>Selects the default paper tray to use. Only installed trays appear in the list.</p> <ul style="list-style-type: none"> • TRAY1 is the standard 250-sheet input tray. • TRAY2 and TRAY3 are the optional 500-sheet input trays; if you do not install them, they will not be in the list. If both are installed, TRAY2 is the upper 500-sheet tray and TRAY3 is the lower 500-sheet tray. • AUXTRAY is the flip-down tray in the front of the printer. <p>Note: If TRAY2 is installed, it is the default.</p>
OUTPUT	MAIN* OFFSET BIN1 BIN2 BIN3 BIN4 BIN5 BIN7 BIN8 BIN9 BIN10	<p>Specifies the default output bin. Note that OFFSET and BIN1-BIN10 are displayed in the menu only if you have installed the optional 500-sheet Offset Paper Tray Output and the Optional 10-Bin Mailbox.</p>

PAPER MENU ITEM	VALUE	Description
TRAY SWITCH	ON* OFF	<p>Specifies whether or not to switch to another paper tray if the current one is empty.</p> <ul style="list-style-type: none"> • ON—specifies that if the current tray does not contain the paper size specified by the job, the printer will automatically look in other trays for the right size of paper. The search sequence is the default tray, followed by the 250-sheet tray (Tray 1), the first 500-sheet tray (Tray 2), the second 500-sheet tray (Tray 3), and then the auxiliary tray. • OFF—specifies no switching. A message is displayed when a job specifies a paper size that is not available in the current tray.
MANUAL	OFF* ON	<p>Specifies whether or not paper is to be fed manually from the auxiliary tray:</p> <ul style="list-style-type: none"> • OFF—paper feeding is automatic, not manual. • ON—paper feeding is manual, one sheet at a time. Messages on the operator panel prompt you for each sheet. <p>Note: PostScript jobs can override MANUAL=OFF; however, they cannot override MANUAL=ON. Therefore, if you do set MANUAL to ON, make sure you reset MANUAL to OFF after you complete the jobs you want to print manually.</p>
AUXSIZE	LETTER* LEGAL A4 A5 EXEC COM10 MONARCH C5 DL B5-JIS B5-ISO FOLIO STAMNT A6	<p>Defines the paper or envelope size being used in the auxiliary tray.</p>
ENVSZIE	MONARCH* DL COM10 C5 A6	<p>Defines the envelope size being used in the envelope feeder.</p>
BINDING	LONG* SHORT	<p>Specifies how to print pages in duplex mode.</p> <ul style="list-style-type: none"> • LONG—prints as if the paper is to be bound along the long edge of the paper. (On the left for portrait documents, along the top for landscape documents.) • SHORT—prints as if the paper is to be bound along the short edge of the paper. (On the top for portrait documents, on the left for landscape documents.)

PAPER MENU ITEM	VALUE	Description
DUPLEX	OFF* ON	Specifies whether to print on one side or both if the duplex unit is installed. See “Making Duplex or Simplex Printing the Printer Default” on page 55 for an example.
TRAY RENUM	OFF* 1<>2	Specifies tray renumbering: <ul style="list-style-type: none"> • OFF—no tray renumbering • 1<>2—tells the printer to treat TRAY1 as TRAY2, and vice versa.

Mailbox Menu

Use the Mailbox Menu to configure the optional Mailbox attachment. The following table describes the settings you can change from the Mailbox Menu. The Mailbox Menu appears only if you have the Mailbox feature installed. An asterisk (*) next to a value in the table indicates the factory default.

Notes:

1. See “Using the Mailbox” on page 44 for information on using the Mailbox.
2. To select a new value, press the **Continue/Enter** key when the value is displayed in the message display area. An asterisk (*) appears next to the value in the message display area, indicating that is now active.
3. If you are unfamiliar with using the operator panel to work with menus, please read “Using the Operator Panel Keys” on page 10 and “Navigating Menus” on page 12 before continuing.

MAILBOX MENU ITEM	VALUE	Description
BIN1 BIN2 BIN3 BIN4 BIN5 BIN6 BIN7 BIN8 BIN9 BIN10	PW DISABLE* PW ENABLE NEW PW	Configures the mailbox bins: <ul style="list-style-type: none">• PW DISABLE—disables password protection for the bin.• PW ENABLE—enables password protection for the bin.• NEW PW—lets you set or change the password for the bin.
BIN FULL	STOP* STDBIN	Specifies how the printer should handle jobs for bins that are full. <ul style="list-style-type: none">• STOP—no more jobs are printed until the bin is emptied.• STDBIN—jobs are printed and routed to the default output bin.

Configuration (Config) Menu

Use the Configuration Menu to configure the printer. The following table describes the settings you can change from the Configuration Menu. An asterisk (*) next to a value in the table indicates the factory default.

Notes:

1. To select a new value, press the **Continue/Enter** key when the value is displayed in the message display area. An asterisk (*) appears next to the value in the message display area, indicating that it is now active.
2. Values set in print jobs (either by the print application or the printer driver) override values you set at the printer.
3. If you are unfamiliar with using the operator panel to work with menus, please read “Using the Operator Panel Keys” on page 10 and “Navigating Menus” on page 12 before continuing.

CONFIG MENU ITEM	VALUE	Description
JAMRECOVERY	OFF* ON	Sets the JAMRECOVERY function on or off. <ul style="list-style-type: none"> • OFF—the printer does not keep an image of the printed page. Jammed pages are not reprinted. • ON—the printer keeps the image for a printed page until the page successfully exits the printer. Jammed pages are automatically reprinted. Selecting ON can decrease the performance of your printer.
AUTOCONTINU	ON* OFF	Sets the auto-continue function on or off. <ul style="list-style-type: none"> • ON—following certain types of errors (such as memory allocation errors), the printer pauses for thirty seconds, and then continues running. • OFF—following the same types of errors, the printer stops and waits for operator intervention. (Generally, the operator either presses the Continue/Enter key to continue printing, or the Cancel Print key to cancel the current job.)
DENSITY	nn	Sets the toner density. nn can be from 0 to 12 where 0 is the least dense (lightest) and 12 is the most dense (darkest). 3 is the default value.
PWRSAV	30 MIN* 1HR 2HR 3HR 4HR OFF 15 MIN	Specifies how long the printer is inactive before it goes into power-savings (sleep) mode. In this mode, the printer powers down most of its systems and therefore requires extra time to warm up when the next print is requested.

CONFIG MENU ITEM	VALUE	Description
QUALITY	NORMAL* REFINE ECONO	<p>Specifies the print quality.</p> <ul style="list-style-type: none"> • NORMAL—normal quality. • REFINE—tells the printer to smooth edges. • ECONO—tells the printer to produce lighter output, thus saving toner. <p>Note: The printer driver term for REFINE is Edge Refinement.</p>

Memory Configuration (Memconfig) Menu

Use the Memory Configuration Menu to define whether or not the printer saves data stream information when it switches ports. The following table describes the settings you can change from the Memory Configuration Menu. An asterisk (*) next to a value in the table indicates the factory default.

Notes:

1. To select a new value, press the **Continue/Enter** key when the value is displayed in the message display area. An asterisk (*) appears next to the value in the message display area, indicating that it is now active.
2. The actual menu items you see depend on how much memory and what options you have installed. If you do not have enough memory, this menu will not appear at all. For information about memory requirements, see “Memory Requirements” on page 3. To find out how much memory you have installed, print a printer configuration page. See “Printing the Printer Configuration Page” on page 13 for more information.
3. If you are unfamiliar with using the operator panel to work with menus, please read “Using the Operator Panel Keys” on page 10 and “Navigating Menus” on page 12 before continuing.

MEMCONFIG MENU ITEM	VALUE	Description
PCL SAVE	OFF* ON	Specifies whether or not the printer saves PCL5e information (downloaded fonts, macros, patterns) when it switches from PCL5e to another data stream: <ul style="list-style-type: none">• OFF—the printer does not save data.• ON—the printer saves data. This option appears only when your printer has enough memory installed. See “Memory Requirements” on page 3 for more information about memory requirements.
PS2 SAVE	OFF* ON	Specifies whether or not the printer saves PostScript information (downloaded fonts, macros, patterns) when it switches from PostScript to another data stream: <ul style="list-style-type: none">• OFF—the printer does not save data.• ON—the printer saves data. This option appears only when your printer has enough memory installed. See “Memory Requirements” on page 3 for more information about memory requirements.

Parallel Menu

Use the Parallel Menu to define how the printer handles communications over the parallel attachment. The following table describes the settings you can change from the Parallel Menu. An asterisk (*) next to a value in the table indicates the factory default.

Notes:

1. To select a new value, press the **Continue/Enter** key when the value is displayed in the message display area. An asterisk (*) appears next to the value in the message display area, indicating that it is now active.
2. If you are unfamiliar with using the operator panel to work with menus, please read "Using the Operator Panel Keys" on page 10 and "Navigating Menus" on page 12 before continuing.

PARALLEL MENU ITEM	VALUE	Description
PERSONALTY	AUTO* PCL PS	Specifies how the printer treats jobs it receives over the parallel attachment. <ul style="list-style-type: none">• AUTO—the printer determines if the data stream is PCL5e or PostScript and handles it accordingly. This is the recommended value.• PCL—the printer treats all data streams as PCL5e.• PS—the printer treats all data streams as PostScript. This option appears only if the PostScript SIMM is installed.
BI-DI	ON* OFF	Turns bi-directional communications over the parallel attachment on or off. <ul style="list-style-type: none">• ON—the printer receives and sends messages to the host.• OFF—the printer receives messages from the host, but does not send messages back.
PORT TMEOUT	nnn	Specifies how many seconds the printer waits for data before it determines there is no more data to receive for the job. The printer then checks other attachments for jobs, if other attachments are installed. The valid range is 5 to 300 seconds. The default value is 15 seconds.

PCL Menu

Use the PCL Menu to define the way the printer handles PCL5e jobs. The following table describes the settings you can change from the PCL Menu. An asterisk (*) next to a value in the table indicates the factory default.

Notes:

1. To select a new value, press the **Continue/Enter** key when the value is displayed in the message display area. An asterisk (*) appears next to the value in the message display area, indicating that it is now active.
2. Values set in PCL5e print jobs (either by the print application or the printer driver) override PCL Menu values you set at the printer.
3. If you are unfamiliar with using the operator panel to work with menus, please read “Using the Operator Panel Keys” on page 10 and “Navigating Menus” on page 12 before continuing.

PCL MENU ITEM	VALUE	Description
PAGEPROT	AUTO* ON	Sets page protection: <ul style="list-style-type: none"> • AUTO—the printer uses the minimum amount of memory necessary to print a page. • ON—the printer reserves enough memory to process an entire page without compression before it prints the page. This can help in the rare case where the printer compression scheme causes a loss of quality in complex graphics. This setting is available only when the printer has enough memory. See “Memory Requirements” on page 3 for more information.
COPIES	nnn	Specifies how many copies of each job to print. nnn can be from 1 to 999. 1 is the default.
PAGESIZE	LETTER* LEGAL A4 A5 EXEC COM10 MONARC C5 DL B5-JIS B5-ISO FOLIO STAMNT A6	Specifies the default page size for PCL5e jobs.
ORIENTATION	P* L	Specifies the default page orientation. <ul style="list-style-type: none"> • P—portrait (taller than wide) • L—landscape (wider than tall)

PCL MENU ITEM	VALUE	Description
EDGE-EDGE	OFF* ON	Turns edge-to-edge printing on or off. <ul style="list-style-type: none"> • OFF—the printer maintains a border of 4 mm on all four paper sides. • ON—The printer allows printing up to the physical page size. <p>Note: To avoid toner contaminating the printer, IBM recommends leaving EDGE-EDGE set to OFF; use ON only when necessary.</p>
FORM	nnn LINES	Specifies the number of lines per page the printer prints before it starts a new page. nnn can be from 5 to 128. 60 is the default.
FNTSRC	INTERNAL* SOFT	Specifies which font source the printer checks first for a specified font: <ul style="list-style-type: none"> • INTERNAL—use the printer's resident fonts first • SOFT—use downloaded fonts first
FONTNUM	nnn	Specifies the default font. nnn is the number of the font. The default is 0. To display a list of available fonts and their corresponding numbers, select PRINT PCL FONTS from the Test Menu. See "Printing a List of PCL5e Fonts" on page 17 for more information.
PTSIZE	nn.nn	Specifies the point size of the default font, if it is an outline font. Valid values are 4 to 999.75. The default is 12.
PITCH	nn.nn	Specifies the pitch to use for the default font, if the font is bitmapped (raster). Valid values are .44 to 99.99. The default is 10.

PCL MENU ITEM	VALUE	Description
SYMSET	ROMAN-8* ISO L1 ISO L2 ISO L5 PC-8 PC-8D/N PC-850 PC-852 PC8-TK WIN L1 WIN L2 WIN L5 DESKTOP PS TEXT VN INTL VN US MS PUBL MATH-8 PS MATH VN MATH PI FONT LEGAL ISO 4 ISO 6 ISO 11 ISO 15 ISO 17 ISO 21 ISO 60 ISO 69 WIN 3.0	Specifies the symbol set to use.

PS Menu

Use the PS Menu to define the way the printer handles PostScript jobs. The following table describes the settings you can change from the PS Menu. An asterisk (*) next to a value in the table indicates the factory default. The PS Menu appears only if you have the PostScript SIMM installed.

Notes:

1. To select a new value, press the **Continue/Enter** key when the value is displayed in the message display area. An asterisk (*) appears next to the value in the message display area, indicating that it is now active.
2. Values set in PostScript print jobs (either by the print application or the printer driver) override PS Menu values you set at the printer.
3. If you are unfamiliar with using the operator panel to work with menus, please read “Using the Operator Panel Keys” on page 10 and “Navigating Menus” on page 12 before continuing.

PS MENU ITEM	VALUE	Description
PAGEPROT	AUTO* ON	Sets page protection: <ul style="list-style-type: none">• AUTO—the printer uses the minimum amount of memory necessary to print a page.• ON—the printer reserves enough memory to process an entire page without compression before it prints the page. This can help in the rare case where the printer compression scheme causes a loss of quality in complex graphics. This setting is available only when the printer has enough memory. See “Memory Requirements” on page 3 for more information.
COPIES	nnn	Specifies how many copies of each job to print. nnn can be from 1 to 999. 1 is the default.
PRINT ERRS	OFF* ON	Specifies how the printer handles PostScript errors: <ul style="list-style-type: none">• OFF—the printer cancels the job, but does not print an error page.• ON—the printer prints an error page and cancels the job.

Token Ring Menu

Important

For information about configuring the token-ring attachment, please see *IBM Network Printers: Ethernet and Token Ring Configuration Guide*, which comes with the Token-Ring Network Interface Card. Chapter 8, "Configuring Printer Network Addresses" on page 179 describes how to define the IP address, default gateway address, and subnet mask from the operator panel.

Use the Token Ring Menu to configure the token-ring attachment. The following table describes the settings you can change from the Token Ring Menu. An asterisk (*) next to a value in the table indicates the factory default. The Token Ring Menu appears only if you have the token-ring attachment installed.

Notes:

1. To select a new value, press the **Continue/Enter** key when the value is displayed in the message display area. An asterisk (*) appears next to the value in the message display area, indicating that is now active.
2. If you are unfamiliar with using the operator panel to work with menus, please read "Using the Operator Panel Keys" on page 10 and "Navigating Menus" on page 12 before continuing.

TOKEN RING MENU ITEM	VALUE	Description
PERSONALTY	AUTO* PCL PS IPDS	Specifies how the printer treats jobs it receives over the token-ring attachment: <ul style="list-style-type: none">• AUTO—the printer examines the data stream and handles it accordingly.• PCL—the printer treats all data streams as PCL5e.• PS—the printer treats all data streams as PostScript. This option appears only if the PostScript SIMM is installed.• IPDS—the printer treats all data streams as IPDS. This option appears only if the IPDS SIMM is installed.
PORT TMEOUT	nnn	Specifies the number of seconds the printer waits for data before it determines there is no more data to receive for the job. The printer then checks other attachments for jobs, if other attachments are installed. Valid values are 5 to 300. The default is 15 seconds.
IP ADDRESS	nnn.nnn.nnn.nnn	Specifies the printer's internet protocol address. Consult with your network or LAN administrator before changing this value. See Chapter 8, "Configuring Printer Network Addresses" on page 179 for more information.

TOKEN RING MENU ITEM	VALUE	Description
SUBNET MASK	nnn.nnn.nnn.nnn	Specifies the printer's subnet mask. Consult with your network or LAN administrator before changing this value. See Chapter 8, "Configuring Printer Network Addresses" on page 179 for more information.
GATEWAY ADDRESS	nnn.nnn.nnn.nnn	Specifies the IP address of the default gateway. Consult with your network or LAN administrator before changing this value. See Chapter 8, "Configuring Printer Network Addresses" on page 179 for more information.
MAC ADDRESS	nn.nn.nn.nn.nn.nn	<p>Specifies the MAC (medium access control) number of the printer.</p> <p>Note: Normally, the MAC ADDRESS should be set to the unique MAC ADDRESS on the network interface card. You can, however, also use the MAC ADDRESS field to define locally administered addresses (LAA). Resetting the printer to factory defaults sets the LAA back to the MAC address. Each LAA must be unique, so make sure to consult with your network or LAN administrator before changing this value.</p> <p>See "Setting the Locally Administered MAC Address (LAA)" on page 181 for more information.</p>

Ethernet Menu

Important

For information about configuring the Ethernet attachment, please see *IBM Network Printers: Ethernet and Token Ring Configuration Guide*, which comes with the Ethernet Network Interface Card. Chapter 8, “Configuring Printer Network Addresses” on page 179 describes how to define the IP address, default gateway address, and subnet mask from the operator panel.

Use the Ethernet Menu to configure the Ethernet attachment. The following table describes the settings you can change from the Ethernet Menu. An asterisk (*) next to a value in the table indicates the factory default. The Ethernet Menu appears only if you have the Ethernet attachment installed.

Notes:

1. To select a new value, press the **Continue/Enter** key when the value is displayed in the message display area. An asterisk (*) appears next to the value in the message display area, indicating that it is now active.
2. If you are unfamiliar with using the operator panel to work with menus, please read “Using the Operator Panel Keys” on page 10 and “Navigating Menus” on page 12 before continuing.

ETHERNET MENU ITEM	VALUE	Description
PERSONALTY	AUTO* PCL PS IPDS	Specifies how the printer treats jobs it receives over the Ethernet attachment: <ul style="list-style-type: none">• AUTO—the printer examines the data stream and handles it accordingly.• PCL—the printer treats all data streams as PCL5e.• PS—the printer treats all data streams as PostScript. This option appears only if the PostScript SIMM is installed.• IPDS—the printer treats all data streams as IPDS. This option appears only if the IPDS SIMM is installed.
PORT TMEOUT	nnn	Specifies the number of seconds the printer waits for data before it determines there is no more data to receive for the job. The printer then checks other attachments for jobs, if other attachments are installed. Valid values are 5 to 300. The default is 15 seconds.
IP ADDRESS	nnn.nnn.nnn.nnn	Specifies the printer's internet protocol address. Consult with your network or LAN administrator before changing this value. See Chapter 8, “Configuring Printer Network Addresses” on page 179 for more information.

ETHERNET MENU ITEM	VALUE	Description
SUBNET MASK	nnn.nnn.nnn.nnn	Specifies the printer's subnet mask. Consult with your network or LAN administrator before changing this value. See Chapter 8, "Configuring Printer Network Addresses" on page 179 for more information.
GATEWAY ADDRESS	nnn.nnn.nnn.nnn	Specifies the IP address of the default gateway. Consult with your network or LAN administrator before changing this value. See Chapter 8, "Configuring Printer Network Addresses" on page 179 for more information.
MAC ADDRESS	nn.nn.nn.nn.nn.nn	<p>Specifies the MAC (medium access control) number of the printer.</p> <p>Note: Normally, the MAC ADDRESS should be set to the unique MAC ADDRESS on the network interface card. You can, however, also use the MAC ADDRESS field to define locally administered addresses (LAA). Resetting the printer to factory defaults sets the LAA back to the MAC address. Each LAA must be unique, so make sure to consult with your network or LAN administrator before changing this value.</p> <p>See "Setting the Locally Administered MAC Address (LAA)" on page 181 for more information.</p>

Coax SCS Menu

Use the Coax SCS Menu to define how the printer handles SCS communications over the coax attachment. The following table describes the settings you can change from the Coax SCS Menu. An asterisk (*) next to a value in the table indicates the factory default. The Coax SCS Menu appears only if you have the coax attachment installed.

Notes:

1. To select a new value, press the **Continue/Enter** key when the value is displayed in the message display area. An asterisk (*) appears next to the value in the message display area, indicating that it is now active.
2. Values set in print jobs (either by the print application or the printer driver) override Coax SCS Menu values set at the printer.
3. For more information about configuring the coax attachment, see *IBM Network Printers: Twinax/Coax Configuration Guide*.
4. If you are unfamiliar with using the operator panel to work with menus, please read "Using the Operator Panel Keys" on page 10 and "Navigating Menus" on page 12 before continuing.

COAX SCS MENU ITEM	VALUE	Description
TRAY1 TRAY2 TRAY3 AUX	COR* C-PORT PORT LAND	<p>Specifies the default orientation for jobs printed from each tray. TRAY1 is the standard 250-sheet input tray. TRAY2 is the optional 500-sheet input tray if only one 500-sheet tray is installed, it is the upper 500-sheet tray if two 500-sheet trays are installed. TRAY3 is the lower 500-sheet tray when two 500-sheet trays are installed. Each input can be assigned one of the following default orientations:</p> <ul style="list-style-type: none">• COR—computer output reduction: Printing in landscape with the logical page reduced to fit more data on the physical page. The printer reduces vertical spacing and uses a smaller font with less space between letters.• C-PORT—compressed portrait: printing in portrait, but with spaces reduced between characters (horizontal compression) so that more text fits on a line. This allows more characters per line.• PORT—portrait: the page has normal, upright business letter orientation. For envelopes from the auxiliary tray, PORT specifies normal envelope orientation.• LAND—landscape: the page is wider than long.

COAX SCS MENU ITEM	VALUE	Description
APO	ENABLE* DISABLE	<p>Enables or disables automatic print orientation.</p> <ul style="list-style-type: none"> ENABLE—if the requested dimensions of the job fit on the paper, the page is printed either in portrait or landscape, whichever better fits the dimensions. If the requested dimensions do not fit on the paper, the default orientation for the tray (COR, PORT, LAND, or C-PORT) determines how the sheet is printed. DISABLE—the page prints using the default orientation for the tray (COR, PORT, LAND, or C-PORT). <p>Notes:</p> <ol style="list-style-type: none"> Values specified in the data stream override values set at the printer. The factory defaults (orientation set to COR and APO=ENABLE) give you the most flexibility. The requested dimensions are determined by the values of CPI, LINE SPACING, MPP, and MPL for the job. These values can be set in the data stream or on the Coax SCS Menu.
LPI	0 6* 8	Specifies a default lines per inch value for jobs received over the coax attachment. Valid values are 0, 6, and 8. The default is 6. 0 specifies either the value specified in the job or the PCL default value for the printer.
LINE SPACING	1* 2	Specifies single or double spacing: <ul style="list-style-type: none"> 1—single spacing 2—double spacing
CPI	nn	Specifies the default characters per inch, or pitch. nn can be 0, 10,12,15,16.7, 20, or 27. The default is 10. 0 specifies a proportional font (FGID 1452). Note that proportional fonts use proportional spacing, which may cause unexpected results (for example, tabular data may appear misaligned).
CASE	DUAL* MONO	Specifies the case of the printed text: <ul style="list-style-type: none"> DUAL—characters print in the case received MONO—all characters print in uppercase
MPL	nnn	Specifies the maximum page length (MPL) in lines per page. Valid values are 1 to 255. 66 is the default.
MPP	nnn	Specifies the maximum print position (MPP). Valid values are 1 to 255. 132 is the default.

COAX SCS MENU ITEM	VALUE	Description
CODE PAGE	nnn	<p>Specifies the code page to use. Code page 037 is the default.</p> <p>037 US, Canada, Netherlands, Portugal 273 Austrian/German 275 Brazil 277 Danish/Norwegian 278 Finnish/Swedish 280 Italian 281 Japanese 284 Spanish 285 UK English 286 Austrian/German (alternate) 287 Danish/Norwegian (alternate) 288 Finnish/Swedish (alternate) 289 Spanish 297 French 500 Belgium, Switzerland / International 871 Icelandic</p>
TBM	nnnn	<p>The top binding margin (TBM) determines the position of line 1 relative to the top edge of the printable area when printing in portrait or landscape orientation. TBM is measured in tenths of an inch, with a default of 0. It applies to all paper sources.</p>
LBM	nnnn	<p>The left binding margin (LBM) determines the position of column 1 relative to the left edge of the printable area when printing in portrait or landscape orientation. LBM is measured in tenths of an inch, with a default of 0. It applies to all paper sources.</p>

Twinax SCS Menu

Use the Twinax SCS Menu to define how the printer handles SCS data over the twinax attachment. The following table describes the settings you can change from the Twinax SCS Menu. An asterisk (*) next to a value in the table indicates the factory default. The Twinax SCS Menu appears only if you have the twinax attachment installed.

Notes:

1. To select a new value, press the **Continue/Enter** key when the value is displayed in the message display area. An asterisk (*) appears next to the value in the message display area, indicating that it is now active.
2. Values set in print jobs (either by the print application or the printer driver) override Twinax SCS Menu values set at the printer.
3. For more information about configuring the twinax attachment, see *IBM Network Printers: Twinax/Coax Configuration Guide*.
4. If you are unfamiliar with using the operator panel to work with menus, please read "Using the Operator Panel Keys" on page 10 and "Navigating Menus" on page 12 before continuing.

TWINAX SCS MENU ITEM	VALUE	Description
TRAY1 TRAY2 TRAY3 AUX	COR* PORT LAND C-PORT	<p>Specifies the default orientation for jobs printed from each tray listed on the menu. TRAY1 is the standard 250-sheet input tray. TRAY2 is the optional 500-sheet input tray if only one 500-sheet tray is installed, it is the upper 500-sheet tray if two 500-sheet trays are installed. TRAY3 is the lower 500-sheet tray when two 500-sheet trays are installed. AUX is the flip-down tray in the front of the printer. Each input can be assigned one of the following default orientations</p> <ul style="list-style-type: none"> • COR—computer output reduction: Printing in landscape with the logical page reduced to fit more data on the physical page. The printer reduces vertical spacing and uses a smaller font with less space between letters. • PORT—portrait: the page has normal, upright business letter orientation. • LAND—landscape: the page is wider than long. • C-PORT—compressed portrait: printing in portrait, but with spaces reduced between characters (horizontal compression) so that more text fits on a line. This allows more characters per line.
LPI	0 3 4 6* 8	Specifies a default lines per inch value. 0 specifies either the value specified in the job, or the PCL default value for the printer.

TWINAX SCS MENU ITEM	VALUE	Description																												
CPI	nn	Specifies the default characters per inch, or pitch. nn can be 5, 10, 12, 15, 17.1, 20, or 27. The default is 10.																												
CODE PAGE	nnn	<p>Specifies the default code page to use. The default value is code page 037.</p> <table border="0"> <tr><td>037</td><td>U.S.A. and Canada</td></tr> <tr><td>273</td><td>Austrian/German</td></tr> <tr><td>274</td><td>Belgium</td></tr> <tr><td>275</td><td>Brazil</td></tr> <tr><td>277</td><td>Danish/Norwegian</td></tr> <tr><td>278</td><td>Finnish/Swedish</td></tr> <tr><td>280</td><td>Italy</td></tr> <tr><td>281</td><td>Japanese (Latin)</td></tr> <tr><td>282</td><td>Portugal</td></tr> <tr><td>284</td><td>Spanish (Latin America)</td></tr> <tr><td>285</td><td>United Kingdom</td></tr> <tr><td>297</td><td>France</td></tr> <tr><td>500</td><td>Multinational (International #5)</td></tr> <tr><td>871</td><td>Iceland</td></tr> </table>	037	U.S.A. and Canada	273	Austrian/German	274	Belgium	275	Brazil	277	Danish/Norwegian	278	Finnish/Swedish	280	Italy	281	Japanese (Latin)	282	Portugal	284	Spanish (Latin America)	285	United Kingdom	297	France	500	Multinational (International #5)	871	Iceland
037	U.S.A. and Canada																													
273	Austrian/German																													
274	Belgium																													
275	Brazil																													
277	Danish/Norwegian																													
278	Finnish/Swedish																													
280	Italy																													
281	Japanese (Latin)																													
282	Portugal																													
284	Spanish (Latin America)																													
285	United Kingdom																													
297	France																													
500	Multinational (International #5)																													
871	Iceland																													
APO	ENABLE* DISABLE	<p>Enables or disables automatic print orientation.</p> <ul style="list-style-type: none"> • ENABLE—if the requested dimensions of the job fit on the paper, the page is printed either in portrait or landscape, whichever better fits the dimensions. If the requested dimensions do not fit on the paper, the default orientation for the tray (COR, PORT, LAND, or C-PORT) determines how the sheet is printed. • DISABLE—the page prints using the default orientation for the tray (COR, PORT, LAND, or C-PORT). <p>Notes:</p> <ol style="list-style-type: none"> 1. Values specified in the data stream override values set at the printer. 2. The factory defaults (orientation set to COR and APO=ENABLE) give you the most flexibility. 3. The requested dimensions are determined by the values of CPI, MPP, and MPL for the job. These values can be set in the data stream. CPI can be set on the Twinax SCS menu. The twinax default values for MPP and MPL cannot be set from a menu; they are 132 for MPP and 62 for MPL. 																												

Coax Setup Menu

Use the Coax Setup menu to configure the Coax attachment. The following table describes the settings you can change from the Coax Setup Menu. An asterisk (*) next to a value in the table indicates the factory default. The Coax Setup menu appears only if you have the coax attachment installed.

Notes:

1. To select a new value, press the **Continue/Enter** key when the value is displayed in the message display area. An asterisk (*) appears next to the value in the message display area, indicating that it is now active.
2. For more information about configuring the coax attachment, see *IBM Network Printers: Twinax/Coax Configuration Guide*.
3. If you are unfamiliar with using the operator panel to work with menus, please read "Using the Operator Panel Keys" on page 10 and "Navigating Menus" on page 12 before continuing.

COAX SETUP MENU ITEM	VALUE	Description
PORT TMEOUT	nnn	Specifies the number of seconds the printer waits for data before it determines there is no more data to receive for the job. The printer then checks other installed attachments, and switches to attachments with jobs waiting. nnn can be from 0 to 255. The default is 90 seconds.
IRQ TMEOUT	nn	Specifies when an IRQ (intervention required) timeout is sent. This tells the printer how long to wait for an intervention required condition to be corrected before notifying the host of the error. nn can be from 0 to 20 minutes. The default is 1 minute. 0 specifies to never send an IRQ timeout.
HLD TMEOUT	nn	Specifies the hold timeout value. This value tells the printer how long to wait if the printer is offline for an intervention required condition to be corrected. After this time elapses, the host is notified of the error. nn can be from 0 to 20 minutes. The default is 10 minutes. 0 specifies to never send a hold time out.
BUSY TMEOUT	nnn	Specifies the busy timeout value. This specifies the amount of time to wait (when the printer is connected to multiple ports) for control to be returned to the coax attachment before notifying the host. nnn can be from 0 to 999 minutes. The default is 20 minutes. 0 specifies to never send a busy timeout.

COAX SETUP MENU ITEM	VALUE	Description
EDGE-EDGE	OFF* ON	<p>Turns edge-to-edge printing on or off.</p> <ul style="list-style-type: none"> • OFF—the printer maintains a border of 4 mm on all four paper sides. • ON—The printer allows printing up to the physical page size. <p>Notes:</p> <ol style="list-style-type: none"> 1. To prevent toner from contaminating the printer, IBM recommends leaving EDGE-EDGE set to OFF; use ON only when necessary. 2. The Coax Setup Menu item EDGE-EDGE applies to SCS data only. To specify edge-to-edge printing for IPDS data, use the EDGE-EDGE item on the IPDS Menu.
EAB	DISABLE* ENABLE	Enables or disables the extended attribute buffer.
BUFFERSIZE	960 1920* 2560 3440 3564	Specifies the buffer size in bytes.
EARLY COMPL	ON* OFF	<p>Turns early print completion on or off for non-IPDS data sent over the coax attachment. To turn early print completion on or off for IPDS data, use the EARLY COMPL item on the IPDS Menu.</p> <ul style="list-style-type: none"> • ON—sends an “order complete” as soon as data is received. • OFF—waits until the print job is physically complete to send “order complete.”
PA1	none	<p>Selecting this value and pressing the Continue/Enter key sends a PA1 signal to the host.</p> <p>Note: This applies to SCS only; not DSC/DSE or IPDS.</p>
PA2	none	<p>Selecting this value and pressing the Continue/Enter key sends a PA2 signal to the host.</p> <p>Note: This applies to SCS only; not DSC/DSE or IPDS.</p>

Twinax Setup Menu

Use the Twinax Setup menu to configure the Twinax attachment. The following table describes the settings you can change from the Twinax Setup Menu. An asterisk (*) next to a value in the table indicates the factory default. The Twinax Setup Menu appears only if you have the twinax attachment installed.

Notes:

1. To select a new value, press the **Continue/Enter** key when the value is displayed in the message display area. An asterisk (*) appears next to the value in the message display area, indicating that it is now active.
Important! If you change SCS ADDR or IPDS ADDR, you must power off the printer, wait ten seconds, and then power on the printer for the new value to take effect.
2. For more information about configuring the twinax attachment, see *IBM Network Printers: Twinax/Coax Configuration Guide*.
3. If you are unfamiliar with using the operator panel to work with menus, please read "Using the Operator Panel Keys" on page 10 and "Navigating Menus" on page 12 before continuing.

TWINAX SETUP MENU ITEM	VALUE	Description
SCS ADDR	OFF* n	The twinax hardware address of the SCS port. n can be from 0 to 6. Notes: <ol style="list-style-type: none">1. SCS ADDR and IPDS ADDR cannot be set to the same value.2. If you change SCS ADDR or IPDS ADDR, you must power off the printer, wait ten seconds, and then power on the printer for the new value to take effect.3. When the optional IPDS SIMM is installed, each IBM Network Printer can act as two separate printers on the same twinax port. (The printer cannot be attached to two different twinax systems using the same twinax card.) One "printer" prints SCS data to one address (SCS ADDR), and the other prints IPDS to another address (IPDS ADDR).

TWINAX SETUP MENU ITEM	VALUE	Description
IPDS ADDR	OFF* n	<p>The twinax hardware address of the IPDS port. n can be from 0 to 6.</p> <p>Notes:</p> <ol style="list-style-type: none"> 1. SCS ADDR and IPDS ADDR cannot be set to the same value. 2. If you change SCS ADDR or IPDS ADDR, you must power off the printer, wait ten seconds, and then power on the printer for the new value to take effect. 3. When the optional IPDS SIMM is installed, each IBM Network Printer can act as two separate printers on the same twinax port. (The printer cannot be attached to two different twinax systems using the same twinax card.) One "printer" prints SCS data to one address (SCS ADDR), and the other prints IPDS to another address (IPDS ADDR).
EDGE-EDGE	OFF* ON	<p>Turns edge-to-edge printing on or off.</p> <ul style="list-style-type: none"> • OFF—the printer maintains a no-print border of 4 mm on all four paper sides. • ON—The printer allows printing up to the physical page size. <p>Notes:</p> <ol style="list-style-type: none"> 1. To avoid toner contaminating the printer, IBM recommends leaving EDGE-EDGE set to OFF; use ON only when necessary. 2. The Twinax Setup Menu item EDGE-EDGE applies to SCS data only. To specify edge-to-edge printing for IPDS data, use the EDGE-EDGE item on the IPDS Menu.
BUFFERSIZE	1024* 256	<p>Specifies the IPDS buffer size in bytes. The SCS buffer size is always 256.</p>
PORT TMEOUT	nnn	<p>Specifies the number of seconds the printer waits for data before it determines there is no more data to receive for the job. The printer then checks other installed attachments, and switches to attachments with jobs waiting. Valid values are 5 to 300. The default is 90 seconds.</p>

Coax DSC/DSE Menu

Use the Coax DSC/DSE Menu to define how the printer handles DSC/DSE communications over the Coax attachment. The following table describes the settings you can change from the Coax DSC/DSE Menu. The options you specify apply only to DSC/DSE mode. An asterisk (*) next to a value in the table indicates the factory default. The Coax DSC/DSE Menu appears only if you have the coax attachment installed.

Notes:

1. To select a new value, press the **Continue/Enter** key when the value is displayed in the message display area. An asterisk (*) appears next to the value in the message display area, indicating that it is now active.
2. For more information about configuring the coax attachment, see *IBM Network Printers: Twinax/Coax Configuration Guide*.
3. If you are unfamiliar with using the operator panel to work with menus, please read "Using the Operator Panel Keys" on page 10 and "Navigating Menus" on page 12 before continuing.

COAX DSC/DSE MENU ITEM	VALUE	Description
PRINT IMAGE	ON* OFF	Selects printing options in non-SCS mode. <ul style="list-style-type: none">• ON<ul style="list-style-type: none">– True Screen image in Local Copy– True Screen image in Non-SCS print– Unformatted print in Local Copy– Unformatted print in Non-SCS print• OFF<ul style="list-style-type: none">– Null line suppression in Local Copy– Null line suppression in Non-SCS print– Formatted print in Local Copy– Formatted print in Non-SCS print
CR AT MPP+1	ON* OFF	Sets a carriage return relative to the maximum print position (MPP). <ul style="list-style-type: none">• ON—a new line occurs when the carriage return occurs at MPP+1. The next print position is at the first print position of the new line (current line + 1, column 1).• OFF—no new line occurs when the carriage return occurs at MPP+1. The next print position is at the first print position of the current line (current line, column 1).

COAX DSC/DSE MENU ITEM	VALUE	Description
NL AT MPP+1	ON* OFF	<p>Forces a new line at MPP+1.</p> <ul style="list-style-type: none"> • ON—an additional new line occurs at MPP+1, followed by the carriage return. The next print position is at the first print position of the new line (current line + 2, column 1). • OFF—no additional new line when the new line occurs at MPP+1. The next print position is at the first print position of the next line (current line + 1, column 1).
FF DATA	ON* OFF	<p>Forces the printer to eject the current page.</p> <ul style="list-style-type: none"> • ON—when a Form Feed command is encountered, the current page is ejected and the form is indexed to the first line of the next page. The next print position is at the first print position of the first line of the next page (next form, line 1, column 1). • OFF—when a Form Feed command is encountered, the current page is ejected and the form is indexed to the first line of the next page and spaced one position. The next print position is at the first print position plus 1 of the first line of the next page (next form, line 1, column 2).
FF LAST	ON* OFF	<p>Determines where to position the next character when the Form Feed command occurs at the end of the print buffer.</p> <ul style="list-style-type: none"> • ON—an automatic new line occurs after the print order is completed (next form, line 2, column 1). • OFF—suppress automatic new line after the print order is completed (next form, line 1, column 1).
FF VALID	OFF* ON	<p>Determines when a form feed command is valid.</p> <ul style="list-style-type: none"> • ON—a Form Feed command occurs whenever it is encountered. • OFF—a Form Feed command occurs only if it appears at the first print position in a line, or at MPP+1. Treats a form feed at other locations as blanks.
AUTO FUNCTION	OFF* ON	<p>Selects whether the next print position is on a new line or a new page.</p> <ul style="list-style-type: none"> • OFF—a new line is executed automatically at the end the print order (when printing of a buffer is completed) unless a form feed (FF), new line (NL), or carriage return (CR) was the last character in the print order. • ON—a form feed is executed automatically at the end of the print order (when printing of a buffer is completed) unless a form feed (FF) is the last character in the print order.

IPDS Menu

The following table describes the settings you can change from the IPDS Menu. An asterisk (*) next to a value in the table indicates the factory default. The IPDS Menu appears only if you have the IPDS SIMM installed.

Notes:

1. To select a new value, press the **Continue/Enter** key when the value is displayed in the message display area. An asterisk (*) appears next to the value in the message display area, indicating that it is now active.
2. Values specified in IPDS print jobs override IPDS Menu values set at the printer.
3. If you are unfamiliar with using the operator panel to work with menus, please read “Using the Operator Panel Keys” on page 10 and “Navigating Menus” on page 12 before continuing.

IPDS MENU ITEM	VALUE	Description
PAGEPROT	AUTO* ON	Sets page protection: <ul style="list-style-type: none">• AUTO—the printer uses the minimum amount of memory necessary to print a page.• ON—the printer reserves enough memory to process an entire page without compression before it prints the page. This can help in the rare case where the printer compression scheme causes a loss of quality in complex graphics. This setting is available only when the printer has enough memory. See “Memory Requirements” on page 3 for more information.

IPDS MENU ITEM	VALUE	Description
DEF CD PAG	nnnn	<p>Specifies the default code page. The default value is code page 037.</p> <ul style="list-style-type: none"> 037 US, Canada, Netherlands, Portugal 038 US English ASCII 260 Canadian French 273 Austrian/German 274 Belgium 276 Canadian French 277 Danish/Norwegian 278 Finnish/Swedish 280 Italian 281 Japanese 284 Spanish 285 UK English 286 Austrian/German (alternate) 287 Danish/Norwegian (Alternate) 288 Finnish/Swedish (Alternate) 290 Japanese/Katakana 297 French 420 Arabic 423 Greek 424 Hebrew 500 Belgium, Switzerland / International 870 Latin 2 Multilingual 871 Icelandic 875 Greek 880 Cyrillic 892 OCR - A 893 OCR - B 905 Turkish 1025 Cyrillic Multilingual 1026 Turkish
EMULATION	4028* 4317	<p>Specifies the printer to emulate. Select 4317 only if you have the appropriate level of PSF software installed. (Consult with your system administrator.)</p>
DEFAULT FGID	nnnn	<p>Specifies the default FGID (Font Typeface Global Identifier), which identifies the default resident font the printer uses. The default value is FGID 416, which specifies Courier 10 point as the default resident font.</p> <p>To display the list of fonts and FGIDs the printer supports, print out a list of IPDS resident fonts (see "Printing a List of IPDS Resident Fonts" on page 17).</p>
DEF CPI	nn.n	<p>Selects characters-per-inch (pitch) for the default font. Valid values are 5.0 to 30.0 in tenths of an inch. The default value is 10.0.</p>

IPDS MENU ITEM	VALUE	Description
VPA CHK	ON* OFF	<p>Turns valid printable area checking on or off.</p> <ul style="list-style-type: none"> • ON—the printer checks for pels that fall outside the intersection of the logical and physical pages. If pels fall outside the area, the printer reports an error to the host if the IPDS Exception Handling Control command setting requires error reporting. • OFF—The printer does not report pels outside the valid printable area.
X-OFFSET	nnn	<p>Sets the print offset in the X (horizontal) direction. nnn can be from -999 to 999. The default setting is 0 pels. Positive values move the starting point for printing to the right of the physical point of origin. Negative values move the starting point for printing to the left. The physical point of origin is towards the top left corner of a portrait page. If you rotate the page, the physical point of origin rotates as well.</p> <p>Note: The X-OFFSET and Y-OFFSET options are intended to allow older line printer print jobs to fit on a page where edge-to-edge printing is not possible. Using X-OFFSET and Y-OFFSET is NOT recommended when generating new applications, especially duplex applications.</p>
Y-OFFSET	nnn	<p>Sets the print offset in the Y (vertical) direction. nnn can be from -999 to 999. The default setting is 0 pels. Positive values move the starting point for printing down from the physical point of origin. Negative values move the starting point for printing up. The physical point of origin is towards the top left corner of a portrait page. If you rotate the page, the physical point of origin rotates as well.</p> <p>Note: The X-OFFSET and Y-OFFSET options are intended to allow older line printer print jobs to fit on a page where edge-to-edge printing is not possible. Using X-OFFSET and Y-OFFSET is NOT recommended when generating new applications, especially duplex applications.</p>

IPDS MENU ITEM	VALUE	Description
PAGE	WHOLE* PRINT COMP1 COMP2	<p>Determines how data is positioned on the page.</p> <ul style="list-style-type: none"> • WHOLE—IPDS whole page (default). The printer does not move or compress the page. This is the preferred method; all page positioning and formatting is done at the application level on the host. The PRINT, COMP1, and COMP2 options may alter the appearance of the page, or may not be compatible to predecessor products (for example, 3116, 3916), especially when combined with duplex and other IPDS MENU page format adjustments such as X-OFFSET and Y-OFFSET. PRINT, COMP1, and COMP2 are included to allow older line printer jobs to fit on a page where edge-to-edge printing was not possible; they are NOT recommended for use in generating new applications. • PRINT—IPDS print page. If the page origin falls within the unprintable area, the origin of the page is moved to the inside edge of the nearest unprintable area border. If the origin violates the unprintable area on two edges, it is moved to the nearest inside corner of the unprintable area. If the origin violates only one edge unprintable area, then the origin is adjusted to get out of only that area. If a location adjustment is made, the printed page shifts in the direction of the adjustment. There is no compression, so the opposite-edge data may be pushed off the page. Note: PRINT requires EDGE-EDGE set OFF to work. Any data placed in this unprintable area is lost. Also, PRINT will not work on envelopes or media overlays (overlays that are part of the base page, not the overlays included in the variable print data). • COMP1—COMP1 format uses PRINT page as a base, and then compresses the spacing between text lines generated by the IPDS Begin Line command. Its primary purpose is to compress Begin Line text data into a page with unprintable borders. • COMP2—COMP2 format uses PRINT page as a base, and then adds compression IPDS Begin Line command (see COMP1) and of the following vertical text positioning commands: Absolute Move Baseline, Relative Move Baseline, Draw B Axis Rule, Draw I Axis Rule. <p>Note: Alignment problems can occur if you select COMP1 or COMP2 and you print jobs that mix text with images, graphics, or bar codes. Problems arise when text positioning commands are used to move across text or into non-text (image, graphic, or bar-code) areas. Both COMP1 and COMP2 reduce the line spacing of text only and have no effect on non-text data. To minimize this problem, select COMP1, because Begin Line commands are not normally used to move across or into non-text areas. If, however, the application you want to compress does not use Begin Line commands, you should select COMP2.</p>

IPDS MENU ITEM	VALUE	Description
EDGE-EDGE	OFF* ON	<p>Turns edge-to-edge printing on or off.</p> <ul style="list-style-type: none"> • OFF—the printer maintains a no-print border of 4 mm on all four paper sides. • ON—The printer allows printing up to the physical page size. <p>Notes:</p> <ol style="list-style-type: none"> 1. To prevent toner from contaminating the printer, IBM recommends leaving EDGE-EDGE set to OFF; use ON only when necessary. 2. The IPDS Menu item EDGE-EDGE applies to IPDS data only. To specify edge-to-edge printing for non-IPDS data sent over the coax attachment, use the EDGE-EDGE item on the Coax Setup Menu. To specify edge-to-edge printing for non-IPDS data sent over the twinax attachment, use the EDGE-EDGE item on the Twinax Setup Menu.
FONT SUB	OFF* ON	<p>Turns font substitution on or off.</p> <ul style="list-style-type: none"> • OFF—if a job requests a font that is not loaded on the printer, the port generates an IPDS NACK message and the host holds the job. • ON—if a job requests a font that is not loaded on the printer, the printer attempts to substitute another font.
IPDS PORT	COAX* TX TRING ETHER	<p>Specifies the attachment you use for IPDS jobs.</p> <p>Note: You can print IPDS from more than one port; setting this item, therefore, does not restrict you from printing from multiple ports. Also, this item may not appear on some printers.</p>
EARLY COMPL	OFF* ON	<p>Turns early print completion on or off for IPDS jobs.</p> <ul style="list-style-type: none"> • OFF—the printer waits until the job is physically complete to signal the host that the job is complete. • ON—the printer signals the host that the job is complete as soon as the IPDS data is formatted. <p>Setting EARLY COMPL=ON may improve print performance, but may also degrade recovery and cause lost data for some printing problems, such as jams.</p>

Machine Information Menu

Use the Machine Info Menu to display information about printer supply usage. The following table describes the functions you can perform from the Machine Info Menu.

Note: To perform the action associated with the menu item you select, press the **Continue/Enter** key. If you are unfamiliar with using the operator panel to work with menus, please read “Using the Operator Panel Keys” on page 10 and “Navigating Menus” on page 12 before continuing.

MACHINE INFO MENU ITEM	Description
PAGE COUNT	Displays the number of pages the printer has printed.
ERROR LOG	Displays the error log. Use the Value key to scroll through the list.
TONER CTR	Displays the toner cartridge counter. Note: IBM recommends resetting this counter whenever you change toner cartridges. To reset the counter: <ol style="list-style-type: none">1. Simultaneously press the Shift and Value keys.2. Press the Continue/Enter key. The new value will not be displayed until the next time you power off and then power on the printer.
FUSER CTR	Displays the fuser counter. Note: IBM recommends resetting this counter whenever you change the fuser kit. To reset the counter: <ol style="list-style-type: none">1. Simultaneously press the Shift and Value keys.2. Press the Continue/Enter key. The new value will not be displayed until the next time you power off and then power on the printer.

Language Menu

Use the Language Menu to select the language that the printer uses to display messages and menus on the operator panel. English is the factory default.

Notes:

1. To select a language, press the **Continue/Enter** key when the language value is displayed in the message display area. An asterisk (*) appears next to the new value, indicating that it is now active.
2. If you are unfamiliar with using the operator panel to work with menus, please read "Using the Operator Panel Keys" on page 10 and "Navigating Menus" on page 12 before continuing.

ITEM	Description
ENGLISH* DANISH DUTCH FINNISH FRENCH GERMAN ITALIAN NORWEGIAN PORTUGUESE SPANISH SWEDISH KATAKANA	Selects the language in which the printer displays operator panel messages and menus. Note: On the actual operator panel, the name of each language may be spelled using its native spelling. Also, the order of the languages may be different than the order displayed here.

Chapter 6. Maintaining the Printer

This chapter describes how to:

- Replace the toner cartridge
- Replace the usage kit (fuser unit and transfer roller)
- Clean the outside covers of the printer

Note: Routine care and maintenance of the printer is the customer's responsibility.

Replacing Supplies

It is the customer's responsibility to order supplies for the Network Printer 17. To ensure best print quality and performance, use IBM supplies.

Printing supplies can be ordered through your IBM authorized printer or printer supplies reseller. If you have no reseller, you can call 1-888-IBM-PRINT (1-888-426-7746) in the U.S. or Canada to ask for an authorized dealer or to order from IBM Printer Supplies.

In other countries, contact your point of purchase for information about where to order supplies.

In Europe, you can call IBM Supplies Fulfillment Operations at 31-43-350 2756 or at the following numbers:

- Denmark: 80015534
- Finland: 08001-13110
- France: 05-905871
- Germany: 0130 818005
- Italy: 1-678 78349
- Norway: 800-11389
- Sweden: 020-794270
- United Kingdom: 0800-968679

Changing the Toner Cartridge

Important

The part number for a replacement toner cartridge is 63H2401.

A toner cartridge can print approximately 10,000 pages of letter-size paper, containing text or graphics that cover 5% of the page. Depending on the type of printing you do, you can obtain double the page yield if you use the TonerMiser feature. For example, using the TonerMiser feature and a density setting of 3, you can expect an average cartridge life of 20,000 images at 5% coverage. To use the TonerMiser feature, you can set the Config Menu QUALITY setting to ECONO, or select toner saver print quality mode using your printer driver. (Note that the driver setting will override the menu

setting.) The page-per-cartridge average goes down if you routinely print text or graphics that cover more than 5% of the page.

When the toner cartridge is low or empty, the 02 TONER LOW message appears in the display.

To display the number of pages printed using the current toner cartridge, select TONER CTR on the Machine Info Menu (see “Machine Information Menu” on page 109). Note that the counter is accurate only if it was reset when the cartridge was installed.

Use the following procedure to replace the toner cartridge.

1. Remove the optional envelope feeder (if installed). See “Removing the Envelope Feeder” on page 177 for instructions.
2. Remove all paper from the auxiliary tray, and close it.

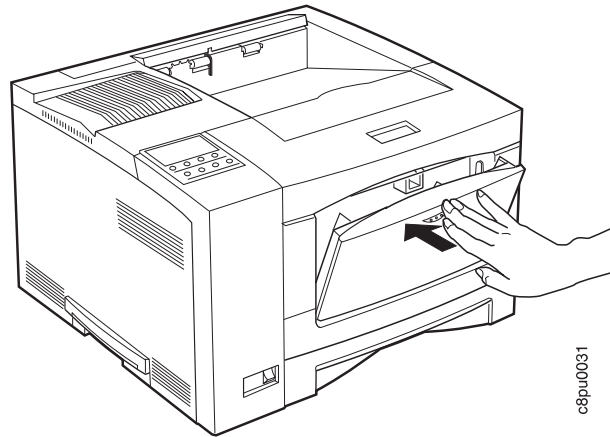

3. Press the release button and open the front cover.

Attention: Do not touch any of the internal parts.

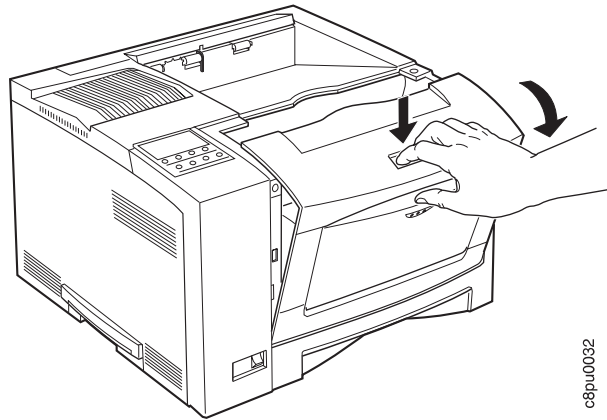

4. Remove the used toner cartridge.

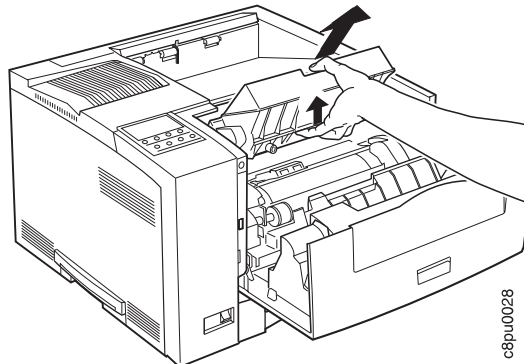

Note: Keep the toner cartridge level to avoid spilling toner. If you use the IBM Printer Supplies Return Program, you can use the box containing the new toner to return the old toner cartridge to IBM for recycling. Follow the instructions on the brochure included with the new toner cartridge.

5. Remove the new toner cartridge from its foil wrapper.

Attention: Do not expose the cartridge to direct sunlight. Do not leave the cartridge exposed outside the printer or the foil wrapper for more than five minutes.

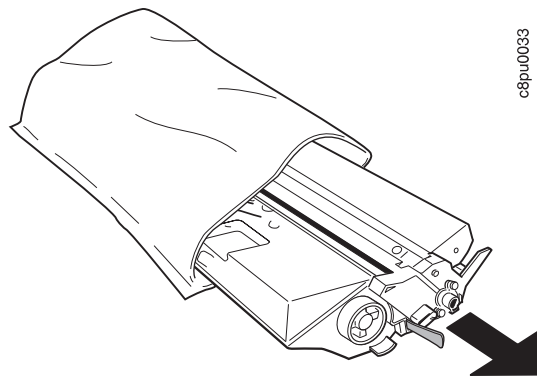

6. Grip the cartridge at each end and gently rock it from side to side to evenly distribute the toner.

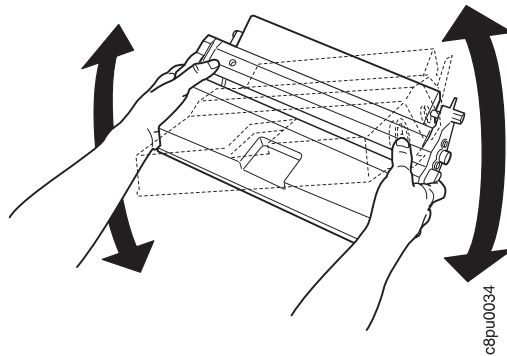

7. Place the cartridge on a flat surface and locate the yellow tape at the end of the cartridge. Pull the end of the tape straight out to remove the toner seal.

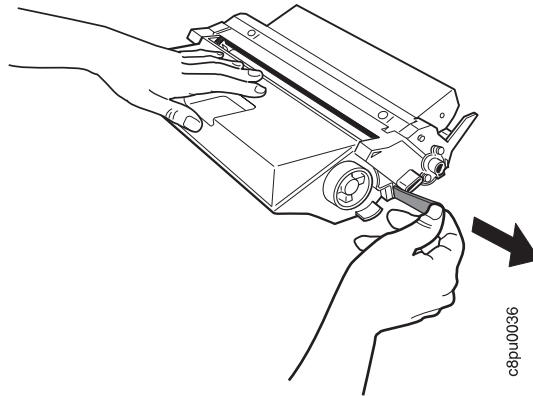

8. Grip the toner cartridge as shown.

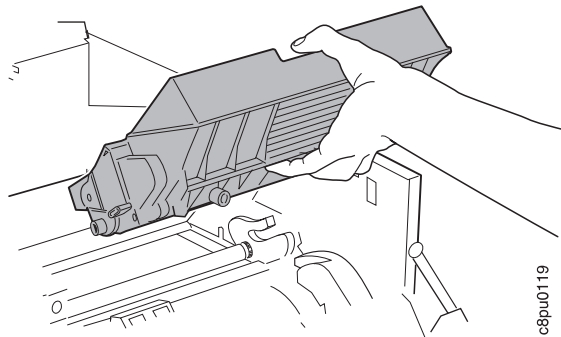

- Slide the cartridge into the printer guide channels. To make sure the toner cartridge is secure, gently press both ends of the cartridge until the cartridge stops.

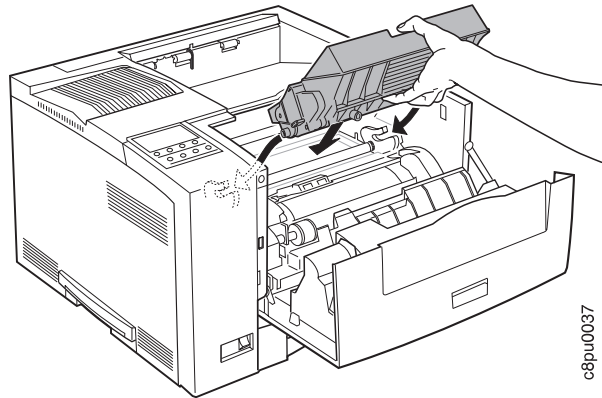

- Close the front cover.
- Reset the toner counter. See "Machine Information Menu" on page 109.
- If you removed the optional envelope feeder, reinstall it. See "Installing the Envelope Feeder" on page 174 for instructions.

Changing the Usage Kit

The usable life of the usage kit depends on the type of paper you use and the type of output you print.

The part numbers for replacement usage kits are:

- Model 001 (120 volt): 63H2324
- Model 002 (230 volt): 63H2325

Removing the Used Fuser Unit

Use the following procedure to remove a used fuser unit:

1. Power off the printer.
2. Unplug the printer power cord from the wall outlet.
3. Remove the power cord from the back of the printer.

CAUTION:

Do not touch the fuser (labeled) inside the printer. It can be extremely hot. Always wait at least 40 minutes for the fuser to cool down.

4. Press the release lever and open the back cover.

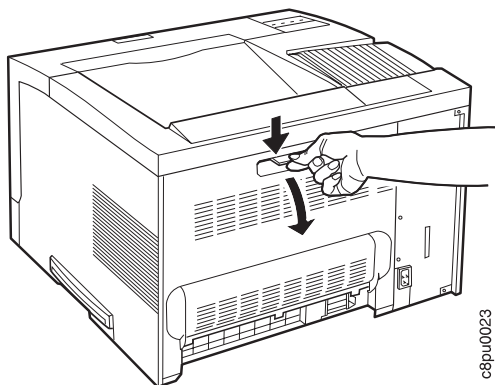

CAUTION:

Be careful when removing the duplex unit. The small motor at the end of the duplex unit may be hot.

5. Remove the duplex unit (if installed). Press in on the two green lock buttons located on both ends of the duplex unit and slide the unit out of the printer.

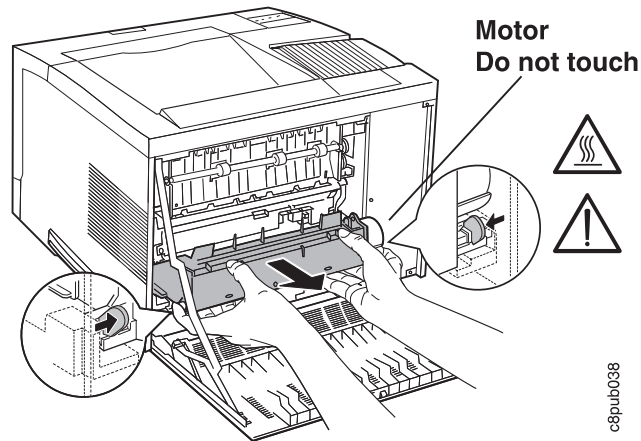

6. Remove the two slotted thumbscrews that are located at both ends of the fuser. You may need to use a coin or a screwdriver to loosen the screws.

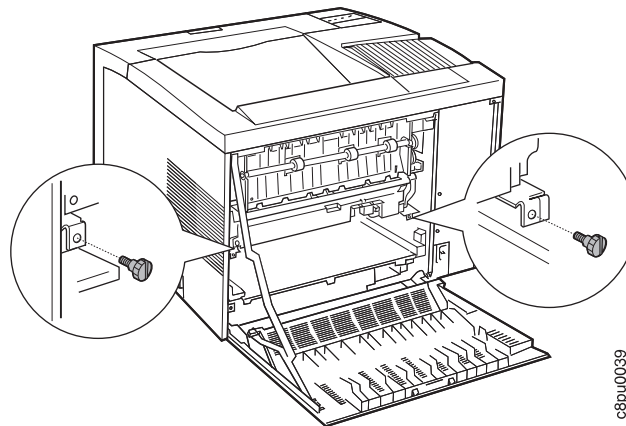

7. Hold on to the two orange/beige handles and slide the fuser out from the printer.

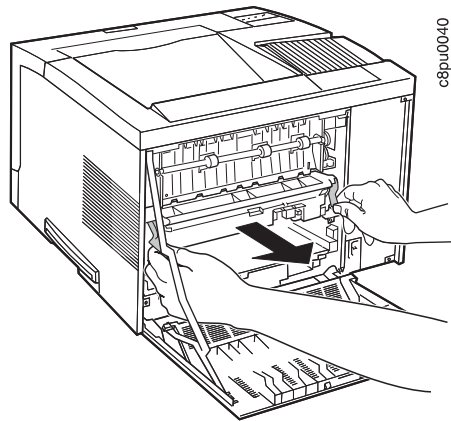

8. Dispose of the old fuser as nonflammable material in accordance with your local standards.

Installing a New Fuser Unit

1. Unpack a new fuser unit.
2. Position the fuser unit as shown and slide the fuser unit into the printer.

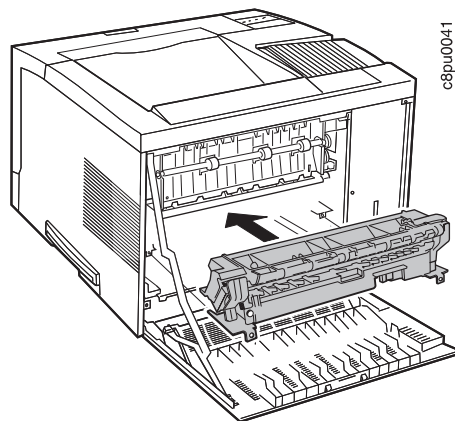

Note: If the fuser unit is difficult to insert, use extra pressure on the right-hand side while sliding it into the printer.

3. Make sure the two screw holes on the fuser unit line up with the screw holes on the printer.
4. Reinstall the two slotted thumbscrews.
5. Reinstall the duplex unit, if present.
6. Close the back cover.
7. IBM recommends that you also install a transfer roller now. See step 5 on page 122 in Removing the Used Transfer Roller.
8. Plug the power cord into printer and the wall outlet.
9. Switch the printer power on.
10. Reset the fuser counter. Use the Machine Info Menu to reset FUSER CTR (see "Machine Information Menu" on page 109).
11. After the printer warms up, the READY message displays on the operator panel.

Note: If any message other than READY is displayed, refer to Appendix B, "Printer Messages" on page 191.

Replacing the Transfer Roller

The transfer roller is the black rubber roller that is located inside the printer, just below the toner cartridge. The transfer roller should be replaced at the same time you replace the fuser.

Removing the Used Transfer Roller

1. Power off the printer.
2. Unplug the printer power cord from the wall outlet.
3. Remove the power cord from the back of the printer.
4. Press the release button and open the front cover.

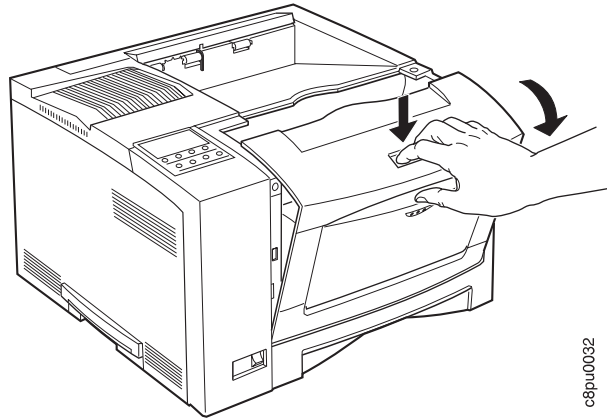

c8pu0032

5. Remove the toner cartridge. If the optional envelope feeder is installed, you must remove it before you remove the toner cartridge. See "Removing the Envelope Feeder" on page 177 for instructions.

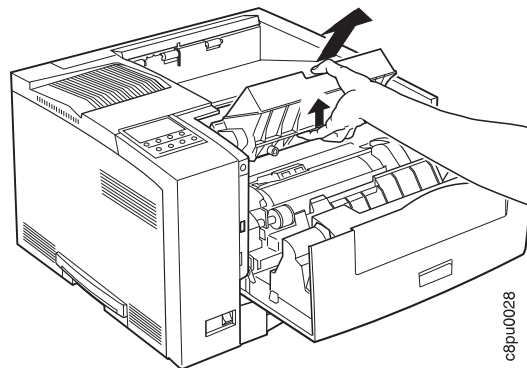

6. Take the transfer roller removal tool that is provided with the new transfer roller and insert it under the orange/beige flange that is located at the left end of the transfer roller.

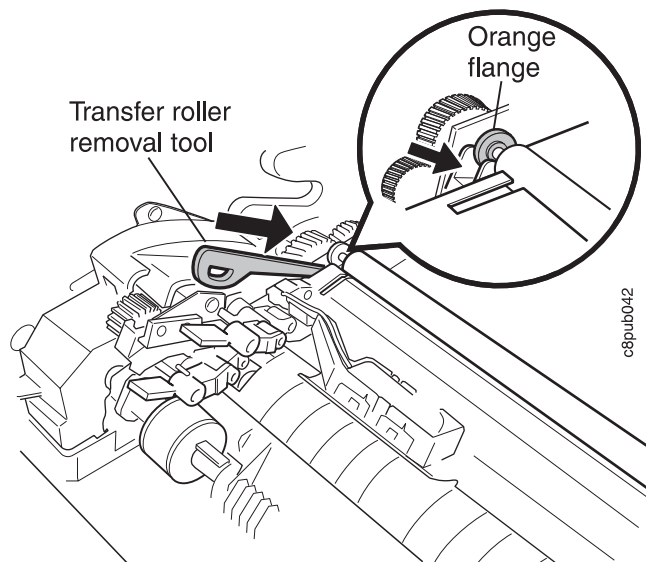

7. Push in on the tool until the left end of the old transfer roller pops out of the notch.
8. Use the tool in the same way to free the right end of the old transfer roller.

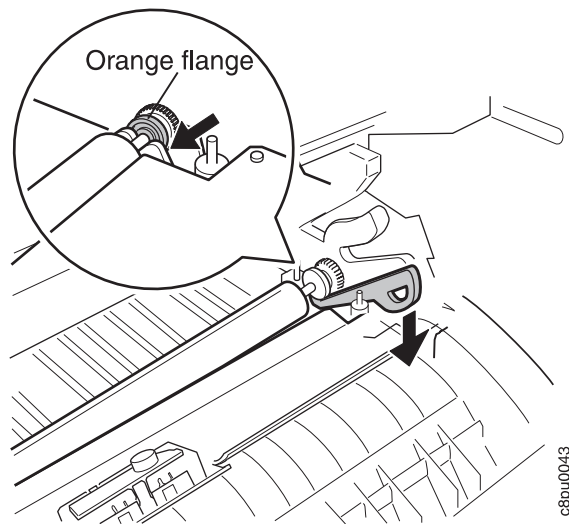

9. Hold on to the ends of the transfer roller and remove it from the printer.

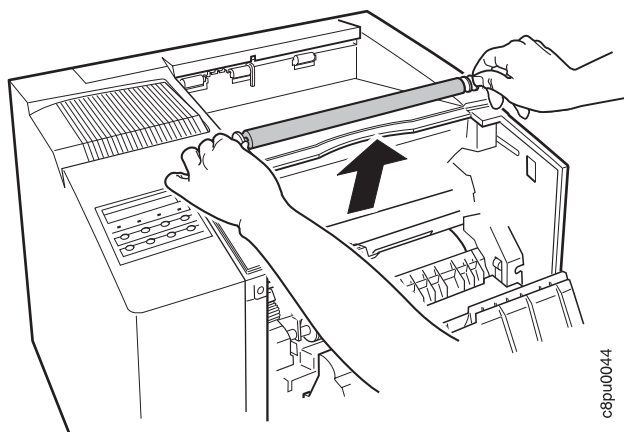

10. Dispose of the old transfer roller as nonflammable material in accordance with your local regulations.

Installing a New Transfer Roller

1. Hold the new transfer roller so the arrow on the orange wrapper points toward the front of the printer.

Attention: Do not remove the orange wrapper until the transfer roller has been installed in the printer.

2. Position the transfer roller so the ends are over the notches in the frame and the gear end of the shaft is on the right side, as shown in the illustration.

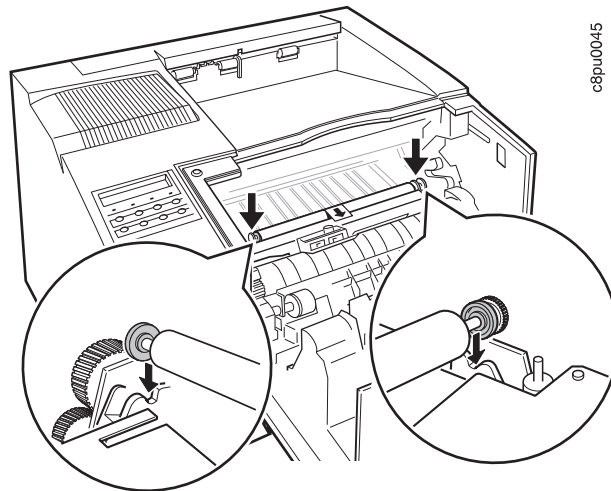

3. Push down on both ends of the transfer roller until they snap securely into place.

Attention: Do not touch the transfer roller with your hands because skin oils will degrade the transfer roll life.

4. Remove the orange wrapper by pulling the center tab in the direction of the arrow.

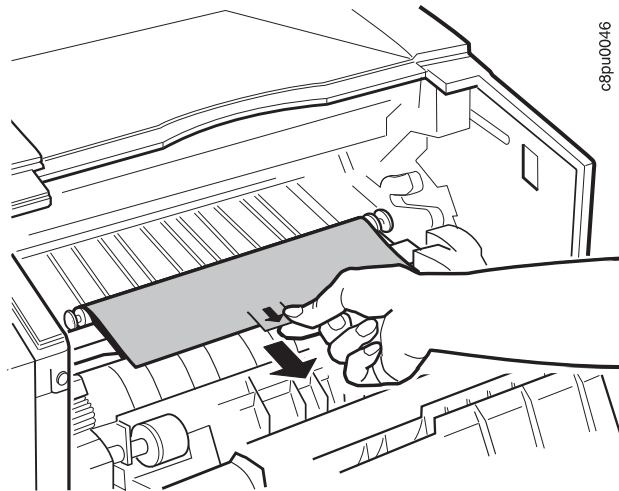

5. Discard the orange wrapper.
6. Reinstall the toner cartridge. If you removed the optional envelope feeder, reinstall it. See “Installing the Envelope Feeder” on page 174 for instructions.
7. Close the front cover.
8. Plug the power cord into printer and the wall outlet.
9. Switch the printer power on.
10. Reset the fuser counter (if this was not done when you installed a new fuser unit). Use the Machine Info Menu to reset FUSER CTR (see “Machine Information Menu” on page 109).

Cleaning the Printer

Use a soft, lint-free cloth to clean the outside covers of the printer.

Attention: Do not use abrasive cleaners on the printer covers. Do not use detergent solutions or other liquids on electronic components. Do not use cleaners that contain ammonia.

Chapter 7. Installing Printer Options

This chapter describes how to install and remove the following options:

- The SIMM and hard drive (see page 128)
- The Network Interface Card (see page 135)
- The duplex unit (see page 140)
- The 500-sheet paper tray (see page 144)
- The 500-sheet offset paper output bin option (see page 161)
- The 10-bin mailbox (see page 167)
- The envelope feeder (see page 174)

Important

To verify that an option is installed correctly, print the configuration page. See "Printing the Printer Configuration Page" on page 13. Also, make sure you update your printer driver to indicate the new feature is installed.

Handling Static Sensitive Devices

When you handle options and other computer components, take these precautions:

- Limit your movement. Movement can cause static electricity to build up around you.
- Always handle components carefully. Handle adapters and memory-module kits by the edges. Never touch any exposed circuitry.
- When you are installing a new option, touch the static-protective package containing the option to the mounting bracket on the controller card for at least two seconds. This reduces static electricity from the package and from your body.
- When possible, remove the option and install it directly in the controller without setting the option down. When this is not possible, place the static-protective package that the option came in on a smooth, level surface and place the option on it.
- Do not place the option on the printer cover or other metal surface.

The SIMM and Hard Drive Options

Optional SIMMs include:

- Dynamic random access memory (DRAM) SIMMs: 4MB, 8MB, 16MB, or 32MB
- Flash memory SIMMs: 2MB or 4MB
- Data stream SIMMs:
 - Adobe PostScript Level 2
 - Intelligent Printer Data Stream (IPDS)

To install any SIMM or the optional 810MB hard drive, you must remove the controller card (see “Removing the Controller Card” on page 129).

Removing the Controller Card

Use the following procedure to remove the controller card:

Attention: Do not switch the power off if the printer is printing a page. This action jams the printer.

CAUTION:
Failure to turn off the printer before working with its internal components can result in electric shock.

1. Switch the printer power off.
2. Unplug the printer from the wall outlet.
3. Remove the power cord from the back of the printer.
4. Loosen the thumbscrews located on the controller card at the back of the printer.
Remove the controller card.

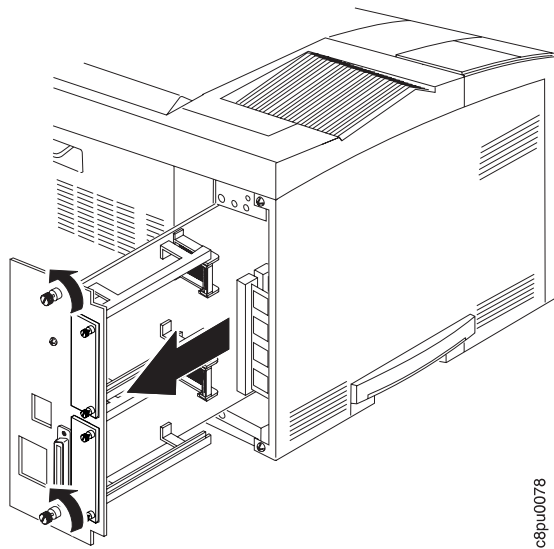

Note: The illustration shows a controller card with no network interface cards installed. You do not need to remove network interface cards before removing the controller card.

5. Lay the controller card on a flat surface.
6. To install a SIMM, see “Installing a SIMM” on page 130. To install a hard drive, see “Installing a Hard Drive” on page 132.

Installing a SIMM

Important

Follow the instructions for handling static-sensitive devices described on page 127.

Attention: Printer power should be off before performing this procedure.

Use the following procedure to install a SIMM:

1. The controller card must be removed before installing a SIMM. Follow the procedure “Removing the Controller Card” on page 129.
2. Locate the correct socket group for the type of SIMM you are installing. There are two socket groups: one contains two sockets, the other contains four sockets. The DRAM SIMMs (memory) must be installed in one of the sockets in the socket group of two. The data stream SIMMs and the flash memory SIMMs must be installed in one of the sockets in the socket group of four.

SIMMs should be loaded from the left to the right but the position of the SIMM within the group of sockets does not matter.

Note: Early printers may have the PCL5e SIMM already installed in socket 0. If the SIMM is not installed, PCL5e data stream support is integrated into the controller card.

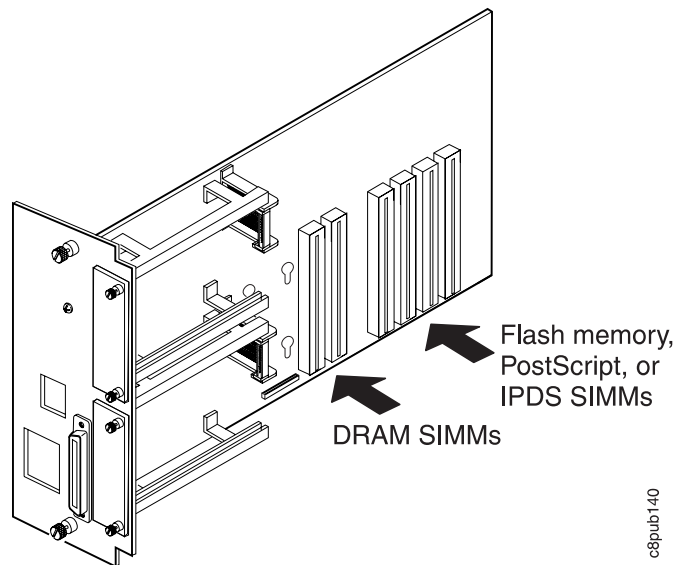

3. Hold the SIMM with the notch facing up and to the left. Insert the SIMM at a 45 degree angle and move it into position in the socket. Using your thumbs, press with even pressure on both ends of the SIMM until the SIMM is firmly seated in the socket.

Make sure the clips on either end of the socket snap into place to hold the SIMM. If necessary, use your thumbs to move the clips upright into the grooves to lock the SIMM in place.

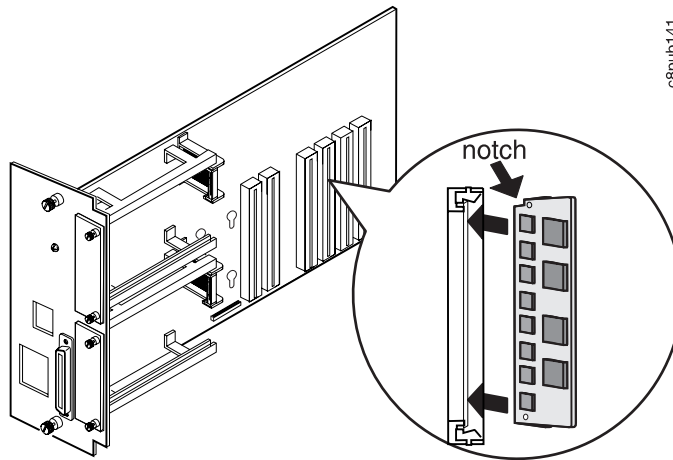

c8pub141

4. Verify that the SIMM is correctly installed in the socket by looking at its position from the sides of the controller card.
5. Reinstall the controller card. Follow the procedure “Reinstalling the Controller Card” on page 134.

Installing a Hard Drive

Important

Follow the instructions for handling static-sensitive devices described on page 135.

Attention: Printer power should be off before performing this procedure.

Use the following procedure to install a hard drive:

1. The controller card must be removed before installing the hard drive. Follow the procedure "Removing the Controller Card" on page 129.
2. Unpack the hard drive.
3. Position the hard drive with the four screws facing the four matching holes on the controller card.

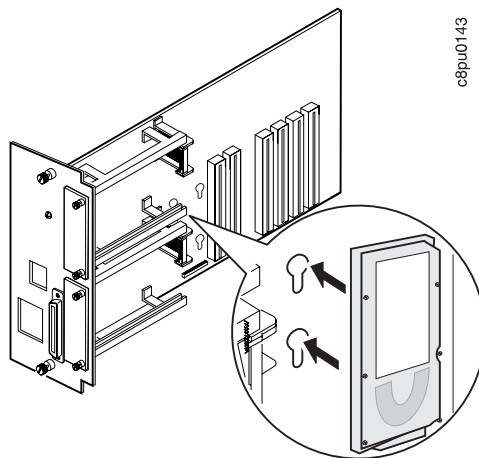

4. Push the hard drive firmly into the card and slide it down toward the connector at the bottom of the controller card. The pins on the hard drive should be firmly seated in the connector slots.

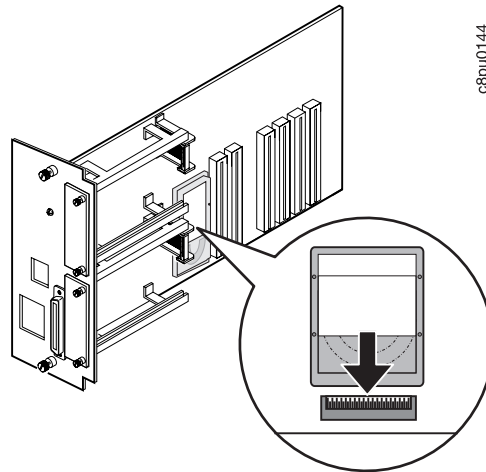

5. Reinstall the controller card. Follow the procedure “Reinstalling the Controller Card” on page 134.

Reinstalling the Controller Card

Use the following procedure to reinstall the controller card:

1. Place the controller card into the guide channels at the top and bottom of the back opening. Slide the controller card back into the printer. Note that the latches click when the controller card is in the correct position.
2. Tighten the thumbscrews at the top and bottom of the controller card mounting bracket.

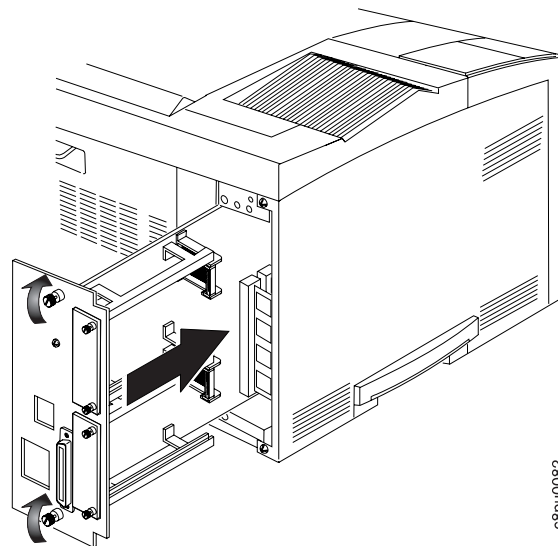

c8pu0082

3. Connect the power cord to the back of the printer.
4. Connect the other end of the power cord to a grounded AC outlet.
5. Switch the printer power on.
6. After the printer warms up, the READY message displays on the operator panel.
Note: If the message display area shows solid rectangles, reseal the card.
7. To confirm that you have correctly installed a memory SIMM, hard drive, data stream SIMM, or any combination, print a configuration page. The report will list the features if they have been correctly installed. See "Printing the Printer Configuration Page" on page 13.
Note: If the options do not appear for the SIMM or hard drive, remove the controller card, make sure that the SIMM or hard drive is correctly seated, and reinstall the controller card.
8. Make sure you update your printer driver to indicate the new DRAM SIMM, PostScript SIMM, IPDS SIMM, Flash Memory SIMM, or hard drive is installed.

The Network Interface Card

The Network Printer 17 attaches to networks and other system configurations through these optional cards:

- IBM Network Card for Ethernet (10BaseT/10Base2)
- IBM Network Card for Token Ring
- IBM Twinax SCS Interface Card
- IBM Coax SCS Interface Card

If you have purchased optional network interface cards for your printer, install them in the printer following the steps listed in this section. Two cards to connect to two different systems can be installed.

Note: You cannot install two identical cards. For example, the printer cannot accept two IBM Network Cards for Ethernet, but can accept an IBM Ethernet card and an IBM Token Ring card.

A system or network administrator should review the documentation shipped with the network interface card to configure the printer and your computing environment correctly. *IBM Network Printers: Ethernet and Token Ring Configuration Guide* is shipped with the Ethernet and Token Ring network interface cards. *IBM Network Printers: Twinax/Coax Configuration Guide* is shipped with the Twinax and Coax network interface cards.

Only a system or network administrator should configure your network computing environment for this printer.

Installing a Network Interface Card

Important

Follow the instructions for handling static-sensitive devices described on page 127.

Use the following procedure to install a Network Interface card:

1. Unpack the network interface card, and set aside the software and documentation that arrived with the card.
2. If you are installing a token ring card, you must complete the following procedure to set the line speed for the card. If you are not installing a token ring card, skip this step and go to Step 3.
 - a. Lay the token ring card in front of you with the faceplate towards you.

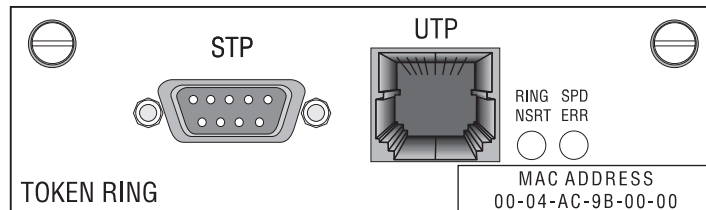

- b. On the right, rear side are six pins and two small jumpers.
 - If you are installing the card for a 4Mbps network, place a jumper over the pins labeled 4.

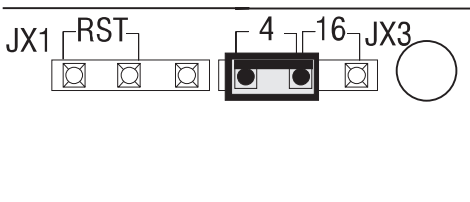

- If you are installing the card for a 16Mbps network, place a jumper over the pins labeled 4 and 16.

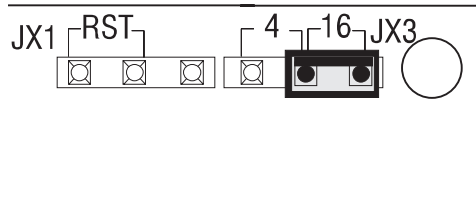

3. Switch the printer power off.

Attention: Do not switch the power off if the printer is printing a page. This action jams the printer.

CAUTION:

Failure to turn off the printer before working with its internal components can result in electric shock.

4. Unplug the printer from the wall outlet.
5. Remove the power cord from the back of the printer.
6. Move to the back of the printer. Two slots for interface cards are located at the right side of the back of the printer. If you are installing only one card, use the top slot.

7. Loosen and remove the thumbscrews that hold the slot cover. Remove the cover and store it for future use.

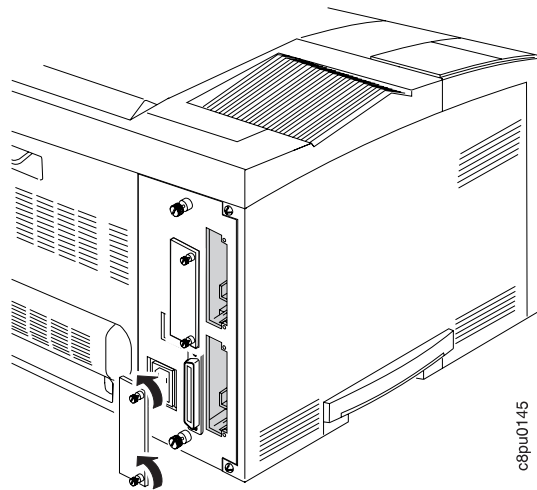

8. Insert the card into the slot, aligning it with the two guides at the top and bottom of the slot. Slide the card vertically into these guides, pushing slowly and firmly until you can feel the card seat into the socket.

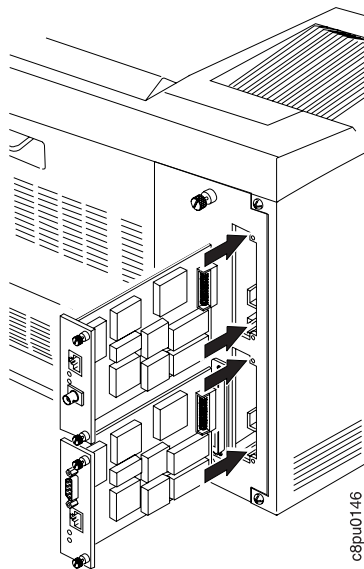

9. Tighten the thumbscrews.

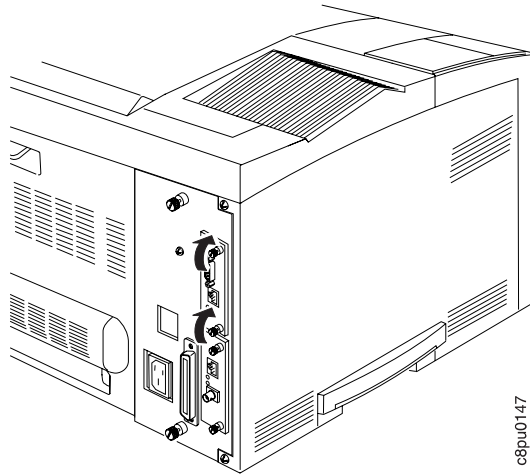

10. If you have a second card to install, repeat Steps 7 to 9.
11. Now that you have installed the card, your system administrator will need to configure the printer and its computing environment. See *IBM Network Printers: Ethernet and Token Ring Configuration Guide* for Ethernet and Token Ring cards. See *IBM Network Printers: Twinax/Coax Configuration Guide* for twinax and coax cards. These documents are shipped with the cards.

The Duplex Unit Option

This section describes how to install and remove the optional duplex unit. The duplex unit should be installed before installing the 500-sheet paper tray option or other options that increase the weight of the printer.

The optional duplex unit allows you to make two-sided prints. Acceptable paper sizes and weights for use with the duplex unit are as follows:

Paper Size	A4, Letter, 13-in. Legal (Folio), 14-in. Legal
Paper Weight	16 lb to 28 lb (60 grams/meter ² to 105 grams/meter ²)

Installing the Duplex Unit

Use the following procedure to install the duplex unit:

1. Switch the printer power off.
2. Unplug the printer from the wall outlet.
3. Remove the power cord from the back of the printer.

CAUTION:

Do not touch the fuser (labeled) inside the printer. It can be extremely hot. Always wait at least 40 minutes for the fuser to cool down.

4. Press the release lever and open the back cover.

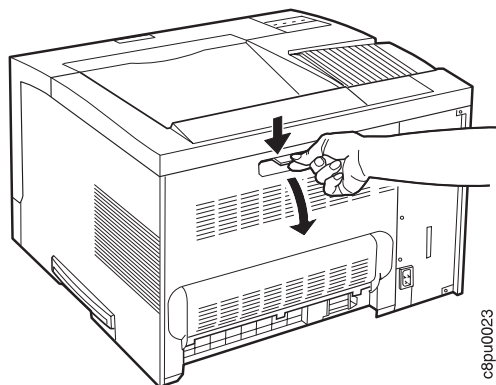

c8pu0023

5. Unpack the duplex unit.
6. Place the duplex unit into the guide channels that are located on both sides of the back opening and slide the unit into the printer. Keep pushing until the duplex unit locks into place.

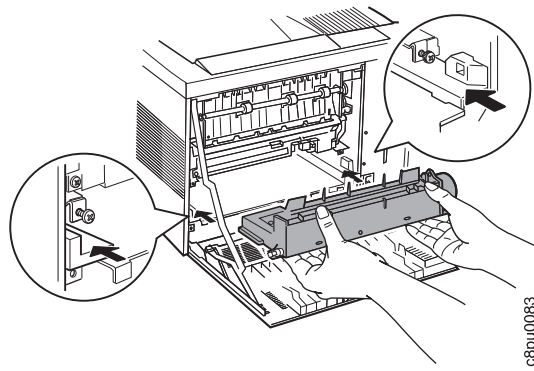

7. Close the back cover.
8. Connect the power cord to the back of the printer.
9. Connect the other end of the power cord to a grounded AC outlet.
10. Switch the printer power on.
Note: If the operator panel displays any message other than READY, see Appendix B, "Printer Messages" on page 191 for more information.
11. To make two-sided printing the printer default, set the Paper Menu DUPLEX item to ON. See "Making Duplex or Simplex Printing the Printer Default" on page 16.
12. To verify that the duplex unit is installed correctly, you can print a list of PCL5e fonts. See "Printing a List of PCL5e Fonts" on page 17.
Attention: During duplex printing, the leading edge of each sheet of paper briefly appears in the exit tray, and then disappears back into the printer. Do not remove these sheets of paper until they reappear with both sides printed.
13. Make sure you update your printer driver to indicate the duplex unit is installed.

Removing the Duplex Unit

Use the following procedure to remove the duplex unit:

1. Switch the printer power off.
2. Unplug the printer from the wall outlet.
3. Remove the power cord from the back of the printer.

CAUTION:

Do not touch the fuser (labeled) inside the printer. It can be extremely hot. Always wait at least 40 minutes for the fuser to cool down.

4. Press the release lever to open the back cover.

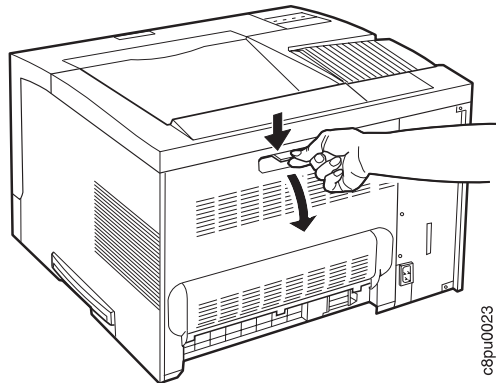

c8pu0023

CAUTION:

Do not touch the small motor that is located at the right end of the duplex unit. It may be hot.

5. Press in on the two green lock buttons located on both ends of the duplex unit, and slide the unit out of the printer.

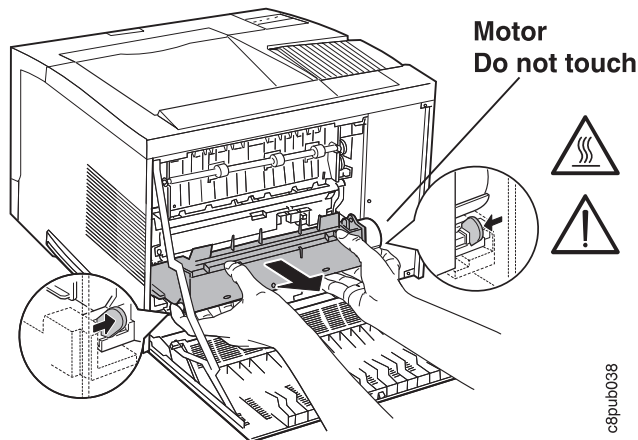

c8pub038

6. Close the back cover.

7. Connect the power cord to the back of the printer.
8. Connect the other end of the power cord to a grounded AC outlet.
9. Switch the printer power on.

Note: If the operator panel displays any message other than READY, see Appendix B, "Printer Messages" on page 191 for more information.

10. Make sure you update your printer driver to indicate the duplex unit has been removed.

The 500-Sheet Paper Tray Option (Tray 2, Tray 3)

Each 500-sheet paper tray option consists of:

- A paper tray support unit that attaches to the printer
- A paper tray that holds the paper and is inserted into the support unit.

This section describes how to install one or two paper tray support units with 500-sheet paper trays and how to remove and uncouple the two support units. Because this option, when installed, significantly increases the weight of the printer, consider installing the trays after other options are installed.

Acceptable paper sizes and weights for the 500-sheet paper trays are as follows:

Paper size	A4, Letter, 13-in. Legal (Folio), 14-in. Legal,
Paper weight	16- to 28-pound paper (60 grams/meter ² to 105 grams/meter ²)
Paper Capacity	Up to 54 mm maximum stack height

See “Loading Paper into the 500-Sheet Paper Trays (Tray 2, Tray 3)” on page 36 for instructions on loading paper.

Preparing the Printer

Use the following procedure to prepare the printer before installing optional paper trays:

1. Switch the printer power off.
2. Unplug the printer from the wall outlet.
3. Remove the power cord from the back of the printer.
4. Unpack the paper tray support unit or units (if you have two). Place each paper tray support unit on a flat stable surface.

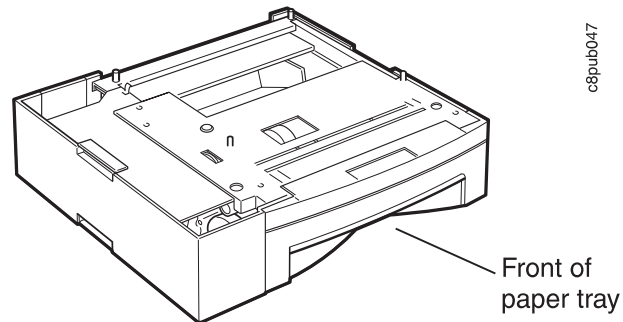

5. Remove the tape and packing materials from the paper tray support unit.

Note: The small piece of tape has a small piece of protective plastic attached to it. Normally, the plastic come out when you remove the tape. If it does not come out with the tape, make sure you remove it.

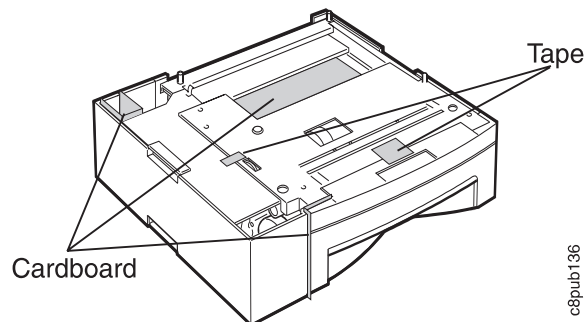

6. At the back of the support unit, hold down the cardboard packing material that is inside the paper tray as you pull the paper tray out of the support unit.

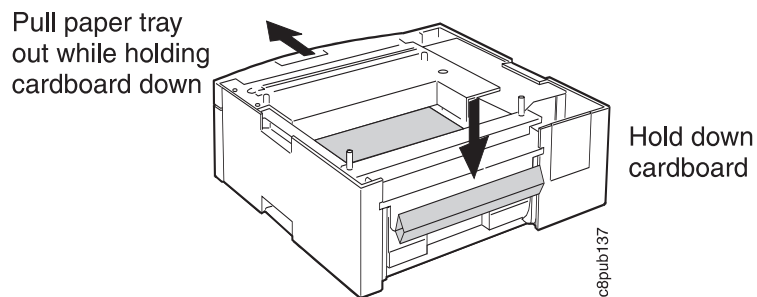

7. Remove the cardboard from inside the paper tray and set aside the locking clips that are packed inside the tray.
8. Save the packing materials for future use.
9. If you have two trays, go to “Stacking Two 500-Sheet Paper Trays” on page 147. Otherwise, go to “Placing the Printer on the Paper Tray Support Unit” on page 151.

Stacking Two 500-Sheet Paper Trays

Use the following procedure to stack and fasten two optional 500-sheet paper tray support units:

1. Lift one of the paper tray support units by the recessed grips and set it on top of the other support unit. The front of each paper tray must face the same direction.

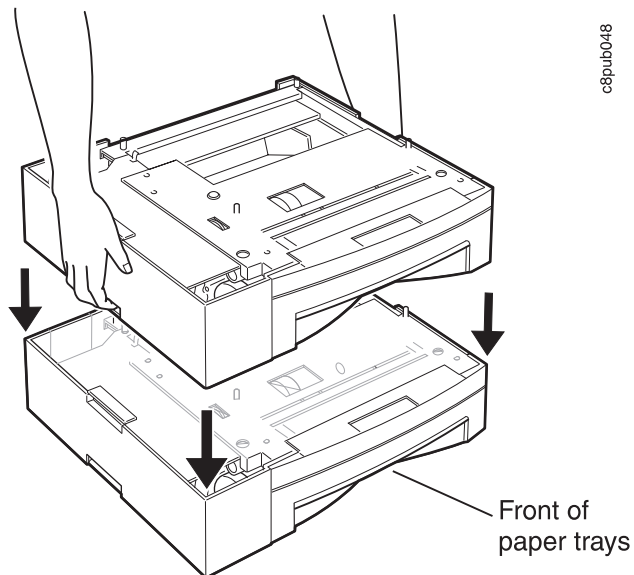

2. Make sure the upper support unit is aligned with the lower support unit and that the upper unit is correctly seated on the lower unit. The front of the paper trays should be aligned.

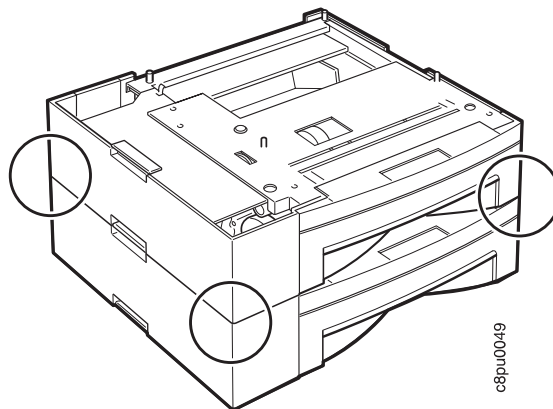

3. Fasten the left side locking clip between the two support units, as follows:
 - a. Snap the end of the locking clip into the notch located on the support unit.
 - b. Close the locking clip. It snaps into place.

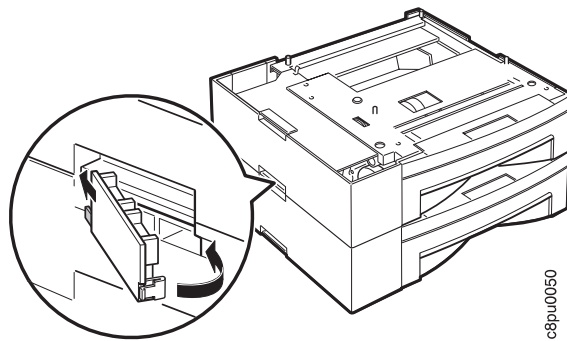

4. Fasten the right side locking clip between the two support units, as follows:
 - a. Snap the end of the locking clip into the notch located on the support unit.
 - b. Close the locking clip. It snaps into place.

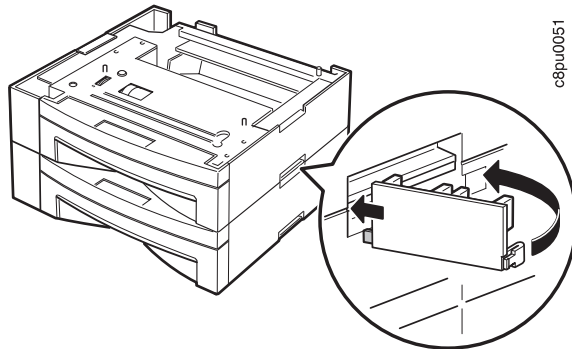

5. Open the power-cord connector cover that is located on the back panel of the lower support unit. Release the latch and open and remove the cover.

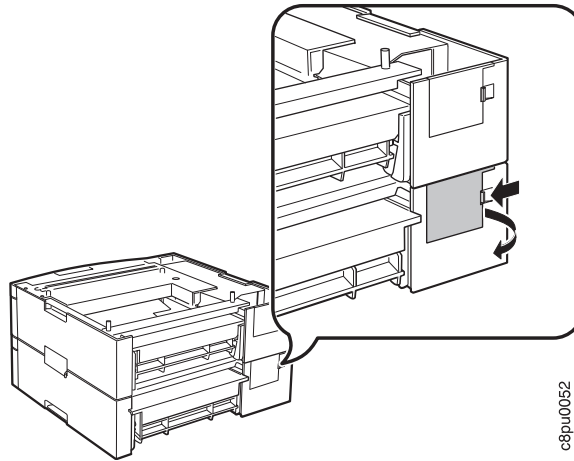

6. To connect power between the two support units, plug the lower support unit power-cord connector into the upper unit plug jack. It snaps into place.

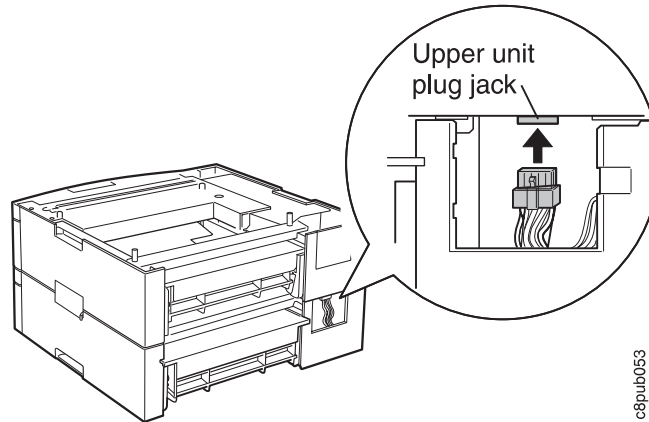

7. Reinstall the power-cord connector cover onto the lower support unit, as follows:
 - a. Snap the end of the cover into the notch on the support unit.
 - b. Close the cover. It snaps into place.

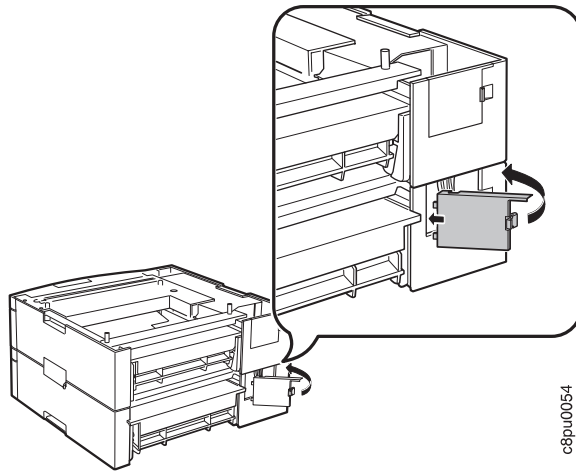

c8p.u054

Placing the Printer on the Paper Tray Support Unit

Use the following procedure to place the printer on the paper tray support unit:

Attention: Printer power should be off before performing this procedure.

1. Make sure that the support unit (upper unit, if you have two) power-cord connector and wire harness are inside the recessed area of the support unit.

Attention: Make sure neither the power-cord connector nor the wire harness hang over the sides of the support unit.

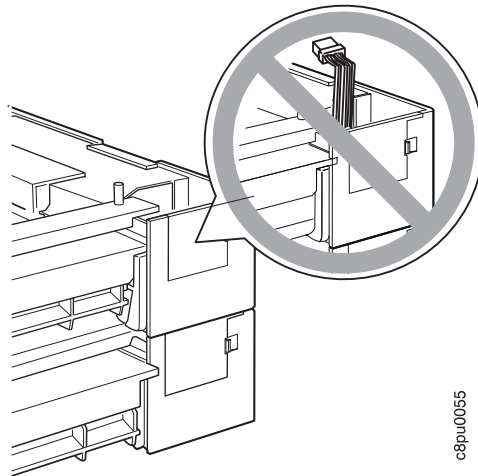

2. Facing the front of the printer, hold the printer by the recessed grips on both sides, and set it on top of the support unit.

Note: Make sure you align the corners of the printer with the corners of the support unit.

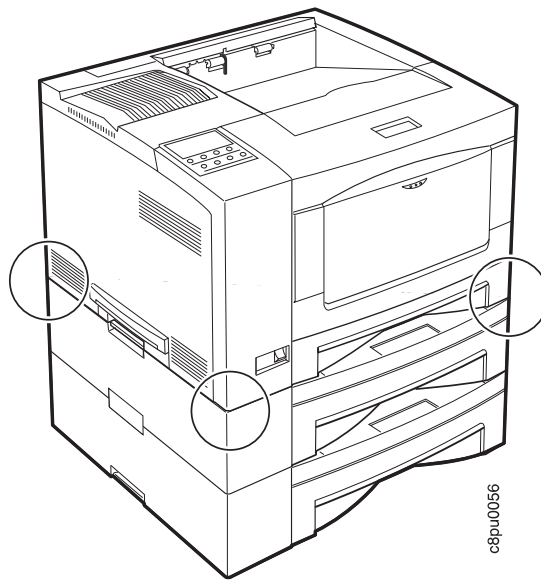

3. Making sure the printer is firmly seated on the support unit, fasten the left side locking clip, as follows:
 - a. Snap the end of the locking clip into the notch located on the support unit.
 - b. Close the locking clip. It snaps into place.

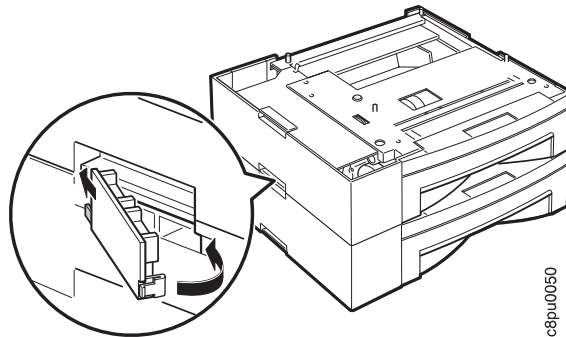

4. Fasten the right side locking clip on the support unit, as follows:
 - a. Snap the end of the locking clip into the notch located on the support unit.
 - b. Close the locking clip. It snaps into place.

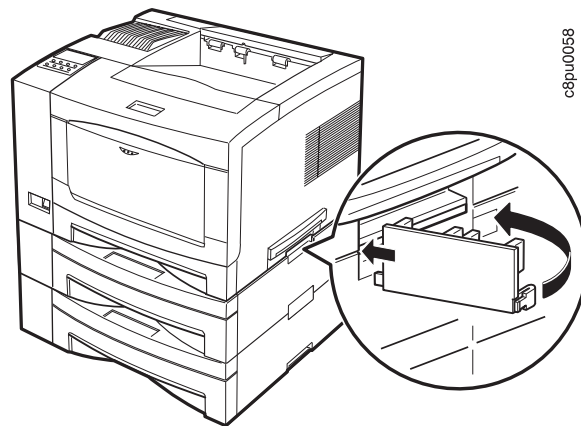

5. Open the power-cord connector cover that is located on the back panel of the upper support unit. Release the latch and open and remove the cover.

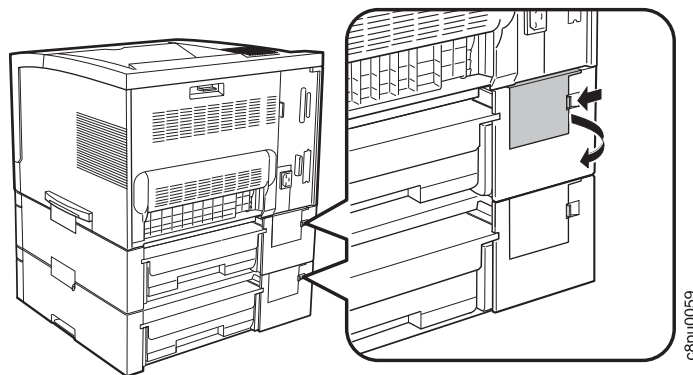

6. To connect power between the printer and the upper support unit, plug the upper support unit power-cord connector into the printer plug jack. It snaps into place.

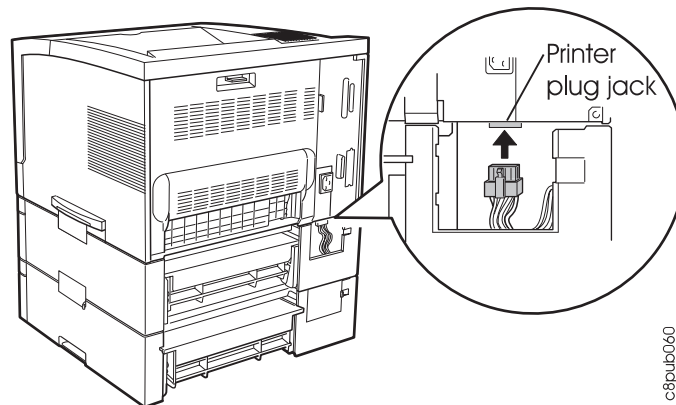

7. Reinstall the power-cord connector cover onto the upper support unit, as follows:
 - a. Snap the end of the cover into the notch on the support unit.
 - b. Close the cover. It snaps into place.

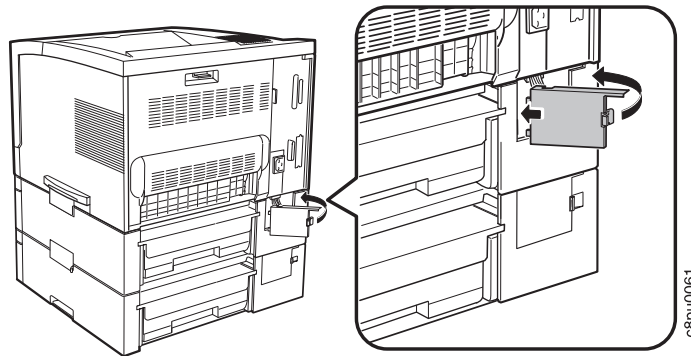

8. Connect the power cord to the back of the printer.
9. Connect the other end of the power cord to a grounded AC outlet.

10. Switch the printer power on.

Note: If the operator panel displays any message other than READY, see Appendix B, “Printer Messages” on page 191 for more information.

CAUTION:

The printer is extremely heavy with the optional paper trays installed. Always remove the optional paper tray or trays before lifting the printer. Use care or ask for assistance when you lift the printer.

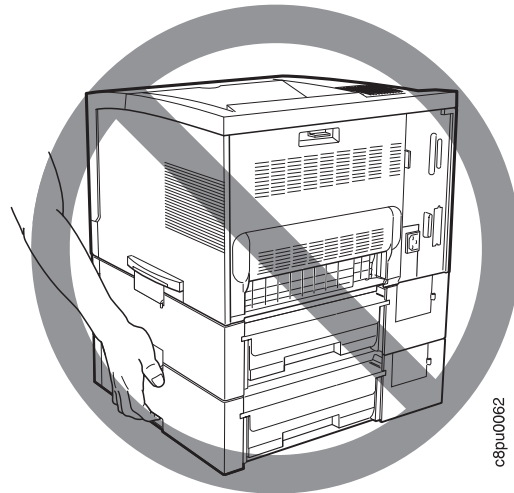

11. From the Paper Menu, set SOURCE to TRAY2 to use the upper tray or TRAY3 to use the lower tray as the default source tray (see “Paper Menu” on page 77).
12. Make sure you update your printer driver to indicate Tray 2 or Tray 2 and Tray 3 are installed.

Removing the 500-Sheet Paper Tray Support Units

Use the following procedure to remove the 500-sheet paper tray support unit:

1. Switch the printer power off.
2. Unplug the printer from the wall outlet.
3. Remove the power cord from the back of the printer.
4. Open the power-cord connector cover that is located on the back panel of the lower support unit. Release the latch and open and remove the cover.

Note: If two support units are installed, remove both covers.

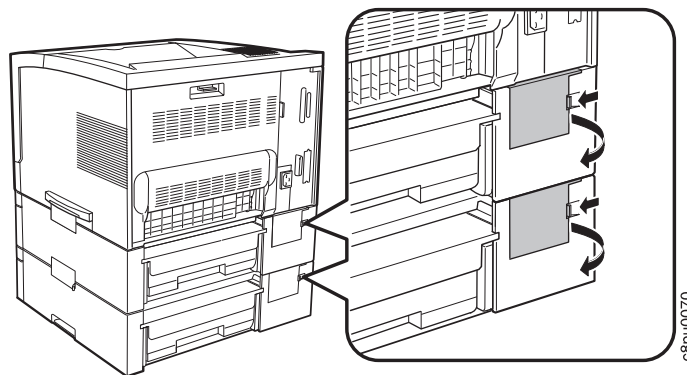

5. Unplug the power-cord connector from the printer jack by holding the power-cord connector (not the wire harness) and pulling straight down.

Note: If two support units are installed, unplug both power-cord connectors.

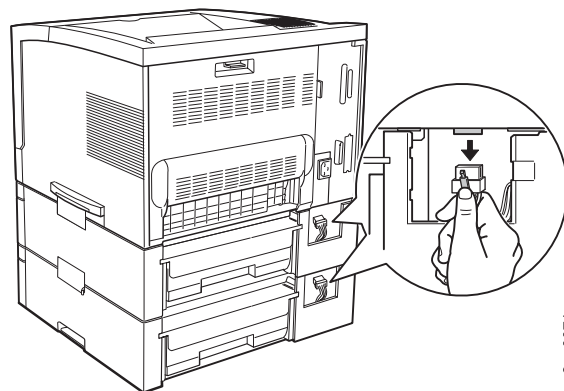

6. Remove the left locking clips between the printer and the top support unit.

Note: If two support units are installed, remove only the joint between the printer and upper support unit.

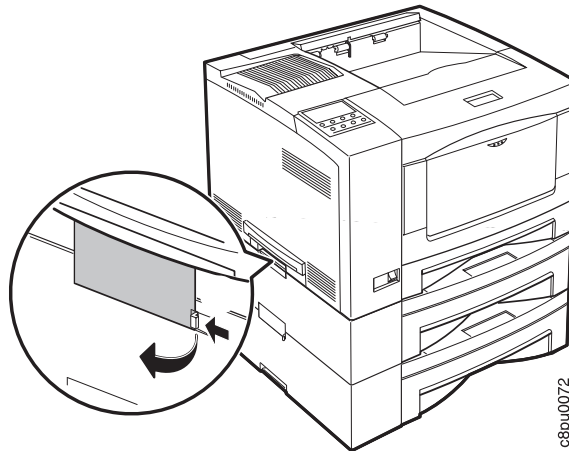

7. Remove the right locking clips between the printer and the top support unit.

Note: If two support units are installed, remove only the joint between the printer and upper support units.

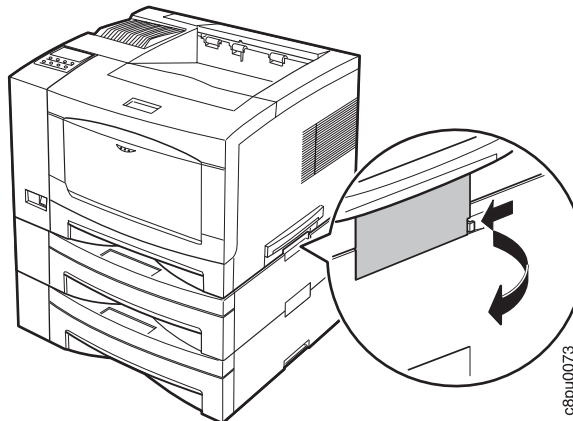

8. Facing the front of the printer, hold the printer by the recessed grips on both sides, and carefully lift it off the support unit. Set the printer on a flat stable surface.

Note: If two support units are installed, they should still be connected with locking clips when you perform this step.

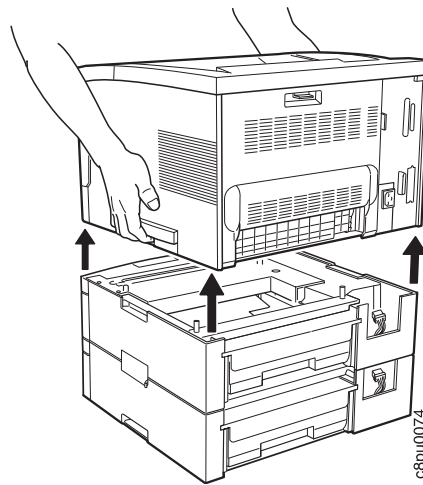

9. Reinstall the power-cord connector covers on the support unit.
10. Store the locking clips for future use.
11. If you have only one support unit, store it for future use. If you have two, go to "Uncoupling Two 500-Sheet Paper Tray Support Units" on page 159.
12. Make sure you update your printer driver to indicate Tray 2 has been removed.

Uncoupling Two 500-Sheet Paper Tray Support Units

1. Remove the left side locking clip.

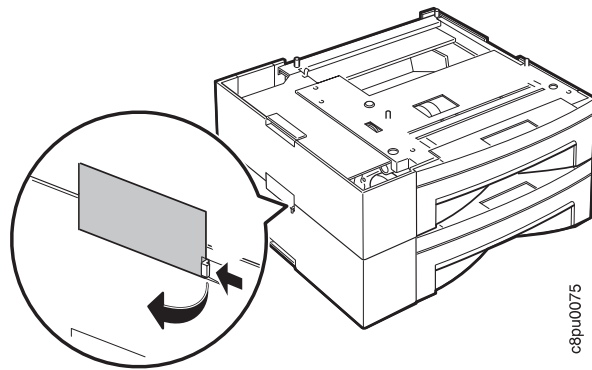

2. Remove the right side locking clip.

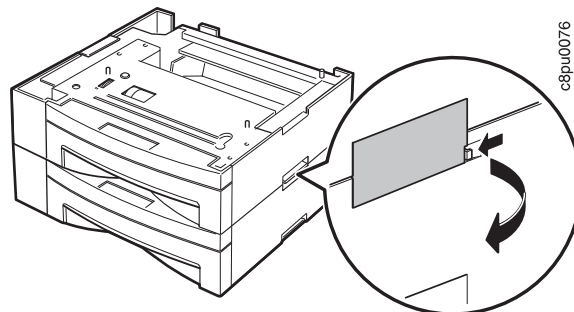

3. Hold the upper support unit by the recessed grips and lift it off the lower unit.

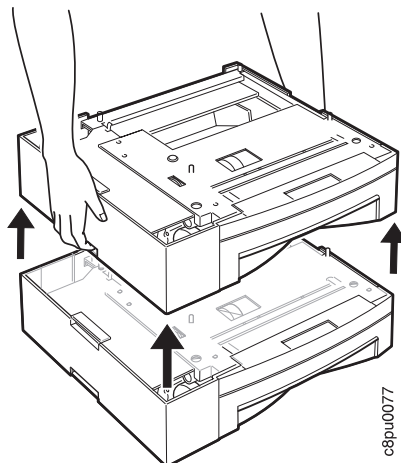

4. Store the support units and locking clips for future use.

5. Make sure you update your printer driver to indicate Tray 2 or Tray 2 and Tray 3 have been removed.

The 500-Sheet Offset Paper Output Bin Option

This section describes how to install and remove the optional 500-sheet offset paper output bin. You cannot install the 500-sheet offset paper output bin if you already have the mailbox option installed on your printer.

Installing the 500-Sheet Offset Paper Output Bin

Use the following procedure to install the 500-sheet offset paper output bin:

Note: This procedure should be done from the back of the printer.

1. Switch the printer power off.
2. Unplug the printer from the wall outlet.
3. Remove the power cord from the back of the printer.

CAUTION:

Do not touch the fuser (labeled) inside the printer. It can be extremely hot. Always wait at least 40 minutes for the fuser to cool down.

4. Press the release lever to open the back cover of the printer.

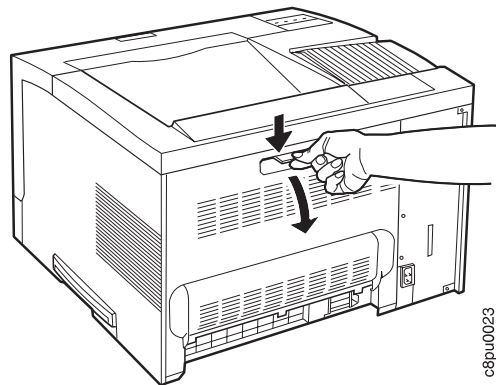

5. Push up on the underside of the small top cover of the printer and remove it.

Note: Do not lose the small top cover. It must be reinstalled if you remove the 500-sheet offset paper output bin.

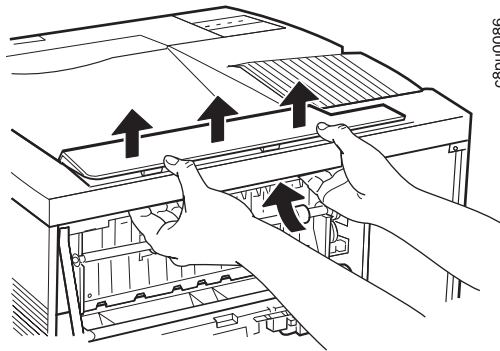

6. Close the back cover of the printer.
7. Unpack the 500-sheet offset paper output bin and remove the packing cardboard and tape.

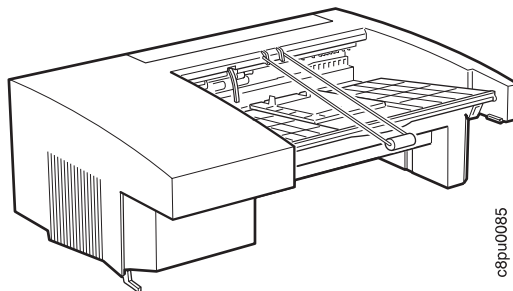

8. Hold the paper output bin with the back of the bin facing you.

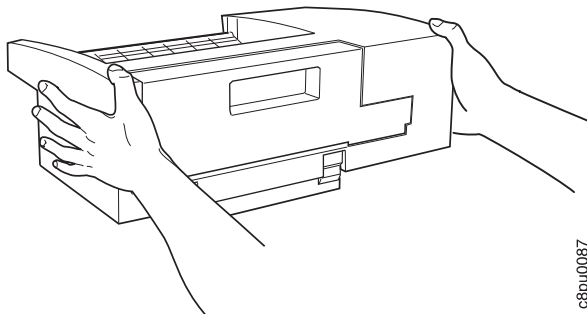

9. Facing the back of the printer, insert the locating hook on the paper output bin into the far right ventilating slot located on the top right of the printer. Carefully seat the paper output bin onto the printer, taking care to align the plug on the paper output bin with the corresponding receptacle on the top of the printer.

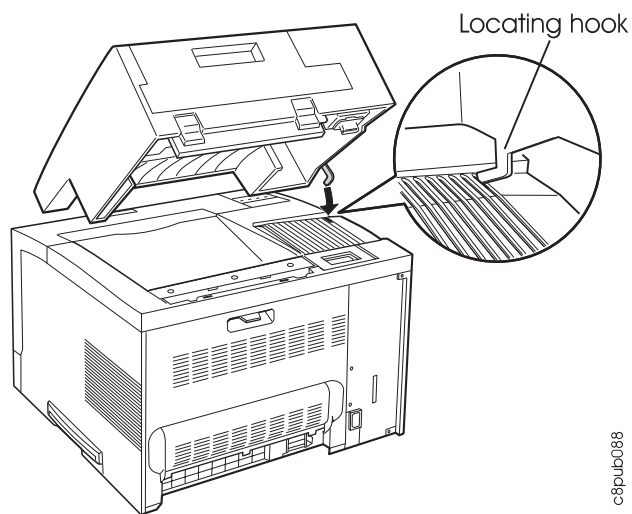

10. Make sure the paper output bin is correctly aligned and firmly seated on the top of the printer.

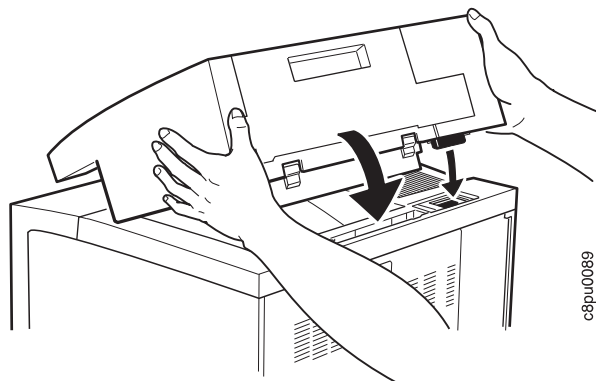

11. Lift the paper weight out of the way, open the paper tray on the paper output bin, then return the paper weight to the original position on the paper output bin.

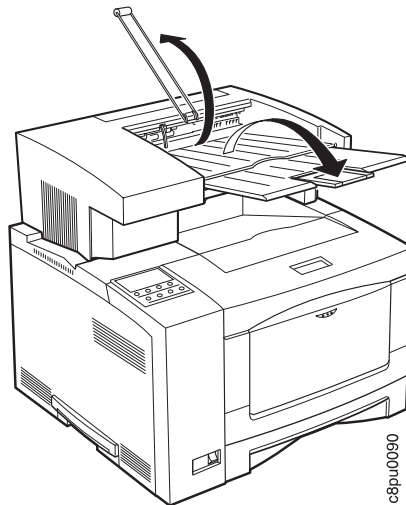

12. If you are printing on long paper, pull out the tray extension.

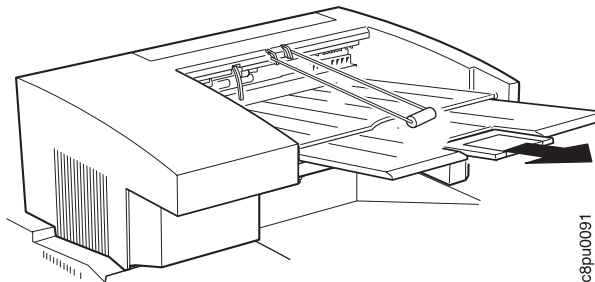

13. From the Paper Menu, set OUTPUT to OFFSET to set the 500-sheet offset paper output bin as the default output bin (see "Paper Menu" on page 77).
14. Make sure you update your printer driver to indicate the the 500-sheet offset paper output bin (Offset) is installed.

Removing the Offset Paper Output Bin

Use the following procedure to remove the 500-sheet offset paper output bin:

1. Switch the printer power off.
2. Unplug the printer from the wall outlet.
3. Remove the power cord from the back of the printer.
4. Fold the paper tray to its stored position and fold the paper weight onto the tray.

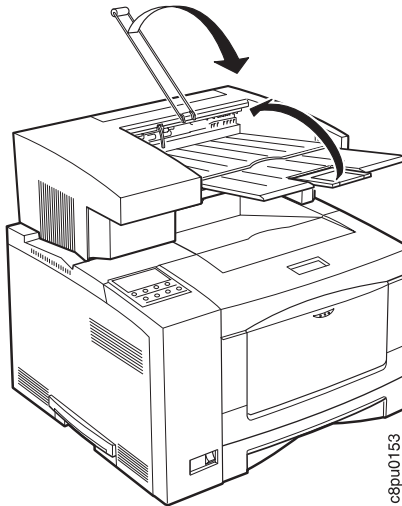

5. Facing the back of the printer, press the release buttons with your thumbs while you push up and remove the paper output bin.

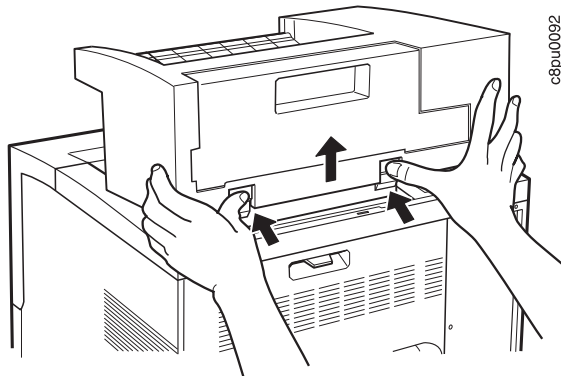

6. Place the paper output bin on a flat stable surface.
7. Reinstall the small top cover. First position the edge of the cover that is closest to the front of the printer and then snap the cover in place.

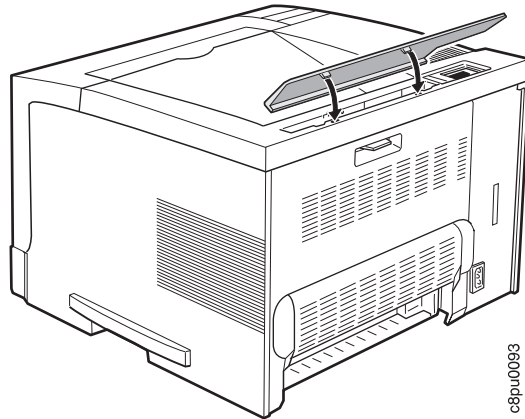

8. Store the paper output bin for future use.
9. Make sure you update your printer driver to indicate the the 500-sheet offset paper output bin (Offset) has been removed.

The 10-Bin Mailbox Option

The mailbox directs finished print jobs to designated bins. You cannot install a mailbox if you already have the 500-sheet offset paper output option installed on your printer.

Paper size	A4 and Letter
Paper weight	20 lb to 28 lb (75 grams/meter ² to 105 grams/meter ²)
Bin capacity	45 sheets of paper in each bin

Installing the 10-Bin Mailbox

Use the following procedure to install the 10-bin mailbox:

1. Switch the printer power off.
2. Unplug the printer from the wall outlet.
3. Remove the power cord from the back of the printer.
4. Unpack the mailbox.
5. Put the mailbox on the edge of a flat surface to avoid damaging the power-cord connector located on the bottom of the mailbox.

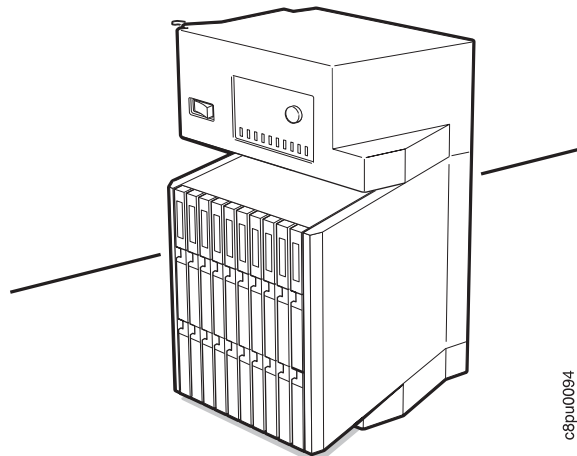

6. Make sure the mailbox is switched off.

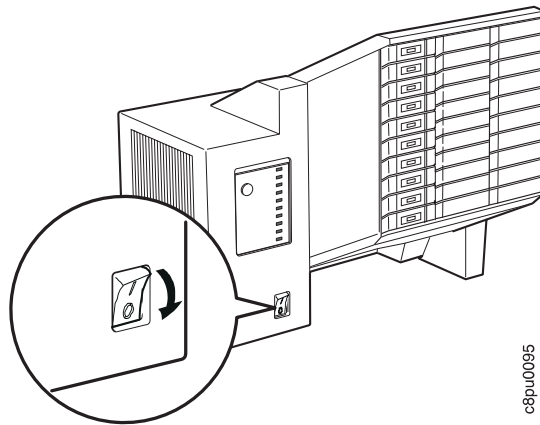

c8pu0095

CAUTION:

Do not touch the fuser (labeled) inside the printer. It can be extremely hot. Always wait at least 40 minutes for the fuser to cool down.

7. Press the release lever and open the back cover.

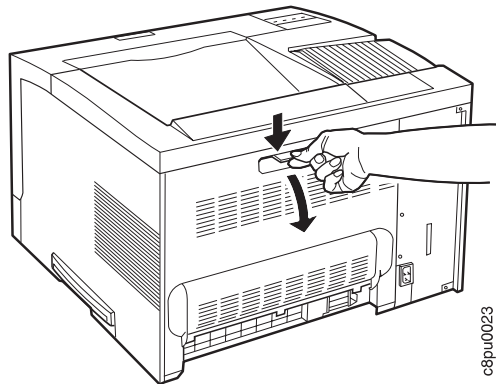

c8pu0023

8. Push up on the underside of the small top cover and remove it.

Note: Do not lose the small top cover. It must be reinstalled if you remove the mailbox.

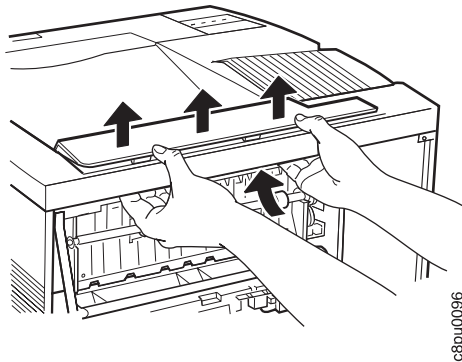

9. Close the back cover of the printer.
10. Hold the mailbox by the grips that are located under the bins and on the back cover.

Attention: Use care that you do not accidentally open the back cover of the mailbox while holding it in this position.

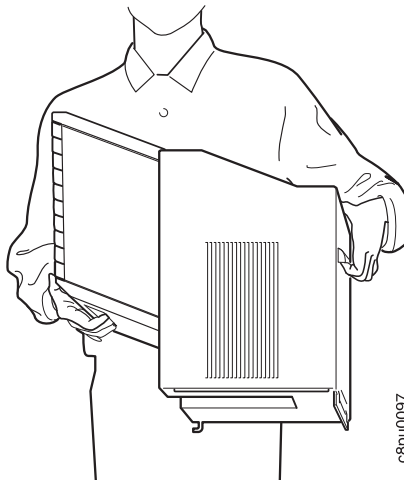

11. Facing the back of the printer, insert the hook on the mailbox into the far right ventilating slot located on the top right of the printer. Carefully seat the mailbox onto the printer, taking care to align the mailbox plug with the corresponding receptacle on the top of the printer.

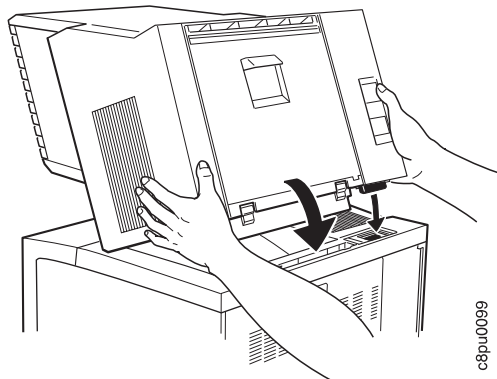
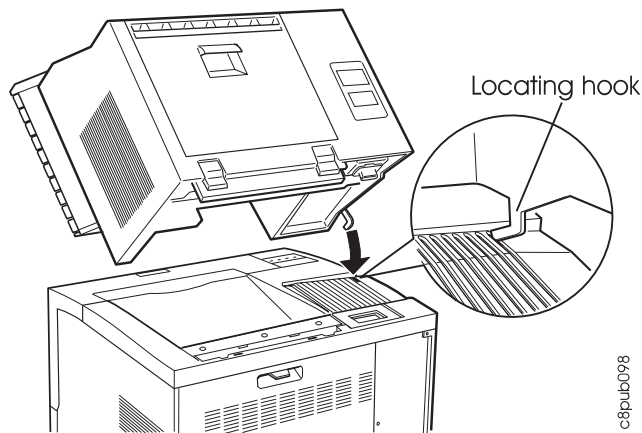

12. Plug the mailbox power cord into the lower power connector at the back of the mailbox. Plug the free end of the mailbox power cord into the printer.

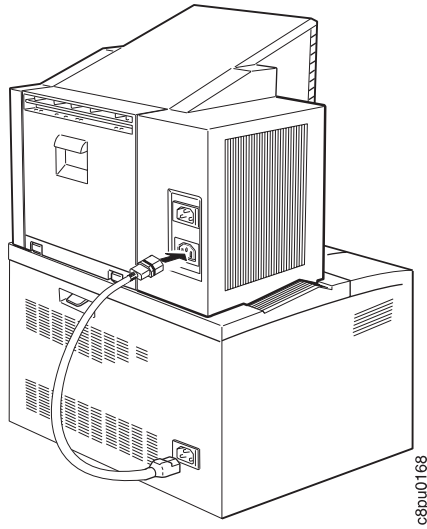

13. Plug the printer power cord into the upper power connector at the back of the mailbox. Plug the free end of the printer power cord into the wall outlet.

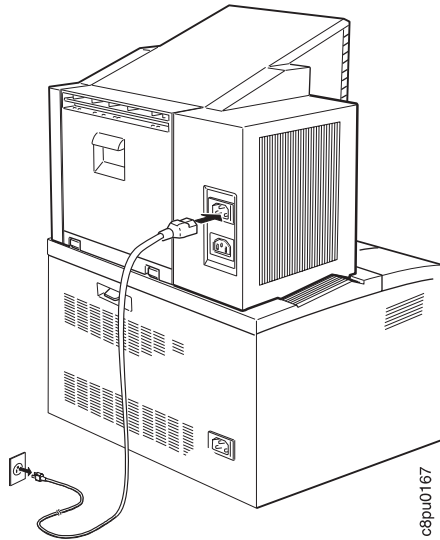

14. Switch on the mailbox power.
15. Switch on the printer power.

Note: If the operator panel displays any message other than READY, see Appendix B, "Printer Messages" on page 191 for more information.

16. Use the Mailbox Menu to enable the bins and manage the output. See “Using the Mailbox” on page 44.
17. Make sure you update your printer driver to indicate the mailbox is installed.

Removing the Mailbox

Use the following procedure to remove the mailbox:

1. Switch the printer power off.
2. Switch the mailbox power off.
3. Unplug the power cord from the wall outlet.
4. Remove both power cords from the back of the mailbox.
5. Unplug the power cord from the back of the printer. Keep this power cord with the mailbox.
6. Facing the back of the printer, pull up on the mailbox with one hand while you press the release buttons with the other hand.

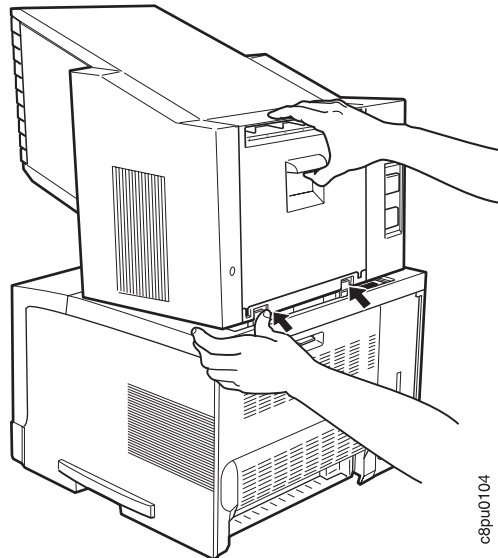

c8pu0104

7. Firmly hold the mailbox, and lift it off the printer. Place the mailbox on a flat stable surface.

8. Reinstall the small top cover. Position the printer edge of the cover first and then snap the cover in place.

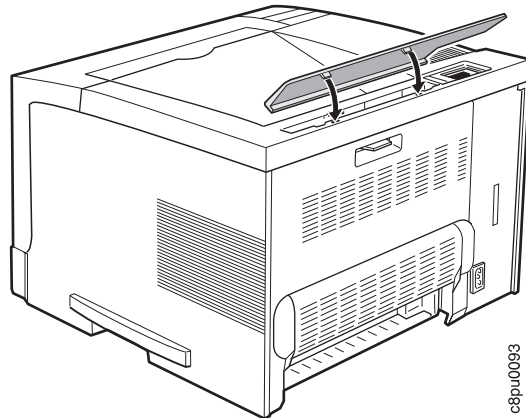

9. Store the mailbox and power cord for future use.
10. Make sure you update your printer driver to indicate the mailbox has been removed.

The Envelope Feeder Option

The envelope feeder lets you print large runs of various envelope sizes.

Envelope sizes	Commercial #10 — 4.125 x 9.5 in. (104.8 x 241.3 mm) Monarch — 3.875 x 7.5 in (98.4 x 190.5 mm) DL — 110 x 220 mm (4.4 x 8.8 in.) C5 — 62 x 229 mm (6.48 x 9.16 in.)
Envelope weights	16 lb to 28 lb (60 grams/meter ² to 105 grams/meter ²)
Envelope feeder capacity	75 envelopes

Installing the Envelope Feeder

Use the following procedure to install the envelope feeder:

1. Switch the printer power off.
2. Unplug the printer from the wall outlet.
3. Remove the power cord from the back of the printer.
4. Unpack the envelope feeder and save the packing materials for future use.
5. Open the auxiliary tray by pushing in on the top of the auxiliary tray.

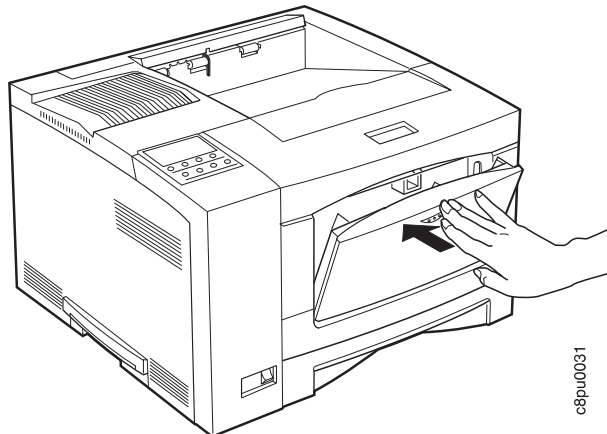

c8pu0031

6. Open the small cover located on the left side of the open auxiliary tray.

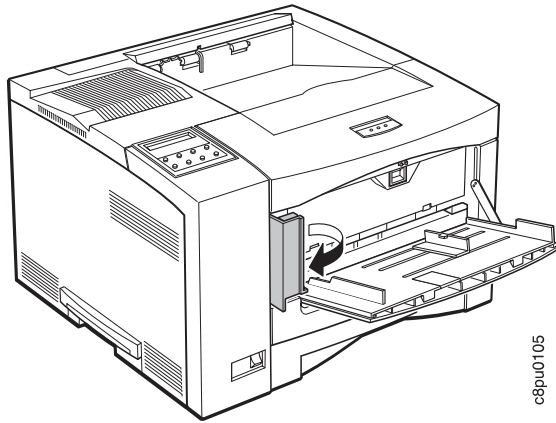

c8pu0105

7. Squeeze the tab and remove the inner cover. Store the cover for future use.

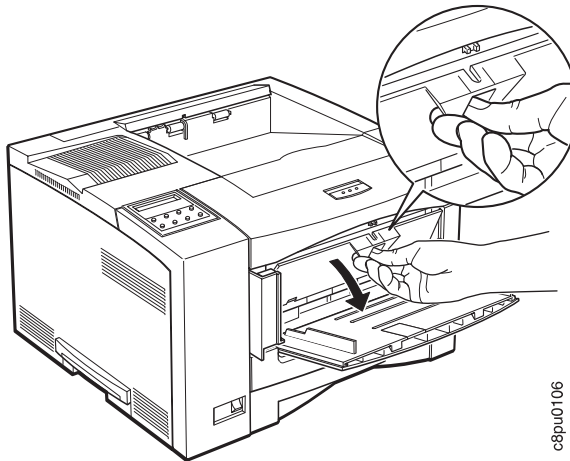

c8pu0106

- Position the envelope feeder as shown in the illustration and push it as far as it will go into the auxiliary tray.

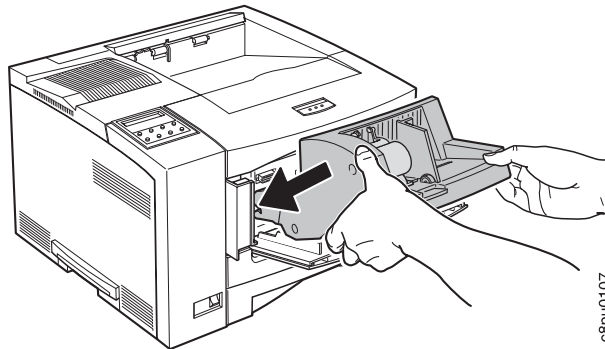

c8pu0107

- Plug in the printer.
- Switch on the printer power.
Note: If the operator panel displays any message other than READY, see Appendix B, "Printer Messages" on page 191 for more information.
- For information on how to use the envelope feeder, see "Loading Envelopes into the Envelope Feeder" on page 40.
- Make sure you update your printer driver to indicate the envelope feeder is installed.

Important!

Note that you need to remove the envelope feeder before you can open the front cover of the printer.

Removing the Envelope Feeder

Use the following procedure to remove the envelope feeder:

1. Pull out and remove the envelope feeder.

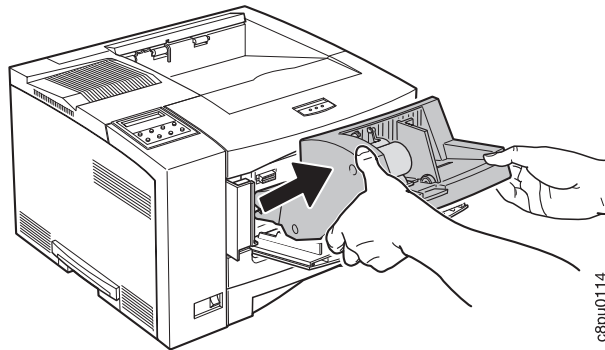

2. Reinstall the inner cover.

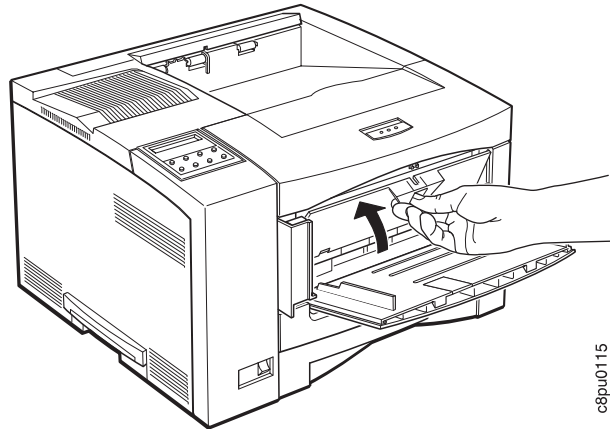

3. Close the small cover.

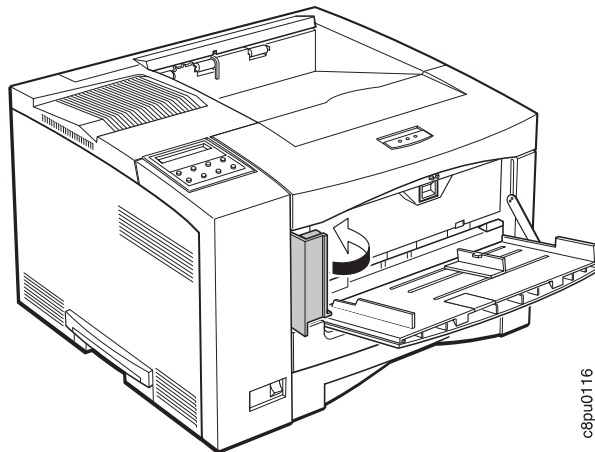

c8pu0116

4. Close the auxiliary tray.

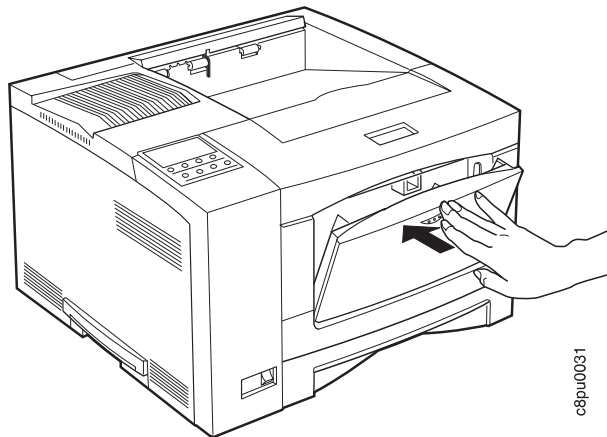

c8pu0031

5. Store the envelope feeder for future use.
6. Make sure you update your printer driver to indicate the envelope feeder has been removed.

Chapter 8. Configuring Printer Network Addresses

Important

Defining the printer's network address should be performed by a network administrator or someone familiar with network addresses. If you have *IBM Network Printers: Ethernet and Token Ring Configuration Guide*, please refer to it when you configure your Ethernet or Token Ring card.

Use this section to set the following values from the operator panel:

- IP address
- Subnet mask
- Gateway address
- Locally administered MAC address

Note: The MAC address is the Globally Administered Address (GAA). The MAC address can be changed to the Locally Administered address (LAA).

Setting IP, Subnet Mask, and Gateway Addresses

To set an IP, subnet mask, or gateway address for the printer, perform these steps:

1. Press the **Online** key to take the printer OFFLINE.
2. Press the **Menu** key until the operator panel displays ETHERNET MENU or TOKEN RING MENU.
3. Press the **Item** key until the operator panel displays address to change (IP ADDRESS, SUBNET MASK, or GATEWAY ADDRESS). This example shows how to change the IP ADDRESS.
4. Press the **Continue/Enter** key. For a new printer whose IP address has not yet been set, the operator panel displays:

```
IP ADDRESS  
0<0.0.0 *
```

The “<” indicates the field whose value you can change at this point.

5. Press the **Value** key until the desired value is displayed. The range of the address values is zero to 255. To increment the value by 10, press and hold the **Value** key.
6. When the operator panel displays the value you want, press **Continue/Enter**. The “<” moves to the next value, for example:

```
10.0<0.0
```

7. Press the **Value** key until the desired value is displayed, then press the **Continue/Enter** key.
8. Repeat step 7 until all four values have been set, then press the **Continue/Enter** key to set the address. The value has been set if an asterisk (*) displays to the right of the value, for example:

```
9.99.40.2 *
```

9. Press the **Online** button to display the **Ready** message. The panel displays the message **I/O Initializing** and writes the new addresses to non-volatile memory. (This process takes a few minutes.) **Do not power off the printer** while the **I/O Initializing** message is displayed.

Beware of Beaconing

When you turn the printer off, wait at least two or three seconds before turning it back on. A quick off-on may cause a Token Ring card to start beaconing.

Setting the Locally Administered MAC Address (LAA)

Network Administrator Tip

Each network card comes with a unique, pre-assigned MAC address printed on its faceplate and set at the factory. The following procedure allows you to use locally administered addresses (LAA) instead of the factory value. Resetting the printer to factory defaults sets the LAA back to the MAC address. IBM recommends that you contact your network administrator before you change the MAC address because each LAA must be unique on the network.

To change the LAA address for the printer:

1. Press the **Online** key to take the printer offline.
2. Press the **Menu** key until the operator panel displays ETHERNET MENU or TOKEN RING MENU.
3. Press the **Item** key until the operator panel displays the following, if you are using Ethernet:
ETHERNET MENU
MAC ADDRESS
4. Press the **Continue/Enter** key. For a new printer whose MAC address has not yet been changed, the operator panel displays the unique MAC address that came with the card, for example:
MAC ADDRESS 01<
04-AC-9A-00-00
The "<" indicates the value you can change at this point. Notice that the first pair of values (01, in this case) is shown on the same line as "MAC ADDRESS."
5. Press the **Value** key. The asterisk (*) goes away and the value is incremented by one. The range of the address values is zero to 255 hex (that is, FF).
6. Press the **Value** key until the desired value is displayed, then press **Continue/Enter** to set the value. The "<" moves to the next value, for example:
04<AC-9A-00-00
7. Press the **Value** key until the desired value is displayed, then press the **Continue/Enter** key.
8. Repeat step 7 until all six value pairs have been set, then press the **Continue/Enter** key to set the LAA address. The value has been set if an asterisk (*) displays to the right of the value, for example:
MAC ADDRESS 01-
04-9A-01-02-02 *
9. Press the **Online** button to display the **Ready** message. The panel displays the message **I/O Initializing** and writes the new addresses to non-volatile memory. (This process takes a few minutes.) **Do not power off the printer** while the **I/O Initializing** message is displayed.

Beware of Beacons

When you turn the printer off, wait at least two or three seconds before turning it back on. A quick off-on may cause a Token Ring card to start beacons.

Appendix A. Troubleshooting

This section provides simple methods for detecting and solving some of the problems that most frequently occur in printing environments. If your printer does not print your job, follow these steps:

1. Turn the printer off and leave it off for approximately ten seconds. Turn it back on. This action resets the printer to its programmed configuration and may clear the error.
2. Print a sample page to determine whether the problem is with the printer or with the network or cabling leading to the printer. The printer configuration page can be used as a sample page; see "Printing the Printer Configuration Page" on page 13 for instructions. If the problem is with the printer, it is likely that the printer will not print the configuration page. If the problem is in the network or cabling leading to the printer, the configuration page will still print.
3. Use the service checklist provided in this section to identify and detect problems.
4. Call your service representative. If you cannot solve a problem, call your point of purchase or IBM customer technical support (1-800-358-6661 in the U.S.A. and Canada).

Notes:

- a. Have your printer serial number ready (the serial number is printed on the inside right cover, just to the right of the toner cartridge; open the top cover to see it). Also, if you are asked for a machine type, specify 4317.
- b. If you need IBM operating system support (for example, AIX, OS/2, OS/400, and MVS), contact IBM software support (1-800-237-5511 in the U.S.A., 1-800-465-2222 in Canada).

Symptom	Action
A message appears in the message display area	See Appendix B, "Printer Messages" on page 191.
Solid rectangles in the message display area	This usually indicates a problem with the controller card or one of its options (SIMM or hard drive). Response: Make sure the SIMMs are in the correct group of sockets and are installed correctly. See Chapter 7, "Installing Printer Options" on page 127 for instructions on installing the optional SIMMs and hard drive.
No display messages	No message is in the message display area. Response: The printer may not be turned on or the power cord has become unplugged. Press the I on the power switch to power on the printer. Make sure the power cord is plugged in.

Symptom	Action
Changed toner cartridge and the printer does not work	<p>You have installed a new toner cartridge and now want to resume printing, but the printer will not resume printing.</p> <p>Response: Turn off the printer. Open the printer and reseal the toner cartridge. The printer will not print when the toner cartridge is not seated correctly.</p>
Printer never prints the job	<p>Responses:</p> <ol style="list-style-type: none"> 1. Make sure that the printer is running by printing a configuration page. See "Printing the Printer Configuration Page" on page 13. Check the settings for PORT TIMEOUT and PERSONALTY for possible problems. See the appropriate menu for information about the settings for your attachment: <ul style="list-style-type: none"> • "Token Ring Menu" on page 89 • "Ethernet Menu" on page 91 • "Parallel Menu" on page 84 • "Coax Setup Menu" on page 98 • "Twinax Setup Menu" on page 100 2. Make sure your printer driver is installed and is connected to the correct port. 3. For parallel printing, verify the connection by copying a text file (such as config.sys) to that port. If this file prints successfully, suspect a driver problem. <p>Also, make sure you use properly shielded and grounded cables and connectors (IBM part number 63H2804 or its equivalent) that are no more than six feet (1.83 meters) in length.</p> 4. For LAN printing problems, print a configuration page and make sure the appropriate network interface card is installed (look under "Installed Options"). If the card does not appear under installed options, reseal the card (see "The Network Interface Card" on page 135). If problems persist, you may need a new card. <p>Also, refer to <i>IBM Network Printers: Ethernet and Token Ring Configuration Guide</i>, which is shipped with the Ethernet and Token Ring network interface cards.</p> 5. For twinax/coax printing problems, press the TEST button on the back of the twinax or coax card to generate an internal configuration page. This verifies that the card is connected and functional. <p>Also, refer to <i>IBM Network Printers: Twinax/Coax Configuration Guide</i>, which is shipped with the twinax and coax network interface cards.</p>
Output sent to wrong bin	<p>Check the OUTPUT setting in the Paper Menu. See "Paper Menu" on page 77. Note that the job value (set using the printer driver or the application) will override the panel setting.</p>
Wrong size paper selected	<p>Check the SOURCE setting in the Paper Menu. See "Paper Menu" on page 77. Note that the job value (set using the printer driver or the application) will override the panel setting. Also verify the AUXSIZE and ENVSIZE values set in Paper Menu.</p>

Symptom	Action
Paper selected from wrong source	<p>When mismatches occur between size and source (for example, a job specifies a specific tray and a specific paper size, but the requested tray does not contain the requested paper size), the printer attempts to satisfy the size request first. If no tray contains the requested size, a message may indicate the last tray the printer checked.</p> <p>Note that the job value (set using the printer driver or the application) will override the panel setting.</p>
Pages lost after clearing paper jam	<p>Set JAMRECOVERY to ON in the Configuration Menu or using the printer driver. (The driver setting overrides the menu setting.) See "Configuration (Config) Menu" on page 81. Note that this will decrease performance.</p>
Printing is too slow	<p>Consider setting JAMRECOVERY to OFF in the Configuration Menu or using the printer driver. (The driver setting overrides the menu setting.) See "Configuration (Config) Menu" on page 81.</p> <p>If you have installed extra memory, make sure the printer recognizes it. Print a configuration page (see "Printing the Printer Configuration Page" on page 13). Under "Installed Options" look for TOTAL MEMORY. If the printer does not recognize all of the memory you have installed, remove and reseat the memory SIMM. If reseating the memory SIMM does not correct the problem, replace it.</p>
Added paper and the printer does not work	<p>You have added or changed paper and now the printer will not print.</p> <p>Responses:</p> <ol style="list-style-type: none"> 1. Open and close the printer tray and make sure it is positioned correctly. 2. Make sure that paper is loaded correctly with paper under the retaining clips and plastic tabs. See Chapter 3, "Paper Handling" on page 21 for instructions on loading paper.
Printer prints wrong font	<p>You started a print job and the font you see is not what you want.</p> <p>Responses:</p> <ol style="list-style-type: none"> 1. If you are printing IPDS jobs, see if you have turned on font substitution (FONT SUB is set to ON on the IPDS Menu). See "IPDS Menu" on page 104. 2. Print a list of fonts for the type of data you are printing. See "Printing a List of PCL5e Fonts" on page 17, "Printing a List of PostScript Fonts" on page 17, or "Printing a List of IPDS Resident Fonts" on page 17. <p>Note: To print PostScript, the PostScript SIMM must be installed. To print IPDS, the IPDS SIMM must be installed.</p> <ol style="list-style-type: none"> 3. The problem may also be with the software; check to see that you have loaded the correct fonts.
Duplex setting is ignored	<p>The DUPLEX setting on the Paper Menu is the printer default. Your application or driver settings override this default. Make sure that the application, driver, or both (if necessary), specify the correct duplex setting.</p>

Symptom	Action
PostScript printing problem	<p>If your printer is not printing PostScript jobs correctly, the printed output will be unformatted and will include unrecognizable characters (including %% identifiers and other font information). Some print jobs such as screen dumps and PCL5e jobs may print correctly.</p> <p>Response: Print a configuration page. See "Printing the Printer Configuration Page" on page 13. If the controller recognizes the PostScript feature, the configuration page will list the PostScript menu ("PS Menu") options and Installed options will list "PS." If there is no indication of PostScript, remove and reseat the PostScript SIMM. If reseating the SIMM does not correct the problem, replace the SIMM.</p> <p>If the PostScript option is listed on the configuration page (indicating that the SIMM is installed correctly) but the printer still does not print the PostScript job, make sure you have a PostScript printer driver installed and that it is connected to the correct port. If the driver is installed and connected correctly, make sure you have enough memory (see "Memory Requirements" on page 3). If you have enough memory, suspect a problem with the PostScript printer driver or a problem with the print job.</p>
IPDS printing problem	<p>IPDS jobs are not printing.</p> <p>Responses:</p> <ol style="list-style-type: none"> 1. Print a configuration page. See "Printing the Printer Configuration Page" on page 13. If the controller recognizes the IPDS feature, the configuration page will list the IPDS menu and Installed options will list "IPDS." If IPDS is not listed, remove and reseat the IPDS SIMM. If reseating the SIMM does not correct the problem, replace the SIMM. 2. If you use either an Ethernet or Token Ring connection, make sure you are configured for TCP/IP. You cannot send IPDS jobs to the printer using an Ethernet or Token Ring card that is not configured for TCP/IP. See <i>IBM Network Printers: Ethernet and Token Ring Configuration Guide</i> for more information about configuring Ethernet and Token Ring cards. 3. If you use either an Ethernet or Token Ring connection, make sure the PERSONALTY item in the Token Ring Menu or the Ethernet Menu is set to AUTO or IPDS. AUTO allows the printer to handle any data stream; IPDS dedicates the card to IPDS jobs. If PERSONALTY is set to either PCL or PS (PostScript), you cannot print IPDS jobs using the card. 4. Make sure you have enough memory. See "Memory Requirements" on page 3.
Parallel attachment printing problems	<p>Make sure your printer driver is installed and connected to the correct port.</p> <p>Also, make sure you use properly shielded and grounded cables and connectors (IBM part number 63H2804 or its equivalent) that are no more than six feet (1.83 meters) in length.</p>

Symptom	Action
Poor quality shading patterns	<p>Shading patterns in your printed images are of poor quality.</p> <p>Response: Make sure the QUALITY item in the Config Menu is not set to REFINE. See “Configuration (Config) Menu” on page 81. Also make sure your printer driver or printer application is not specifying Edge Refinement. Values set in print jobs (either by the print application or the printer driver) override values you set at the printer.</p>
Any print quality problem	<p>The quality of the printed output is not acceptable. Examples of unacceptable output include light printing, streaks, splotches, random deletions, blank pages, and so on. See Appendix D, “Print Quality Problems” on page 213 for samples of print quality problems.</p> <p>Responses:</p> <ol style="list-style-type: none"> 1. Print a configuration page. See “Printing the Printer Configuration Page” on page 13. Verify that it has the same print quality problem. If not, suspect a problem with your job. 2. If printing is light, make sure QUALITY is not set to ECONO. Also, try increasing the DENSITY setting to a higher value. See “Configuration (Config) Menu” on page 81. 3. Make sure that the paper being used is fresh and dry and meets specifications. See “Selecting Paper and Other Printable Material” on page 22 for more information. 4. Install a new toner cartridge. Light prints may indicate that you need to replace the toner cartridge. See “Changing the Toner Cartridge” on page 111 for instructions on removing and replacing the toner cartridge. <p>If you cannot obtain a toner cartridge immediately, try the following:</p> <ul style="list-style-type: none"> • Remove the existing toner cartridge from the printer. • Grip it firmly, and turn it upside down a few times to spread the toner evenly along the distribution channel. • Reinstall the toner cartridge. <ol style="list-style-type: none"> 5. If the problem involves spots or streaks, print several test pages to clean out contamination. 6. If the problem is with complex graphics or images and the message MRT COMPRESSION displays, try changing the PAGEPROT menu item to ON. This item can be individually set in specific data stream menus (PCL Menu, PS Menu, or IPDS Menu.) You may need more memory SIMMs to invoke it. See “Memory Requirements” on page 3 for information about memory requirements. 7. If you have an EDGE-EDGE setting set to ON, set it to OFF. EDGE-EDGE can be found on the following menus: <ul style="list-style-type: none"> • “PCL Menu” on page 85 • “Coax Setup Menu” on page 98 • “Twinax Setup Menu” on page 100 • “IPDS Menu” on page 104 8. Consider replacing the usage kit. See “Changing the Usage Kit” on page 117.

Symptom	Action
Blank pages	<p>If all sheets are blank, the toner supply could be low but the toner sensor is not detecting this condition.</p> <p>Response: Replace the toner cartridge. See “Changing the Toner Cartridge” on page 111 for instructions on removing and replacing the toner cartridge.</p> <p>Random blank pages during a print job can be caused by multiple sheets of paper being fed through the machine simultaneously.</p> <p>Response: Reload the paper tray with fresh, dry paper. Fan the paper before loading it. If the problem still exists with the new toner cartridge installed, consider replacing the usage kit. See “Changing the Usage Kit” on page 117.</p>
Paper jams in the printer repeatedly	<p>Responses:</p> <ol style="list-style-type: none"> 1. Make sure that the paper tray guides are adjusted correctly for the size paper you are using. In particular, make sure the rear guides rest lightly against the back of the paper stack. Note that for some shorter paper sizes, only one guide adjusts to the back of the paper stack. 2. Do not refeed the same sheet of paper. 3. The paper you are using in the printer may not be compatible with your printer. Verify that the paper you are using conforms to the specifications for the printer. See “Selecting Paper and Other Printable Material” on page 22. 4. Check for obstructions in the paper path. Obstructions may include paper clips and corners of previously jammed paper. 5. Check the paper supply tray for damaged paper. 6. Reload the paper tray with fresh, dry paper. Fan the paper before loading it. 7. For duplex jams, ensure that the duplex unit is installed correctly. See “The Duplex Unit Option” on page 140. 8. For jams from the envelope feeder, check that the option is installed correctly. See “The Envelope Feeder Option” on page 174. Also check that the envelopes are loaded correctly, with the envelope stopper holding the edge. See “Loading Envelopes into the Envelope Feeder” on page 40. <p>See “Selecting Paper and Other Printable Material” on page 22 for more information.</p>
The printer takes too long to start printing	<p>The printer is frequently “warming up.”</p> <p>Response: Change the value for the power-saving mode (or sleep mode) to a larger value. See “Changing the Power Savings (Sleep Mode) Interval” on page 18 for instructions on how to change the setting.</p>

Symptom	Action
Test Menu items are not available	<p>If IPDS is the active data stream when the printer is taken offline, the following Test Menu items will not be available:</p> <ul style="list-style-type: none"> • CONFIG PAGE • PRINT PS FONTS • PRINT PCL FONTS • PRINT PS DEMO • PRINT SCS CHARS <p>These items reappear after a port timeout occurs (the length of the timeout depends on the host or network attachment you use); they also reappear if you power off the printer, wait ten seconds, and then power on.</p>
Problems printing in the 250-sheet tray	<p>Response: Make sure the paper is loaded correctly and that the paper guides are aligned correctly. (see "Loading Paper into the 250-Sheet Main Paper Tray (Tray 1)" on page 25).</p> <p>Note: Closing the 250-sheet tray with too much force can misalign the paper guides.</p>
Factory defaults did not get reset	<p>Invoking the FACTORY DEFAULT item on the Test Menu resets most values to the factory defaults. Some values do not get reset. These values include LANGUAGE, AUXSIZE, PCL SAVE, PS SAVE, BI-DI, IP ADDRESS, SUBNET MASK, GATEWAY ADDRESS, and MAC ADDRESS.</p> <p>Response: To reset all values, do one of the following:</p> <ul style="list-style-type: none"> • For A4 paper: power the printer off and then power the printer on while simultaneously pressing the Cancel Print key. • For Letter paper: power the printer off and then power the printer on while simultaneously pressing the Online key.
Problems with pre-printed forms	<p>Response: Allow 5 mm between printed information and pre-printed lines, cuts, or perforations on the pre-printed forms.</p>

Appendix B. Printer Messages

This chapter lists printer messages. Printer status messages are listed alphabetically in the next section, "Status Messages." Error messages are preceded by a number; see "Error Messages" on page 196.

Status Messages

BINS OPEN

Meaning: The Mailbox bins are open. No password is required.

Action: None required.

CLOSE BIN nn

Meaning: Mailbox bin nn is open.

Action: Close the bin.

COLD RESET A4

Meaning: The printer is powering up and resetting its defaults from a cold start. A4 size paper is the default paper size.

Action: None required; however, you need to restore any unique settings for the printer (such as default trays or bins).

COLD RESET LTR

Meaning: The printer is powering up and resetting its defaults from a cold start. Letter size paper is the default paper size.

Action: None required; however, you need to restore any unique settings for the printer (such as default trays or bins).

CONTEXT SAVE ADJUSTED

Meaning: The printer is configured to use the context saving option (PCL SAVE and PS SAVE under the Memconfig Menu); however, due to a configuration change, the printer no longer has enough memory to support context saving.

Action: None required. To restore context saving, add more memory to the printer. See "Memory Requirements" on page 3 for more information.

CONTEXT SAVE CHANGE

Meaning: The values for the PCL SAVE or PS SAVE items under the Memconfig menu have been changed.

Action: Press the **Continue/Enter** key to accept the new values and continue printing.

+ FORMAT DISK/- IGNORE DISK

Meaning: You are powering up with an unformatted hard drive, or you selected the FORMAT DISK action on the Test Menu.

Action: Press the **Value** key to format the disk. Press the **Shift** and **Value** keys simultaneously to continue as if there were no hard drive installed.

FLUSHING...

Meaning: The printer is canceling a PCL5e or PostScript job.

Action: None required.

FORMATTING

Meaning: The printer is formatting the hard drive.

Action: None required.

F/W xxxxxxx

Meaning: Unknown message (xxxxxxx can be any alphanumeric value).

Action: Power the printer off, wait ten seconds, and power the printer back on. If problems persist, call for technical support.

I/O INITIALIZING

Meaning: The network interface card is initializing.

Action: Normally none. If the message remains on the display and nothing prints, and (a) you have an Ethernet or Token Ring card, and (b) you are using letter or A4 size paper, make sure your LAN cable is connected and the network card is seated.

- IGNORE DISK/+ FORMAT DISK

Meaning: You are powering up with an unformatted hard drive, or you selected the FORMAT DISK action on the Test Menu.

Action: Press the **Value** key to format the disk. Press the **Shift** and **Value** keys simultaneously to continue as if there were no hard drive installed.

IPDS COAX

Meaning: The printer is receiving IPDS data through the coax interface.

Action: None required.

IPDS ETHERNET

Meaning: The printer is receiving IPDS data through the Ethernet interface.

Action: None required.

IPDS OPTION ERROR

Meaning: The printer has detected a problem in the IPDS module.

Action: Call for service.

IPDS TOKEN-RING

Meaning: The printer is receiving IPDS data through the token-ring interface.

Action: None required.

IPDS TWINAX

Meaning: The printer is receiving IPDS data through the twinax interface.

Action: None required.

KEY NOT VALID

Meaning: You pressed a key that is not valid.

Action: Press another key. In some instances, you may need to press the **Online** key to use other keys such as the **Menu** key.

MENU LOCKED

Meaning: The system administrator has locked the menu by issuing a PjL command from a print job. You cannot change values on this menu.

Action: None required.

MRT COMPRESSION ACTIVE

Meaning: The printer is compressing the page image it is currently printing.

Action: None required.

NEW VALUES AT NEXT BOUNDARY

Meaning: You have taken the printer offline while a job was printing in order to change a menu value. The new value might not take effect until the next "job boundary." Different data streams, in particular SCS, define job boundaries in different ways, so it may take a while for the new value to take effect.

Action: None required. If problems occur, make sure you take the printer offline to change menu values only when no jobs are printing (the printer is in Ready state).

NO BIN ACCESS WHEN IN MENUS

Meaning: You pressed the Mailbox button while in a menu.

Action: Press the **Online** key to leave the menu, then press the Mailbox button.

NONIPDS COAX

Meaning: The printer is receiving SCS or DSC/DSE data through the coax interface.

Action: None required.

NONIPDS TWINAX

Meaning: The printer is receiving SCS data through the twinax interface.

Action: None required.

OFFLINE

Meaning: The printer is offline.

Action: Press the **Online** key to make the printer active.

ONLINE HEX PRT

Meaning: The printer is performing a hexadecimal dump.

Action: None required.

OPEN BIN nn

Meaning: You can now open Mailbox bin nn.

Action: Open the bin.

PAGES:nnnn

Meaning: This is a response to the PAGE COUNT item on the Machine Info Menu, where nnnn is the number of pages the printer has printed.

Action: None required.

nn PASSWORD NOT VALID

Meaning: You entered a Mailbox bin password that is not valid.

Action: Enter a valid password.

PCL ETHERNET

Meaning: The printer is receiving PCL5e data through the Ethernet interface.

Action: None required.

PCL PARALLEL

Meaning: The printer is receiving PCL5e data through the parallel interface.

Action: None required.

PCL TOKEN-RING

Meaning: The printer is receiving PCL5e data through the token-ring interface.

Action: None required.

PLEASE WAIT

Meaning: The printer is processing data and cannot immediately respond to a request.

Action: Wait until the message clears. If the message remains and processing on the host appears to have stopped, power off the printer, wait ten seconds, and then power the printer on.

POWER SAVER ON

Meaning: The printer is in power-saving (sleep) mode and has temporarily shut off power to certain of its components. Power will be restored as soon as a job is submitted.

Action: None required.

PS PARALLEL

Meaning: The printer is receiving PostScript data through the parallel interface.

Action: None required.

PS TOKEN-RING

Meaning: The printer is receiving PostScript data through the token-ring interface.

Action: None required.

PS ETHERNET

Meaning: The printer is receiving PostScript data through the Ethernet interface.

Action: None required.

READY

Meaning: The printer is ready to receive data.

Action: None required.

RECONFIGURING MEMORY

Meaning: The printer has received a print job that requires it to adjust print settings for the current page.

Action: No action is required. The printer reconfigures its memory settings to print the current page. Afterward, its settings revert to normal. See “Memory Requirements” on page 3 for more information.

RESETTING PRINTER

Meaning: The printer is resetting to its default values.

Action: None required.

RESTORING DEFAULTS

Meaning: The printer is restoring the factory defaults for the printer.

Action: None required.

SWITCHING TO IPDS

Meaning: The printer is switching to IPDS.

Action: None required.

SWITCHING TO PCL

Meaning: The printer is switching to PCL5e.

Action: None required.

SWITCHING TO PS

Meaning: The printer is switching to PostScript.

Action: None required.

WARMING UP

Meaning: The printer is warming up. When it is warm, it displays the READY message.

Action: None required. If the message seems to appear too frequently, change the value for the power-saving mode (or sleep mode) to a larger value. See “Changing the Power Savings (Sleep Mode) Interval” on page 18 for instructions on how to change the setting.

Error Messages

The following error messages require operator intervention; they are listed numerically.

02 TONER LOW

Meaning: The toner in the printer cartridge is low.

Action: Check the next several pages of printed output. If the print quality is acceptable, press the **Continue/Enter** key to clear the message. Ensure that a new toner cartridge is available. When the print quality becomes unacceptable, install the new toner cartridge (see “Changing the Toner Cartridge” on page 111).

Note: If the print quality is unacceptable and you do not have a new toner cartridge, remove the old cartridge from the printer and gently rock it back and forth. This may temporarily improve the print quality of the old cartridge.

04 TONER CART MISSING

Meaning: The toner cartridge is either missing or is not in place.

Action: Open the printer and make sure the toner cartridge is seated correctly. If you have not installed a toner cartridge, do so now.

06 COVER OPEN

Meaning: The top or rear cover of the printer is open.

Action: Close the cover that is open.

11 LOAD paper_size IN tray

Meaning: The tray is out of paper or it contains the wrong size paper. The message identifies the size of paper (*paper_size*) and the tray (*tray*) that needs paper.

Action: If the tray is empty, refill it. The printer resumes printing on its own.

If the printer contains the wrong size paper, you have two choices: to use the current paper size, press the **Continue/Enter** key; otherwise, load the correct paper size into the bin.

12 LOAD paper_size IN MANUAL

Meaning: The auxiliary tray requires paper. The message indicates the required size (*paper_size*).

Action: Place another sheet of paper or other media in the auxiliary tray and press the **Continue/Enter** key. If you receive this message and you do not want to use the manual printing function, set MANUAL to OFF on the Paper Menu. See “Paper Menu” on page 77.

16 TRAY n MISSING

Meaning: The paper tray is not closed or installed.

Action: Open and close the tray. If you have not installed the tray, do so at this time.

17 option OPTION ERROR

Meaning: The option was detected previously, but is no longer detected.

Action: Make sure that the option is installed correctly.

18 MAILBOX POWER

Meaning: The Mailbox is not working.

Action: The most common cause of this error is powering on the printer before powering on the mailbox option. Switch the power off to both the printer and the mailbox. Then switch on power to the mailbox. Then switch on power to the printer.

20 PAPER JAM

Meaning: Paper has jammed while exiting the printer.

Action: See “20 PAPER JAM: Paper Exit Area” on page 58.

21 PAPER JAM

Meaning: Paper has jammed near one of the trays.

Action: See “21 PAPER JAM: Paper Tray Area” on page 60.

22 PAPER JAM

Meaning: Paper has jammed in the duplex unit.

Action: See “22 PAPER JAM: Duplex Unit Area” on page 63.

23 PAPER JAM

Meaning: Paper has jammed near the fuser.

Action: See “23 PAPER JAM: Toner Cartridge Area” on page 68.

24 PAPER JAM

Meaning: Paper has jammed in the 500-sheet Offset Paper Output.

Action: See “24 PAPER JAM: Offset Paper Output Bin” on page 70.

25 MAILBOX JAM

Meaning: Paper has jammed in the mailbox.

Action: See “25 PAPER JAM: Mailbox” on page 71.

29 OUTPUT FULL

Meaning: The output bin is full.

Action: Remove the output from the bin.

29 CHECK BIN MAILBOX nn

Meaning: A Mailbox bin is open or full.

Action: Close or empty the bin.

30 MEMORY OVERFLOW

Meaning: Memory overflow. The printer has received more data than it can fit into its memory.

Action: If the AUTOCONTINU item in the Config Menu is set to ON, printing resumes in thirty seconds. Otherwise, press the **Continue/Enter** key. Check the current page for errors. See “Memory Requirements” on page 3 for information on how much memory various options require.

31 MEMORY ALLOC ERROR

Meaning: The printer cannot allocate the memory required to print a job.

Action: If the AUTOCONTINU item in the Config Menu is set to ON, printing resumes in thirty seconds. Otherwise, press the **Continue/Enter** key. Check the current page for errors.

40 MEMORY OPTION ERROR

Meaning: A SIMM module is not properly seated in its slot or is in some other way defective.

Action: Turn off the printer. Pull out the controller card. Reseat the SIMM module. If the message recurs after you restart the printer, call for service.

41 NETWORK OPTION ERROR

Meaning: The printer detected a network interface card in the top slot, but the card is not communicating.

Action: Make sure the network card is properly installed and restart the printer. See "Installing a Network Interface Card" on page 136. If the message recurs, call for service.

42 NETWORK OPTION ERROR

Meaning: The printer detected a network interface card in the bottom slot, but the card is not communicating.

Action: Make sure the network card is properly installed and restart the printer. See "Installing a Network Interface Card" on page 136. If the message recurs, call for service.

43 PS OPTION ERROR

Meaning: The printer has detected a problem in the PostScript module.

Action: Reinstall the PostScript SIMM. See "Installing a SIMM" on page 130. If the message recurs, call for service.

44 IPDS OPTION ERROR

Meaning: The printer has detected a problem in the IPDS module.

Action: Reinstall the IPDS SIMM. See "Installing a SIMM" on page 130. If the message recurs, call for service.

45 OPTION ERROR

Meaning: The printer has detected a problem in either the IPDS SIMM or the PostScript SIMM.

Action: Reinstall the IPDS and PostScript SIMMs. See "Installing a SIMM" on page 130. If the message recurs, call for service.

46 NETWORK OPTION ERROR

Meaning: The printer has detected that two of the same network cards have been installed.

Action: Remove one of the cards.

47 attachment OPTION ERROR

Meaning: The indicated network interface card (*attachment*) is not communicating with the printer.

Action: Reseat the network interface card.

50 ERROR CALL FOR SERVICE

Meaning: The fuser is overheating.

Action: Turn off the printer for fifteen minutes and then turn on the printer. If the message recurs, call for service.

51 ERROR CALL FOR SERVICE

Meaning: A problem has occurred.

Action: Call for service.

52 ERROR CALL FOR SERVICE

Meaning: The printer has detected an error in the print mechanism.

Action: Call for service.

53 ERROR CALL FOR SERVICE

Meaning: The printer has detected a problem with the main motor.

Action: Call for service.

54 ERROR CALL FOR SERVICE

Meaning: The printer has detected a problem in the duplex unit.

Action: Make sure the duplex unit is installed correctly. Call for service if the problem continues.

55 ERROR CALL FOR SERVICE

Meaning: The printer has detected a problem with the fan.

Action: Call for service.

56 ERROR CALL FOR SERVICE

Meaning: The printer has detected an error in the engine NVRAM.

Action: Call for service.

57 ERROR CALL FOR SERVICE

Meaning: A problem has occurred.

Action: Call for service.

58 TRAY 1 ERROR CALL FOR SERVICE

Meaning: The printer cannot detect TRAY1.

Action: Call for service.

61 ERROR CALL FOR SERVICE

Meaning: The printer has detected an error in the ROM checksum.

Action: Call for service.

62 ERROR CALL FOR SERVICE

Meaning: The printer has detected an error in the DRAM.

Action: Call for service.

63 ERROR CALL FOR SERVICE

Meaning: The printer has detected an error in the NVRAM (EEPROM).

Action: Call for service.

71 ERROR DISK

Meaning: The printer has detected a problem with the hard drive.

Action: Call for service.

72 ERROR DISK

Meaning: The printer has detected a problem with the hard drive.

Action: Call for service.

73 ERROR DISK

Meaning: The printer has detected a problem with the hard drive.

Action: Call for service.

80 ADD MEMORY FOR IPDS

Meaning: The printer requires more memory before it can process IPDS jobs.

Action: Install more memory. See "Memory Requirements" on page 3 for information about IPDS memory requirements. See "Installing a SIMM" on page 130 for information about installing memory SIMMs.

81 INSUFFICIENT MEMORY FOR IPDS

Meaning: The printer does not have enough memory to process IPDS jobs.

Action: Power off the printer, wait twenty seconds, and then power on the printer to clear memory. If the error happens again, you may need to install more memory. See "Memory Requirements" on page 3 for information about IPDS memory requirements. See "Installing a SIMM" on page 130 for information about installing memory SIMMs.

82 HOST TIMEOUT

Meaning: The coax network interface card has sent an Intervention Required message to the host. This error occurs when (a) the printer is OFFLINE for longer than the HLD TMEOUT setting in the Coax Setup Menu, or (b) the printer has been in an intervention required state (such as out of paper) for longer than the IRQ TMEOUT setting.

Action: Solve the problem that caused the message (for example, press the **ONLINE** key to put the printer online, or add paper). To disable this error message, set the HLD TMEOUT and IRQ TMEOUT values in the Coax Setup Menu to 0.

83 CX SEND STATE

Meaning: Your coax host has placed your printer in "Send State" and is waiting for the printer to return a PA signal.

Action: Press the **Continue/Enter** key to clear the message. (You may need to press the key more than once.) Then do the following to send the PA signal.

1. Press the **Online** key to take the printer offline.
2. Press the **Menu** key until you see the Coax Setup Menu.
3. Press the **Item** key until you see PA1 or PA2 (whichever signal you want to send).
4. Press the **Continue/Enter** key to send the signal.
5. Press the **Online** key to resume printing.

Appendix C. Specifications and Repackaging

This chapter describes environmental and consumable information for purchasing of supplies. It also provides procedures for repackaging the printer for service or relocation.

Printer Specifications

Printing system	Electrophotography
Exposure system	Semiconductor laser beam scanning
Resolution	600 dpi
Warm-up time	Within 70 seconds after power on at 68 degrees F (20° C)
Low voltage	100–127 Volts, 50/60 Hz Power consumption Operating 330 watts (average) Standby 85 watts (average) Idle 30 watts (average)
High voltage	220–240 Volts, 50/60 Hz Power consumption Operating 340 watts (average) Standby 85 watts (average) Idle 25 watts (average)
Noise level	Operating: 49.5 dBA Idle: 32 dBA
Temperature	Shipping: –20° to 40° C (–4° to 104° F)
Humidity	Shipping and storage: 15 to 85% Note: The shipping and storage humidity can be between 5 to 15% or 85 to 95% for a maximum of 48 hours only. Operating and powered off: 15 to 85%
Dimensions	Basic (with tray extended to legal size): Width 442 mm (17.4 in.) Depth 468 mm (18.4 in.) Height 294 mm (11.6 in.) With trays extended to legal size, duplex unit, and 500-sheet output bin: Width 442 mm (17.4 in.) Depth 482 mm (19 in.) Height 664 mm (26.1 in.) With trays extended to legal size, duplex unit, and mailbox: Width 442 mm (17.4 in.) Depth 482 mm (19 in.) Height 904 mm (35.6 in.)

Clearance	<p>Front — 660 mm</p> <p>Sides — 200 mm</p> <p>Back — 450 mm</p>
Weight	<p>Basic (with tray extended to legal size):18.6 kg (40.9 lb.).</p> <p>With trays extended to legal size, duplex unit, and 500-sheet output bin: 30.5 kg (67.1 lb.).</p> <p>With trays extended to legal size, duplex unit, and mailbox: 37.1 kg (81.6 lb.).</p>

Cartridge Specifications

Temperature for Storage	0° to 40° C (0° to 104° F)
Humidity for storage	<p>15 to 85%</p> <p>Note: The shipping and storage humidity can be between 5 to 15% or 85 to 95% for a maximum of 48 hours only.</p>
Cartridge life	<p>10,000 images at 5% coverage on Letter-size paper. Depending on the type of printing you do, you can obtain double the page yield if you use the TonerMiser feature. For example, using the TonerMiser feature and a density setting of 3, you can expect an average cartridge life of 20,000 images at 5% coverage. To use the TonerMiser feature, you can set the Config Menu QUALITY setting to ECONO, or select toner saver print quality mode from your printer driver. (Note that the driver setting will override the menu setting.)</p>

Repackaging the Printer

Important!

If you intend to ship your printer for service or repairs, pack it in the original container. If you need a new shipping container, contact IBM technical support, or, in the U.S.A. and Canada, call 1-888-IBM-PRINT (1-888-426-7746).

Also, make sure you complete and return the Repair Inventory Worksheet with your printer. See "Repair Inventory Worksheet" on page 211.

Follow these procedures to repackage your printer for relocating or shipping.

1. Switch the printer power off.
2. Unplug the printer from the wall outlet.
3. Remove the power cord from the back of the printer.
4. Close the auxiliary tray.

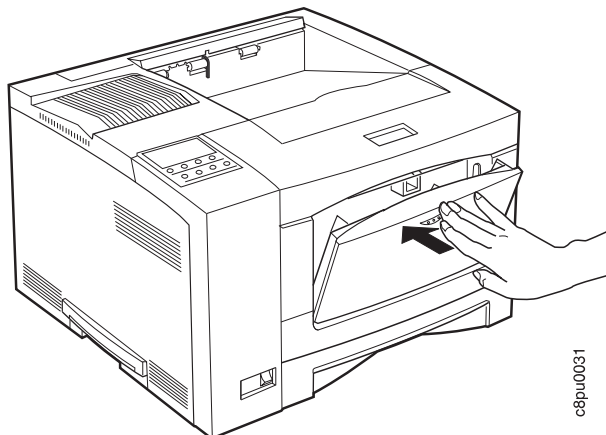

c8pu0031

5. Remove the following options from the printer (if installed):

- 500-sheet paper tray
- 250-sheet paper tray
- Offset paper output bin
- 10-bin mailbox
- Envelope feeder

6. Open the front cover and remove the toner cartridge.

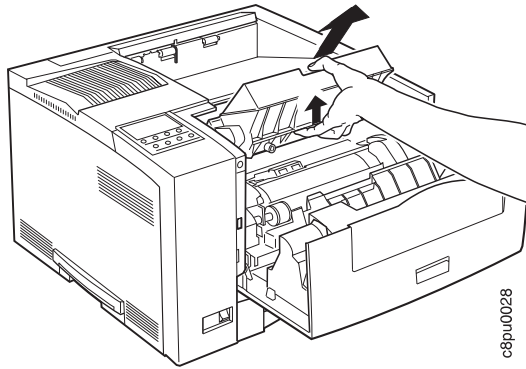

7. Place the toner cartridge inside a foil bag or the package that it came in. Keep the cartridge level during storage.

Note: Do not ship the toner cartridge with the printer.

8. Use the following steps to install the three orange/beige spacers at both ends of the transfer roller and to the left of the auxiliary tray pick roll at the locations shown by the arrows below:

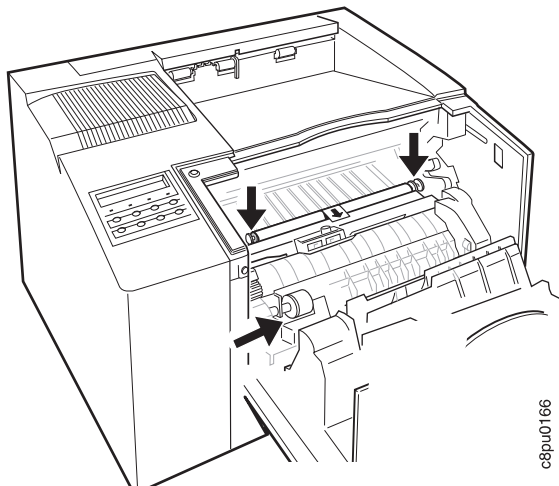

- a. Install the orange/beige spacer on top of the flanges at the left side of the transfer roller. Locate the “L” shaped upper portion of the spacer against the gray frame above the transfer roller. Pivot the spacer downward into place so that it clicks into place securely over the flange. Make sure the spacer is secure and that it holds the transfer roller stationary.

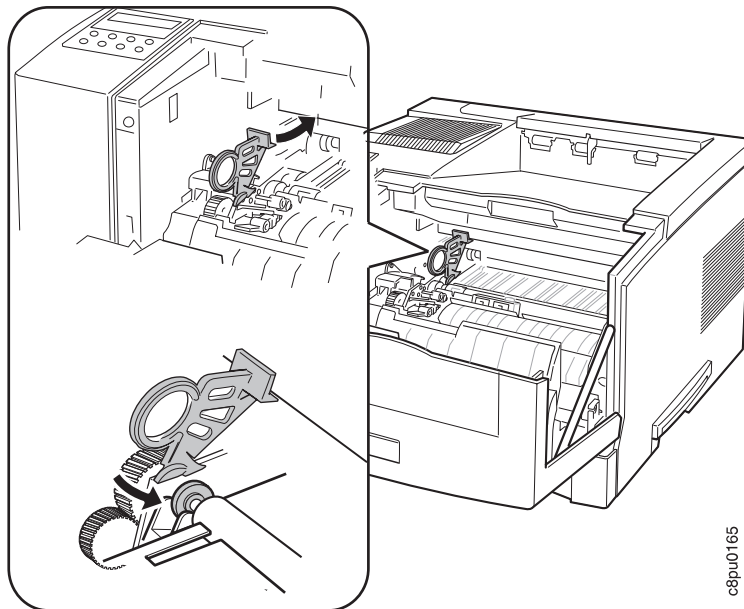

c8pu0165

- b. Install the orange/beige spacer on top of the flanges at the right side of the transfer roller. Repeat Step a for the right side transfer roller location.

- c. Install the flat orange/beige spacer to the left of the auxiliary tray pick roll so that the indented edge is secure against the bottom of the pick roll.

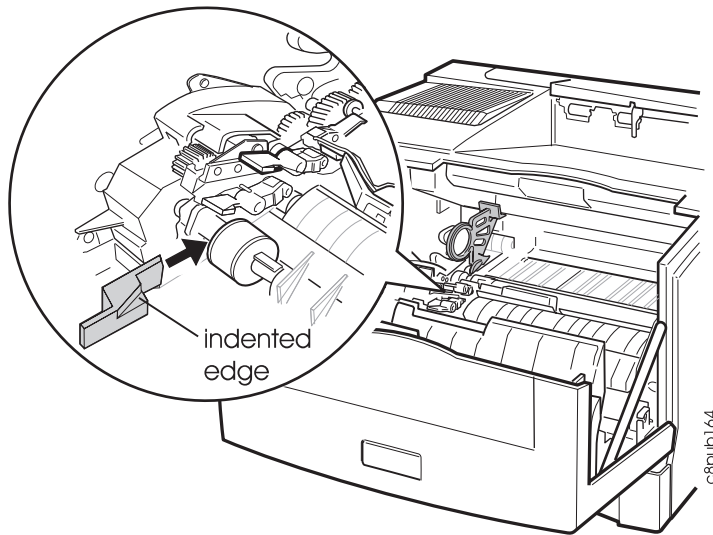

9. Remove all paper from the printer tray.
10. Press down on the bottom plate of the paper tray until it snaps into position. Insert the orange/beige spacer and place the tray back into the printer.

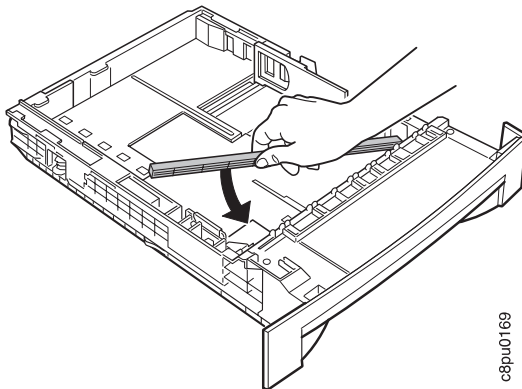

11. When you lift the printer, use the recessed grips located at the bottom of each side of the printer. Face the front of the printer to pick it up.

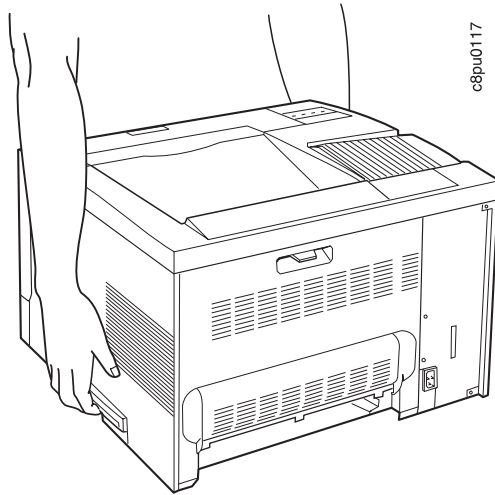

12. Place the printer back into its original packaging. Make sure to install the styrofoam packing shims as shown.

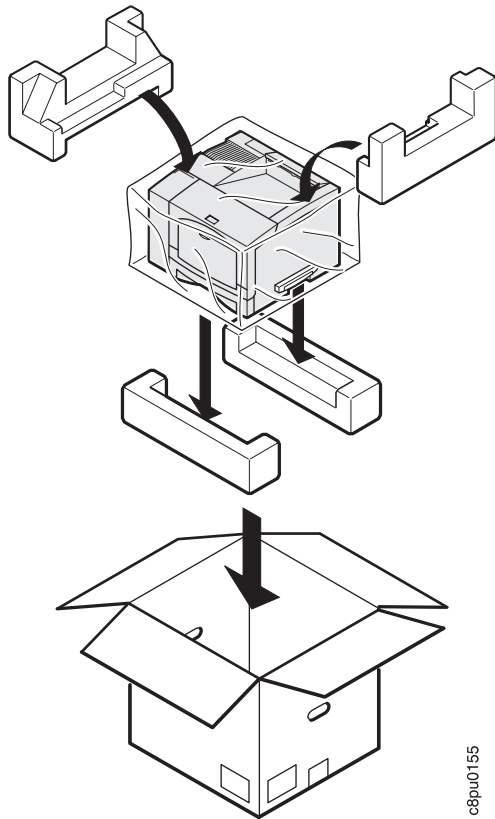

e8pu0155

13. Complete and include a copy of the Repair Inventory Worksheet with the printer. Make sure you note all of the printer options that are still installed on the printer. See "Repair Inventory Worksheet" on page 211.

Repair Inventory Worksheet

Important!

Please make a copy of this worksheet and include it with your printer if you need to ship your printer for repairs. Shipping your printer without this worksheet may delay repairs.

Customer Information

Customer name _____
Customer contact _____
Telephone _____
Machine type _____
Serial number _____

Inventory Checklist

Please check all of the options that you are returning with your printer.

- Duplex unit
- 500-sheet feeder
- 500-sheet feeder assembly
- 250-sheet paper tray
- 500-sheet paper tray
- 500-sheet offset catch tray
- 10-bin mailbox
- 75-envelope tray
- Token Ring NIC (network card)
- Ethernet NIC (network card)
- IPDS SIMM
- Coax card
- Twinax card
- Hard drive
- BASE PCL code SIMM
- 4MB DRAM
- 8MB DRAM
- 16MB DRAM
- 32MB DRAM
- 2MB Flash SIMM
- 4MB Flash SIMM
- Adobe PostScript SIMM

Appendix D. Print Quality Problems

Print Is Too Light

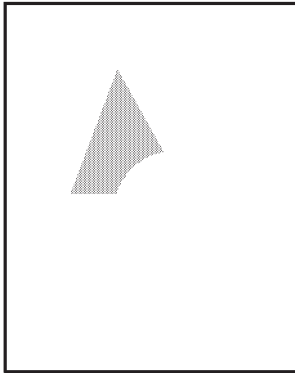
Possible Causes	Actions You Should Take	Print Sample
Economy mode is set on	Make sure economy mode is not set. See "Configuration (Config) Menu" on page 81.	
Density is set too low	Make sure that the density is not set to a value less than 6. Reset it to a higher value if necessary. See "Configuration (Config) Menu" on page 81.	
There is moisture in the paper	Load fresh, dry paper	
The toner cartridge is low on toner	Replace the toner cartridge with a new one	
The toner cartridge is damaged	Replace the toner cartridge with a new one	

Toner Spots on the Print

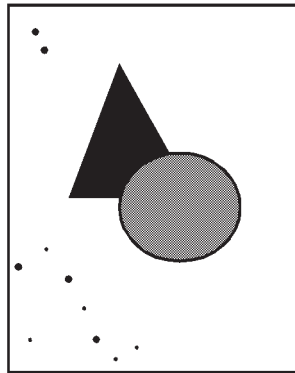
Possible Causes	Actions You Should Take	Print Sample
Paper does not meet specification	Use recommended paper	
The toner cartridge is damaged	Replace the toner cartridge with a new one	

Repetitive Marks on the Print

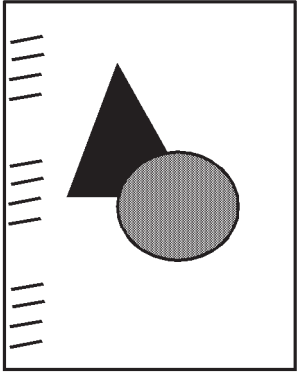
Possible Causes	Actions You Should Take	Print Sample
The paper path is contaminated	Print several blank sheets of paper to clear out the contamination	
The toner cartridge is damaged	Replace the toner cartridge with a new one	

Random Deletions or Light Areas on the Print

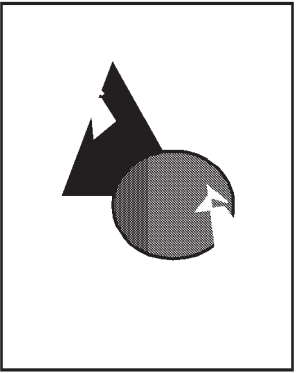
Possible Causes	Actions You Should Take	Print Sample
There is moisture in the paper	Load fresh, dry paper	
Paper does not meet specification	Use recommended paper	
The toner cartridge seal is still in place	Remove the toner cartridge seal	

Vertical Marks on the Print

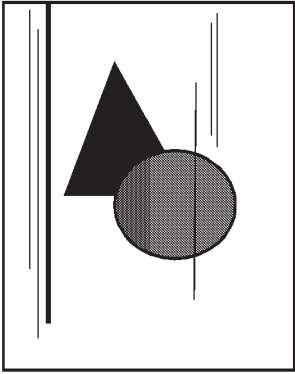
Possible Causes	Actions You Should Take	Print Sample
The toner cartridge is damaged	Replace the toner cartridge with a new one	 <p>The print sample shows a black triangle and a shaded circle. There are several thin, vertical white lines (marks) superimposed over the shapes, particularly on the left side of the triangle and the left side of the circle.</p>

Vertical Bands of Deletions or Light Areas on the Print

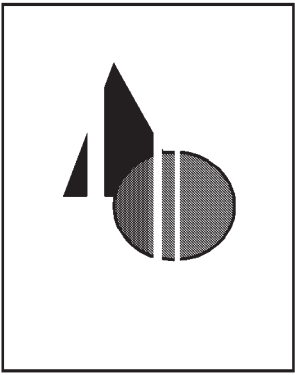
Possible Causes	Actions You Should Take	Print Sample
The toner cartridge is not installed correctly	Reinstall the toner cartridge	 <p>The print sample shows a black triangle and a shaded circle. There are vertical white bands (deletions or light areas) across the shapes, most notably a prominent vertical band through the center of the circle and the right side of the triangle.</p>
The toner cartridge is damaged	Replace the toner cartridge with a new one	

Entire Print is Black

Possible Causes	Actions You Should Take	Print Sample
The toner cartridge is damaged	Replace the toner cartridge with a new one	
The printer power supply has failed	Call for service	

Entire Print Is Blank

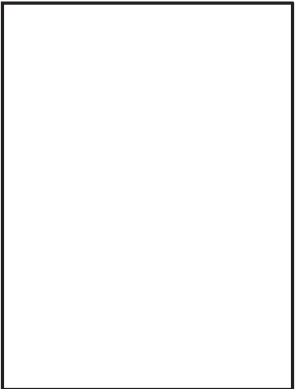
Possible Causes	Actions You Should Take	Print Sample
The toner cartridge seal is in place	Remove the toner cartridge seal	
There was a multiple sheet feed	Fan the paper	
The toner cartridge is low on toner	Replace the toner cartridge with a new one	
The toner cartridge is damaged	Replace the toner cartridge with a new one	
The printer power supply has failed	Call for service	

White Spots Within Black Image Area

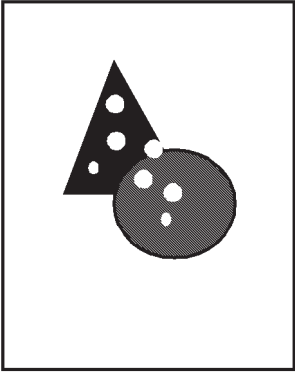
Possible Causes	Actions You Should Take	Print Sample
Paper does not meet specification	Use recommended paper	
The toner cartridge is damaged	Replace the toner cartridge with a new one	

Printed Image Rubs Off or Smears

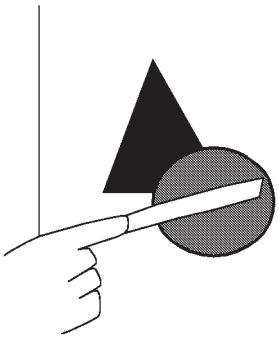
Possible Causes	Actions You Should Take	Print Sample
There is moisture in the paper	Load fresh, dry paper	
Paper does not meet specification	Use recommended paper	
The front cover is not fully closed	Close the front cover. Make sure the side latches are securely locked	
The fuser is not functioning properly	Consider replacing the usage kit. See "Changing the Usage Kit" on page 117	

The Print Is Damaged

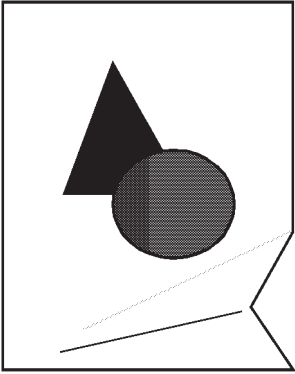
Possible Causes	Actions You Should Take	Print Sample
Paper does not meet specification	Use recommended paper	
There is excessive moisture in the paper	Load fresh, dry paper	
Damaged paper has been loaded in the paper tray	Load fresh, dry paper	

The Printed Image Is Blurred

Possible Causes	Actions You Should Take	Print Sample
Paper does not meet specification	Use recommended paper	
There is moisture in the paper	Load fresh, dry paper	

Glossary

The following terms are defined as they are used in Network Printer 17 documentation. If you do not find the term you need, refer to the index or to the *IBM Dictionary of Computing*, ZC20-1699 or the *IBM Dictionary of Printing*, G544-3973. A

A4-size paper. Paper that is 210 by 297 mm

A5-size paper. Paper that is 148.5 by 210 mm

A6-size paper. Postcard stock that is 105 by 148 mm

adhesive label. Special-application material; typically consists of paper labels coated on one side with an adhesive mixture temporarily affixed to backing material.

ASCII. American National Standard Code for Information Interchange. The standard code, using a coded character set consisting of 7-bit coded characters (8 bits including parity check), that is used for information interchange among data processing systems, data communication systems, and associated equipment. The ASCII set consists of control characters and graphic characters.

Autocontinue. A function activated in the Config Menu that determines if the printer should resume printing without waiting for operator responses to certain types of errors. Examples of the types of errors that use this function are insufficient memory to print a complex page or a request to load paper (where printing can continue using a different size of paper than was specified for the job).

auxiliary tray. The paper source on the front of the Network Printer 17 that can accept transparencies, paper-backed labels, envelopes, and card stock as well as paper. Its capacity is 100 sheets. A setting in the Paper Menu determines if paper is fed automatically or manually from the auxiliary tray.

B5-JIS size paper. Paper that is 182 mm by 257 mm (7.17 in. by 10.12 in.).

B5-ISO size paper. Paper that is 176 mm by 250 mm (6.93 in. by 9.84 in.).

beaconing. A signal repeatedly displayed on a Token Ring card when the card detects a problem.

binder holes. A series of holes or slots punched at set intervals that allows the form to be inserted in a loose-leaf or ring binder.

binding. An item in the Paper Menu that specifies, for duplex sheets, which edge should be used for binding. LONG binding assumes the sheets will be bound along the long edge of the paper, SHORT binding assumes the sheets will be bound along the short edge of the paper.

bitmapped font. A font in which each character is defined by a raster bitmap.

bond (paper). Paper formulated with at least 80% wood pulp. Bond-paper forms work best in the Network Printer 17.

buffer. A routine or storage used to compensate for a difference in rate of flow of data, or time of occurrence of events, when transferring data from one device to another.

character set. (1) A finite set of different characters that is complete for a given purpose; for example, the character set in ISO Standard 646, "7-bit Coded Character Set of Information Processing Interchange." (2) A group of characters used for a specific reason; for example, the set of characters a printer can print.

coated paper. Paper that has had a surface coating applied to produce smoothness.

coax attachment. A coaxial attachment to the System 370.

coaxial. A cable consisting of one conductor, usually a small copper tube or wire, within and insulated from another conductor of larger diameter, usually copper tubing or copper braid.

code page. A font library of hexadecimal identifiers to graphic characters.

configuration. (1) The arrangement of a computer system or network as defined by the nature, the number, and the chief characteristics of its functional units. More specifically, the term configuration may refer to a hardware configuration or a software configuration. (2) The devices and programs that make up a system, subsystem, or network.

connector. A means of establishing electrical flow.

cut-sheet paper. Paper that is cut into sheets.

data stream. (1) All data transmitted through a data channel in a single read or write operation. (2) A continuous stream of data elements being transmitted, or intended for transmission, in character or binary-digit form, using a defined format.

default. An alternative value, attribute, or option that is assumed when none has been specified.

diagnostic. Pertaining to the detection and isolation of errors in programs and faults in equipment.

disable. To make non-functional. Contrast with enable.

DRAM. Dynamic random-access memory.

dry ink. The material that forms the image on the paper. Synonymous with toner.

DSC. 3270 Information Display System data-stream compatibility.

DSE. Data switching exchange.

duplex printing. Printing on both sides of a sheet of paper. Synonym for two-sided printing. Contrast with simplex printing.

Ethernet. A 10-megabit baseband local area network that allows multiple stations to access the transmission medium at will without prior coordination, avoids contention by using carrier sense and deference, and resolves contention by using collision detection and transmission. Ethernet uses carrier sense multiple access with collision detection (CSMA/CD).

flash memory. A type of random-access storage that preserves its contents when power is removed from it.

folio. 8.5 x 13 in. paper. Also called Legal 13.

font. (1) A family or assortment of characters of a given size and style; for example, 9-point Bodoni modern. A font has a unique name and may have a registry number. (2) A font is data used to create an image of each graphic character; for example, a raster pattern.

format. (1) The arrangement or layout of data on a data medium. (2) The size, style, type of page, margins, printing requirements, and so on, of a printed page.

forms. The material on which output data is printed, such as paper or adhesive labels. See preprinted form.

forms path. The entire route that forms travel during processing. The forms path usually begins where the forms are loaded and ends at the stacker. Synonym for paper path.

fuse. To use heat and pressure to blend toner onto forms to make a permanent bond.

fuser. The assembly that bonds the toned image to the paper, using heat and pressure.

graphic. A symbol produced by a process such as handwriting, drawing, or printing. See also vector graphics.

graphic character. A character that is normally represented by a graphic, independent of code points or fonts. A graphic character is often in the form of a spatial arrangement of adjacent or connected strokes; for example, a letter or digit.

hard drive. A standalone disk drive that reads and writes data on rigid disks and can be attached to a port on the printer. Synonymous with fixed disk drive, hard disk drive.

Hewlett-Packard Printer Command Language (HP-PCL). A data stream used for printing on Hewlett-Packard laser printers and compatible printers.

host system. (1) The primary or controlling computer in a multiple-computer installation. (2) A computer used to prepare programs for use on another computer or on another data-processing system; for example, a computer used to compile, link edit, or test programs to be used on another system.

image. (1) A string of picture elements organized in scan lines to represent the contrasting portions of a picture. (2) A likeness or imitation of an object. (3) In this printer, an image comprises a string of pels organized in scan lines to represent the contrasting portions of a picture. The image may consist of any data stored as a raster pattern. The term image is interchangeable with impression and is printed on one side of a sheet of paper. See also impression.

impression. An implied or physical page. Used when calculating the reduction of printer output caused by switching the printer between duplex and simplex modes or upper and lower paper supplies. See also image.

Intelligent Printer Data Stream. An architected host-to-printer data stream that contains both data and controls defining how the data (text, image, graphics, and bar code) is to be presented. IPDS provides a device-independent interface for controlling and managing all-points addressable printers.

interface. A shared boundary. An interface might be a hardware component to link two devices or it might be a portion of storage or registers accessed by two or more computer programs.

IPDS. See Intelligent Printer Data Stream.

intervention. An unexpected condition that requires user intervention to clear it, for example, out of toner.

ISO sizes. Pertaining to a set of paper sizes selected from those standardized by the International Organization for Standardization (ISO) for use in data processing.

jam. In a printer, a condition where forms have become blocked or wedged in the forms path so the printer cannot operate.

JIS. Japanese Industry Standards. Used in reference to paper standards for size.

landscape orientation. Text and images that are printed parallel to the longer side of the forms. Contrast with portrait orientation.

laser (light amplification by stimulated emission of radiation). A device that emits a beam of coherent light.

legal-size paper. Paper that is 216 mm x 356 mm (8.5 in. x 14.0 in.).

letter-size paper. Paper that is 216 mm x 279 mm (8.5 in. x 11.0 in.).

logical page. The print on the page, such as composed text, graphics, and fonts within defined margins. See also page. Contrast with physical page.

MRT compression. Memory Reduction Technology algorithms to compress printed pages into smaller memory space.

network interface cards. Optional features that allow the printer to attach to computer networks. The printer can have up to two network interface cards installed, allowing it to communicate with two networks.

offline. Not connected to an installed and enabled attachment. Contrast with online.

offset stacking. The jogged stacking of output media in the output stacker so that jobs protrude from the balance of the stack to give physical identification.

online. Connected to an installed and enabled attachment. Contrast with offline.

orientation. The number of degrees an object is rotated relative to a reference; for example, the orientation of an overlay relative to the page point of origin. See also text orientation.

output bin. The part of the Network Printer 17 where the printed sheets are collected.

outline font. A font whose graphic character shapes are defined by mathematical equations rather than by raster patterns. Contrast with raster font.

overrun condition. Loss of data because a receiving device is unable to accept data at the rate it is transmitted.

page. A collection of information bound by the beginning page control and its associated end control. A page of printing is one side of a sheet of paper or form. See also logical page and physical page.

paper path. The entire route that forms travel while they are being processed. The paper path usually begins where the forms are loaded and ends at the stacker.

parallel port. An access point through which a computer transmits or receives data that consists of several bits sent simultaneously on separate wires.

PCL5e. Hewlett-Packard's Printer Command Language, a data stream used for printing.

pel (picture element). (1) An element of a raster pattern; a point where a toned area on the photoconductor may appear. (2) On an all-points-addressable output medium, each pel is an addressable unit. On a row-column addressable output medium, the only pel addressable is the beginning of a character cell.

physical page. The form on which the printer is printing, such as an 8-1/2 x 11-inch sheet of paper. See also page. Contrast with logical page.

pitch. A unit of measurement for the width of a printed character. It identifies the number of graphic characters per inch; for example, 10-pitch has ten graphic characters per inch. Uniformly spaced fonts are measured in pitches. Contrast with point.

point. A unit of measurement for describing type sizes. There are 12 points to a pica, about 72 points to an inch.

point of origin. The location of the first print position on a logical page. The point of origin is usually stated in terms of X and Y coordinates. The point of origin used by a printer can be affected by factors such as printable area and forms orientation.

portrait orientation. Pertaining to a display or hard copy with greater height than width. Contrast with landscape orientation.

PostScript. (1) A page description language with interactive graphics capabilities that was developed by Adobe Systems, Inc. (2) An interpretive programming language that describes the appearance of text, graphical shapes, and sampled images on a printed page by defining a print file format that is the interface between document composition applications and raster printing devices.

preprinted form. A sheet of forms containing a preprinted design of constant data with which variable data can be combined. See also forms.

Print-Error Marker (PEM). Small, black, rectangular marks that indicate incorrectly placed data in the valid printable area.

print position. The physical positions of the characters constituting a print line relative to the form.

print quality. The quality of printed output relative to existing standards and in comparison with jobs printed earlier.

print surface. The side of a form that receives the printed image.

raster. (1) In computer graphics, a predetermined pattern of lines that provides uniform coverage of a display space. (2) The coordinate grid that divides the display area of a display device. (3) In the Network Printer 17, an on/off pattern of electrostatic images produced by the laser print head under control of the character generator.

raster font. A font in which each character is defined by a raster bitmap.

raster pattern. A series of picture elements (pels) arranged in scan lines to form an image.

raster scan. A technique of generating or recording the elements of an image by a line-by-line sweep across the entire output medium.

resident font. Those font data sets that are resident within the printer. They usually reside on the printer disk media (diskette or hard disk). These font sets are usually commonly used fonts. Having them resident reduces font load time. These fonts may also be used during offline testing of the printer.

scalable font. A font whose graphic characters are represented by mathematical equations and can be sized to different heights.

SCS. See SNA character string.

SIMM. Single inline memory module.

simplex printing. Printing on one side of a sheet of paper. Contrast with duplex printing.

SNA character string. In SNA, a character string composed of EBCDIC controls, optionally intermixed with end-user data, that is carried within a request/response unit.

skew. Refers to the paper going through the paper path at a slight angle. This will cause the printing lines to not be aligned properly.

stacker. A device used to hold paper or forms that have been printed; the output device of a printer.

storage. (1) The retention of data in a storage device. (2) In word processing, a unit into which recorded text can be entered, in which it can be retained and processed, and from which it can be retrieved. (3) A device, or part of a device, that can retain data.

symbol set. In PCL5e, a particular assignment of hexadecimal identifiers to graphic characters.

text orientation. The position of text as a combination of print direction and baseline direction. See also orientation.

throughput. A measure of the amount of work performed by the printer over a period of time, for example, number of jobs per day.

token ring. A network with a ring topology that passes tokens from one attaching device to another, for example, the IBM Token-Ring Network.

toner. (1) In a document-printing machine, image-forming material used in electrostatic processes. (2) A supply item for the printer. The black powder used for printing images. Synonymous with dry ink.

toner density. The amount of toner dispersed over a specified area. Higher toner density yields darker print; lower toner density produces lighter print.

trailing edge. The trailing edge of the paper is the edge of the paper that proceeds into the printer last as it is fed from one of the paper supplies.

twinax attachment. A twinaxial attachment to the AS/400.

twinaxial. A cable consisting of two conductors, usually small copper tubes or wires insulated from each other, within and insulated from another conductor of larger

diameter, usually copper tubing or copper braid. This type of cable is often used to attach printers to an AS/400 system.

two-sided printing. Printing on both sides of a sheet of paper. Synonymous with duplex printing. Contrast with simplex printing.

valid printable area. The area represented by the intersection of the physical page and the current logical page. You can use the VPA CHK item on the IPDS Menu to specify if attempts to print outside this area cause errors to be reported to the host.

vector graphics. Computer graphics in which display images are generated from display commands and coordinate data. See also graphic. Contrast with raster pattern.

xerographic paper. A paper that is manufactured specifically for the xerographic process, in which key paper qualities are carefully controlled.

Index

Numerics

- 100-sheet auxiliary tray
 - See auxiliary tray
 - 250-sheet tray
 - adjusting paper size 26
 - guidelines for selecting paper 25
 - loading paper 25
 - location 1
 - 500-sheet tray
 - adjusting paper size 38
 - guidelines for selecting paper 36
 - installing 144
 - loading paper 36
 - location 1
 - paper supported 144
 - removing 156
 - stacking two 147
- ### A
- A4-size paper
 - See paper
 - A5-size paper
 - See paper
 - Acrobat PDF files, Adobe 6
 - address
 - gateway address, changing 180
 - IP address, changing 180
 - IPDS port, setting for twinax 101
 - locally administered MAC address, changing 181
 - SCS port, setting for twinax 100
 - subnet mask, changing 180
 - adjusting
 - 250-sheet tray paper size 26
 - 500-sheet tray paper size 38
 - auxiliary tray paper size 31
 - envelope sizes 43
 - Adobe Acrobat PDF files, obtaining 6
 - APO
 - Coax SCS Menu item 94
 - Twinax SCS Menu item 97
 - Attention indicator light 8
 - AUTO FUNCTION, Coax DSC/DSE Menu item 103
 - AUTOCONTINU, Config Menu item 81
 - autocontinue function 81

- automatic print orientation
 - coax SCS 94
 - twinax SCS 97
- AUX
 - Coax SCS Menu item 93
 - Paper Menu item 78
 - Twinax SCS Menu item 96
- auxiliary tray
 - adjusting paper size 31
 - defining paper size 54, 78
 - loading envelopes 32
 - loading paper 30
 - location 1
 - paper sizes supported 22
 - selecting as default 77
 - setting manual feeding on or off 78

B

- B5-size paper
 - See paper
- BI-DI, Parallel Menu item 84
- bi-directional communications, parallel port 84
- BIN FULL, Mailbox Menu item 80
- BIN, Mailbox Menu item 80
- binding margins
 - left, coax 95
 - top, coax 95
- BINDING, Paper Menu item 78
- bins
 - clearing jams 70
 - location 1
 - output at wrong one 184
 - selecting default 53, 77
- blinking lights
 - See indicator lights
- boxes in message display area 183
- BUFFERSIZE
 - Coax Setup Menu item 99
 - Twinax Setup Menu item 101
- BUSY TMEOUT, Coax Setup Menu item 98
- buttons, operator panel
 - See keys, operator panel

C

- CANCEL CX HEX, Test Menu item 76
- CANCEL ONLN HEX, Test Menu item 76
- Cancel Print key 10
- CANCEL TX HEX, Test Menu item 76
- canceling print jobs 16
- card stock, selecting 22
- CASE, Coax SCS Menu item 94
- changing Mailbox bin passwords 51
- changing the usage kit 117
- changing toner 111
 - characters per inch
 - See CPI
- cleaning the printer 125
- clearance, printer 204
- clearing paper jams
 - duplex unit area 63
 - Mailbox 71
 - offset paper output bin 70
 - paper exit area 58
 - paper tray area 60
 - toner cartridge area 68
- coax attachment, installing 135
- Coax DSC/DSE Menu 102
- Coax SCS Menu 93
- Coax Setup Menu 98
- CODE PAGE
 - Coax SCS Menu item 95
 - Twinax SCS Menu item 97
- code pages
 - specifying for Coax SCS 95
 - specifying for IPDS 105
 - specifying for Twinax SCS 97
- CONFIG PAGE, Test Menu item 75
- Configuration (Config) Menu 81
- configuration page, printing 13
- configuring
 - coax 98
 - coax DSC/DSE 102
 - coax SCS 93
 - Ethernet attachment 91
 - IPDS defaults 104
 - paper settings 77
 - parallel attachment 84
 - PCL5e defaults 85
 - PostScript defaults 88
 - printer network addresses 179
 - printer settings 81
 - token-ring attachment 89

- configuring (*continued*)
 - twinax 100
 - twinax SCS 96
- contacting support 183
- context saving 4
- Continue indicator light 8
- Continue/Enter key 10
- CONTINUOUS TEST, Test Menu item 75
- controller card
 - inserting 134
 - installing 129
- COPIES
 - for PCL5e jobs 85
 - for PostScript jobs 88
 - PCL Menu item 85
 - PS Menu item 88
- CPI
 - Coax SCS Menu item 94
 - Twinax SCS Menu item 97
- CR AT MPP+1, Coax DSC/DSE Menu item 102
- CX HEX PRT, Test Menu item 76

D

- darker print, setting 18
- data stream
 - selecting for Ethernet attachment 91
 - selecting for parallel attachment 84
 - selecting for token ring attachment 89
- DEF CD PAG, IPDS Menu item 105
- DEF CPI, IPDS Menu item 105
- DEFAULT FGID, IPDS Menu item 105
- defaults, restoring 76
- density, changing toner 18
- DENSITY, Config Menu item 81
- dimensions, printer 203
- disabling Mailbox bin passwords 49
- downloading fonts and overlays using NPRU 5
- DRAM
 - installing 128
 - requirements 3
- drawers, paper
 - stacking 147
 - uncoupling 159
- drivers
 - See printer drivers
- dumps
 - coax 76
 - online 76
 - twinax 76

- duplex printing
 - duplex setting ignored 185
 - specifying layout (BINDING) 78
 - specifying the printer default 16, 55
 - turning on or off 79
- duplex unit
 - clearing jams 63
 - installing 140
 - paper supported 140
 - removing 142
- DUPLEX, Paper Menu item 79
- dynamic random access memory
 - See DRAM

E

- EAB, Coax Setup Menu item 99
- EARLY COMPL
 - Coax Setup Menu item 99
 - IPDS Menu item 108
- early print completion
 - coax 99
 - IPDS 108
- EDGE-EDGE
 - Coax Setup Menu item 99
 - IPDS Menu item 108
 - PCL Menu item 86
 - Twinax Setup Menu item 101
- ejecting stored PCL5e pages 16
- EMULATION, IPDS Menu item 105
- enabling Mailbox bin passwords 47
- entering passwords for Mailbox 45
- envelope feeder
 - envelopes supported 174
 - guidelines for selecting 40
 - installing 174
 - loading envelopes 40
 - location 1
 - removing 177
 - selecting as default 77
 - selecting envelope size 54, 78
 - sizes supported 22
- envelopes
 - adjusting size using Paper Menu 43
 - capacity 32
 - guidelines for selecting 32
 - loading 24
 - loading into auxiliary tray 32
 - selecting 22
 - selecting size 54, 78

- envelopes (*continued*)
 - size 32
 - supported for envelope feeder 174
 - weight 32
- environmental specifications 203
- ENVSIZE, Paper Menu item 78
- error log, displaying 109
- ERROR LOG, Machine Info Menu item 109
- errors
 - messages, complete listing 196
 - printing PostScript 88
 - setting autocontinue mode 81
- Ethernet
 - configuring network addresses 179
 - network card, installing 135
- Ethernet Menu 91
- executive-size paper
 - See paper
- extended attribute buffer, coax 99

F

- FACTORY DEFAULT, Test Menu item 76
- factory defaults, restoring 76
- features
 - optional 2
 - optional, installing 127
 - standard 1
- FF DATA, Coax DSC/DSE Menu item 103
- FF LAST, Coax DSC/DSE Menu item 103
- FF VALID, Coax DSC/DSE Menu item 103
- flash memory, installing 128
- FNTSRC, PCL Menu item 86
- folio-size paper
 - See paper
- FONT SUB, IPDS Menu item 108
- FONTNUM, PCL Menu item 86
- fonts
 - downloading using NPRU 5
 - IPDS list 75
 - IPDS resident default 105
 - IPDS substitution 108
 - PCL5e default (FONTNUM) 86
 - PCL5e list 75
 - PCL5e source (FNTSRC) 86
 - PostScript list 75
 - printing IPDS 17
 - printing PCL5e 17
 - printing PostScript 17
 - wrong type selected 185

form length for PCL5e jobs 86
FORM, PCL Menu item 86
FORMAT DISK, Test Menu item 76
formatting hard drive 76
frequent page jams 188
fuser
 installing new units 120
 removing used unit 117
 usage page count 109
FUSER CTR, Machine Info Menu item 109

G

GAA
 See MAC ADDRESS
GATEWAY ADDRESS
 Ethernet Menu item 92
 setting from operator panel 180
 Token Ring Menu item 90
getting more supplies 111
globally administered address
 See MAC ADDRESS
guidelines for envelopes 40

H

hard drive
 formatting 76
 installing 132
help line
 See technical support
help support, contacting 183
hex dumps 76
HLD TMEOUT, Coax Setup Menu item 98
humidity
 printer specification 203
 toner cartridge 204
humidity specification 203

I

indicator lights
 description of 8
input trays
 See trays
installing new fuser unit 120
installing new transfer roller 124
internet protocol address
 See IP ADDRESS

inventory worksheet 211
IP ADDRESS
 Ethernet Menu item 91
 setting from operator panel 180
 Token Ring Menu item 89

IPDS

buffer size, coax 99
buffer size, twinax 101
code page 105
default font 105
emulation mode 105
font list 75
IPDS Menu 104
memory requirements 3
page format 107
page protection 104
printing fonts list 17
printing problems 186
selecting for Ethernet attachment 91
selecting for token ring attachment 89
SIMM option, installing 128
twinax address 101
valid printable area checking 106
IPDS ADDR, Twinax Setup Menu item 101
IPDS Menu 104
IPDS PORT, IPDS Menu item 108
IRQ TMEOUT, Coax Setup Menu item 98
Item key 10

J

JAMRECOVERY, Config Menu item 81
jams
 See paper jams

K

keys, operator panel
 Cancel Print key 10
 Continue/Enter key 10
 Item key 10
 Menu key 10
 Online key 10
 Page Eject key 10
 Shift key 11
 Value key 11

L

LAA

See MAC ADDRESS

labels, selecting 22

landscape orientation for PCL5e 85

Language Menu 110

language, changing 19

layout, page

See orientation, page

LBM, Coax SCS Menu item 95

LEDs

See indicator lights

left margin, coax SCS 95

legal-size paper

See paper

letter-size paper

See paper

letterhead paper, loading 24

lighter print, setting 18

LINE SPACING, Coax SCS Menu item 94

line speed, setting for token ring network card 136

lines-per-inch

See LPI

lines-per-page for PCL5e jobs 86

loading

envelopes 24

envelopes into auxiliary tray 32

envelopes into envelope feeder 40

letterhead paper 24

paper 24

paper in 250-sheet tray 25

paper in auxiliary tray 30

paper into 500-sheet trays 36

prenumbered forms 24

preprinted paper 24

prepunched paper 24

locally administered MAC address

See MAC ADDRESS

lost pages 185

LPI

Coax SCS Menu item 94

Twinax SCS Menu item 96

M

MAC ADDRESS

Ethernet Menu item 92

setting from operator panel 181

Token Ring Menu item 90

Machine Information Menu 109

macros, downloading 5

Mailbox

changing bin passwords 51

clearing jams 71

disabling bin passwords 49

enabling bin passwords 47

installing 167

paper supported 167

removing 172

removing prints from bins 44

using 44

using password to access bins 45

Mailbox Menu 80

maintaining the printer 111

manual paper feeding from auxiliary tray 78

MANUAL, Paper Menu item 78

margins

left, coax SCS 95

top, coax SCS 95

maximum page length, coax SCS 94

maximum print position, coax SCS 94

memory

installing 128

requirements 3

Memory Configuration (Memconfig) Menu 83

Menu key 10

menus

changing language 19

Coax DSC/DSE Menu 102

Coax SCS Menu 93

Coax Setup Menu 98

Configuration (Config) Menu 81

Ethernet Menu 91

IPDS Menu 104

Language Menu 110

Machine Information Menu 109

Mailbox Menu 80

Memory Configuration (Memconfig) Menu 83

navigating 12

overview 73

Paper Menu 77

Parallel Menu 84

PCL Menu 85

PS Menu 88

Test Menu 75

Token Ring Menu 89

Twinax SCS Menu 96

Twinax Setup Menu 100

using 12

messages
 complete listing 191
 most common 9
misers (see QUALITY, Config Menu item) 82
MPL, Coax SCS Menu item 94
MPP, Coax SCS Menu item 94

N

navigating menus 12
network addresses, configuring 179
network interface card
 installing 136
 types supported 135
Network Printer Manager Utility 5
Network Printer Resource Utility 5
NL AT MPP+1, Coax DSC/DSE Menu item 103
noise specification 203
NPM
 See Network Printer Manager Utility
NPRU
 See Network Printer Resource Utility
numbering paper trays 79

O

obtaining supplies 111
Offset Paper Output Bin
 clearing jams 70
 installing 161
 location 1
 removing 165
offset tray, removing 165
ONLINE HEX PRINT, Test Menu item 76
Online indicator light 8
Online key 10
operator panel
 changing language 19
 common messages 9
 indicator lights 8
 keys 10
 location 1
 menu overview 73
 navigating menus 12
 overview 7
optional features, installing

 10-bin Mailbox 167
 500-sheet tray 144
 duplex unit 140
 envelope feeder 174
 hard drive 128
 installing 127
 network interface card 135
 offset output bin 161
 SIMMs 128
optional Mailbox feature
 See Mailbox
ordering supplies 111
orientation, page
 for coax SCS 93
 for PCL5e (landscape or portrait) 85
 for twinax SCS 96
ORIENTATION, PCL Menu item 85
output bins
 See bins
OUTPUT, Paper Menu item 77
overlays, downloading 5

P

PA1, Coax Setup Menu item 99
PA2, Coax Setup Menu item 99
packing the printer 205
page count, displaying 109
PAGE COUNT, Machine Info Menu item 109
Page Eject indicator light 8
Page Eject key 10
page length maximum, coax SCS 94
page orientation
 See orientation, page
page protection
 for IPDS jobs 104
 for PCL5e jobs 85
 for PostScript jobs 88
 memory requirements 3
PAGE, IPDS Menu item 107
PAGEPROT
 IPDS Menu item 104
 PCL Menu item 85
 PS Menu item 88
pages lost after jam 185
PAGESIZE, PCL Menu item 85
panel
 See operator panel
paper
 clearing jams 57
 loading 24
 loading into 250-sheet tray 25
 loading into 500-sheet tray 36

- paper (*continued*)
 - loading into auxiliary tray 30
 - orientation, portrait or landscape for PCL5e 85
 - selecting 22
 - sizes supported 22
 - sources 22
 - 100-sheet auxiliary tray 22
 - 250-sheet tray 22
 - 500-sheet tray 22
 - envelope feeder 22
 - selecting default 77
 - wrong one selected 185
 - supported for 500-sheet paper tray 144
 - supported for duplex unit 140
 - supported for mailbox 167
 - types not recommended for use 23
 - weights supported 22
 - wrong type selected 184
- paper jams
 - duplex unit area 63
 - frequent 188
 - Mailbox 71
 - offset paper output bin 70
 - pages lost 185
 - paper exit area 58
 - paper tray area 60
 - setting JAMRECOVERY mode 81
 - toner cartridge area 68
- Paper Menu 77
- paper output bin
 - See Offset Paper Output Bin
- parallel attachment printing problems 186
- Parallel Menu 84
- password
 - changing for Mailbox bins 51
 - disabling for Mailbox bins 49
 - enabling for Mailbox bins 47
 - using Mailbox 45
- PCL Menu 85
- PCL SAVE, Memconfig Menu item 83
- PCL5e
 - default font 86
 - default font point pitch 86
 - default font point size 86
 - default symbol set 87
 - edge-to-edge printing 86
 - font source 86
 - form length 86
 - memory requirements 3
 - page protection 85
- PCL5e (*continued*)
 - page size 85
 - PCL Menu 85
 - portrait or landscape 85
 - print copies 85
 - printing fonts list 17, 75
 - printing stored PCL5e pages 16
 - saving settings 83
 - selecting for Ethernet attachment 91
 - selecting for parallel attachment 84
 - selecting for token ring attachment 89
- PDF files, Adobe Acrobat 6
- PERSONALTY
 - Ethernet Menu item 91
 - Parallel Menu item 84
 - Token Ring Menu item 89
- PITCH, PCL Menu item 86
- pitch, PCL5e 86
- point size, PCL5e 86
- PORT TMEOUT
 - Coax Setup Menu item 98
 - Ethernet Menu item 91
 - Parallel Menu item 84
 - Token Ring Menu item 89
 - Twinax Setup Menu item 101
- portrait orientation for PCL5e 85
- PostScript
 - memory requirements 3
 - page protection 88
 - print copies 88
 - printing demo 75
 - printing errors 88
 - printing fonts list 17, 75
 - printing problems 186
 - PS Menu 88
 - saving settings 83
 - selecting for Ethernet attachment 91
 - selecting for parallel attachment 84
 - selecting for token ring attachment 89
 - SIMM option, installing 128
- power specification 203
- power-savings mode 81
- powersavings mode, changing 18
- prenumbered forms, loading 24
- preprinted paper, loading 24
- prepunched paper, loading 24
- PRINT ERRS, PS Menu item 88
- PRINT IMAGE, Coax DSC/DSE Menu item 102
- PRINT IPDS FONTS, Test Menu item 75

- PRINT PCL FONTS, Test Menu item 75
- print position (maximum), coax SCS 94
- PRINT PS DEMO, Test Menu item 75
- PRINT PS FONTS, Test Menu item 75
- print quality
 - entire print is black 216
 - entire print is blank 216
 - light areas on the print 214, 215
 - print is too light 213
 - printed image rubs off or smears 217
 - random deletions 214
 - repetitive marks on the print 214
 - setting from operator panel 82
 - solving problems 213
 - the print is damaged 218
 - the printed image is blurred 218
 - toner spots on the print 213
 - vertical bands of deletions 215
 - vertical marks on the print 215
 - white spots within black image area 217
- print resolution 203
- PRINT SCS CHARACTERS, Test Menu item 75
- printable area
 - defining for coax 99
 - defining for IPDS 108
 - defining for PCL5e 86
 - defining for twinax 101
- printer
 - cleaning 125
 - clearance 204
 - dimensions 203
 - optional features 2
 - repacking 205
 - selecting print materials 22
 - standard features 1
 - weight 204
- printer configuration page, printing 13
- printer drivers
 - obtaining 2
 - supported 2
 - using 2
- printer network card
 - See network interface card
- printer trays
 - See trays
- printing
 - coax dumps 76
 - configuration page 13
 - continuous test pages 75
 - duplex setting ignored 185

- printing (*continued*)
 - hex dumps for troubleshooting 76
 - IPDS fonts 17, 75
 - IPDS printing problems 186
 - pages after jams (JAMRECOVERY) 81
 - parallel attachment printing problems 186
 - PCL5e fonts 17, 75
 - PostScript fonts 17, 75
 - PostScript printing problems 186
 - printer configuration page 75
 - SCS characters 75
 - stored pages (PCL5e) 16
 - too slow 185
 - twinax dumps 76
 - wrong font selected 185
- problems, solving 183
- PS Menu 88
- PS2 SAVE, Memconfig Menu item 83
- PTSIZE, PCL Menu item 86
- purchasing supplies 111
- putting the printer away 205
- PWRSV, Config Menu item 81

Q

- QUALITY, Config Menu item 82

R

- rectangles in message display area 183
- recycled paper 22
- removing
 - 500-sheet tray 156
 - duplex unit 142
 - envelope feeder 177
 - fuser unit 117
 - mailbox 172
 - offset bin 165
 - toner cartridge 111
 - transfer roller 121
- renumbering paper trays 79
- repacking the printer 205
- repair inventory worksheet 211
- replacing
 - supplies 111
 - the transfer roller 120
- requirements, memory 3
- RESET PRINTER, Test Menu item 75
- resident IPDS font list 75

resolution 203
restoring factory defaults, restoring 76
returning the printer 205

S

SCS
 character list 75
 COAX SCS Menu 93
 Twinax SCS Menu 96
SCS ADDR, Twinax Setup Menu item 100
selecting paper 22
service clearance, printer 204
shading, quality problems 187
Shift key 10
shipping the printer 205
SIMM, installing 128
sleep, putting printer to 18
slow printing 185
SNMP 5
solving problems 183
SOURCE, Paper Menu item 77
specifications
 of printer (power, voltage, temperature,
 humidity) 203
 printer 203
 toner cartridge 204
stackers
 See bins
statement-size paper
 See paper
status indicators
 See indicator lights
status messages 191
stored pages (PCL5e), printing 16
stuck paper
 See paper jams
SUBNET MASK
 Ethernet Menu item 92
 setting from operator panel 180
 Token Ring Menu item 90
supplies
 number to call for ordering 111
 replacing 111
support, contacting 183
switching paper trays 55, 78
symbol set, PCL5e 87
SYMSET, PCL Menu item 87

T

TBM, Coax SCS Menu item 95
technical support
 information about 3
temperature specification 203
Test Menu 75
timeouts
 coax busy 98
 coax hold 98
 coax IRQ 98
 coax port 98
 Ethernet port 91
 parallel port 84
 token-ring port 89
 twinax port 101
token ring
 configuring network addresses 179
 network card, installing 135
 setting line speed for network card 136
Token Ring Menu 89
toner
 cartridge specification 203
 changing 111
 clearing jams from toner cartridge area 68
 counter 109
 density, changing 18
 misering 82
 setting density 81
 specifications 204
 usage page count 109
TONER CTR, Machine Info Menu item 109
TonerMiser (see QUALITY, Config Menu item) 82
top margin, coax SCS 95
transfer roller
 installing new roller 124
 removing used roller 121
 replacing 120
transparencies, selecting 22
TRAY RENUM, Paper Menu item 79
TRAY SWITCH, Paper Menu item 78
TRAY1
 adjusting paper size 38
 clearing jams 60
 Coax SCS Menu item 93
 loading paper 25
 location 1
 Twinax SCS Menu item 96
TRAY2
 adjusting paper size 38

TRAY2 (*continued*)

- clearing jams 60
- Coax SCS Menu item 93
- loading paper 36
- location 1
- selecting as default 77
- Twinax SCS Menu item 96

TRAY3

- adjusting paper size 38
- clearing jams 60
- Coax SCS Menu item 93
- loading paper 36
- location 1
- selecting as default 77
- Twinax SCS Menu item 96

trays

- printer default 53
 - renumbering (TRAY RENUM) 79
 - selecting default 77
 - switching 55, 78
- troubleshooting 183
- coax dumps 76
 - online hex dumps 76
 - twinax dumps 76
- tumble duplex (BINDING) 78
- twinax attachment, installing 135
- Twinax SCS Menu 96
- Twinax Setup Menu 100
- TX HEX PRT, Test Menu item 76

U

- usage kit
 - changing 117
- user keys
 - See keys, operator panel
- user panel
 - See operator panel
- using the Mailbox 44

V

- valid printable area checking, IPDS 106
- Value key 10
- voltage specification 203
- VPA CHK, IPDS Menu item 106

W

- weight, paper 22
- weight, printer 204
- worksheet, inventory repair 211
- wrong bin, output goes to 184
- wrong font 185
- wrong paper 184

X

- X-OFFSET, IPDS Menu item 106

Y

- Y-OFFSET, IPDS Menu item 106
- yield, toner 204

Readers' Comments — We'd Like to Hear from You

**IBM Network Printer 17
User's Guide**

Publication No. S544-5343-03

Use this form to provide comments about this publication, its organization, or subject matter. Understand that IBM may use the information any way it believes appropriate, without incurring any obligation to you. Your comments will be sent to the author's department for the appropriate action. Comments may be written in your language.

Note: IBM publications are not stocked at the location to which this form is addressed. Direct requests for publications or for assistance in using your IBM system, to your IBM representative or local IBM branch office.

	Yes	No
• Does the publication meet your needs?	_____	_____
• Did you find the information:		
Accurate?	_____	_____
Easy to read and understand?	_____	_____
Easy to retrieve?	_____	_____
Organized for convenient use?	_____	_____
Legible?	_____	_____
Complete?	_____	_____
Well illustrated?	_____	_____
Written for your technical level?	_____	_____
• Do you use this publication:		
As an introduction to the subject?	_____	_____
As a reference manual?	_____	_____
As an instructor in class?	_____	_____
As a student in class?	_____	_____
• What is your occupation?	_____	_____

Thank you for your input and cooperation.

Note: You may either send your comments by fax to 1-800-524-1519, or mail your comments. If mailed in the U.S.A., no postage stamp is necessary. For residents outside the U.S.A., your local IBM office or representative will forward your comments.

Comments:

Name

Address

Company or Organization

Phone No.

Readers' Comments — We'd Like to Hear from You
S544-5343-03



Cut or Fold
Along Line

Fold and Tape

Please do not staple

Fold and Tape



NO POSTAGE
NECESSARY
IF MAILED IN THE
UNITED STATES

BUSINESS REPLY MAIL

FIRST-CLASS MAIL PERMIT NO. 40 ARMONK, NEW YORK

POSTAGE WILL BE PAID BY ADDRESSEE

Information Development
The IBM Printing Systems Company
Department H7FE Building 003G
P O Box 1900
BOULDER CO 80301-9817

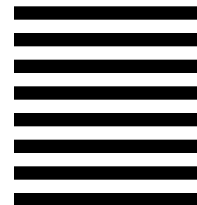

Fold and Tape

Please do not staple

Fold and Tape

S544-5343-03

Cut or Fold
Along Line



Part Number: 63H2495
File Number: S370/4300/9370-16

Printed in U.S.A.

S544-5343-03

