



SERVICE MANUAL

VHF FM TRANSCEIVERS

IC-F3021T
IC-F3022T
IC-F3023T
IC-F3021S
IC-F3022S
IC-F3023S

S-14303HZ-C1
July 2006

Icom Inc.

INTRODUCTION

This service manual describes the latest service information for the **IC-F3021T/S**, **IC-F3022T/S** and **IC-F3023T/S** VHF FM TRANSCEIVERS at the time of publication.

MODEL	Key Pad	VERSION	SYMBOL	Channel Spacing
IC-F3021T	10-key	U.S.A	[USA-02]	15.0 kHz / 30.0 kHz
IC-F3021S	4-key			
IC-F3022T	10-key	Europe	[EUR-02]	12.5 kHz / 20.0 kHz / 25.0 kHz
IC-F3022S	4-key			
IC-F3023T	10-key	General	[GEN-02]	12.5 kHz / 25.0 kHz
IC-F3023S	4-key			

To upgrade quality, any electrical or mechanical parts and internal circuits are subject to change without notice or obligation.

CAUTION

NEVER connect the transceiver to an AC outlet or to a DC power supply that uses more than 8 V. This will ruin the transceiver.

DO NOT expose the transceiver to rain, snow or any liquids.

DO NOT reverse the polarities of the power supply when connecting the transceiver.

DO NOT apply an RF signal of more than 20 dBm (100 mW) to the antenna connector. This could damage the transceiver's front end.

ORDERING PARTS

Be sure to include the following four points when ordering replacement parts:

1. 10-digit Icom parts numbers
2. Component name and informations
3. Equipment model name and unit name
4. Quantity required

<SAMPLE ORDER>

5030002760 LCD L3-0200HAY-3 IC-F3021T Main unit 5 pieces
8810009561 Screw PH BT M2 x 6 NI-ZK3 IC-F3021T Chassis 10 pieces

Addresses are provided on the inside back cover for your convenience.



REPAIR NOTES

1. Make sure a problem is internal before disassembling the transceiver.
2. **DO NOT** open the transceiver until the transceiver is disconnected from its power source.
3. **DO NOT** force any of the variable components. Turn them slowly and smoothly.
4. **DO NOT** short any circuits or electronic parts. An insulated turning tool **MUST** be used for all adjustments.
5. **DO NOT** keep power ON for a long time when the transceiver is defective.
6. **DO NOT** transmit power into a signal generator or a sweep generator.
7. **ALWAYS** connect a 40 dB to 50 dB attenuator between the transceiver and a deviation meter or spectrum analyzer when using such test equipment.
8. **READ** the instructions of test equipment thoroughly before connecting equipment to the transceiver.

Icom, Icom Inc. and ICOM logo are registered trademarks of Icom Incorporated (Japan) in the United States, the United Kingdom, Germany, France, Spain, Russia and/or other countries.

TABLE OF CONTENTS

SECTION 1	SPECIFICATIONS	
SECTION 2	INSIDE VIEWS	
SECTION 3	DISASSEMBLY INSTRUCTIONS	
SECTION 4	OPTIONAL UNIT INSTALLATION	
SECTION 5	CIRCUIT DESCRIPITON	
5-1	RECEIVER CIRCUITS	5-1
5-2	TRANSMITTER CIRCUITS	5-2
5-3	PLL CIRCUITS	5-4
5-4	DIGITAL CIRCUITS	5-5
5-5	POWER SUPPLY CIRCUITS	5-5
5-6	PORT ALLOCATIONS	5-5
SECTION 6	ADJUSTMENT PROCEDURES	
6-1	PREPARATION	6-1
6-2	FREQUENCY ADJUSTMENT	6-4
6-3	TRANSMIT ADJUSTMENT	6-5
6-4	RECEIVE ADJUSTMENT	6-6
SECTION 7	PARTS LIST	
SECTION 8	MECHANICAL PARTS AND DISASSEMBLY	
SECTION 9	SEMICONDUCTOR INFORMATION	
SECTION 10	BOARD LAYOUTS	
SECTION 11	BLOCK DIAGRAM	
SECTION 12	VOLTAGE DIAGRAM	
SECTION 13	BC-160	

SECTION 1 SPECIFICATIONS

			[USA], [GEN]	[EUR]	
GENERAL	• Frequency coverage		136–174 MHz		
	• Type of emission	Wide	16K0F3E (25.0 kHz)		
		Middle	–	14K0F3E (20.0 kHz)	
		Narrow	11K0F3E (12.5 kHz)	8K50F3E (12.5 kHz)	
	• Number of programable channels		128 channels (8 zones)		
	• Antenna impedance		50 Ω (nominal)		
	• Operating temperature range		–22°F to +140°F	–25°C to +55°C	
	• Power supply requirement		Specified Icom's battery packs only (Operatable voltage; 7.2 V DC negative ground)		
	• Current drain (approx.)	RX	Stand-by	75 mA	
			Max.audio	250 mA	
TX		at 5 W	1.5 A		
		at 1 W	0.7 A		
• Dimensions (projections not included)		2 ³ / ₃₂ (W) × 4 ²³ / ₃₂ (H) × 1 ⁹ / ₃₂ (D) in	53.0 (W) × 120.0 (H) × 32.5 (D) mm		
• Weight (with BP-231, approx.)		9.2 oz	260 g		
TRANSMITTER	• Transmit output power		5 W (High), 2 W (Low2), 1 W (Low1)		
	• Modulation		Variable reactance frequency modulation		
	• Max. permissible deviation	Wide	±5.0 kHz		
		Middle	–	±4.0 kHz	
		Narrow	±2.5 kHz		
	• Frequency error		±2.5 ppm	±1.5 kHz	
	• Spurious emission		80 dB typ.	0.25 μW (≤1 GHz), 1.0 μW (>1 GHz)	
	• Adjacent channel power	Wide	More than 70 dB (80 dB typ.)		
		Middle	–	More than 70 dB (80 dB typ.)	
		Narrow	More than 60 dB (70 dB typ.)		
	• Audio harmonic distortion		3% typ. (with 1 kHz AF 40% deviation)		
	• FM hum and noise (without CCITT filter)	Wide	More than 40 dB (46 dB typ.)	–	
		Narrow	More than 34 dB (40 dB typ.)	–	
	• Residual modulation (with CCITT filter)	Wide	–	More than 45 dB (53 dB typ.)	
Middle		–	More than 43 dB (51 dB typ.)		
Narrow		–	More than 40 dB (48 dB typ.)		
• Limiting charact of modulation		60–100% of max. deviation			
• Microphone impedance		2.2 kΩ			
RECEIVER	• Receive system		Double-conversion superheterodyne		
	• Intermediate frequencies		1st IF; 46.35 MHz, 2nd IF; 450 kHz		
	• Sensitivity		0.25 μV typ. at 12 dB SINAD	–4 dBμV (EMF) typ. at 20 dB SINAD	
	• Squelch sensitivity (at threshold)		0.25 μV typ.	–4 dBμV (EMF) typ.	
	• Adjacent channel selectivity	Wide	More than 70 dB (75 dB typ.)		
		Middle	–	More than 70 dB (75 dB typ.)	
		Narrow	More than 60 dB (65 dB typ.)		
	• Spurious response		More than 70 dB		
	• Intermodulation		More than 70 dB (75 dB typ.)	More than 65 dB (67 dB typ.)	
	• Audio output power		0.5 W typ. at 5% distortion with an 8 Ω load		
• Audio output impedance		8 Ω			

Measurements made in accordance with EIA-152-C/204D, TIA-603 ([USA], [GEN]) or EN 300 086 ([EUR]).

All stated specifications are subject to change without notice or obligation.

SECTION 2 INSIDE VIEWS

MAIN UNIT

TOP VIEW

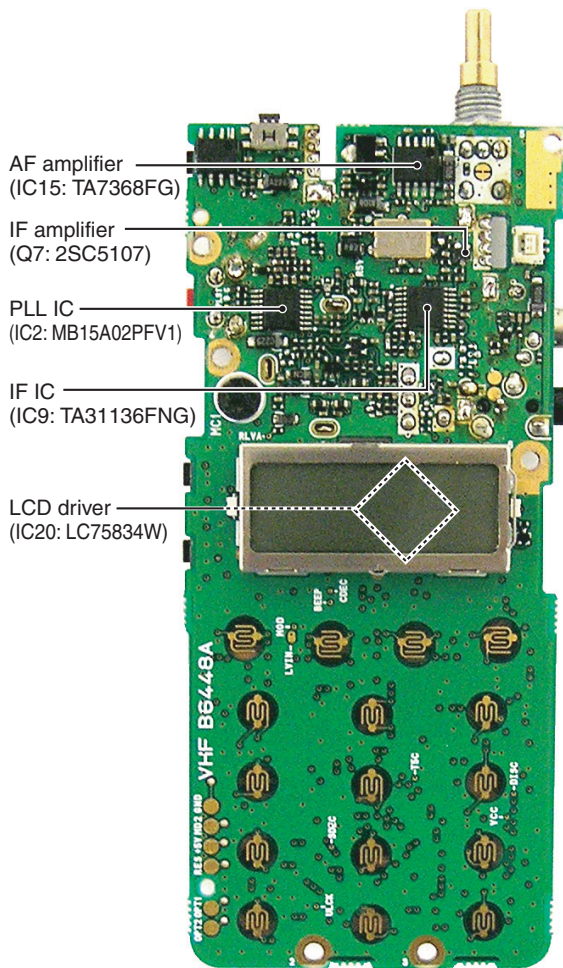

BOTTOM VIEW

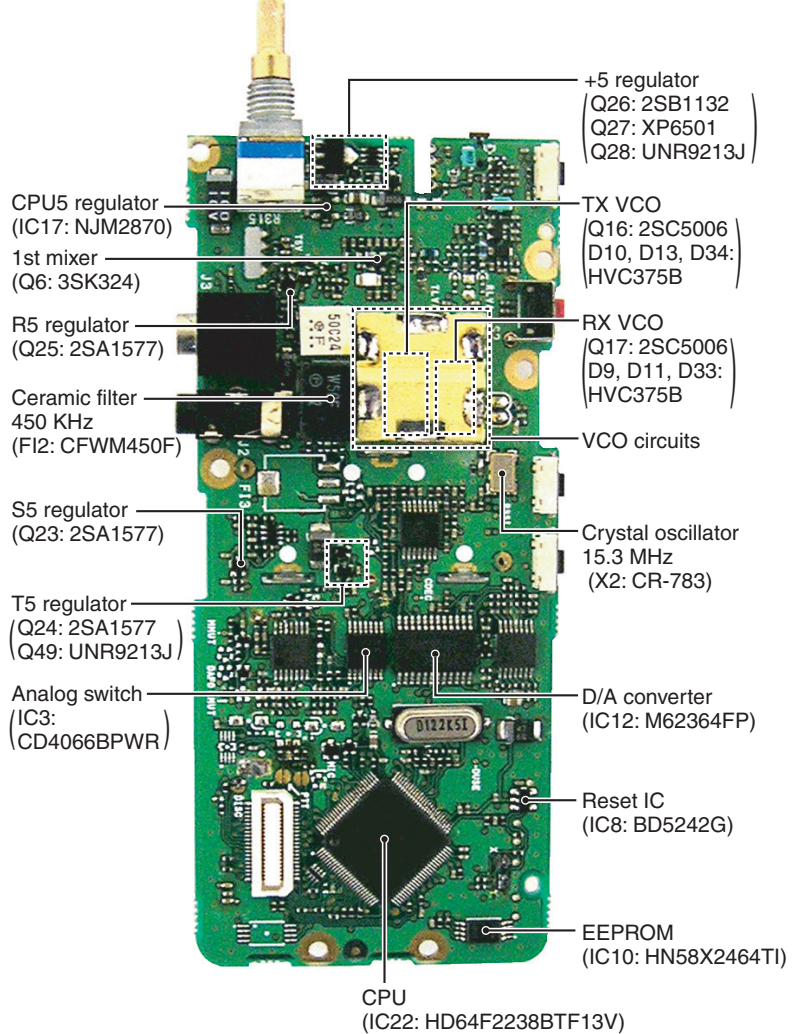

PA UNIT

TOP VIEW

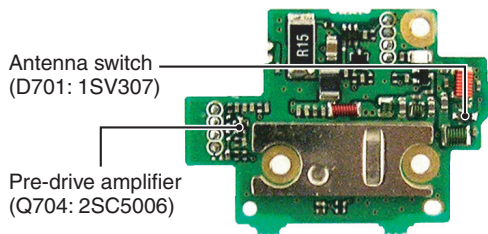

BOTTOM VIEW

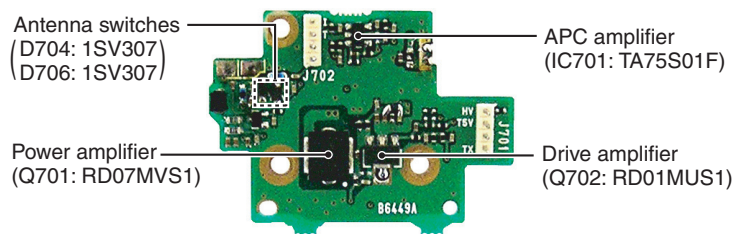

SECTION 3 DISASSEMBLY INSTRUCTIONS

1 REMOVING THE CHASSIS UNIT

- ① Unscrew ANT nut (A), and remove knob (B).
- ② Unscrew 2 screws (C), and remove the jack panel.
- ③ Unscrew 2 screws (D), and unplug the connector (E) from the chassis unit.
- ④ Take off the chassis unit in the direction of the arrow from the front panel.

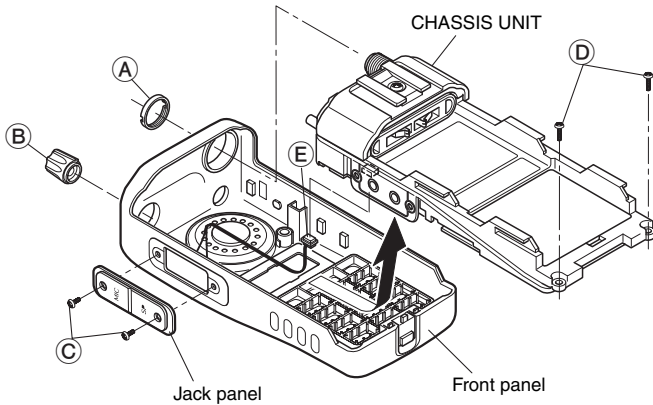

2 REMOVING THE MAIN UNIT

- ① Remove the main seal (F).
- ② Unscrew VR nut (G), and remove the top plate (H).

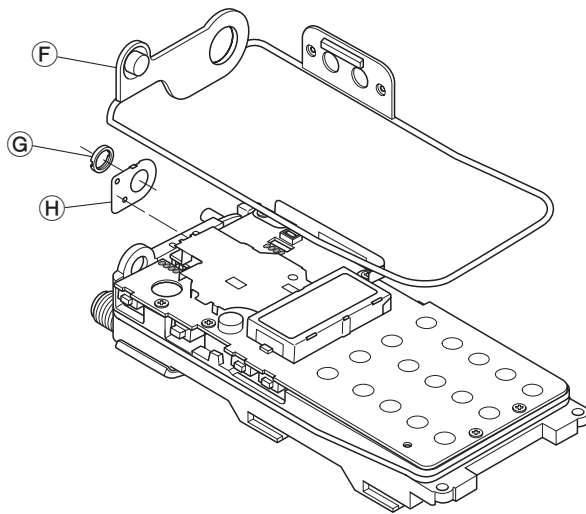

(Continued to right above)

- ③ Unscrew 6 screws (J).
- ④ Remove the side plate (I).
- ⑤ Unsolder 8 points (K), and remove the shield cover.
- ⑥ Unsolder 8 points (L), and take off the MAIN UNIT in the direction of the arrow.

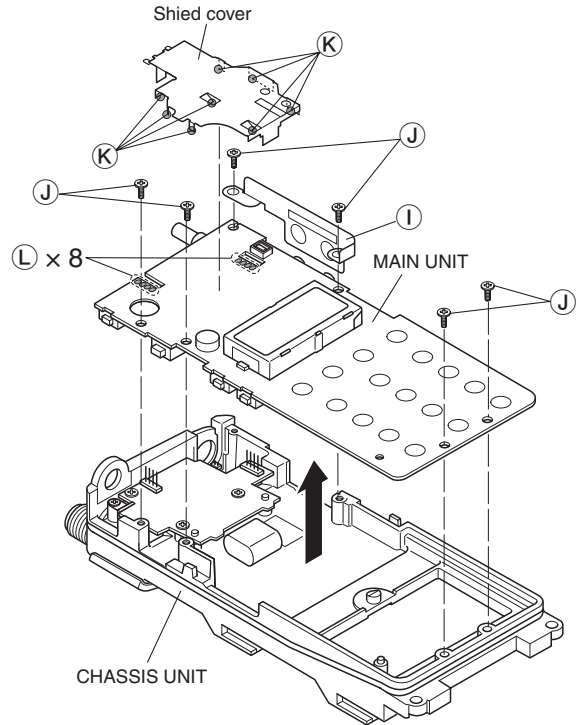

3 REMOVING THE PA UNIT

- ① Unscrew 3 screws (M).
- ② Unsolder 4 points (N), and take off the PA UNIT in the direction of the arrow.

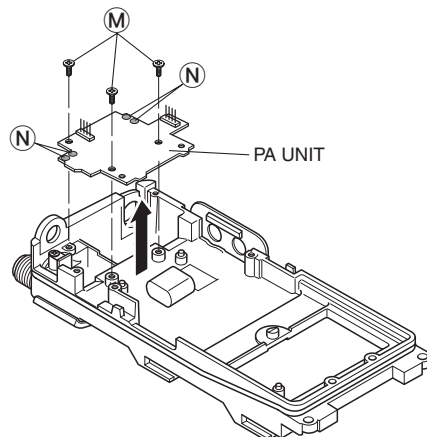

SECTION 4 OPTIONAL UNIT INSTALLATION

CAUTION! Optional unit installation should be done at authorized Icom service center only.

Install the optional unit as follows.

- ① Rotate [VOL] to turn the power OFF, and remove the battery pack.
- ② Remove the unit cover as below. (The removed unit cover can not be used again.)

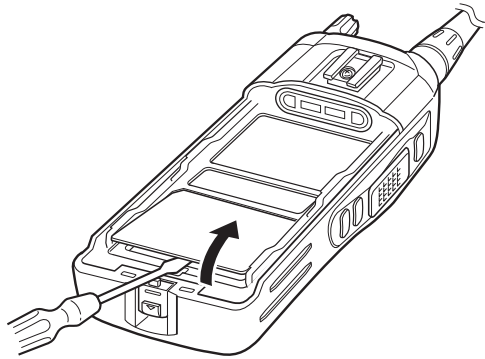

- ④ Install the unit as below.

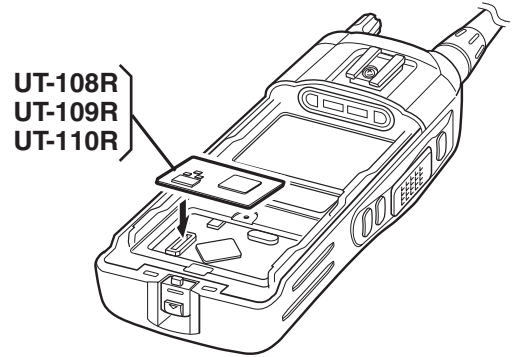

- ③ Cut the pattern on the PC board at "MIC" and "DISC" as below. (This modification is not necessary for UT-108R installation.)

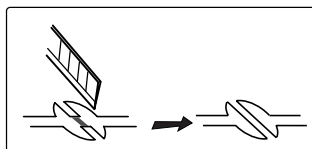
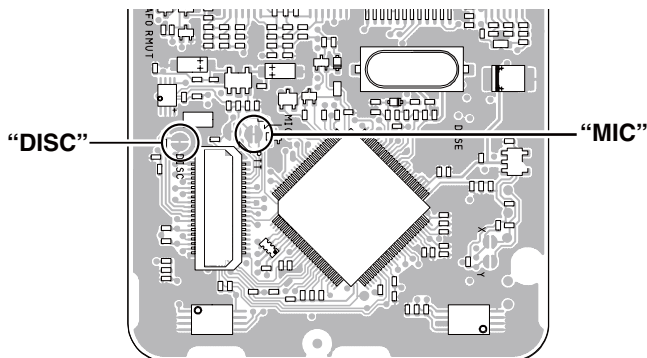

- ⑤ Remove the paper backing of the supplied unit cover, and attach the unit cover and the battery pack, then rotate [VOL] to turn the power ON.

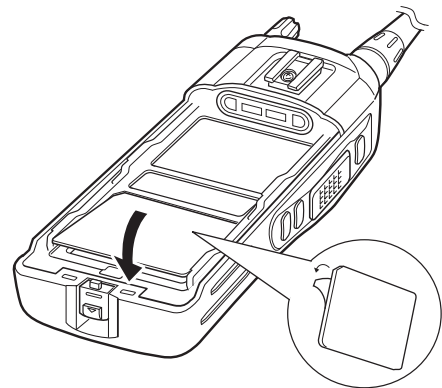

- ⑥ Set or modify the scrambler or decoder settings using optional CS-F3020.

NOTE: When uninstalling the unit

Be sure to re-solder the cut points as below when you remove the unit. Otherwise, no transmit modulation or receive AF output is available.

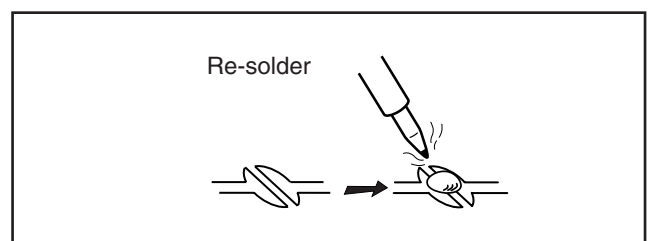

SECTION 5 CIRCUIT DESCRIPTION

5-1 RECEIVER CIRCUITS

5-1-1 ANTENNA SWITCHING CIRCUIT (PA UNIT)

The antenna switching circuit toggles the receive (RX) line and transmit (TX) line.

The received signals from the antenna are passed through the low-pass filter (ANT UNIT; L801, L802, C802, C803, C807) and antenna switch (D701, D704, D706).

While transmitting, the voltage on the T5V line is applied to D701, D704 and D706, and these are ON. Thus the TX line is connected to the antenna. Simultaneously, the RX line is connected to the ground (GND) to prevent transmit signal entering.

While receiving, no voltage is applied to the D701, D704 and D706, and these are OFF. Thus the TX line and the antenna are disconnected to prevent received signals entering. Simultaneously, the RX line is disconnected from the GND and the received signals are passed through the low-pass filter (L712, L714, C750, C751). The filtered signals are applied to the RF circuits.

5-1-2 RF CIRCUITS (MAIN UNIT)

RF circuits filter and amplify the received signals within the frequency coverage.

The received signals from the antenna switching circuit are passed through the two-staged bandpass filter (BPF; D19, D24, L7, L8, C22, C25, C27–C29, C369) to filter-out unwanted signals, and the filtered signals are applied to the RF amplifier (Q5). The amplified received signals are then applied to the 1st mixer (Q6) via another BPF (L47–L49, C19, C40, C437–C439, C443).

5-1-3 1st IF CIRCUITS (MAIN UNIT)

The received signals are converted into the 1st IF signal, filtered and amplified at the 1st IF circuits.

The received signals from the BPF (L47–L49, C19, C40, C437–C439, C443) are applied to the 1st mixer (Q6) and converted into the 46.35 MHz 1st IF signal by being mixed with the local oscillator (LO) signal from the RX VCO (Q17, D9, D11, D33).

The converted 1st IF signal is passed through the 1st IF filter (FI1) to filter-out adjacent signals, then applied to the 1st IF amplifier (Q7). The amplified 1st IF signal is then applied to the FM IF IC (IC9, pin 16).

5-1-4 2nd IF AND DEMODULATOR CIRCUITS (MAIN UNIT)

The 1st IF signal is converted into the 2nd IF signal, and demodulated.

The 1st IF signal from the 1st IF amplifier is applied to the 2nd mixer in the FM IF IC (IC9, pin 16), and converted into the 45.9 MHz 2nd IF signal by being mixed with the 45.9 MHz 2nd LO signal from the reference frequency oscillator (X2) via the tripler (Q22) and BPF (L33, C163, C164, C166). The converted 2nd IF signal is output from pin 3, and passed through the 2nd IF filters to remove sideband noise.

The 2nd IF signal is passed through the 2nd IF filter (FI2) and applied to the FM IF IC (IC9, pin 5) again. The filtered 2nd IF signal is amplified at the limiter amplifier, and FM-demodulated by the quadrature detector (IC9, pins 10, 11, X1). The demodulated AF signals are output from pin 9, then applied to the AF amplifier circuits.

5-1-5 AF AMPLIFIER CIRCUITS (MAIN UNIT)

The demodulated AF signals from the FM IF IC are amplified and filtered at AF circuits.

The demodulated AF signals from the FM IF IC (IC9, pin 9) are passed through high-pass filter (HPF; IC5, pins 2, 1) to remove tone signals. The filtered AF signals are passed through the de-emphasis circuit (R142, C249) to obtain the 6 dB/oct of frequency characteristic. The de-emphasized AF signals are passed through the RX mute switch (Q32, Q33), AF switch (Q36, Q37), HPF (IC5, pins 13, 14), analog switch (IC3, pins 1, 2), AF mixer (IC5, pins 6, 7) and analog switch (IC3, pins 10, 11) in sequence.

• 2nd IF AND DEMODULATOR CIRCUITS

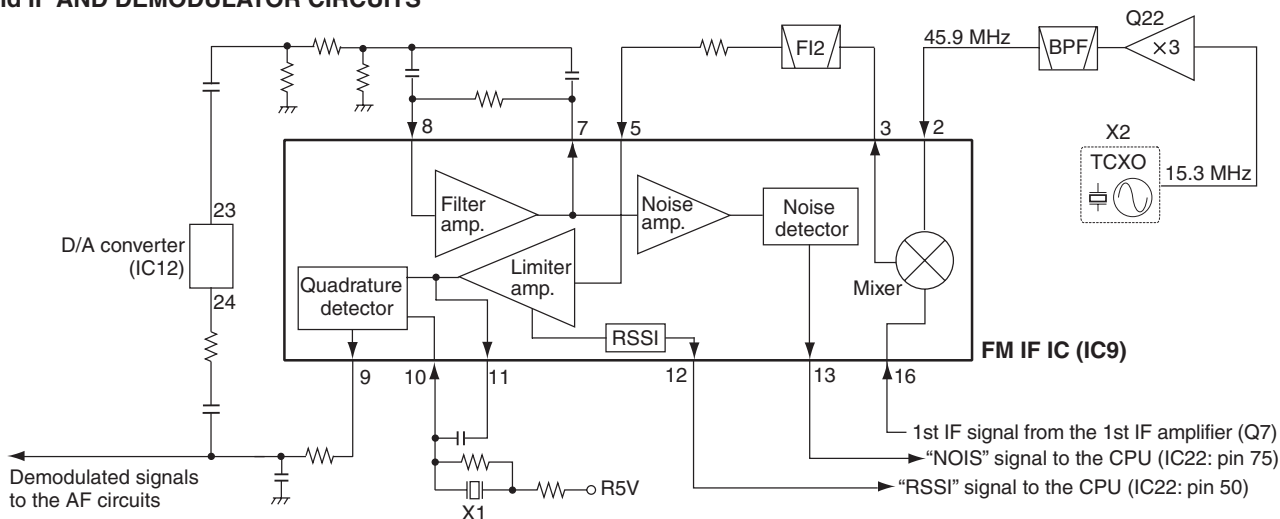

The AF signals from the analog switch (IC3, pin 11) are applied to the volume buffer amplifier (IC6, pin 9). The buffer-amplified AF signals are adjusted its level (= audio level) by volume control pot (R315), then applied to the AF power amplifier (IC15, pin 4) and amplified to the 0.5 W of audio output power (max., at 8 Ω load).

The power-amplified AF signals are output from pin 10, then applied to the internal speaker (CHASSIS; SP1) or an external speaker via [SP] jack (J2).

5-1-6 SQUELCH CIRCUITS (MAIN UNIT)

5-1-6-1 NOISE SQUELCH

The squelch mutes the AF output signals when no RF signal is received. By detecting noise components (around 30 kHz signals) in the demodulated AF signals, the squelch circuit toggles the mute switch and AF power amplifier ON and OFF.

A portion of the demodulated AF signals from the FM IF IC (IC9, pin 9) is applied to the D/A converter (IC12, pin 24) for level (= squelch threshold) adjustment. The level-adjusted AF signals are output from pin 23 and passed through the noise filter (IC9, pins 8, 7, R42, R44–R46, C69, C70, C413). The filtered noise signals are amplified the noise components only at the noise amplifier.

The amplified noise components are converted into the pulse-type signal at the noise detector section, and output from pin 13 as the “NOIS” signal. The converted signal is applied to the CPU (IC22, pin 75). Then the “RMUTE” signal from the CPU (IC22, pin 96) to the RX mute switch (Q32) and analog switch (IC3, pins 12, 13) becomes “Low” according to the “NOIS” signal level to cut off the AF line.

At the same time, the “AFON” signal from the CPU (IC22, pin 70) to the AF amplifier controller (Q41, Q42, D21, D23) becomes “Low” and the controller turns the AF power amplifier (IC15) OFF.

5-1-6-2 TONE SQUELCH

• CTCSS/DTCS

The tone squelch circuit detects tone signals and opens the squelch only when receiving a signal containing a matched sub audible tone. When the tone squelch is in use, and a signal with a mismatched or no sub audible tone is received, the tone squelch circuit mutes the AF signals even when the noise squelch is open.

A portion of the demodulated AF signals is passed through the active LPF (Q39) to filters CTCSS/DTCS signal. The filtered signal is applied to the CPU (IC22, pin 46). The CPU compares the applied signal and the set CTCSS/DTCS, then the CPU controls the status (“Low” or “High”) of “RMUTE” and “AFON” signals as same as “NOISE SQUELCH”.

• DTMF

DTMF signals in the demodulated AF signals are passed through the LPF (IC6, pins 5, 7) to remove unwanted components (voice signals), then applied to the CPU (IC22, pin 45) and decoded.

5-2 TRANSMITTER CIRCUITS

5-2-1 MICROPHONE AMPLIFIER CIRCUITS (MAIN UNIT)

The AF signals from the microphone (MIC signals) are filtered and level-adjusted at microphone amplifier circuits.

• MIC SIGNALS

MIC signals from the microphone are applied to or bypassed the ALC (Automatic Level Control) circuit (IC24, pins 3, 5) and the A/D switch (IC25, pins 7, 1), then applied to the D/A converter (IC12, pin 1).

The level-adjusted MIC signals are output from pin 2, and passed through the MIC mute switch (Q31), HPF (IC5, pins 13, 14) and gain switch (Q34) which controls the gain of MIC amplifier (IC5) according to the Analog/Digital mode, then applied to the MIC amplifier (IC5, pin 9). The amplified MIC signals are output from pin 8, and passed through the analog switch (IC3, pins 4, 3), AF mixer (IC5, pins 6, 7) where the MIC signals and tone signals are mixed with.

• TONE SIGNALS

The CTCSS/DTCS signals are generated by the CPU (IC22) and output from pins 19–21. The output signals are passed through the 3 resistors (R222–R224) to change its waveform. The waveform changed CTCSS/DTCS signals are passed through the LPF (IC7, pins 10, 8), tone filter switch (Q40) and D/A converter (IC12, pins 12, 11) for level adjustment. The level adjusted CTCSS/DTCS signals are then applied to the AF mixer (IC5, pin 6).

DTMF signals are generated by the CPU (IC22) and output from pin 43. The output DTMF signals are passed through two LPFs (IC6, pins 3, 1 and pins 12, 14), then applied to the AF mixer (IC5, pin 6).

The mixed AF signals are output from pin 7 of the AF mixer (IC5) and passed through the analog switch (IC3, pins 9, 8), then applied to the AF amplifier (IC7, pin 6). The amplified AF signals are output from pin 7, and applied to the D/A converter (IC12, pin 9) to be adjusted its level (= deviation). The level-adjusted MIC signals are then applied to the modulation circuits as the modulation signals.

5-2-2 MODULATION CIRCUITS (MAIN UNIT)

The modulation circuits modulate the VCO oscillating signal using the modulation signals.

The modulation signals from the D/A converter (IC12, pin 10) are applied to the D12 at the TX VCO (Q16, D10, D13, D34) to modulate the VCO oscillating signal by changing the reactance of D12.

The modulation signals are also applied to the reference frequency oscillator (X2) via D/A converter (IC12, pins 16, 15) and the buffer (IC7, pins 12, 14), to ensure the modulation of lower frequency components of the modulation signals.

The modulated VCO output is buffer-amplified by Q15 and Q29, then applied to the transmit amplifiers as the transmit signal via TX/RX switches (D16 is ON, D17 is OFF).

5-2-3 TRANSMIT AMPLIFIERS (PA UNIT)

The transmit signal from the VCO is amplified to the transmit output level by the transmit amplifiers.

The transmit signal from the TX/RX switches (MAIN UNIT; D16 is ON, D17 is OFF) is amplified by the pre-drive amplifier (Q704), drive amplifier (Q702) and power amplifier (Q701) in sequence to obtain 5 W (approx.) of transmit output power.

The power-amplified transmit signal is passed through the antenna switch (D701), then applied to the antenna via the LPF (ANT UNIT; L801, L802, C802, C803, C807).

5-2-4 APC CIRCUIT (PA UNIT)

The APC (Automatic Power Control) circuit prevents the transition of the transmit output power level which is caused by load mismatching or heat effect, etc.

A portion of transmit signal is detected by the transmit power detectors (D702, D703) to produce DC voltage corresponding to the transmit output power level. The detected voltage is applied to the APC amplifier (IC701, pin 3). The transmit power setting voltage "APC (T1)" from the D/A converter (MAIN UNIT; IC23, pin 1) is applied to another input terminal (pin 1) as the reference voltage.

The APC amplifier compares the detected voltage and reference voltage, and the difference of the voltage "APCV" is output from pin 4. The voltage "APCV" controls the bias of the pre-drive (Q704), drive (Q702) and power (Q701) amplifiers to reduce/increase the gain of these amplifiers for stable transmit output power.

The transmit power muting is carried out by the TX mute switch (MAIN UNIT; Q46), using the "TMUT" signal from the CPU (MAIN UNIT; IC22, pin 35).

5-2-5 OVER CURRENT DETECTION CIRCUIT (PA UNIT)

The driving current of the drive (Q702) and power (Q701) amplifiers is detected at the current detector (Q705, Q706) by detecting the difference of voltage between both terminals of R714. The detected voltage "ISENS" is applied to the CPU (MAIN UNIT; IC22, pin 47).

In case of the over current is detected, the CPU outputs "TMUT" signal from pin 35 to TX mute switch (MAIN UNIT; Q46) to stop the transmitting to protect the transmit amplifiers (Q701, Q702, Q704).

• APC CIRCUIT

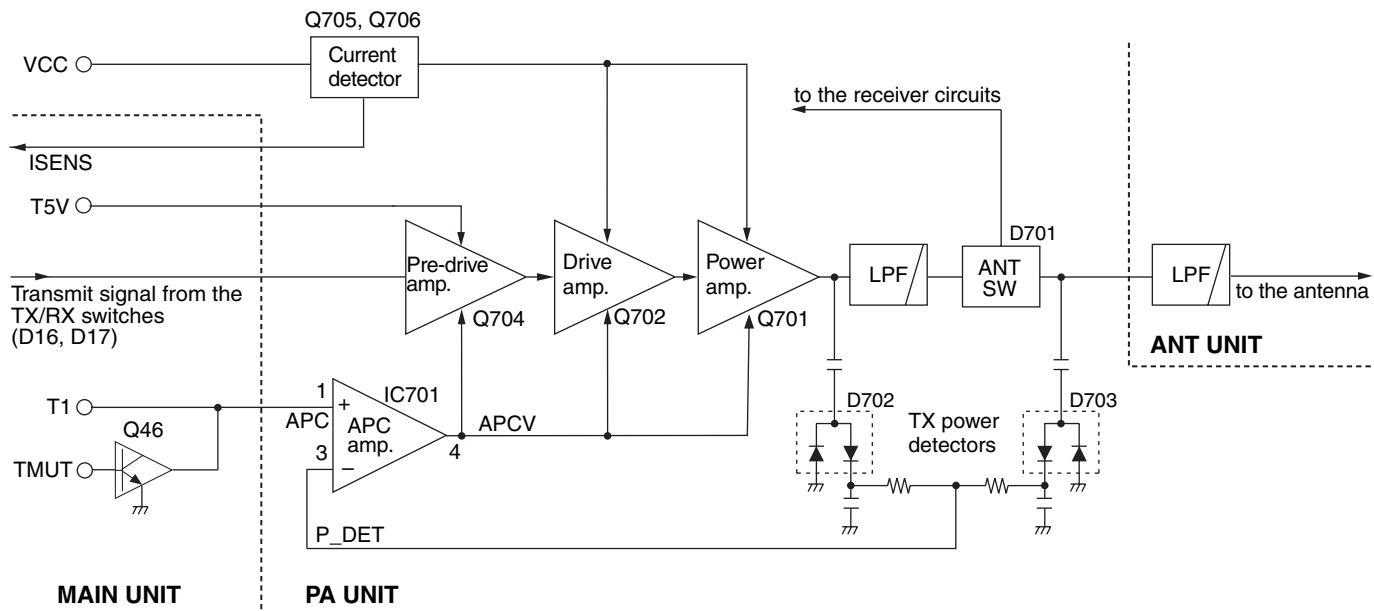

5-3 PLL CIRCUITS

5-3-1 VOLTAGE CONTROLLED OSCILLATORS (VCOs; MAIN UNIT)

VCO is an oscillator whose oscillating frequency is controlled by adding voltage (lock voltage).

This transceiver has 2 VCOs RX VCO (Q17, D9, D11, D33) and TX VCO (Q16, D10, D13, D34). The RX VCO oscillates the 1st LO signals, and the TX VCO oscillates the transmit signal.

• RX VCO

The output signals are amplified by the buffer amplifiers (Q15, Q29), and applied to the 1st mixer (Q6) via TX/RX switches (D16 is OFF, D17 is ON) and LPF (L46, C396, C397), to be mixed with the received signals to produce the 46.35 MHz 1st IF signal.

• TX VCO

The output signal is applied to the transmit amplifiers via the buffer amplifiers (Q15, Q29) and TX/RX switches (D16 is ON, D17 is OFF).

A portion of each VCO output is applied to the PLL IC (IC2, pin 8) via the buffer amplifier (Q15), doubler (Q14), BPF (D31, D32, L32, C196, C197, C199, C200, C205) and LPF (L34, L36, C202–C204).

5-3-2 PLL IC (MAIN UNIT)

The PLL circuit provides stable oscillation of the transmit frequency and receive 1st LO frequency. The PLL output frequency is controlled by the divided ratio (N-data) from the CPU.

The VCO output signal from the LPF (L34, L36, C202–C204) is applied to the PLL IC (IC2, pin 8). The applied signal is divided at the prescaler and programmable counter according to the "SSO" signal from the CPU (IC22, pin 99). The divided signal is phase-compared with the reference frequency signal from the reference frequency oscillator (X2), at the phase detector.

The phase difference is output from pin 5 as a pulse type signal after being passed through the internal charge pump. The output signal is converted into the DC voltage (lock voltage) by passing through the loop filter (R94–R96, C16, C17, C146). The lock voltage is applied to the varactors (D9 and D33 of RX VCO, D10 and D34 of TX VCO) and locked to keep the VCO frequency constant.

If the oscillated signal drifts, its phase changes from that of the reference frequency, causing a lock voltage change to compensate for the drift in the VCO oscillating frequency.

• PLL CIRCUITS

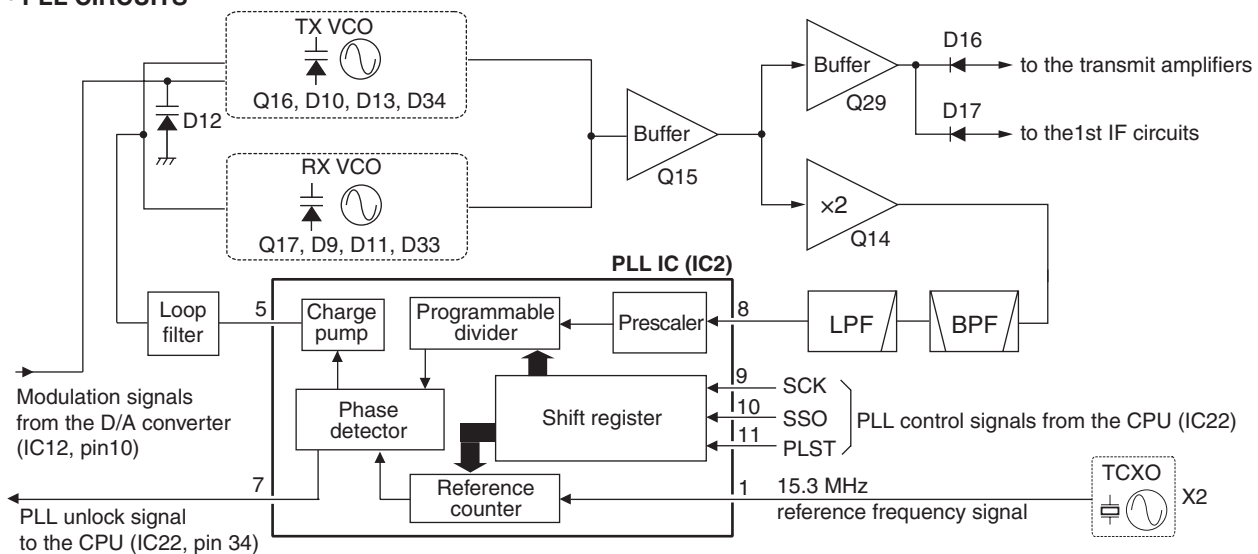

5-4 POWER SUPPLY CIRCUITS

Voltage from the attached battery pack is routed to whole of the circuit in the transceiver via a switch and regulators.

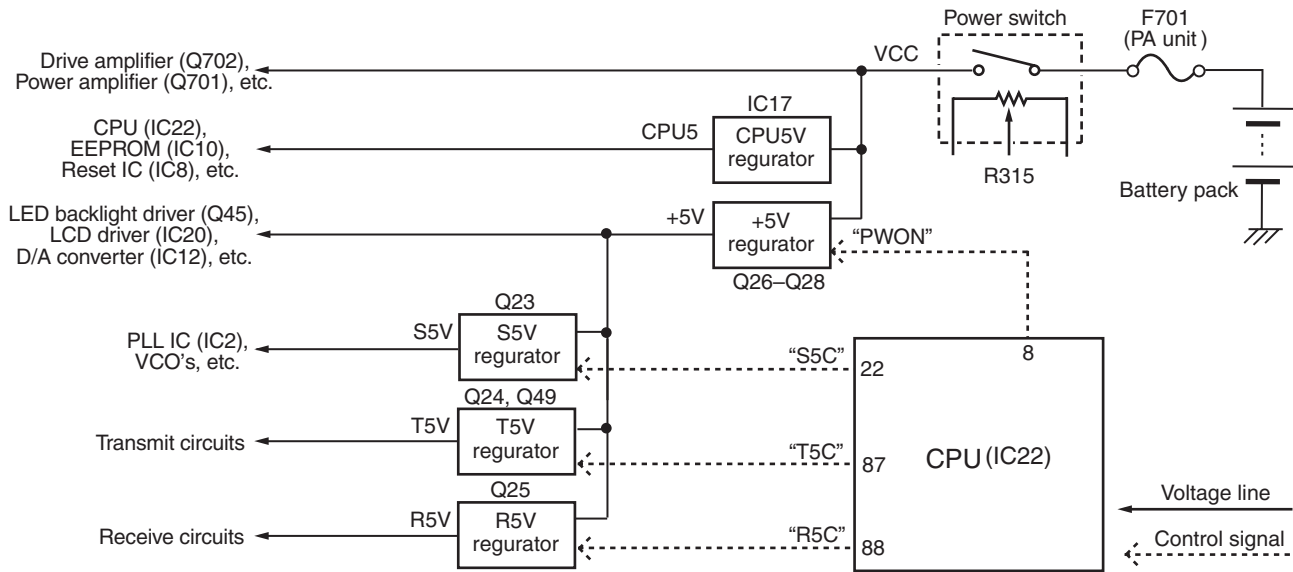

5-5 PORT ALLOCATIONS

5-5-1 CPU (IC22)

Pin No.	Port Name	Description
1-3	KR1-KR3	Input ports for dealer-programmable keys.
4-8	KS0-KS4	Output ports for dealer-programmable keys.
9	BUSY	Outputs "BUSY" signal to the DSP UNIT.
10	CCS	Outputs chip-select signal to the DSP UNIT.
11	SCK	Outputs serial clock signal to the PLL IC (IC2, pin 9) and D/A converter (IC12, pin 7/IC23, pin 7).
19-21	CENC0-CENC2	Output ports for CTCSS/DTCS signal.
22	S5C	Outputs S5V line control signal to the S5V regulator (Q23). "Low"=While power save mode.
26	T5C	Outputs T5V line control signal to the T5V line regulator (Q24, Q49). "Low"=While transmitting.
27	R5C	Outputs R5V line control signal to the R5V line regulator (Q25). "Low"=While receiving.
31	PLST	Outputs PLL strobe signal to the PLL IC (IC2, pin 11).
34	ULCK	Input port for PLL unlock detect signal from the PLL IC (IC2, pin 7). "Low"=While the PLL circuit is unlocked.
35	TMUT	Outputs transmit mute signal to the transmit mute switch (Q46). "High"=Transmitting is muted.
36	MONI	Input port for [SIDE1] key (S5). "Low"=While the key is pushed.
37	EMER	Input port for top switch (S1). "Low"=While the switch is pushed.
39	DSDA	Outputs serial data to the D/A converter (IC23, pin 6).
43	SENC	Outputs DTMF signals to the LPF (IC6, pin 3).
44	BEEP	Outputs beep sounds to the D/A converter (IC12, pin 21).
45	SDEC	Input port for DTMF signals.
46	CDEC	Input port for CTCSS/DTCS signals.
48	BATV	Input port for remaining battery power.
49	LVIN	Input port for VCO lock voltage.
50	RSSI	Input port for receive signal strength level signal from the FM IF IC (IC9, pin 12).
59	RES	Input port for CPU reset signal from the reset IC (IC8, pin 1). "Low"=When the CPU is reset.
69	CSFT	Outputs CPU clock shift signal to the clock shift switch (D6).
70	AFON	Outputs AF power amplifier (IC15) control signal to the AF power amplifier controller (Q41, Q42, D21, D23). "High"=The AF power amplifier is ON.
71	DAST	Outputs strobe signal to the D/A converter (IC12, pin 6).
72	DUSE	Outputs CTCSS/DTCS select signal to the tone filter switch (Q40). "High"=While DTCS is in use.
75	NOIS	Input port for noise signal from the FM IF IC (IC9, pin 13).
82	ESDA	Outputs serial data to the EEPROM (IC10, pin 5).
85	ESCL	Outputs clock signal to the EEPROM (IC10, pin 6).

Pin No.	Port Name	Description
89	DIGI	Outputs Analog/Digital select signal to the A/D switch (D2, D3). "High"=Digital mode is selected.
91	LSO	Outputs serial data to the LCD driver (IC20, pin 48).
92	LSCK	Outputs clock signal to the LCD driver (IC20, pin 47).
93	LCS	Outputs chip-enable signal to the LCD driver (IC20, pin 46).
94	LINH	Outputs display inhibit signal to the LCD driver (IC20, pin 45).
95	LIGT	Outputs LCD backlight control signal to the backlight LED's (DS1, DS2) driver (Q45). "Low"=While the backlight is ON.
96	RMUTE	Outputs AF mute signal to the analog switch (IC3, pins 12, 13). "Low"=While the squelch is close or transmitting.
97	MMUTE	Outputs MIC signals mute signal to the analog switch (IC3, pin 5) and MIC mute switch (Q31). "Low"=While receiving.
99	SSO	Outputs serial data to the PLL IC (IC2, 10) and D/A converter (IC12, pin 8).
100	KR0	Input ports for dealer-programmable keys.

5-5-2 D/A CONVERTER (IC12)

Pin No.	Port Name	Description
2	MCGO	Outputs level-adjusted MIC signals to the MIC mute switch (Q31).
10, 16	MOD	Outputs modulation signal to the modulation circuits (D2).
14	REF	Outputs reference frequency control voltage to the reference frequency oscillator buffer (IC7, pin 13).
15	BAL	Outputs modulation balance control signal to the reference frequency oscillator buffer (IC7, pin 12).
22	BEEPO	Outputs beep sounds to the AF volume buffer (IC6, pin 9).
23	SQLC	Outputs level-adjusted AF signals to the noise filter (IC9, pins 7, 8, R42, R44-R46, C69, C70, C413).

5-5-3 D/A CONVERTER (IC23)

Pin No.	Port Name	Description
1	T1	<ul style="list-style-type: none"> • While receiving Outputs BPF tuning voltage to the tunable BPF (D19, D25, L7, L8, C21-C23, C25, C27-C29). • While transmitting (as "APC" signal) Outputs transmit mute signal to the transmit mute switch (Q46).
2	T2	Outputs BPF tuning voltage to the tunable BPF (D14, D15, L9, L11, C19, C36, C39-C41, C44, C45).
3	TXLVA	Outputs oscillating frequency adjust voltage to the TX VCO (Q16, D10, D13).
4	RXLVA	Outputs oscillating frequency adjust voltage to the RX VCO (Q17, D9, D11).

SECTION 6 ADJUSTMENT PROCEDURES

6-1 PREPARATION

When adjusting IC-F3020 series, CS-F3020 CLONING SOFTWARE, CS-F3020 ADJ ADJUSTMENT SOFTWARE (Rev. 1.0 or later), OPC-478/U JIG CABLE (modified OPC-478/U CLONING CABLE; see the page 6-2) and the following test equipments are required.

EQUIPMENT	GRADE AND RANGE	EQUIPMENT	GRADE AND RANGE
DC power supply	Output voltage : 7.2 V DC Current capacity : More than 1.5 A	External speaker	Input impedance : 8 Ω Capacity : 1 W or more
FM deviation meter	Frequency range : DC–300 MHz Measuring range : 0 to ±10 kHz	Attenuator	Power attenuation : 20 or 30 dB Capacity : 7.5 W
Frequency counter	Frequency range : 0.1–300 MHz Frequency accuracy : ±1 ppm or better Sensitivity : 100 mV or better	Standard signal generator (SSG)	Frequency range : 0.1–300 MHz Output level : 0.1 μV to 32 mV (–127 to –17 dBm)
RF power meter	Measuring range : 0.1–7.5 W Frequency range : 100–300 MHz Impedance : 50 Ω SWR : Better than 1.2 : 1	Oscilloscope	Frequency rang : DC–20 MHz Measuring range : 0.01–20 V

■ SYSTEM REQUIREMENTS (for the ADJUSTMENT SOFTWARE)

- Microsoft® Windows® 98/98SE/Me/2000/XP
- RS-232C serial port (D-sub 9 pin) or USB port

■ ADJUSTMENT SOFTWARE INSTALLATION

- ① Quit all applications when Windows is running.
- ② Insert the CD into the appropriate CD drive.
- ③ Double-click the “Setup.exe” contained in the ‘CS-F3020 ADJ’ folder in the CD drive.
- ④ The “Welcome to the InstallShield Wizard for CS-F3020 ADJ” will appear. Click [Next>].
- ⑤ The “Choose Destination Location” will appear. Then click [Next>] to install the software to the destination folder. (e.g. C:\Program Files\lcom\CS-F3020 ADJ)
- ⑥ After the installation is completed, the “InstallShield Wizard Complete” will appear. Then click [Finish].
- ⑦ Eject the CD.
- ⑧ Program group ‘CS-F3020 ADJ’ appears in the ‘Programs’ folder of the start menu, and ‘CS-F3020 ADJ’ icon appears on the desk top screen.

■ BEFORE STARTING SOFTWARE ADJUSTMENT

Clone the adjustment frequencies and settings into the transceiver, and set the configuration using the CS-F3020 CLONING SOFTWARE before starting the software adjustment. Otherwise, the software adjustment can not be started.

CAUTION!: **BACK UP** the originally programmed memory data in the transceiver before programming the adjustment frequencies. When program the adjustment frequencies into the transceiver, the transceiver’s memory data will be overwritten and lose original memory data at the same time.

Microsoft and Windows are registered trademarks of Microsoft Corporation in the U.S.A. and other countries.

■ STARTING SOFTWARE ADJUSTMENT

- ① Connect the transceiver and PC with OPC-478/U JIG CABLE.
- ② Turn the transceiver power ON.
- ③ Boot up Windows, and click the program group ‘CS-F3020 ADJ’ in the ‘Programs’ folder of the [Start] menu, then CS-F3020 ADJ’s window appears.
- ④ Click ‘Connect’ on the CS-F3020 ADJ’s window, then the window shows transceiver’s condition and adjustment items as below.
- ⑤ Set or modify adjustment data as specified.

• ADJUSTMENT FREQUENCY LIST

CH	FREQUENCY	ADJUSTMENT ITEM
1	174.000 MHz	TX power : Low1 Mode : Narrow
2	136.000 MHz	TX power : Low1 Mode : Wide
3	155.000 MHz	TX power : High Mode : Wide
4	155.000 MHz	TX power : Low2 Mode : Wide
5	155.000 MHz	TX power : Low1 Mode : Narrow
6	155.000 MHz	TX power : Low1 Mode : Narrow DTCS : 007
7*	155.000 MHz	TX power : Low1 Mode : Middle
8	155.000 MHz	TX power : Low1 Mode : Wide CTCSS : 151.4 Hz
9	155.000 MHz	TX power : Low1 Mode : Wide

*; [EUR] only

• CONNECTION

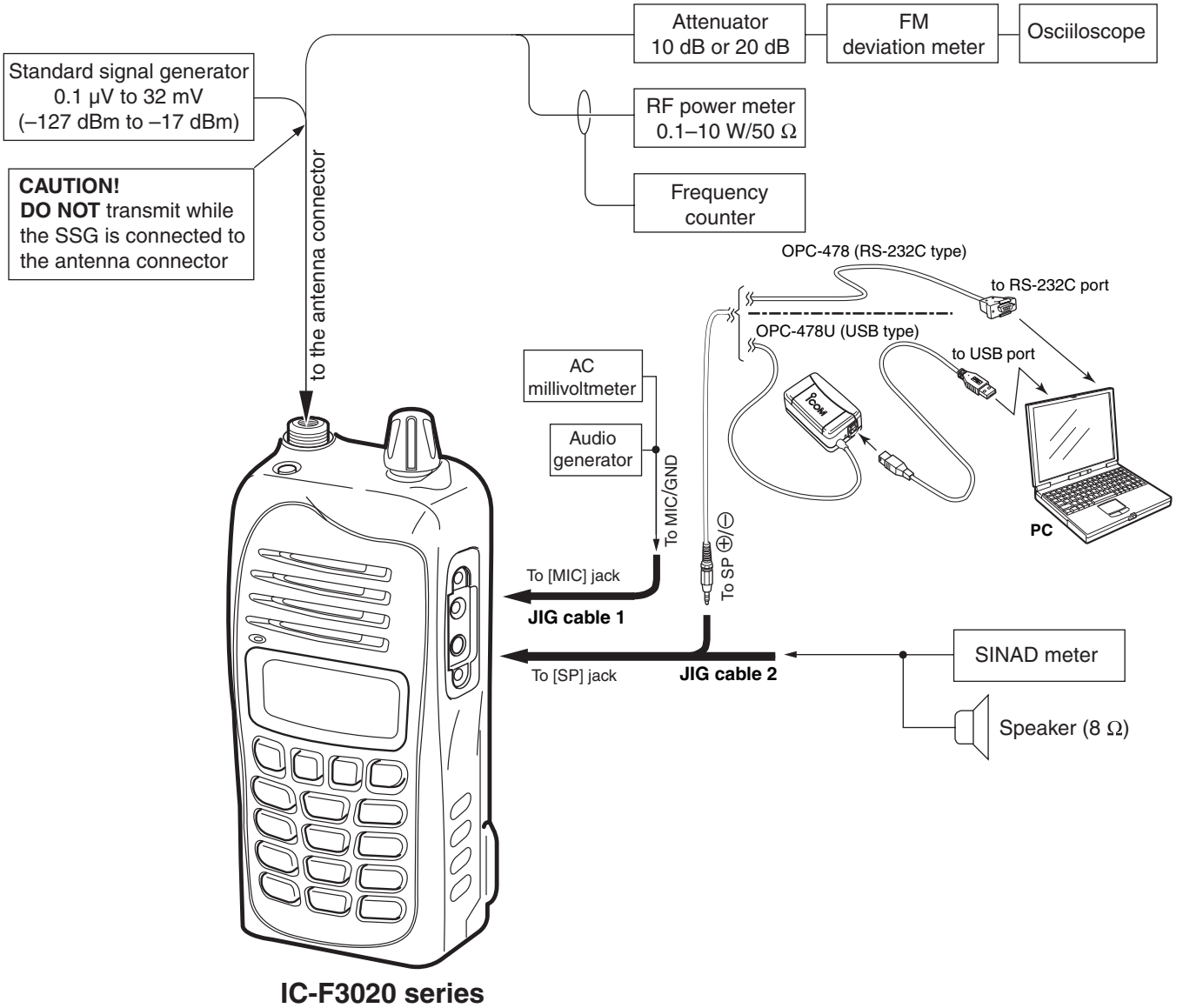

• JIG CABLES

[JIG cable 1]

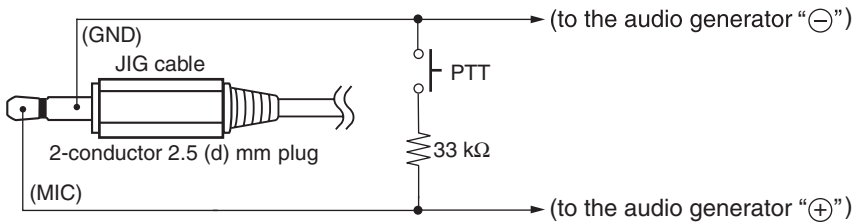

[JIG cable 2]

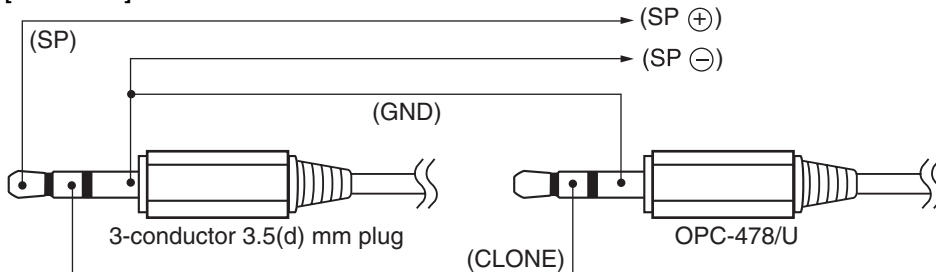

• PC SCREEN EXSAMPLE

NOTE: The above values for settings are example only.
Each transceiver has its own specific values for each setting.

- | | |
|-------------------------------|---------------------------------------|
| ① Transmit output power (Hi) | ⑨ Reference frequency |
| ② Transmit output power (L2) | ⑩ Receive sensitivity (Automatically) |
| ③ Transmit output power (L1) | ⑪ Receive sensitivity (Manually) |
| ④ Modulation balance | ⑫ PLL lock voltage |
| ⑤ FM deviation (Narrow) | ⑬ PLL lock voltage preset |
| ⑥ FM deviation (Middle*/Wide) | ⑭ S-meter |
| ⑦ CTCSS/DTCS deviation | ⑮ PLL lock voltage (verify) |
| ⑧ Squelch | ⑯ Reload data |

*; [EUR] only

6-2 FREQUENCY ADJUSTMENT

Select an adjustment item using [↑]/[↓] keys, then set to the specified value using [←-]/[→] keys on the connected PC's keyboard.

ADJUSTMENT	ADJUSTMENT CONDITION	MEASUREMENT		VALUE
		UNIT	OPERATION	
PLL LOCK VOLTAGE [RX LVA]	1 • Channel : CH 1 • Receiving	PC screen	Click [Reload (F5)] button, then check the "LVIN" item on the CS-F3020 ADJ's screen as below.	3.5 V
[TX LVA]	2 • Channel : CH 1 • Transmitting			
<p>CONVENIENT: The "PLL LOCK VOLTAGE" can be adjusted automatically. 1: Set the Lock voltage preset ([RX LVA] and [TX LVA]) to "179 (3.15 V)." 2: Push the [ENTER] key on the connected PC's keyboard.</p>				
	3 • Channel : CH 2 • Receiving	PC screen	Click [Reload (F5)] button, then check the "LVIN" item on the CS-F3020 ADJ's screen.	0.9–1.5 V (Verify)
	4 • Channel : CH 2 • Transmitting			1.0–1.6 V (Verify)
REFERENCE FREQUENCY [REF]	1 • Channel : CH 1 • Connect an RF power meter to the antenna connector. • Transmitting	Top panel	Loosely couple a frequency counter to the antenna connector.	174.000000 MHz

6-3 TRANSMIT ADJUSTMENT

Select an adjustment item using [↑]/[↓] keys, then set to the specified value using [←]/[→] keys on the connected PC's keyboard.

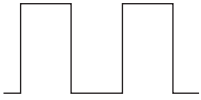
ADJUSTMENT		ADJUSTMENT CONDITION	MEASUREMENT		VALUE
			UNIT	OPERATION	
OUTPUT POWER [Power (Hi)]	1	• Channel : CH 3 • Transmitting	Top panel	Connect an RF power meter to the antenna connector.	5.0 W
	[Power (L2)]	2 • Channel : CH 4 • Transmitting			2.0 W
	[Power (L1)]	3 • Channel : CH 5 • Transmitting			1.0 W
MODULATION BALANCE [BAL]	1	• Channel : CH 6 • No audio applied to the JIG cable. • Set an FM deviation meter same as; HPF : OFF LPF : 20 kHz De-emphasis : OFF Detector : (P-P)/2 • Transmitting	Top panel	Connect the FM deviation meter to the antenna connector through an attenuator.	Set to square wave form 
FM DEVIATION (NARROW) [MOD N]	1	• Channel : CH 5 • Connect an audio generator to the JIG cable and set as; Frequency : 1.0 kHz Level : 150 mV rms • Set the FM deviation meter to same condition as "MODULATION BALANCE." • Transmitting	Top panel	Connect the FM deviation meter to the antenna connector through an attenuator.	±2.05 to ±2.15 kHz
	(WIDE) [MOD ratio]	2 • Channel : CH 9 • Transmitting			±4.05 to ±4.15 kHz
	(MIDDLE)* [MOD ratio]	3 • Channel : CH 7 • Transmitting			±3.15 to ±3.25 kHz
CTCSS/DTCS DEVIATION [CTCS/DTCS]	1	• Channel : CH 8 • No audio applied to the JIG cable. • Set the FM deviation meter to same condition as "MODULATION BALANCE." • Transmitting	Top panel	Connect an FM deviation meter to the antenna connector through an attenuator.	±0.68 to ±0.72 kHz

*; [EUR] only.

6-4 RECEIVE ADJUSTMENT

Select an adjustment item using [↑] / [↓] keys, then set to the specified value using [←] / [→] keys on the connected PC's keyboard.

ADJUSTMENT	ADJUSTMENT CONDITION	MEASUREMENT		VALUE	
		UNIT	LOCATION		
RECEIVE SENSITIVITY [BPF (T1)] [BPF (T2)]	NOTE: "RECEIVE SENSITIVITY" must be adjusted before "S-METER." Otherwise, "S-METER" will not be adjusted properly.				
	1	<ul style="list-style-type: none"> • Channel : CH 2 • Connect the SSG to the antenna connector and set as; <ul style="list-style-type: none"> Frequency : 136.000 MHz Level : +20 dBμ[†] (-87 dBm) Modulation : 1 kHz Deviation : ±3.5 kHz • Receiving 	[MIC/SP] jack	Connect the SINAD meter with an 8 Ω load to the JIG cable.	Minimum distortion level
CONVENIENT: The "RECEIVE SENSITIVITY" can be adjusted automatically. 1: Put the cursor on "BPF ALL" and push [ENTER] key. 2: The connected PC tunes BPF's to peak levels automatically.					
S-METER [RSSI]	1	<ul style="list-style-type: none"> • Channel : CH 2 • Connect the SSG to the antenna connector and set as; <ul style="list-style-type: none"> Frequency : 136.000 MHz Level : +23 dBμ[†] (-84 dBm) Modulation : 1 kHz Deviation : ±3.5 kHz • Receiving 	Push the [ENTER] key on the connected PC's keyboard to set "S3" level.		
	2	<ul style="list-style-type: none"> • Set the SSG as; <ul style="list-style-type: none"> Level : -7 dBμ[†] (-114 dBm) • Receiving 	Push the [ENTER] key on the connected PC's keyboard to set "S1" level.		
SQUELCH [SQL]	1	<ul style="list-style-type: none"> • Channel : CH 9 • Close the squelch by adjusting the value of [SQL] item on the CS-F3020 ADJ's screen. • Connect the SSG to the antenna connector and set as; <ul style="list-style-type: none"> Frequency : 155.000 MHz Level : -15 dBμ[†] (-122 dBm) Modulation : 1 kHz Deviation : ±3.5 kHz • Receiving 	External speaker	Connect an 8 Ω speaker to the JIG cable.	Set the [SQL] to the value that the audio signals just appears.

[†]The output level of the standard signal generator (SSG) is indicated as the SSG's open circuit.

SECTION 7 PARTS LIST

[MAIN UNIT]

REF NO.	ORDER NO.	DESCRIPTION	M.	H/V LOCATION
IC2	1140005991	S.IC MB15A02PFV1-G-BND-ERE1	T	81.2/34.5
IC3	11300011770	S.IC CD4066BPWR	B	40.4/22
IC5	1110005320	S.IC NJM13403V-TE1	B	40.4/12.8
IC6	1110006350	S.IC LM2902PWR	B	55.4/28.7
IC7	1110005340	S.IC NJM12902V-TE1	B	40.4/40.8
IC8	1110006260	S.IC BD5242G-TR	B	21.3/42
IC9	1110003201	S.IC TA31136FNG (EL)	T	81.6/17
IC10	1140008650	S.IC HN58X2464TI	B	4.4/37.1
IC12	1190001350	S.IC M62364FP 600D	B	40.4/30.6
IC15	1110001811	S.IC TA7368FG (5 ER)	T	98.9/18.3
IC17	1110005350	S.IC NJM2870F05-TE1	B	95.2/17
IC20	1130009090	S.IC LC75834W-TLM-E	T	57.3/20.3
IC22	1140011511	S.IC HD64F2238BTF13V	B	16.4/24.4
IC23	1190001340	S.IC M62334FP 600C	T	99.9/42.5
Q5	1580000731	S.FET 3SK293 (TE85L F)	B	92.4/38.2
Q6	1580000800	S.FET 3SK324UG-TL-E	B	88.6/23.4
Q7	1530003311	S.TR 2SC5107-O (TE85R F)	T	88.2/12.5
Q14	1530003980	S.TR 2SC5700WB-TR-E	B	79.9/31.3
Q15	1530003260	S.TR 2SC5006-T1	B	76.2/30
Q16	1530003260	S.TR 2SC5006-T1	B	75.5/25.7
Q17	1530003260	S.TR 2SC5006-T1	B	74.1/32.1
Q18	1590001400	S.TR XP1214 (TX)	T	74.3/28.3
Q19	1590003290	S.TR UNR9213J-(TX)	T	71.8/28.5
Q20	1530002851	S.TR 2SC4116-BL (TE85R F)	B	98.6/25.2
Q21	1560000541	S.FET 2SK880-Y (T5RICOM F)	T	76.8/25.4
Q22	1530003260	S.TR 2SC5006-T1	T	80.7/24.1
Q23	1510001110	S.TR 2SA1577T106R	B	51/6.3
Q24	1510001110	S.TR 2SA1577T106R	B	50.4/19.3
Q25	1510001110	S.TR 2SA1577T106R	B	85.7/12.3
Q26	1520000460	S.TR 2SB1132 T100 R	B	101.6/17.9
Q27	1590001190	S.TR XP6501-(TX) .AB	B	101.7/22.7
Q28	1590003290	S.TR UNR9213J-(TX)	B	99.4/20.6
Q29	1530003260	S.TR 2SC5006-T1	B	78.3/23.9
Q31	1560001360	S.FET 2SK3019 TL	B	41.9/6.8
Q32	1560001360	S.FET 2SK3019 TL	B	37.7/6.8
Q34	1560001360	S.FET 2SK3019 TL	B	46.6/12.8
Q39	1590001650	S.TR XP4601 (TX)	B	55.2/10.4
Q40	1590003290	S.TR UNR9213J-(TX)	B	40.6/37
Q41	1590001190	S.TR XP6501-(TX) .AB	T	96.4/24.6
Q42	1520000460	S.TR 2SB1132 T100 R	T	100.4/24.4
Q43	1590003380	S.TR UNR9111J-(TX)	T	78.4/7.2
Q44	1590003270	S.TR UNR9210J-(TX)	B	28.3/20
Q45	1590003230	S.TR UNR9113J-(TX)	T	53.8/4.8
Q46	1590003290	S.TR UNR9213J-(TX)	T	98.8/32.9
Q47	1590003290	S.TR UNR9213J-(TX)	B	86.4/14.6
Q49	1590003290	S.TR UNR9213J-(TX)	B	52.8/19.1
D4	1790001250	S.DIO MA2S111-(TX)	T	84/28.9
D6	1790001260	S.DIO MA2S077-(TX)	B	27.7/29.2
D8	1790001250	S.DIO MA2S111-(TX)	B	98.6/23.3
D9	1750000771	S.VCP HVC376BTRF-E	B	69.6/30.9
D10	1750000771	S.VCP HVC376BTRF-E	B	69.6/26.2
D11	1750000721	S.VCP HVC375BTRF-E	B	74.9/34
D12	1720000471	S.VCP 1SV239 (TPH3 F)	B	76.1/22.8
D13	1750000721	S.VCP HVC375BTRF-E	B	72/28.4
D16	1750000581	S.DIO 1SV307 (TPH3 F)	B	88.6/14.3
D17	1790001260	S.DIO MA2S077-(TX)	B	87.8/17.5
D19	1750000721	S.VCP HVC375BTRF-E	B	97.6/37.3
D20	1790001240	S.DIO MA2S728-(TX)	B	99/32.8
D21	1750000520	S.DIO DAN222TL	B	31.9/21.3
D23	1790001250	S.DIO MA2S111-(TX)	B	31.8/23
D24	1750000721	S.VCP HVC375BTRF-E	B	100.4/38.2
D28	1790001670	S.DIO RB706F-40T106	B	28/17.7
D31	1790001260	S.DIO MA2S077-(TX)	B	77.5/34.5
D32	1790001260	S.DIO MA2S077-(TX)	T	86.1/37
D33	1750000771	S.VCP HVC376BTRF-E	B	68.3/30.9
D34	1750000771	S.VCP HVC376BTRF-E	B	68.3/26.2
F11	2030000150	S.MLH FL-335 (46.350 MHz)	T	89.9/19.9
F12	2020001530	CER CFWLB450KFFA-B0		
X1	6070000190	S.DCR CDBC8450KAY24-R0	B	80/16.9
X2	6050011940	S.XTL CR-783 (15.3 MHz)		
X6	6050011830	S.XTL CR-774 (12.288 MHz)	B	31.2/31
L7	6200009930	S.COL C2012C-68NG-A	B	101.5/34.6
L8	6200009930	S.COL C2012C-68NG-A	B	95.8/38.6
L9	6200010090	S.COL ELJND R82JF	B	90/38.6
L12	6200008090	S.COL LQW2BHN68NJ03L	B	86.3/22.3

[MAIN UNIT]

REF NO.	ORDER NO.	DESCRIPTION	M.	H/V LOCATION
L13	6200007850	S.COL ELJNC R82K-F	T	88.7/26.1
L21	6200011031	S.COL ELJRF R10JFB	B	80.2/23
L22	6200011031	S.COL ELJRF R10JFB	B	77.8/28.2
L24	6200003640	S.COL MLF1608E 100K-T	B	70.9/26.2
L25	6200007770	S.COL LQW2BHN81J03L	B	71.2/22.9
L27	6200003550	S.COL MLF1608A 4R7K-T	T	69.8/27.2
L28	6200003550	S.COL MLF1608A 4R7K-T	T	68.8/29.8
L32	6200007911	S.COL ELJRF 18NJFB	T	88.2/35.8
L33	6200004480	S.COL MLF1608D R82K-T	T	80.6/22.4
L34	6200007901	S.COL ELJRF 22NJFB	T	87/33.3
L35	6200003540	S.COL MLF1608D R22K-T	T	84.6/25.4
L36	6200007901	S.COL ELJRF 22NJFB	T	86.1/33.3
L37	6200007720	S.COL LQW2BHN33NJ03L	B	68.6/33.8
L38	6200007760	S.COL LQW2BHN82NJ03L	B	71.2/34.2
L39	6200008090	S.COL LQW2BHN68NJ03L	B	68.6/23.3
L40	6200003640	S.COL MLF1608E 100K-T	B	70.9/30.9
L41	6200007911	S.COL ELJRF 18NJFB	B	80.5/29.5
L42	6200003550	S.COL MLF1608A 4R7K-T	T	72.2/34.5
L43	6200003550	S.COL MLF1608A 4R7K-T	T	72.4/25
L46	6200005681	S.COL ELJRE 15NGFA	B	89.3/20.3
L47	6200011670	S.COL LQW18AN82NG00D	B	90.1/36.4
L48	6200011650	S.COL LQW18AN68NG00D	B	89.5/29.7
L49	6200009101	S.COL ELJRE R18GFA	B	86/28.9
L50	6200003960	S.COL MLF1608A 1R0K-T	T	91/14.6
R6	70300005070	S.RES ERJ2GEJ 683 X (68 k)	T	99.5/34.8
R12	70300005530	S.RES ERJ2GEJ 100 X (10)	B	92.6/35.2
R13	70300005090	S.RES ERJ2GEJ 104 X (100 k)	B	99/39.2
R15	70300005310	S.RES ERJ2GEJ 124 X (120 k)	B	94.2/36.4
R16	70300008280	S.RES ERJ2GEJ 271 X (270)	B	93.3/40.4
R17	7030004970	S.RES ERJ2GEJ 470 X (47)	B	88.5/40.4
R18	7030007280	S.RES ERJ2GEJ 331 X (330)	B	85.5/38.8
R19	70300005090	S.RES ERJ2GEJ 104 X (100 k)	B	94.2/38.2
R24	70300005120	S.RES ERJ2GEJ 102 X (1 k)	B	85.3/16.7
R25	70300005070	S.RES ERJ2GEJ 683 X (68 k)	B	88.1/26.4
R26	70300005100	S.RES ERJ2GEJ 124 X (120 k)	B	88.5/25.4
R27	70300005100	S.RES ERJ2GEJ 154 X (150 k)	B	86.3/24.4
R28	70300005070	S.RES ERJ2GEJ 683 X (68 k)	B	84.5/24.4
R29	70300005590	S.RES ERJ2GEJ 680 X (68)	B	90.9/21.4
R31	70300004980	S.RES ERJ2GEJ 101 X (100)	B	86.3/25.4
R32	70300110040	S.RES ERJ2GEJ-JPW	T	90.5/25.3
R33	7030010040	S.RES ERJ2GEJ-JPW	T	89.2/14.6
R34	70300008300	S.RES ERJ2GEJ 184 X (180 k)	T	87.2/14.6
R35	7030007290	S.RES ERJ2GEJ 222 X (2.2 k)	T	85.2/14.6
R36	70300008410	S.RES ERJ2GEJ 392 X (3.9 k)	B	81.4/12.6
R38	70300005090	S.RES ERJ2GEJ 104 X (100 k)	T	81.7/12.2
R39	7030004970	S.RES ERJ2GEJ 470 X (47)	B	81.4/11.6
R40	70300005030	S.RES ERJ2GEJ 152 X (1.5 k)	T	82.2/21.3
R42	70300005120	S.RES ERJ2GEJ 102 X (1 k)	T	76.3/19.8
R43	70300005000	S.RES ERJ2GEJ 471 X (470)	T	78/14.6
R44	70300005230	S.RES ERJ2GEJ 334 X (330 k)	T	78/20.7
R45	70300005240	S.RES ERJ2GEJ 473 X (47 k)	T	76.3/20.7
R46	7030007300	S.RES ERJ2GEJ 332 X (3.3 k)	T	73.3/21.6
R48	70300005010	S.RES ERJ2GEJ 681 X (680)	T	86.2/12.9
R50	70300005010	S.RES ERJ2GEJ 103 X (10 k)	B	85.3/18.4
56	7030010040	S.RES ERJ2GEJ-JPW	T	72.3/15.2
R60	70300009140	S.RES ERJ2GEJ 272 X (2.7 k)	B	83.4/13.2
R67	70300004980	S.RES ERJ2GEJ 101 X (100)	B	88.7/10.9
R68	70300005050	S.RES ERJ2GEJ 103 X (10 k)	B	90.5/10.9
R69	70300005040	S.RES ERJ2GEJ 472 X (4.7 k)	B	86.3/16.7
R70	70300005530	S.RES ERJ2GEJ 100 X (10)	B	80.2/25.8
R71	70300005220	S.RES ERJ2GEJ 223 X (22 k)	B	79.2/26.7
R72	70300005120	S.RES ERJ2GEJ 102 X (1 k)	B	49/26.4
R75	70300005220	S.RES ERJ2GEJ 223 X (22 k)	B	78.7/29.5
R76	70300005530	S.RES ERJ2GEJ 100 X (10)	B	79.6/27.9
R77	70300004980	S.RES ERJ2GEJ 101 X (100)	B	80.5/27.9
R78	70300005090	S.RES ERJ2GEJ 104 X (100 k)	B	76/28.2
R79	70300008340	S.RES RR0510P-182-D (1.8 k)	B	72.3/31.8
R80	70300005060	S.RES ERJ2GEJ 333 X (33 k)	T	76.6/29.7
R82	70300009320	S.RES ERJ2GEJ 4R7 X (4.7)	B	73.5/25.1
R83	70300008340	S.RES RR0510P-182-D (1.8 k)	B	73.5/27.8
R84	7030011000	S.RES RR0510P-392-D (3.9 k)	B	73.7/24.2
R85	7030011000	S.RES RR0510P-392-D (3.9 k)	B	76.5/32.5
R86	70300005090	S.RES ERJ2GEJ 104 X (100 k)	T	74.5/23.6
R87	70300005000	S.RES ERJ2GEJ 471 X (470)	T	75.7/30.3
R88	70300008370	S.RES ERJ2GEJ 561 X (560)	T	74.5/26.5
R89	70300005050	S.RES ERJ2GEJ 103 X (10 k)	T	77.6/29.7
R91	70300005090	S.RES ERJ2GEJ 104 X (100 k)	T	72.7/20.7
R92	70300005230	S.RES ERJ2GEJ 334 X (330 k)	T	74.5/25.4
R94	70300004990	S.RES ERJ2GEJ 221 X (220)	T	77/32.8
R95	70300005120	S.RES ERJ2GEJ 102 X (1 k)	T	75.7/32
R96	70300007570	S.RES ERJ2GEJ 122 X (1.2 k)	T	77/31.9
R97	70300007340	S.RES ERJ2GEJ 153 X (15 k)	T	84.8/34.9
R98	7030007290	S.RES ERJ2GEJ 222 X (2.2 k)	B	99/22.2

[A]=USA-02 (F3021T) [B]=EUR-02 (F3022T) [C]=GEN-02 (F3023T)
 [D]=USA-02 (F3021S) [E]=EUR-02 (F3022S) [F]=GEN-02 (F3023S)

M.=Mounted side (T: Mounted on the Top side, B: Mounted on the Bottom side)
 S.=Surface mount

[MAIN UNIT]

REF NO.	ORDER NO.	DESCRIPTION	M.	H/V LOCATION
R99	7030007340	S.RES ERJ2GEJ 153 X (15 k)	B	79.6/34.7
R100	7030005040	S.RES ERJ2GEJ 472 X (4.7 k)	T	74.4/21.6
R101	7030004990	S.RES ERJ2GEJ 221 X (220)	T	77.6/28
R103	7030005230	S.RES ERJ2GEJ 334 X (330 k)	B	46.2/38.1
R104	7030005700	S.RES ERJ2GEJ 274 X (270 k)	B	47.2/38.1
R105	7030005230	S.RES ERJ2GEJ 334 X (330 k)	B	46.2/39.7
R106	7030005050	S.RES ERJ2GEJ 103 X (10 k)	B	47.2/39.7
R108	7030010040	S.RES ERJ2GEJ-JPW	B	65.2/37.6
R109	7030005050	S.RES ERJ2GEJ 103 X (10 k)	B	63.1/35.3
R110	7030005080	S.RES ERJ2GEJ 823 X (82 k)	T	69.3/20.7
R111	7030005170	S.RES ERJ2GEJ 474 X (470 k)	T	66.5/34.8
R115	7030005040	S.RES ERJ2GEJ 472 X (4.7 k)	T	83.4/25.9
R116	7030007060	S.RES ERJ2GEJ 684X (680 k)	T	80.7/25.6
R121	7030005060	S.RES ERJ2GEJ 333 X (33 k)	B	68.8/41.3
R122	7030005050	S.RES ERJ2GEJ 103 X (10 k)	T	98.3/39.1
R123	7030005050	S.RES ERJ2GEJ 103 X (10 k)	B	99.8/42.1
R124	7030005090	S.RES ERJ2GEJ 104 X (100 k)	T	73.8/24.5
R126	7030004980	S.RES ERJ2GEJ 101 X (100)	B	23.2/4.5
R127	7030009140	S.RES ERJ2GEJ 272 X (2.7 k)	B	33.7/10.9
R128	7030008400	S.RES ERJ2GEJ 182 X (1.8 k)	B	33.7/9.2
R129	7030005720	S.RES ERJ2GEJ 563 X (56 k)	B	35.7/9.2
R133	7030005090	S.RES ERJ2GEJ 104 X (100 k)	B	35.4/5.3
R134	7030005050	S.RES ERJ2GEJ 103 X (10 k)	B	43.9/8.5
R135	7030008410	S.RES ERJ2GEJ 392 X (3.9 k)	B	43.9/9.5
R136	7030005240	S.RES ERJ2GEJ 473 X (47 k)	B	40.7/9.5
R137	7030005080	S.RES ERJ2GEJ 823 X (82 k)	B	45/12.7
R138	7030005000	S.RES ERJ2GEJ 471 X (470)	B	45/14.3
R139	7030008310	S.RES ERJ2GEJ 564 X (560 k)	B	43.6/16.6
R140	7030005700	S.RES ERJ2GEJ 274 X (270 k)	B	41.9/17.5
R141	7030010040	S.RES ERJ2GEJ-JPW	B	37.4/18.6
R142	7030008410	S.RES ERJ2GEJ 392 X (3.9 k)	B	36.7/9.2
R143	7030005100	S.RES ERJ2GEJ 154 X (150 k)	B	33.7/16
R144	7030005700	S.RES ERJ2GEJ 274 X (270 k)	B	37.4/17.5
R145	7030005100	S.RES ERJ2GEJ 154 X (150 k)	B	34.7/17.7
R146	7030005060	S.RES ERJ2GEJ 333 X (33 k)	B	34.7/16
R147	7030005100	S.RES ERJ2GEJ 154 X (150 k)	B	35.7/17.7
R148	7030005000	S.RES ERJ2GEJ 471 X (470)	B	37.4/16.3
R149	7030005110	S.RES ERJ2GEJ 224 X (220 k)	B	33.7/17.7
R150	7030008310	S.RES ERJ2GEJ 564 X (560 k)	B	43.6/17.5
R151	7030005080	S.RES ERJ2GEJ 823 X (82 k)	B	35/38.5
R153	7030005310	S.RES ERJ2GEJ 124 X (120 k)	B	35.9/42.9
R154	7030005080	S.RES ERJ2GEJ 823 X (82 k)	B	35.9/41.3
R155	7030005720	S.RES ERJ2GEJ 563 X (56 k)	B	35.9/37.1
R156	7030005050	S.RES ERJ2GEJ 103 X (10 k)	B	48.1/16.4
R158	7030005160	S.RES ERJ2GEJ 105 X (1 M)	B	37.9/37.1
R159	7030005120	S.RES ERJ2GEJ 102 X (1 k)	B	35.9/39.7
R160	7030005050	S.RES ERJ2GEJ 103 X (10 k)	B	35/39.7
R161	7030005050	S.RES ERJ2GEJ 103 X (10 k)	B	48/19.7
R162	7030005040	S.RES ERJ2GEJ 472 X (4.7 k)	B	48/18.8
R163	7030005050	S.RES ERJ2GEJ 103 X (10 k)	B	87.6/12.1
R164	7030005050	S.RES ERJ2GEJ 103 X (10 k)	B	85.7/10.5
R165	7030005050	S.RES ERJ2GEJ 103 X (10 k)	B	102.6/14.7
R166	7030005040	S.RES ERJ2GEJ 472 X (4.7 k)	B	101.2/24.6
R167	7030005050	S.RES ERJ2GEJ 103 X (10 k)	B	48.2/6.3
R168	7030005050	S.RES ERJ2GEJ 103 X (10 k)	B	49.1/6.3
R169	7030004980	S.RES ERJ2GEJ 101 X (100)	B	101.2/25.6
R172	7030005220	S.RES ERJ2GEJ 223 X (22 k)	T	92.1/33.7
R181	7030005220	S.RES ERJ2GEJ 223 X (22 k)	B	57/6.3
R182	7030005220	S.RES ERJ2GEJ 223 X (22 k)	B	57/8
R183	7030005220	S.RES ERJ2GEJ 223 X (22 k)	B	55.2/8
R184	7030007340	S.RES ERJ2GEJ 153 X (15 k)	B	53.4/10
R185	7030007300	S.RES ERJ2GEJ 332 X (3.3 k)	B	52.5/10
R186	7030005090	S.RES ERJ2GEJ 104 X (100 k)	B	57/10
R187	7030005070	S.RES ERJ2GEJ 683 X (68 k)	B	55.2/12.8
R188	7030005050	S.RES ERJ2GEJ 103 X (10 k)	B	53.4/8
R190	7030007570	S.RES ERJ2GEJ 122 X (1.2 k)	B	54.3/12.8
R194	7030005090	S.RES ERJ2GEJ 104 X (100 k)	B	57.9/22.2
R195	7030005090	S.RES ERJ2GEJ 104 X (100 k)	B	60.2/23.5
R196	7030007350	S.RES ERJ2GEJ 393 X (39 k)	B	60.2/24.4
R197	7030005080	S.RES ERJ2GEJ 823 X (82 k)	B	60.2/26.7
R198	7030008300	S.RES ERJ2GEJ 184 X (180 k)	B	57/24.4
R199	7030006610	S.RES ERJ2GEJ 394 X (390 k)	B	58.6/24.4
R200	7030005030	S.RES ERJ2GEJ 152 X (1.5 k)	B	58.6/25.4
R201	7030005050	S.RES ERJ2GEJ 103 X (10 k)	T	96.6/39.1
R202	7030005000	S.RES ERJ2GEJ 471 X (470)	T	96.6/38.1
R209	7030005070	S.RES ERJ2GEJ 683 X (68 k)	B	47.2/41.3
R210	7030005240	S.RES ERJ2GEJ 473 X (47 k)	B	46.2/42.9
R211	7030005240	S.RES ERJ2GEJ 473 X (47 k)	B	46.2/41.3
R213	7030005040	S.RES ERJ2GEJ 472 X (4.7 k)	B	42.2/37
R214	7030005240	S.RES ERJ2GEJ 473 X (47 k)	B	44.2/37
R215	7030005070	S.RES ERJ2GEJ 683 X (68 k)	B	55/32
R216	7030005070	S.RES ERJ2GEJ 683 X (68 k)	B	56.7/32
R217	7030005070	S.RES ERJ2GEJ 683 X (68 k)	B	60.2/30
R218	7030005070	S.RES ERJ2GEJ 683 X (68 k)	B	60.2/32
R219	7030005240	S.RES ERJ2GEJ 473 X (47 k)	B	58.4/33
R220	7030005220	S.RES ERJ2GEJ 223 X (22 k)	B	60.2/34
R221	7030005220	S.RES ERJ2GEJ 223 X (22 k)	B	48.2/39.7
R222	7030008300	S.RES ERJ2GEJ 184 X (180 k)	B	7/19.3
R223	7030005720	S.RES ERJ2GEJ 563 X (56 k)	B	7/20.3
R224	7030005220	S.RES ERJ2GEJ 223 X (22 k)	B	7/21.3
R225	7030007260	S.RES ERJ2GEJ 330 X (33 k)	T	94.4/20.7

[A]=USA-02 (F3021T) [B]=EUR-02 (F3022T) [C]=GEN-02 (F3023T)
 [D]=USA-02 (F3021S) [E]=EUR-02 (F3022S) [F]=GEN-02 (F3023S)

[MAIN UNIT]

REF NO.	ORDER NO.	DESCRIPTION	M.	H/V LOCATION
R226	7030005300	S.RES ERJ2GEJ 150 X (15)	T	94.5/22.5
R227	7030009140	S.RES ERJ2GEJ 272 X (2.7 k)	T	97.4/16.6
R228	7030007300	S.RES ERJ2GEJ 332 X (3.3 k)	T	95.5/22.5
R229	7030005120	S.RES ERJ2GEJ 102 X (1 k)	T	95.4/26.7
R230	7030005230	S.RES ERJ2GEJ 334 X (330 k)	B	34.1/22.6
R231	7030005100	S.RES ERJ2GEJ 154 X (150 k)	B	34.1/21.6
R233	7030004980	S.RES ERJ2GEJ 101 X (100)	B	98.7/12.1
R234	7030005530	S.RES ERJ2GEJ 100 X (10)	T	103.3/16.8
R235	7030005000	S.RES ERJ2GEJ 471 X (470)	T	80.5/8
R236	7030005090	S.RES ERJ2GEJ 104 X (100 k)	T	77.2/8.5
R237	7030005030	S.RES ERJ2GEJ 152 X (1.5 k)	T	78.8/5.5
R238	7030005000	S.RES ERJ2GEJ 471 X (470)	B	85.7/5.4
R239	7030007340	S.RES ERJ2GEJ 153 X (15 k)	B	26.3/19.5
R240	7030005060	S.RES ERJ2GEJ 333 X (33 k)	B	50.6/24.4
R241	7030005110	S.RES ERJ2GEJ 224 X (220 k)	B	50.6/28.5
R242	7030005160	S.RES ERJ2GEJ 105 X (1 M)	B	50.6/27.4
R243	7030007340	S.RES ERJ2GEJ 153 X (15 k)	B	52.2/24.4
R244	7030005240	S.RES ERJ2GEJ 473 X (47 k)	B	53.8/24.4
R245	7030005090	S.RES ERJ2GEJ 104 X (100 k)	B	50.6/25.4
R246	7030005090	S.RES ERJ2GEJ 104 X (100 k)	B	45.8/32.1
R247	7030005000	S.RES ERJ2GEJ 471 X (470)	B	45.8/35.1
R248	7030005050	S.RES ERJ2GEJ 103 X (10 k)	B	43.9/5.3
R249	7030005120	S.RES ERJ2GEJ 102 X (1 k)	B	45.2/20.6
R254	7030005090	S.RES ERJ2GEJ 104 X (100 k)	B	58.4/34
R255	7030008290	S.TMR ERJ2GEJ 183 X (18 k)	B	56.7/33
R256	7510001730	S.TMR ERTJOEP 473J	B	18.7/39.4
R257	7030005090	S.RES ERJ2GEJ 104 X (100 k)	B	18.7/37.4
R258	7030005530	S.RES ERJ2GEJ 100 X (10)	B	26.3/31.0
R259	7030005160	S.RES ERJ2GEJ 105 X (1 M)	B	26.3/32.4
R260	7030008010	S.RES ERJ2GEJ 123 X (12 k)	B	27.7/31.3
R261	7030008010	S.RES ERJ2GEJ 123 X (12 k)	B	26.3/29.4
R262	7030008010	S.RES ERJ2GEJ 123 X (12 k)	B	26.3/28.4
R263	7030005090	S.RES ERJ2GEJ 104 X (100 k)	B	16.8/41.4
R264	7030005820	S.RES RR0510P-103-D (10 k)	B	10.7/4.7
R265	7030005820	S.RES RR0510P-103-D (10 k)	B	8.8/4.7
R272	7030004980	S.RES ERJ2GEJ 101 X (100)	T	55.4/4.8
R273	7030005160	S.RES ERJ2GEJ 105 X (1 M)	B	8/10.5
R274	7030005160	S.RES ERJ2GEJ 105 X (1 M)	B	8/11.5
R275	7030005160	S.RES ERJ2GEJ 105 X (1 M)	B	7.4/14
R276	7030005160	S.RES ERJ2GEJ 105 X (1 M)	B	7.4/16.2
R277	7030005160	S.RES ERJ2GEJ 105 X (1 M)	B	10.6/37
R278	7030005160	S.RES ERJ2GEJ 105 X (1 M)	B	14.5/40.2
R279	7030005090	S.RES ERJ2GEJ 104 X (100 k)	B	12.8/4.7
R280	7030005090	S.RES ERJ2GEJ 104 X (100 k)	B	14.2/4.7
R281	7030009270	S.RES ERJ2GEJ 821 X (820)	B	20.5/4
R288	7030005040	S.RES ERJ2GEJ 472 X (4.7 k)	B	6.6/18
R291	7030005120	S.RES ERJ2GEJ 102 X (1 k)	B	9.9/15.4
R292	7030005090	S.RES ERJ2GEJ 104 X (100 k)	B	5.5/31.5
R293	7030005050	S.RES ERJ2GEJ 103 X (10 k)	B	5.5/32.5
R295	7030005240	S.RES ERJ2GEJ 473 X (47 k)	T	62.1/14.1
R300	7030005090	S.RES ERJ2GEJ 104 X (100 k)	T	61.7/16.4
R302	7030005090	S.RES ERJ2GEJ 104 X (100 k)	B	99/38.3
R303	7030005050	S.RES ERJ2GEJ 103 X (10 k)	B	99/37.4
R307	7030005580	S.RES ERJ2GEJ 560 X (56)	T	86.1/31.7
R308	7030007340	S.RES ERJ2GEJ 153 X (15 k)	T	69.3/21.6
R309	7030005050	S.RES ERJ2GEJ 103 X (10 k)	B	48.2/41.3
R315	7210003061	VAR TP76N00N-15F-A103-2251A		
R321	7030005090	S.RES ERJ2GEJ 104 X (100 k)	B	14.5/41.4
R345	7030005120	S.RES ERJ2GEJ 102 X (1 k)	T	82/39.3
R346	7030005120	S.RES ERJ2GEJ 102 X (1 k)	T	82.9/39.3
R347	7030005120	S.RES ERJ2GEJ 102 X (1 k)	T	83.8/39.3
R348	7030005120	S.RES ERJ2GEJ 102 X (1 k)	T	84/30.1
R349	7030005120	S.RES ERJ2GEJ 102 X (1 k)	B	26.3/23
R350	7030005120	S.RES ERJ2GEJ 102 X (1 k)	B	8.5/29.1
R351	7030005120	S.RES ERJ2GEJ 102 X (1 k)	B	26.3/21.6
R352	7030005120	S.RES ERJ2GEJ 102 X (1 k)	B	7.6/27.6
R353	7410001130	S.ARY EXB28V102X	B	12.1/15.7
R354	7030005090	S.RES ERJ2GEJ 104 X (100 k)	B	12.3/34.4
R361	7030005000	S.RES ERJ2GEJ 471 X (470)	B	90.9/27.4
R363	7030005100	S.RES ERJ2GEJ 154 X (150 k)	T	84/27.7
R367	7030004980	S.RES ERJ2GEJ 101 X (100)	B	23.7/9.9
R368	7030005090	S.RES ERJ2GEJ 104 X (100 k)	B	42.2/5.3
R369	7030005090	S.RES ERJ2GEJ 104 X (100 k)	B	35.4/4.4
R370	7030010040	S.RES ERJ2GEJ-JPW [G], [H], [I] only	B	10.2/17
R371	7030005210	S.RES ERJ2GEJ 822 X (8.2 k)	B	27.3/11.4
R372	7030005040	S.RES ERJ2GEJ 472 X (4.7 k)	B	27.3/14.4
R375	7030005090	S.RES ERJ2GEJ 104 X (100 k)	B	35.7/12.6
R376	7030010040	S.RES ERJ2GEJ-JPW	B	34.7/19.3
R377	7030005120	S.RES ERJ2GEJ 102 X (1 k)	B	46.7/25.4
R379	7030004980	S.RES ERJ2GEJ 101 X (100)	T	69.4/7.4
R380	7030005050	S.RES ERJ2GEJ 103 X (10 k)	T	71/21.6
R381	7030005050	S.RES ERJ2GEJ 103 X (10 k)	B	49/28.5
C16	4550006910	S.TAN TEESVP 1C 334M8R	T	73.3/32.3
C17	4550002980	S.TAN TEESVA 1C 225M8R	T	77.3/36.1
C19	4030017420	S.CFER ECJ0EC1H470J	B	88.1/37.5
C22	4030017550	S.CFER ECJ0EC1H1R5B	B	99/36.5
C24	4030017460	S.CFER ECJ0EB1E102K	B	102.5/41.6
C25	4030017580	S.CFER ECJ0EC1H060C	B	99/34.8
C26	4030017460	S.CFER ECJ0EB1E102K	B	50.6/26.4

M.=Mounted side (T: Mounted on the Top side, B: Mounted on the Bottom side)
 S.=Surface mount

[MAIN UNIT]

REF NO.	ORDER NO.	DESCRIPTION	M.	H/V LOCATION
C27	4030017430	S.CER ECJ0EC1H101J	B	100.4/40.4
C28	4030017360	S.CER ECJ0EC1H030B	B	97.4/39.5
C29	4030017580	S.CER ECJ0EC1H060C	B	95.8/36.5
C30	4030017460	S.CER ECJ0EB1E102K	T	90/34.5
C32	4030017460	S.CER ECJ0EB1E102K	B	92.4/40.4
C33	4030017420	S.CER ECJ0EC1H470J	B	91.5/40.4
C36	4030017460	S.CER ECJ0EB1E102K	B	87.6/40.4
C40	4030017670	S.CER ECJ0EC1H390J	B	88.1/34.2
C42	4030017460	S.CER ECJ0EB1E102K	B	92.6/33.2
C46	4030017420	S.CER ECJ0EC1H470J	B	84.5/22.4
C47	4030017460	S.CER ECJ0EB1E102K	B	84.5/23.4
C48	4030016790	S.CER ECJ0EB1C103K	B	90.9/23.4
C49	4030017600	S.CER ECJ0EC1H080C	B	88/21.4
C50	4030017460	S.CER ECJ0EB1E102K	B	90.9/22.4
C51	4030017460	S.CER ECJ0EB1E102K	T	90.5/26.9
C52	4030017620	S.CER ECJ0EC1H100C	B	90.9/26.4
C53	4030016790	S.CER ECJ0EB1C103K	B	90.9/24.4
C54	4030017460	S.CER ECJ0EB1E102K	B	90.9/25.4
C55	4030017570	S.CER ECJ0EC1H040B	T	91.4/25.3
C56	4030017400	S.CER ECJ0EC1H220J	T	86.1/18.3
C57	4030017460	S.CER ECJ0EB1E102K	B	84.5/25.4
C58	4030017460	S.CER ECJ0EB1E102K	T	88.2/14.6
C59	4030017460	S.CER ECJ0EB1E102K	T	85.2/16.3
C60	4030016790	S.CER ECJ0EB1C103K	T	86.2/14.6
C61	4030017430	S.CER ECJ0EC1H101J	T	85.2/12.9
C62	4030017510	S.CER ECJ0EC1H680J	T	79.6/12.6
C63	4030017420	S.CER ECJ0EC1H470J	T	83.5/12.2
C65	4030016930	S.CER ECJ0EB1A104K	B	15.6/34.4
C66	4030017460	S.CER ECJ0EB1E102K	T	78/13.6
C67	4030017460	S.CER ECJ0EB1E102K	B	79.3/12.7
C69	4030017700	S.CER ECJ0EC1H151J	T	78/21.6
C70	4030017700	S.CER ECJ0EC1H151J	T	78/19.8
C71	4030016930	S.CER ECJ0EB1A104K	T	80.6/21.3
C72	4030017420	S.CER ECJ0EC1H470J	B	97.3/34.8
C73	4030018110	S.CER ECJ0EB1H272K	T	82.6/12.2
C74	4030016930	S.CER ECJ0EB1A104K	T	80.8/12.2
C75	4550006250	S.TAN TEESVA 1A 106M8R	B	75.6/12.2
C76	4030016790	S.CER ECJ0EB1C103K	B	84.3/14.1
C79	4030016930	S.CER ECJ0EB1A104K	T	95.3/38.7
C80	4550007090	S.TAN TEESVA 1A 226M8R	T	96.6/35.1
C81	4030017420	S.CER ECJ0EC1H470J	T	98.3/38.1
C82	4030017420	S.CER ECJ0EC1H470J	B	102.7/32.1
C99	4030017460	S.CER ECJ0EB1E102K	B	89.7/12.1
C100	4030017620	S.CER ECJ0EC1H100C	B	86.3/18.4
C101	4030017460	S.CER ECJ0EB1E102K	B	79.6/32.9
C102	4030017590	S.CER ECJ0EC1H070C	B	78.7/27.9
C103	4030017380	S.CER ECJ0EC1H050B	B	77.8/29.8
C104	4030017460	S.CER ECJ0EB1E102K	B	76.9/28.2
C105	4030017460	S.CER ECJ0EB1E102K	B	79.6/29.5
C107	4030017460	S.CER ECJ0EB1E102K	B	80.2/23.9
C108	4030017460	S.CER ECJ0EB1E102K	B	91.3/12.1
C109	4030017460	S.CER ECJ0EB1E102K	B	80.2/24.8
C110	4030017420	S.CER ECJ0EC1H470J	T	80.4/28
C111	4030017420	S.CER ECJ0EC1H470J	T	72.9/30.1
C113	4030017540	S.CER ECJ0EC1HR75B	B	74.7/29.3
C114	4030017660	S.CER ECJ0EC1H330J	B	75.6/32.5
C115	4030017660	S.CER ECJ0EC1H330J	B	74.1/30.5
C116	4030016790	S.CER ECJ0EB1C103K	B	73.5/29.6
C117	4030017730	S.CER ECJ0EB1E471K	B	73.5/28.7
C118	4030017530	S.CER ECJ0EC1H0R5B	B	74.7/27.5
C119	4030017460	S.CER ECJ0EB1E102K	B	77.4/27
C120	4030017730	S.CER ECJ0EB1E471K	B	77.1/25.8
C121	4030017390	S.CER ECJ0EC1H180J	B	73.5/26
C122	4030017660	S.CER ECJ0EC1H330J	B	76.1/24.2
C123	4030017510	S.CER ECJ0EC1H680J	B	72/24.4
C126	4030017660	S.CER ECJ0EC1H330J	B	72.3/32.7
C129	4030017340	S.CER ECJ0EC1H010B	B	73.7/23.3
C133	4030017390	S.CER ECJ0EC1H180J	B	72.3/25.6
C134	4030017390	S.CER ECJ0EC1H180J	T	73.2/34.2
C135	4030017460	S.CER ECJ0EB1E102K	T	74.5/30.1
C137	4030016790	S.CER ECJ0EB1C103K	T	98.1/26.7
C138	4030017460	S.CER ECJ0EB1E102K	T	68.6/29.3
C139	4030016930	S.CER ECJ0EB1A104K	T	71.2/26.9
C141	4030017460	S.CER ECJ0EB1E102K	T	74.4/20.7
C143	4030017460	S.CER ECJ0EB1E102K	T	77.5/23.1
C144	4030017420	S.CER ECJ0EC1H470J	T	68.6/27.6
C145	4030017420	S.CER ECJ0EC1H470J	T	72.7/21.6
C146	4550006910	S.TAN TEESVP 1C 334M8R	T	71.5/32.3
C148	4550006250	S.TAN TEESVA 1A 106M8R	B	96.1/25.1
C149	4030017460	S.CER ECJ0EB1E102K	B	65.8/12.1
C150	4030018860	S.CER ECJ0EB0J105K	T	72.7/22.5
C151	4030017460	S.CER ECJ0EB1E102K	B	6.9/29.1
C152	4030017420	S.CER ECJ0EC1H470J	B	83.6/39.2
C153	4030017420	S.CER ECJ0EC1H470J	B	82.6/39.2
C154	4030017420	S.CER ECJ0EC1H470J	B	81.6/39.2
C155	4030017420	S.CER ECJ0EC1H470J	T	85.7/27.7
C156	4030017460	S.CER ECJ0EB1E102K	B	66.2/37.6
C157	4030017620	S.CER ECJ0EC1H100C	B	63.1/36.3
C158	4030016930	S.CER ECJ0EB1A104K	B	60.2/36.3
C159	4030017460	S.CER ECJ0EB1E102K	B	58.4/35.3
C160	4030017460	S.CER ECJ0EB1E102K	T	72.3/13.7

[MAIN UNIT]

REF NO.	ORDER NO.	DESCRIPTION	M.	H/V LOCATION
C161	4030017620	S.CER ECJ0EC1H100C	T	78.6/28
C162	4030017500	S.CER ECJ0EC1H560J	T	82.4/23.3
C163	4030017570	S.CER ECJ0EC1H040B	T	84.4/23.3
C164	4030017590	S.CER ECJ0EC1H070C	T	83.4/23.3
C165	4030016790	S.CER ECJ0EB1C103K	T	82.4/25.2
C166	4030017360	S.CER ECJ0EC1H030B	T	83.4/21.7
C167	4030016930	S.CER ECJ0EB1A104K	B	82.7/12
C168	4030017460	S.CER ECJ0EB1E102K	T	80.5/7.5
C169	4030017420	S.CER ECJ0EC1H470J	T	69.4/6.5
C170	4030018910	S.CER C1608 JB 0J 475K-T	B	33.9/40.5
C171	4030017460	S.CER ECJ0EB1E102K	B	69.7/41.3
C172	4030017460	S.CER ECJ0EB1E102K	B	67.9/41.3
C174	4030017710	S.CER ECJ0EC1H181J	B	35/42.9
C175	4030017420	S.CER ECJ0EC1H470J	B	70.6/41.3
C176	4030016930	S.CER ECJ0EB1A104K	T	99.6/38.7
C177	4030016930	S.CER ECJ0EB1A104K	B	96.9/42.1
C182	4030017460	S.CER ECJ0EB1E102K	B	84.3/18.4
C183	4030017620	S.CER ECJ0EC1H100C	B	87.8/19.3
C184	4030017460	S.CER ECJ0EB1E102K	B	94.2/40.4
C185	4030017460	S.CER ECJ0EB1E102K	T	90.5/40.3
C186	4030016930	S.CER ECJ0EB1A104K	T	93/33.7
C190	4030017590	S.CER ECJ0EC1H070C	B	72.3/30.9
C191	4030017650	S.CER ECJ0EC1H270J	B	70.4/32.7
C192	4030017440	S.CER ECJ0EC1H221J	B	70.4/24.4
C193	4030017580	S.CER ECJ0EC1H060C	B	70.3/28.3
C194	4030017360	S.CER ECJ0EC1H030B	B	69.3/28.3
C195	4030017360	S.CER ECJ0EC1H030B	B	68.3/28.3
C196	4030017360	S.CER ECJ0EC1H030B	B	78/33.4
C197	4030017590	S.CER ECJ0EC1H070C	B	79.6/33.8
C198	4030017460	S.CER ECJ0EB1E102K	T	84.8/33.1
C199	4030017360	S.CER ECJ0EC1H030B	T	88.2/34.9
C200	4030017590	S.CER ECJ0EC1H070C	T	86.1/34.9
C201	4030017600	S.CER ECJ0EC1H080C	T	87/34.9
C202	4030017600	S.CER ECJ0EC1H080C	T	88.2/34
C203	4030017640	S.CER ECJ0EC1H150J	T	88.2/33.1
C204	4030017600	S.CER ECJ0EC1H080C	T	87/31.7
C205	4030017570	S.CER ECJ0EC1H040B	T	84.8/34
C206	4030017460	S.CER ECJ0EB1E102K	T	84.8/35.8
C211	4030016970	S.CER ECJ0EB1C223K	B	58.6/23.5
C212	4030017740	S.CER ECJ0EB1E821K	B	60.2/25.4
C213	4030017740	S.CER ECJ0EB1E821K	B	60.2/27.7
C214	4030016930	S.CER ECJ0EB1A104K	B	55.4/25.4
C215	4030016950	S.CER ECJ0EB1A473K	B	57/25.4
C221	4030016940	S.CER ECJ0EB1A393K	B	56.1/6.3
C222	4030016790	S.CER ECJ0EB1C103K	B	54.3/8
C223	4030016930	S.CER ECJ0EB1A104K	B	56.1/8
C224	4030016970	S.CER ECJ0EB1C223K	B	52.5/8
C230	4030016790	S.CER ECJ0EB1C103K	B	48.7/5.1
C231	4030016790	S.CER ECJ0EB1C103K	B	48/20.6
C232	4030016790	S.CER ECJ0EB1C103K	B	85.5/9.2
C233	4550007090	S.TAN TEESVA 1A 226M8R	B	98/16.8
C234	4030016790	S.CER ECJ0EB1C103K	B	102.4/25.5
C235	4030016790	S.CER ECJ0EB1C103K	B	97.8/21.2
C236	4030018560	S.CER C2012 JB 1A 475K-T	B	96.3/20.8
C237	4030016790	S.CER ECJ0EB1C103K	B	94.7/14.7
C238	4550007070	S.TAN TEESVP 1A 475M8R	B	94.2/20.8
C239	4030016930	S.CER ECJ0EB1A104K	B	93/17.1
C240	4030017460	S.CER ECJ0EB1E102K	B	49.2/39.7
C241	4030017460	S.CER ECJ0EB1E102K	B	50.5/21.1
C242	4030017460	S.CER ECJ0EB1E102K	B	83.6/12
C246	4030017460	S.CER ECJ0EB1E102K	B	31.3/3.5
C247	4030018860	S.CER ECJ0EB0J105K	B	34.7/12.6
C248	4030016930	S.CER ECJ0EB1A104K	B	48.1/14.6
C249	4030016930	S.CER ECJ0EB1A104K	B	37.7/9.2
C250	4030016930	S.CER ECJ0EB1A104K	B	43.9/6.8
C251	4030016950	S.CER ECJ0EB1A473K	B	34.7/10.9
C252	4030016950	S.CER ECJ0EB1A473K	B	34.7/9.2
C253	4030016950	S.CER ECJ0EB1A473K	B	35.7/10.9
C254	4030016950	S.CER ECJ0EB1A473K	B	42.3/8.5
C255	4030016950	S.CER ECJ0EB1A473K	B	40.7/8.5
C256	4030016970	S.CER ECJ0EB1C223K	B	42.3/9.5
C257	4030016930	S.CER ECJ0EB1A104K	B	33.7/12.6
C258	4030017710	S.CER ECJ0EC1H181J	B	41.9/16.6
C259	4030016930	S.CER ECJ0EB1A104K	B	35/41.3
C260	4030016930	S.CER ECJ0EB1A104K	B	45/11.1
C262	4030016930	S.CER ECJ0EB1A104K	B	39.3/17.5
C263	4030016930	S.CER ECJ0EB1A104K	B	32.7/11.6
C265	4030017770	S.CER ECJ0EB1E332K	B	32.7/17.7
C266	4030017710	S.CER ECJ0EC1H181J	B	35.7/16
C267	4030016930	S.CER ECJ0EB1A104K	B	39.3/16.3
C268	4030016930	S.CER ECJ0EB1A104K	B	36.9/37.1
C269	4030016930	S.CER ECJ0EB1A104K	B	45.2/19.7
C271	4030017420	S.CER ECJ0EC1H470J	B	45.8/31.2
C272	4030016930	S.CER ECJ0EB1A104K	B	35.7/19.3
C297	4030017510	S.CER ECJ0EC1H680J	B	45.2/38.1
C298	4030017420	S.CER ECJ0EC1H470J	B	45.2/39.7
C301	4030016930	S.CER ECJ0EB1A104K	T	85.2/31.7
C302	4030017420	S.CER ECJ0EC1H470J	T	80/29.2
C303	4030018860	S.CER ECJ0EB0J105K	T	80/30.2
C312	4030017900	S.CER ECJ0EB1C123K	B	47.2/42.9
C314	4030017740	S.CER ECJ0EB1E821K	B	45.2/41.3

[A]=USA-02 (F3021T) [B]=EUR-02 (F3022T) [C]=GEN-02 (F3023T)
 [D]=USA-02 (F3021S) [E]=EUR-02 (F3022S) [F]=GEN-02 (F3023S)

M.=Mounted side (T: Mounted on the Top side, B: Mounted on the Bottom side)
 S.=Surface mount

[MAIN UNIT]

REF NO.	ORDER NO.	DESCRIPTION	M.	H/V LOCATION
C315	4030016930	S.CER ECJ0EB1A104K	B	43.2/37
C316	4030017420	S.CER ECJ0EC1H470J	B	53.3/32
C317	4030016790	S.CER ECJ0EB1C103K	B	55/33
C318	4030018140	S.CER ECJ0EB1H391K	B	60.2/31
C319	4030017760	S.CER ECJ0EB1H222K	B	58.4/32
C320	4030017460	S.CER ECJ0EB1E102K	B	60.2/33
C321	4030017460	S.CER ECJ0EB1E102K	T	85.8/4.6
C322	4030017420	S.CER ECJ0EC1H470J	T	94.4/19.1
C323	4030016950	S.CER ECJ0EB1A473K	T	94.5/14.3
C324	4550007110	S.TAN SY6-1A107M-RC	B	96/4.1
C325	4550006250	S.TAN TEESVA 1A 106M8R	T	93.9/24.1
C326	4550007080	S.TAN TEESVA 1C 106M8R	T	98.5/14.3
C327	4030016930	S.CER ECJ0EB1A104K	T	102.2/14.8
C328	4030017460	S.CER ECJ0EB1E102K	T	102.2/13.8
C329	4030017460	S.CER ECJ0EB1E102K	T	96.4/22.5
C330	4030016930	S.CER ECJ0EB1A104K	T	96.3/26.7
C331	4030017460	S.CER ECJ0EB1E102K	T	103.3/19.3
C332	4030017460	S.CER ECJ0EB1E102K	T	80.5/4.6
C333	4550006250	S.TAN TEESVA 1A 106M8R	T	83.1/3.4
C334	4030016930	S.CER ECJ0EB1A104K	T	76.3/8.5
C335	4030018860	S.CER ECJ0EB0J105K	B	55.4/24.4
C338	4030016930	S.CER ECJ0EB1A104K	B	45.8/34.1
C339	4030016790	S.CER ECJ0EB1C103K	B	45.8/30.2
C340	4030016930	S.CER ECJ0EB1A104K	B	10.2/17.9
C345	4030016930	S.CER ECJ0EB1A104K	B	18.7/38.4
C346	4030017600	S.CER ECJ0EC1H080C	B	27.7/32.9
C347	4030017640	S.CER ECJ0EC1H150J	B	26.3/33.4
C348	4030017400	S.CER ECJ0EC1H220J	B	26.3/30.4
C349	4030016930	S.CER ECJ0EB1A104K	B	25.1/29.4
C350	4030016930	S.CER ECJ0EB1A104K	B	27.7/27.1
C351	4030016930	S.CER ECJ0EB1A104K	B	26.6/27.1
C352	4030017030	S.CER ECJ0EB1A273K	B	23.5/41.4
C353	4030016930	S.CER ECJ0EB1A104K	B	9.7/4.7
C354	4030016790	S.CER ECJ0EB1C103K	B	5.5/30.5
C355	4030017460	S.CER ECJ0EB1E102K	B	52.8/5.1
C357	4030018910	S.CER C1608 JB 0J 475K-T	B	29.1/23
C359	4030016930	S.CER ECJ0EB1A104K	B	21.7/38.4
C360	4030017420	S.CER ECJ0EC1H470J	B	20.2/34.9
C361	4030016930	S.CER ECJ0EB1A104K	B	20.2/33.9
C366	4030017460	S.CER ECJ0EB1E102K	B	99.4/40.4
C367	4030017730	S.CER ECJ0EB1E471K	B	53.8/25.4
C368	4030016930	S.CER ECJ0EB1A104K	B	49/27.4
C369	4030017430	S.CER ECJ0EC1H101J	B	98.4/40.4
C370	4030016930	S.CER ECJ0EB1A104K	B	49/25.4
C371	4030016930	S.CER ECJ0EB1A104K	B	50.6/29.5
C372	4030018860	S.CER ECJ0EB0J105K	B	49/24.4
C373	4030018860	S.CER ECJ0EB0J105K	B	47.4/32.1
C375	4030017460	S.CER ECJ0EB1E102K	B	100/14.7
C376	4030017420	S.CER ECJ0EC1H470J	T	95.5/14.3
C377	4030017460	S.CER ECJ0EB1E102K	B	26.6/24.2
C379	4030017460	S.CER ECJ0EB1E102K	B	87.3/5.4
C384	4030018100	S.CER ECJ0EB1H681K	T	61.7/15.5
C386	4030016930	S.CER ECJ0EB1A104K	T	58.6/13.3
C387	4030016930	S.CER ECJ0EB1A104K	T	60.9/14.6
C388	4030016930	S.CER ECJ0EB1A104K	T	60.9/13.7
C390	4030016930	S.CER ECJ0EB1A104K	T	78/18.8
C393	4030016930	S.CER ECJ0EB1A104K	T	78/15.6
C394	4030016930	S.CER ECJ0EB1A104K	T	70.6/15.2
C395	4030016930	S.CER ECJ0EB1A104K	T	92.6/34.2
C396	4030017630	S.CER ECJ0EC1H120J	B	90.9/19.3
C397	4030017630	S.CER ECJ0EC1H120J	B	90.9/20.4
C398	4030017460	S.CER ECJ0EB1E102K	T	70.3/34.8
C399	4550007120	S.TAN F92 1D 224MPA	T	67.9/33.9
C400	4030017460	S.CER ECJ0EB1E102K	T	71/24.5
C401	4030018860	S.CER ECJ0EB0J105K	T	71/23.6
C402	4030017460	S.CER ECJ0EB1E102K	T	97.2/26.7
C406	4030016930	S.CER ECJ0EB1A104K	B	45.2/42.9
C409	4030016930	S.CER ECJ0EB1A104K	B	14.7/34.4
C410	4030016930	S.CER ECJ0EB1A104K	B	11.4/34.4
C412	4030017420	S.CER ECJ0EC1H470J	T	80.5/6.4
C413	4030018110	S.CER ECJ0EB1H272K	T	76.3/18.8
C420	4030017350	S.CER ECJ0EC1H020B	T	86.1/20.7
C421	4550006780	S.TAN TEESVB2 0J 476M8R	B	30.2/41.3
C422	4550006780	S.TAN TEESVB2 0J 476M8R	B	53.5/16.4
C423	4030017730	S.CER ECJ0EB1E471K	B	94.5/25.3
C424	4030016790	S.CER ECJ0EB1C103K	B	60.2/22.5
C430	4030016930	S.CER ECJ0EB1A104K	B	28.3/8
C432	4030016930	S.CER ECJ0EB1A104K	B	60.2/28.7
C433	4030016930	S.CER ECJ0EB1A104K	B	27.3/12.4
C435	4030017910	S.CER ECJ0EB1H152K	T	71/20.7
C436	4030017910	S.CER ECJ0EB1H152K	T	71/22.5
C437	4030017640	S.CER ECJ0EC1H150J	B	87.6/38.8
C438	4030017660	S.CER ECJ0EC1H330J	B	88.1/27.4
C439	4030017460	S.CER ECJ0EB1E102K	B	89.4/27.4
C440	4030017460	S.CER ECJ0EB1E102K	T	67.2/5.4
C441	4030017460	S.CER ECJ0EB1E102K	B	83.5/31.9
C442	4030017460	S.CER ECJ0EB1E102K	B	83.5/35.5
C443	4030017510	S.CER ECJ0EC1H680J	B	88.1/28.9
C444	4030017460	S.CER ECJ0EB1E102K	B	78.6/25.8

[A]=USA-02 (F3021T) [B]=EUR-02 (F3022T) [C]=GEN-02 (F3023T)
 [D]=USA-02 (F3021S) [E]=EUR-02 (F3022S) [F]=GEN-02 (F3023S)

[MAIN UNIT]

REF NO.	ORDER NO.	DESCRIPTION	M.	H/V LOCATION
J2	6450002250	CNR HSJ1456-010320		
J3	6450000131	CNR HSJ1102-018540		
J5	6510025220	S.CNR AXK540145J	B	16.3/10.3
DS1	5010000160	S.LED LNJ310M6URA	T	57.3/5.9
DS2	5010000160	S.LED LNJ310M6URA	T	57.3/40.3
DS3	5030002760	LCD L3-0200HAY3 (-4)		
MC1	7700002480	MIC SKB-2746 LPC		
S1	2230001060	S.SW EVQ-PUL 02K	T	102.2/36.1
S2	2260002840	SW SKHLLFA010		
S3	2260002800	S.SW SW-167 (SKQTLAE010)	B	61.1/44.2
S4	2260002800	S.SW SW-167 (SKQTLAE010)	B	51.6/44.2
S5	2260002800	S.SW SW-167 (SKQTLAE010)	B	99.6/44.2
EP1	6910015370	S.BEA ACZ1005Y-102-T	B	73.5/26.9
EP3	6910015370	S.BEA ACZ1005Y-102-T	B	58.4/36.3
EP6	6910015370	S.BEA ACZ1005Y-102-T	T	79.5/28
EP7	8930063020	LCT SRCN-2721-SP-N-W		
EP11	6910015370	S.BEA ACZ1005Y-102-T	T	75.7/3.1

[PA UNIT]

REF NO.	ORDER NO.	DESCRIPTION	M.	H/V LOCATION
IC701	1110002751	S.IC TA75S01F (TE85R F)	B	18.9/22.9
Q701	1560001231	S.FET RD07MVS1-T112	B	22.6/8.3
Q702	1560001241	S.FET RD01MUS1-T113	B	16/8.3
Q704	1530003260	S.TR 2SC5006-T	T	6.7/11.9
Q705	1590002160	S.TR XP6401-(TX)	T	19.9/22.7
Q706	1530002060	S.TR 2SC4081 T106 R	T	21/19.8
D701	1750000581	S.DIO 1SV307 (TPH3 F)	T	33.9/12.8
D702	1790001670	S.DIO RB706F-40T106	T	28.8/17.8
D703	1790001670	S.DIO RB706F-40T106	B	31.2/12.7
D704	1750000581	S.DIO 1SV307 (TPH3 F)	B	28.8/15.8
D706	1750000581	S.DIO 1SV307 (TPH3 F)	B	30.6/16.3
L701	6200002861	S.COL NLV25T-4R7J	B	35.9/14.9
L702	6200007891	S.COL ELJRF 27NJFB	B	18.8/12
L703	6200008490	S.COL 0.30-0.9-3TR 7.5N	T	28/13.7
L704	6200008510	S.COL 0.30-0.9-4TR 10.5N	T	24.2/14
L705	6200009760	S.COL 0.30-0.9-9TR	T	19.2/13.7
L706	6200003590	S.COL EXCCL3225U1	T	17.4/17
L707	6200010991	S.COL ELJRF 47NJFB	T	5.4/14
L708	6200008280	S.COL 0.30-1.7-TTL 50N	T	32.8/10.5
L709	6200008170	S.COL 0.35-1.6-8TL 54N	T	33.5/16.8
L712	6200009290	S.COL LQW18AN47NG00D	B	33.1/15.8
L713	6200007760	S.COL LQW2BH82NJ03L	T	28.4/20.7
L714	6200009280	S.COL LQW18AN27NG00D	B	28.7/18
R701	7030003380	S.RES ERJ3GEYJ 331 V (330)	B	34.1/11.4
R702	7030003380	S.RES ERJ3GEYJ 331 V (330)	B	34.1/12.7
R703	7030005040	S.RES ERJ2GEJ 472 X (4.7 k)	T	25.3/17.5
R704	7030007250	S.RES ERJ2GEJ 220 X (22)	B	19.3/5.2
R705	7030005090	S.RES ERJ2GEJ 104 X (100 k)	T	18.7/2.5
R706	7030005040	S.RES ERJ2GEJ 472 X (4.7 k)	T	18.7/1.6
R708	7030005590	S.RES ERJ2GEJ 680 X (68)	B	12/11.1
R709	7030005220	S.RES ERJ2GEJ 223 X (22 k)	B	9.8/10.9
R710	7030005040	S.RES ERJ2GEJ 472 X (4.7 k)	B	8.7/10.9
R711	7030005060	S.RES ERJ2GEJ 333 X (33 k)	T	22.4/17.5
R712	7030005120	S.RES ERJ2GEJ 102 X (1 k)	T	20.4/17.5
R713	7030005120	S.RES ERJ2GEJ 102 X (1 k)	T	17.4/23.9
R714	7030007330	S.RES ERJ1WRSJR15U (0.15)	T	14/21.4
R715	7030005000	S.RES ERJ2GEJ 471 X (470)	T	6.2/8.3
R716	7030005050	S.RES ERJ2GEJ 103 X (10 k)	T	22.7/22.7
R726	7030005040	S.RES ERJ2GEJ 472 X (4.7 k)	B	28.8/13.7
R730	7030007290	S.RES ERJ2GEJ 222 X (22 k)	T	7.2/8.3
R732	7030004980	S.RES ERJ2GEJ 101 X (100)	T	6.2/9.9
R734	7030010040	S.RES ERJ2GEJ-JPW	B	8.7/12.1
R735	7030010040	S.RES ERJ2GEJ-JPW	B	10.3/12.1
R738	7030004980	S.RES ERJ2GEJ 101 X (100)	B	17.8/12
R741	7030005530	S.RES ERJ2GEJ 100 X (10)	B	15.7/24.2
R742	7030007570	S.RES ERJ2GEJ 122 X (1.2 k)	B	22.2/21.5
R743	7030007340	S.RES ERJ2GEJ 153 X (15 k)	B	21.2/21.5
R744	7030005310	S.RES ERJ2GEJ 124 X (120 k)	B	22.2/23.7
R745	7030005110	S.RES ERJ2GEJ 22 X (220 k)	B	19.5/19.7
R746	7030004990	S.RES ERJ2GEJ 221 X (220)	B	17.8/20.7

M.=Mounted side (T: Mounted on the Top side, B: Mounted on the Bottom side)
 S.=Surface mount

[PA UNIT]

REF NO.	ORDER NO.	DESCRIPTION	M.	H/V LOCATION
C701	4030017460	S.CER ECJ0EB1E102K	T	35/11
C702	4030017430	S.CER ECJ0EC1H101J	B	33.8/10
C703	4030017420	S.CER ECJ0EC1H470J	B	34.8/10
C704	4030017390	S.CER ECJ0EC1H180J	B	32.3/10
C705	4030007040	S.CER C1608 CH 1H 180J-T	T	31.3/14.5
C706	4030007050	S.CER C1608 CH 1H 220J-T	T	29.7/14
C707	4030017460	S.CER ECJ0EB1E102K	T	26.8/17.5
C708	4030017510	S.CER ECJ0EC1H680J	T	27.9/15.2
C709	4030017460	S.CER ECJ0EB1E102K	T	21.4/17.5
C710	4030017460	S.CER ECJ0EB1E102K	T	21.7/22.7
C711	4030007100	S.CER C1608 CH 1H 560J-T	T	26.2/14
C713	4030017460	S.CER ECJ0EB1E102K	B	31.3/10.3
C715	4030017420	S.CER ECJ0EC1H470J	T	15.7/13.5
C716	4030016790	S.CER ECJ0EB1C103K	T	14.7/13.5
C718	4030017460	S.CER ECJ0EB1E102K	B	18/5.1
C719	4030017460	S.CER ECJ0EB1E102K	T	13.7/13.5
C720	4030017680	S.CER ECJ0EC1H820J	B	19/8.4
C722	4030017460	S.CER ECJ0EB1E102K	B	14/12.9
C723	4030017460	S.CER ECJ0EB1E102K	B	10.8/10.9
C724	4030017460	S.CER ECJ0EB1E102K	T	19.4/18.1
C725	4030017460	S.CER ECJ0EB1E102K	T	7.2/14
C727	4030017460	S.CER ECJ0EB1E102K	T	9.9/14
C728	4030017380	S.CER ECJ0EC1H050B	T	6.3/14
C729	4030017640	S.CER ECJ0EC1H150J	B	12/12.1
C731	4030017380	S.CER ECJ0EC1H050B	T	5.2/8.3
C732	4030017460	S.CER ECJ0EB1E102K	T	11.2/18.7
C733	4030017420	S.CER ECJ0EC1H470J	B	13.9/20.2
C734	4030017460	S.CER ECJ0EB1E102K	T	16.3/2.5
C742	4030017460	S.CER ECJ0EB1E102K	T	34.1/14.2
C744	4030017640	S.CER ECJ0EC1H150J	T	31.6/16.9
C745	4030017550	S.CER ECJ0EC1H1R5B	T	35.5/16.5
C746	4030017410	S.CER ECJ0EC1H240J	T	31.3/18.4
C748	4030018860	S.CER ECJ0EB0J105K	B	14.9/12.9
C750	4030018120	S.CER ECJ0EC1H110J	B	32/15
C751	4030017630	S.CER ECJ0EC1H120J	B	32/16.7
C752	4030017460	S.CER ECJ0EB1E102K	B	26.6/17.9
C753	4030017460	S.CER ECJ0EB1E102K	B	26.8/16.4
C754	4030017460	S.CER ECJ0EB1E102K	B	29.2/12.5
C755	4030017420	S.CER ECJ0EC1H470J	B	16.7/12.9
C756	4030017420	S.CER ECJ0EC1H470J	B	15.8/12.9
C757	4030017460	S.CER ECJ0EB1E102K	T	16.7/13.5
C758	4030017420	S.CER ECJ0EC1H470J	T	16.3/1.6
C759	4030017460	S.CER ECJ0EB1E102K	B	7.6/10.9
C760	4030017460	S.CER ECJ0EB1E102K	B	21.2/19.9
C761	4030017460	S.CER ECJ0EB1E102K	T	7.2/9.9
C763	4030016790	S.CER ECJ0EB1C103K	T	8.1/14
C767	4030017460	S.CER ECJ0EB1E102K	B	16.7/14.5
C768	4030017520	S.CER ECJ0EC1H0R3B	T	29.4/15.8
C769	4030017520	S.CER ECJ0EC1H0R3B	B	34.2/16.8
C780	4030017460	S.CER ECJ0EB1E102K	B	15.7/22.6
C781	4030016930	S.CER ECJ0EB1A104K	B	16.7/24.2
C782	4030017460	S.CER ECJ0EB1E102K	B	14.7/23.7
C784	4030017420	S.CER ECJ0EC1H470J	B	19.5/20.7
C785	4030016790	S.CER ECJ0EB1C103K	B	21.2/23.7
C786	4550007600	S.TAN F920J106MPABMA	T	17.7/21.1
C787	4030017580	S.CER ECJ0EC1H060C	T	26.2/20.1
J701	6910017680	CNR IMSA-9230B-1-04Z140-PT1		
J702	6910017680	CNR IMSA-9230B-1-04Z140-PT1		
F701	5210000901	S.FUS 0467003.NR (0434003)	B	12.7/20.2
EP711	6910015370	S.BEA ACZ1005Y-102-T	T	9/14
EP712	6910012350	S.BEA MMZ1608Y 102BT	B	14.6/14.4

[CONNECT UNIT]

REF NO.	ORDER NO.	DESCRIPTION	M.	H/V LOCATION
L901	6200006190	S.COL BLM21PG300SN1D	T	8.7/6
C901	4030017460	S.CER ECJ0EB1E102K	T	5.6/6
C902	4030017420	S.CER ECJ0EC1H470J	T	5.6/7
J901	6910015881	CNR 9230B-1-02Z141-PT1		

M.=Mounted side (T: Mounted on the Top side, B: Mounted on the Bottom side)
S.=Surface mount

[ANT UNIT]

REF NO.	ORDER NO.	DESCRIPTION	M.	H/V LOCATION
L801	6200008580	S.COL 0.30-1.4-6TL 32N	T	4.2/12.3
L802	6200008280	S.COL 0.30-1.7-7TL 50N	T	3.6/8.6
R801	7030005080	S.RES ERJ2GEJ 823 X (82 k)	T	9/13.5
C801	4030017460	S.CER ECJ0EB1E102K	T	9.6/7.4
C802	4030017380	S.CER ECJ0EC1H050B	T	5.5/8.6
C803	4030017410	S.CER ECJ0EC1H240J	T	1.8/14.1
C807	4030017620	S.CER ECJ0EC1H100C	T	3.4/14.1

[A]=USA-02 (F3021T) [B]=EUR-02 (F3022T) [C]=GEN-02 (F3023T)
[D]=USA-02 (F3021S) [E]=EUR-02 (F3022S) [F]=GEN-02 (F3023S)

• BC-160 (Optional product)

[MAIN UNIT]

REF NO.	ORDER NO.	DESCRIPTION	M.	H/V LOCATION
IC1	1110006480	S.IC NJM2801U1-0543-TE1	B	10.2/62.3
IC2	1110003071	S.IC μPC494GS-E1-A	B	13/36.7
IC3	1140012301	S.IC μPD78912AMC-534-5A4-A	B	19.1/19.6
IC4	1110002700	S.IC NJM2904M-TE1	B	35.1/13.8
Q1	1530002060	S.TR 2SC4081 T106 R	B	37.3/63.9
Q2	1550000090	S.FET RSQ035P03TR	B	37.3/60.9
Q3	1530002060	S.TR 2SC4081 T106 R	B	35.8/19.3
Q4	1530002060	S.TR 2SC4081 T106 R	B	41.6/18.3
Q5	1590000430	S.TR DTC144EUA T106	B	23.7/26.6
Q6	1530002060	S.TR 2SC4081 T106 R	B	22.5/58.2
D1	1730002350	S.ZEN MA8110-M (TX)	B	17.6/60.5
D2	1750000550	S.DIO 1SS355 TE-17	B	34.8/64.4
D3	1750001110	S.DIO SM240A-T	B	44.4/56
D4	1160000070	S.DIO DAN202K T146	B	26.9/20.6
D5	1750000550	S.DIO 1SS355 TE-17	B	27.2/15
X1	6060000790	S.CER CSTCR4M91G	B	10.3/17.7
L1	6190001640	S.COL SLF12555T-101M1R1	B	35.3/52.7
L2	6200002611	S.COL NLV25T-F47J	B	20.8/28.2
R2	7030000460	S.RES MCR10EZHZJ 4.7 k	B	20.3/58.6
R3	7030003410	S.RES ERJ3GEYJ 561 V (560)	B	37.3/65.8
R4	7030003200	S.RES ERJ3GEYJ 100 V (10)	B	34.6/61.1
R5	7030009580	S.RES ERJ8RSJ R12V	B	31.8/73
R6	7030000540	S.RES MCR10EZHZJ 22 k	B	30.1/26.8
R7	7030000380	S.RES MCR10EZHZJ 1 k	B	30.1/29.6
R8	7030003520	S.RES ERJ3GEYJ 472 V (4.7 k)	B	39.5/18.4
R9	7030003600	S.RES ERJ3GEYJ 223 V (22 k)	B	13.8/30.5
R10	7030000740	S.RES MCR10EZHZJ 1 M	B	25.8/34.9
R11	7030000540	S.RES MCR10EZHZJ 22 k	B	24.8/37.8
R12	7030003560	S.RES ERJ3GEYJ 103 V (10 k)	B	10.8/30.5
R13	7030003600	S.RES ERJ3GEYJ 223 V (22 k)	B	19.3/34.5
R14	7030003770	S.RES ERJ3GEYJ 564 V (560 k)	B	21/34.5
R15	7030003650	S.RES ERJ3GEYJ 563 V (56 k)	B	21/40.3
R16	7030003770	S.RES ERJ3GEYJ 564 V (560 k)	B	19.3/40.3
R17	7030003560	S.RES ERJ3GEYJ 103 V (10 k)	B	22.7/40.3
R18	7030003410	S.RES ERJ3GEYJ 561 V (560)	B	8.6/43.5
R19	7030003620	S.RES ERJ3GEYJ 333 V (33 k)	B	16.7/42.1
R20	7030000560	S.RES MCR10EZHZJ 33 k	B	28.1/40.4
R21	7030000380	S.RES MCR10EZHZJ 1 k	B	26.3/28.6
R22	7030000440	S.RES MCR10EZHZJ 3.3 k	B	24/11.4
R23	7030000460	S.RES MCR10EZHZJ 4.7 k	B	24/8.8
R24	7030000260	S.RES MCR10EZHZJ 100 (101)	B	20.3/11.4
R25	7030000260	S.RES MCR10EZHZJ 100 (101)	B	20.3/8.8
R26	7030000500	S.RES MCR10EZHZJ 10 k	B	30.5/22
R27	7030007220	S.RES ERA3YED 202V (2 k)	B	30.2/19.6
R28	7030011200	S.RES ERA3YEB 303V (30 k)	B	30/18.1
R29	7030011190	S.RES ERA3YEB 103V (10 k)	B	26.9/16.6
R30	7030005871	S.RES ERA3YKD 104V (100 k)	B	40.4/15.1
R31	7030003560	S.RES ERJ3GEYJ 103 V (10 k)	B	29.8/15.9
R32	7030005341	S.RES ERA3YED 332V (3.3 k)	B	43.4/11.1
R33	7030000500	S.RES MCR10EZHZJ 10 k	B	31.7/9.8
R34	7030000740	S.RES MCR10EZHZJ 1 M	B	42.1/14.4
R35	7030003440	S.RES ERJ3GEYJ 102 V (1 k)	B	40.4/12.2
R36	7030000460	S.RES MCR10EZHZJ 4.7 k	B	34.7/23.8
R37	7030005501	S.RES ERA3YKD 124V (120 k)	B	33.6/21.3
R38	7030005671	S.RES ERA3YKD 393V (39 k)	B	30.1/25.1
R39	7030000010	S.RES MCR10EZHZJ JPW	B	28.1/42.2
R40	7030000010	S.RES MCR10EZHZJ JPW	B	27.7/8.4
R41	7030000010	S.RES MCR10EZHZJ JPW	B	34.6/9.2
R42	7030008240	S.RES ERJ12YJ0R00U	B	38.9/7.4
R43	7030000010	S.RES MCR10EZHZJ JPW	B	30.1/33.3
R44	7030000010	S.RES MCR10EZHZJ JPW	B	28.1/33.3
R45	7030000010	S.RES MCR10EZHZJ JPW	B	29.1/38
R46	7030000010	S.RES MCR10EZHZJ JPW	B	29.1/36.1
R47	7030000010	S.RES MCR10EZHZJ JPW	B	43.9/18.3
R48	7030008240	S.RES ERJ12YJ0R00U	B	43/28.9
R49	7030000010	S.RES MCR10EZHZJ JPW	B	23.5/5.7
R50	7030008240	S.RES ERJ12YJ0R00U	B	34.1/38.2
R51	7030000010	S.RES MCR10EZHZJ JPW	B	23.9/34.9
R52	7030000010	S.RES MCR10EZHZJ JPW	B	24.7/32
R53	7030008240	S.RES ERJ12YJ0R00U	B	38.6/33.1
R54	7030000010	S.RES MCR10EZHZJ JPW	B	34.4/33
R55	7030000010	S.RES MCR10EZHZJ JPW	B	32/60.1
R56	7030000010	S.RES MCR10EZHZJ JPW	B	42.1/41.5
R57	7030000010	S.RES MCR10EZHZJ JPW	B	37.2/41.5
R58	7030000010	S.RES MCR10EZHZJ JPW	B	24.9/57
R59	7030000010	S.RES MCR10EZHZJ JPW	B	27.6/49.3
R60	7030000010	S.RES MCR10EZHZJ JPW	B	16.3/58.3
R61	7030000010	S.RES MCR10EZHZJ JPW	B	4.9/31.7
R62	7030000010	S.RES MCR10EZHZJ JPW	B	39.1/41.5
R63	7030000010	S.RES MCR10EZHZJ JPW	B	31.4/43.6

[MAIN UNIT]

REF NO.	ORDER NO.	DESCRIPTION	M.	H/V LOCATION
R64	7030000010	S.RES MCR10EZHZJ JPW	B	40.1/38.7
R65	7030000010	S.RES MCR10EZHZJ JPW	B	4.9/49.5
R66	7030003560	S.RES ERJ3GEYJ 103 V (10 k)	B	8.2/13.6
R67	7030000100	S.RES MCR10EZHZJ 4R7 (4.7)	B	10.2/45.1
C1	4030006900	S.CER C1608 JB 1H 103K-T	B	44.5/70.7
C2	4030006900	S.CER C1608 JB 1H 103K-T	B	48.2/73.5
C3	4030006860	S.CER C1608 JB 1H 102K-T	B	44.5/67.8
C4	4030006900	S.CER C1608 JB 1H 103K-T	B	32.9/69.7
C5	4030006900	S.CER C1608 JB 1H 103K-T	B	32.9/71.1
C6	4510008540	S.ELE EEE1CA100SR	B	17.5/63.8
C7	4030011600	S.CER C1608 JB 1E 104K-T	B	13.4/60.8
C8	4030006900	S.CER C1608 JB 1H 103K-T	B	9.2/58.7
C9	4030011600	S.CER C1608 JB 1E 104K-T	B	13.4/63.8
C10	4510009150	S.ELE EEE1EA470WP	B	43.6/62.8
C11	4030006900	S.CER C1608 JB 1H 103K-T	B	35.8/67.9
C12	4030006900	S.CER C1608 JB 1H 103K-T	B	32.4/67.9
C13	4510009150	S.ELE EEE1EA470WP	B	26.5/62.8
C14	4510008660	S.ELE EEE0JA220SR	B	34.3/28
C15	4510008660	S.ELE EEE0JA220SR	B	40.8/23.8
C16	4030006860	S.CER C1608 JB 1H 102K-T	B	12.3/30.5
C17	4030011600	S.CER C1608 JB 1E 104K-T	B	19.3/37.4
C18	4030006900	S.CER C1608 JB 1H 103K-T	B	21/37.4
C19	4030006900	S.CER C1608 JB 1H 103K-T	B	13.1/42.2
C20	4030009980	S.CER C1608 JB 1H 152K-T	B	8.6/42.1
C21	4030011600	S.CER C1608 JB 1E 104K-T	B	9.5/21.9
C22	4030006900	S.CER C1608 JB 1H 103K-T	B	19/25.5
C23	4030006900	S.CER C1608 JB 1H 103K-T	B	26.9/23.2
C24	4030006900	S.CER C1608 JB 1H 103K-T	B	26.9/18
C25	4030004760	S.CER C2012 JF 1H 104Z-T	B	33.2/17.5
C26	4030006900	S.CER C1608 JB 1H 103K-T	B	41.9/11.1
C27	4030006900	S.CER C1608 JB 1H 103K-T	B	29.5/12.6
C28	4030006900	S.CER C1608 JB 1H 103K-T	B	30.1/23.7
J1	6510024940	CNR HEC2305-016250		
DS1	5040002740	LED RT3-03HRYG		

M.=Mounted side (T: Mounted on the Top side, B: Mounted on the Bottom side)
S.=Surface mount

SECTION 8 MECHANICAL PARTS AND DISASSEMBLY

[CHASSIS PARTS]

REF. NO.	ORDER NO.	DESCRIPTION	QTY.
J1	6910015910	Connector ANT connector-104	1
J2	6910015860	Connector IMSA-6277S-02A-G	1
SP1	2510001060	Speaker K036NA500-47	1
W1	8900009640	Cable OPC-963	1
MP1	8010020410	2927 chassis	1
MP2	8210022970	2927 T-front panel assembly [10-key]	1
	8210022980	2927 S-front panel assembly [4-key]	1
MP8	8210020550	2721 rear panel	1
MP9	8310066450	2927 window plate	1
MP10	8930069510	2927 window sheet	1
MP12	8930069490	2927 keyboard [10-key]	1
	8930069700	2927 4-key [4-key]	1
MP13	8930069500	2927 main seal	1
MP14	8930063060	2721 T-rubber	1
MP16	8930069460	2927 side plate	1
MP17	8930069470	2927 top plate	1
MP20	8930061880	2721 MIC sponge	1
MP21	8930059360	2600 release button	1
MP22	8930070360	2775 release plate (A)	1
MP24	8610012970	Knob N350	1
MP25	8830002900	2927 ANT nut	1
MP26	8810009561	Screw PH BT M2 x 6 NI-ZK3	2
MP27	8810009221	Screw PH BT M2 x 8 NI-ZK3	2
MP28	8810008641	Screw FH BT M2 x 4 NI-ZC3	11
MP31	8810010430	Screw trass M3 x 5 SUS SSBC	1
MP32	8310066810	2927 option plate	1
MP33	8930046020	1123 sheet (A)-1	1
MP34	8930056540	Push spring (AH)	2
MP35	8830001700	VR nut (Q)	1
MP36	8930048870	2056 A-sponge	1
MP37	8930070010	2893 VOL rubber	1

[MAIN UNIT]

REF. NO.	ORDER NO.	DESCRIPTION	QTY.
J2	6450002250	Connector HSJ1456-010320	1
J3	6450000131	Connector HSJ1102-018540	1
R315	7210003061	Variable resistor TP76N00N-15F-A103-2251A	1
DS3	5030002760	LCD L3-0200HAY-3	1
MC1	7700002480	Microphone SKB-2746 LPC	1
S2	2260002840	Switch SKHLLFA010	1
EP7	8930063020	LCD contact SRCN-2721-SP-N-W	2
MP1	8510016130	2721 VCO case	1
MP2	8510016120	2721 VCO cover	1
MP3	8930069480	2927 LCD holder	1
MP4	8210020570	2721 reflector	1
MP5	8930070080	White sheet (V)	1
MP6	8510017720	2927 main shield	1
MP9	8930070700	Insulation sheet (LQ)	1

[PA UNIT]

REF. NO.	ORDER NO.	DESCRIPTION	QTY.
J701	6910017680	Connector IMSA-9230B-1-04Z140-PT1	1
J702	6910017680	Connector IMSA-9230B-1-04Z140-PT1	1
MP701*	8410002530	2681 PA heatsink	1

[ANT UNIT]

REF. NO.	ORDER NO.	DESCRIPTION	QTY.
MP801	8510017640	2927 ANT plate	1

[CONNECT UNIT]

REF. NO.	ORDER NO.	DESCRIPTION	QTY.
J901	6910015881	Connector 9230B-1-02Z141-PT1	1

[ACCESSORIES]

REF. NO.	ORDER NO.	DESCRIPTION	QTY.
EP1	Optional product	Antenna FA-SC55V-1	1
EP2	Optional product	Battery pack BP-231	1
MP1	Optional product	Belt clip MB-94	1
MP2	8310066810	2927 option plate	1
MP3	8210022780	2927 jack panel	1
MP4	8810004861	Screw PH M2 x 6 ZK3	2

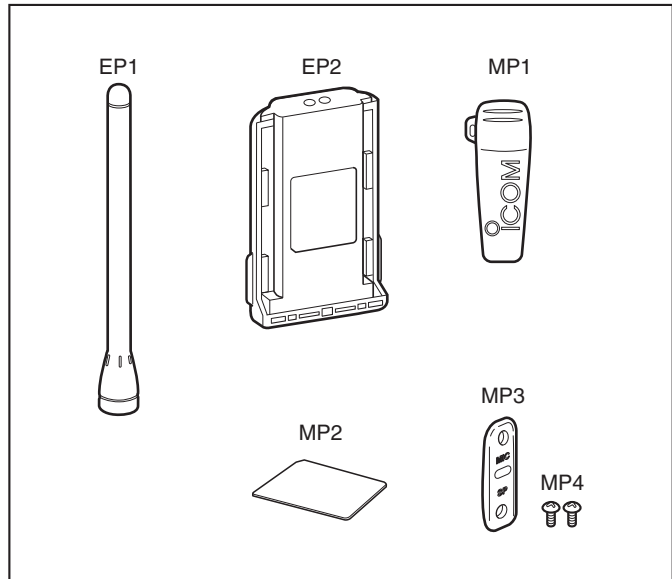

*: Refer to SECTION 10 BOARD LAYOUTS.

Screw abbreviations

BT: Self-tapping PH: Pan head
 ZK, ZK3: Black FH: Flat head
 NI: Nickel SUS: Stainless

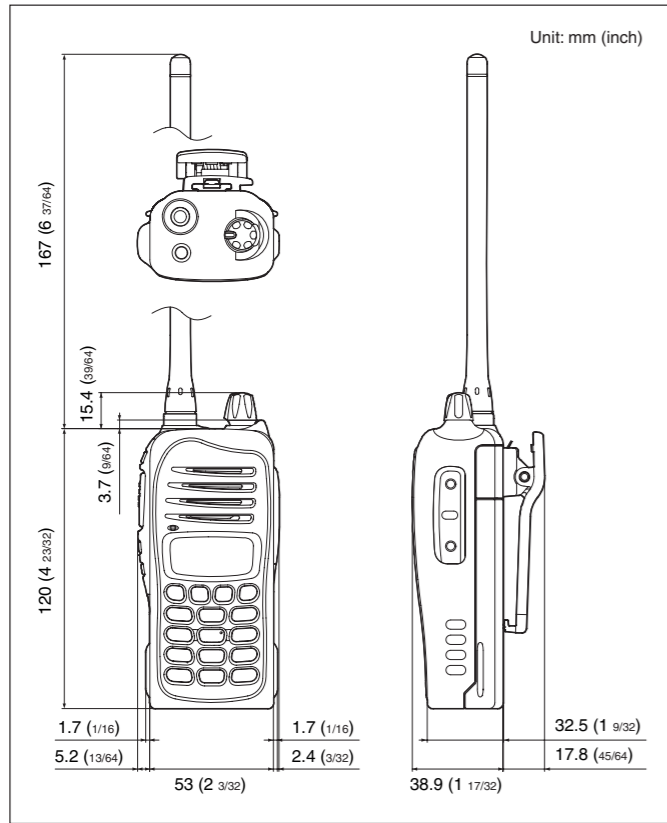

* MP2 (C), MP12 (C): The shape is depending on the version.

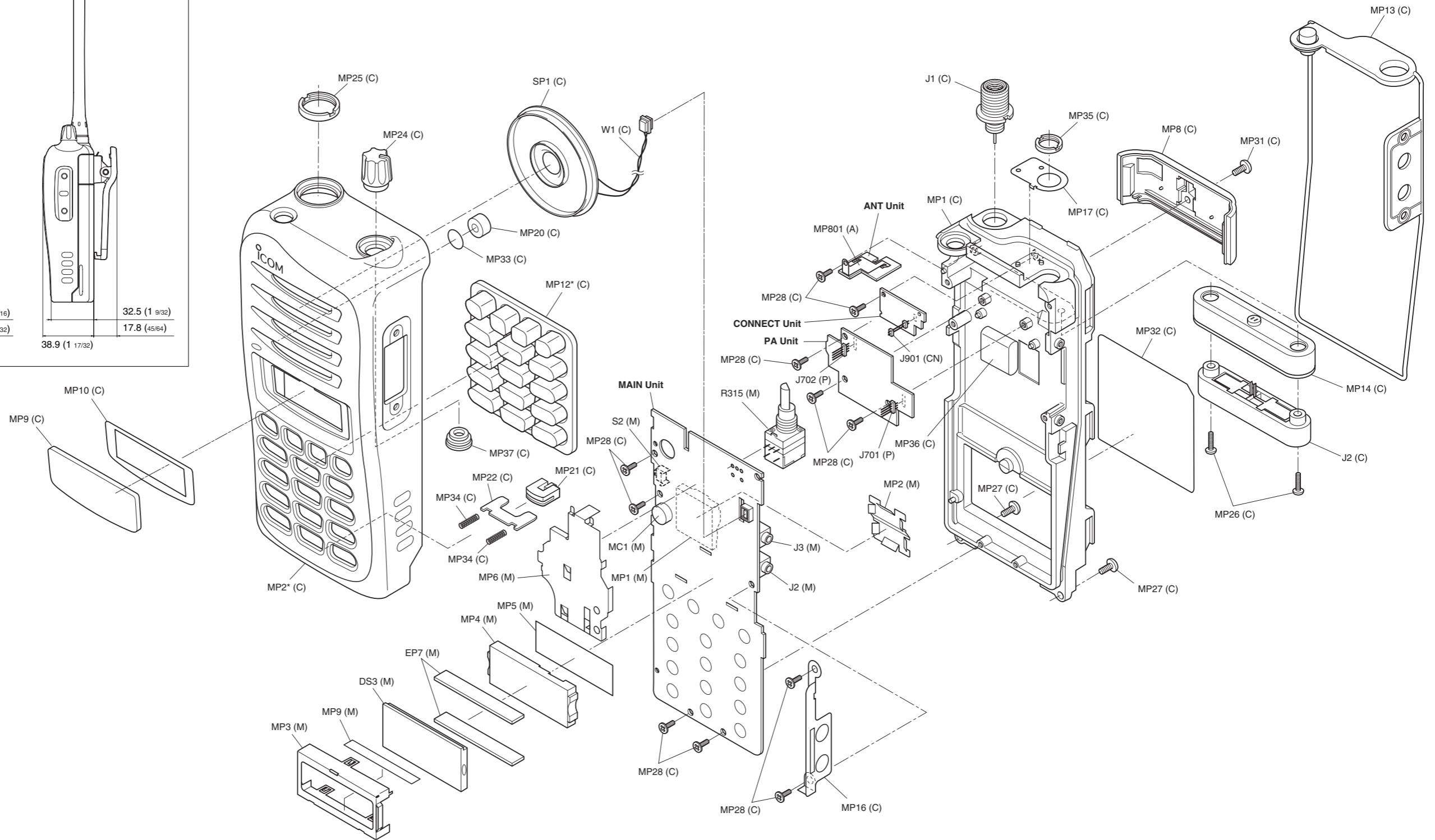

UNIT abbreviations (C): CHASSIS PARTS, (M): MAIN UNIT, (P): PA UNIT, (CN): CONNECT UNIT, (A): ANT UNIT

SECTION 9 SEMICONDUCTOR INFORMATION

• TRANSISTORS AND FET's

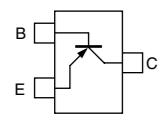
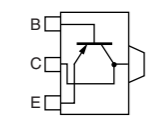
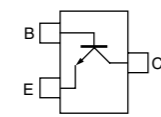
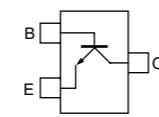
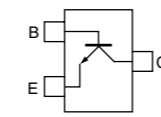
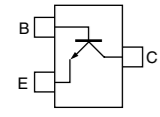
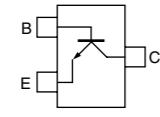
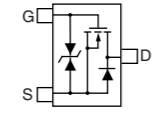
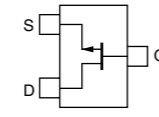
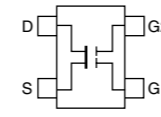
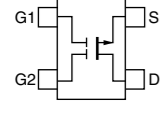
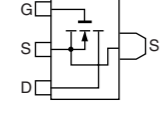
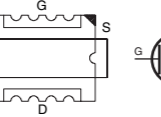
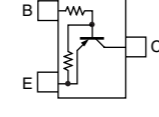
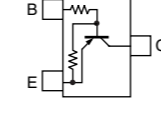
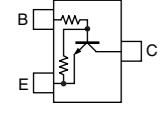
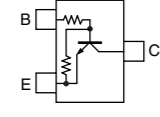
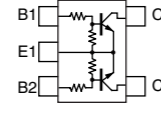
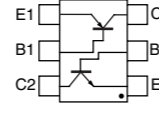
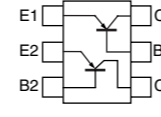
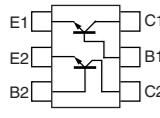
2SA1577 T106 R (Symbol: HR) 	2SB1132 T100 R (Symbol: BAR) 	2SC4081 T106 R (Symbol: BR) 	2SC4116 BL (Symbol: LL) 	2SC5006 T1 (Symbol: 24) 
2SC5107 O (Symbol: MFO) 	2SC5700 (Symbol: WB-) 	2SK3019 (Symbol: KN) 	2SK880 Y (Symbol: XY) 	3SK293 (Symbol: UF) 
3SK324UG-TL-E (Symbol: UG-) 	RD01MUS1 (Symbol: K2) 	RD07MVS1 (Symbol: RD07MVS1) 	UNR9111J (Symbol: 6A) 	UNR9113J (Symbol: 6C) 
UNR9210J (Symbol: 8L) 	UNR9213J (Symbol: 8C) 	XP1214 (Symbol: 9H) 	XP4601 (Symbol: 5C) 	XP6401 (Symbol: 5O) 
XP6501 AB (Symbol: 5N) 				

• DIODES

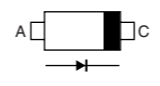
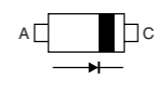
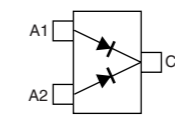
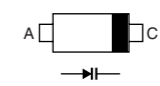
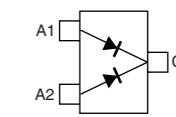
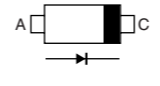
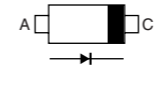
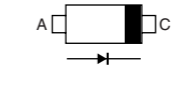
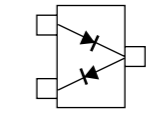
1SV239 (Symbol: TC) 	1SV307 (Symbol: TX) 	DAN222TL (Symbol: N) 	HVC375B (Symbol: B8) 	HVC376B (Symbol: B9) 
MA2S077 (Symbol: S) 	MA2S111 (Symbol: A) 	MA2S728 (Symbol: B) 	RB706F-40 T106 (Symbol: 3J) 	

SECTION 12 VOLTAGE DIAGRAMS

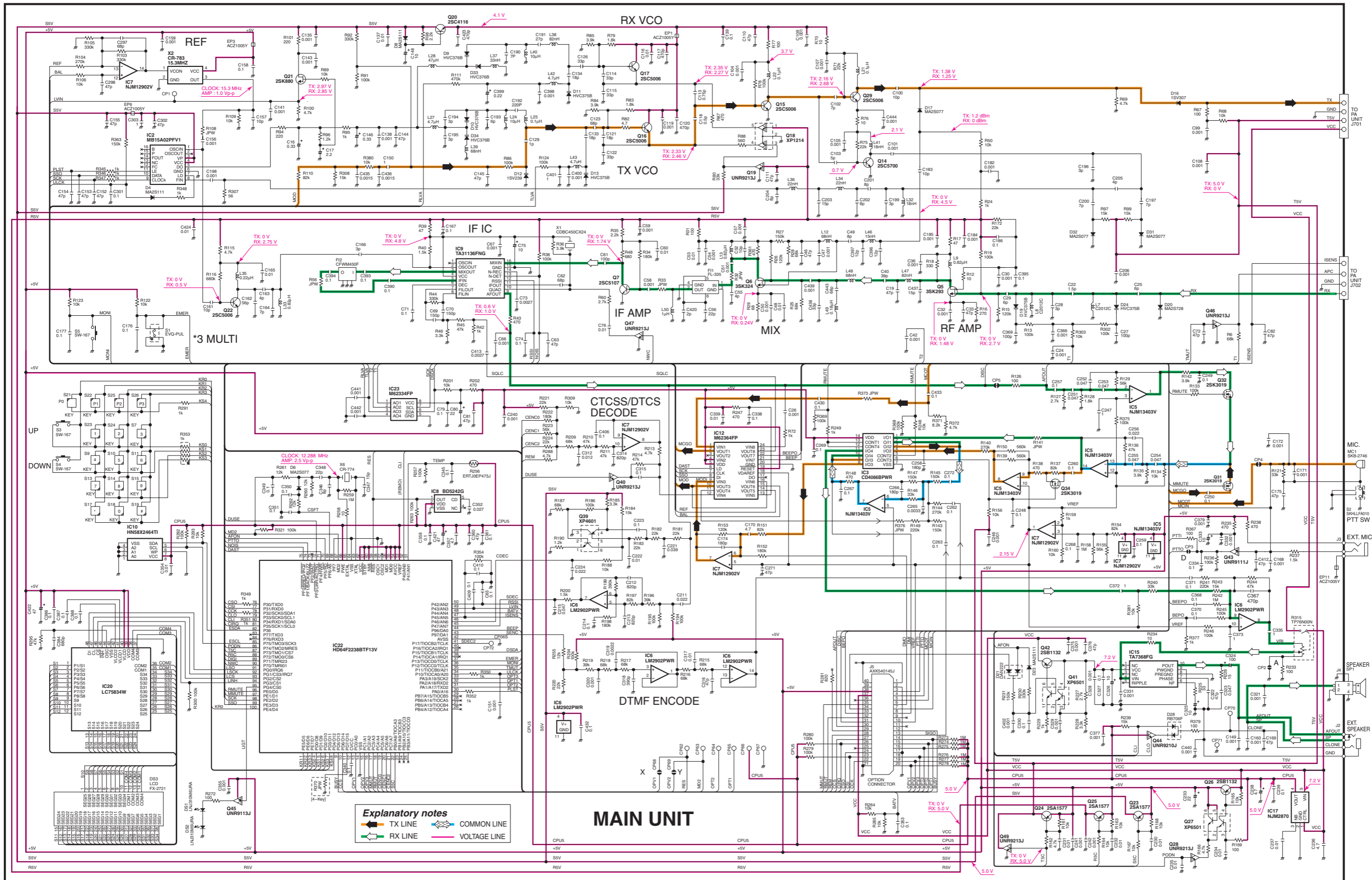

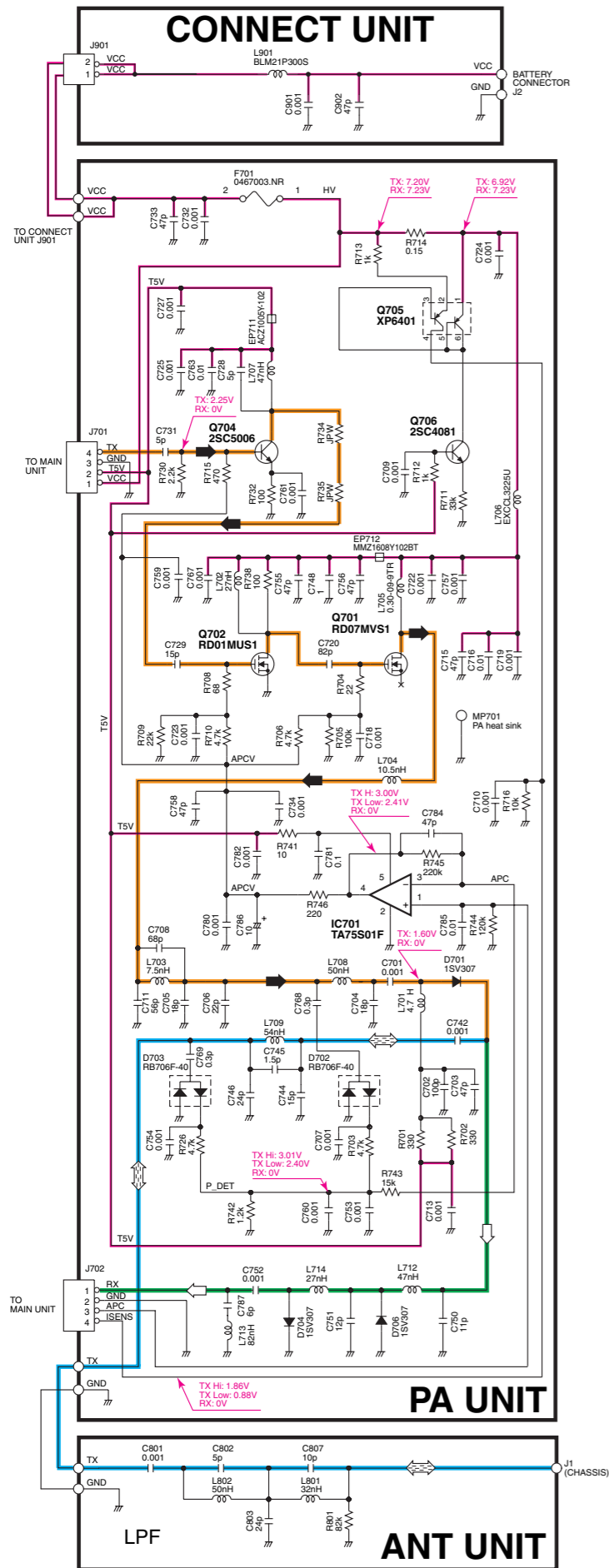

SECTION 13 BC-160

[CHASSIS PARTS]

REF. NO.	ORDER NO.	DESCRIPTION	QTY.
MP1	8010019750	2830 case	1
MP2	8110008220	2830 cover	1
MP3	8930039620	Leg cushion (A)	2
MP4	8810008630	Screw PH BT M3 x 6 NI-ZU	1

[MAIN UNIT]

REF. NO.	ORDER NO.	DESCRIPTION	QTY.
J1	6510023070	Connector HEC2305-01-250	1
DS1	5040002740	LED RT3-03HRYG	1
MP1	8930064410	2830 TERMINAL	3

[ACCESSORIES]

REF. NO.	ORDER NO.	DESCRIPTION	QTY.
EP1	0800006050	Charger BC-145A	[USA] 1
	0800006060	Charger BC-145E	[EUR] 1

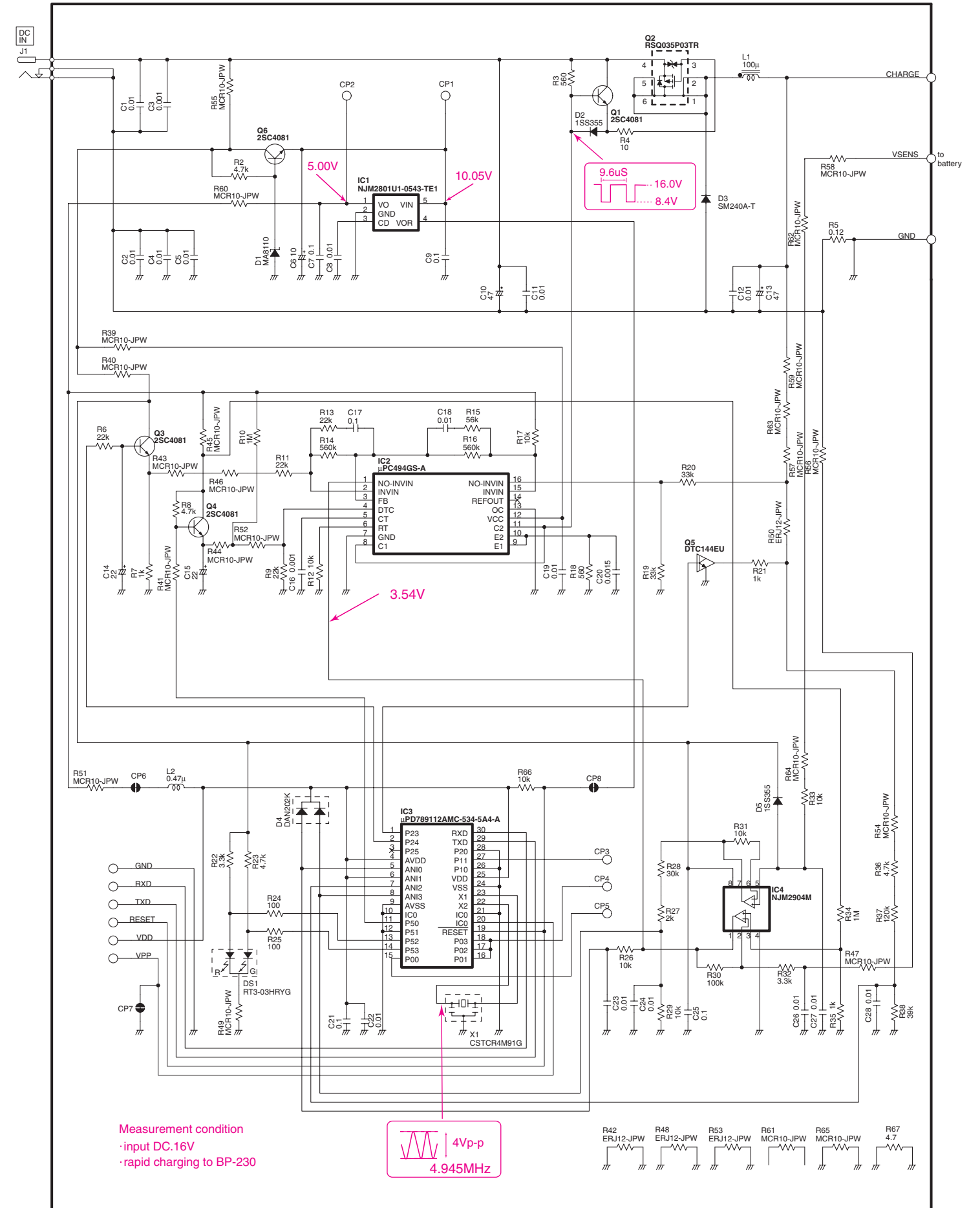
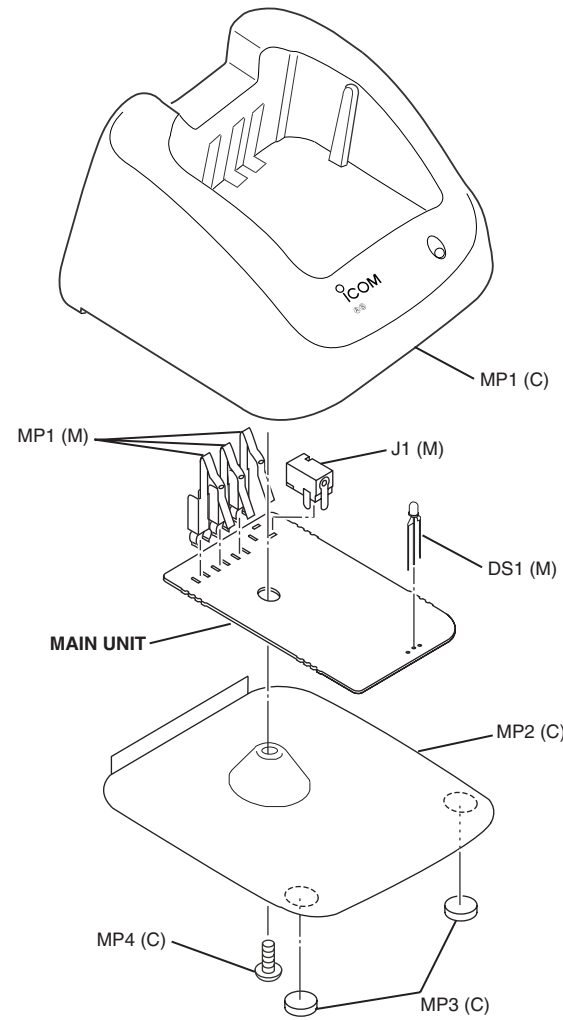

Measurement condition
 ·input DC.16V
 ·rapid charging to BP-230



Icom Inc.

1-1-32, Kamiminami, Hirano-ku, Osaka 547-0003, Japan
Phone : +81 (06) 6793 5302
Fax : +81 (06) 6793 0013
URL : <http://www.icom.co.jp/world/index.html>

Icom America Inc.

<Corporate Headquarters>
2380 116th Avenue N.E., Bellevue, WA 98004, U.S.A.
Phone : +1 (425) 454-8155 Fax : +1 (425) 454-1509
URL : <http://www.icomamerica.com>
E-mail : sales@icomamerica.com
<Customer Service>
Phone : +1 (425) 454-7619

Icom Canada

Glenwood Centre #150-6165
Highway 17 Delta, B.C., V4K 5B8, Canada
Phone : +1 (604) 952-4266 Fax : +1 (604) 952-0090
URL : <http://www.icomcanada.com>
E-mail : info@icomcanada.com

Icom (Australia) Pty. Ltd.

Unit 1 / 103 Garden Road, Clayton VIC 3168 Australia
Phone : +61 (03) 9549-7500 Fax : +61 (03) 9549-7505
URL : <http://www.icom.net.au>
E-mail : sales@icom.net.au

Icom New Zealand

146A Harris Road, East Tamaki,
Auckland, New Zealand
Phone : +64 (09) 274 4062 Fax : +64 (09) 274 4708
URL : <http://www.icom.co.nz>
E-mail : inquiries@icom.co.nz

Beijing Icom Ltd.

Room C01, 10th Floor, Long Silver Mansion, No. 88,
Yong Ding Road, Haidian District, Beijing, 100039, China
Phone : +86 (010) 5889 4250 Fax : +86 (010) 5889 4250
URL : <http://www.bjicom.com>
E-mail : bjicom@bjicom.com

Icom (Europe) GmbH

Communication Equipment
Himmelgeister Str. 100, D-40225 Düsseldorf, Germany
Phone : +49 (0211) 346047 Fax : +49 (0211) 333639
URL : <http://www.icomeurope.com>
E-mail : info@icomeurope.com

Icom Spain S.L

Ctra. Rubi, 88, 08190, Sant Cugat del Valles, Barcelona, SPAIN
Phone : +34 (93) 590 26 70 Fax : +34 (93) 589 04 46
URL : <http://www.icomspain.com>
E-mail : icom@icomspain.com

Icom (UK) Ltd.

Unit 9, Sea St., Herne Bay, Kent, CT6 8LD, U.K.
Phone : +44 (01227) 741741 Fax : +44 (01227) 741742
URL : <http://www.icomuk.co.uk>
E-mail : info@icomuk.co.uk

Icom France S.a

Zac de la Plaine, 1, Rue Brindejonc des Moulinais
BP 5804, 31505 Toulouse Cedex, France
Phone : +33 (5) 61 36 03 03 Fax : +33 (5) 61 36 03 00
URL : <http://www.icom-france.com>
E-mail : icom@icom-france.com

Asia Icom Inc.

6F No.68, Sec. 1 Cheng-Teh Road, Taipei, Taiwan, R.O.C.
Phone : +886 (02) 2559 1899 Fax : +886 (02) 2559 1874
URL : <http://www.asia-icom.com>
E-mail : sales@asia-icom.com

Icom Polska

Sopot, 3 Maja 54 Poland
Phone : +48 (58) 550 7135 Fax : +48 (58) 551 0484
E-mail : icompolska@icompolska.com.pl

Count on us!