

# Product Manual

## ESC1000 – Downlight/LED Smart Connector

### PRODUCT DESCRIPTION

The DC Smart Connector is a wireless device which provides electrical connectivity between the light fixture (load) and 24V DC power and provides on/off power control and dimming signals to the load. The information that tells the connector to power on/off/dim the fixture is acquired via wireless signals that originate from a building automation system or from room controls, based on environmental conditions and/or predetermined programs.

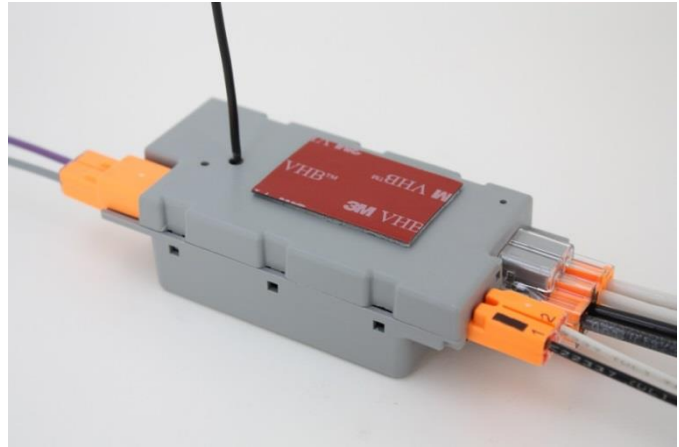

### KEY FEATURES

- FCC and IC approved
- Small form factor
- Integrated Wire Antenna
- RoHS compliant

### PRODUCT CONTENTS

The following items are included inside the package:

Qty	Description
1	ESC1000 Smart Connector

**Audacy®, Smart Connector® and Smart Switch® are registered trademarks of IDEAL INDUSTRIES.  
 All other trademarks are the property of their respective owners.**

# Product Manual

## ESC1000 – Downlight/LED Smart Connector

### IDEAL Model ESC1000 LED Smart Connector Installation Instructions

**WARNING:** This is a current rated device. Use in applications involving Amperage beyond its rating can be dangerous and cause electrical fires.

Wiring must comply with all applicable electrical codes.  
 Turn off power before removing or installing connector.

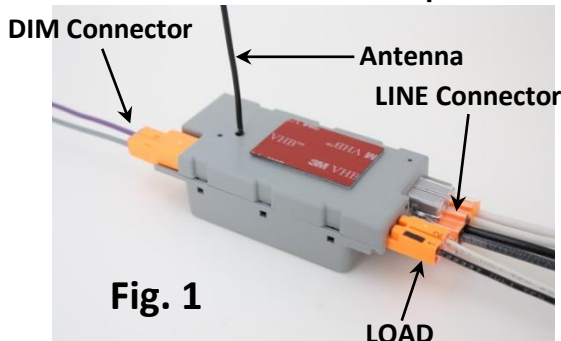

**Fig. 1**

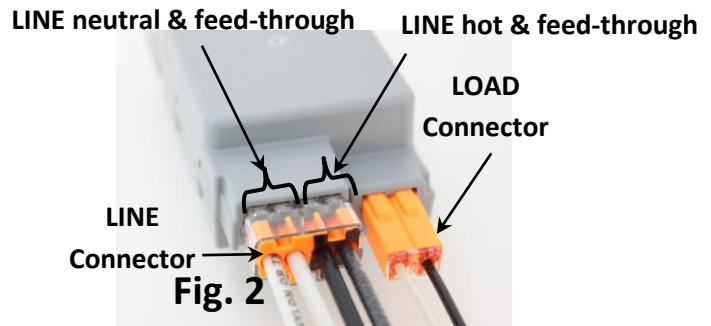

**Fig. 2**

### TERMINOLOGY

**24V Input:** Incoming power feed from 24V source (DC Flex-Zone)

**LOAD:** Power output from Smart Connector to 24V DC LED Fixture input

**DIM:** 0-10 VDC dimming control output from Smart Connector to LED Fixture dimming input

### CONNECTING THE WIRES

#### Power

The 24V Input Connector accepts 12 AWG-18 AWG copper conductors, solid or stranded (19 strands or less for 12 AWG-16 AWG, 7 strands or less for 18 AWG).

Use only one conductor per port and ensure that no copper is exposed on any of the wires after installation.

1. Strip wires to 1/2".
2. Grip +24V wire and firmly push conductor into one of the black LINE ports. See Fig. 2.
3. Grip -24V wire and firmly push conductor into one of the unmarked LINE ports. See Fig. 2.
4. For feed-through (i.e., "daisy-chain") installations, insert the +24V feed-through conductor into the other black line port. Insert the -24V feed-through conductor into the other unmarked LINE port. See Fig. 2.
5. After 24V wire installation, the supply power can safely be disconnected and re-connected without re-installing the wires. To disconnect the supply power, firmly grip the LINE connector and pull to separate it from the main body of the Smart Connector. To re-connect, simply push the LINE connector into the corresponding port on the Smart

# Product Manual

## ESC1000 – Downlight/LED Smart Connector

Connector.

### LOAD Connector

The **LOAD Connector** accepts 18 AWG copper conductors, solid or stranded (16 strands or less).

**Use only one conductor per port and ensure that no copper is exposed on any of the wires after installation.**

1. Strip the wires to 3/8”.
2. Grip the LOAD +24V wire and firmly push conductor into the port marked with the black stripe. See Fig. 2.
3. Grip the LOAD -24V wire and firmly push conductor into the unmarked port. See Fig. 2.
4. After LOAD wire installation, the load can safely be disconnected and re-connected without re-installing the wires. To disconnect the load, firmly grip the LOAD connector and pull to separate it from the main body of the Smart Connector. To re-connect, simply push the LOAD connector into the corresponding port on the Smart Connector.

### DIM Connector

The **DIM Connector** accepts 18 AWG copper conductors, solid or stranded (16 strands or less).

**Use only one conductor per port and ensure that no copper is exposed on any of the wires after installation.**

1. Strip wires to 3/8”.
2. Grip positive/(+)/purple DIM conductor and firmly push into the port marked “1”. See Fig. 3.
3. Grip negative/(-)/gray DIM conductor and firmly push into the port marked “2”. See Fig. 3.
4. After DIM wire installation, the DIM connector can safely be disconnected and re-connected without re-installing the wires. To disconnect the DIM connector, firmly grip the DIM connector and pull to separate it from the main body of the Smart Connector. To re-connect, simply push the DIM connector into the corresponding port on the Smart Connector.

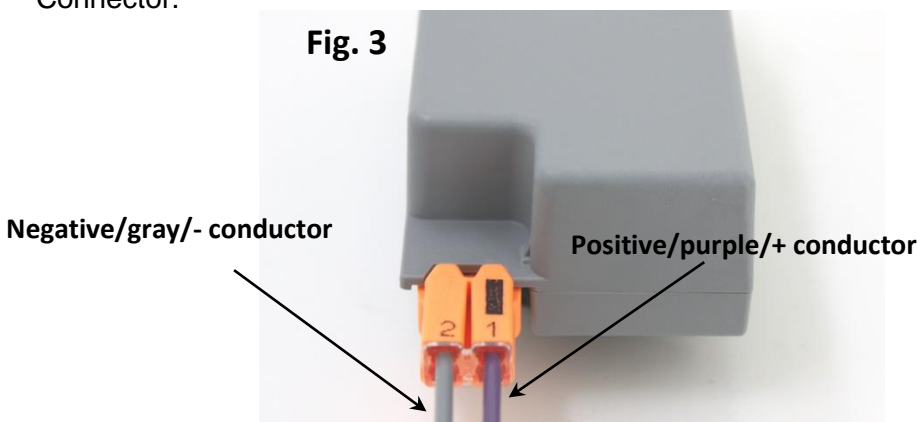

# Product Manual

## ESC1000 – Downlight/LED Smart Connector

---

### INSTALLING THE ESC1000 SMART CONNECTOR IN THE FIXTURE

1. After properly installing all wires per the instructions, fully extend the antenna. See Fig. 1.
2. Remove the backing of the double-sided tape on the ESC1000, exposing the adhesive.
3. Insert the antenna through an available open hole in the fixture trough, making sure that as much of the antenna extends into the plenum space above the fixture as possible. See Fig. 4.
4. Firmly press the connector into place.

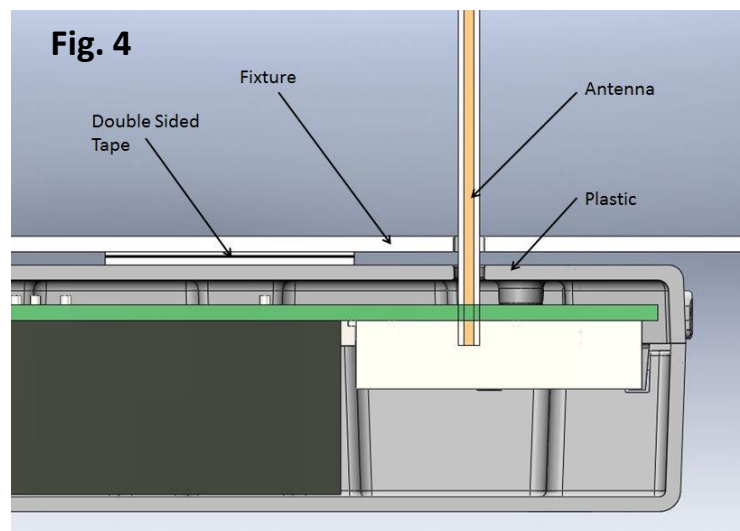

### PROGRAMMING

# Product Manual

## ESC1000 – Downlight/LED Smart Connector

---

Refer to the Audacy™ system configuration manual to associate smart connectors to other devices and to set up operating parameters for the Audacy™ lighting control system

### SPECIFICATIONS

Item	Description
Radio	915 MHz External Antenna
Regulatory Approvals	FCC Part 15 and Industry Canada Contains FCC ID: 2AAMXESC1000 Contains IC: 11250A-ESC1000 UL916
Transmit Range	300 ft. indoors line of sight to an Audacy Gateway or Smart Connector
Load Dimming	0-10VDC (10%-100%)
Load Amperage	3.96A
Switching Cycles	50,000
Power	24 VDC
Operating Temperature	0°C to 70°C
Storage Temperature	-20°C to 90°C
Installation Environment	Indoor use only
Dimensions	4.67"x1.75"x0.99"
Weight	3.3 oz
Warranty	1 yr

### MECHANICAL DIMENSIONS

# Product Manual

## ESC1000 – Downlight/LED Smart Connector

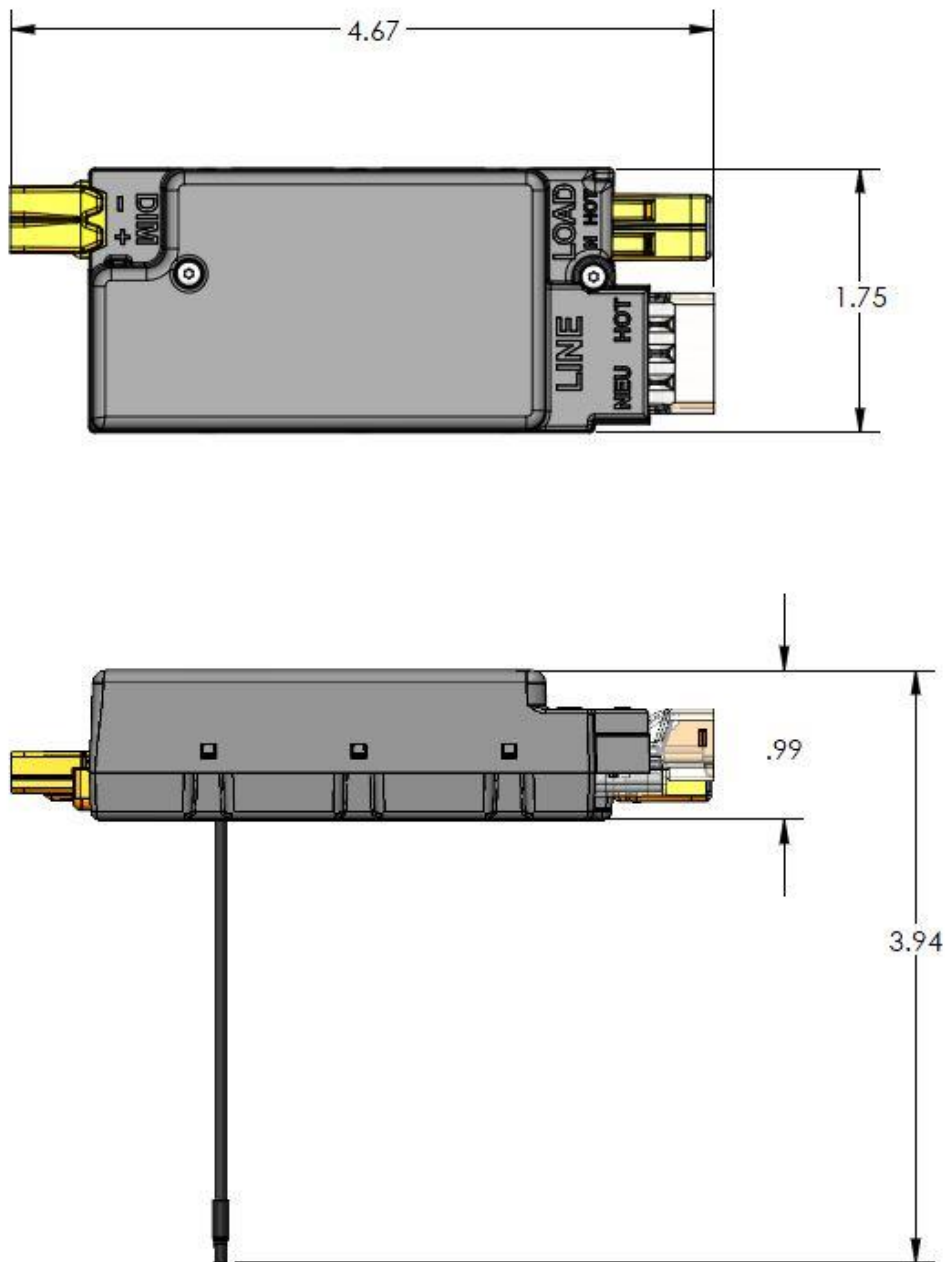

\*Dimensions in inches

# Product Manual

## ESC1000 – Downlight/LED Smart Connector

---

### SUPPORT

Technical support for IDEAL INDUSTRIES products can be initiated through the following methods:

Website: <http://www.idealindustries.com/support/>

Telephone: +1 800-435-0705

Email: [contactus@idealindustries.com](mailto:contactus@idealindustries.com)

# Product Manual

## ESC1000 – Downlight/LED Smart Connector

---

### COMPLIANCE STATEMENTS

This device is intended for commercial and industrial applications.

Changes or modifications not expressly approved by IDEAL could void the user's authority to operate the equipment. Use and maintain device only as specified in this manual.

This equipment has been tested and found to comply with the limits for a Class B digital device, pursuant to Part 15 of the FCC Rules. These limits are designed to provide reasonable protection against harmful interference in a residential installation. This equipment generates, uses, and can radiate radio frequency energy and, if not installed and used in accordance with the instructions, may cause harmful interference to radio communications. However, there is no guarantee that interference will not occur in a particular installation. If this equipment does cause harmful interference to radio or television reception, which can be determined by turning the equipment off and on, the user is encouraged to try to correct the interference by one of the following measures:

- Reorient or relocate the receiving antenna.
- Increase the separation between the equipment and receiver.
- Connect the equipment into an outlet on a circuit different from that to which the receiver is connected.
- Consult the dealer or an experienced radio/TV technician for help.

### WARNING!

#### FCC and IC Radiation Exposure Statement:

This equipment complies with FCC's and IC's RF radiation exposure limits set forth for an uncontrolled environment under the following conditions:

1. This equipment should be installed and operated such that a minimum separation distance of 20cm is maintained between the radiator (antenna) & user's/nearby person's body at all times.
2. This transmitter must not be co-located or operating in conjunction with any other antenna or transmitter.

*This device complied with Industry Canada licence-exempt RSS standard(s) and part 15 of the FCC Rules. Operation is subject to the following two conditions: (1) this device may not cause interference, and (2) this device must accept any interference, including interference that may cause undesired operation of the device.*

*Ce dispositif conforme à Industrie Canada exempts de licence standard RSS (s) et la partie 15 des règles de la FCC. Son fonctionnement est soumis aux deux conditions suivantes: (1) cet appareil ne peut pas provoquer d'interférences, et (2) ce dispositif doit accepter toute interférence, y compris les interférences qui peuvent entraîner un mauvais fonctionnement de l'appareil.*



# Product Manual

## ESC1000 – Downlight/LED Smart Connector

---

### IMPORTANT NOTICE

Information furnished by IDEAL INDUSTRIES, INC. is believed to be accurate and reliable. No license, express or implied, to any intellectual property rights is granted by this document. No responsibility is assumed by IDEAL INDUSTRIES, INC. for its use, nor for any infringements of patents or other rights of third parties that may result from its use. IDEAL INDUSTRIES, INC. assumes no liability for misuse of this product. Specifications are subject to change without notice.

No license is granted by implication or otherwise under any patent or patent rights of IDEAL INDUSTRIES, INC. Trademarks and registered trademarks are the property of their respective owners.

IDEAL INDUSTRIES, INC. PRODUCTS (INCLUDING HARDWARE AND/OR SOFTWARE) ARE NOT DESIGNED OR INTENDED TO BE FAIL-SAFE, FAULT TOLERANT OR FOR USE IN ANY APPLICATION THAT COULD LEAD TO DEATH, PERSONAL INJURY OR SEVERE PROPERTY OR ENVIRONMENTAL DAMAGE (INDIVIDUALLY AND COLLECTIVELY, “CRITICAL APPLICATIONS”), SUCH AS LIFE-SUPPORT OR SAFETY DEVICES OR SYSTEMS, CLASS III MEDICAL DEVICES, NUCLEAR FACILITIES, APPLICATIONS THAT AFFECT CONTROL OF A VEHICLE OR AIRCRAFT, APPLICATIONS RELATED TO THE DEPLOYMENT OF AIRBAGS, OR ANY OTHER CRITICAL APPLICATIONS. CUSTOMER AGREES, PRIOR TO USING OR DISTRIBUTING ANY SYSTEMS THAT INCORPORATE IDEAL INDUSTRIES, INC. PRODUCTS, TO THOROUGHLY TEST THE SAME FOR SAFETY PURPOSES. CUSTOMER ASSUMES THE SOLE RISK AND LIABILITY OF ANY USE OF IDEAL INDUSTRIES, INC. PRODUCTS IN CRITICAL APPLICATIONS, SUBJECT ONLY TO APPLICABLE LAWS AND REGULATIONS GOVERNING LIMITATIONS ON PRODUCT LIABILITY.

# Product Manual

## ESC1000 – Downlight/LED Smart Connector

---

### WARRANTY

THIS LIMITED WARRANTY applies solely to standard transmitters manufactured by or on behalf of IDEAL. Subject to the limitations herein, IDEAL warrants that transmitters, when delivered by IDEAL or its authorized distributor, for one (1) year following the delivery date, will be free from defects in material and workmanship and will substantially conform to IDEAL publicly available specifications for such products in effect at the time of delivery. This limited warranty excludes: (i) engineering samples (which are provided “AS-IS” without warranty); (ii) bare circuit boards (iii) development products (such as boards and cables); (iv) design defects or errors known as “errata”; (v) transmitters procured through unauthorized third parties; and (vi) transmitters that have been subject to misuse, mishandling, accident, alteration, neglect, unauthorized repair or installation. Furthermore, this limited warranty shall not apply to the use of covered products in an application or environment that is not within IDEAL specifications or in the event of any act, error, neglect or default of Customer. If such IDEAL products fail to conform to the warranty above, the exclusive remedy of Customer and the sole liability of IDEAL shall be, at the option of IDEAL, to replace or repair the affected products, or to refund to Customer the price of the affected products. The availability of replacement products is subject to product discontinuance policies at IDEAL. Customer may not return products without first obtaining a customer return material authorization (RMA) number from IDEAL. THE WARRANTIES SET FORTH HEREIN ARE EXCLUSIVE AND IN LIEU OF ALL OTHER WARRANTIES, REMEDIES AND CONDITIONS, WHETHER ORAL OR WRITTEN, EXPRESS OR IMPLIED. IDEAL DISCLAIMS ALL OTHER WARRANTIES, WHETHER EXPRESS, IMPLIED OR STATUTORY, INCLUDING, WITHOUT LIMITATION, ANY WARRANTY OF MERCHANTABILITY, FITNESS FOR A PARTICULAR PURPOSE, OR NON-INFRINGEMENT, AND ANY WARRANTY THAT MAY ARISE FROM COURSE OF DEALING, COURSE OF PERFORMANCE, OR USAGE OF TRADE. IF IDEAL CANNOT LAWFULLY DISCLAIM IMPLIED WARRANTIES UNDER THIS LIMITED PRODUCT WARRANTY, ALL SUCH IMPLIED WARRANTIES, INCLUDING WARRANTIES OF MERCHANTABILITY AND FITNESS FOR A PARTICULAR PURPOSE, ARE LIMITED IN DURATION TO THE WARRANTY PERIOD (AS DEFINED ABOVE). YOUR SOLE REMEDY WITH RESPECT TO ANY BREACH OF THE LIMITED PRODUCT WARRANTY SHALL BE THE REPAIR OR REPLACEMENT OF THE DEVICE AS SPECIFIED IN THE LIMITED PRODUCT WARRANTY. IDEAL IS NOT RESPONSIBLE FOR DIRECT, SPECIAL, INCIDENTAL, OR CONSEQUENTIAL DAMAGES RESULTING FROM ANY BREACH OF WARRANTY OR UNDER ANY OTHER LEGAL THEORY INCLUDING, BUT NOT LIMITED TO, LOST PROFITS, DOWNTIME, GOODWILL, DAMAGE TO OR REPLACEMENT OF EQUIPMENT AND PROPERTY, AND ANY COSTS OF RECOVERING, REPROGRAMMING, OR REPRODUCING ANY PROGRAM OR DATA STORED IN OR USED WITH A SYSTEM CONTAINING IDEAL TRANSMITTERS. Some states do not allow the exclusion or limitation of incidental or consequential damages or exclusions or limitations on the duration of implied warranties or conditions, so the above limitations or exclusions may not apply to you. This limited product warranty gives you specific legal rights, and you may also have other legal rights which vary from state to state.