



Reference Manual

The product, and product features as described in this document are subject to change without notice and does not represent a commitment on the part of IDENTEC Solutions, Inc. The software described in this document is furnished under a license agreement.

Limitation of Liability. In no event shall Identec or its suppliers be liable for any damages whatsoever, including damages for loss of business profits, business interruption, loss of business information or any other loss arising out of the use of or inability to use this product, or the provision or failure to provide support services. IDENTEC's entire liability shall be limited to the replacement cost of this product.

NOTE: This equipment has been tested and found to comply with the limits for a Class A digital device, pursuant to Part 15 of the FCC Rules. These limits are designed to provide reasonable protection against harmful interference when the equipment is operated in a commercial environment. This equipment generates, uses, and can radiate radio frequency energy and, if not installed and used in accordance with the instruction manual, may cause harmful interference to radio communication. Operation of this equipment in a residential area is likely to cause harmful interference in which case the user will be required to correct the interference at his own expense.

Warning: Changes or modifications to this unit not expressly approved by the party responsible for compliance could void the user's authority to operate the equipment.

FCC ID: OO3-ILR-IPORT
CANADA: 35381032062A
MODEL: i-PORT
TYPE: II/S

This Class A digital apparatus meets all requirements of the Canadian Interference-Causing Equipment Regulations.

Cet appareil numérique de la classe A respecte toutes les exigences du Règlement sur le matériel brouilleur du Canada.

Contents

<u>CONTENTS</u>	3
<u>1 INTRODUCTION</u>	5
<u>1.1 GENERAL</u>	5
<u>1.2 PRODUCT DESCRIPTION</u>	5
<u>2 I-PORT TERMINAL BLOCKS — BRIEF DESCRIPTION</u>	6
<u>3 SYSTEM INPUTS AND OUTPUTS</u>	8
<u>3.1 OPTO COUPLED INPUTS (INPUT 1...4)</u>	9
<u>3.2 OPTO COUPLED USER OUTPUTS (RLY 1A, 1B...4A, 4B)</u>	9
<u>3.3 TEST SERIAL PORT</u>	9
<u>3.3.1 RS232 9 Pin Interface Connection for Test Serial Port</u>	9
<u>3.4 BAR CODE INTERFACE</u>	9
<u>3.4.1 RS232 9 Pin Interface Connection for Bar Code</u>	9
<u>3.4.2 RS485 9 Pin Interface Connection</u>	10
<u>3.5 ANTENNA MULTIPLEXER OUTPUTS</u>	10
<u>4 SMA COAX CONNECTORS (SOCKETS)</u>	10
<u>5 SELECTOR SLIDE SWITCHES</u>	11
<u>6 I-PORT PC CARDS</u>	11
<u>6.1 THE ILR-CARD</u>	12
<u>6.2 THE I-FLASH MEMORY CARD</u>	13
<u>6.3 THE ATA FLASH STORAGE CARD</u>	13
<u>6.4 USER INTERFACE CARD</u>	13
<u>6.4.1 Ethernet Card</u>	13
<u>6.4.2 Modem PC Card (optional)</u>	14
<u>6.4.3 RF Modem Card (optional)</u>	14
<u>7 I-PORT ANNUNCIATOR LEDES</u>	14
<u>8 RESET BUTTON</u>	17
<u>9 EXTERNAL POWER SUPPLY REQUIREMENTS</u>	17
<u>9.1.1 The Power Supply Basic Requirements</u>	17
<u>9.1.2 Backup Battery</u>	18
<u>10 LCD OPTION</u>	18
<u>11 INSTALLATION AND WIRING PROCEDURE</u>	18
<u>11.1 PHYSICAL INSTALLATION</u>	19
<u>11.2 ELECTRICAL INSTALLATION</u>	19
<u>11.3 INITIAL POWER UP</u>	20
<u>11.4 CONFIGURATION OF THE I-PORT FOR LANS</u>	20

<u>12</u>	<u>I-PORT ANTENNAS</u>	21
<u>13</u>	<u>I-O TAGS</u>	23
<u>14</u>	<u>SOFTWARE</u>	24
<u>15</u>	<u>ILR EXPLORER DEMONSTRATION/TESTING SOFTWARE</u>	25
<u>16</u>	<u>PRODUCT SUPPORT</u>	25
<u>16.1</u>	<u>TO REACH IDENTEC SUPPORT</u>	26
<u>16.1.1</u>	<u>Online support</u>	26
<u>16.1.2</u>	<u>E-mail support</u>	26
<u>16.1.3</u>	<u>Telephone and Fax Support</u>	26
<u>16.1.4</u>	<u>Support numbers</u>	26
<u>16.1.5</u>	<u>Order Desk</u>	26
<u>16.1.6</u>	<u>Warranty Service</u>	26
<u>16.1.7</u>	<u>Additional Tools and Training</u>	26
<u>17</u>	<u>APPENDIX</u>	27
<u>17.1</u>	<u>I-PORT PRINTED CIRCUIT BOARDS</u>	27
<u>17.1.1</u>	<u>The Power Supply Board</u>	27
<u>17.1.2</u>	<u>The Computer Board</u>	27
<u>17.1.3</u>	<u>The LED Board</u>	27

1 Introduction

1.1 General

This document provides information for the installation and operation of the IDENTEC i-PORT fixed RFID interrogator.

Other documentation that may be applicable includes the *Application Developers Guide To Programming For The ILR Library*, the *i-COM User Manual*, the *ILR-CARD Installation & Configuration Sheet*, and the *i-Q Tag Technical Sheet*.

1.2 Product Description

The i-PORT is a 100 MHz computer with an installed ILR Card for communicating with the i-Q series of active tags. The i-PORT is configured to provide application developers with the necessary connections and controls for advanced automatic data capture applications using ILR technology.

The operating system in the i-PORT is Windows CE[®] that provides data management and provides the interface to the ILR-CARD and other user optional PC Cards in the i-PORT. Application programs developed to run on the i-PORT are written using high-level application languages. Programs use calls to the IDENTEC i-PORT software library to access the RF functions and other controls on the i-PORT. For additional information on programming the i-PORT please refer to the document; *Application Developers Guide To Programming For The ILR Library*.

The i-PORT enclosure is an IP65 (or is it P66 / NEMA 4 (CSA/UL/VDE)) rated steel case with a glass panel for viewing the status LEDs. An optional LCD is also available for the i-PORT that replaces the glass panel with a 480 X 320 backlit monochrome touch screen to allow data input and application commands to be entered directly at the i-PORT.

Cable entry for wiring the i-PORT is through five compression seal cable clamps at the base of the enclosure. The access door to the i-PORT is equipped with a gasket seal and is closed and opened using a special tool that is included.

i-PORT Block Diagram

2 i-PORT Terminal Blocks — Brief Description

The i-PORT terminal block lay out is depicted in figure 2. The function of each of the connectors is described below.

Caution: Never connect or

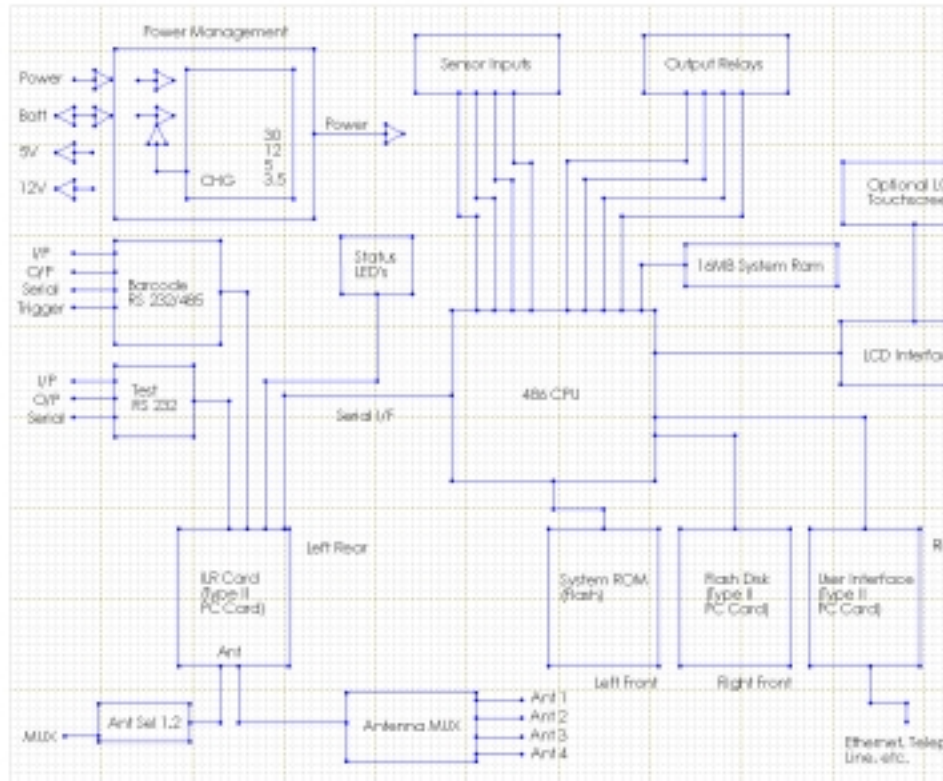

Figure 1

disconnect any cable or remove or install a PC Card while the i-PORT is running.

Two terminals

8 – 20V AC

Input power supply for i-PORT, to be used when only an AC power source is available. Range min. 8V to max.20V AC. Recommended range is 12V to 18V AC.

Two terminals pos. & neg.

8 – 30V DC

Input power supply for i-PORT, to be used when only a DC power source is available. Range min. 8V to max. 30V DC. Recommended range is 12V to 24V DC.

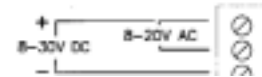

Note: Either DC or AC power can be applied, but never both at the same time. Obey terminal polarity for any DC source. Caution must be taken to insure only the first and third block connectors are used for DC and only the first and second block connectors are used for AC.

6V BAT+

Positive terminal of 6V backup battery.



6V BAT- Negative terminal of 6V backup battery. This terminal is connected to system ground

Note: The battery voltage must be 6V. The battery should be either a Sealed Lead Acid or a Gel Cell. The recommended minimum capacity for the battery is 2.6 Ah. This is sufficient to provide back up power for short power outages lasting a few minutes.

Total of 12
GND terminals

GND System ground.

Terminal pair

RLY 1a, 1b User relay contacts enabled by software.

Note: Contact rating for these solid-state relays is max. current 130mA, max. load voltage 300V_{rms}, max. power dissipation 500mW. The tighter of any restrictions applies. Typical ON-resistance is 25 static, 12 at full load. These ratings apply to all relay contacts.

Terminal pair

RLY 2a, 2b User relay contacts enabled by software.

Terminal pair

RLY 3a, 3b User relay contacts enabled by software.

Terminal pair

RLY 4a, 4b User relay contacts enabled by software.

Total of 4
terminals

INPUT 1, 2, 3, 4 Opto-coupled user definable trigger inputs, pull to ground to activate (short to GND terminal).



BARCODE TRIGGER Enables signal input from Barcode Reading Device via the serial connection. Pull to ground potential to activate (short to GND terminal).

BARCODE TX Serial output to Barcode Reading Device.

BARCODE RX Serial input to Barcode Reading Device.



Note: Depending on top slide switch setting, the serial line for the barcode ports will be compliant to either RS-232 or RS-485 standard. These terminals can be used to connect other serial devices.

TEST TX Serial test output.

TEST RX Serial test input.

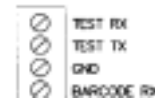

Note: The serial line for the test connection is always RS-232.

Two terminals, plus GND	ANT SEL 1, 2	Software controlled output of two antenna selector control signals for external antenna multiplexer with maximum four antenna ports.	
Two terminals,	12V	Auxiliary power outputs, for user selected devices. Maximum combined load for the two 12 V terminals is 250mA.	
Two terminals,	5V	Auxiliary power outputs, for user selected devices. Maximum combined load for the two 5 V terminals is 250mA.	

Note: The auxiliary power outputs are always on and are not software controllable.

i-PORT Terminal Block Layout

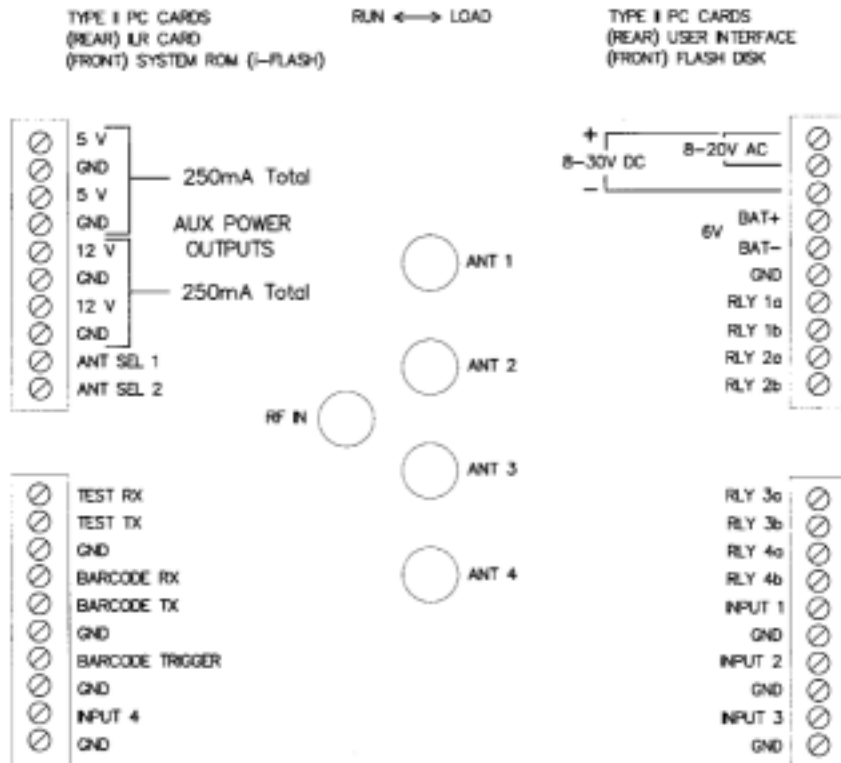

Figure 2

3 System Inputs and Outputs

This chapter describes in greater detail the inputs and outputs connections on the i-PORT terminal blocks.

3.1 Opto Coupled Inputs (INPUT 1...4)

The opto-coupled inputs are tied to 5V via the internal opto-isolator, a limiting resistor and an input status LED. Left open, no current flows and the status LED is off. If the input is tied to ground, directly through dry relay contacts, or via a resistor of up to 100 ohms, the LED will light and the ILR CARD will see the input as 'pulled low'. Resistance of greater than 100 ohms may cause the LED to glow but may be insufficient for the input to be seen as 'pulled low'.

3.2 Opto Coupled User Outputs (RLY 1a, 1b...4a, 4b)

The four relay outputs are opto-isolated solid state relays offering 5,000V isolation with a current rating of 130mA at 350V. The contacts are normally open, indicated by the corresponding status LED being unlit. The status LED lights when the relay contacts 'close'. Both contacts are electrically isolated from other system voltages and float.

3.3 Test Serial Port

The test serial port is set to 9600 baud and is a 3 wire port (TX, RX and GND). It offers 15KV isolation and is true RS232. Data to and from this port are relayed by the ILR CARD to the host computer.

3.3.1 RS232 9 Pin Interface Connection for Test Serial Port

<i>Signal Name</i>	<i>Pin</i>
TEST TX	2
TEST RX	3
GND	5

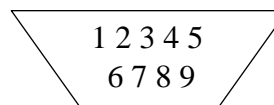

3.4 Bar Code Interface

The Bar Code serial port is set to 9600 baud and is a 4 wire port (TX, RX, Trigger and GND). It offers 15KV isolation and is true RS232. Data to and from this port are relayed to the host computer by the ILR CARD. This connection is intended for a tethered bar code scanner with the power provided by one of the 5V auxiliary outputs.

This input can be switched from RS232 to RS485 if long communication range is needed. This connection can be used to connect any serial input device. The slide switch for RS232 or RS485 is at the top of the i-PORT, and is described in section 5 *Selector Slide Switches*.

3.4.1 RS232 9 Pin Interface Connection for Bar Code

<i>Signal Name</i>	<i>Pin</i>
BAR CODE TX	2
BAR CODE RX	3
GND	5
BAR CODE TRIGGER	6

3.4.2 RS485 9 Pin Interface Connection

<i>Signal Name</i>	<i>Pin</i>	<i>Function</i>
BAR CODE TX	2	Data A
BAR CODE RX	3	Data B
GND	5	
BAR CODE TRIGGER	6	

3.5 Antenna Multiplexer Outputs

These are the ANT SEL 1 and ANT SEL 2 signals and are intended for connecting an external antenna multiplexer. The external multiplexer requires only a single coax cable to run from the MMCX antenna connection on the ILR-CARD to the multiplexer. In installations where the i-PORT cannot be installed in close proximity to the antenna locations the use of an external multiplexer can reduce the coax wiring requirements.

Note: The total length of coax cabling used to connect an antenna can affect signal strength from the antenna to the i-PORT. A signal loss more than 6 dB will reduce read range.

The Antenna Multiplexer Outputs are software controlled digital outputs, in binary form offering one of four combinations with the two signals. These are ESD protected, and can drive up to 4mA, within the voltage range of 0 to 3.3V. They should not be connected to circuits that may pull the outputs to voltages higher than 3.3V.

4 SMA Coax Connectors (Sockets)

The RF antenna connector on the ILR CARD is a miniature MMCX connector. This connects to the SMA input connector on the antenna multiplexer using the 3.5 inch coax pigtail. The output SMA connectors on the multiplexer connect up to four antennas to the i-PORT. The ANT 1 to ANT 4 status LEDs indicate the active antenna. The illuminated LED will change as the multiplexer sequences through the antennas, with the LED for the last antenna sequenced remaining illuminated.

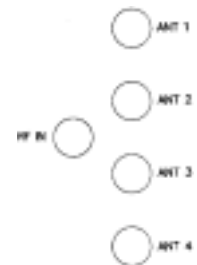

RF IN	Takes a 3.5 inch coax pigtail (part # CAB001) to connect the 'RF IN' port to the ILR-Card RF connector
ANT 1, 2, 3, 4	Independent antenna ports for one to four external antennas

Note: The address sequencing for the antenna multiplexer is software controlled.

5 Selector Slide Switches

There are two selector slide switches on the i-PORT. One slide switch is located on the topside of the LED board, and is used to switch the bar code connection between RS 232 and RS 485. This switch setting must comply with the serial interface of the connected device.

The other slide switch is located between the PC Card slots. The setting options for this switch are RUN and LOAD. This switch must be set to RUN during operation of the i-PORT. The LOAD position is used to transfer a compressed binary image file from a Master Image PC Card to the i-Flash Memory Card. This procedure should only be done by IDENTEC certified advanced programmers.

6 i-PORT PC Cards

The i-PORT has four PC Card slots on the computer board. The slots are for the ILR-Card, the i-Flash Memory Card, the ATA Flash Storage Card, and the User Interface Card.

Note: Each of the four PC Cards described below has its own designated PCMCIA slot on the Computer Board and is not interchangeable with the others. Before removing or replacing any of the PC Cards the power to the i-PORT must be turned off.

Note: All PC Cards used in the i-PORT must be 5 volt.

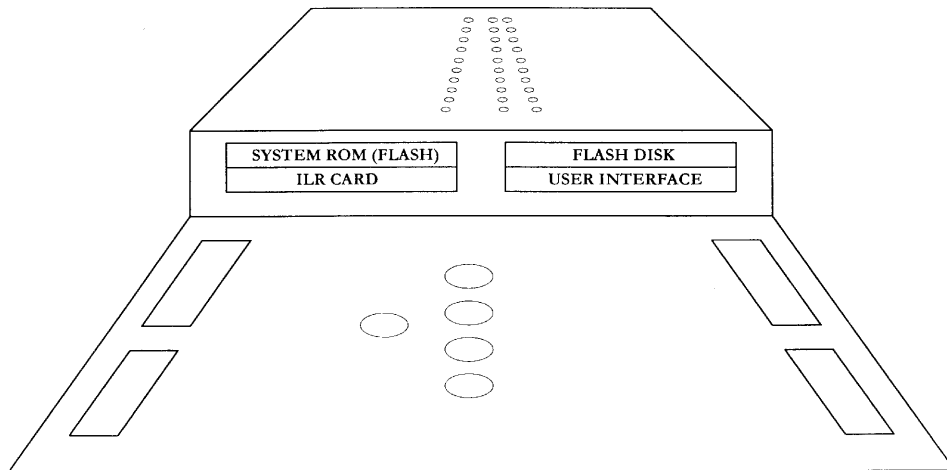

6.1 The ILR-Card

The ILR-CARD is the rear PC Card on the left side. It has two I/O connectors on the exposed end, the MMCX Antenna connector, and a 15-pin programming connector. The programming connector is used by IDENTEC to configure the ILR-CARD. There are also three LEDs on the exposed end of the ILR-CARD to indicate transmit, receive and RF carrier detect.

The ILR-CARD contains a Configurable Processor System Unit (CPSU) with internal non-volatile memory. The CPSU chip is programmed by IDENTEC and contains the firmware code to run the i-PORT. The CPSU also contains a Real Time Clock, with a separate power supply that will power the clock for over 24 hours.

The ILR-CARD contains the RF circuitry for the wireless communication with IDENTEC tags. The application software running on the i-PORT, or other host computer, sends commands to the CPSU to communicate with the tags. The CPSU on the ILR-CARD controls the function of all LED's on the LED Board, as well as the Piezo buzzer on the Power Supply Board. It also manages the 6V backup battery charge function. The normal mode (power-up and standby) of the ILR-CARD is 'Receive Mode', as opposed to the time-limited 'Transmit Mode', which has to be initiated by the controlling host computer.

Note: The ILR-CARD used in the i-PORT is in a PC Card Type II housing but it is not configured with a PCMCIA interface. The ILR-CARD in the i-PORT has a serial interface and can only be used in the assigned card slot on the i-PORT. Each ILR-CARD is marked with an

interface type, either PCMCIA or serial. Do not use an ILR-CARD with a PCMCIA interface in the i-PORT.

6.2 The i-Flash Memory Card

This card is a linear Flash memory device with special non-volatile memory. The standard card supplied with the i-PORT is 4MB, but optional upgrades are available for 8MB and 16MB of memory. The i-Flash Card contains compressed binary image files used by the operating system running on the Computer Board.

Note: The i-Flash Card is a custom linear memory card and cannot be replaced by commercial ATA Flash Storage Cards.

6.3 The ATA Flash Storage Card

The i-PORT file system uses a Type II PC Card format ATA flash storage card. The standard card provided with the i-PORT is 8MB, but larger cards of 16MB or 32MB are supported. The ATA flash storage card carries files for the operating system, among them the previously programmed IP Address. If replacing this card an IP Address has to be programmed in to the new card before the i-PORT can connect to a network.

Note: The i-Flash card is programmed with a default IP Address. If the ATA Flash Storage Card is replaced without programming in the new address the default will be used, (see section 10 Installation and Wiring Procedures for IP Address programming instructions).

6.4 User Interface Card

The rear right PC Card socket on the i-PORT is for the user interface card. This can be any Type II PC Card with a Windows CE[®] driver.

Note: To remove the PC Cards in the i-PORT the terminal blocks must first be removed. Disconnect the power, or remove the power connection terminal block first.

6.4.1 Ethernet Card

This Type II PC Card is the standard card provided with an i-PORT for the user interface. A standard network adapter plugs into this 10BaseT LAN card to link it to an industry standard, RJ-45 CAT 5 twisted-pair network cable connector.

6.4.2 Modem PC Card (optional)

For dial-up networking a modem card can be inserted in the User Interface PC Card slot on the i-PORT. This card would be used instead of the Ethernet Card

6.4.3 RF Modem Card (optional)

For wireless networking a RF modem can be used with the i-PORT. An IEEE 802.11 (Frequency Hopping?) card is recommended. If using an RF modem it is necessary to use an external antenna because of the i-PORT metal enclosure.

Note: to maintain the IP65 industrial rating all cabling must be through the five compression cable clamps at the bottom of the i-PORT. Not all connector types will pass through these clamps. It may be necessary to terminate cabling after it is pulled into the i-PORT housing.

7 i-PORT Annunciator LEDs

The annunciator LEDs are for testing, and to monitor i-PORT functions. For a layout see figure 3.

i-PORT Annunciator LED Board

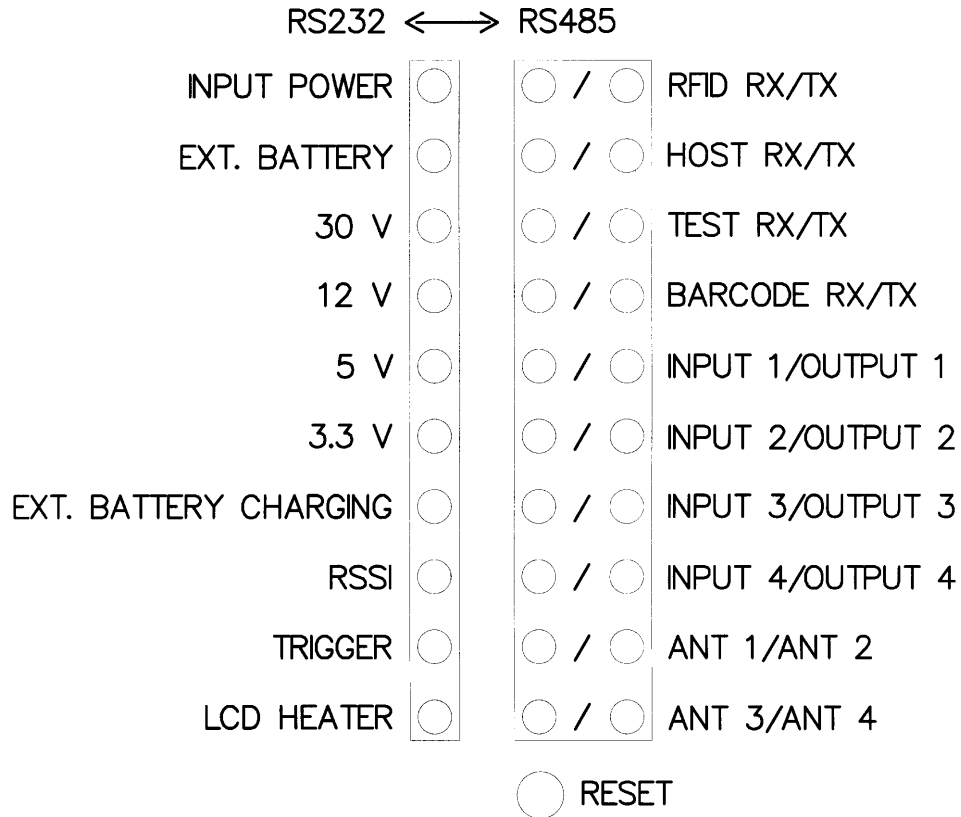

Figure 3

The left side single row of LEDs in figure 3 are described below.

INPUT POWER Indicates the presence of external supply power for the i-PORT.

EXT. BATTERY If the external power supply fails, and the 6V backup battery takes over this LED will be lit. Only one of the power source indicator LEDs, the INPUT POWER or the EXT. BATTERY, will be lit at any time.

30V Internal 30V supply present.

12V Internal 12V supply present.

5V Internal 5V supply present.

3.3V Internal 3.3V supply present.

Note: The internal voltage LEDs will all be illuminated when input power is applied. There are no LEDs for the auxiliary power outputs.

EXT. BATTERY CHARGING Indicates the 6V backup battery is being charged.

RSSI Receive Signal Strength Indicator (currently not used).

TRIGGER Displays activity on the BARCODE TRIGGER input.

LCD HEATER Displays heater element on (when equipped).

The right side Annunciator LEDs are organized and labeled in pairs. For the label “RFID RX / TX”, the RX is the left LED and the TX is the right LED.

RFID RX Lights whenever the ILR-CARD receives valid RFID data from tags.

RFID TX Lights whenever the ILR-CARD transmits RFID data to tags.

HOST RX Lights when i-PORT receives data or commands from controlling host computer (i.e. via LAN connection).

HOST TX Lights when i-PORT transmits data to controlling host computer.

TEST RX Shows activity on serial transmit line (RS-232) for testing.

TEST TX Shows activity on serial receive line (RS-232) for testing.

BARCODE RX Indicates the input of data from a barcode reader or other serial input device over the serial terminal (RS-232 or RS-485).

BARCODE TX Indicates the output of commands to a barcode reader or other serial device over the serial terminal (RS-232 or RS-485).

INPUT 1 Lights when terminal INPUT 1 is active (shorted to ground).

INPUT 2 Lights when terminal INPUT 2 is active (shorted to ground).

INPUT 3	Lights when terminal INPUT 3 is active (shorted to ground).
INPUT 4	Lights when terminal INPUT 4 is active (shorted to ground).
OUTPUT 1	Lights when user relay contacts RLY 1a, 1b are closed.
OUTPUT 2	Lights when user relay contacts RLY 2a, 2b are closed.
OUTPUT 3	Lights when user relay contacts RLY 3a, 3b are closed.
OUTPUT 4	Lights when user relay contacts RLY 4a, 4b are closed.
ANT 1, 2, 3, 4	Displays selector status of antenna multiplexer.

8 Reset Button

Located at the bottom of the annunciator LED panel is the system master reset button. Depressing this button will cause a warm reboot that will restart Windows CE ® and reset the ILR card without interrupting the power supply.

9 External Power Supply Requirements

Operation of the i-PORT requires an AC or DC power supply. IDENTEC strongly recommends the use of a linear (transformer) power supply with or without built-in rectifier. Suitable industrial transformers are widely available, or can be ordered from IDENTEC.

The use of a switching power supply is not recommended because it may not be able to provide a sufficient initial inrush current for power up. The i-PORT consumes about 6 watts under normal use, consumption increases by 5 watts for the optional LCD heater and by another 3 to 5 watts when charging the backup battery.

9.1.1 The Power Supply Basic Requirements

For a DC power supply the output voltage must be between 8V and 30V DC. The recommended power range is 12V to 24V DC. Output power rating should be no less than 12W DC.

For an AC power supply the output voltage must be between 8V and 20V AC. The recommended power range is 12V to 18V AC. Output power rating should be no less than 14VA AC.

The suitability of the power supply output can also be determined with an output current rating of 1A minimum at 12V, or a current rating of 1.5A minimum below 12V.

Example:

The output current of the transformer must be capable of no less than 1000mA for a 12V AC/DC linear supply.

9.1.2 Backup Battery

A 6V backup battery, usually a lead acid gel cell, can be connected directly to the backup battery terminals. An inline, slow-acting fuse of 3 Amps rating is highly recommended. The battery is charged at 180mA until fully charged and then will continue to be trickle charged. The battery supplies power to the i-PORT when the input power drops below the battery terminal voltage.

10 LCD Option

The LCD is a factory-installed touch screen to allow data input and systems functions to be controlled directly at the i-PORT. The LCD replaces the clear glass panel on the front of the i-PORT and is connected to the computer board with a flex cable. The LCD screen provides the following features:

- 480 X 320 VGA resolution
- Monochrome, 4 shades of gray
- Permanent electro luminescent backlight
- Auto temperature sensing heater to extend useful range
- Auto temperature compensating contrast
- Protective film overlays available

11 Installation and Wiring Procedure

This chapter describes the installation and wiring procedure for an i-PORT in a fixed location. If installing the i-PORT on mobile equipment, such as a forklift, see the IDENTEC bulletin *Using the i-PORT as a Mobile Interrogator*.

Environment Range	
<i>Physical</i>	
Dimensions	11.75" x 7.75" x 3.2" (30 x 20 x 8 cm)
Weight	7.5 lbs (3.4 kg)
<i>Operational</i>	
Temperature	32° F to 158° F (0° C to 70° C)
Humidity	90% non-condensing
<i>Storage</i>	
Temperature	-40° F to 185° F (-40° C to 85° C)
Humidity	90% non-condensing



Important Note to Installer:

This device requires professional installation by a certified electronics technician or electrical engineer, following each and all procedures of the installation manual. This device is only legal to operate in conjunction with the antenna type approved by FCC and Industry Canada.

The installer is taking legal responsibility that all steps outlined in the IDENTEC installation manual have been executed properly, and that the installed device is complying with FCC Part 15 and the limits for a ‘Class A Digital Device’, as defined by Industry Canada.

11.1 Physical Installation

The rugged i-PORT enamel steel enclosure is intended to be wall-mounted with four adequately sized screws. Before mounting the i-PORT to the wall the four plastic caps need to be removed from the rear of the enclosure.

The i-PORT enclosure is rated IP65 (P66?) for protection against water spray. The enclosure is suitable for industrial installation, but is not intended to be use in an exterior location. If it is necessary to install the i-PORT in an exterior location it must have additional shielding against the weather.

The operational temperature range for the i-PORT is between 32° F and 70° F. If the temperature could vary out of this range additional precaution must be taken. In the case of cold temperatures a heat element can be installed in the i-PORT.

11.2 Electrical Installation

Wherever available, a ground wire (Protection Earth) should be connected to the internal case grounding-stud. This is a recommendation only and is not essential for i-PORT functionality. The i-PORT is a low voltage device with no line voltage required.

For a description of the electrical connections refer to Section 2 *i-PORT Terminal Blocks — Brief Description*, and Section 3 *System Inputs and Outputs*. For the specifications on the power supply see Section 8 *External Power Supply Requirements*.

The four terminal blocks in the i-PORT can be removed to make connecting wires easier. If there is no inline power switch being used with the i-PORT the power connection block should be inserted last for power up. This must be done after all other connections have been made and the other terminal blocks properly installed.

Note: All 'GND' terminals are directly connected to system ground, so is the negative battery terminal 'BAT-'.

Generally, any type of cable can be used that fits through the five compression clamps. From a practical consideration, the wire gauge for control signal inputs and outputs should be AWG 18 or 20. Power wires and ground should be AWG 18.

Note: The Ethernet CAT 5 cable will have to be terminated with an RJ-45 connector after feeding it through one of the five compression clamps.

Note: The Ethernet cable needs to run through the Ferrite Box Snap to suppress RF noise from the Ethernet Card. The cable should be wrapped around the Ferrite Box so the cable passes through the box twice. The installed Ferrite box should be attached to the Ethernet cable inside the i-PORT, and placed in the bottom left corner of the enclosure.

11.3 Initial Power Up

When the i-PORT is first installed connect the input power source for at least one minute then reset the i-PORT or cycle power and commence normal operation. This ensures adequate charge up time for the internal Real Time Clock supply voltage. This procedure has to be repeated whenever the i-PORT had been disconnected from its input power source for more than 24 hours.

11.4 Configuration of the i-PORT for LANs

When using the i-PORT as a client on an Ethernet network the start-up IP address will be the default address stored on the ATA Flash Storage Card. To change the address this card can be removed from the i-PORT and inserted into a computer with a PC Card slot. The card can then be accessed as a drive on the computer.

Note: for information on accessing a PC Card as a drive on the computer refer to your Windows® user documentation.

With the Flash Storage Card in a Windows® computer use a text editor to open the file “ipsettings”. This data file is ASCII format. The values in this file must be listed as follows:

IPAddress
Subnetmask
DefaultGateway
Blank Line

Before saving make sure you hit enter after DefaultGateway.

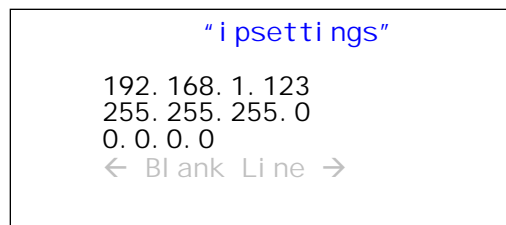

```
"ipsettings"
192. 168. 1. 123
255. 255. 255. 0
0. 0. 0. 0
← Blank Line →
```

Figure 4

Every time the i-PORT is started the RestoreReg file will be loaded. This program reads applicable keys from the i-PORT registry and compares the existing default key values with the values stored in the “ipsettings” file. Any changes made in the “ipsettings” file will be used by the system. These changes are stored in the i-PORT RAM and are updated from the “ipsettings” file anytime the i-PORT is rebooted. If a new ATA Flash Storage Card is used in the i-PORT the “ipsettings” file must be updated.

12 i-PORT Antennas

Antennas for use with the i-PORT are required to have a gain equal to or less than 5dBic. It is recommended that the antenna polarization should be elliptical or circular, although in applications where the orientation of the tag is in a consistent and known position linearly polarized antennas can also be used.

The i-A9185 antenna typically supplied with the i-PORT is an elliptically polarized patch type antenna, providing a superior radiation pattern for interior or exterior use.



Figure 5

The i-PORT can connect up to four antennas using either the internal multiplexer or an external multiplexer. The cable to connect the ILR-CARD to the internal multiplexer is supplied with the i-PORT. To connect an external multiplexer the coax cable to the ILR-CARD can use a SMA connector with the supplied antenna pigtail as a connector converter, or the coax will require an MMCX male end to connect directly to the ILR-CARD.

For any antenna connection the maximum cable length allowed can produce a decibel loss no greater than 6dB. Each coax cable type and gauge will have different loss characteristics and the installer should contact the cable supplier to determine the suitability any cable for their application.

In most locations it is probable that null spots will exist in the coverage of any single antenna. If a tag is in a null spot even though it is within range of an antenna it will not be interrogated. This is typically not a problem when tags are moving through a read zone, but if the tags must be interrogated while stationary it will be necessary to create redundancy in the read zone. Any stationary tag that must be interrogated should be within range of at least two antennas.

13 i-Q Tags

IDENTEC i-Q tags are available in a number of configurations to match the tag with the application. Tags of different types can be mixed in a single system and can be interrogated simultaneously by an i-PORT. Tags are available as read only, read/write with 8 KB of memory, and a read/write tag with and optional temperature monitor. Tag memory is expandable to 32KB.

Table 1

FEATURES	i - QR	i - Q8	i - Q8T
READ RANGE > THAN 100 FEET	YES	YES	YES
8 KBYTES OF MEMORY		YES	YES
BROADCAST CAPABILITY	YES	YES	YES
ANTI-COLLISION ALGORITHM	YES	YES	YES
5 YEAR BATTERY LIFE	YES	YES	YES
TEMPERATURE MONITORING			YES
OPERATES IN HARSH ENVIRONMENTS	YES	YES	YES

All i-Q tags are active and include an RF transmitter, RF receiver, and a microprocessor. The communication range between a tag and an i-A9185 antenna connected to an i-PORT interrogator will be up to 30 meters under typical conditions. Read range will vary depending on the local conditions, and it is important to test tag read performance under a variety of probable scenarios.

For more information see the *i-Q Tag Technical Sheet*.

14 Software

This chapter provides basic information on how to control the operation of the i-PORT. For more detailed information please see the *Application Developers Guide To Programming For The ILR Library*.

ILR technology requires an application program to provide end-user functions, this level of software is provided by the System Integrator. To facilitate the development of user specific applications, IDENTEC has extended the Windows API (Application Program Interface) to include easy access to ILR functions using C program calls.

IDENTEC does provide a demonstration package to allow the installer to configure and to test the basic functions of the i-PORT. This software is covered in Section 14 *ILR Explorer Demonstration/Testing Software*.

To allow maximum flexibility in interrogating tags, scanning barcodes, allowing user data entry, providing user information, formatting and sorting data, and data transfer to tags and over a network, the i-PORT functions under the direction of a control program. This control program customizes the i-PORT to do the required task. It is generated by a menu-driven Windows application that allows the user to specify how the system will operate.

This is a simple but very powerful feature of the IDENTEC ILR system. It allows an i-PORT to perform similar tasks in very different ways from completely automated tag interrogation and reporting to automated assistance in process operations. The data source for various fields can be specified, e.g. tag ID, tag file, barcode scan, user-keyed input, or a digital input. A sequence of events can be specified to gather data, format data in a specific way, and/or communicate data to a specific location.

File I/O system on the i-PORT has the usual features such as Create, Delete, Read, Write, Directory, and Attributes. The tag file system supports any data format that will fit in the space available. Flat files are supported with fields delimited by column or delimiter character, and records delimited by linefeed.

Note: Microsoft® Windows® CE Toolkit for Visual C++ is required to make applications run on Windows® CE operating system for x86 microprocessors that is used on the i-PORT.

15 ILR Explorer Demonstration/Testing Software

ILR Explorer runs on a host Computer to demonstrate and test the capabilities of an i-PORT. The system requirements are a 486 or higher CPU, running Windows 95 or newer, with a minimum of 120MB of hard drive space.

The i-PORT is equipped with an Ethernet card for connection to a LAN, or it can be connected directly to an Ethernet equipped computer by using a mirrored Cat. 5 cable. The Ethernet card included with the i-PORT is a 10BaseT connection.

ILR Explorer allows the user to communicate with all i-Q type tags within range of the antenna, write and read data files to and from tags, set various properties of the i-PORT and tags, read temperature log information from a tag and create files to be stored on the tag.

15.1.1.1 Installing ILR Explorer

On the installation disk included is an Install Shield setup file. Please run the file "setup.exe" to start the installation process.

15.1.1.2 Running ILR Explorer

To start ILR Explorer double click the icon on your desktop, or in the folder you selected during installation, or select "ILR Explorer" from the "Start" Menu.

For more information on the ILR Explorer see the "README.TXT" file included on the ILR Explorer disk.

16 Product Support

Technical support for IDENTEC ILR products is available by e-mail, online and by telephone or fax. Full support is provided to Authorized Systems Integrators who have completed the technical training sessions and are certified ILR technicians.

Additional training and product support is available from IDENTEC under a support agreement. Field Support is also available on a contract basis. Support can be provided for site surveys, and for product installation and testing. Contact your account manager for full details.

16.1 To Reach IDENTEC Support

16.1.1 Online support

Technical support is available online to all IDENTEC Authorized System Integrators. Answers to many common questions and problems are included in our searchable database at www.IDENTEC.com/faq.htm this database can be made accessible to any product user.

16.1.2 E-mail support

When sending an e-mail include your name, company, telephone and fax numbers along with your question or problem.

In North America support@IDENTEC.com

In Europe and the UK support@IDENTEC.au

16.1.3 Telephone and Fax Support

Telephone assistance in North America is available from 8:30 to 5:30 Pacific time, Monday through Friday, Canadian holidays not included. .

16.1.4 Support numbers

North America

Tel: (250) 860-6567

Fax: (250) 860-6541

Toll Free Phone 1-877-IDENTEC

16.1.5 Order Desk

To order products contact the order desk by phone or fax

North America

Tel: (250) 860-6567

Fax: (250) 860-6541

Toll Free Phone 1-877-IDENTEC

16.1.6 Warranty Service

For warranty service contact the warranty department within your region to get a warranty claim number. All products returned for warrantee service must include a warranty service number for prompt processing.

In North America phone (250) 860-6567

16.1.7 Additional Tools and Training

Support is provided only to trained systems integrators. IDENTEC provides training in ILR technology with the purchase of a development kit. To have additional employees or third party consultants certified to receive full access to product support IDENTEC offers certification training.

17 Appendix

17.1 i-PORT Printed Circuit Boards

The i-PORT consists of three PCBs, the Power Supply Board, the Computer Board, and the LED Board.

17.1.1 The Power Supply Board

This circuit board incorporates the following functional groups and components:

Bridge Rectifier for AC Input Power

Self-resetting Fuse

30V Switching Power Supply (internal)

12V Switching Power Supply (internal & auxiliary user access)

5V Switching Power Supply (internal & auxiliary user access)

3.3V Switching Power Supply (internal)

6V Battery Charger Switching Power Supply (external)

Real Time Clock Backup Voltage Supply (internal)

Quadruple Antenna Multiplexer, software controlled

CPU Reset Circuit, monitoring 3.3V and RESET pushbutton

Selector Slide Switch for Serial Bus Standard, RS-232 or RS-485

Serial Driver Chips for RS-232 and RS-485

Opto isolators and Over voltage Protection for all Inputs & Outputs

4 User definable Solid State Relays, SPST

Piezo Buzzer, software controlled

17.1.2 The Computer Board

This circuit board incorporates the following functional groups and components:

Main CPU, Type 486; running OS Windows CE®

Onboard DRAM

Four PCMCIA slots for PC Cards Type II (see also 'PC Cards Description')

Diagnostic Connector

LCD Line Drivers and Connectors (LCD Panel with Touch-Screen is optional)

17.1.3 The LED Board

This circuit board incorporates the following components:

System Master Reset Pushbutton

30 LED's to indicate the operational status of the i-PORT (see LED description)