

LO

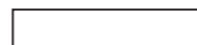

ENGLISH

First assemble the bed frame/s. The assembly instruction is supplied with the bed frame/s. When the assembly is completed, there will be fittings and furniture components left. The number of surplus parts is depending on which model you have chosen to assemble. **IMPORTANT! Do not hang things on the bed which the child can get stuck in when playing, e.g. loops of rope, belts etc.** Keep the instruction for future use.

DEUTSCH

Zuerst den/die Bettrahmen nach der beige-packten Anleitung montieren. Einige Beschläge und Möbelteile bleiben nach der Montage übrig (wie viele es sind, ist vom montierten Modell abhängig).

ACHTUNG! Keine Gegenstände am Bett hängen lassen (z.B. Seilschlingen, Gürtel etc.). Kinder könnten sich beim Spielen darin verfangen. Bitte diese Anleitung sorgfältig aufbewahren.

FRANÇAIS

Commencer par assembler le(s) cadre(s) de lit. Les instructions de montage sont fournies avec le(s) cadre(s) de lit. Il vous restera des pièces après le montage. Cela est normal et le nombre de pièces superflues dépend du modèle que vous avez choisi de réaliser. **Attention! Ne pas fixer au lit des objets auxquels l'enfant peut s'accrocher en jouant, cordes, ceintures, etc.** A conserver pour toute consultation ultérieure.

NEDERLANDS

Begin met het monteren van het bedframe/de bedframes. De aanwijzingen zitten in de verpakking van het bedframe/de bedframes. Je houdt na het monteren beslag en meubeldelen over. Het aantal overgebleven delen is afhankelijk van het gekozen model. **BELANGRIJK! Hang geen dingen aan het bed waarin kinderen tijdens het spelen vastrikt kunnen raken, zoals uiteinden van koorden, riemen e.d.** Bewaar de montageaanwijzing voor toekomstig gebruik.

ITALIANO

Inizia a montare la struttura/le strutture del letto seguendo le istruzioni incluse. A montaggio ultimato, avvanzeranno degli elementi e degli accessori di montaggio. Il numero dei pezzi avanzati dipende dal modello che hai scelto di montare. **IMPORTANTE! Non appendere al letto oggetti nei quali il bambino può rimanere impigliato, per esempio corde, cinture, ecc.** Conserva le istruzioni per ulteriori consultazioni.

ESPAÑOL

Monta primero el/los marcos de la(s) cama(s). Las instrucciones se incluyen junto con los marcos. Una vez terminado el montaje, verás que te habrán sobrado componentes y herrajes. El número de piezas sobrantes depende del modelo que hayas elegido. **¡IMPORTANTE! Recuerda que no debes colgar cosas de la cama en las que el niño se pueda enganchar cuando juega, como lo pueden ser lazadas de cuerda, cinturones, etc.** Guarda estas instrucciones como referencia.

PORTUGUES

Em primeiro lugar monte a(s) estrutura(s) da(s) cama(s). As instruções de montagem são fornecidas com a(s) estrutura(s) da(s) cama(s). Uma vez completada a montagem, é possível que sobejem ferragens e peças de mobiliário. O número de partes sobresselentes depende do modelo escolhido para montar. **IMPOR-TANTE! Não pendure objectos da cama, p.e. cordas, cintos, etc.,** nos quais a criança possa ficar presa quando estiver a brincar. Guarde as instruções para futura referência.

SVENSKA

Börja med att montera sängramen/ sängramarna. Anvisningen ligger tillsammans med sängramen/ sängramarna. Det blir beslag och möbeldelar över när monteringen är klar. Antalet överblivna delar beror på vilken modell du valt att montera. **VIKTIGT! Tänk på att inte hänga saker på sängen som barn kan fastna i när de leker. T.ex. lappar av rep, bälten m.m.** Spara anvisningen för framtida bruk.

DANSK

Begynd med at montere sengerammen/ sengerammerne. Vejledningen ligger sammen med sengerammen/sengerammerne. Der er beslag og andre møbeldele tilbage når du er færdig med monteringen. Antallet af tiloversblevne dele er afhængig af hvilken model du har valgt at montere. **Husk! Sæt ikke ting på sengen som børn kan hænge fast i når de leger. F.eks. løkker af reb, bæltter m.m.** Gem monteringsanvisningen til fremtidig brug

NORSK

Begynn med å montere sengerammen(e). Anvisningen ligger sammen med sengerammen(e). Det blir beslag og møbeldeler til overs når monteringen er ferdig. Antall deler til overs avhenger av hvilken modell du har valgt å montere. **VIKTIG! Pass på å ikke henge ting på sengen som barn kan sette seg fast i når de leker. F eks tau, belter m m.** Gjem anvisningen for senere bruk.

SUOMI

Aloita sängyn kehyksen/kehysten asentamisesta. Ohjeet ovat samassa pakkauksessa kehyksen/kehysten kanssa. Kiinnikkeitä ja osia jää yli. Yli jäävien osien määrä riippuu siitä, minkä asennusvaihtoehdon valitset.

TÄRKEÄÄ! Muista, ettei sänkyyn saa ripustaa esineitä, joihin lapset voivat jäädä kiinni leikkiessään. Tällaisia ovat esimerkiksi köydet ja vyöt. Säilytä ohjeet tulevaa tarvetta varten.

POLSKI

Najpierw należy złożyć ramę/y łóżka. Instrukcja jest dostarczana w opakowaniu. Po zakończeniu montażu okaże się, że niektóre elementy nie zostały wykorzystane. Ilość dodatkowych elementów zależy od wyboru modelu. **UWAGA! Nie wolno wieszac na łóżku żadnych przedmiotów takich jak pętle z lin, paski itp., w które dzieci mogłyby się zaplątać podczas zabawy.** Zachowaj instrukcję na przyszłość.

ČESKY

Nejprve sestavte rám/y postele. Návod k montáži je součástí balení. Po smontování vám zůstanou některé části nábytku a kování. Počet přebytečných částí závisí na tom, jaký typ postele jste se rozhodli sestavit. **DŮLEŽITÉ! Na postel nezavěšujte žádné věci, do kterých by se děti mohly při hraní zachytit, například pásek, šňůru, atd.** Návod k montáži pečlivě uschovejte.

SLOVENSKY

ajskôr namontujte rámy postele podľa priloženého návodu. Po ukončení montáže Vám zostanú prebytočné časti nábytku. Počet týchto dielov závisí od toho, aký model si na montáž zvolíte.

DOLEŽITÉ! Nevešajte na postel' veci, s ktorými sa deti môžu hrať, napr. povraz, opasok...

Inštrukcie si uschovajte pre prípad potreby.

MAGYAR

Először az ágykeretet szereld össze - ennek útmutatója az ágykeretek csomagolásában található. A szerelés végeztével marad néhány csavar és alkatrész. Ezek száma attól függ, melyik összeszerelési modellt választottad.

FONTOS! Ne akassz különböző dolgokat az ágyra, melyekbe gyermeked esetleg beleakadhat pl. játék közben. Az összeszerelési útmutatót őrizd meg!

РУССКИЙ

Сначала соберите обвязку/и кровати. Инструкция по сборке прилагается к обвязке/ам кровати. После сборки у Вас останется арматура и элементы мебели. Количество оставшихся деталей зависит от модели, которую Вы выбрали для сборки. **ВНИМАНИЕ! Не вешайте на кровать вещи, в которых ребенок может запутаться во время игры, например: перекрученные веревки, ремни и т.д.** Сохраните эту инструкцию.

中文

首先安装床框架。床框架附安装说明。框架安装完成后，会余出其它床具安装件和组配件。床具安装模式不同，剩出的床具件的数量会不同。警告！勿在床具上悬挂任何物品如绳子、皮带等，以免在孩子玩耍时受到意外伤害。妥善保存产品说明材料，备今后参考。

日本語

はじめにベッドフレームを組み立ててください。組立説明書はベッドフレームに添付されています。組み立て終了後、留め具や家具部品が数点残ります。余りパーツの数は組み立てたモデルにより異なります。重要！ロープの輪、ベルトなど、お子様が遊ぶ際引っかかるようなものをベッドから下げないでください。組立説明書は必要な時にご覧頂けるよう大切に保管してください。

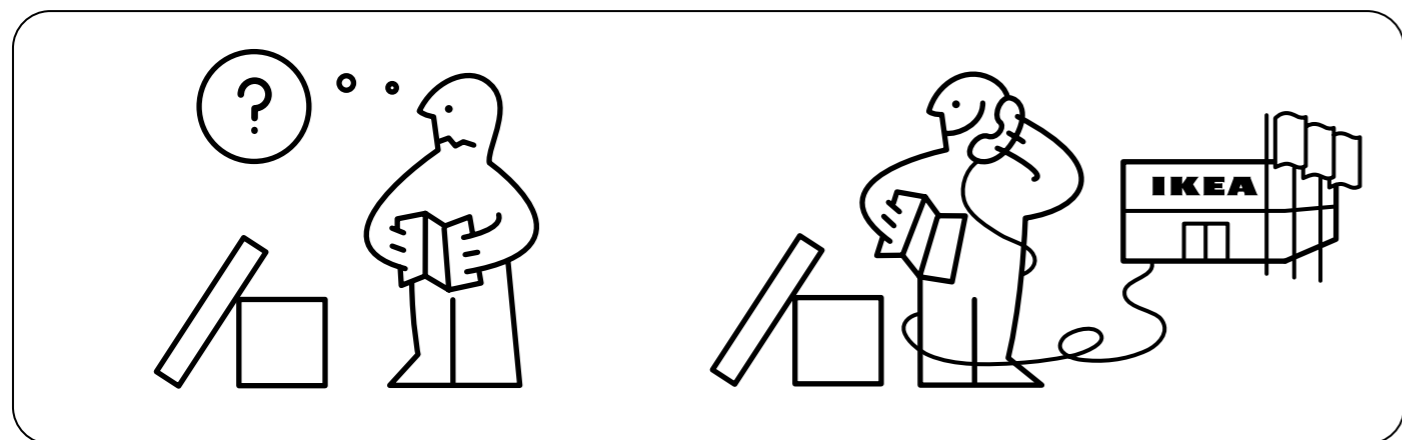
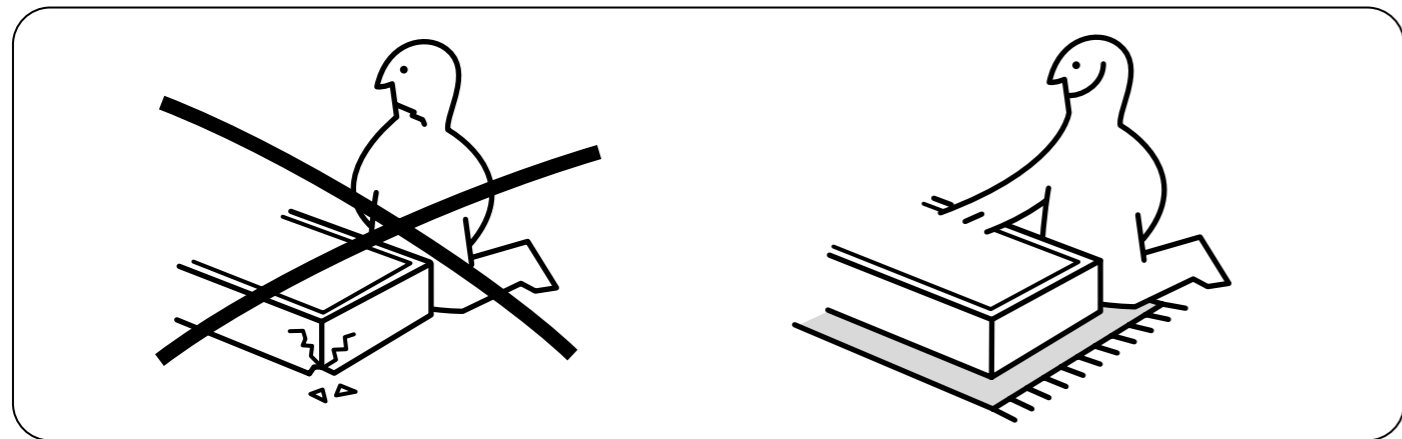
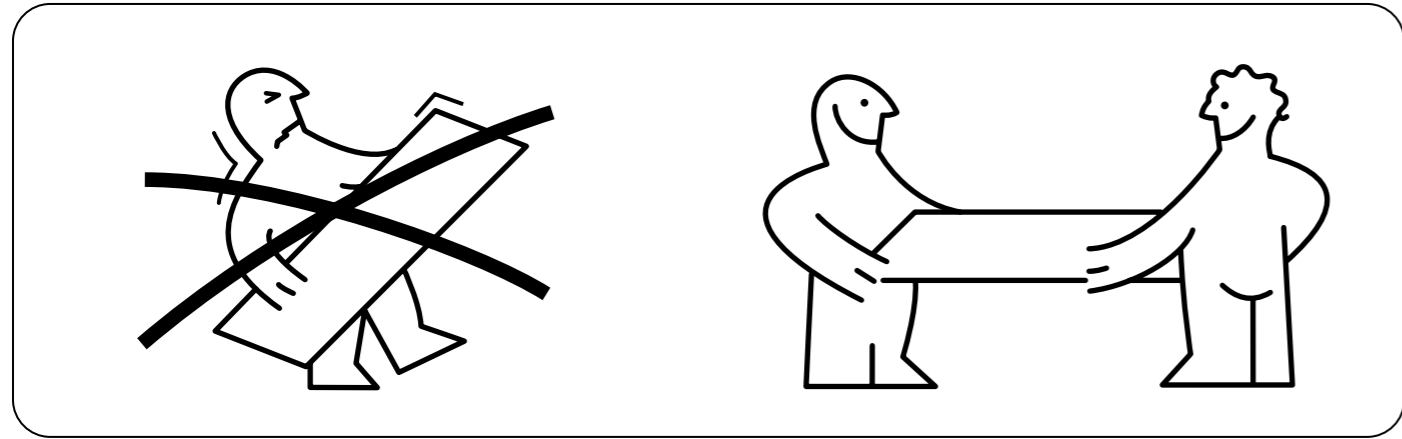
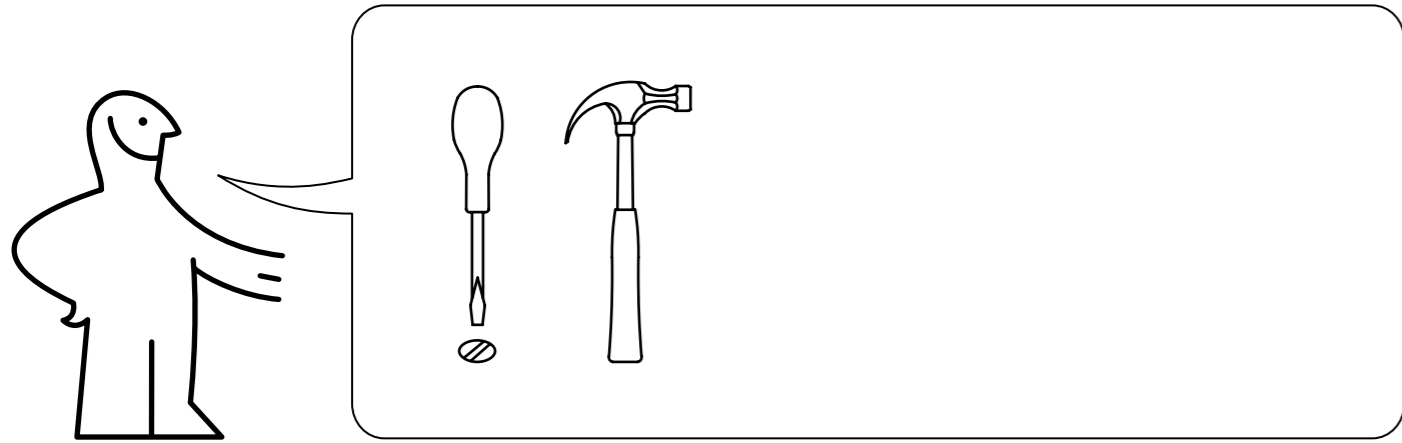

20

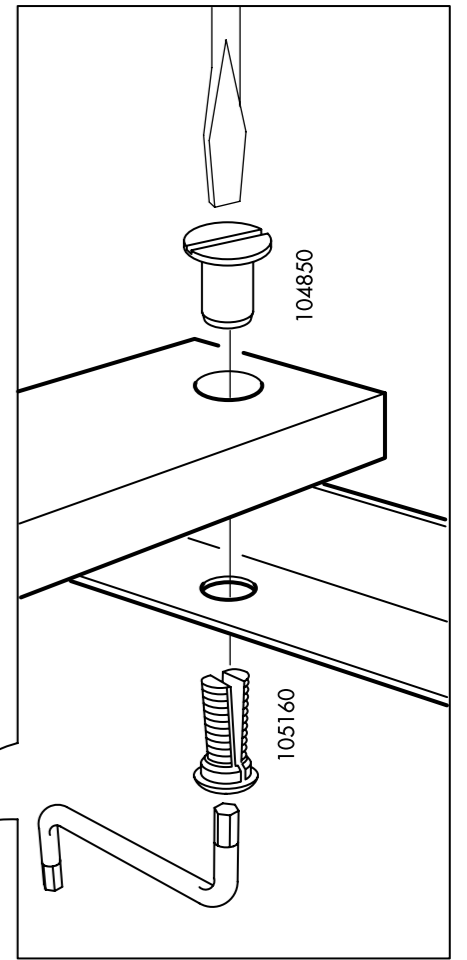
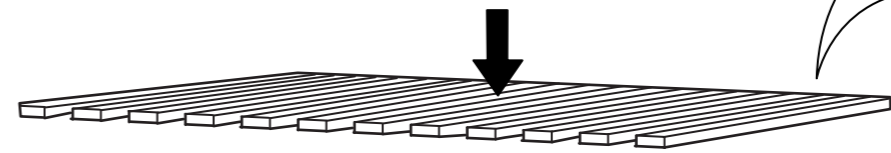

19

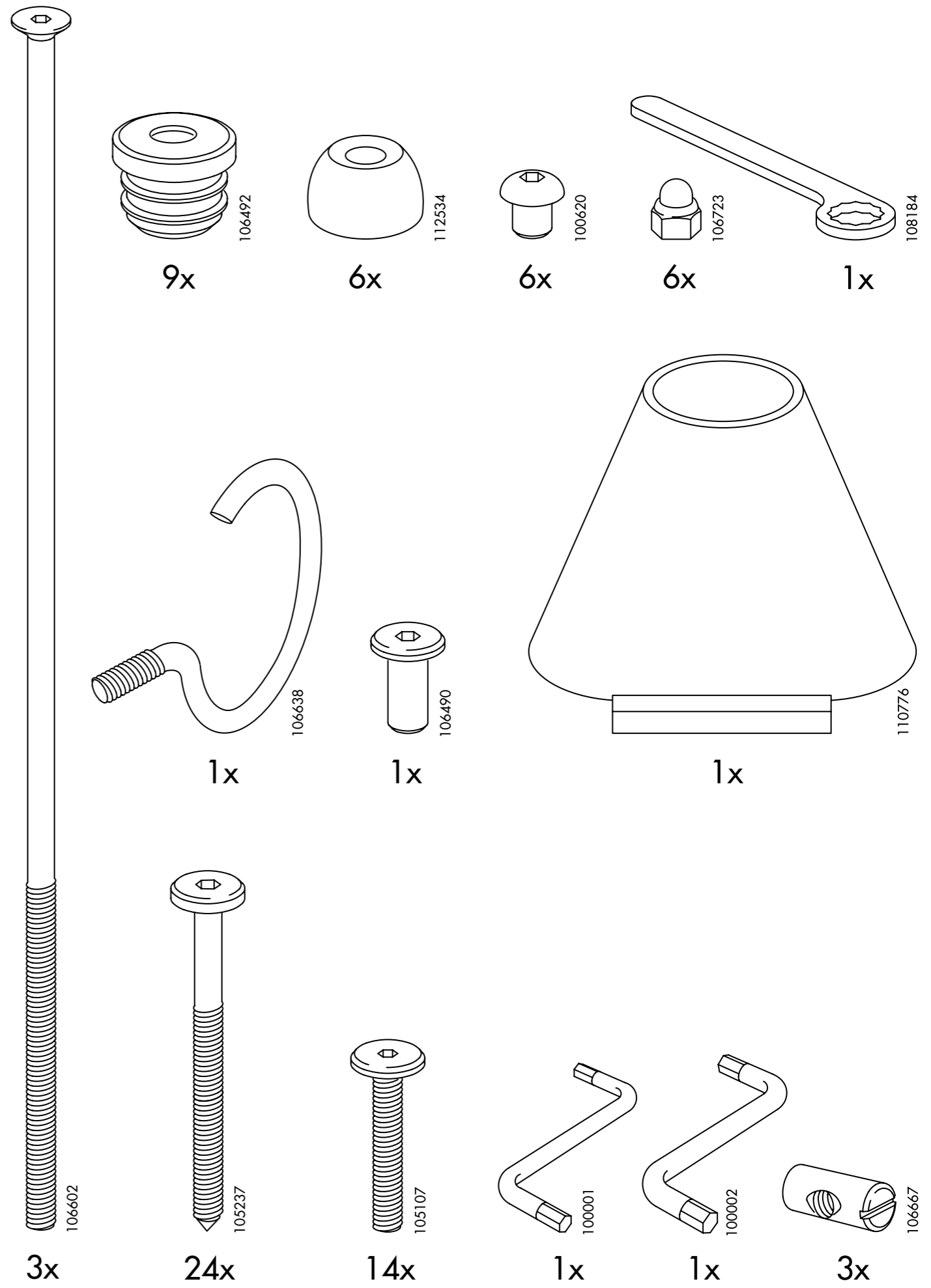
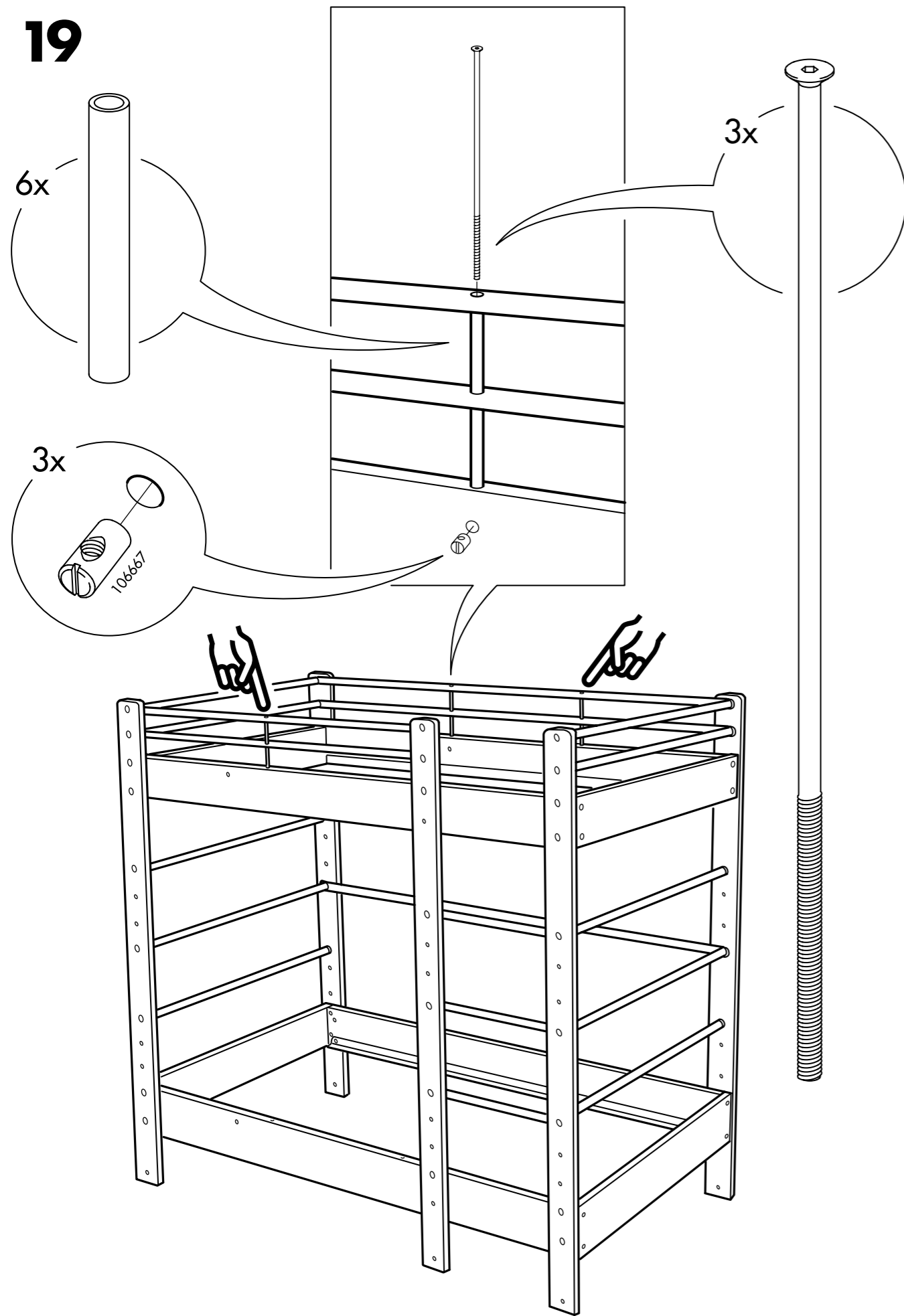

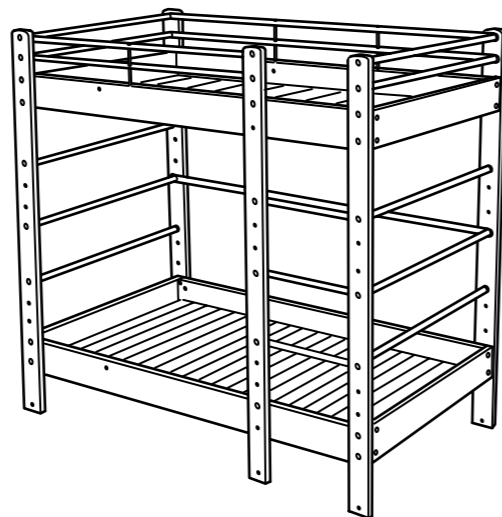
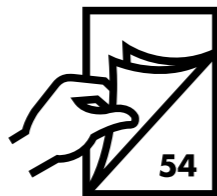
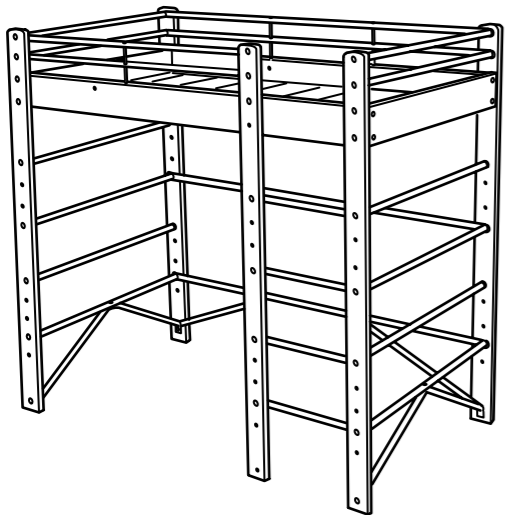
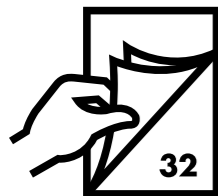
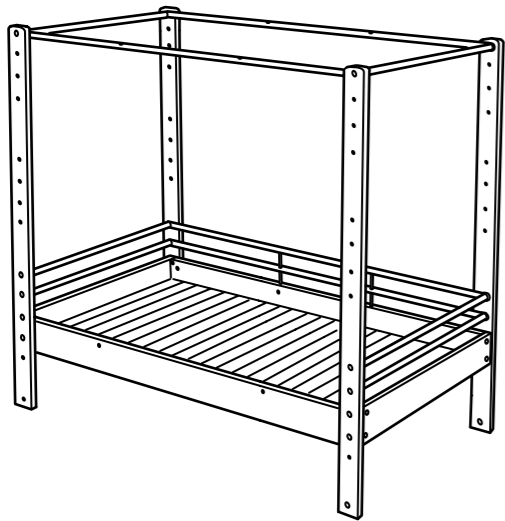
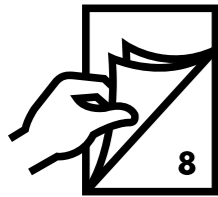

18

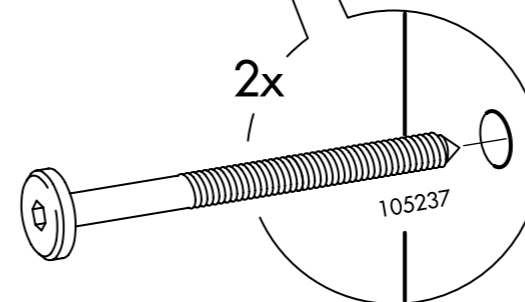
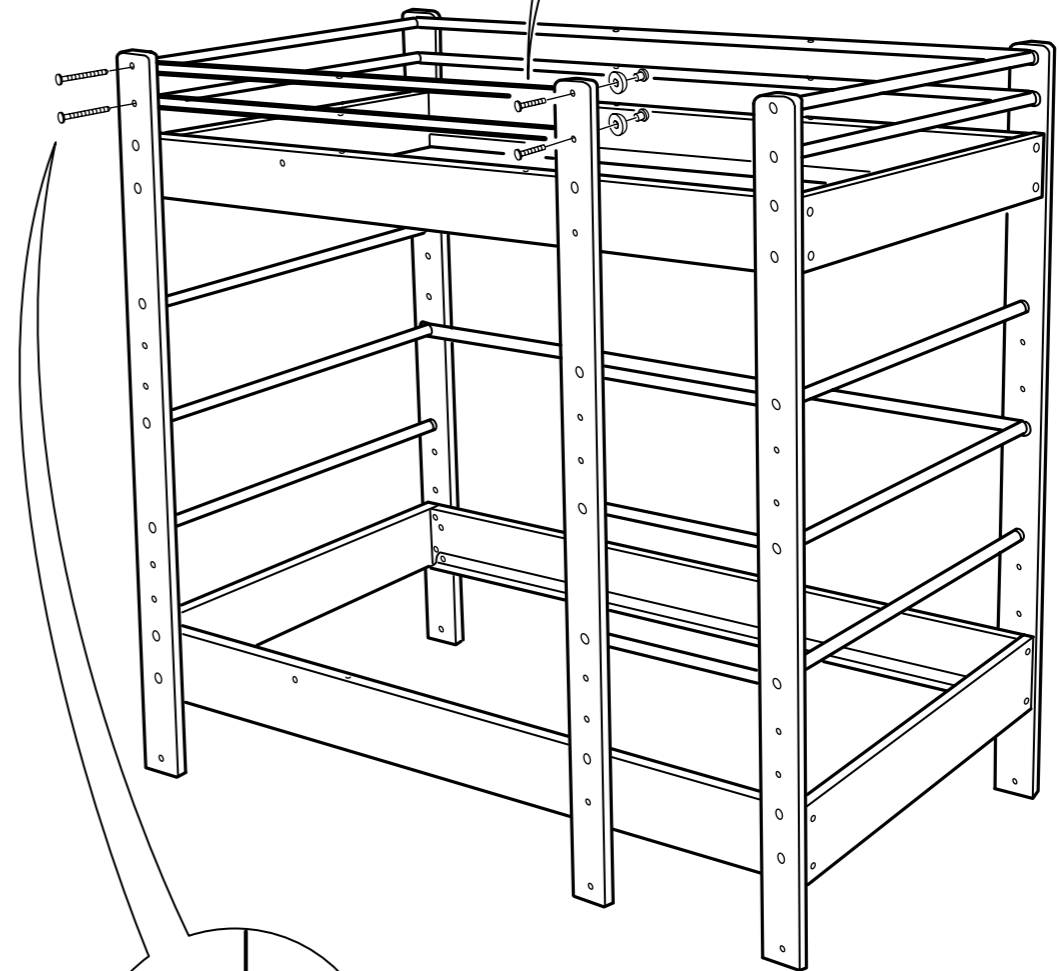
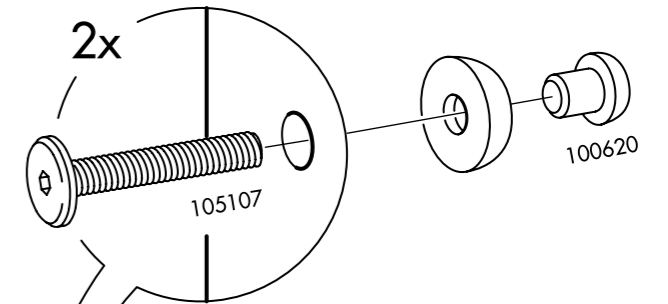
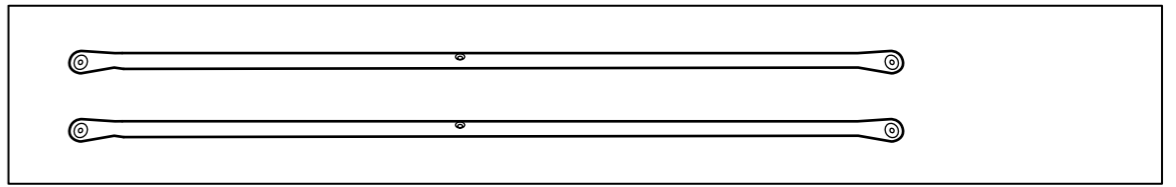

17

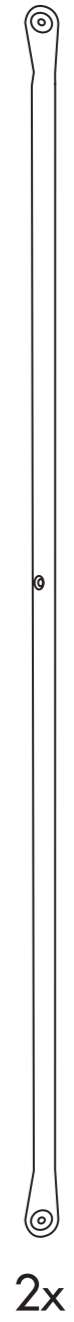
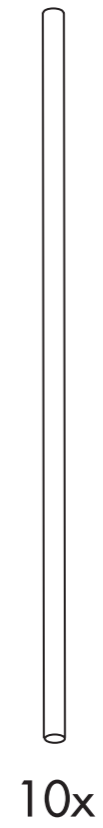
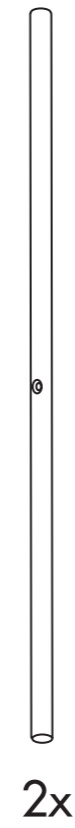
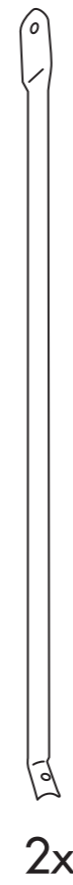
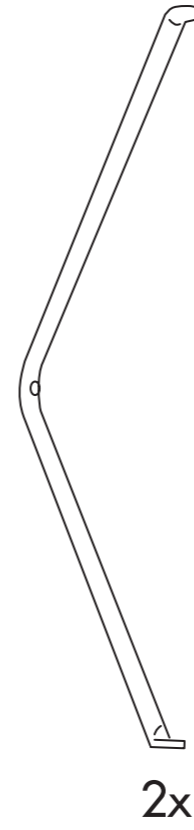
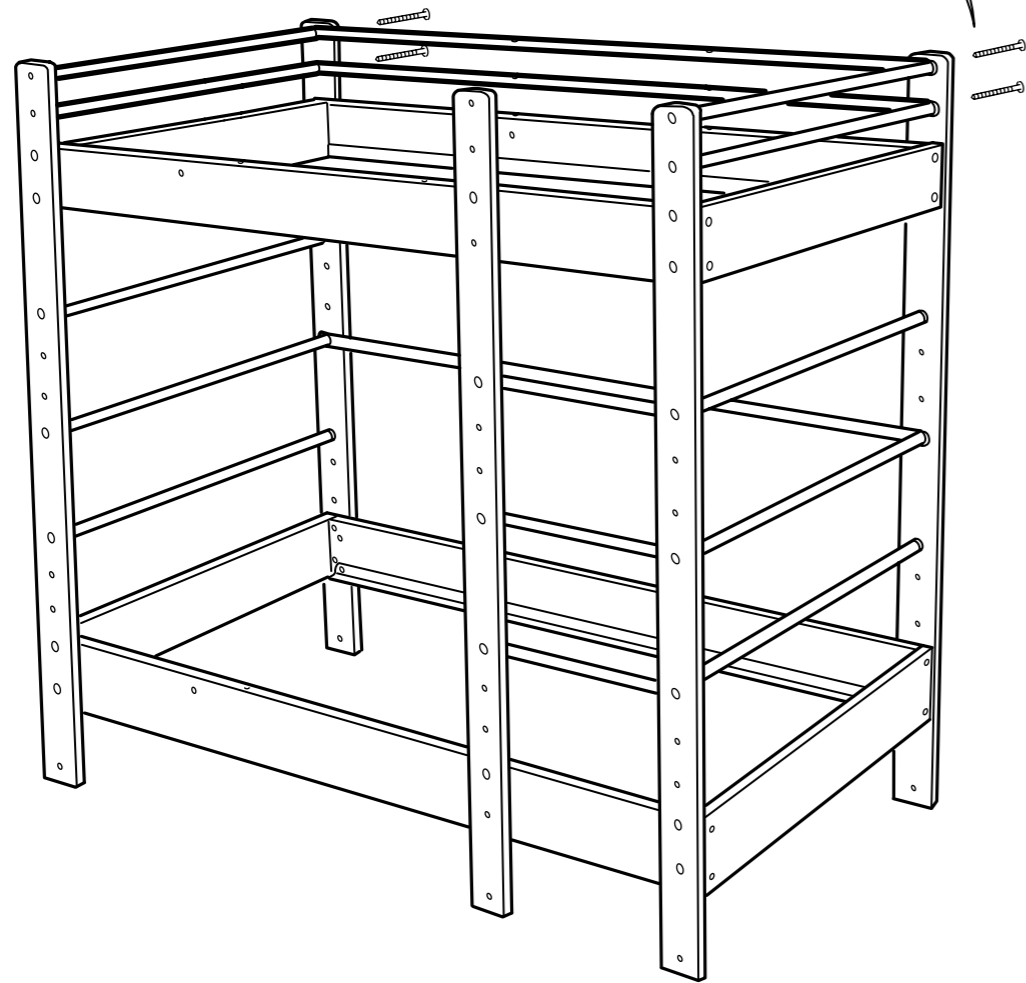
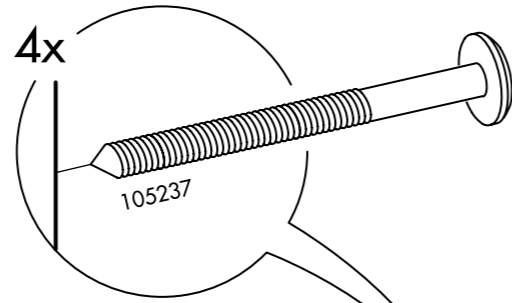
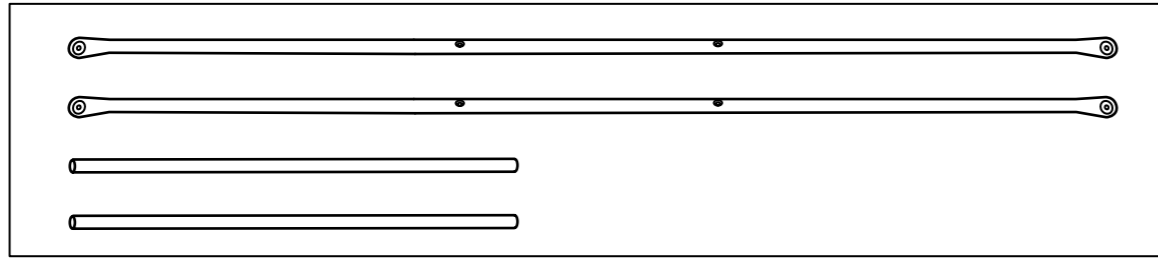

1

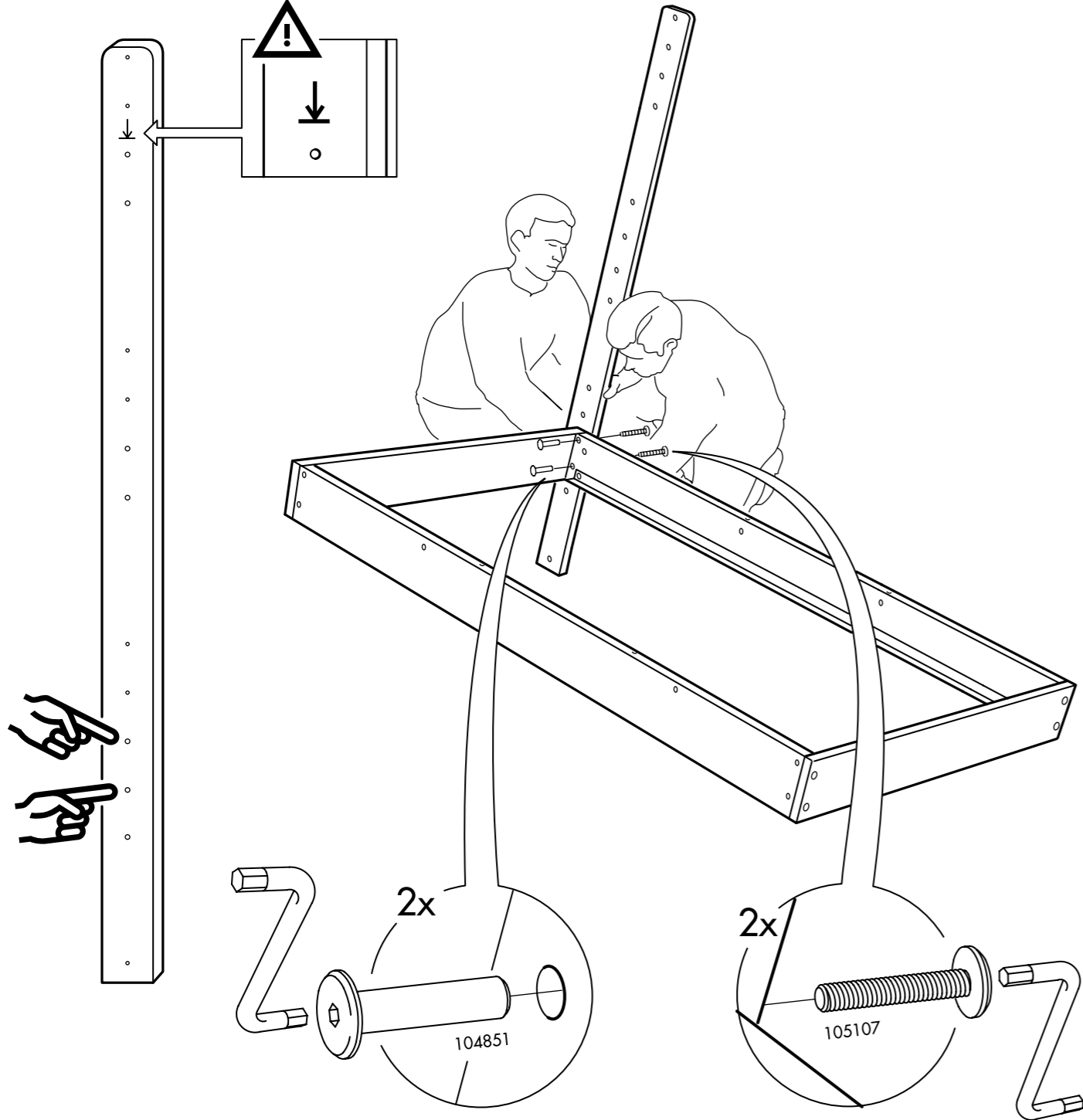
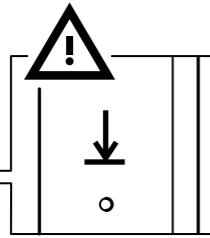
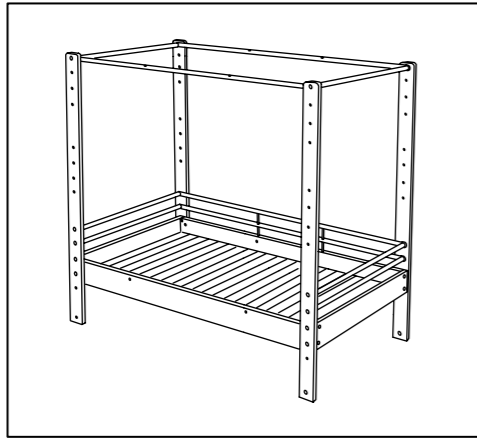

16

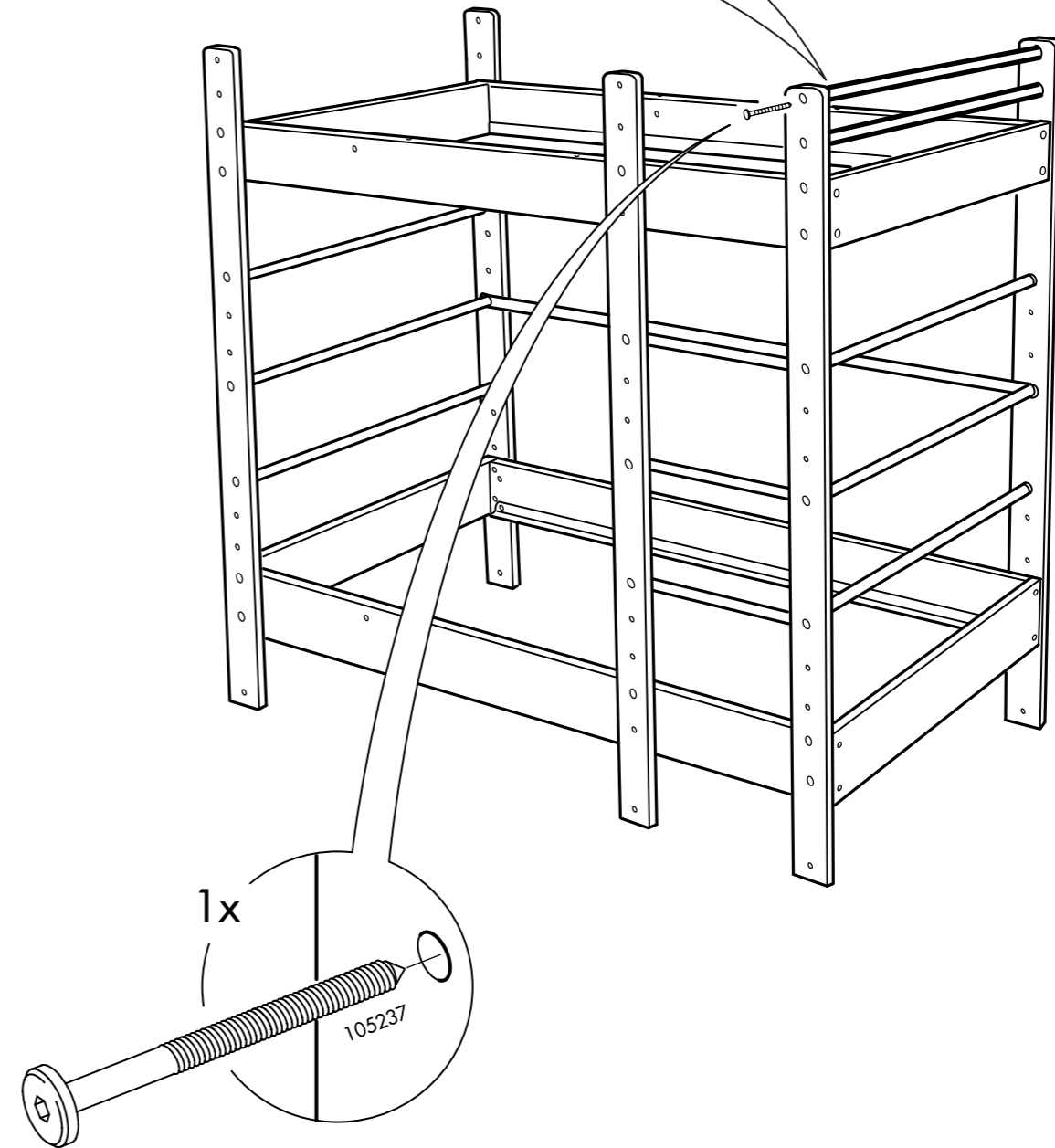
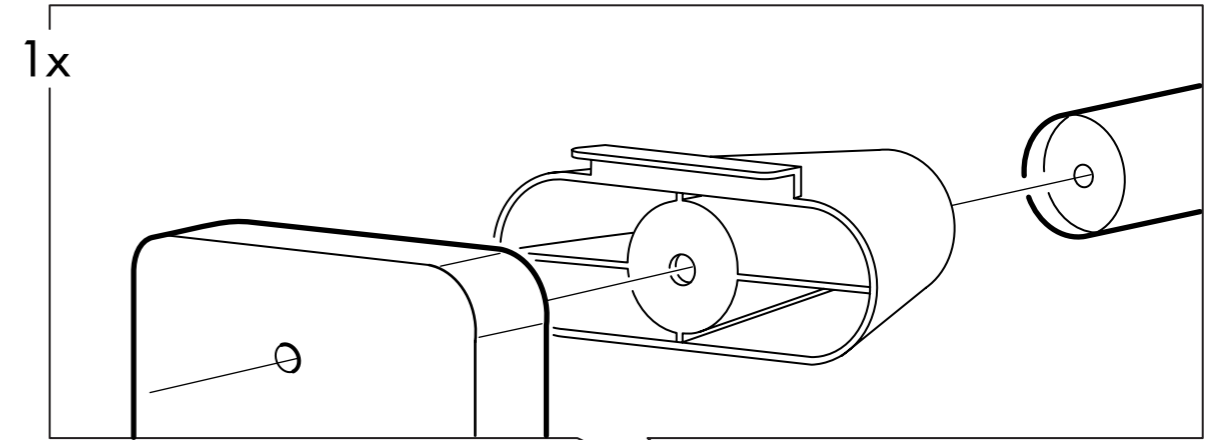
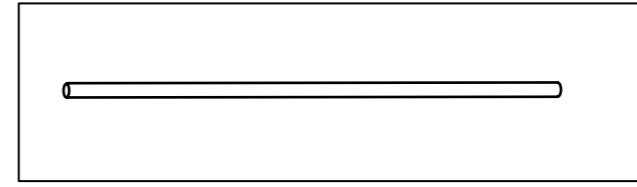

15

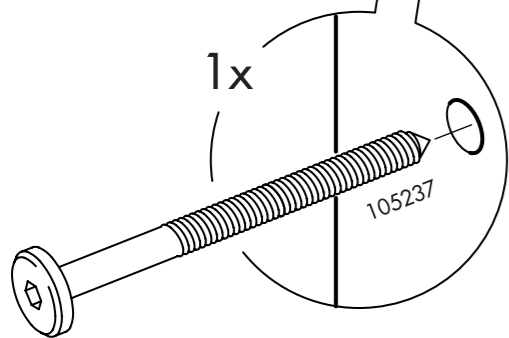
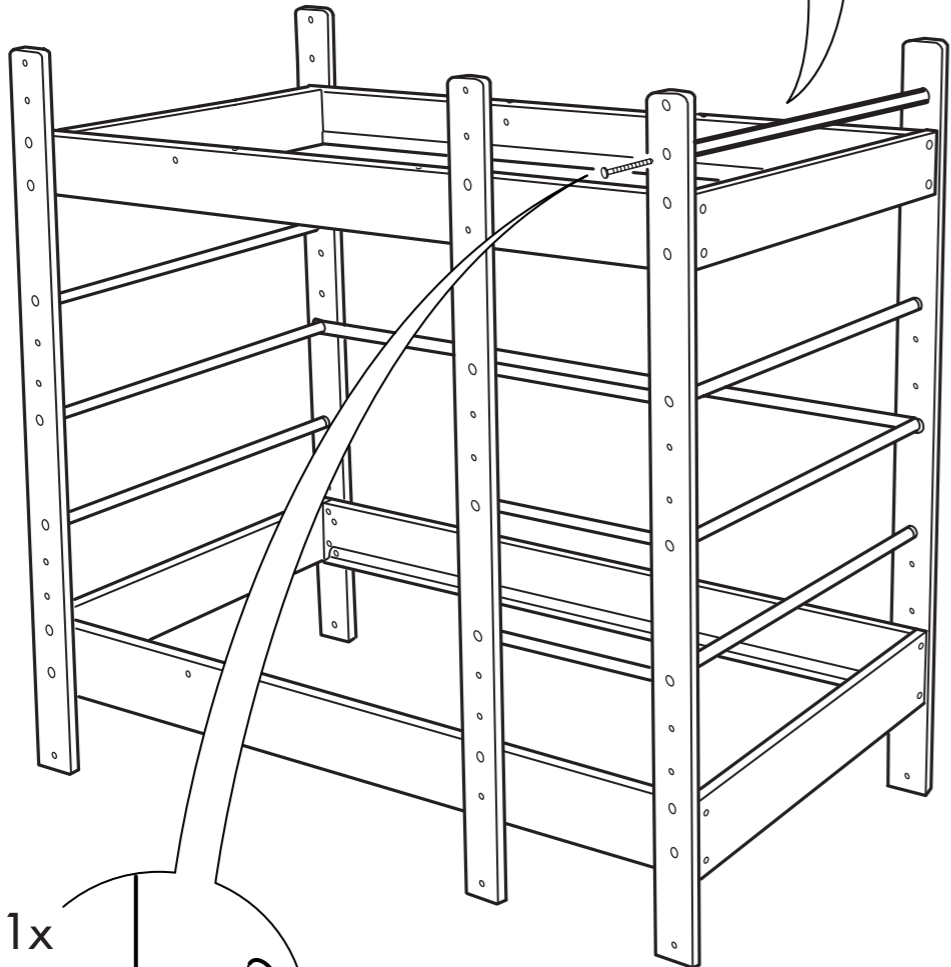
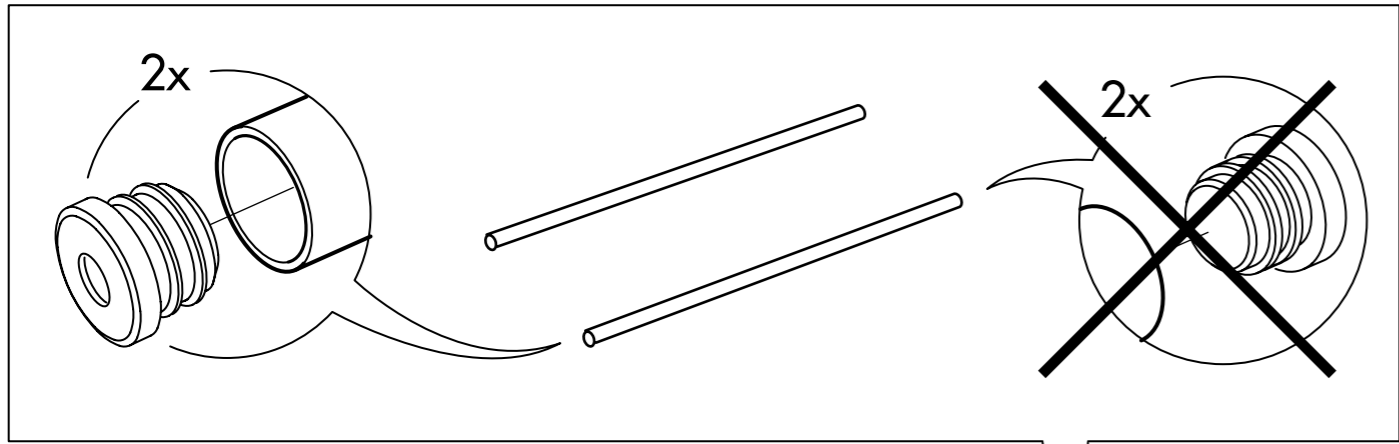
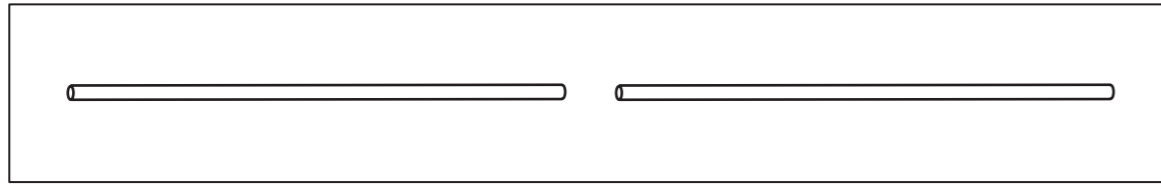

2

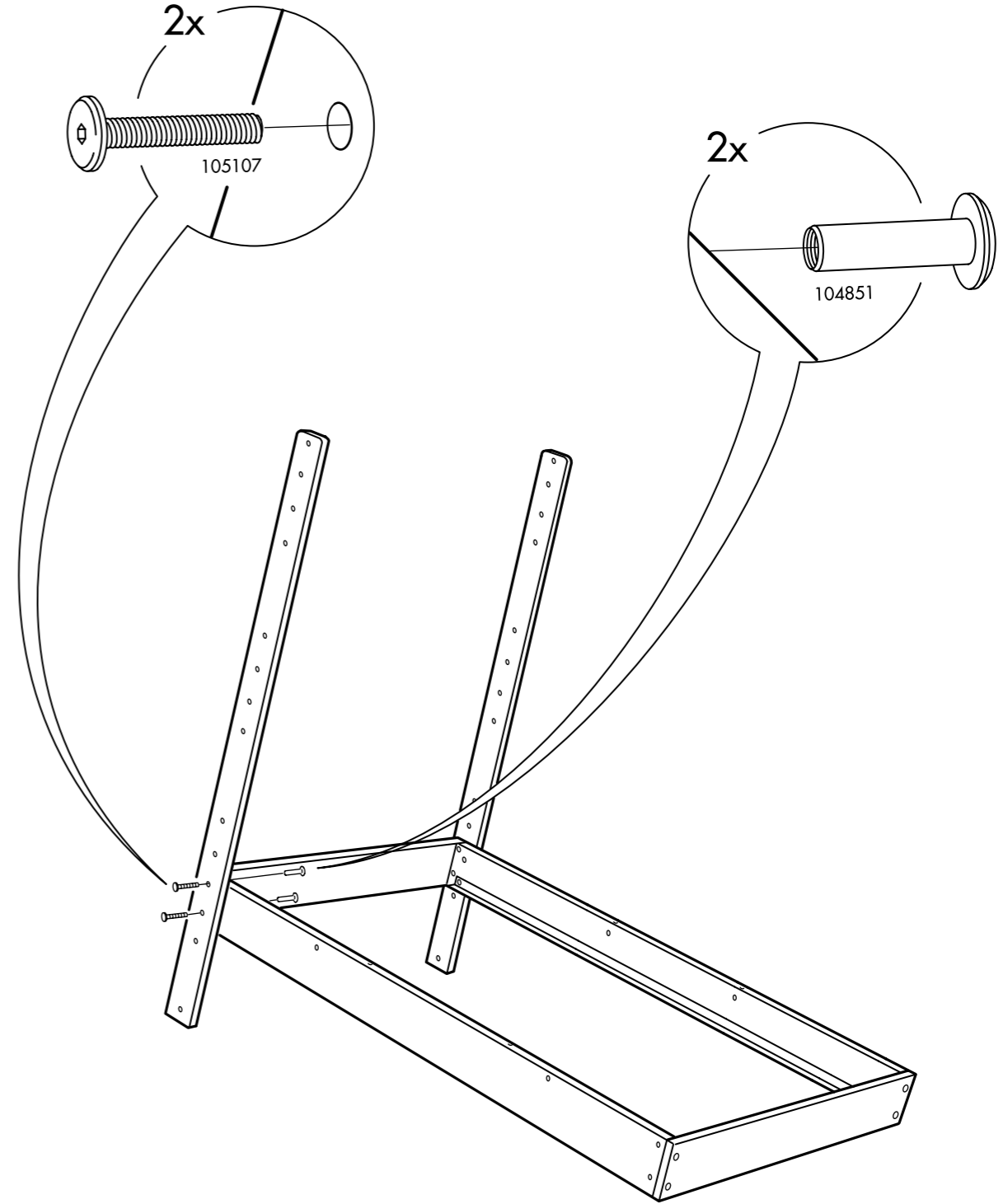

3

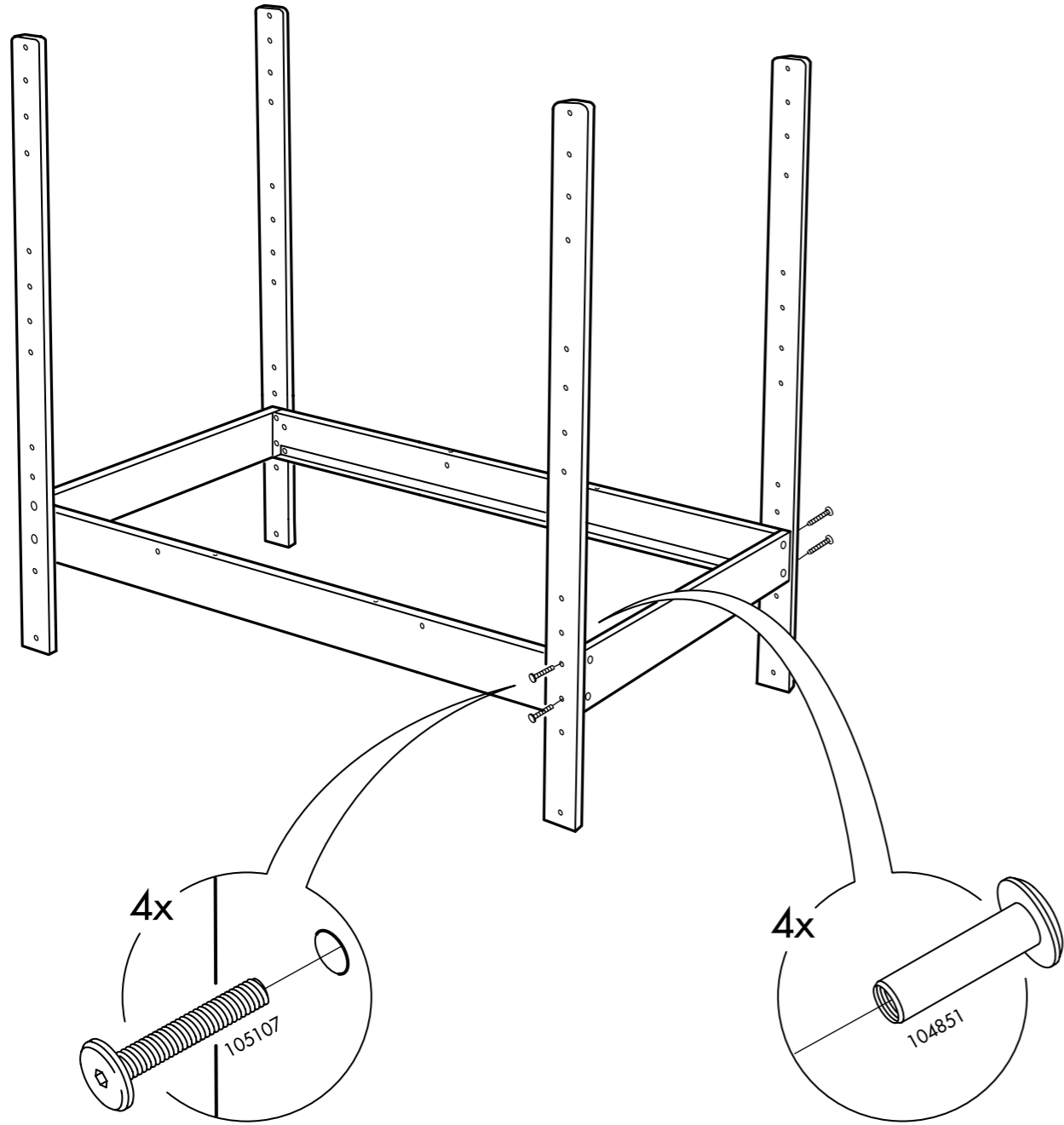

14

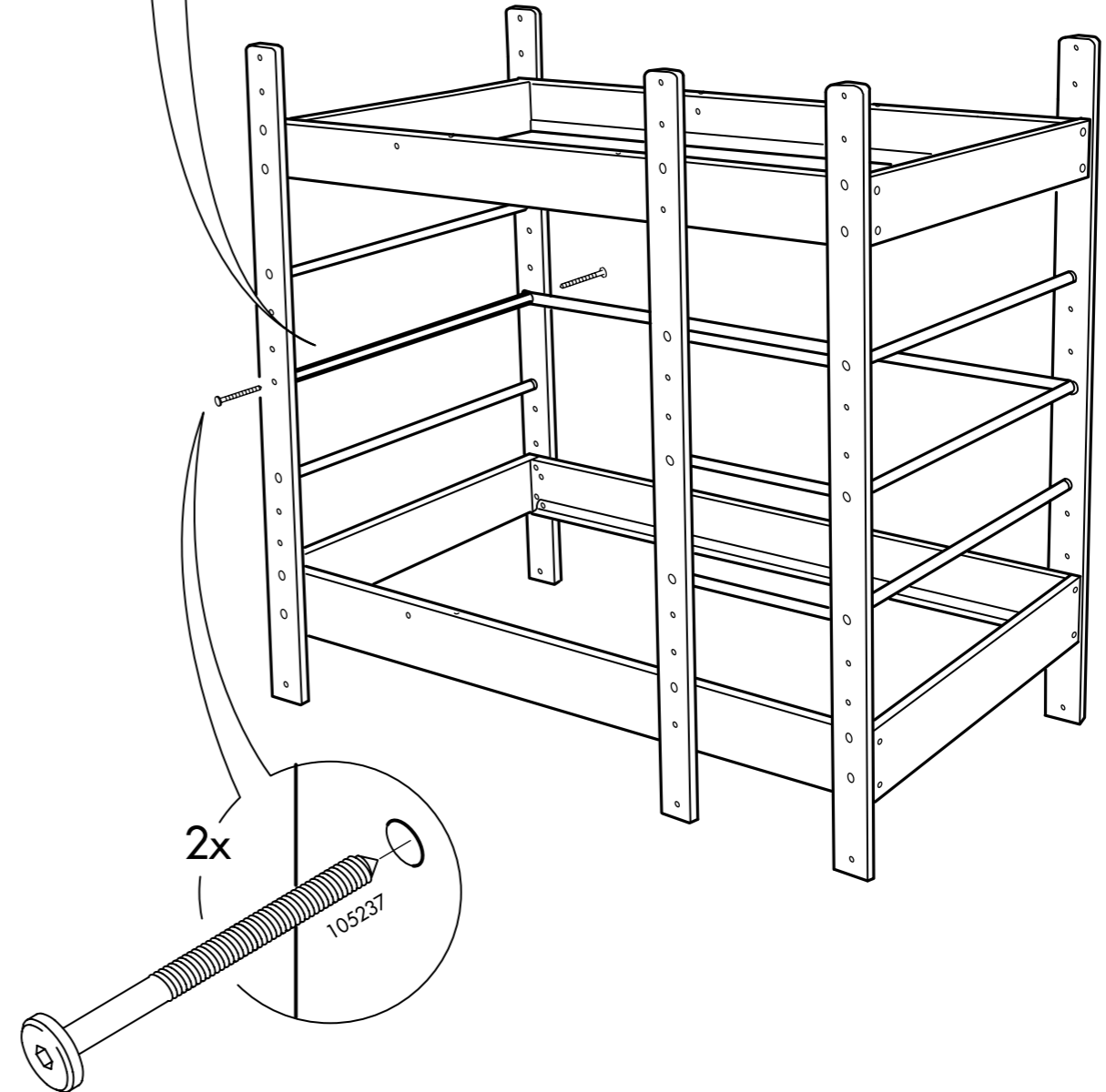
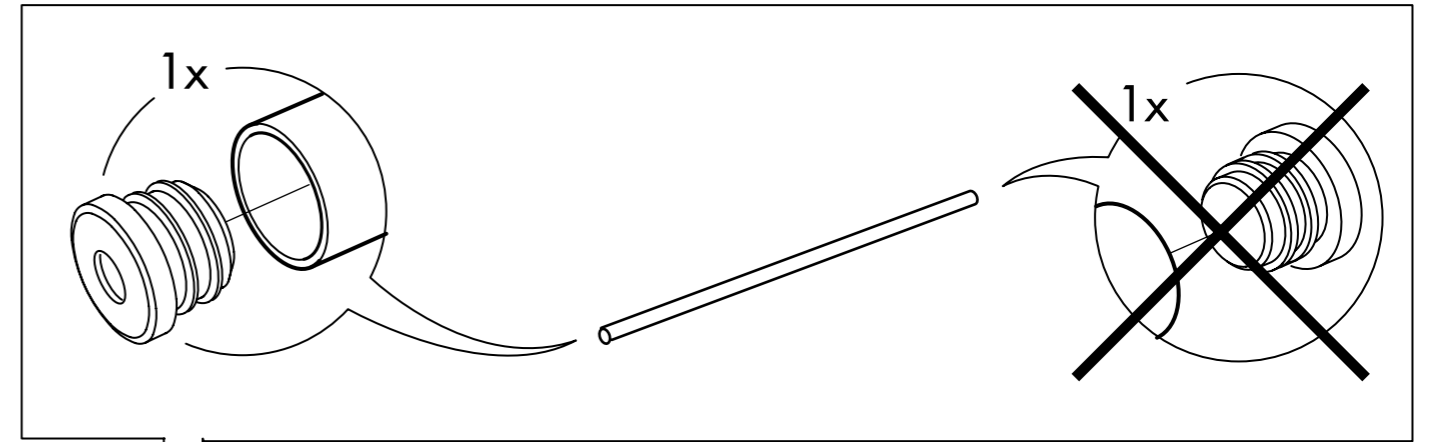
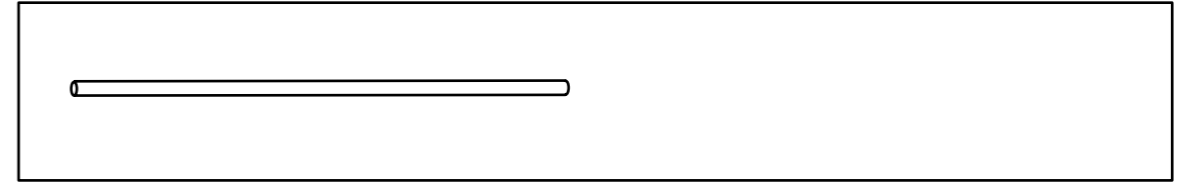

13

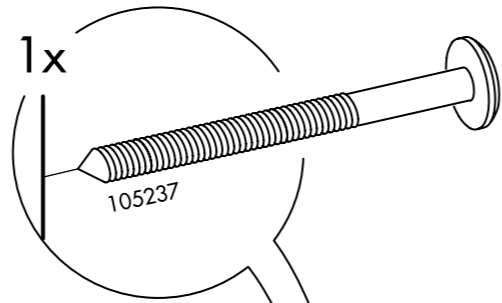
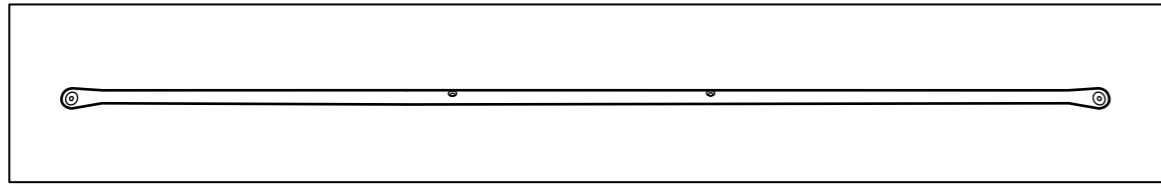

4

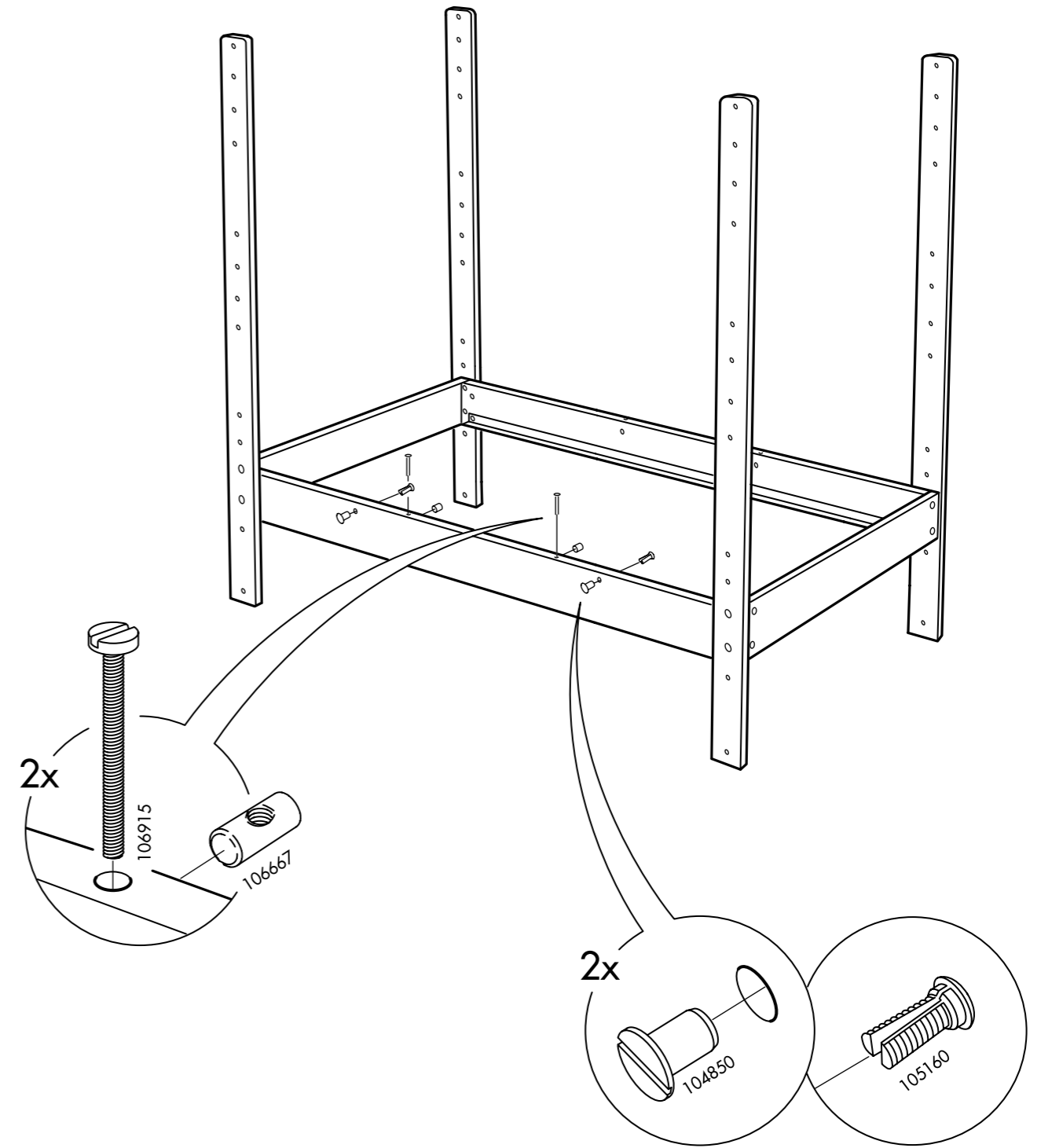

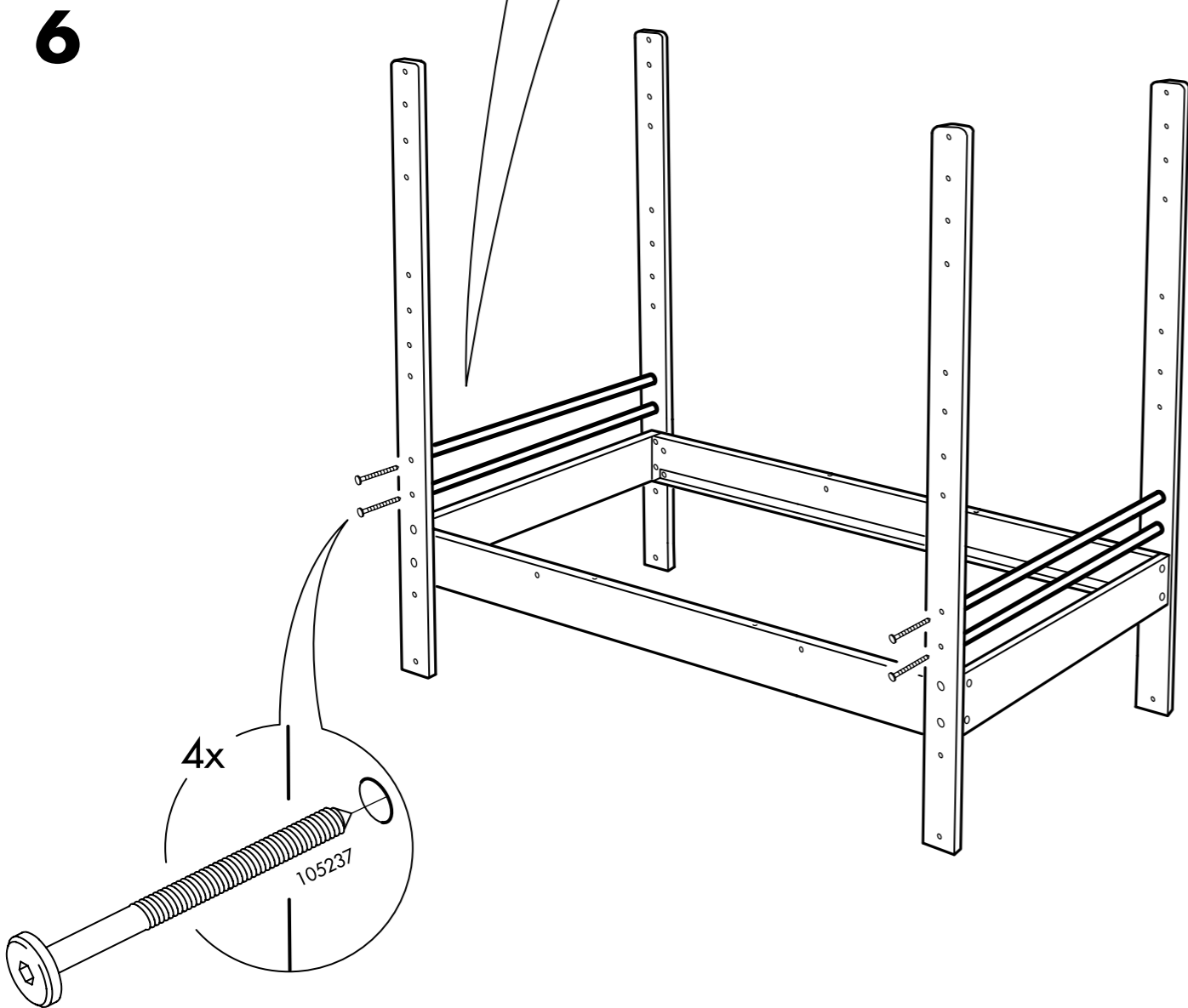
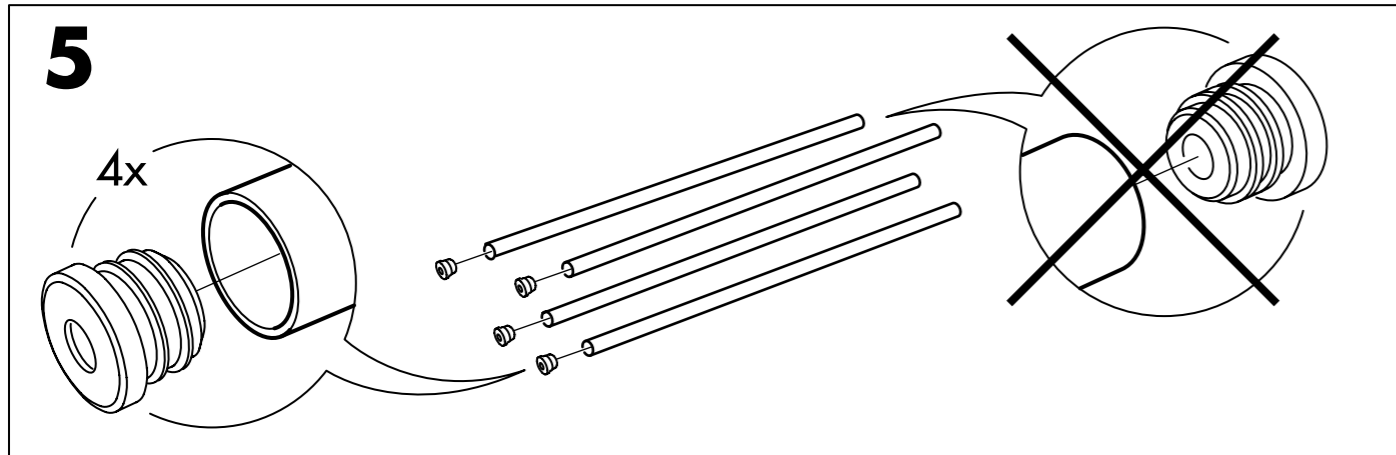
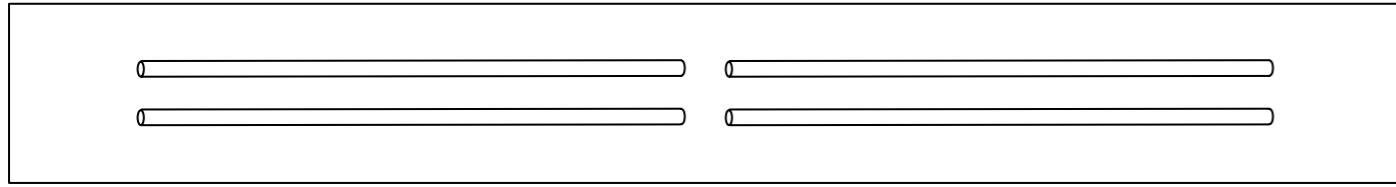

12

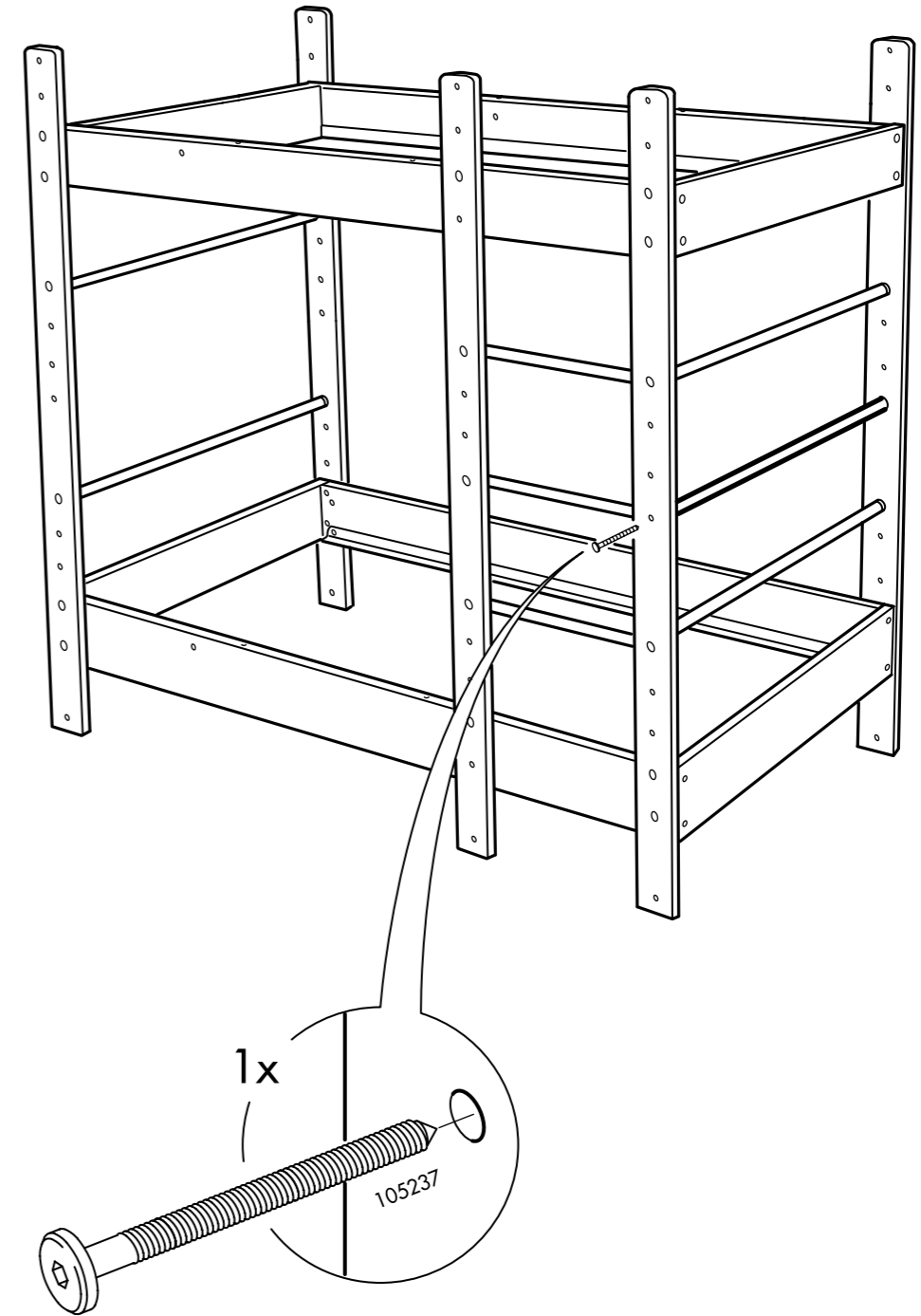
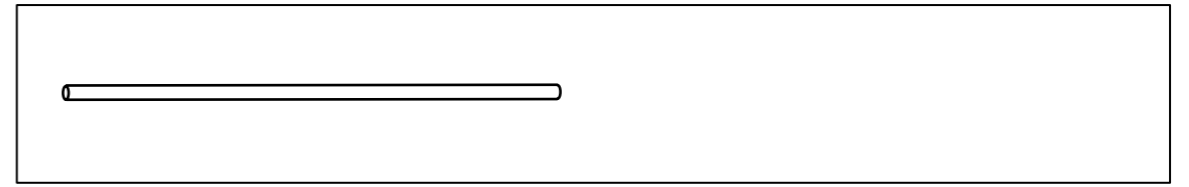

11

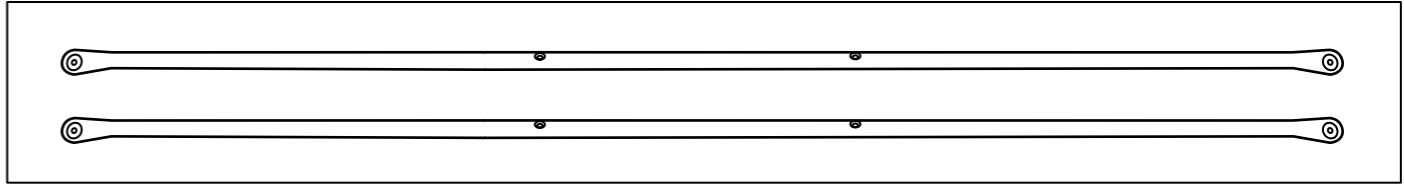
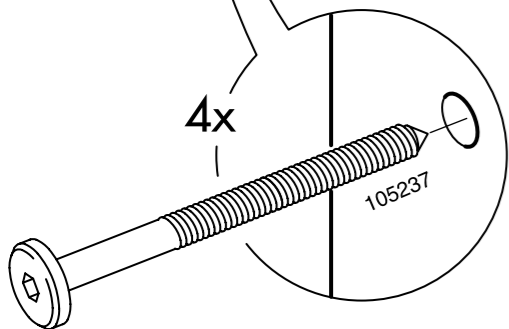
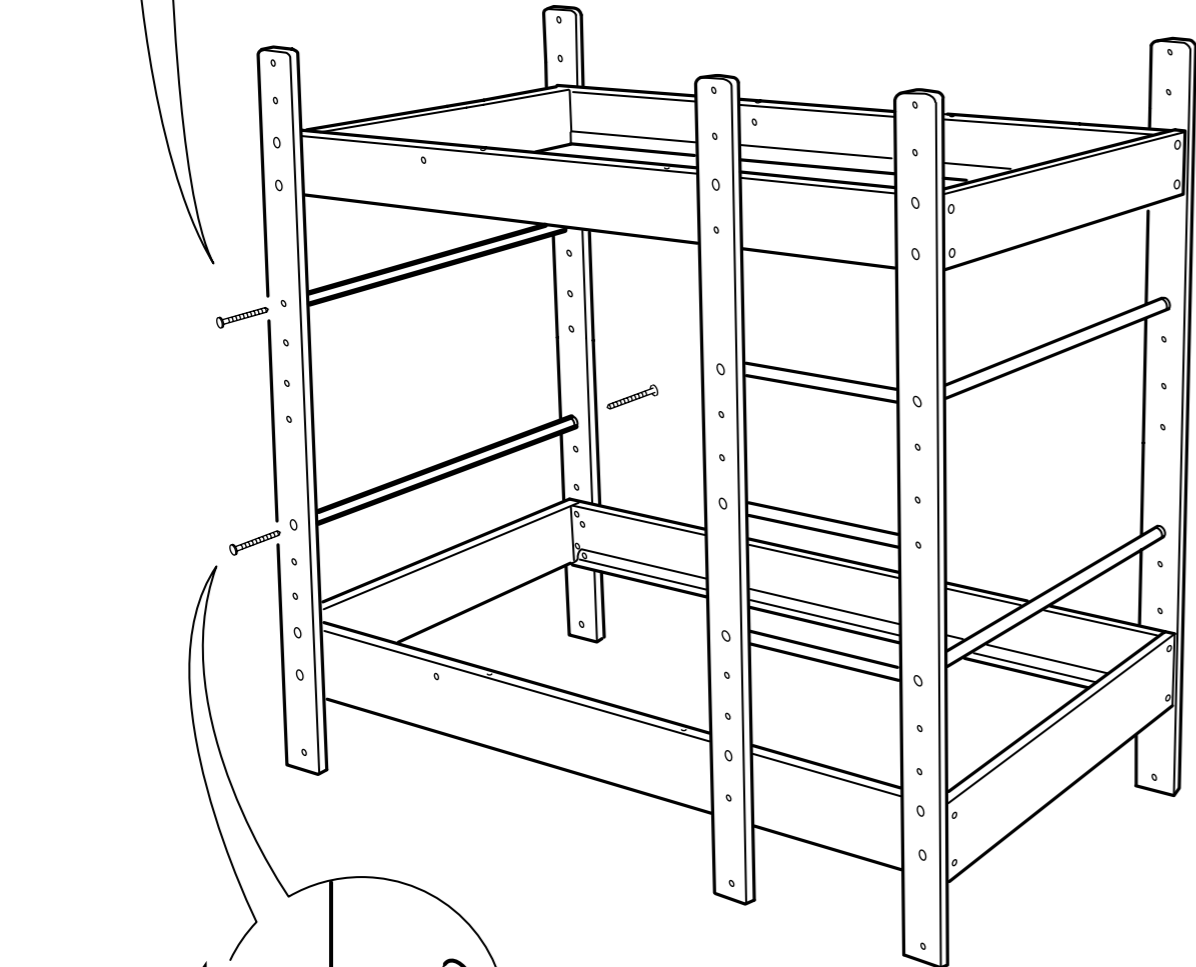
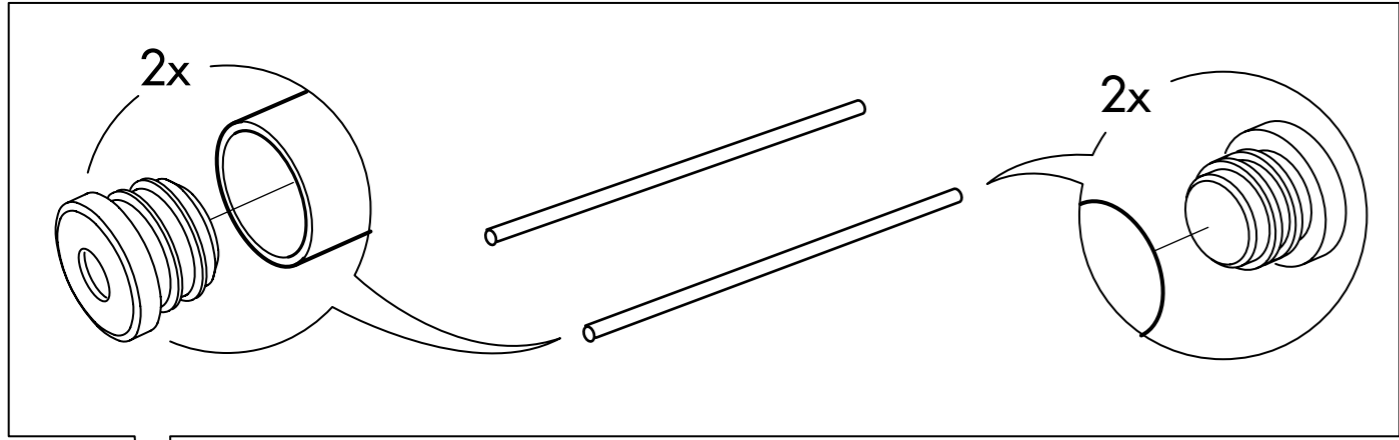
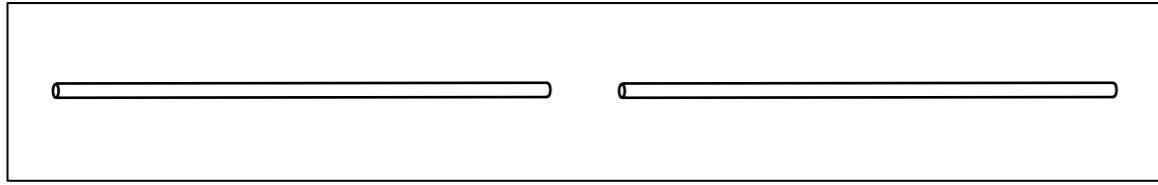

7

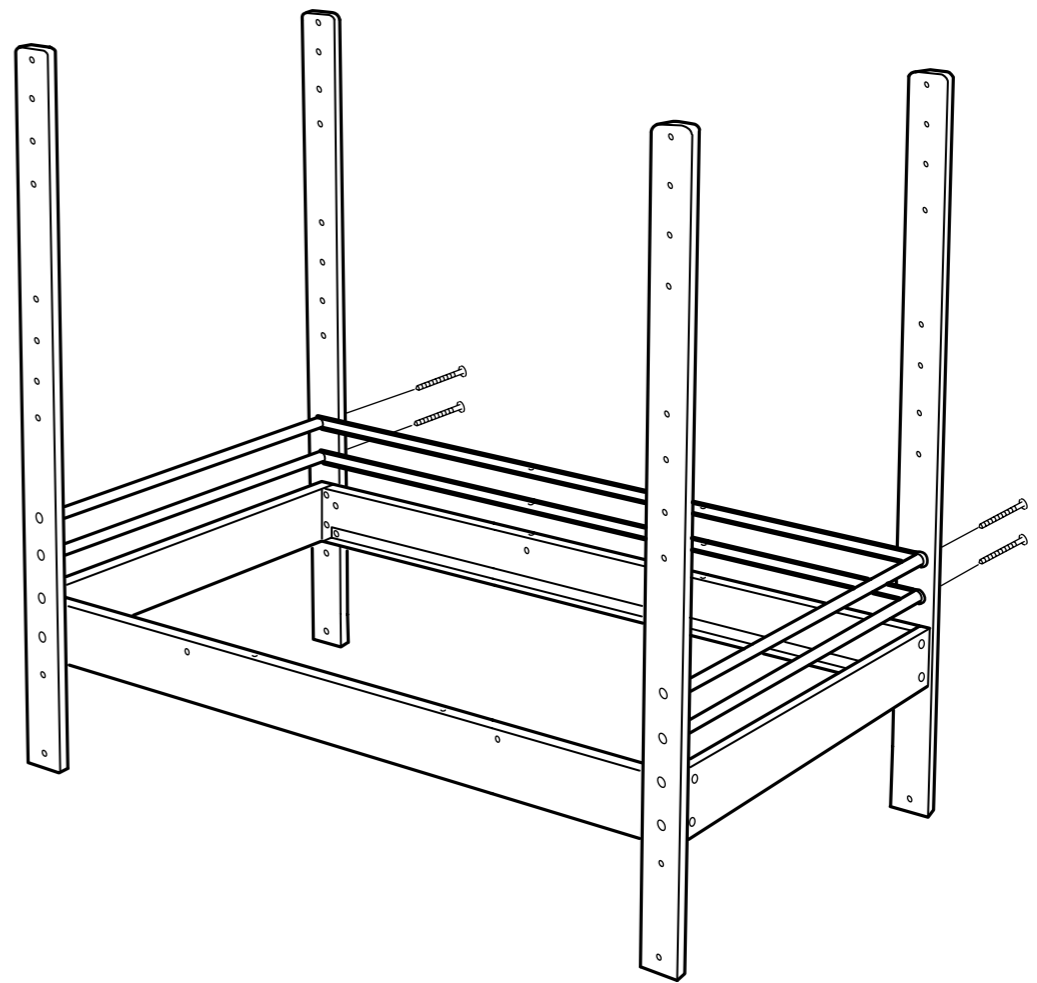
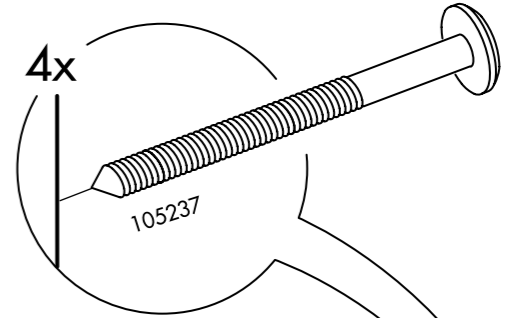

8

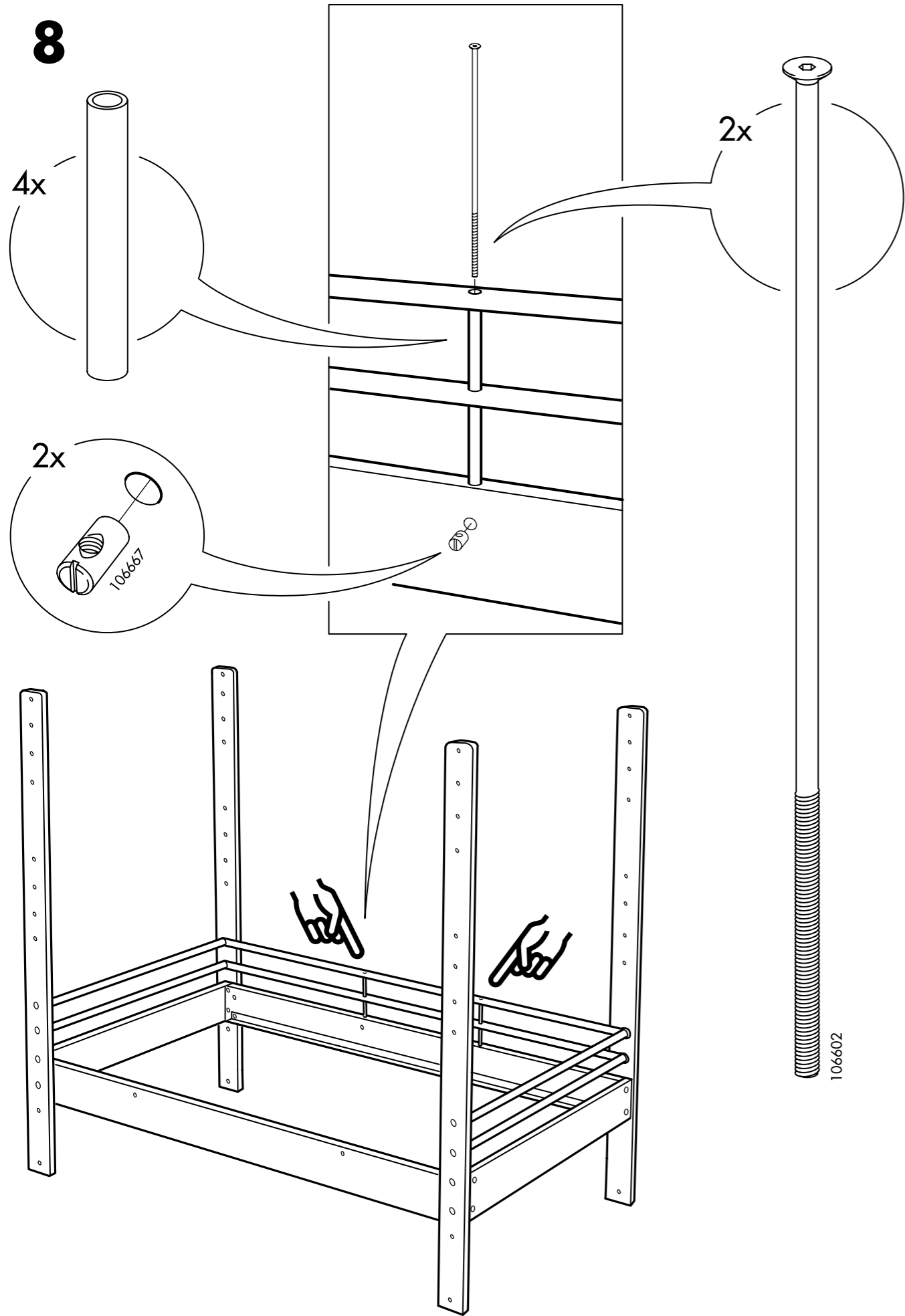

10

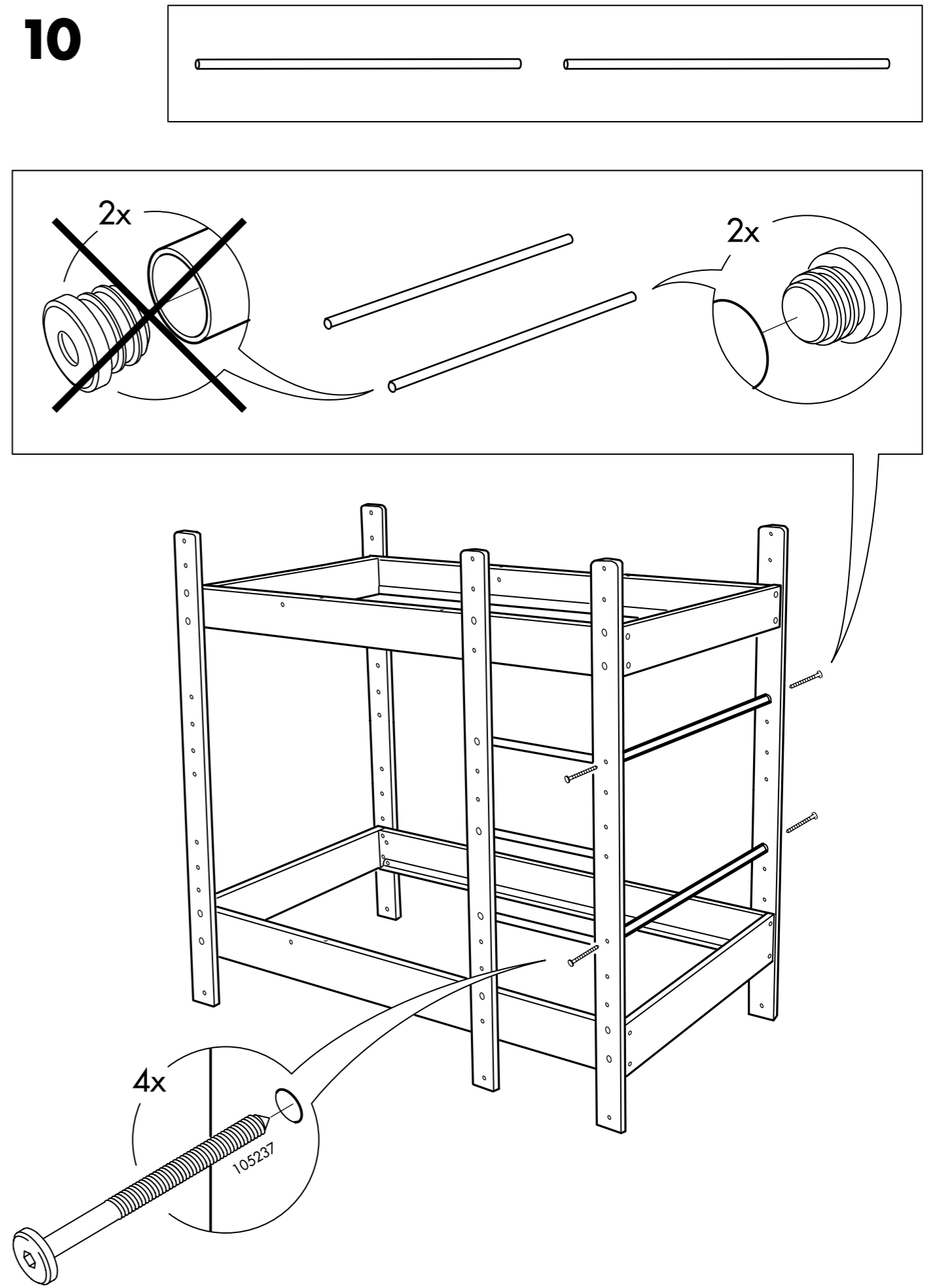

9

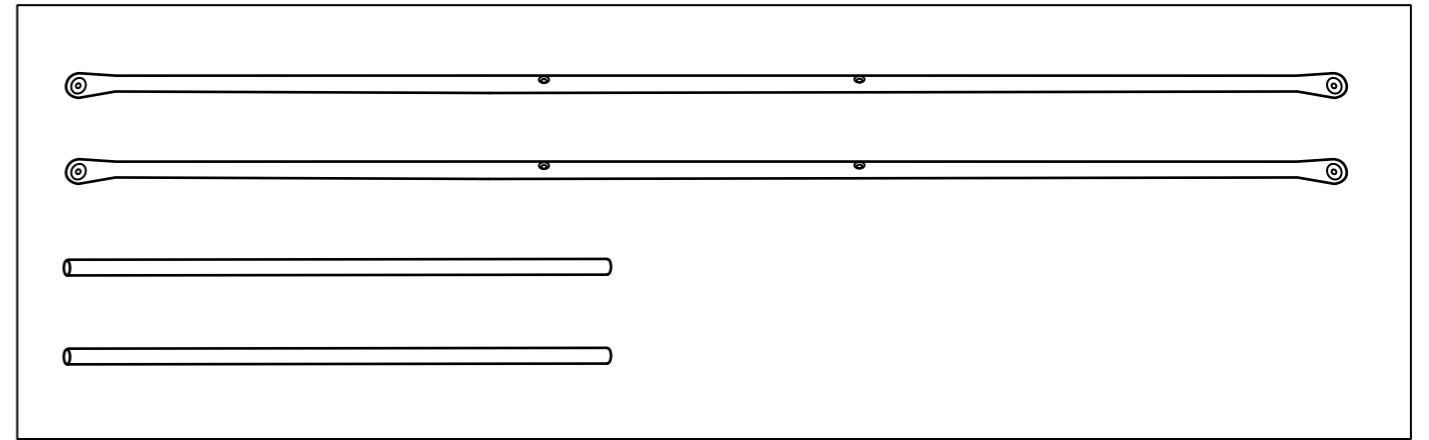
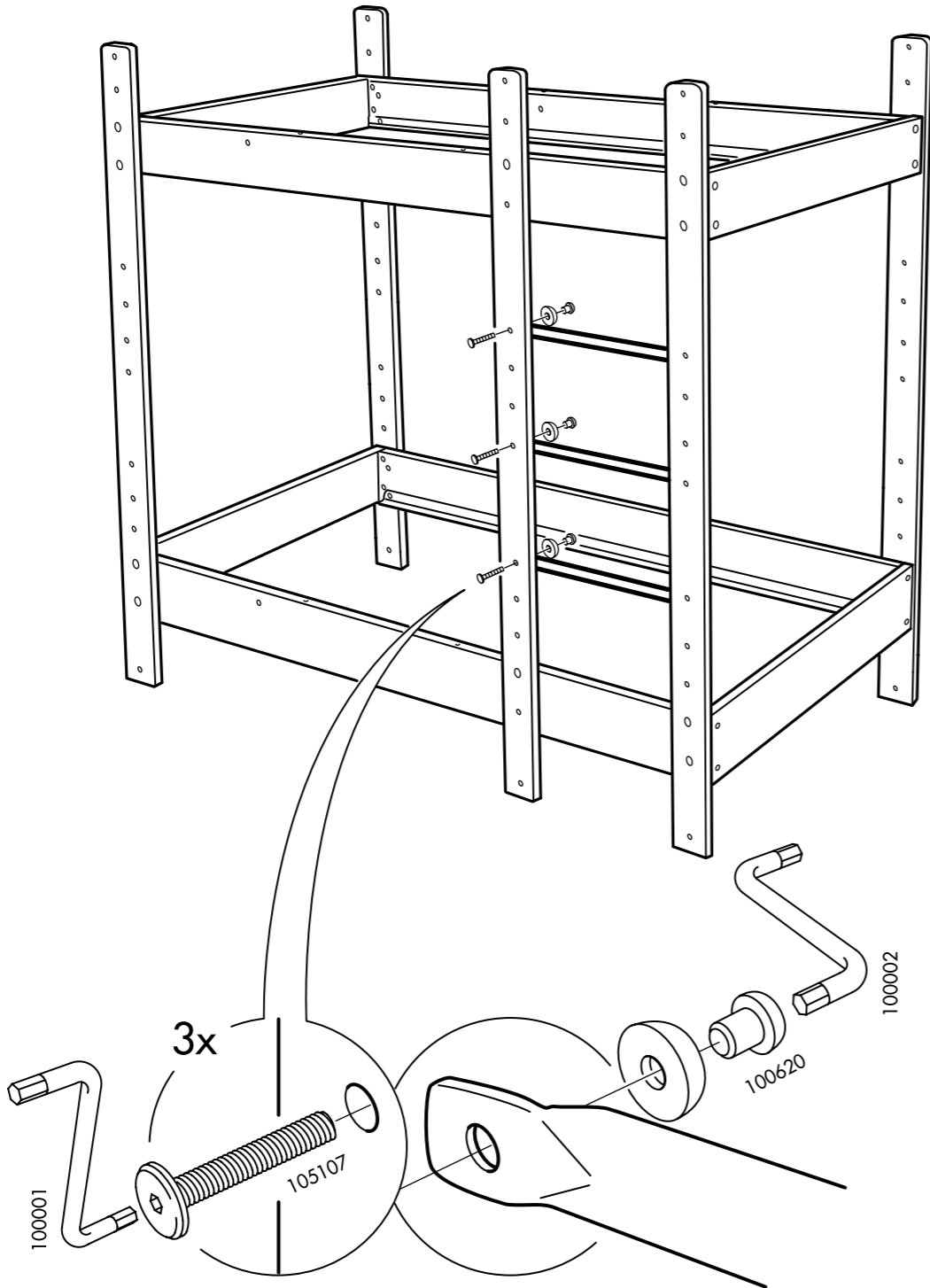
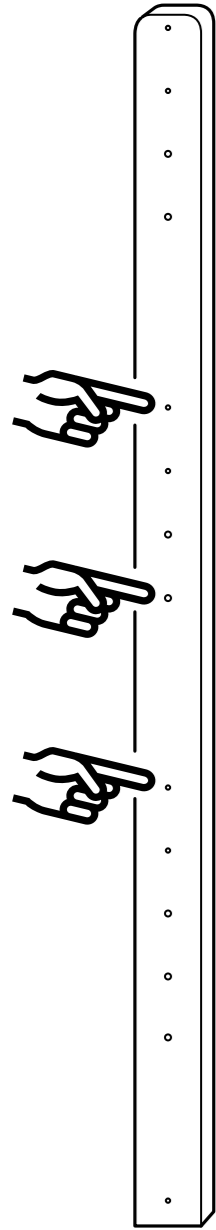
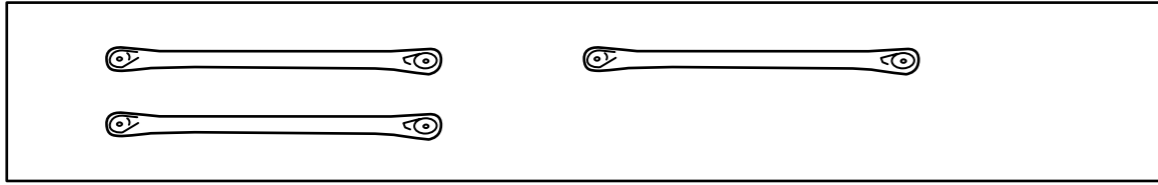

9

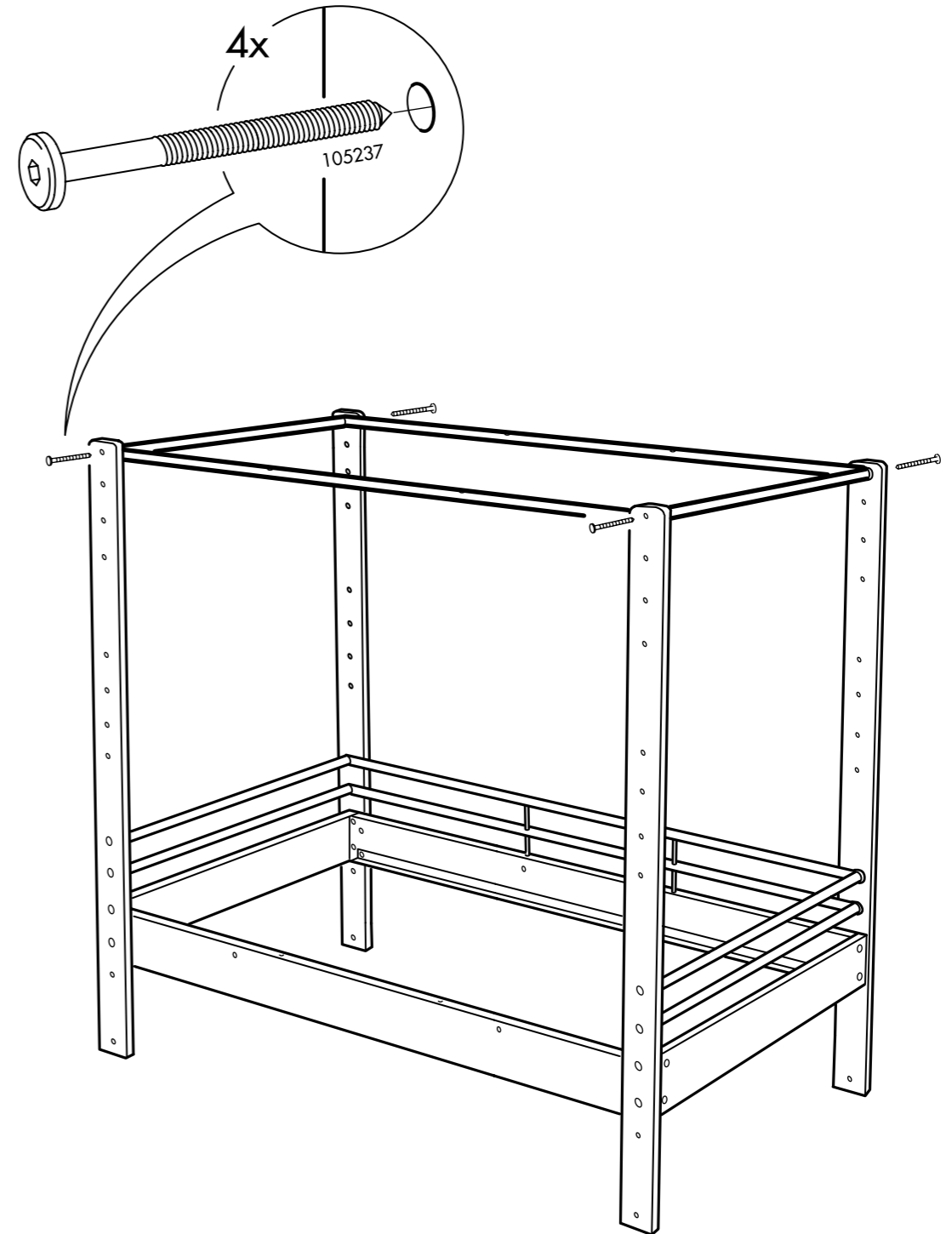

10

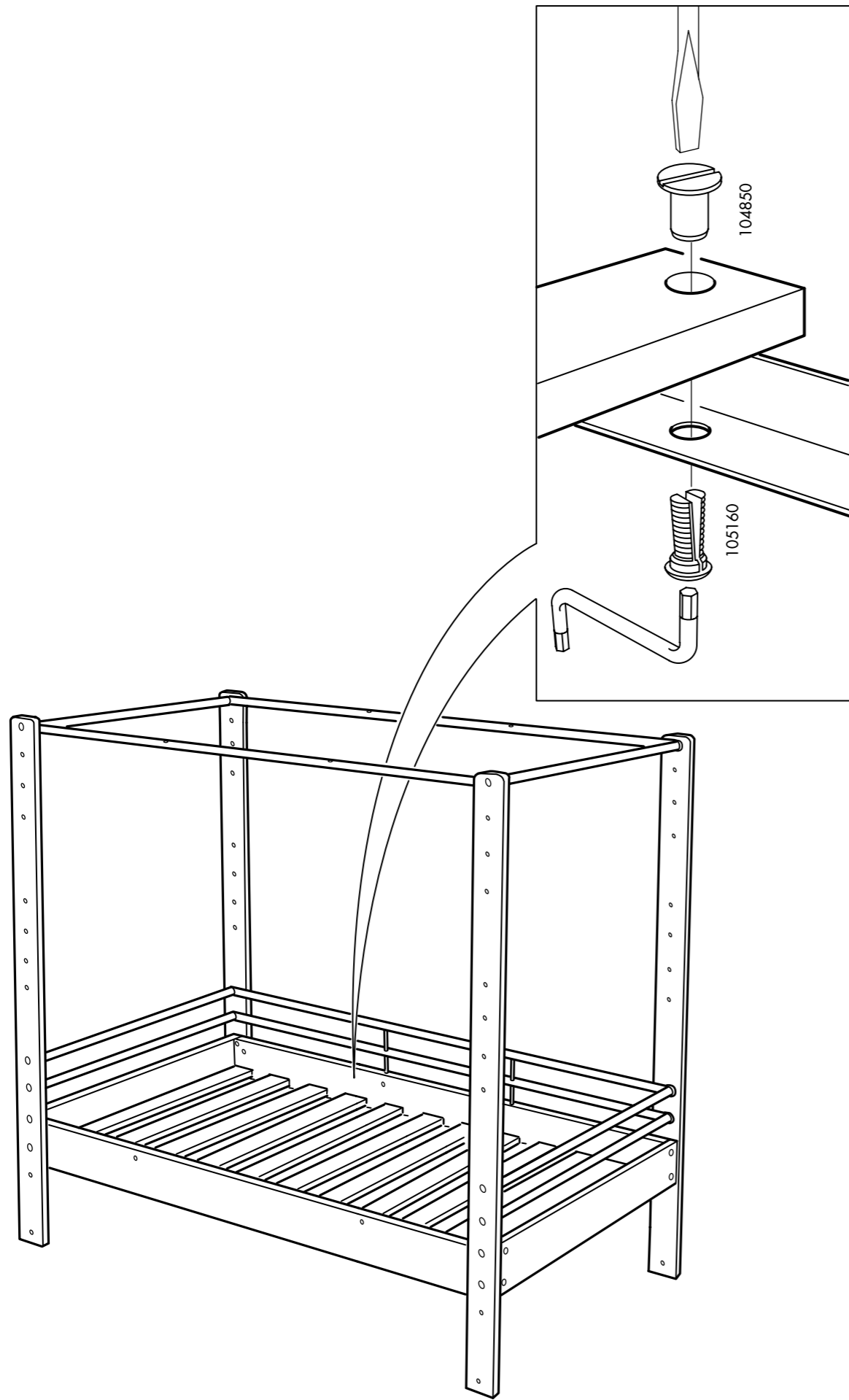

8

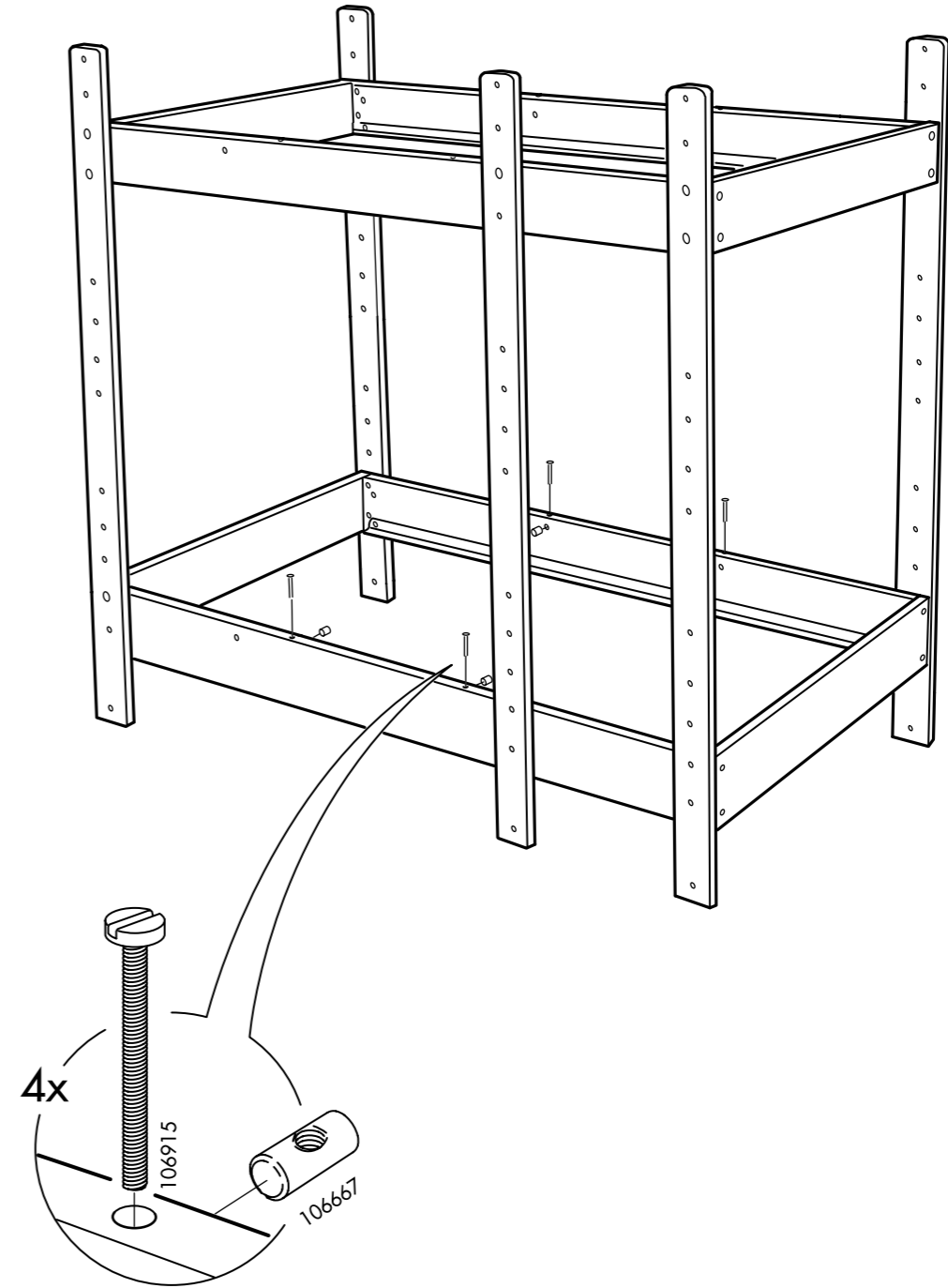

7

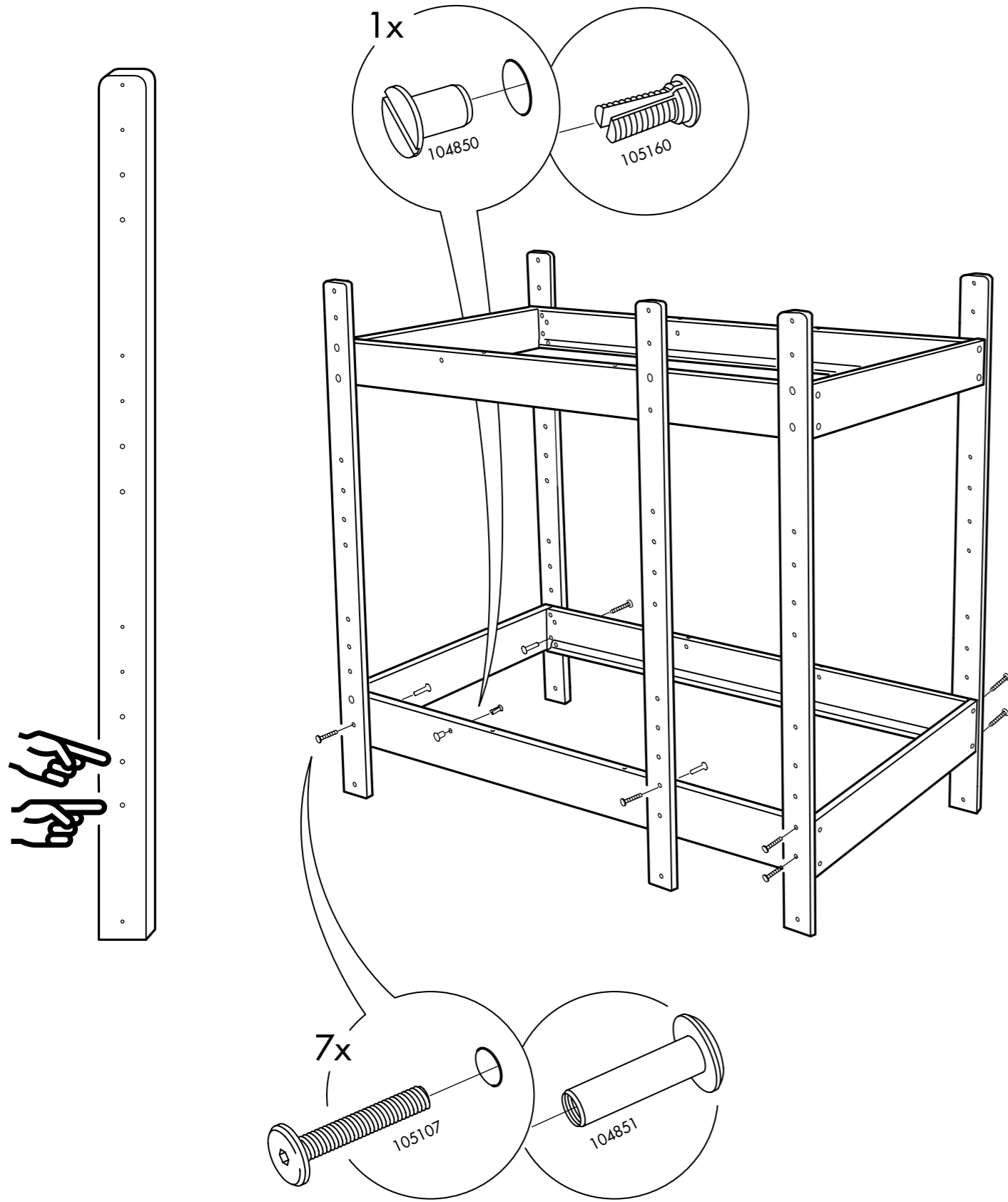

1

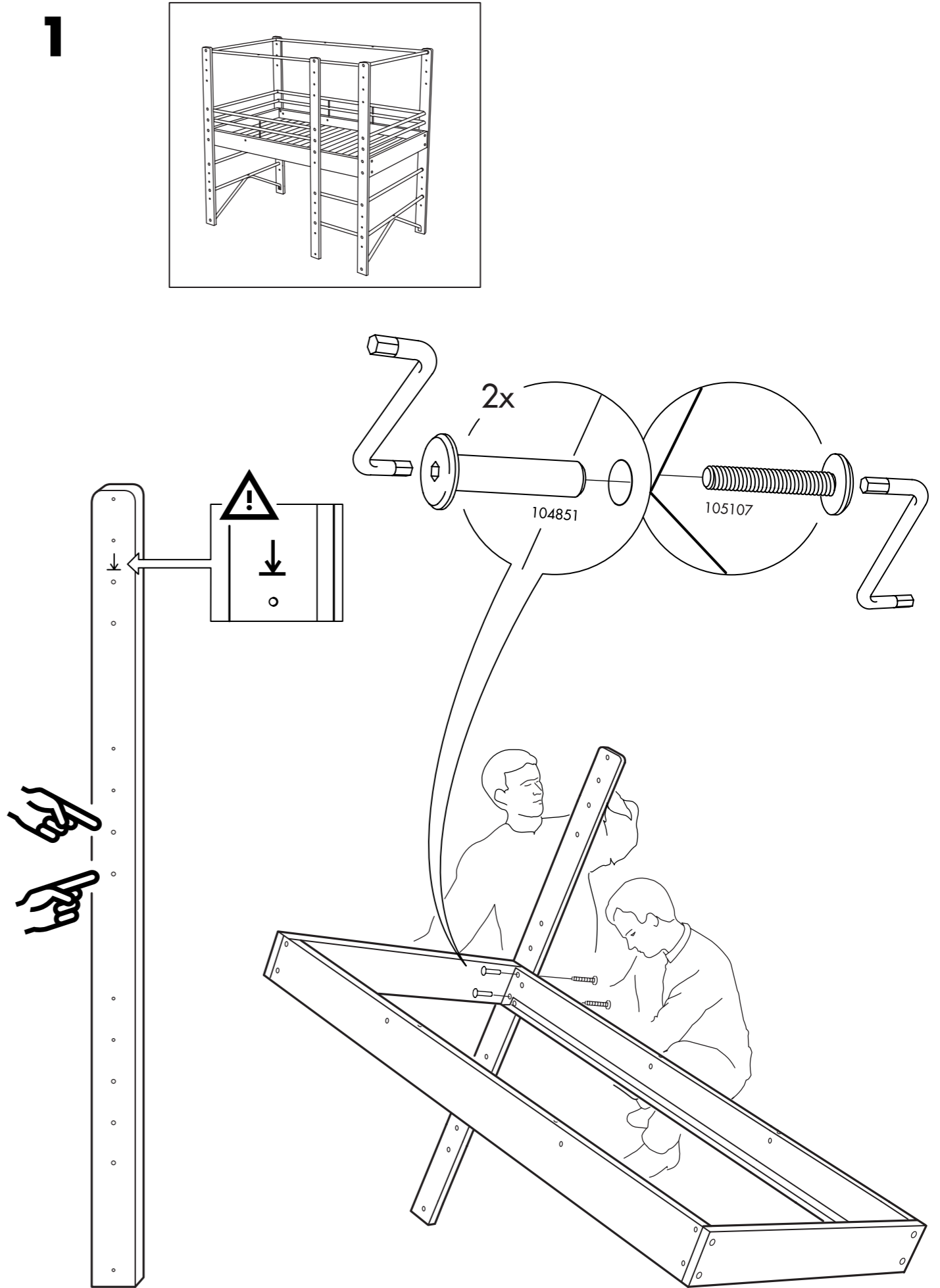

2

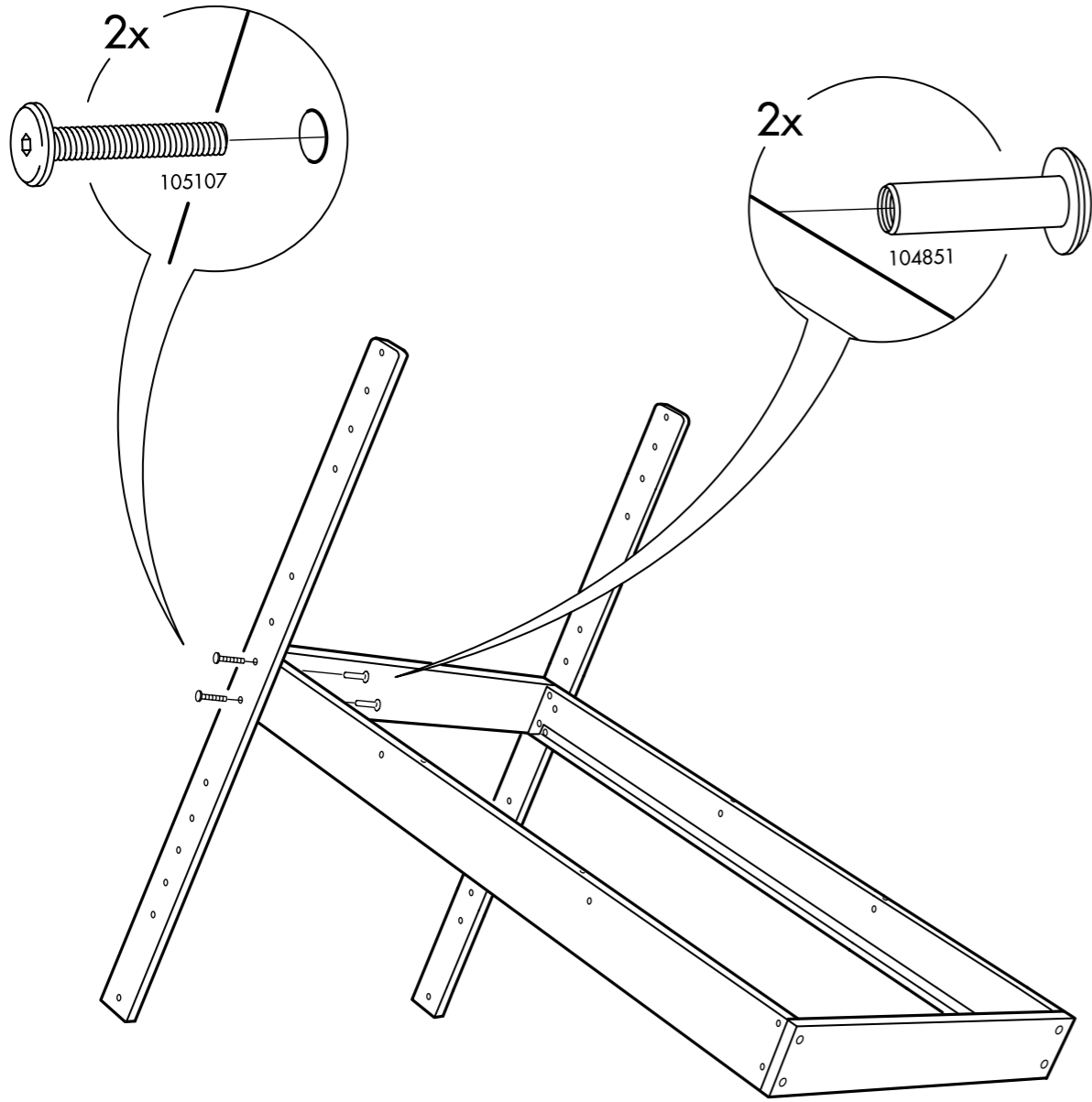

6

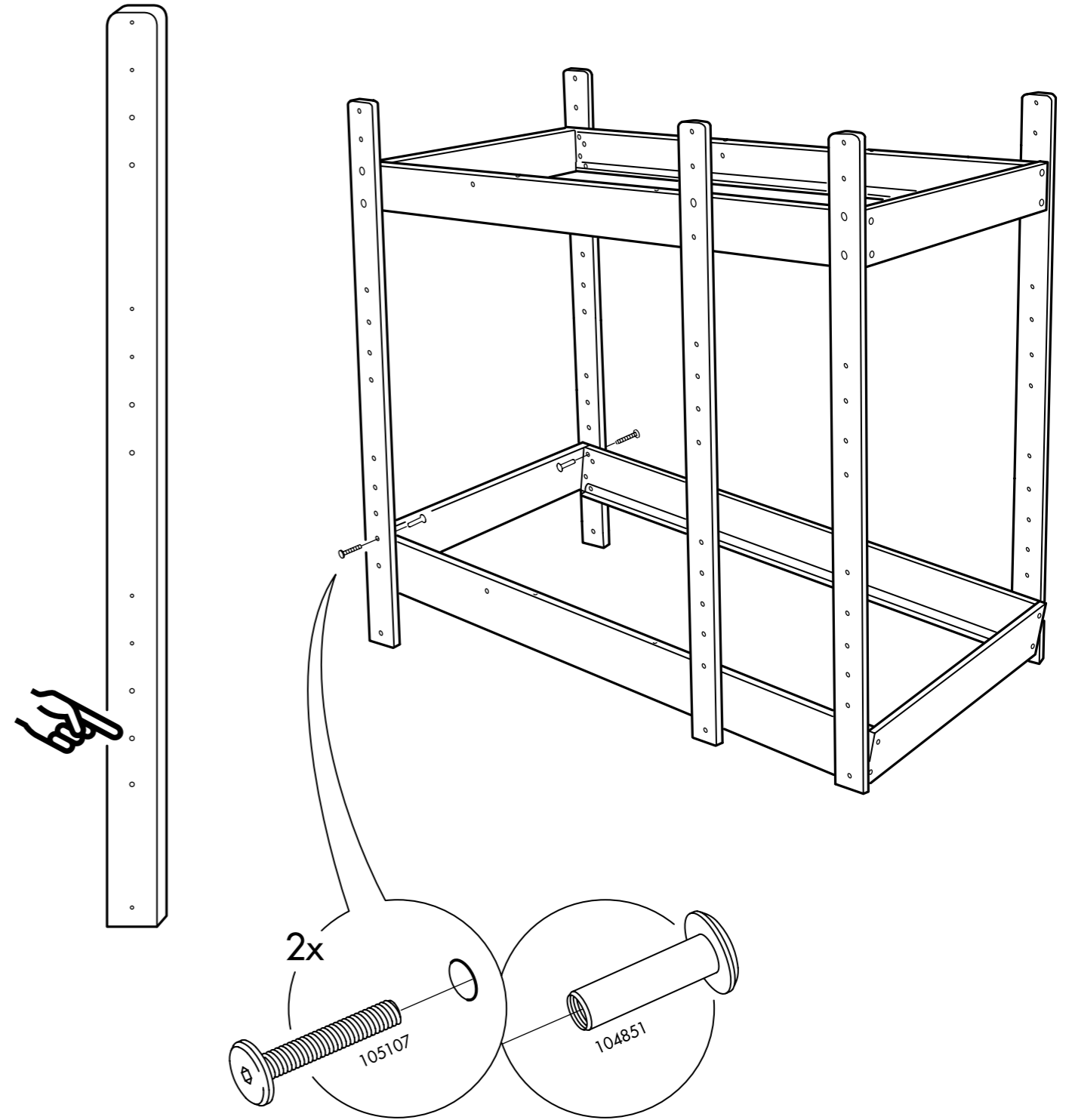

5

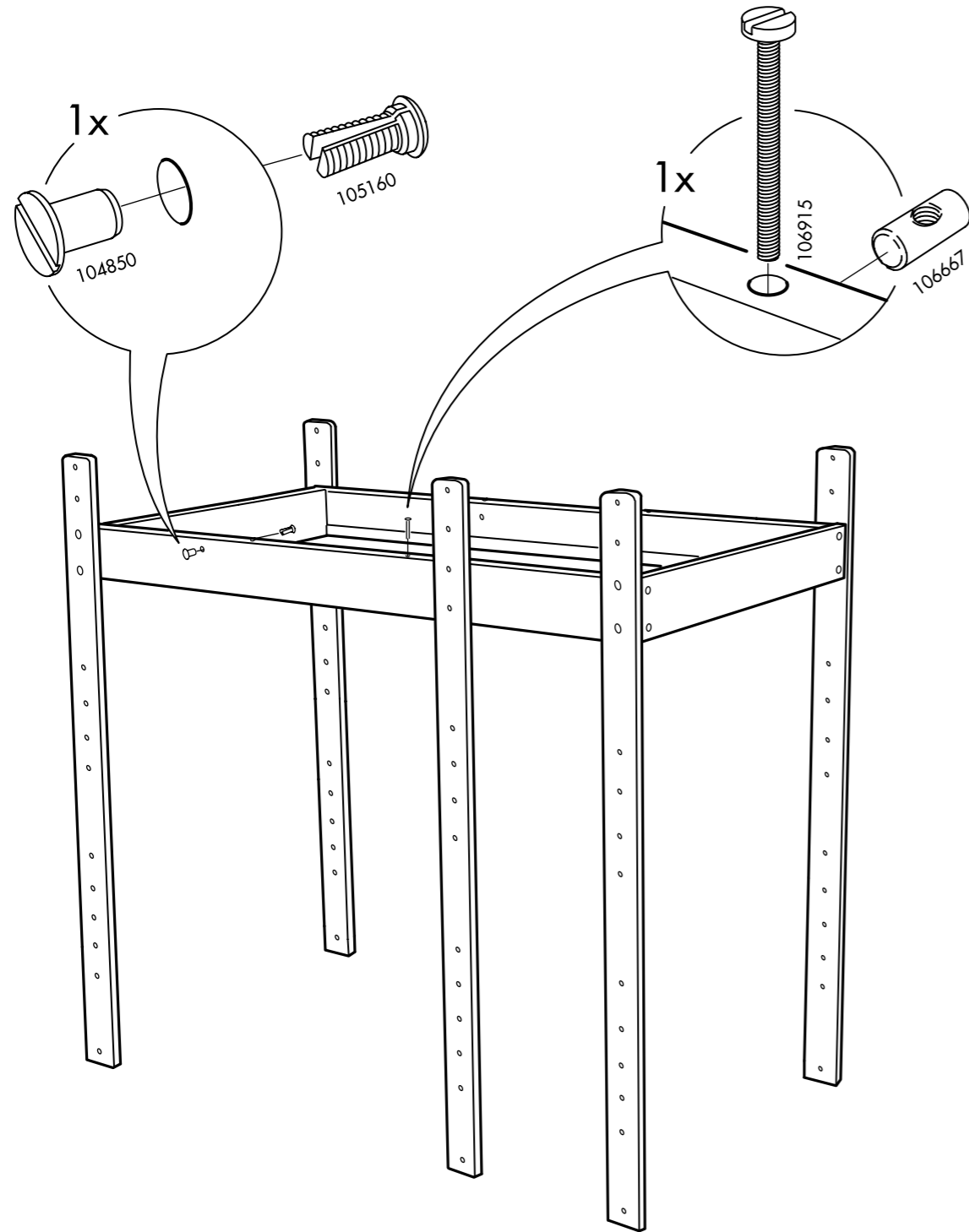

3

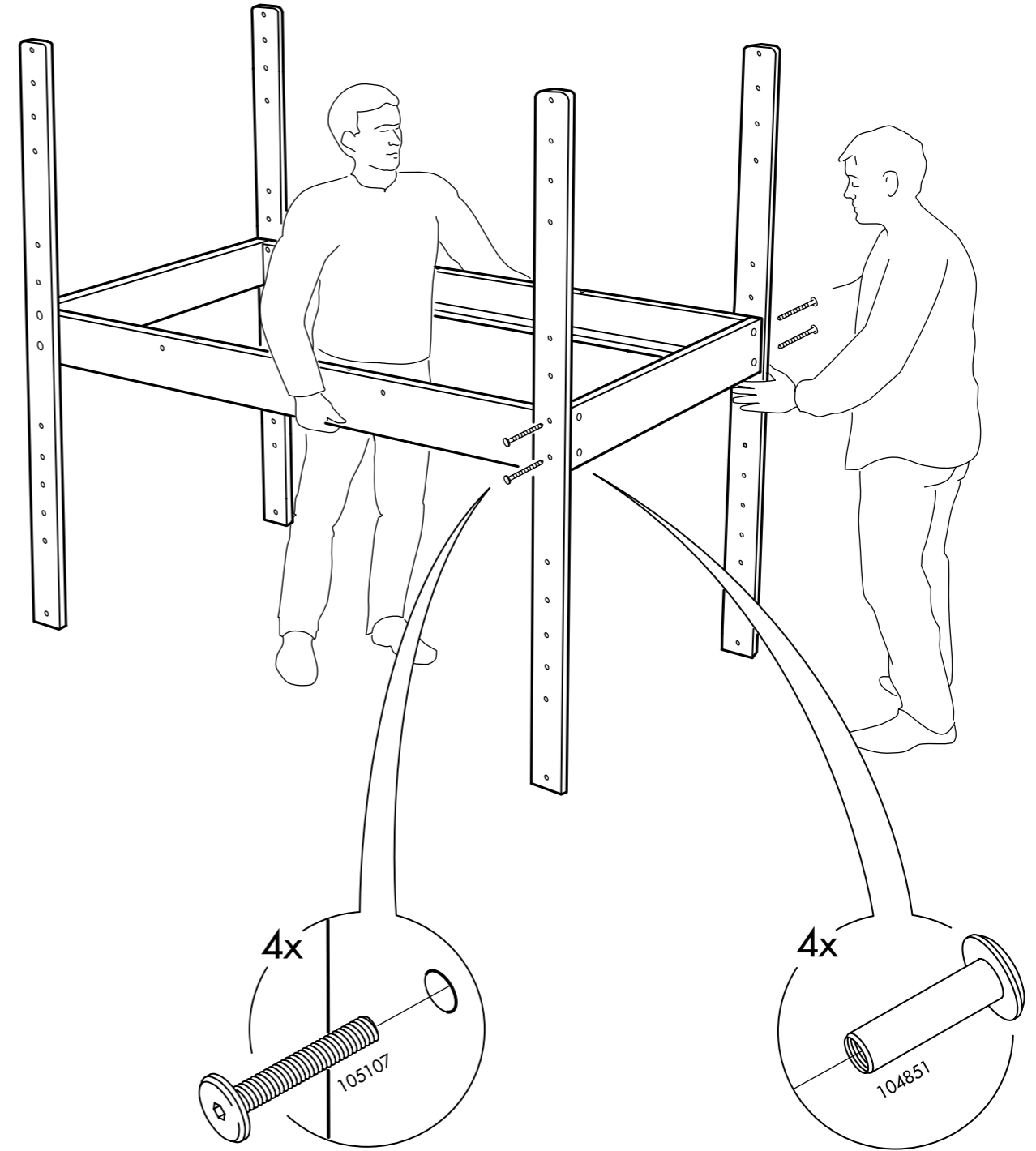

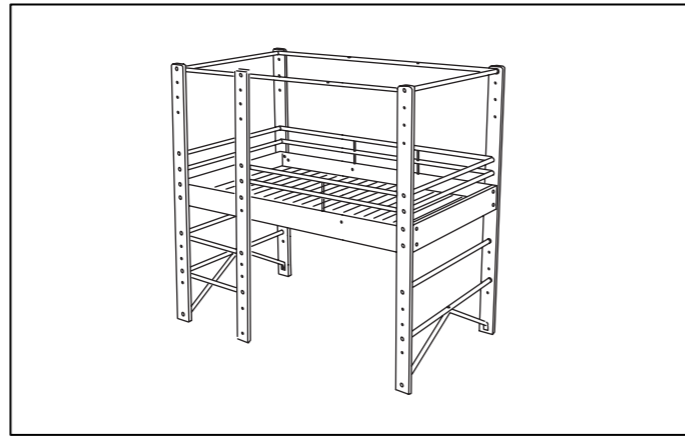
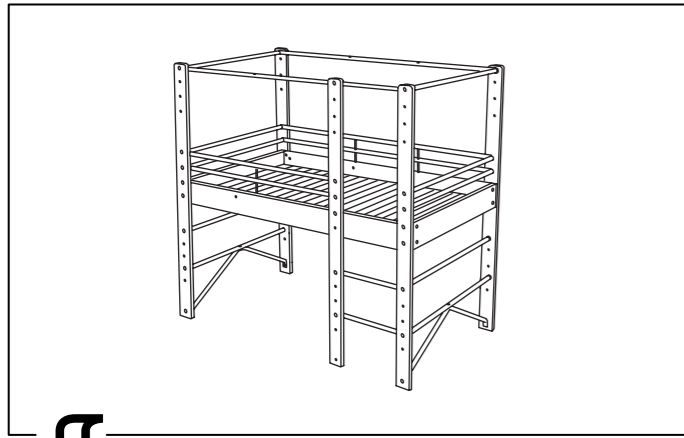

4



4

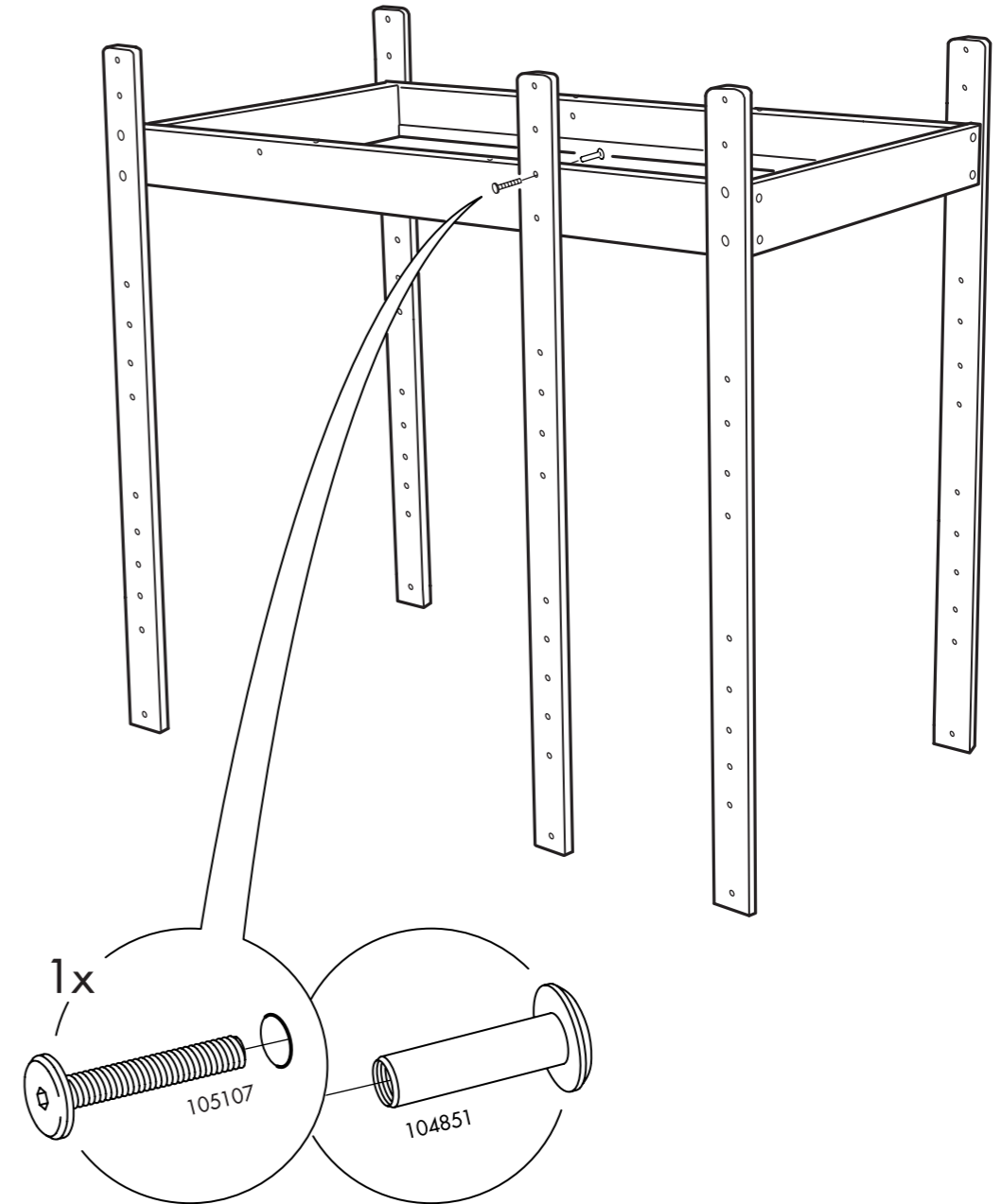
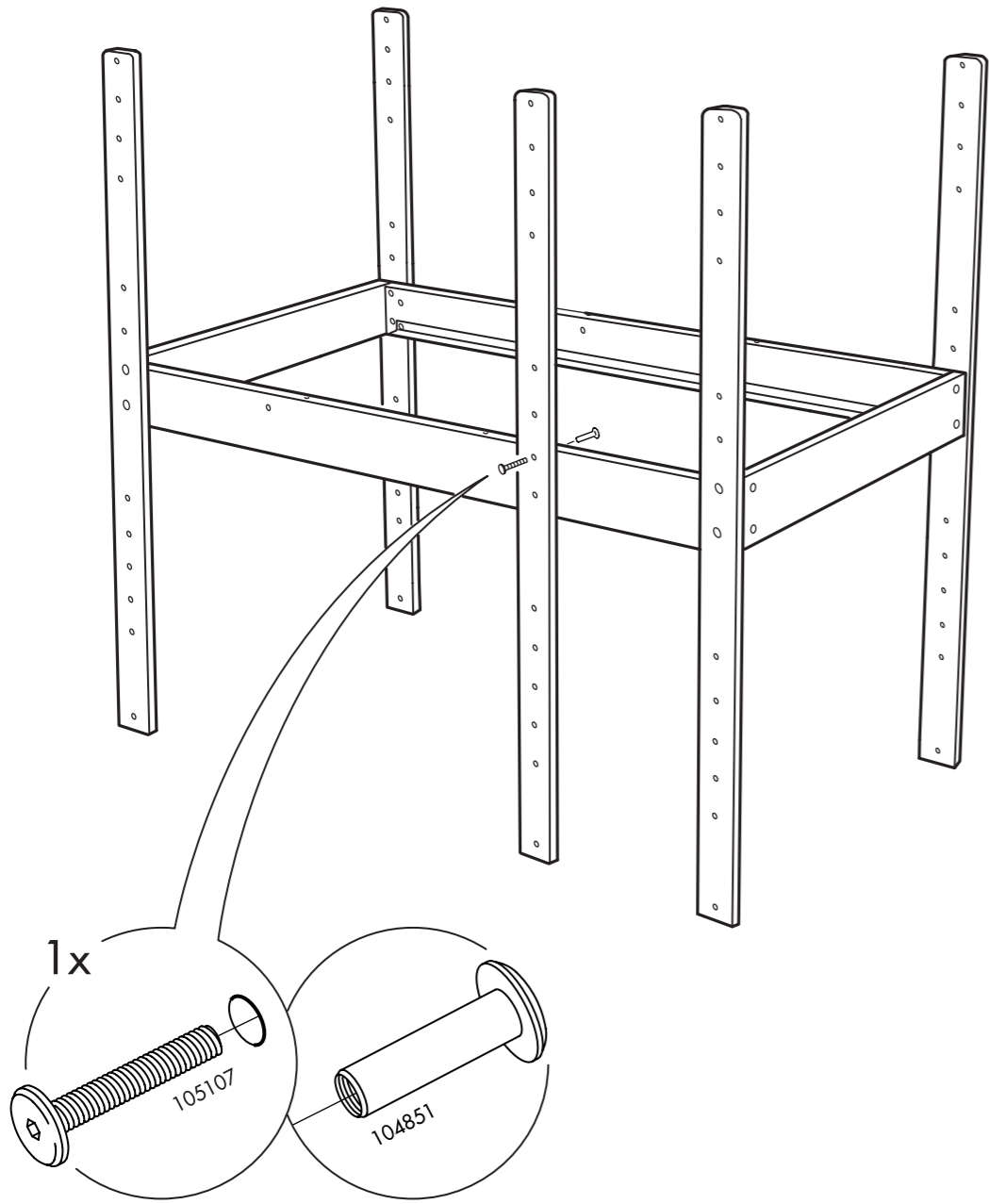

3

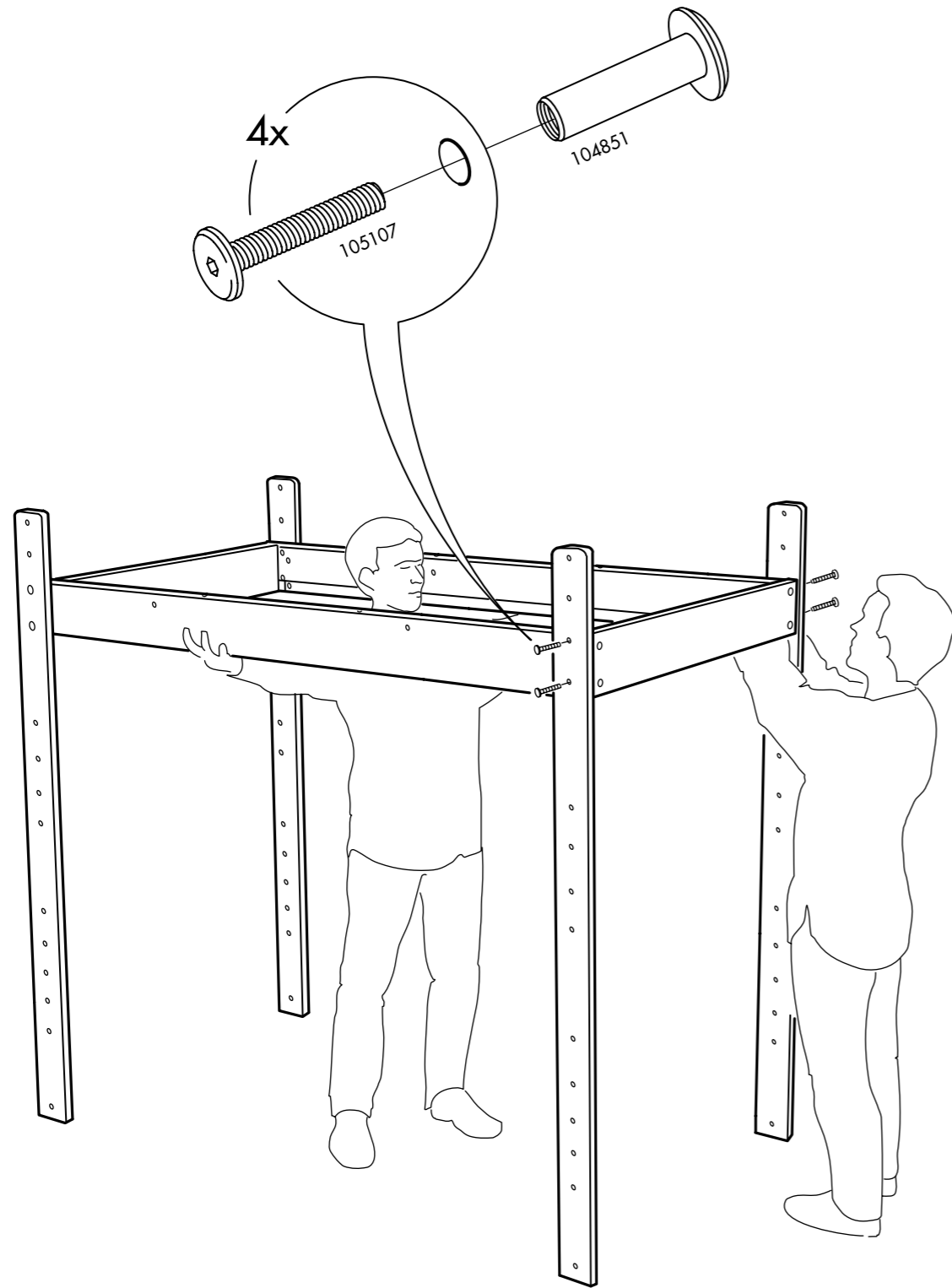

5

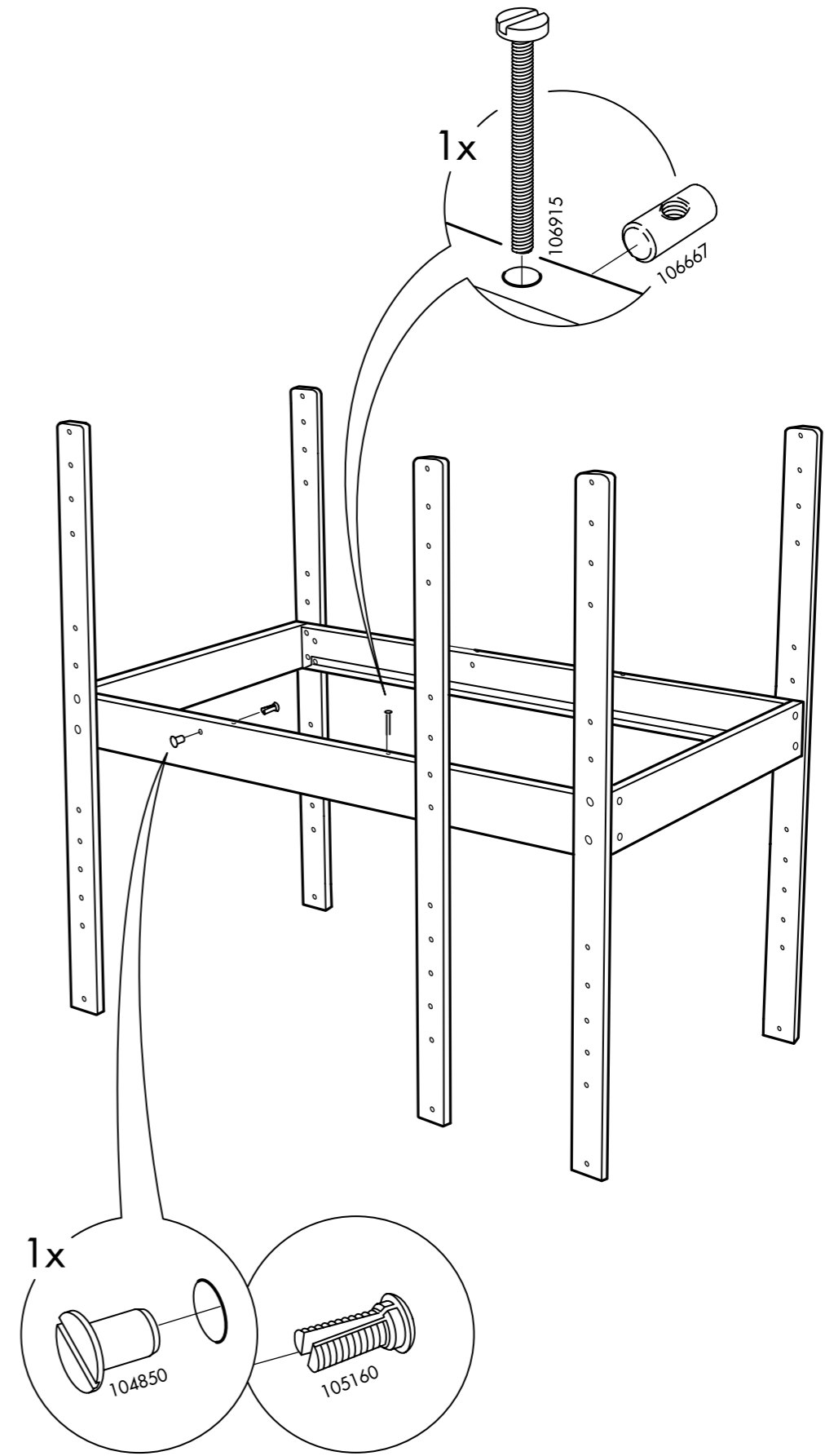

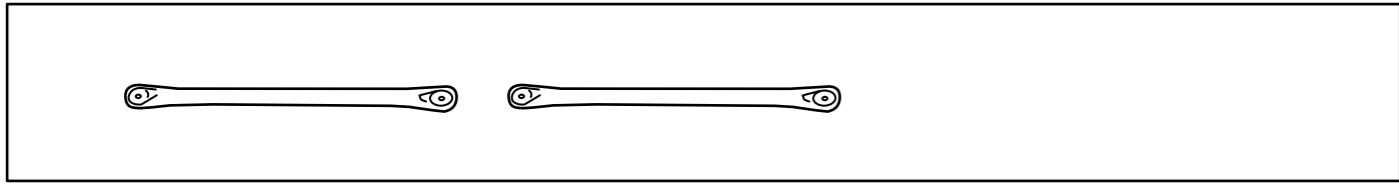

6

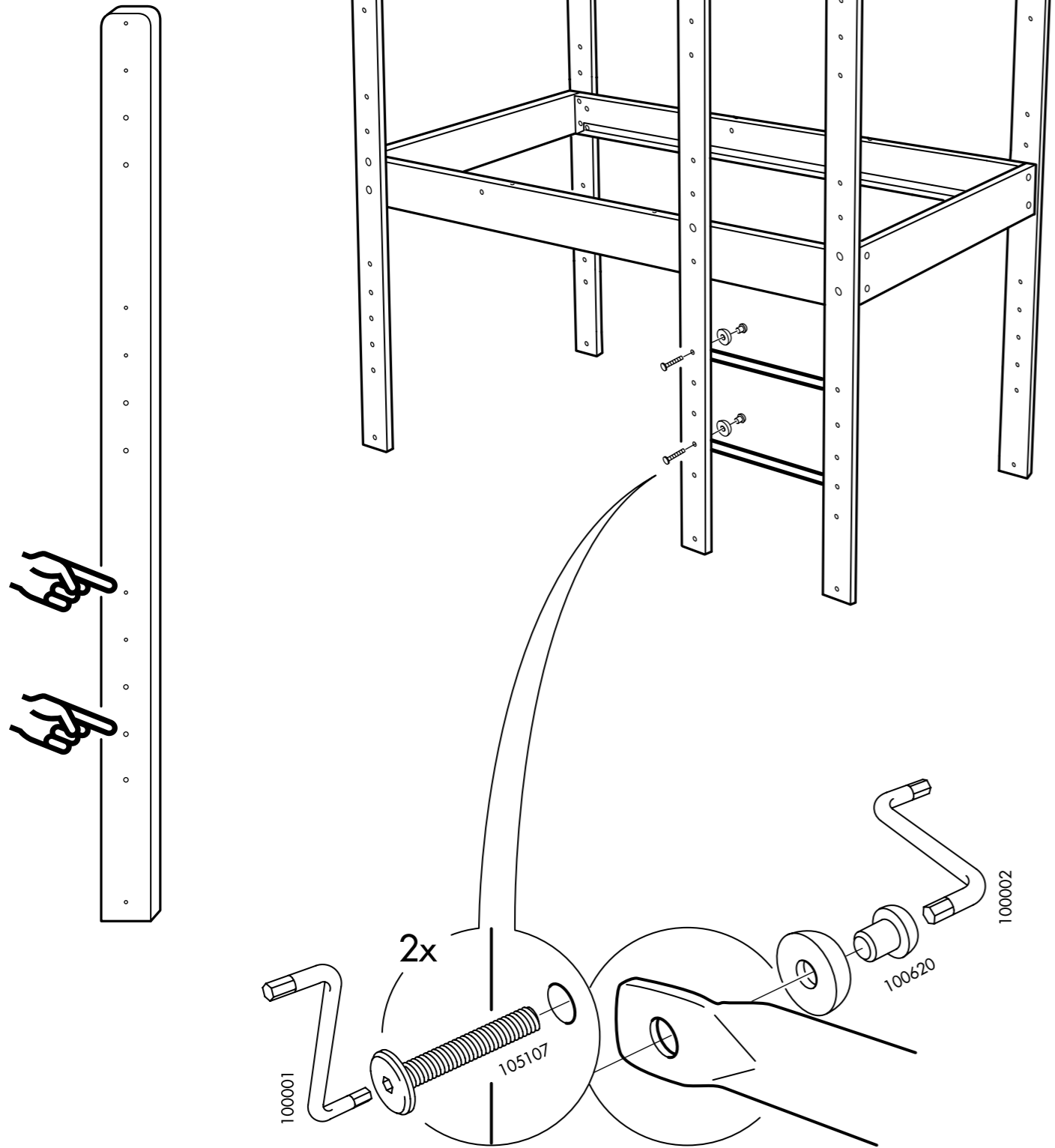

2

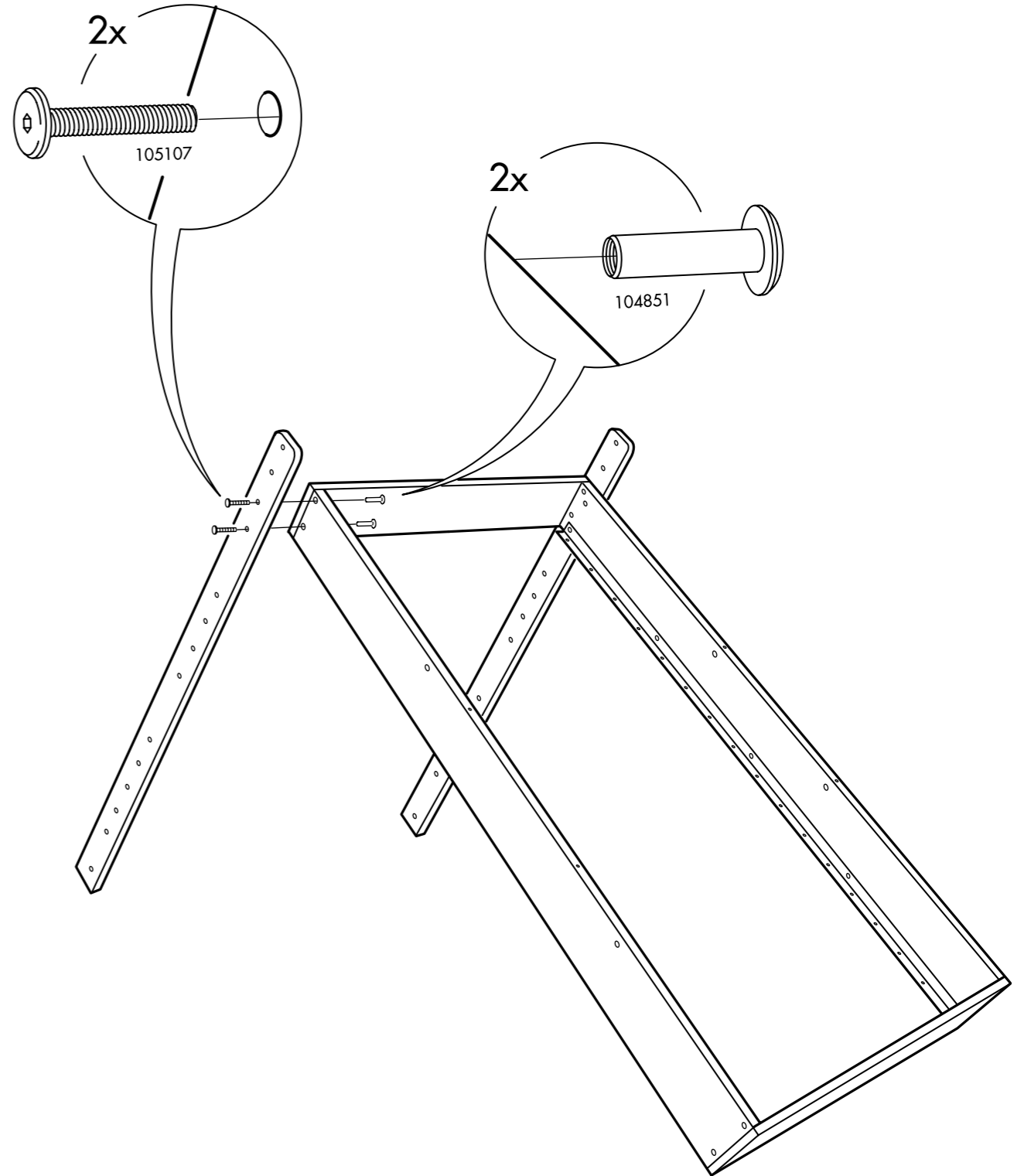

1

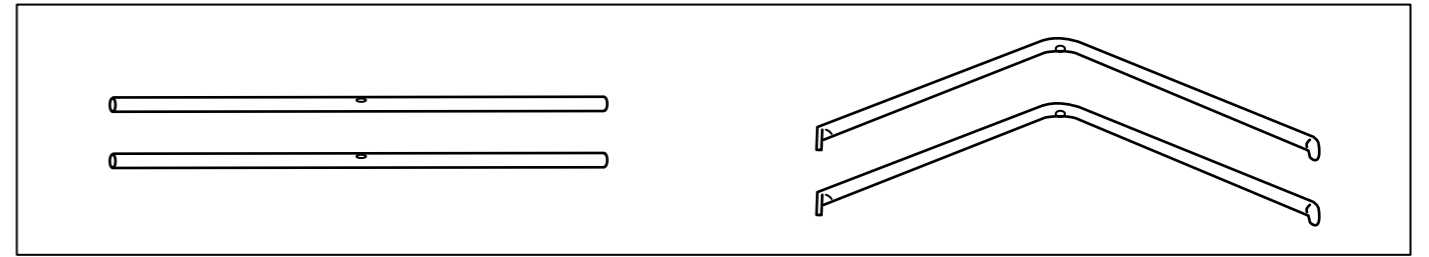
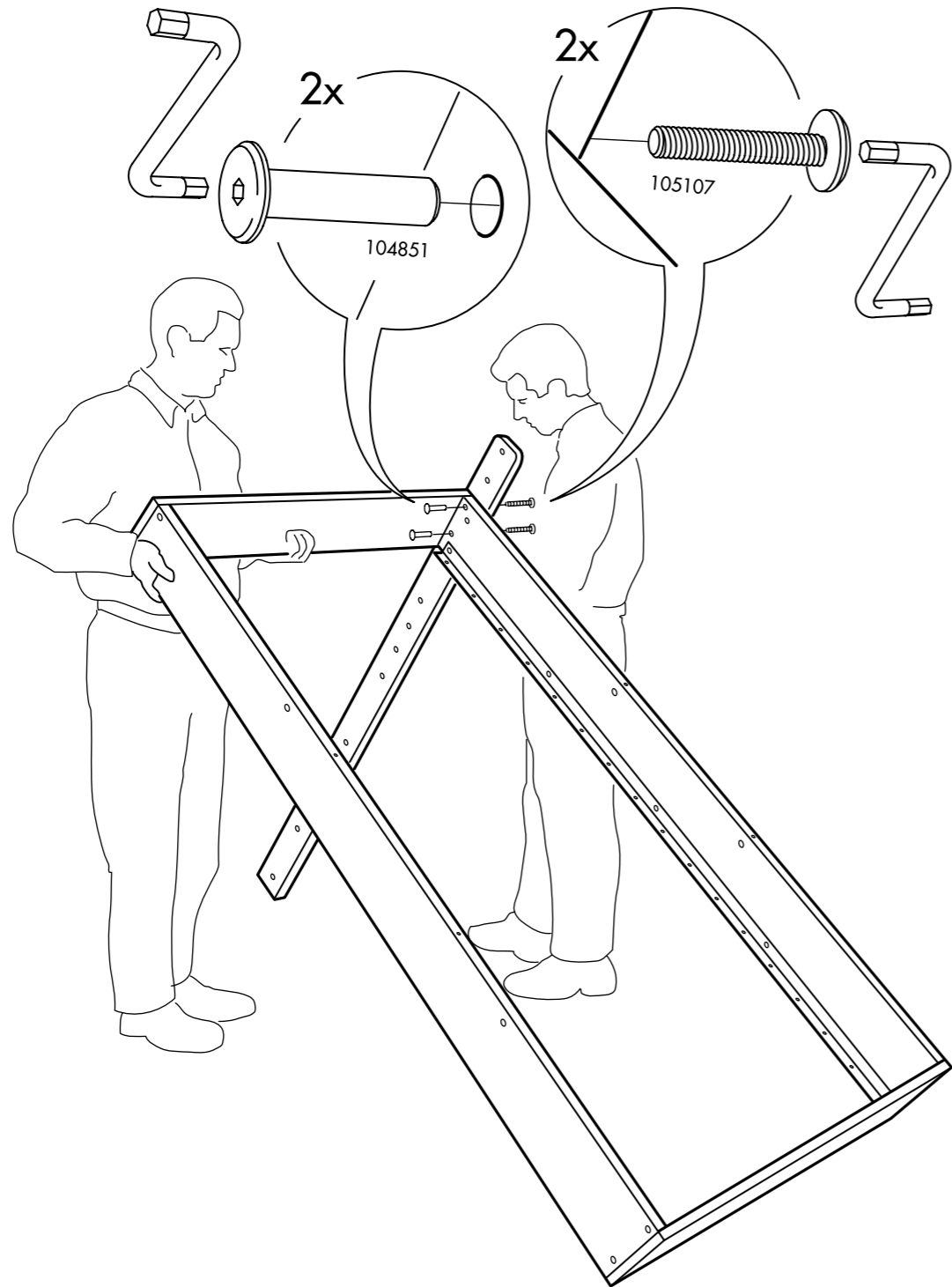
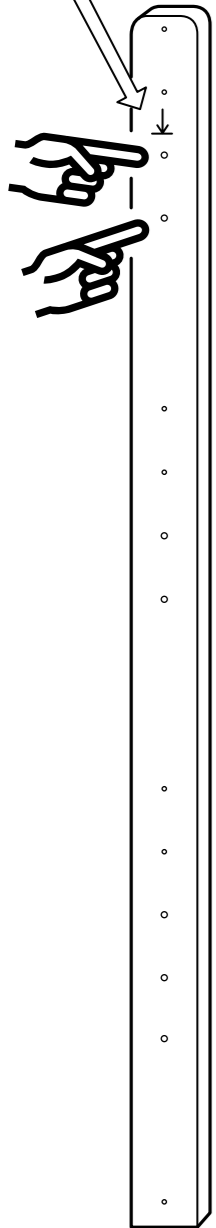
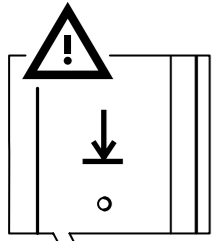

7

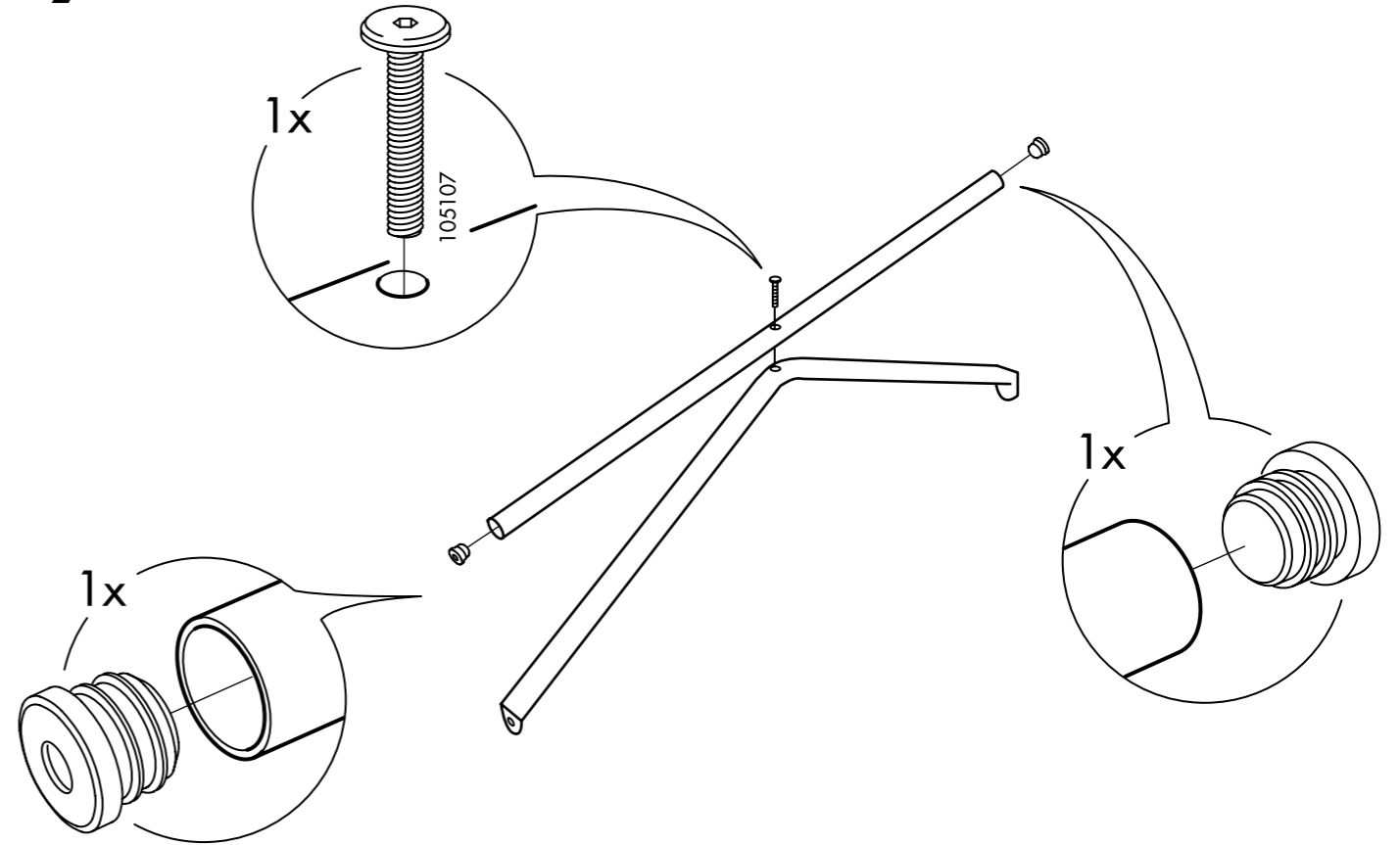

8

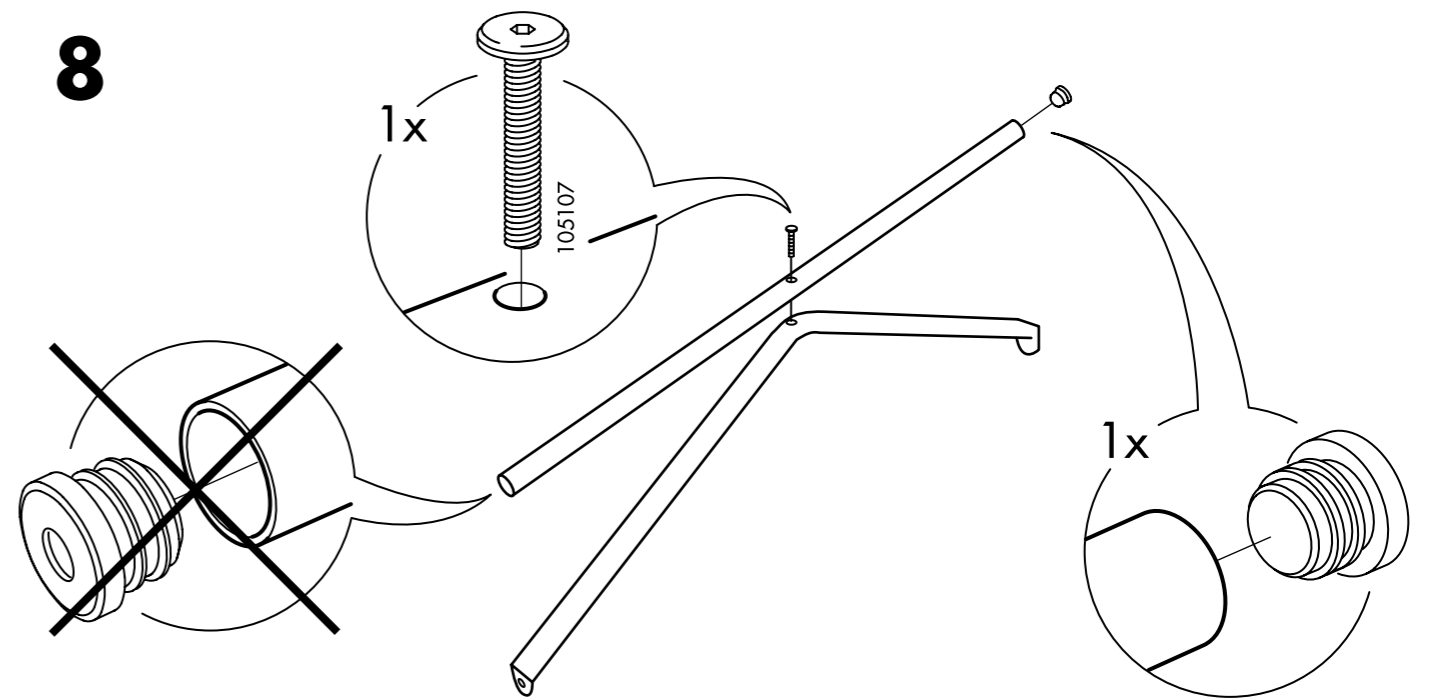

9

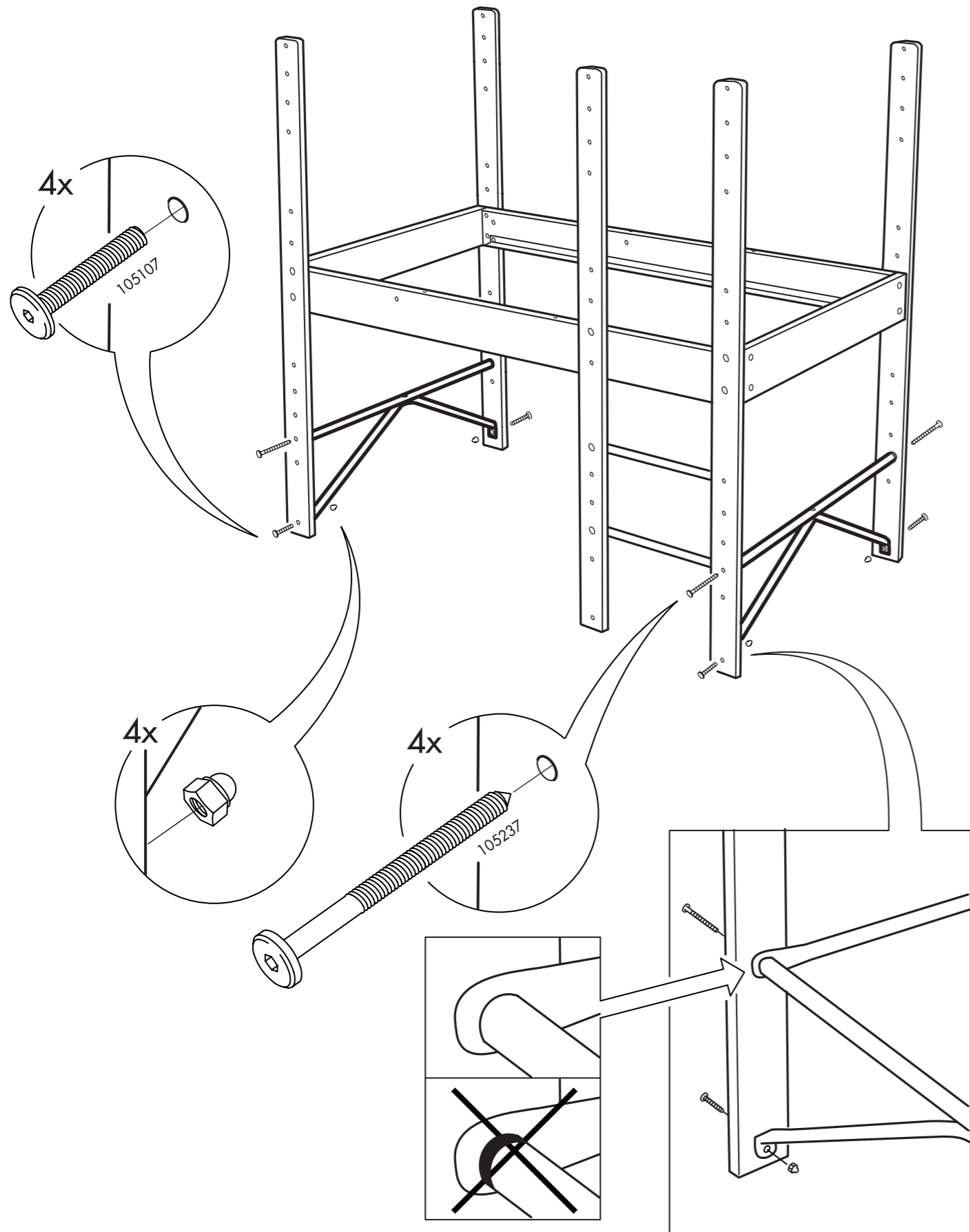

23

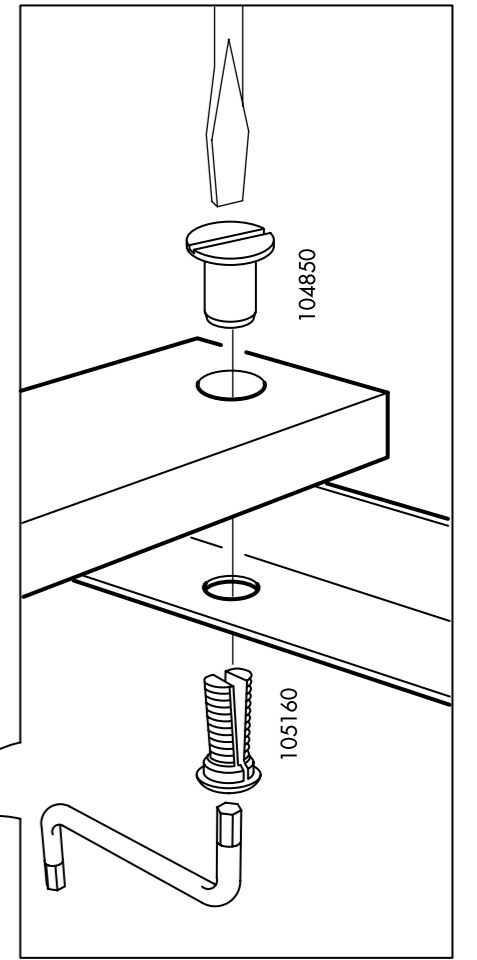

22

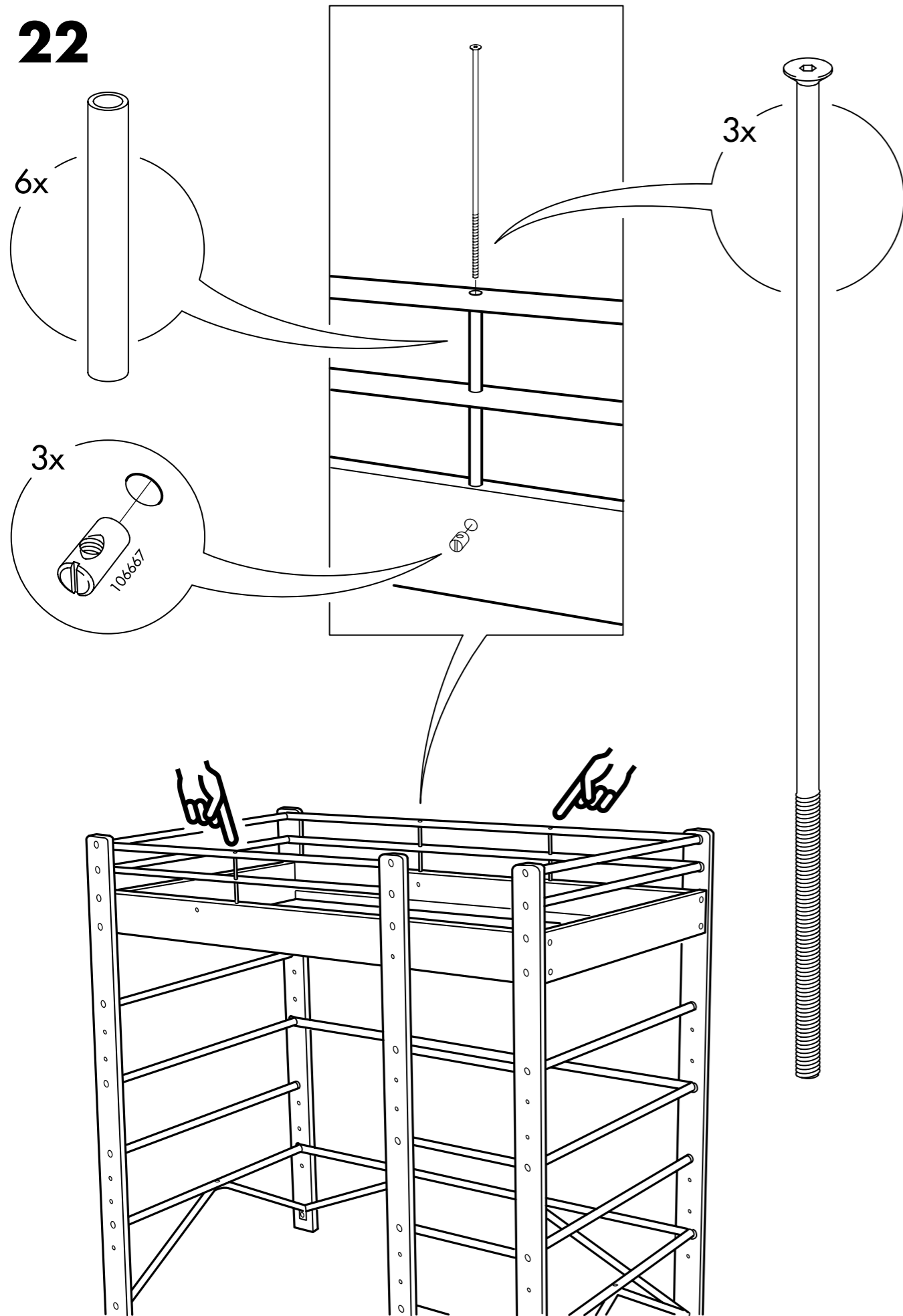

10

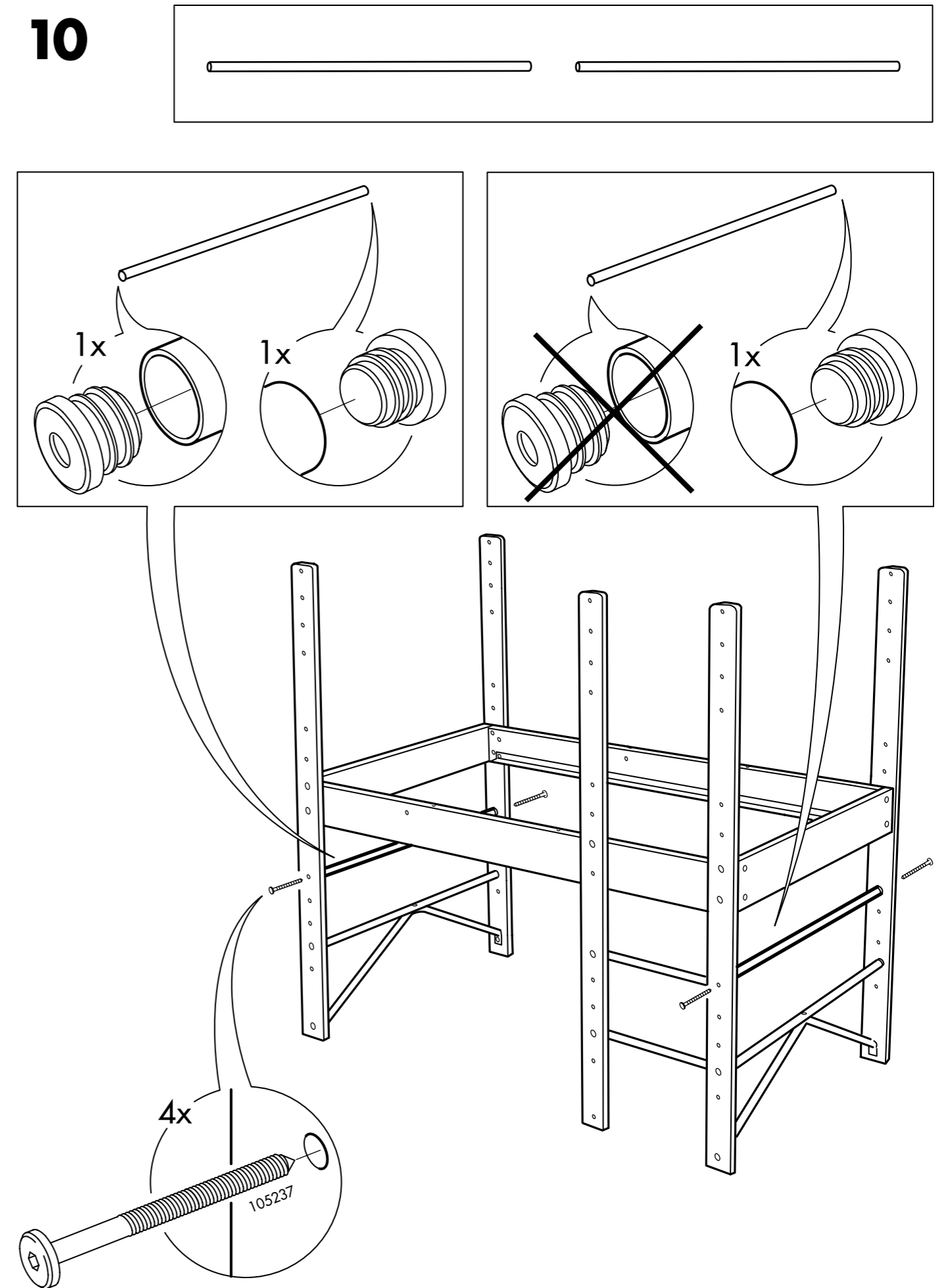

11

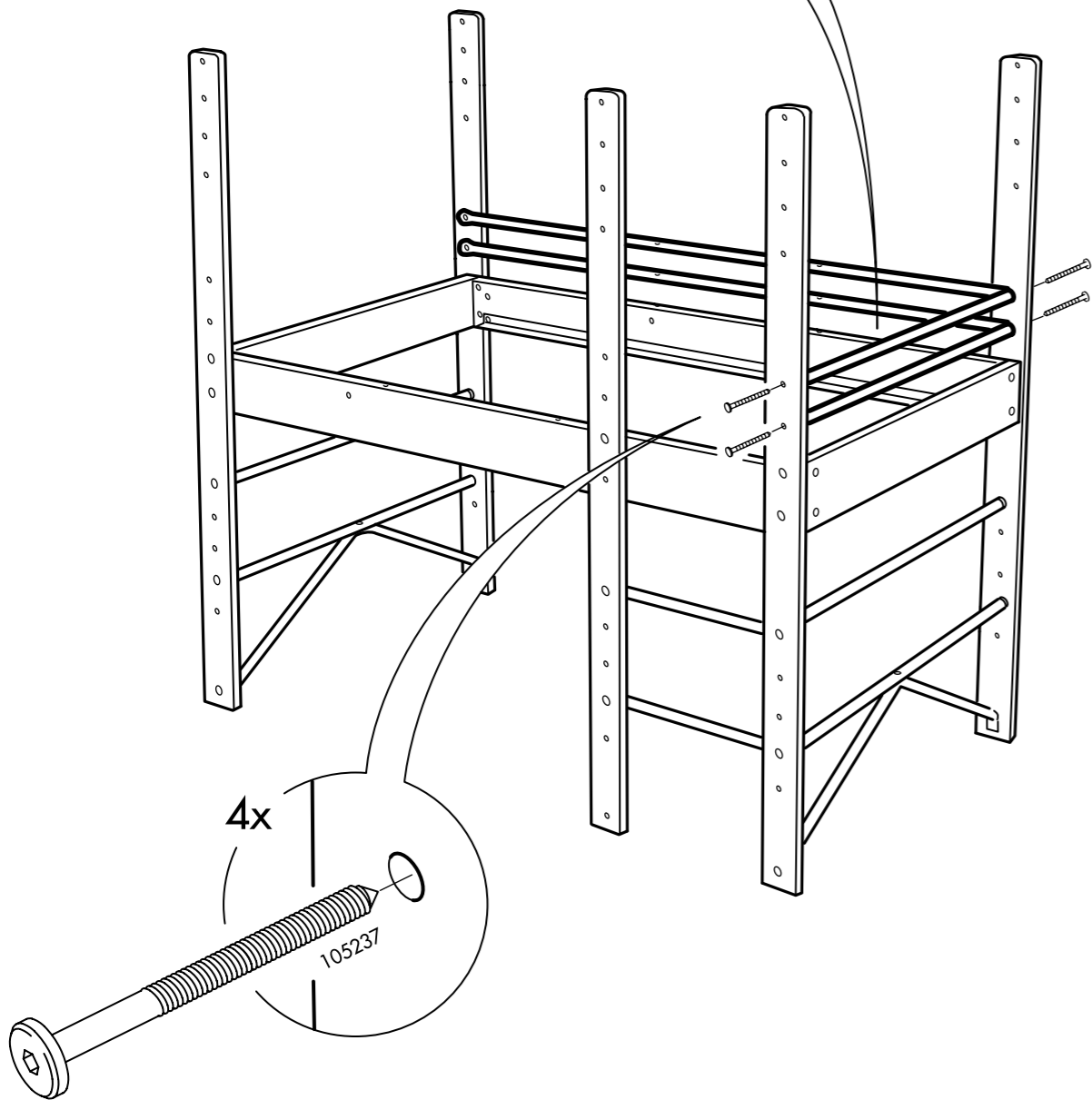
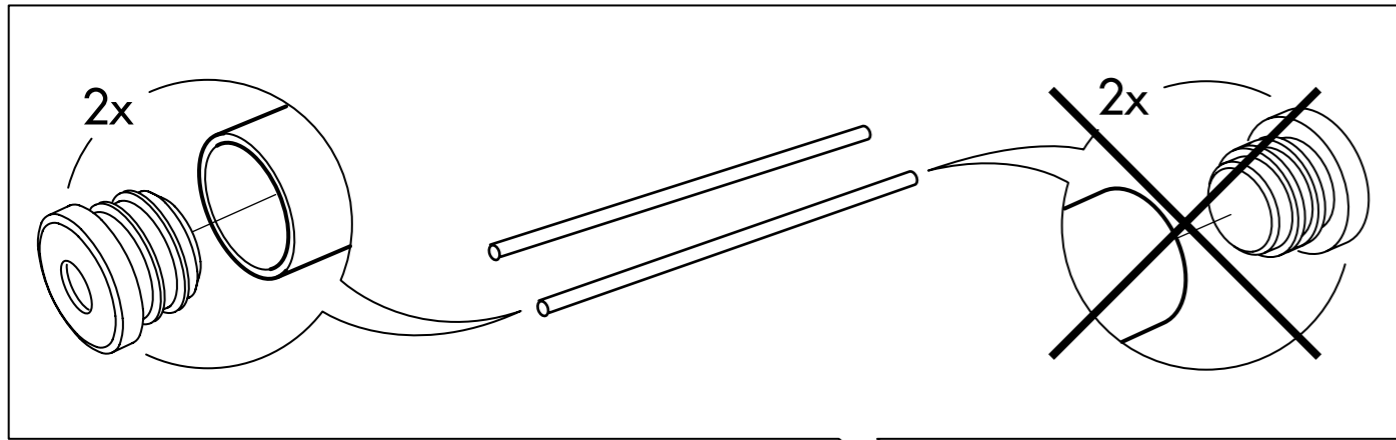

21

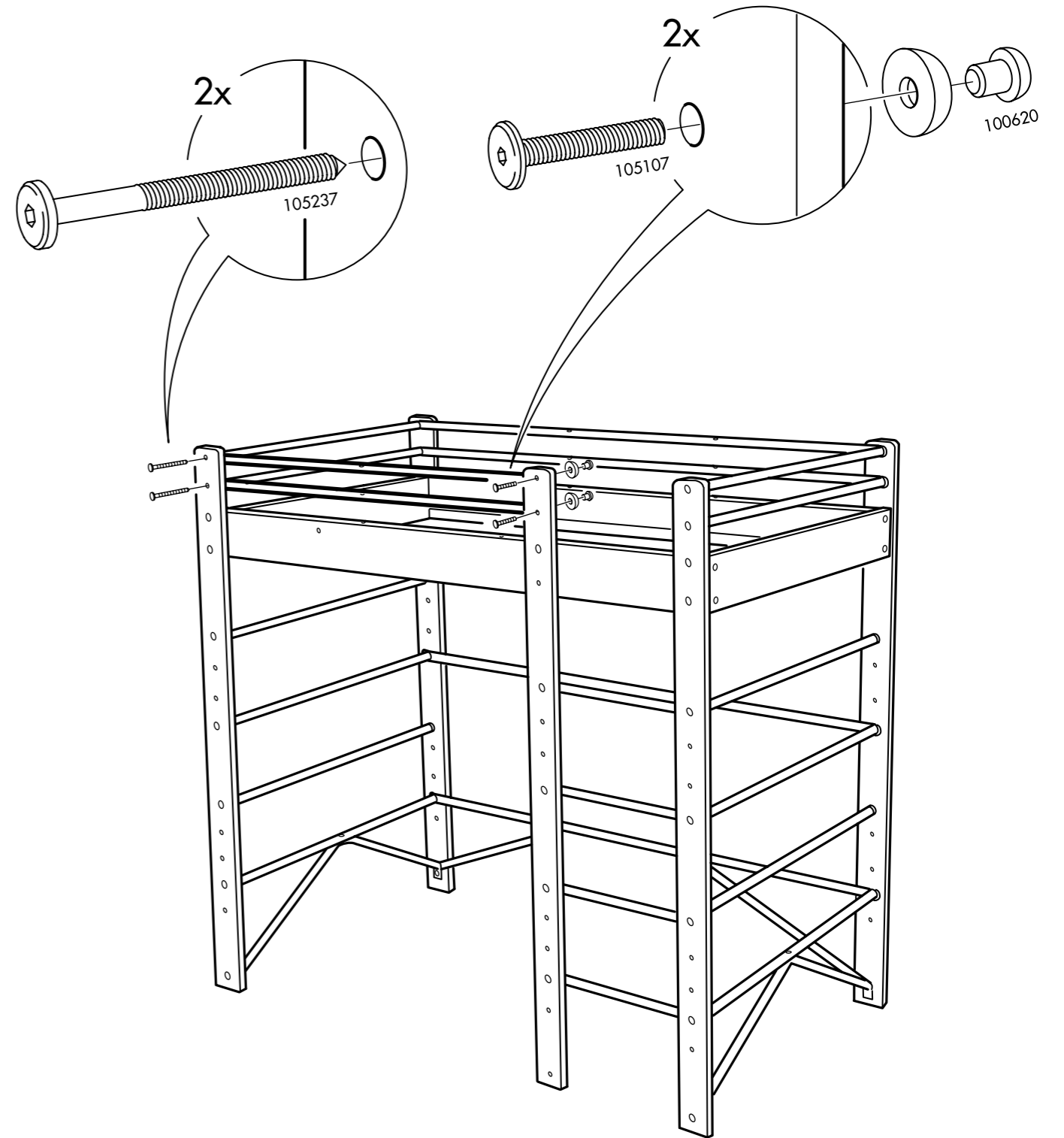
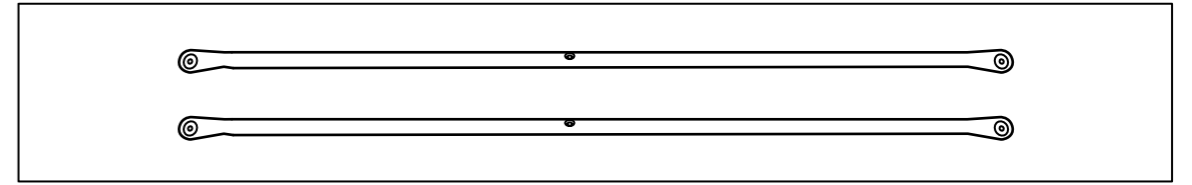

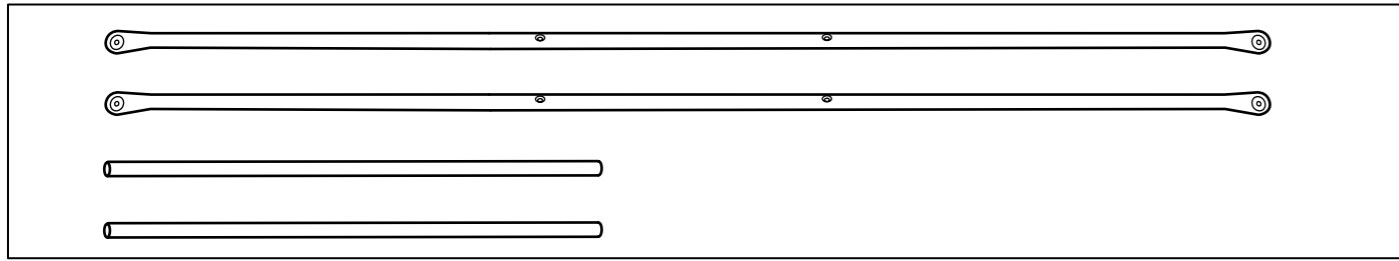

20

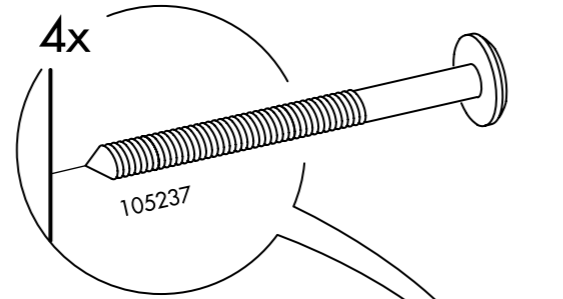

12

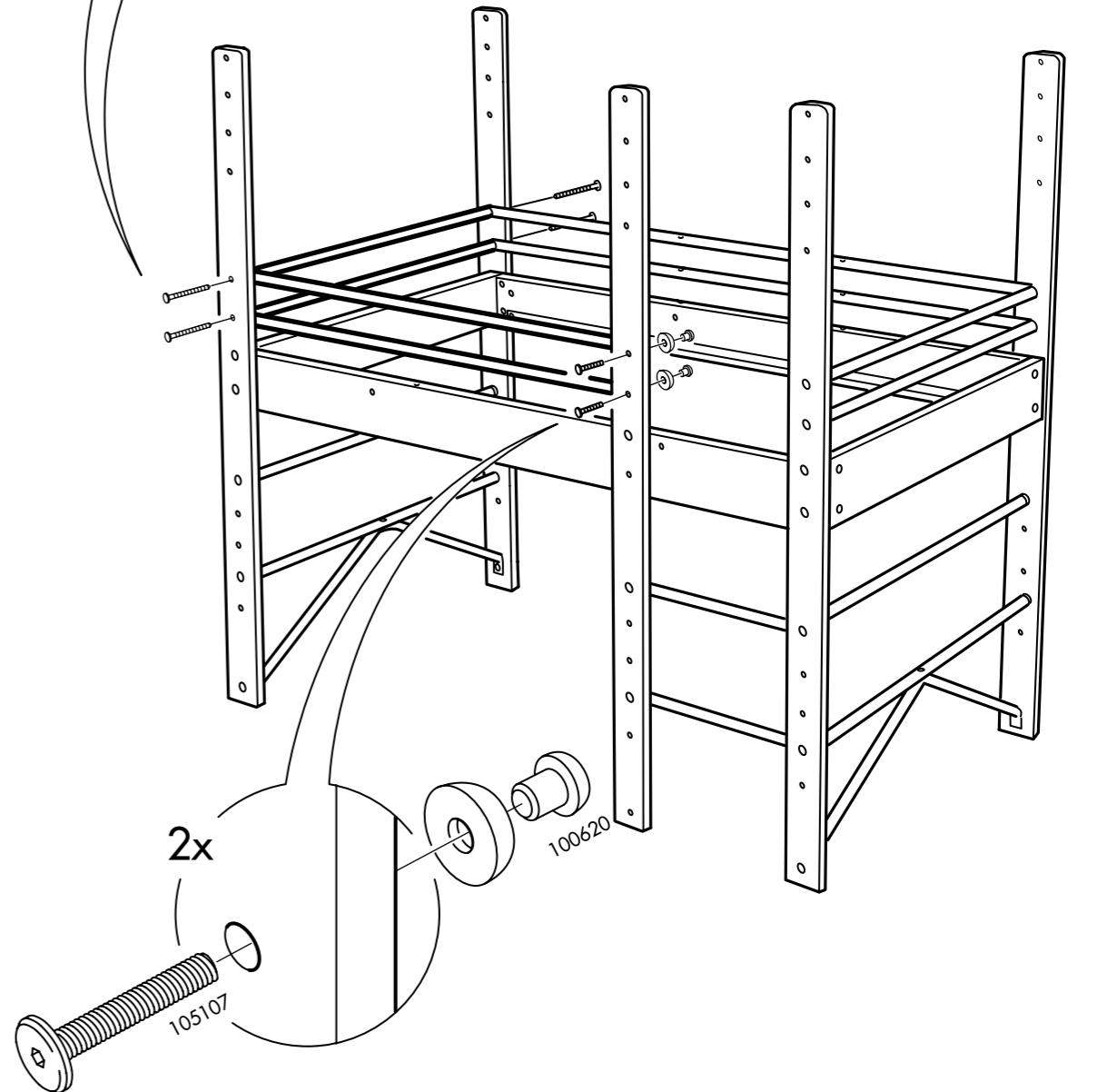
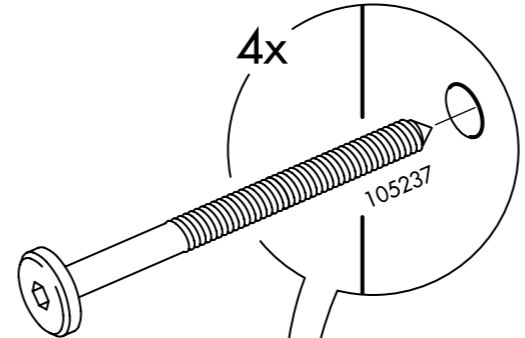
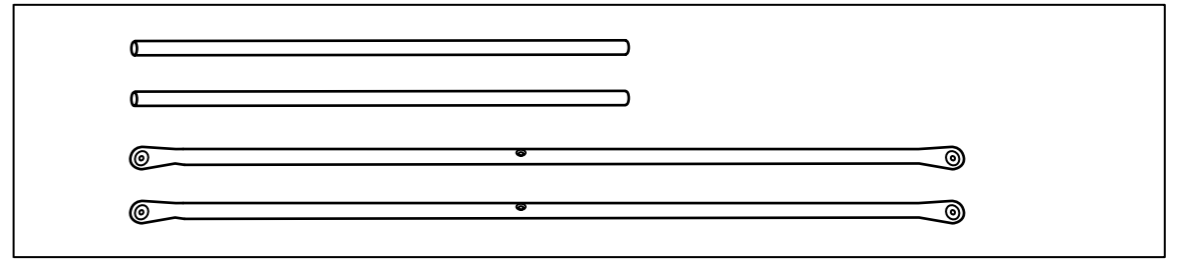

13

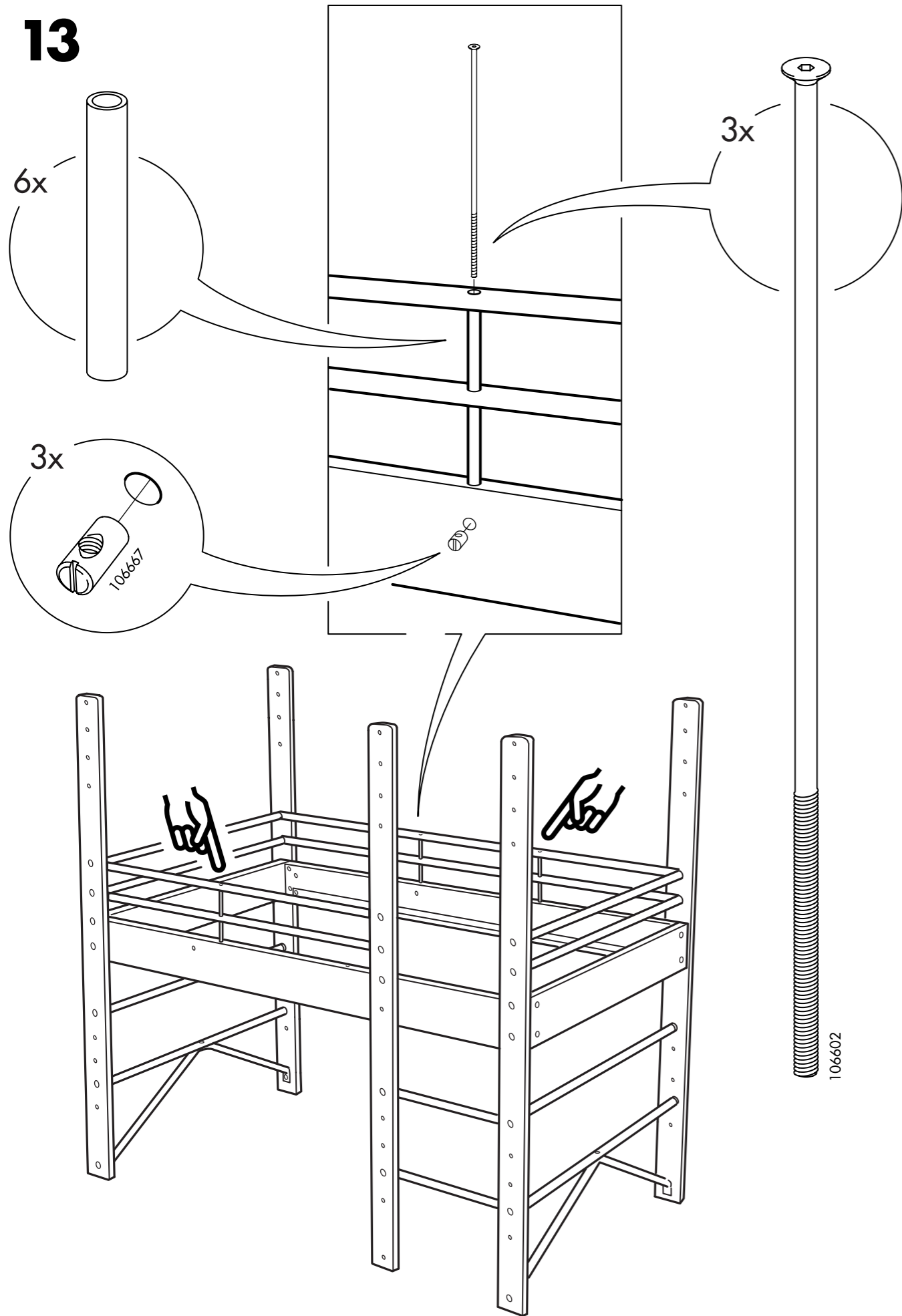

19

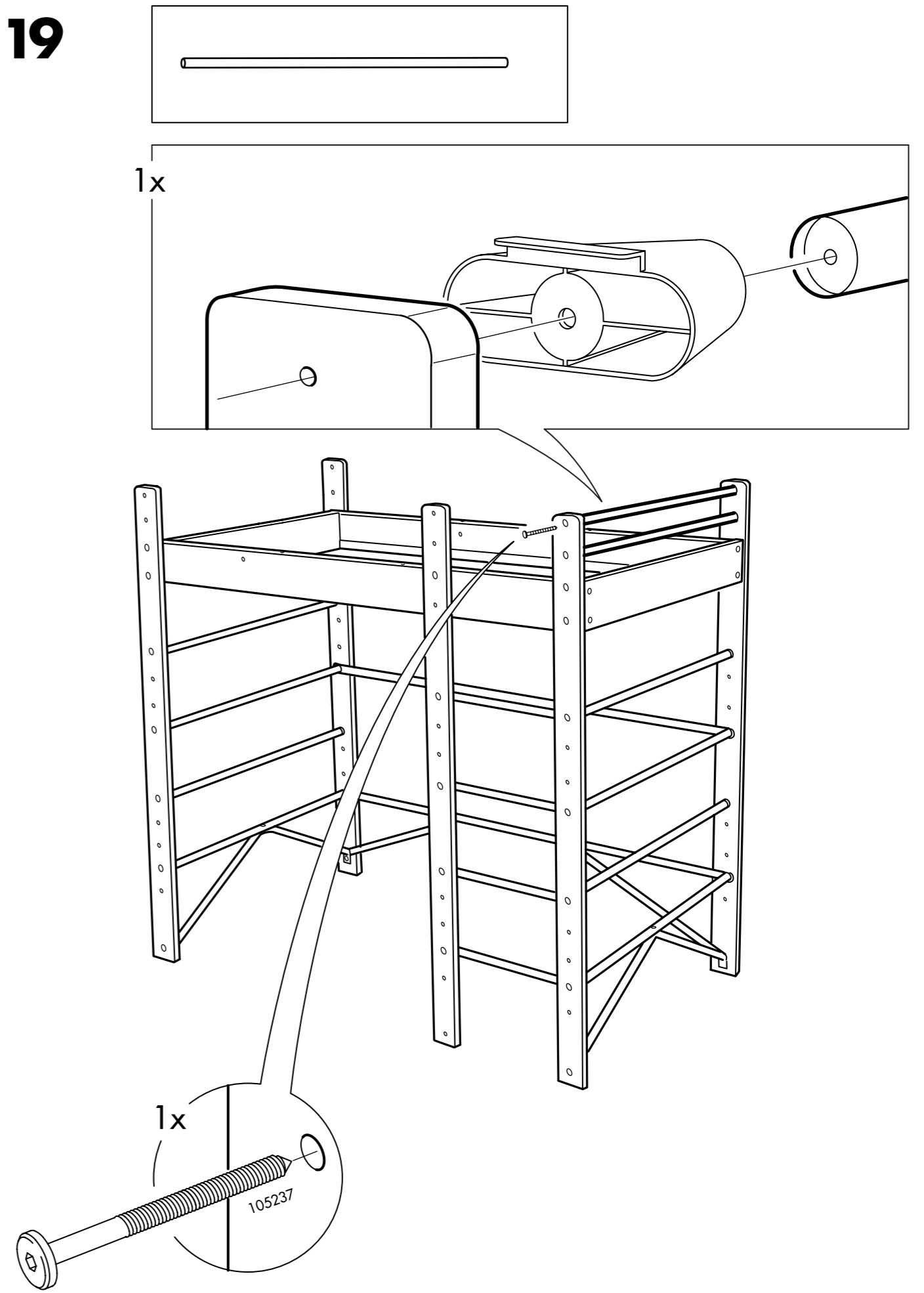

18

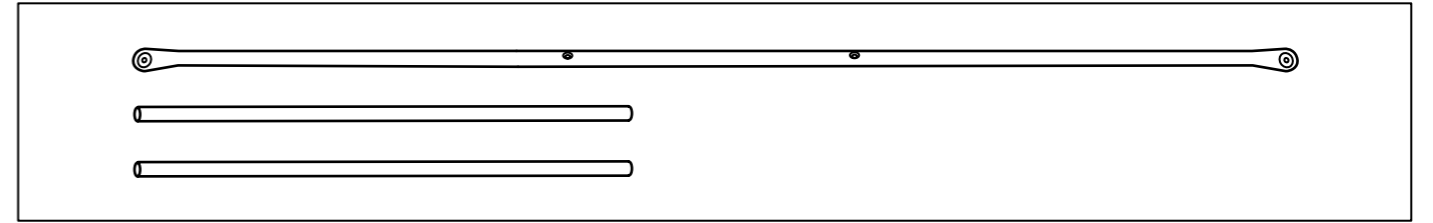
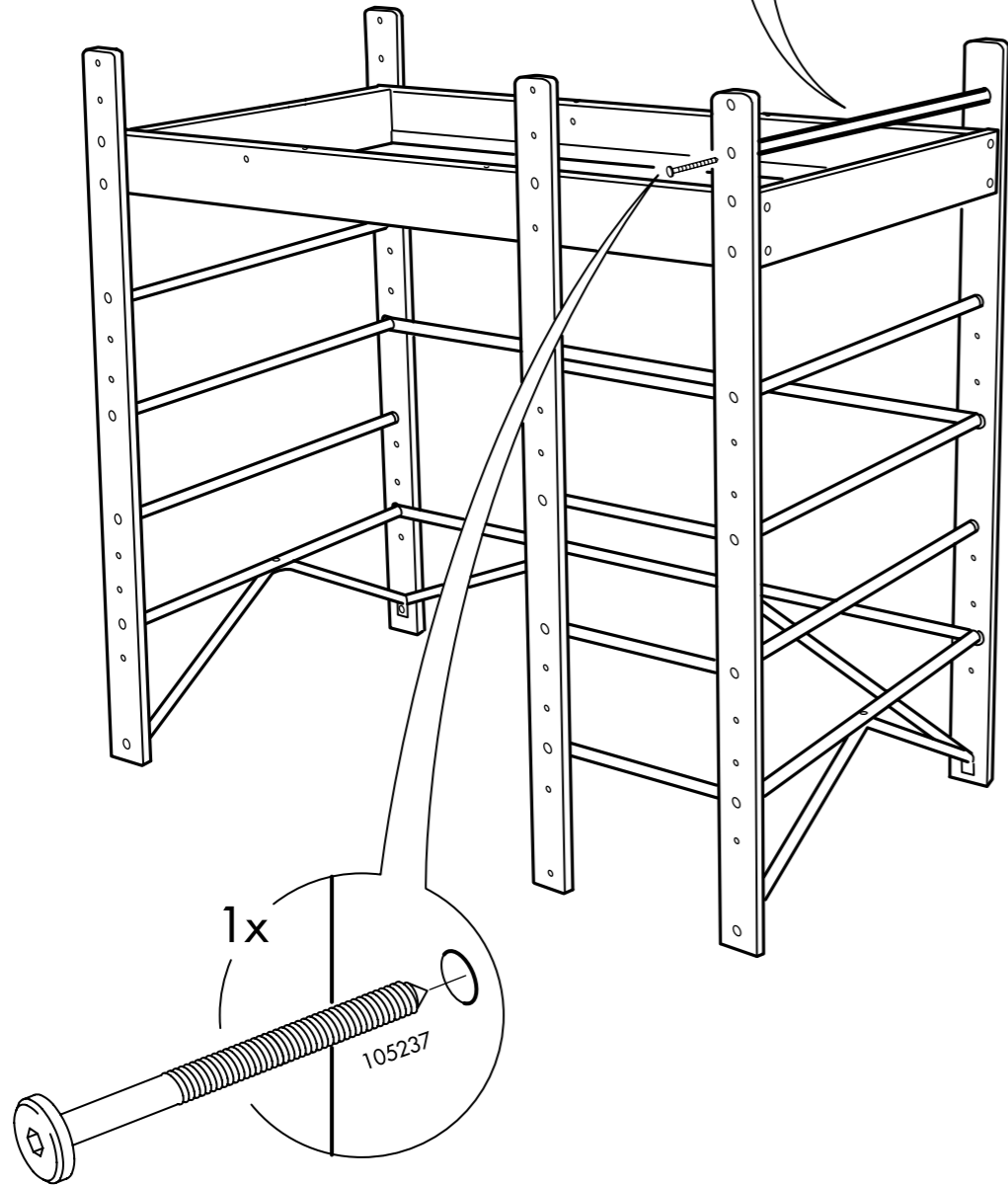
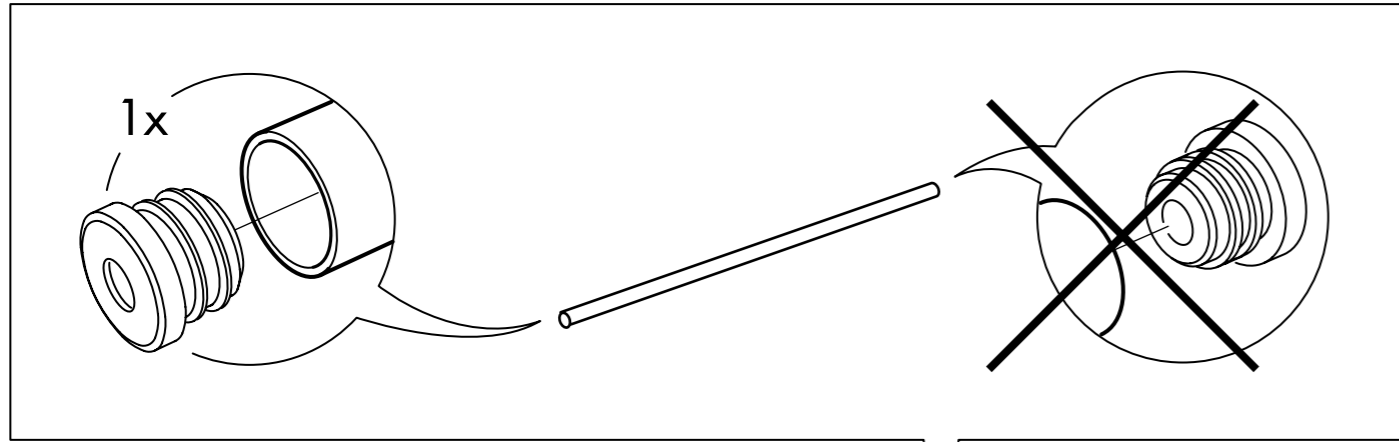
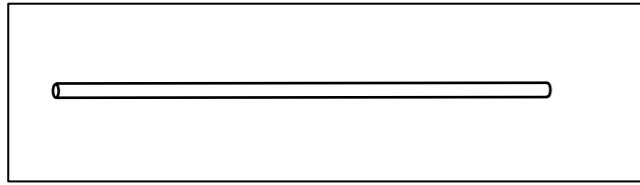

14

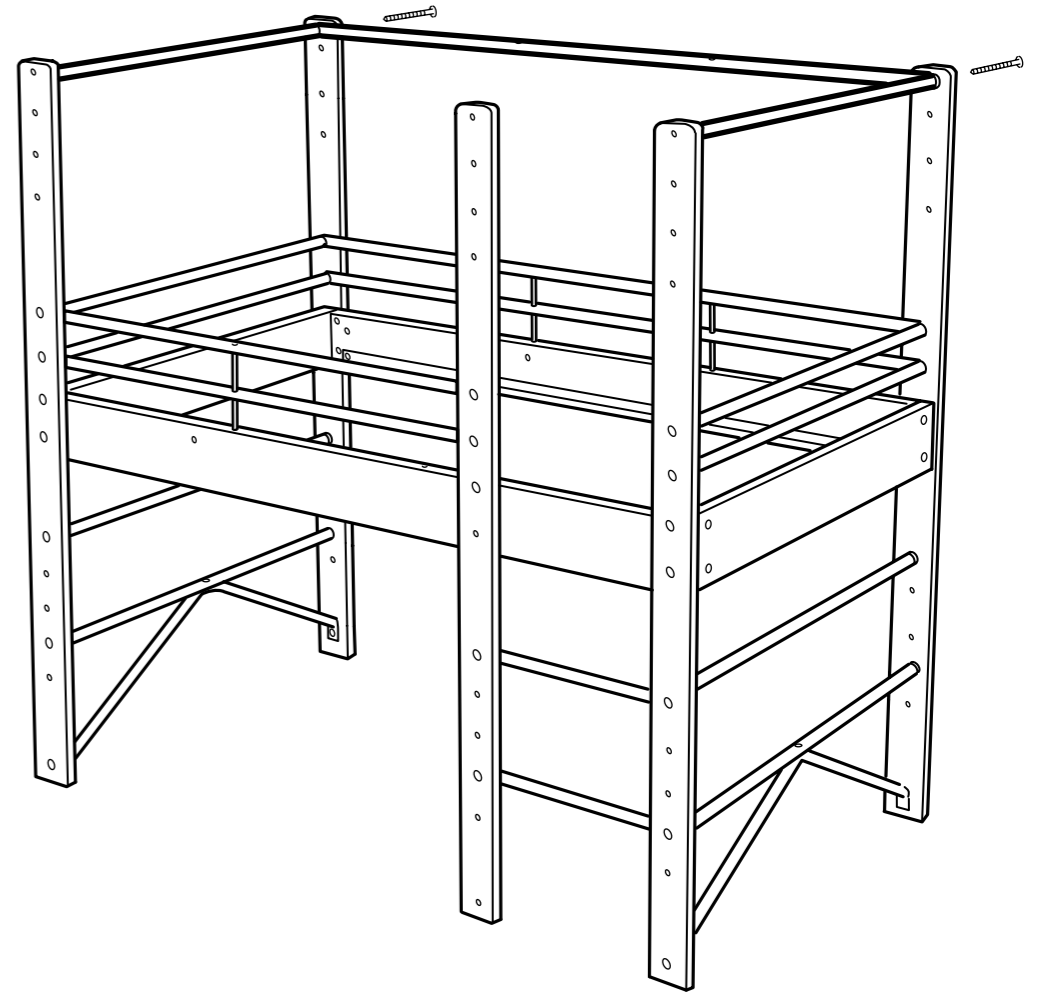
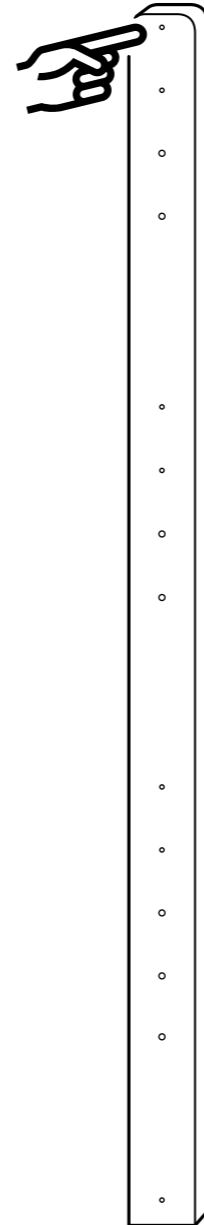
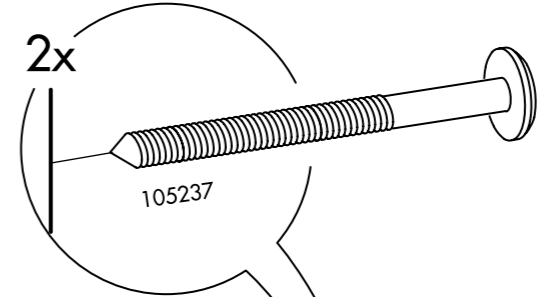

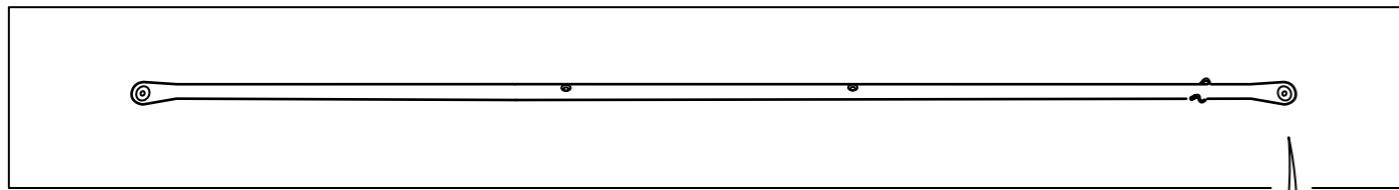

15

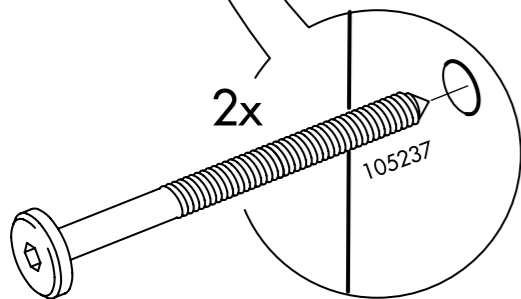
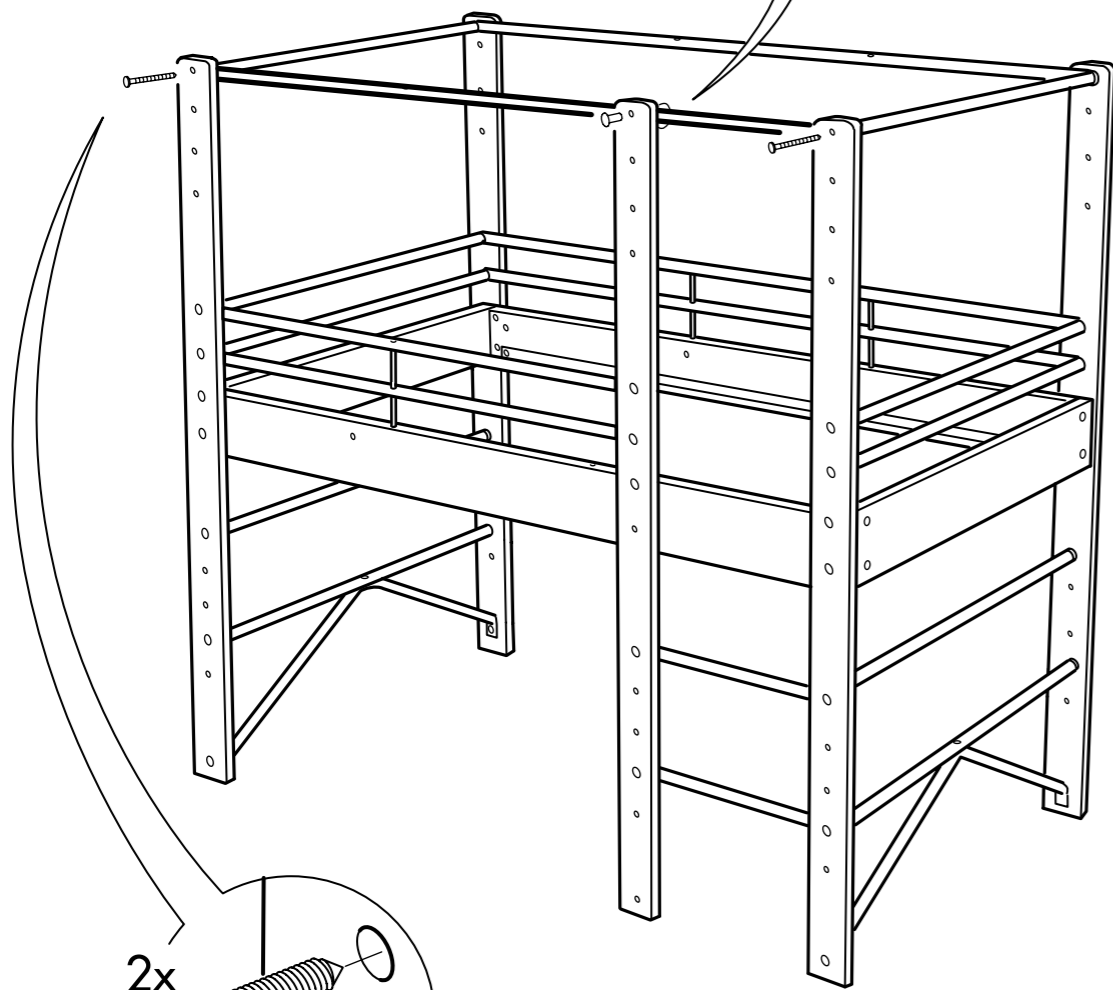
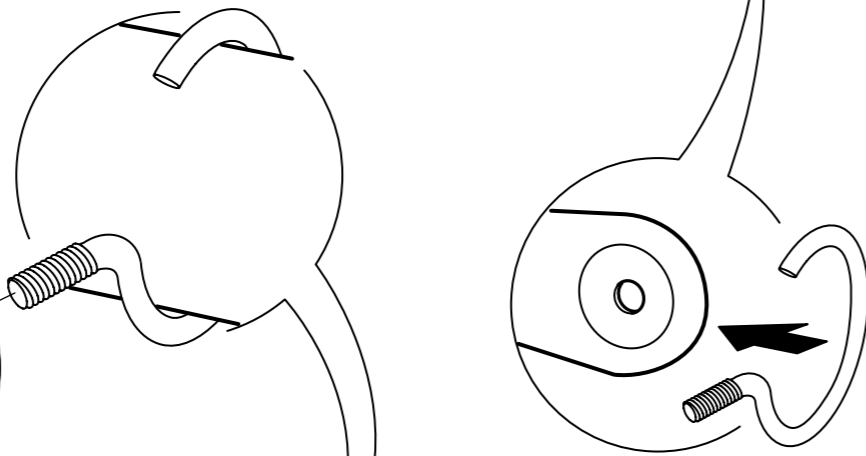
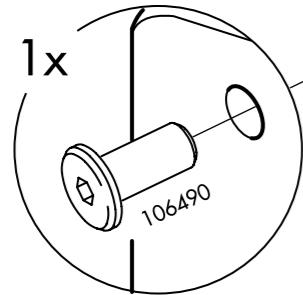

17

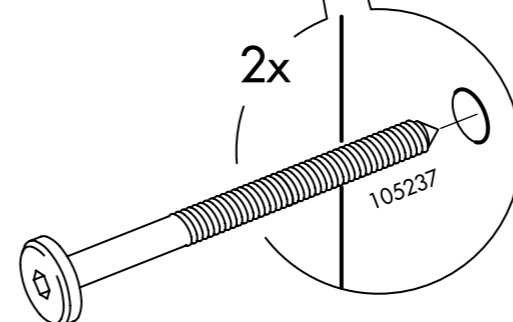
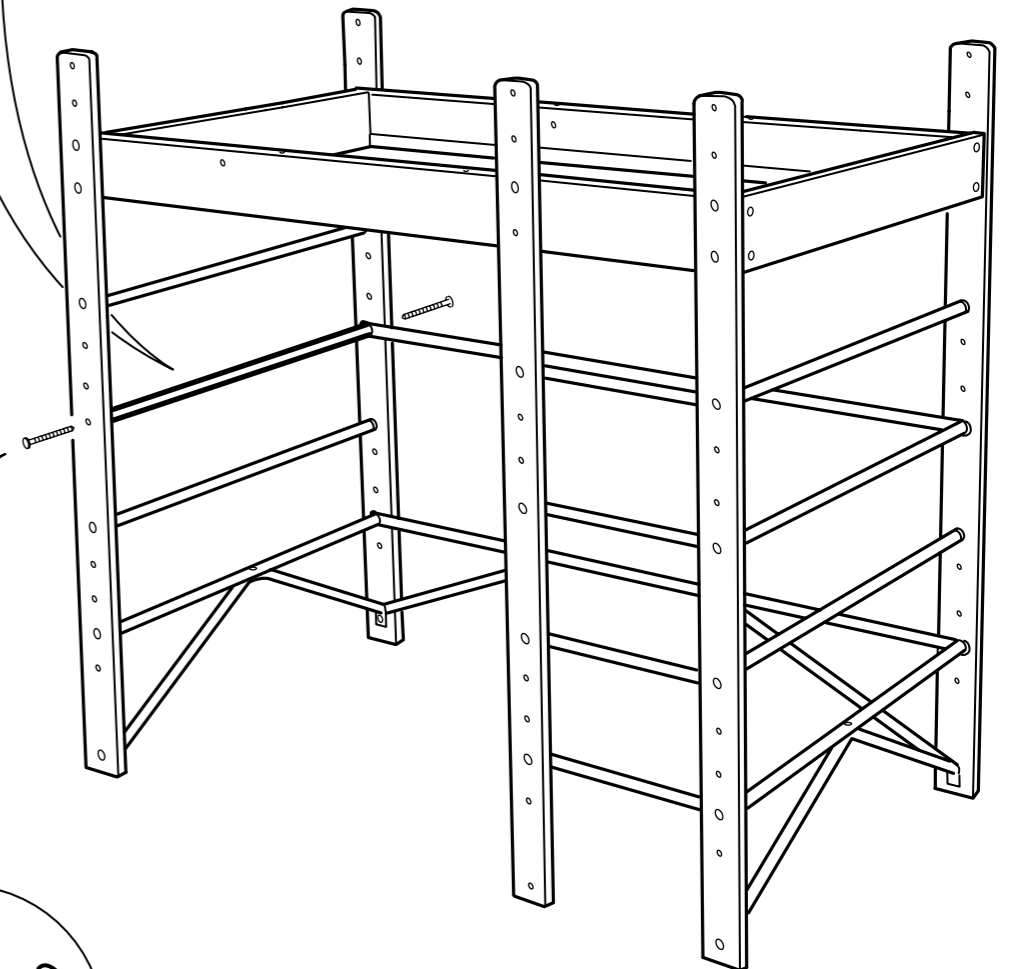
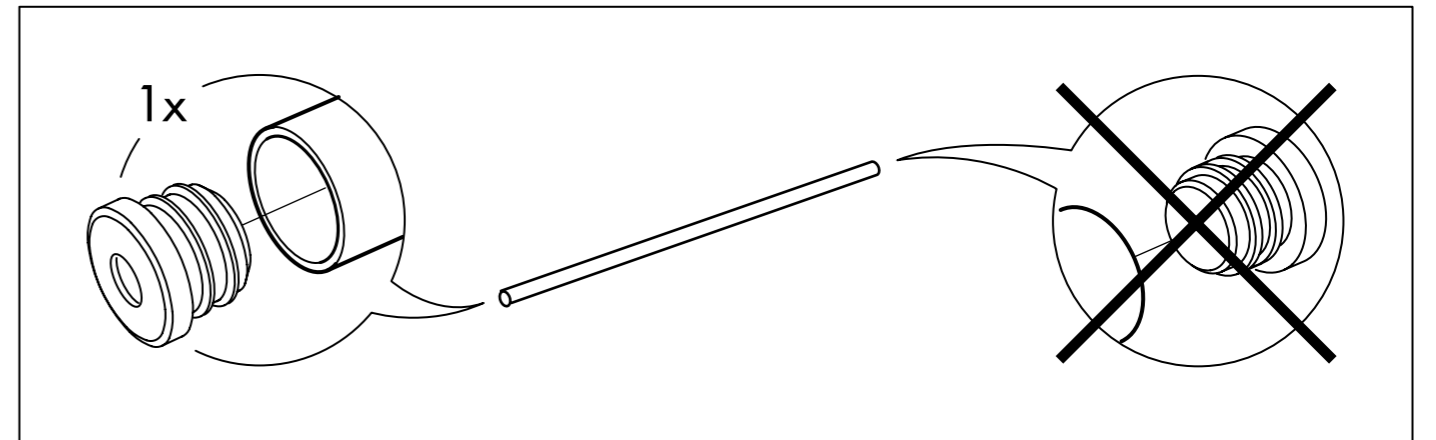
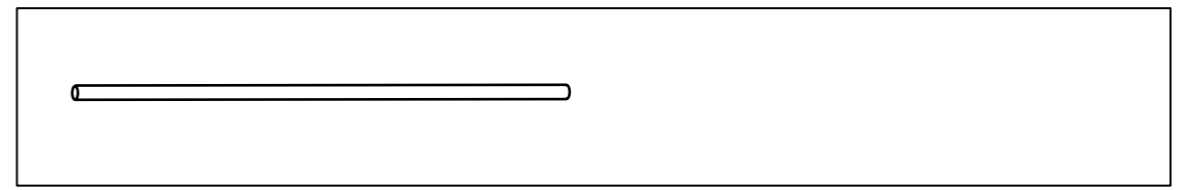

16

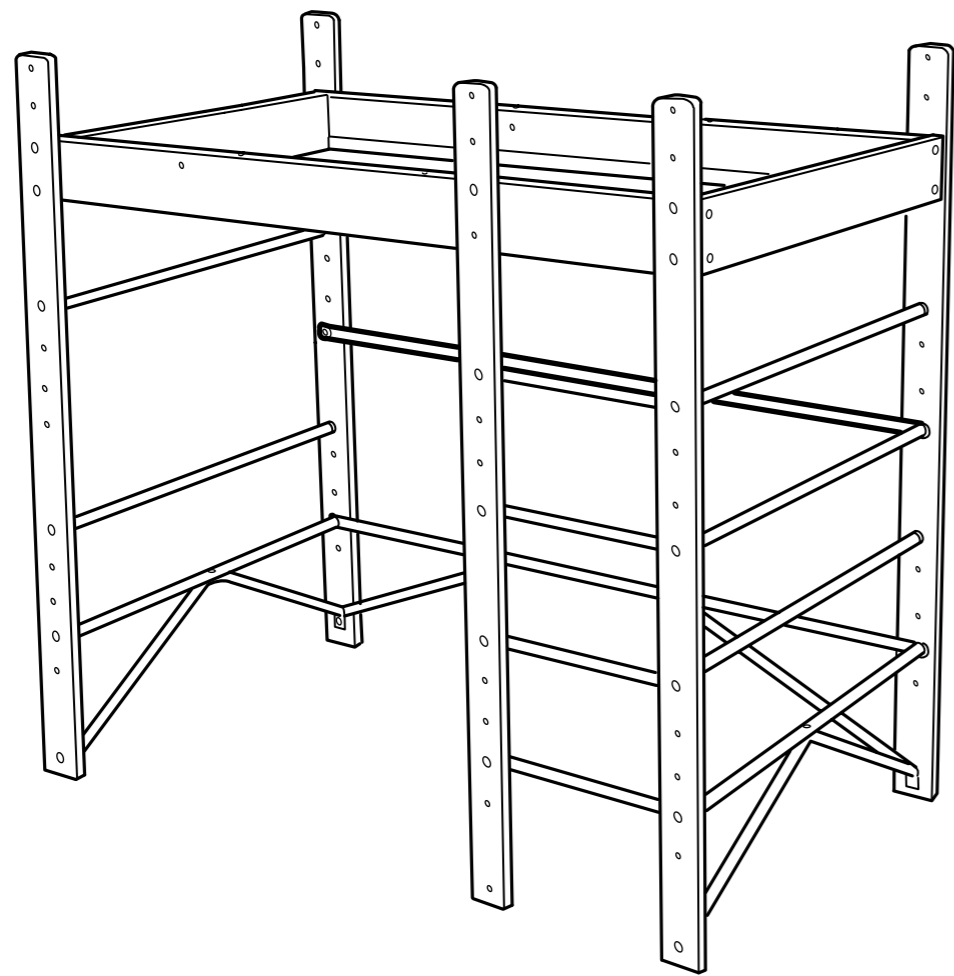
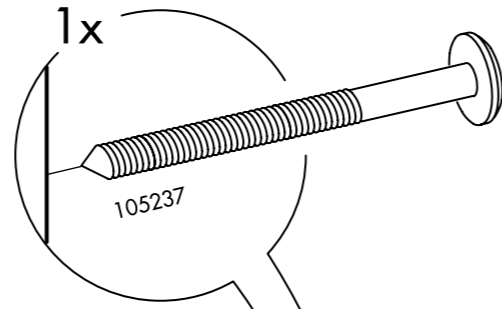
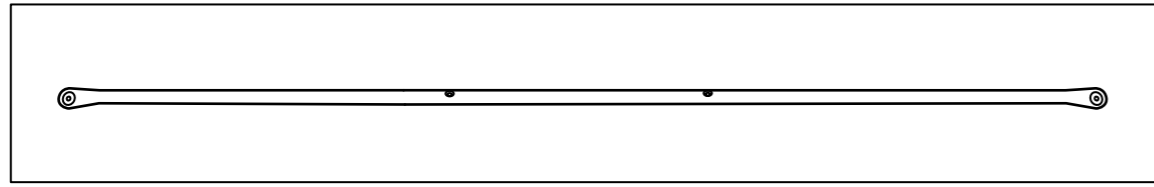

16

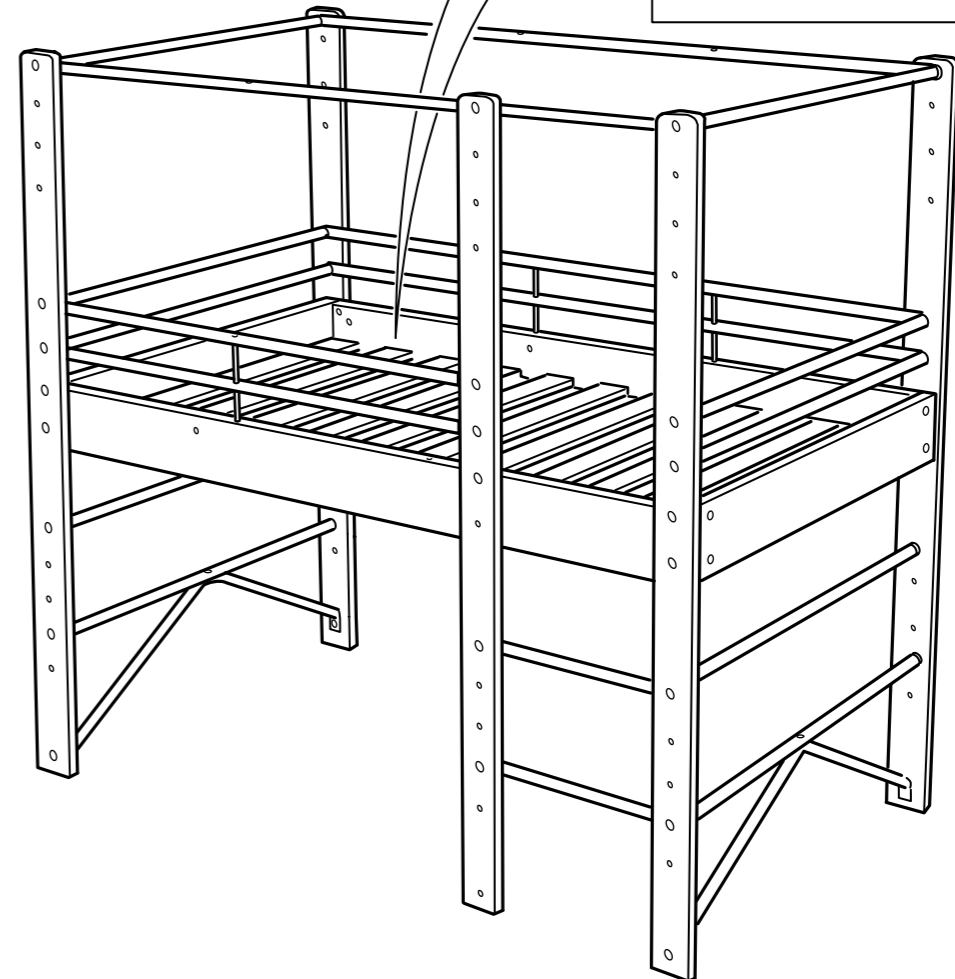
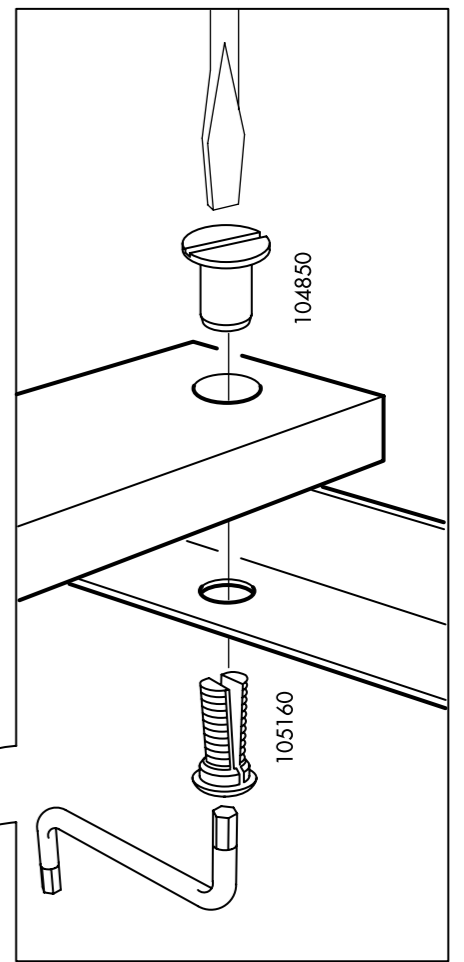

1

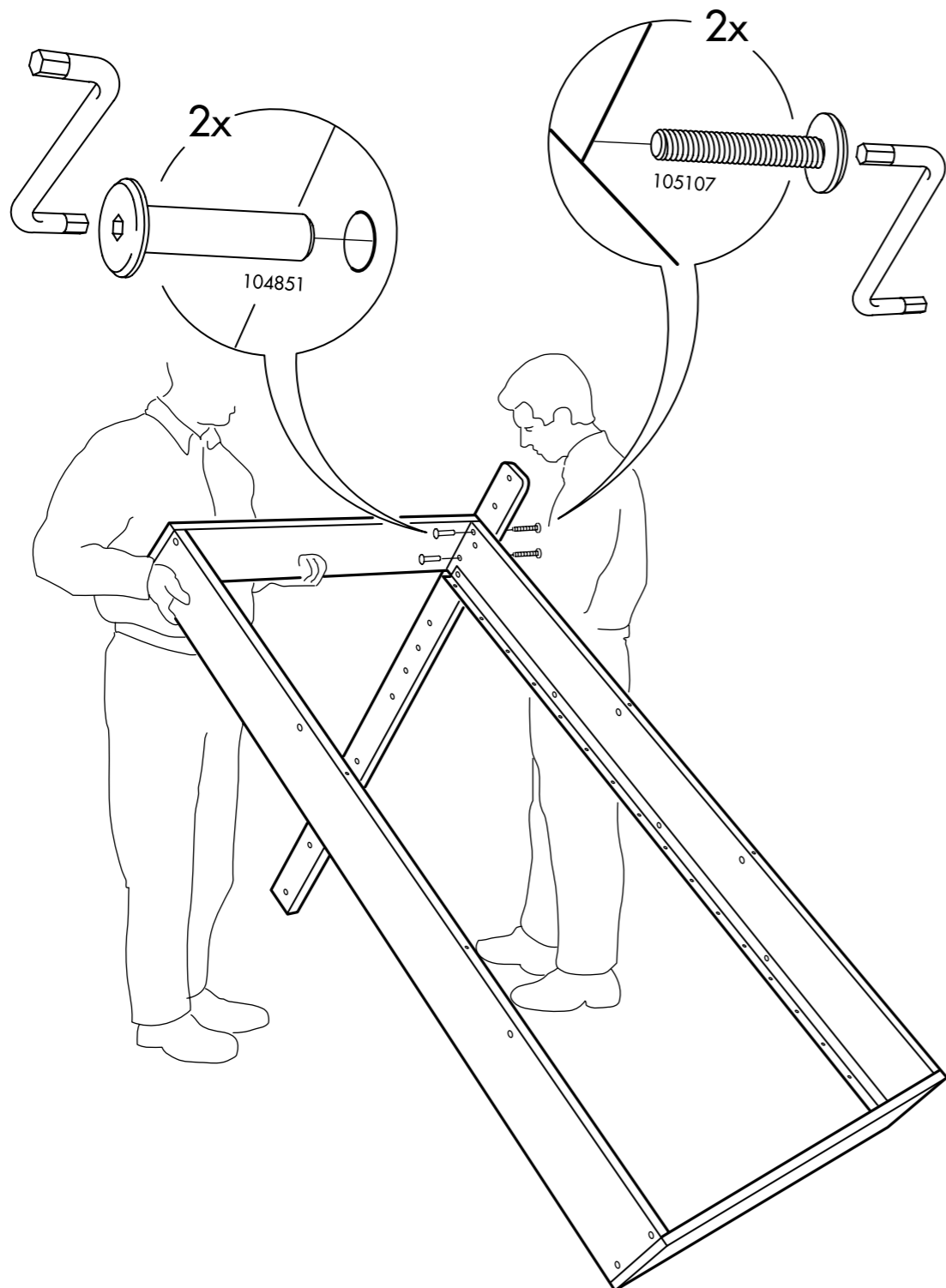
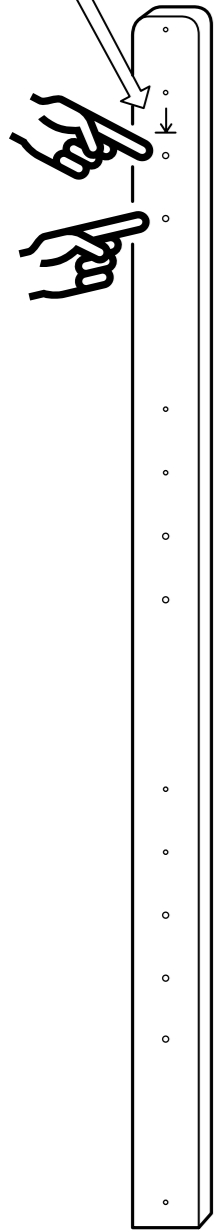
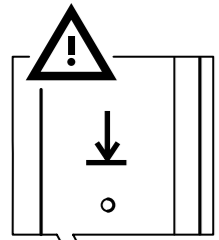
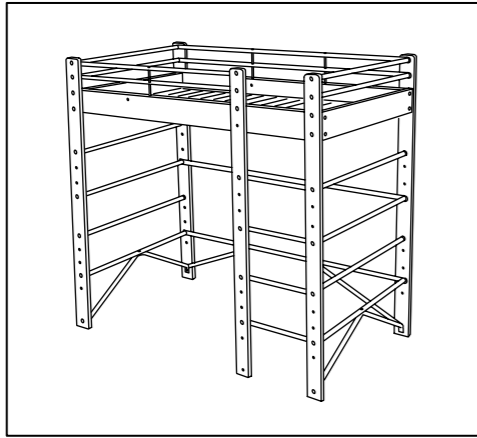

15

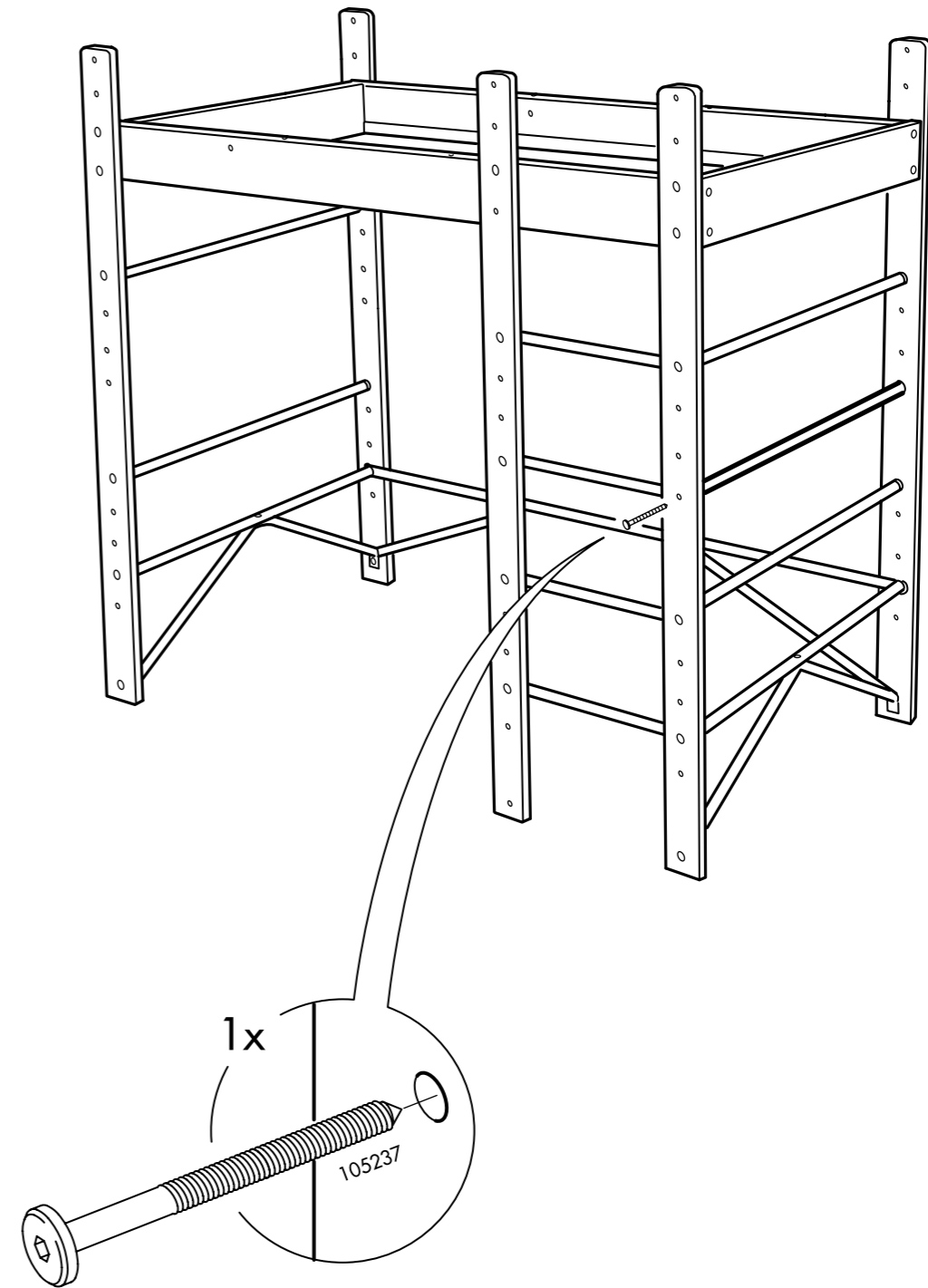
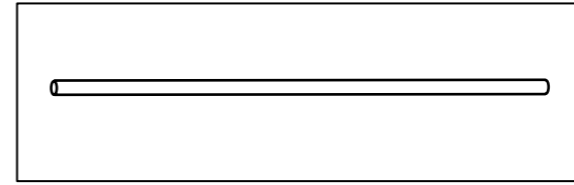

14

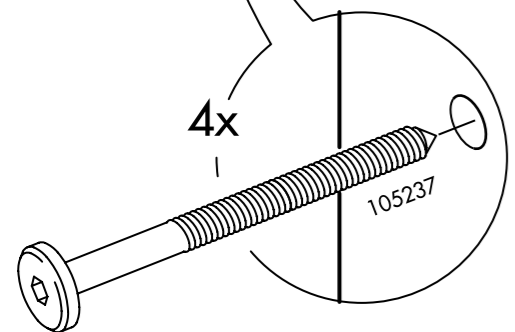
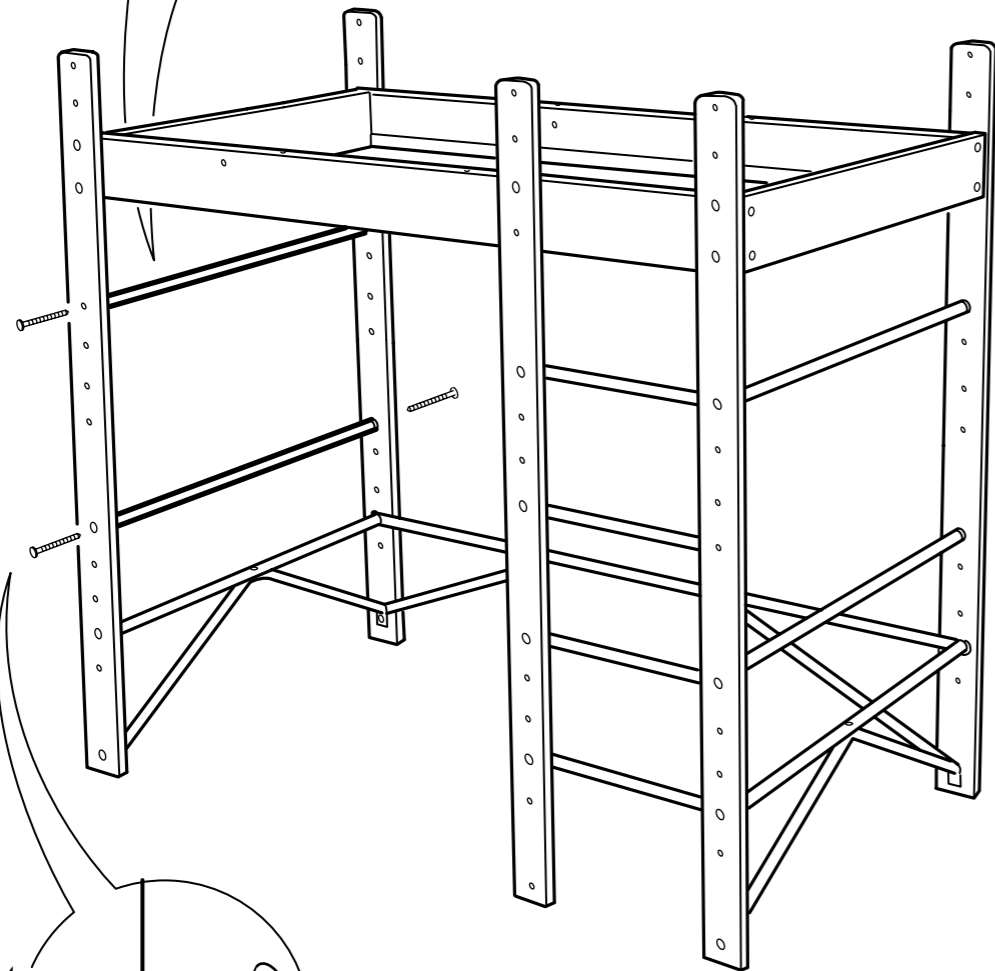
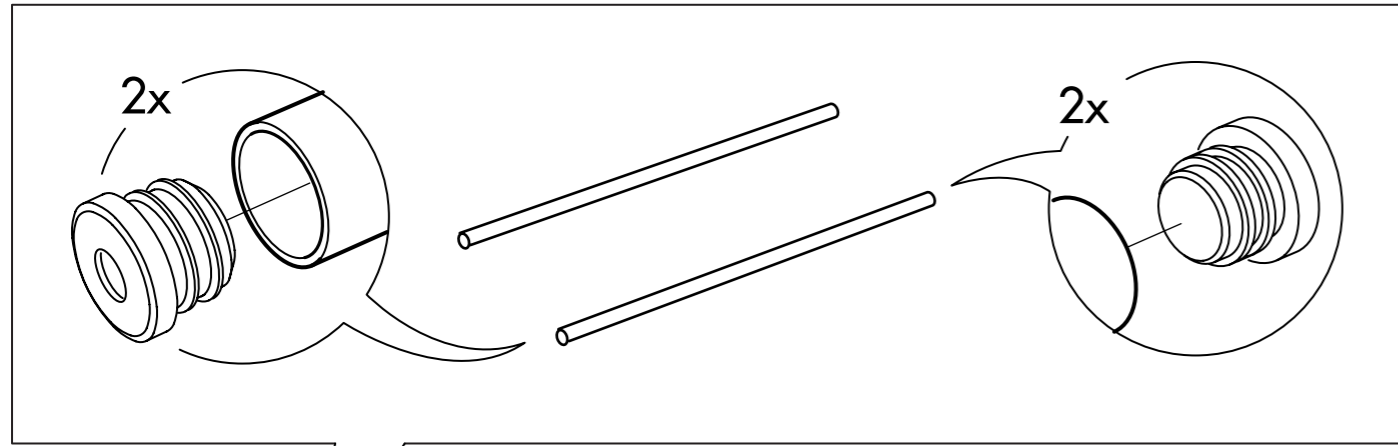
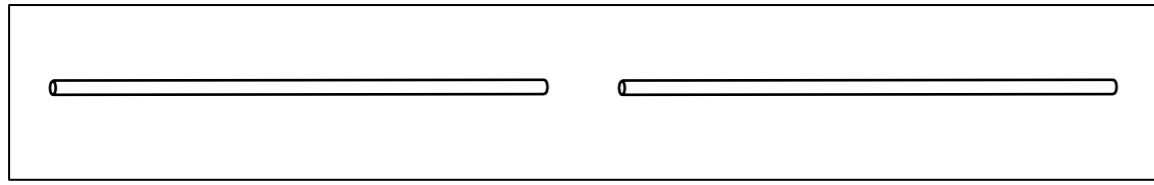

2

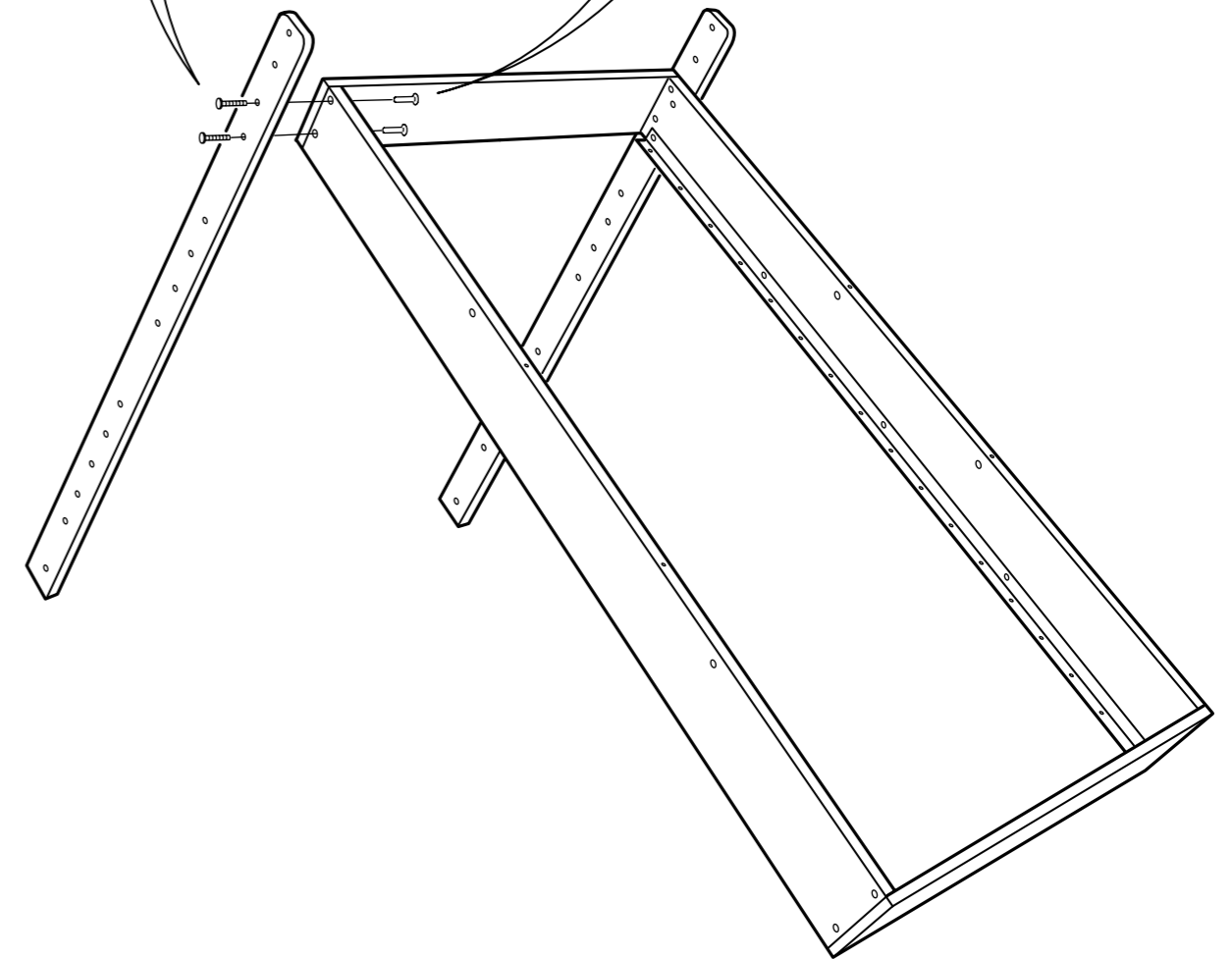
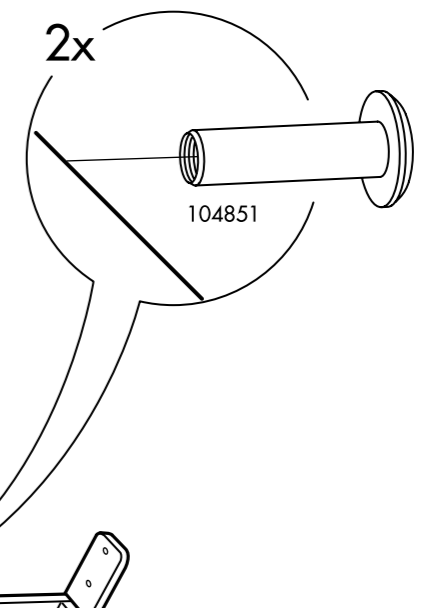
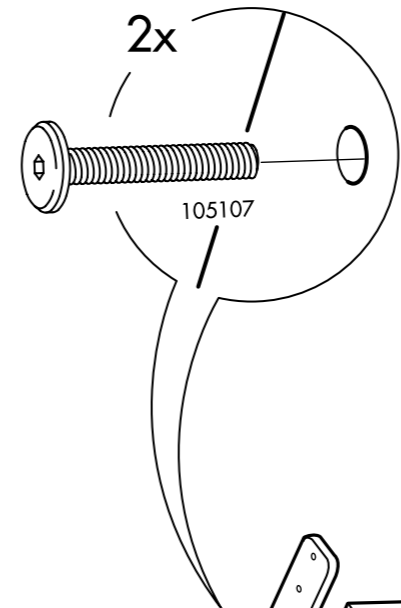

3

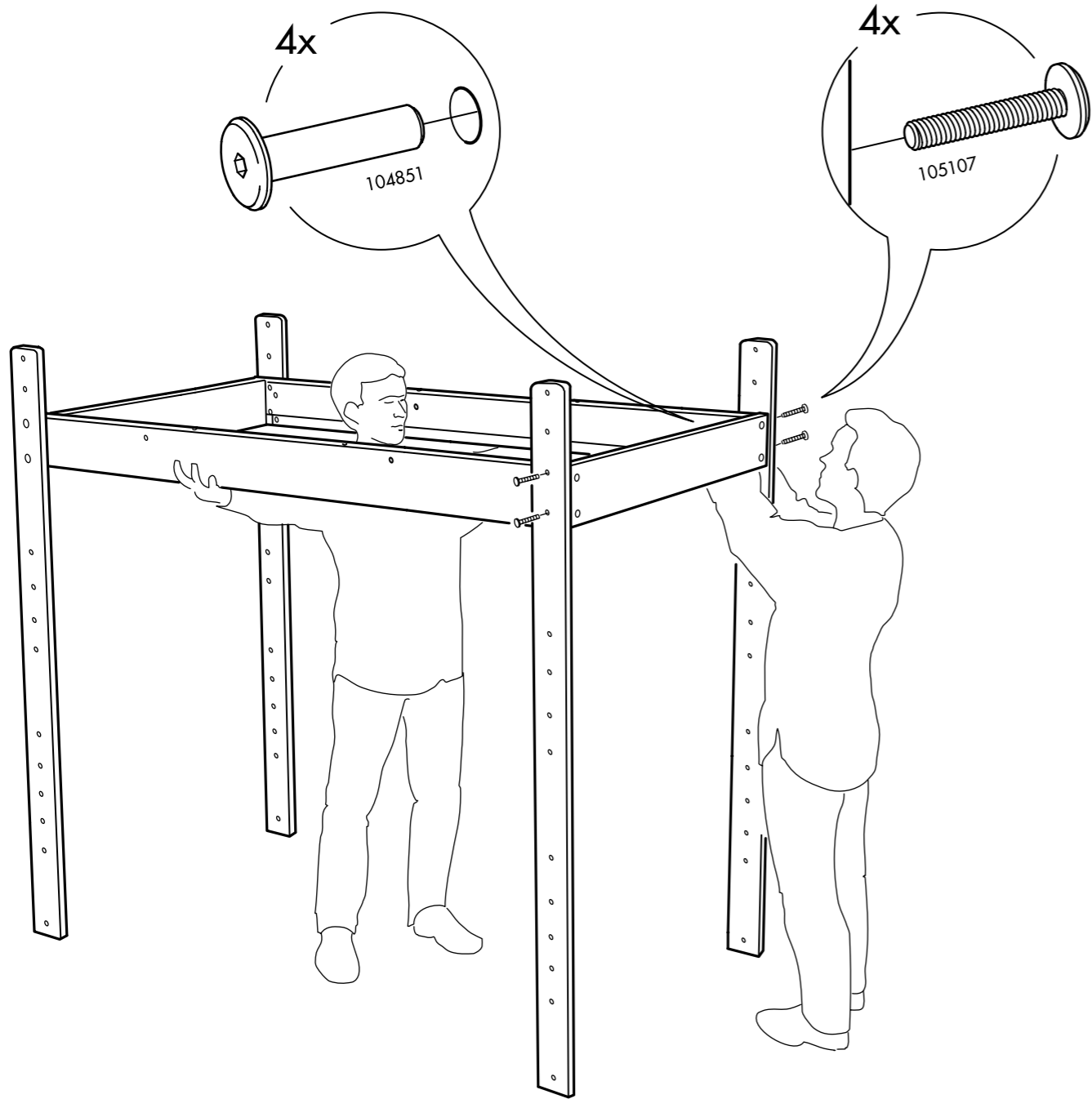

13

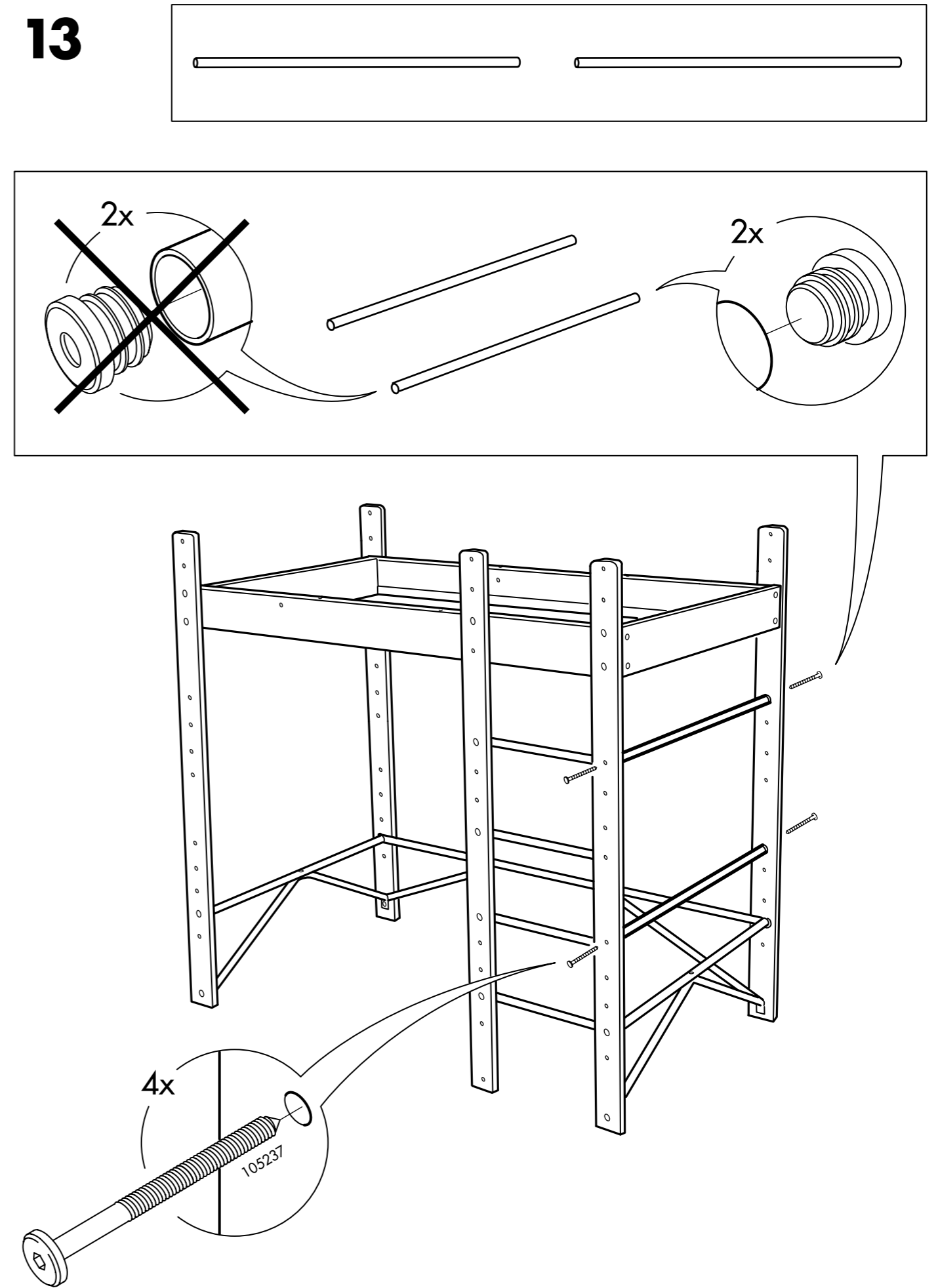

12

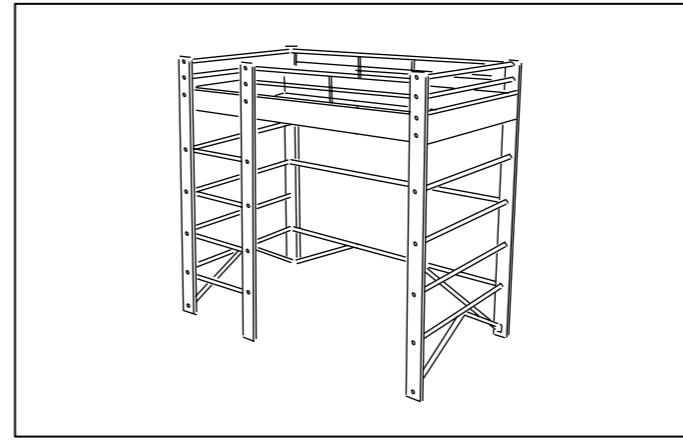
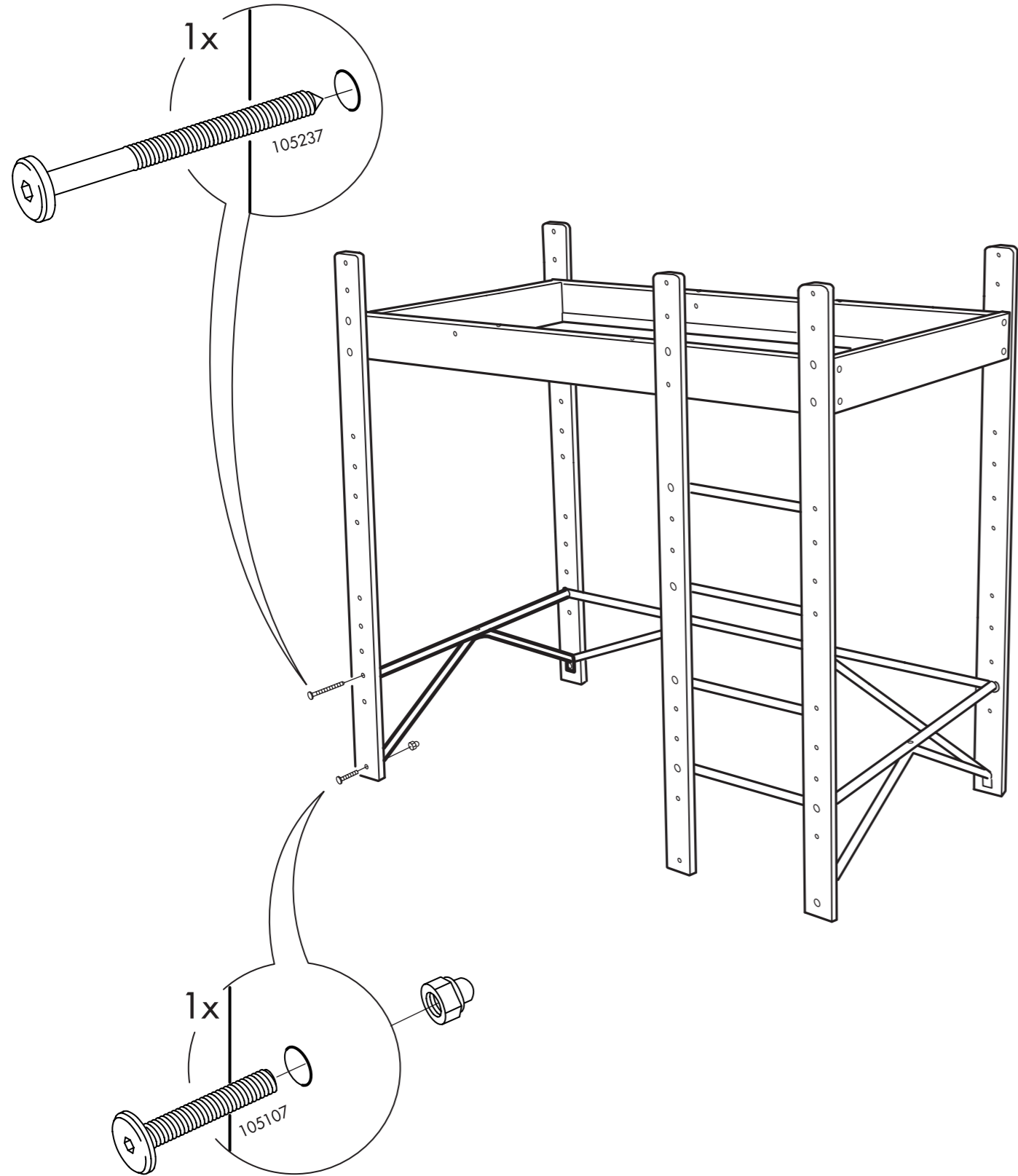

4

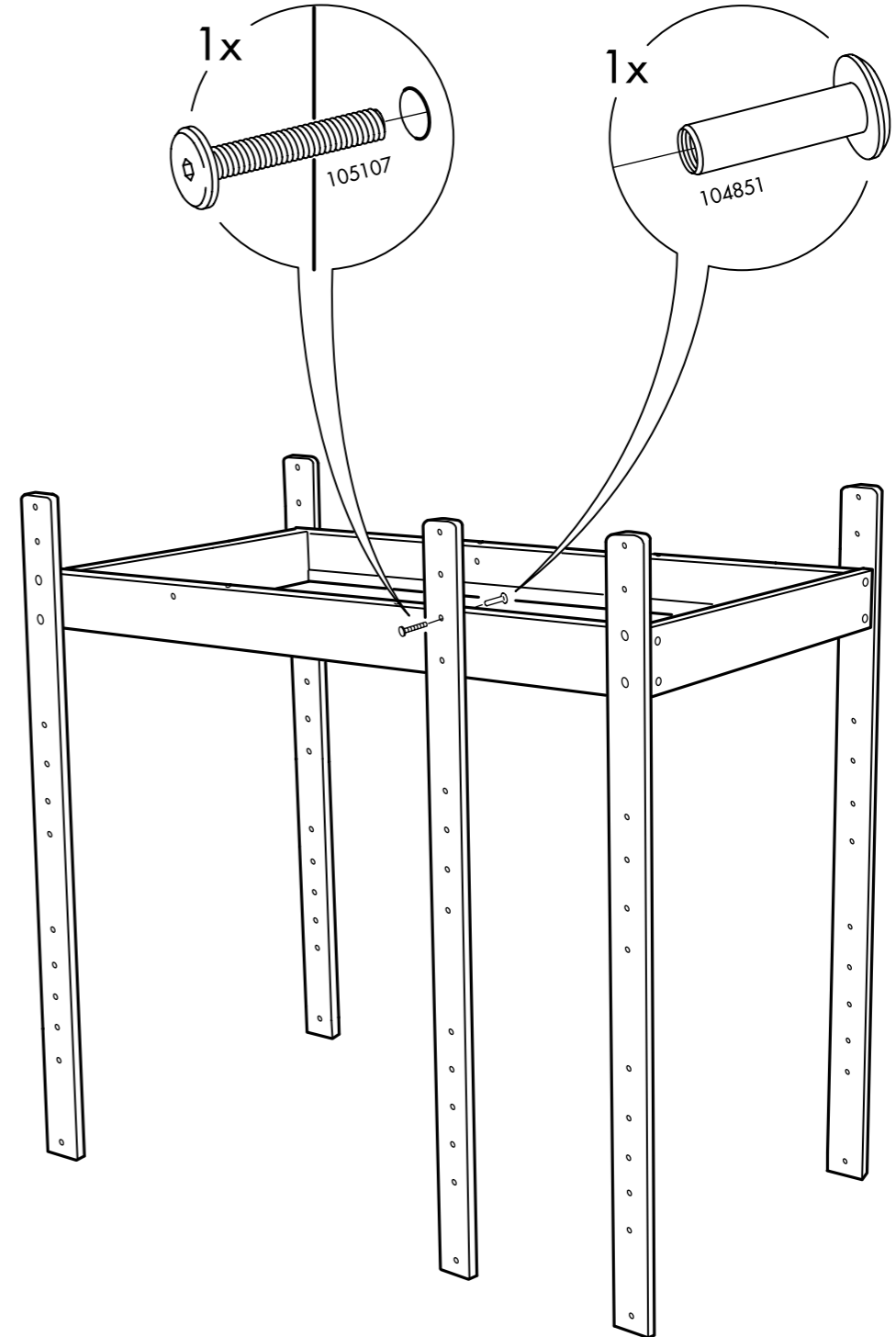

5

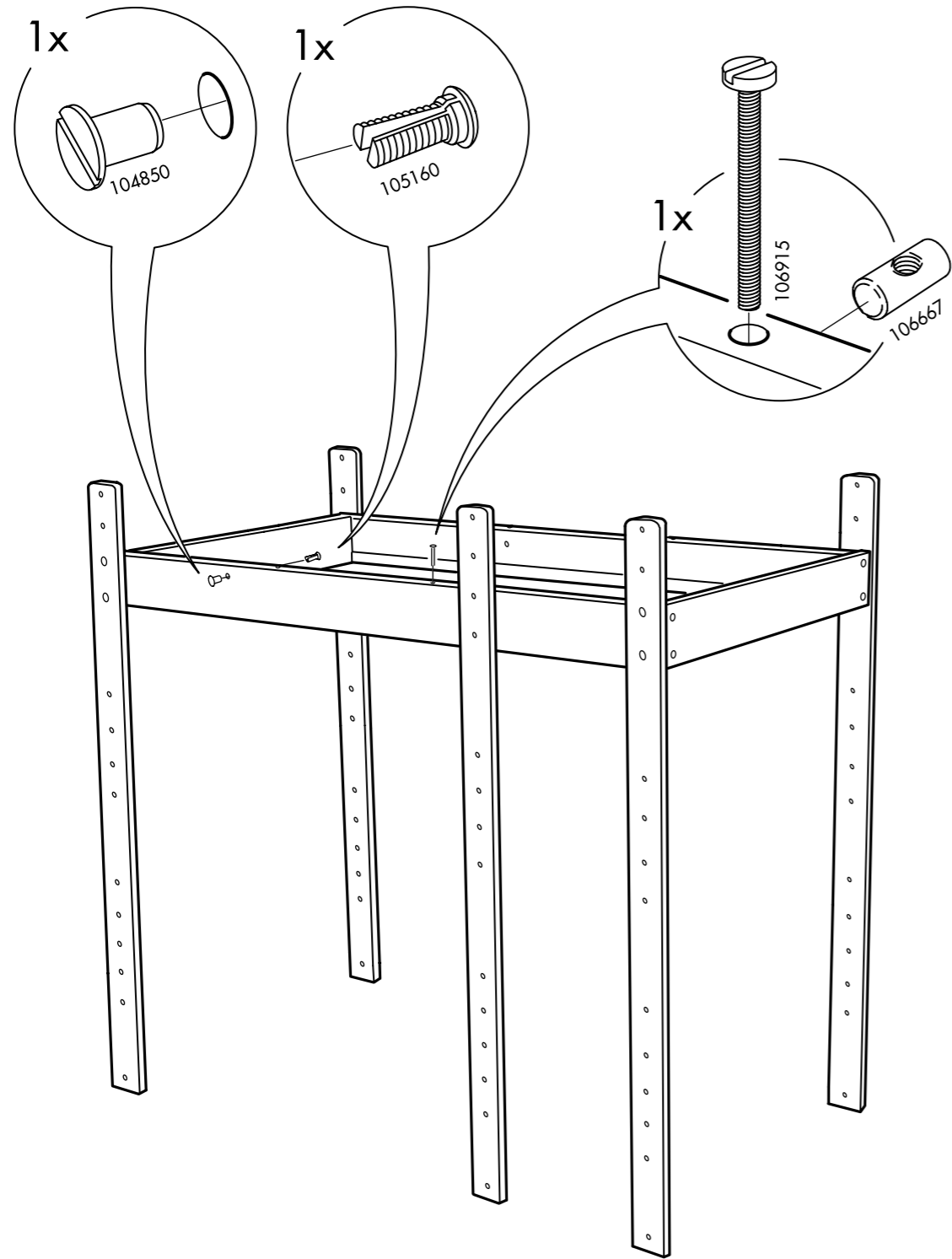

11

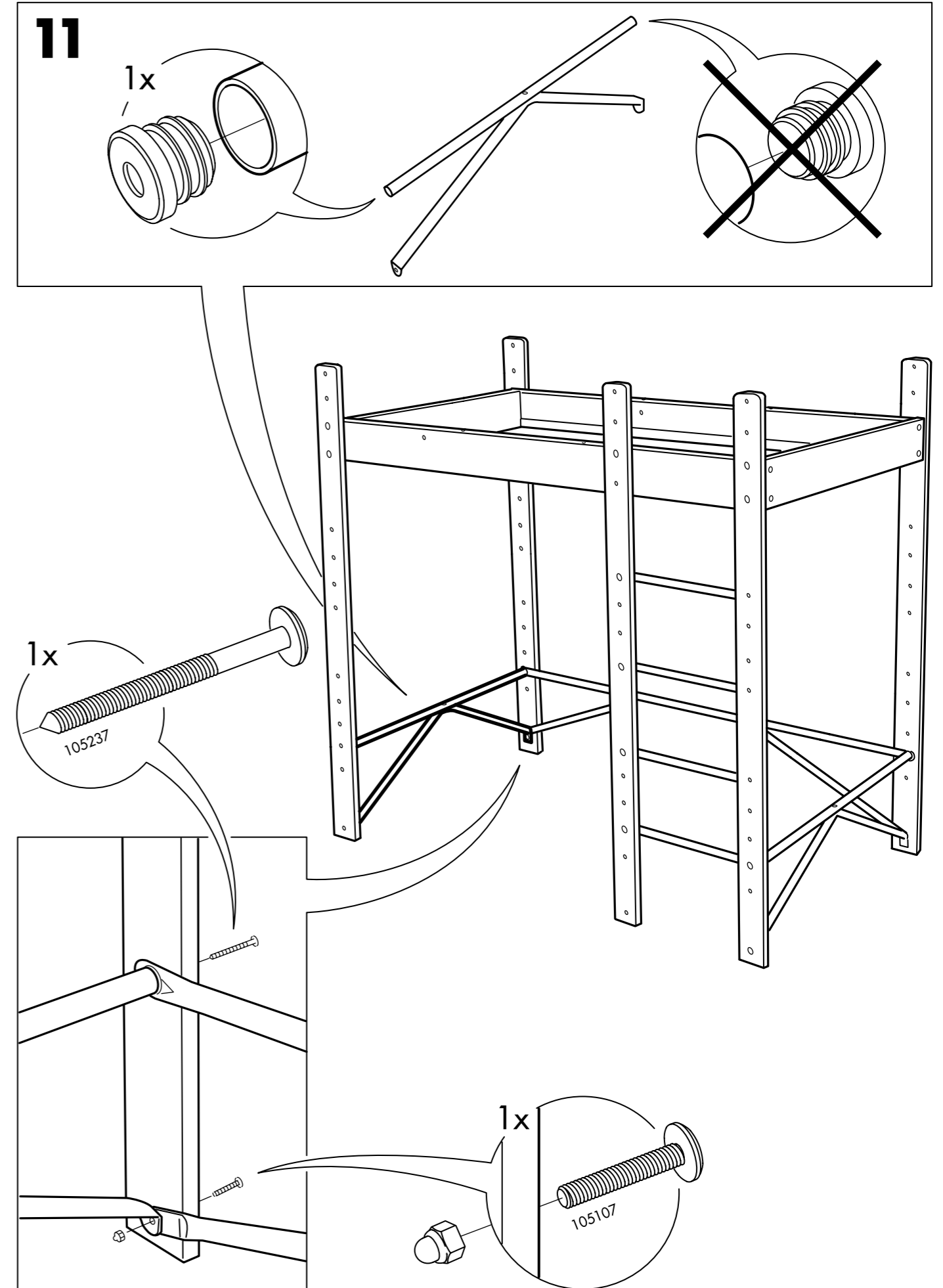

10

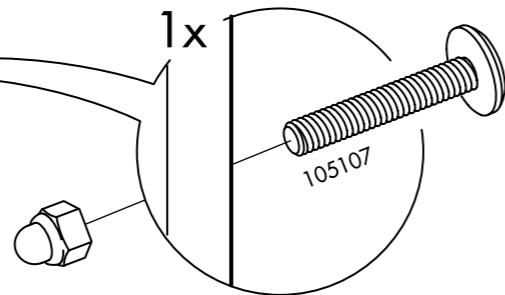
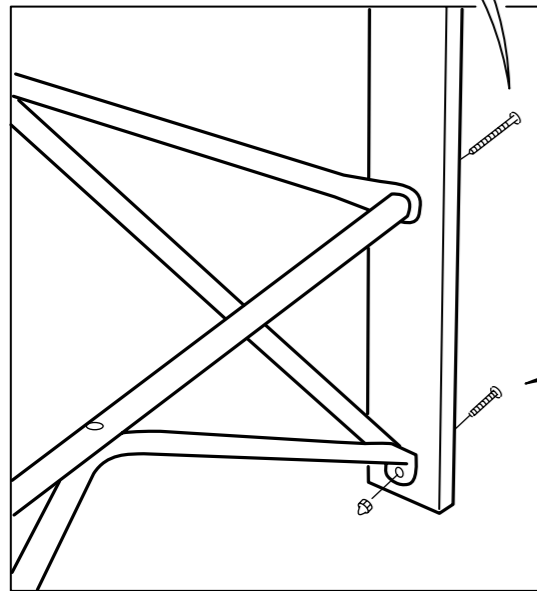
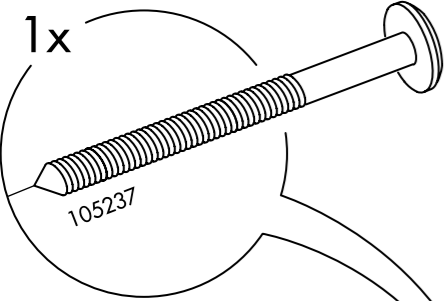
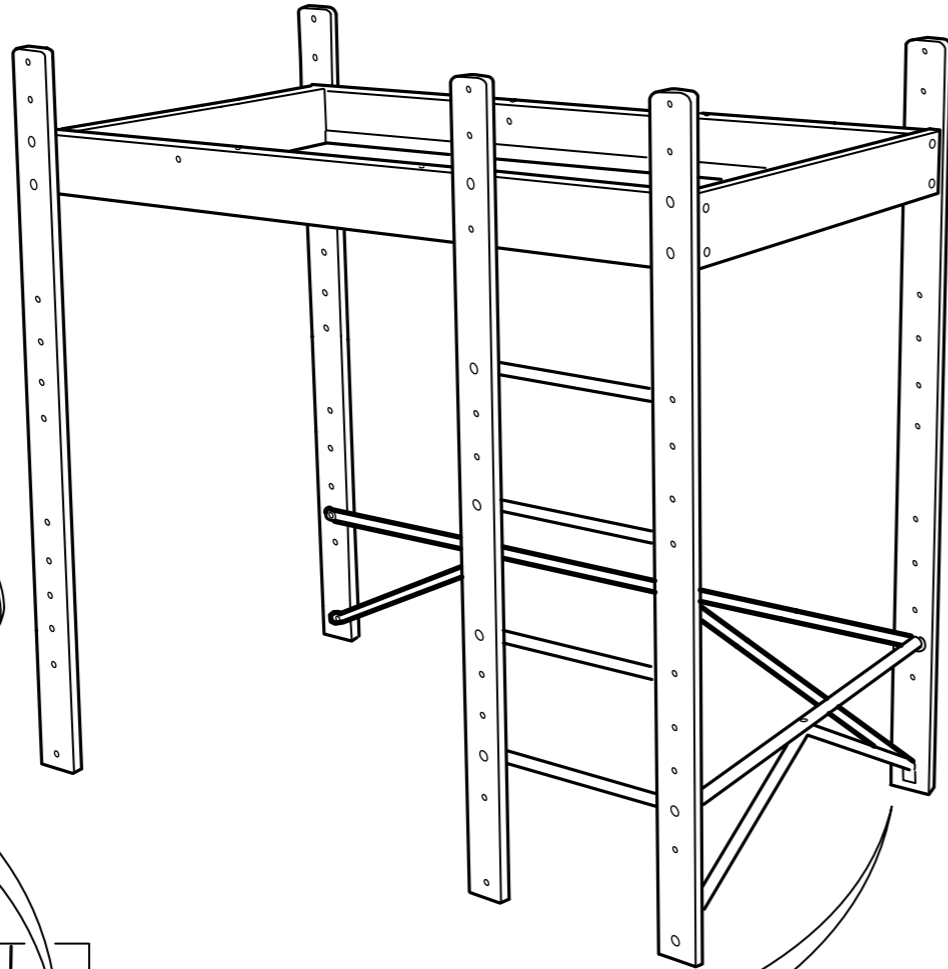
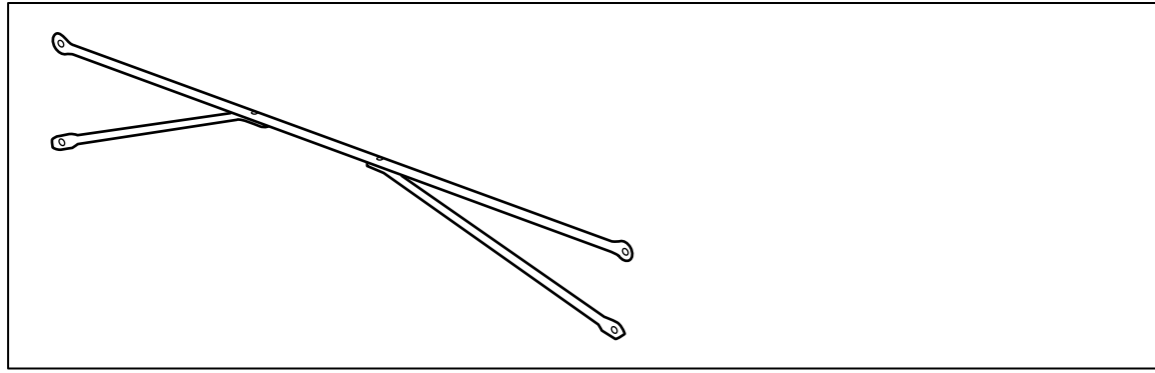

6

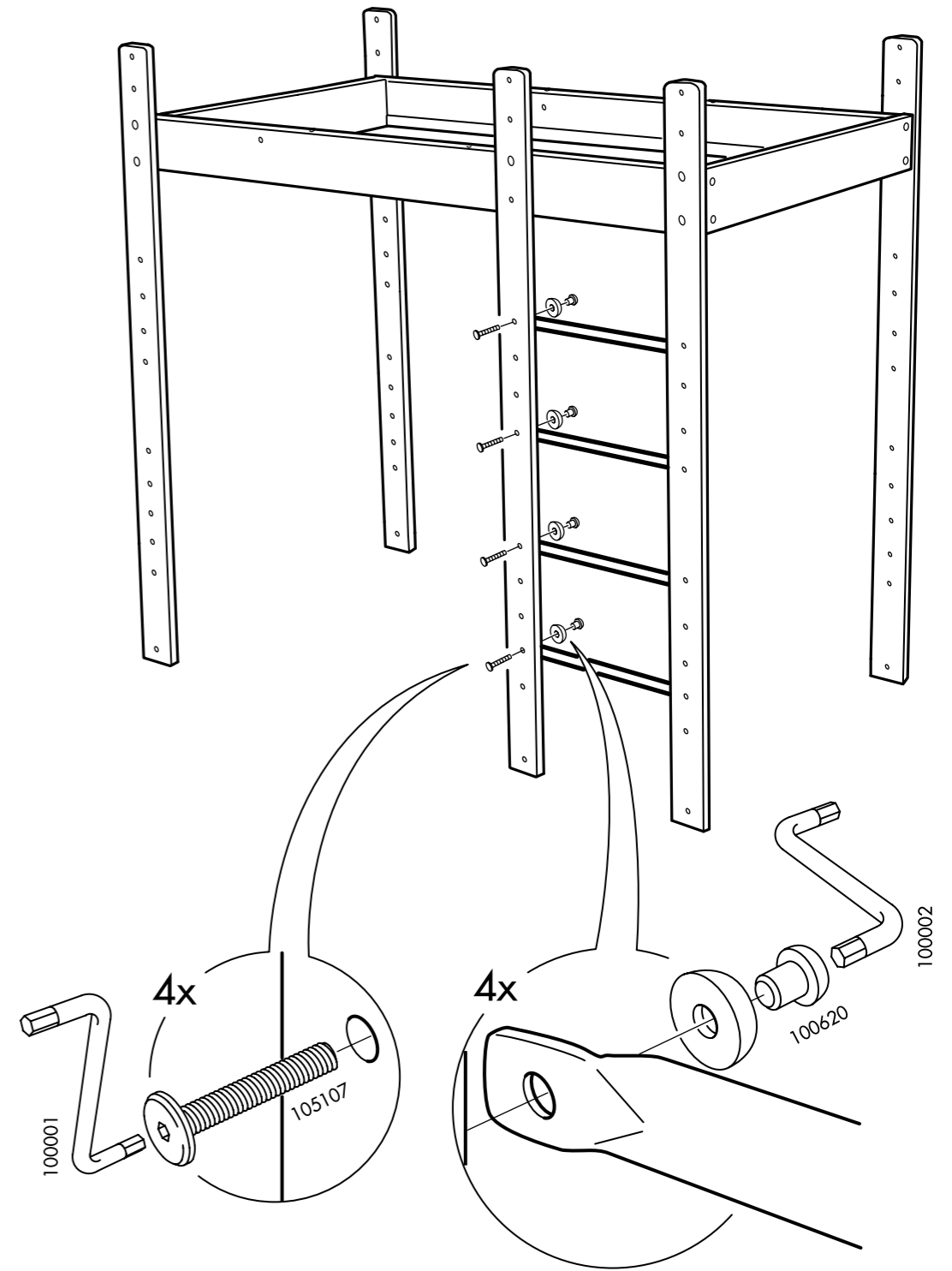
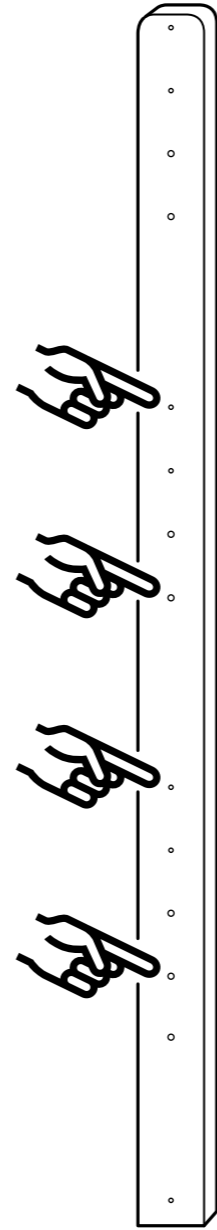

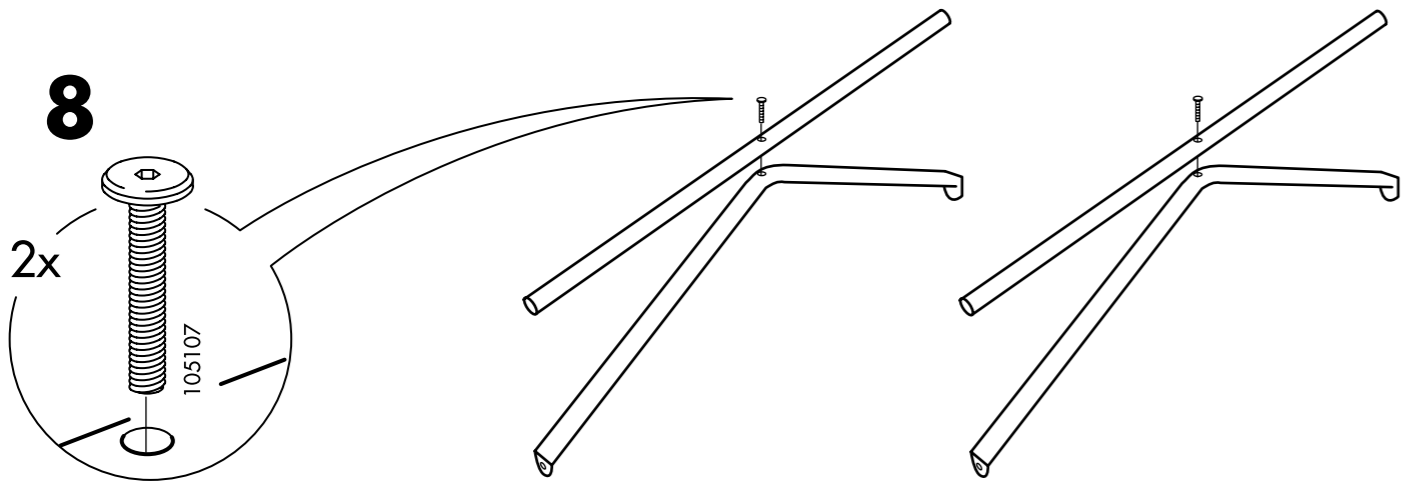
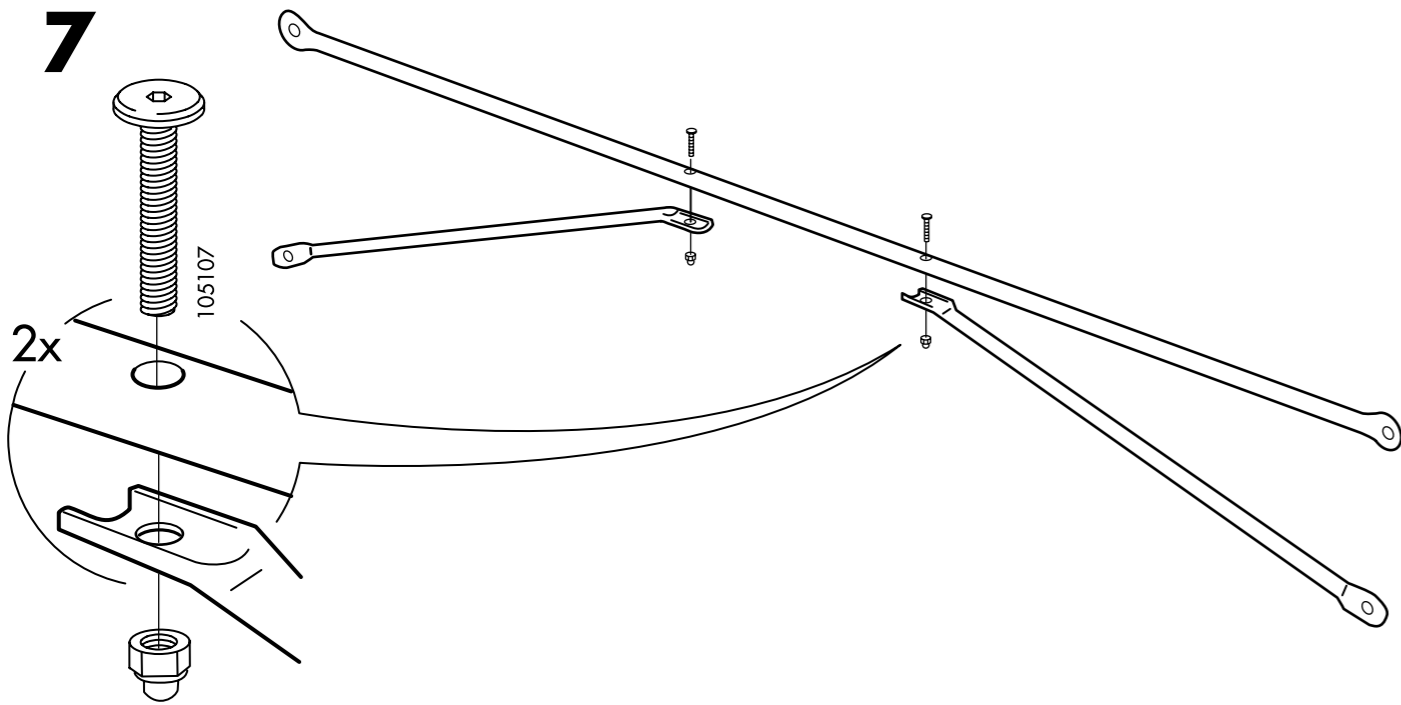
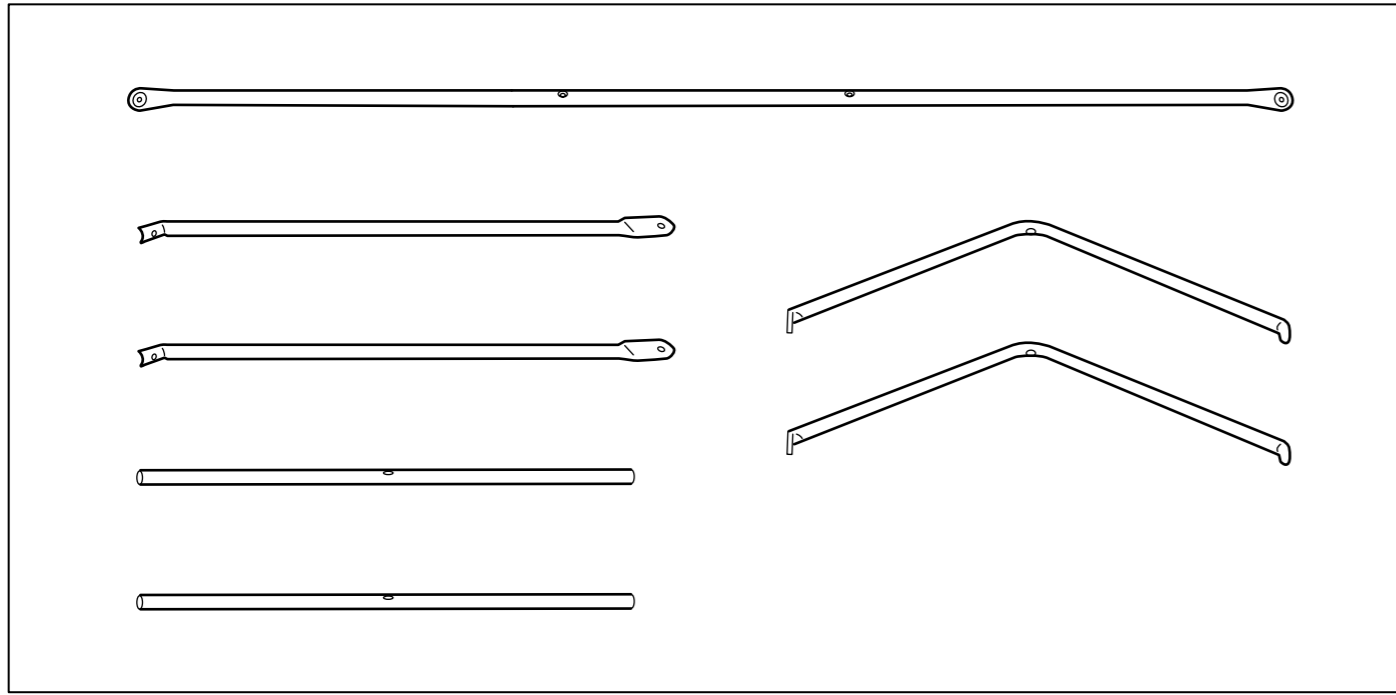

9

