

NOTE:
Please read all instructions
carefully before using this
product

Table of Contents

Safety Notice

Hardware Identifier

Assembly Instruction

Parts List

Warranty

Ordering Parts

Model
SM-1000

Retain This
Manual for
Reference

08-03-09

OWNER'S
MANUAL

IMPEX

MARCY SMITH MACHINE SM-1000

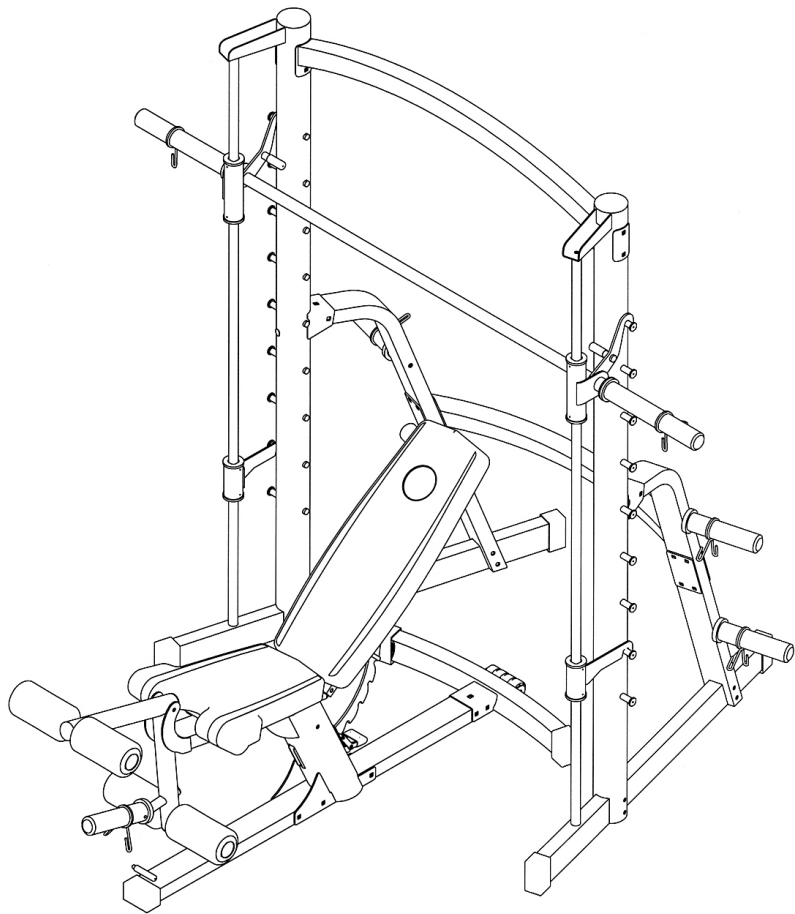

IMPEX® INC.

14777 DON JULIAN RD., CITY OF INDUSTRY, CA 91746

Tel: (800) 999-8899 Fax: (626) 961-9966

www.impex-fitness.com

info@impex-fitness.com

TABLE OF CONTENTS

BEFORE YOU BEGIN.....	1
IMPORTANT SAFETY NOTICES.....	2
SMITH MACHINE HARDWARE PACK.....	4
SMITH MACHINE ASSEMBLY INSTRUCTIONS.....	6
SMITH MACHINE EXPLODED DIAGRAM.....	10
SMITH MACHINE PARTS LIST.....	11
BENCH HARDWARE PACK.....	12
BENCH ASSEMBLY INSTRUCTIONS.....	14
BENCH EXPLODED DIAGRAM.....	19
BENCH PARTS LIST.....	20
WARRANTY.....	21
ORDERING PARTS.....	21

BEFORE YOU BEGIN

Thank you for selecting the MARCY SMITH MACHINE SM-1000 by IMPEX[®] INC. For your safety and benefit, read this manual carefully before using the machine. As a manufacturer, we are committed to provide you complete customer satisfaction. If you have any questions, or find there are missing or damaged parts, we guarantee you complete satisfaction through direct assistance from our factory. To avoid unnecessary delays, *please call our TOLL-FREE customer service number.* Our Customer Service Agents will provide immediate assistance to you.

Toll-Free Customer Service Number

1-800-999-8899

Mon. - Fri. 9 a.m. - 5 p.m. PST

www.impex-fitness.com

info@impex-fitness.com

IMPORTANT SAFETY NOTICE

PRECAUTIONS

This exercise machine is built for optimum safety. However, certain precautions apply whenever you operate a piece of exercise equipment. Be sure to read the entire manual before you assemble or operate your machine. In particular, note the following safety precautions:

1. **Keep children and pets away from the machine at all times. DO NOT leave children unattended in the same room with the machine.**
2. Only one person at a time should use the machine.
3. If the user experiences dizziness, nausea, chest pain, or any other abnormal symptoms, STOP the workout at once. CONSULT A PHYSICIAN IMMEDIATELY.
4. Position the machine on a clear, leveled surface. DO NOT use the machine near water or outdoors.
5. Keep hands away from all moving parts.
6. Always wear appropriate workout clothing when exercising. DO NOT wear robes or other clothing that could become caught in the machine. Running or aerobic shoes are also required when using the machine.
7. Use the machine only for its intended use as described in this manual. DO NOT use attachments not recommended by the manufacturer.
8. Do not place any sharp object around the machine.
9. Disabled person should not use the machine without a qualified person or physician in attendance.
10. Before using the machine to exercise, always do stretching exercises to properly warm up.
11. Never operate the machine if the machine is not functioning properly.
12. A spotter is recommended during exercise.

CARE AND MAINTENANCE

1. Lubricate moving parts and Guide Rods with WD-40 or light oil periodically.
2. Inspect and tighten all parts before using the machine.
3. The machine can be cleaned using a damp cloth and mild non-abrasive detergent. DO NOT use solvents.
4. Maximum user's weight: 300 lbs.
5. Maximum weight on Leg Developer: 100 lbs.
6. Maximum weight on Weight Bar: 300lbs.
7. Maximum weight Capacity: 600 lbs.

WARNING: BEFORE BEGINNING ANY EXERCISE PROGRAM, CONSULT YOUR PHYSICIAN. THIS IS ESPECIALLY IMPORTANT FOR INDIVIDUALS OVER THE AGE OF 35 OR PERSONS WITH PRE-EXISTING HEALTH PROBLEMS. READ ALL INSTRUCTIONS BEFORE USING ANY FITNESS EQUIPMENT. IMPEX INC. ASSUMES NO RESPONSIBILITY FOR PERSONAL INJURY OR PROPERTY DAMAGE SUSTAINED BY OR THROUGH THE USE OF THIS PRODUCT.

SAVE THESE INSTRUCTIONS.

WARNING LABEL PLACEMENT

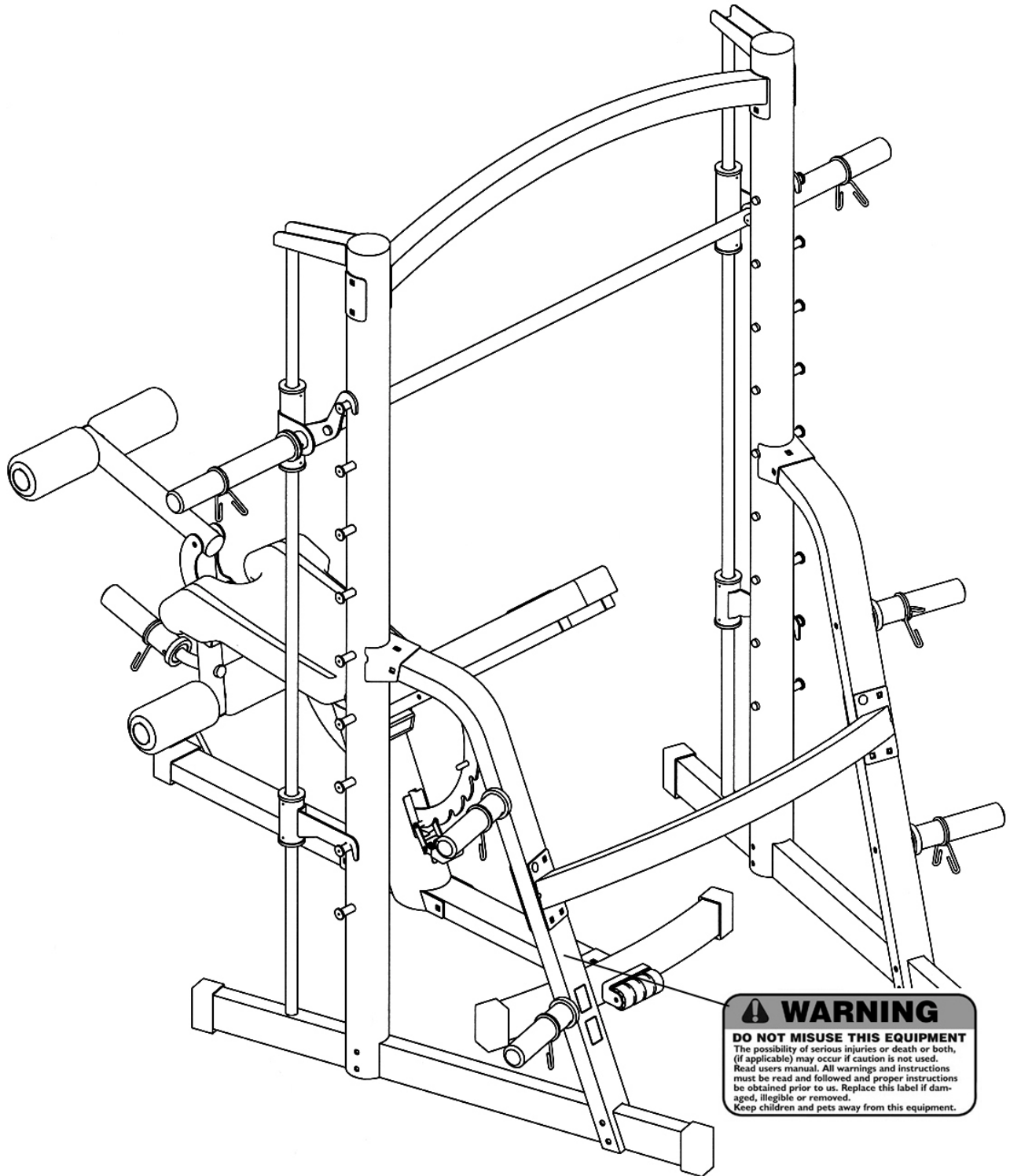

The warning label shown here has been placed on the back of Rear Support. If the label is missing or illegible, please call customer service at 1-800-888-8899 for replacements. Apply the label in the location shown.

SMITH MACHINE HARDWARE PACK

NOTE: The following parts are not drawn to scale. Please use your own ruler to measure the size.

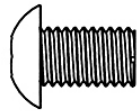

#34 M10 x $\frac{5}{8}$ " Allen Bolt (Qty 2)

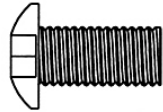

#33 M10 x $\frac{3}{4}$ " Allen Bolt (Qty 8)

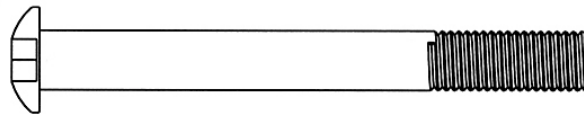

#32 M10 x $3 \frac{1}{2}$ " Allen Bolt (Qty 4)

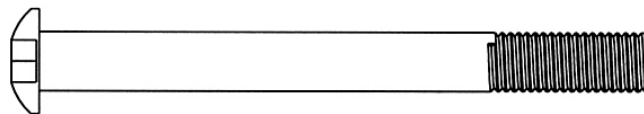

#31 M10 x 4" Allen Bolt (Qty 4)

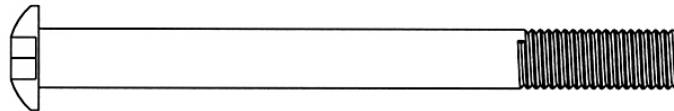

#30 M10 x $4 \frac{1}{8}$ " Allen Bolt (Qty 2)



#38 M10 Aircraft Nut
(Qty 20)

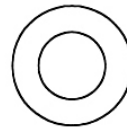

#37 $\varnothing \frac{3}{4}$ " Washer
(Qty 40)

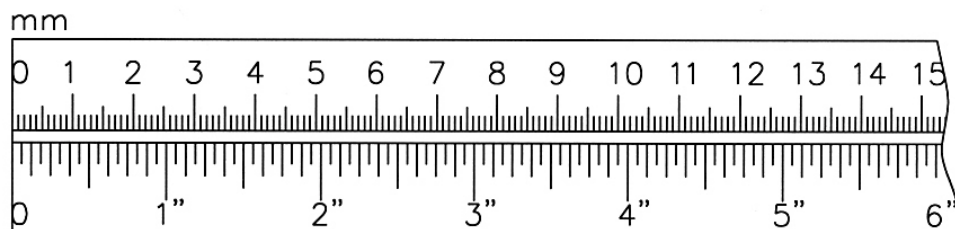

CAGE MACHINE HARDWARE PACK

NOTE: The following parts are not drawn to scale. Please use your own ruler to measure the size.

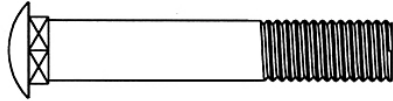

#27 M10 x 2 $\frac{3}{8}$ " Carriage Bolt
(Qty 8)

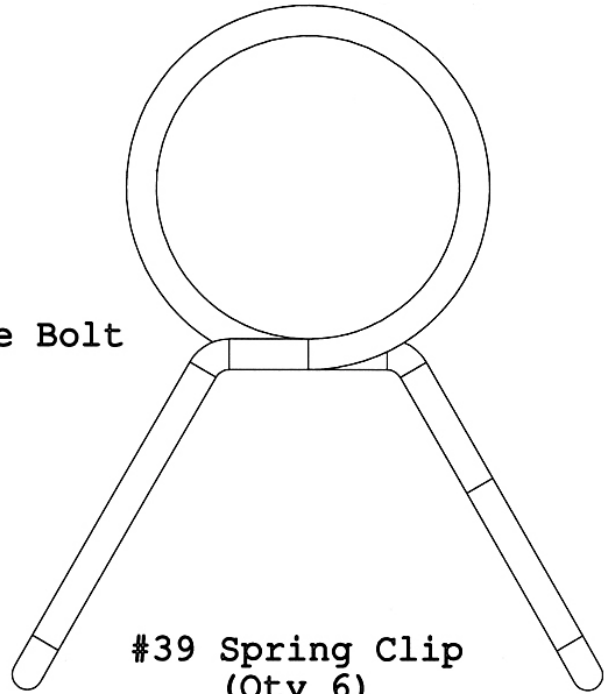

#39 Spring Clip
(Qty 6)

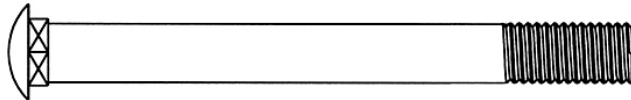

#28 M10 x 4" Carriage Bolt (Qty 2)

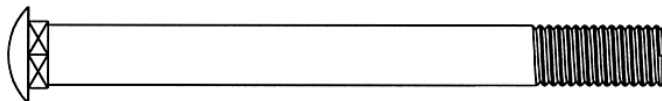

#29 M10 x 4 $\frac{1}{8}$ " Carriage Bolt (Qty 2)

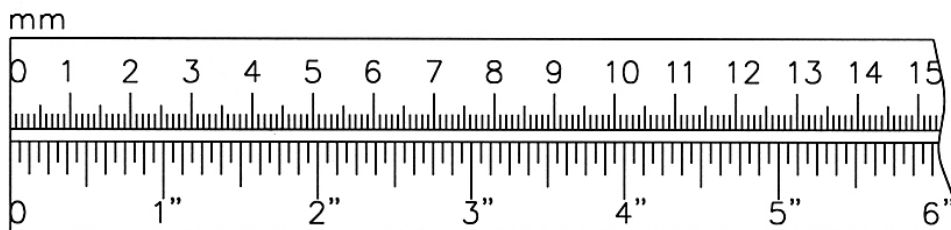

SMITH MACHINE ASSEMBLY INSTRUCTION

Tools Required for Assembling the Machine: Two Adjustable Wrenches and Allen Wrenches.

NOTE: It is strongly recommended that two or more people assemble this machine to avoid possible injury.

STEP 1 (See Diagram 1)

- A.) **Note: Do not tighten the Nuts and Bolts until instructed to do so.**
- B.) Attach the Left Rear Support (#5) onto a Base Frame (#3). Secure it with two M10 x 3 1/2" Allen Bolts (#32), four Ø 3/4" Washers (#37), and two M10 Aircraft Nuts (#38). Repeat the same step to install the Right Rear Support (#6) onto the other Base Frame.
- C.) Connect the Left and Right Rear Support by the Cross Brace (#7). Secure each end of the Cross Brace to each Rear Support with four M10 x 2 3/8" Carriage Bolts (#27), one 5 7/8" x 3 1/8" Bracket (#16), four Ø 3/4" Washers (#37), and four M10 Aircraft Nuts (#38).

DIAGRAM 1

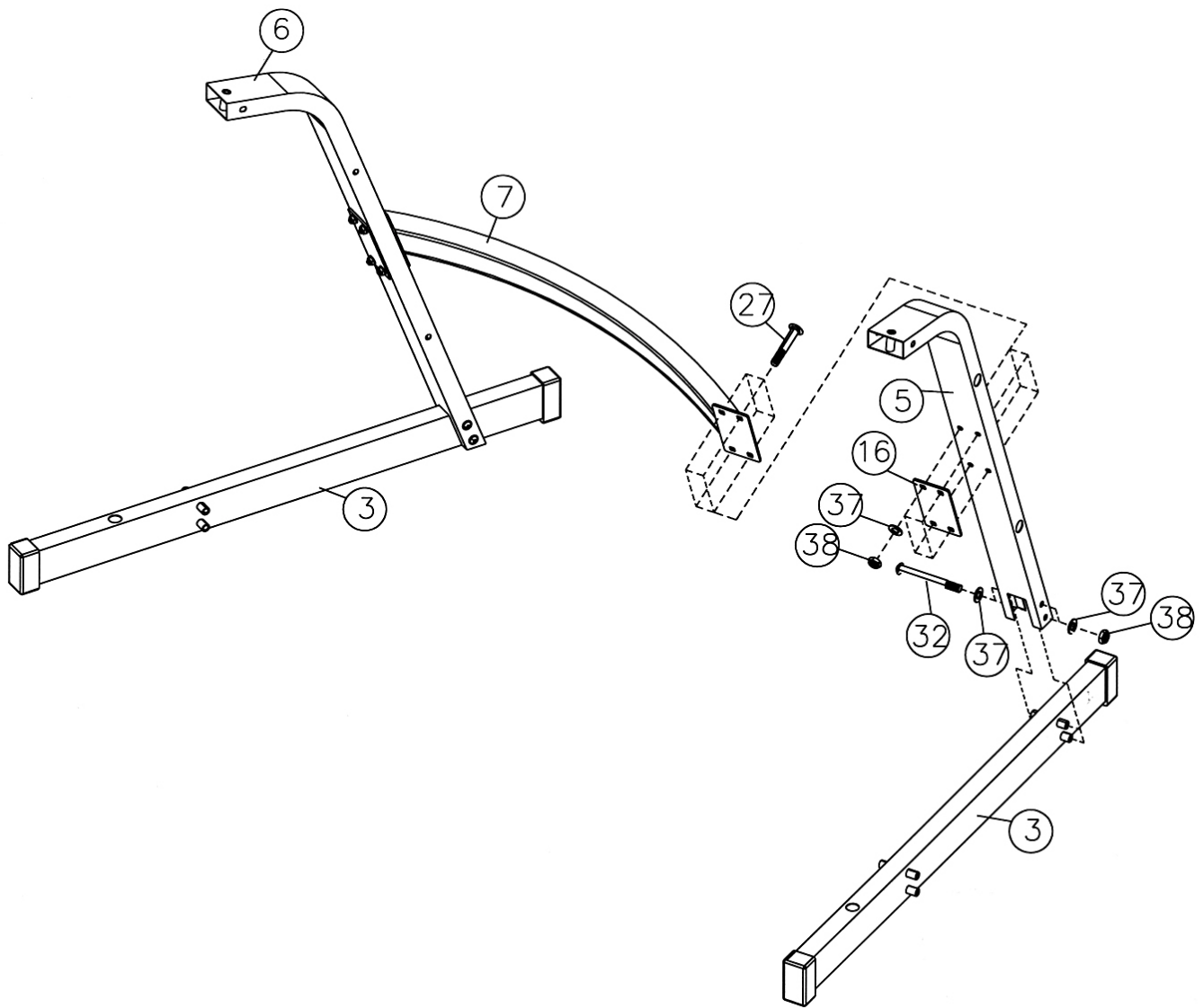

STEP 2 (See Diagram 2)

- A.) **Do not tighten Nuts and Bolts until instructed to do so.**

- B.) Attach the Left Upright Beam (#1) to the Left Rear Support (#5) and the left Base Frame (#3).
- C.) Secure it to the Base Frame with two M10 x 4" Allen Bolts (#31), four $\text{\O} \frac{3}{4}$ " Washers (#37), and two M10 Aircraft Nuts (#38).
- D.) Secure it to the Left Rear Support with one M10 x 4" Carriage Bolt (#28), one $\text{\O} \frac{3}{4}$ " Washer (#37), and one M10 Aircraft Nut (#38) from the side. Secure with one M10 x 5/8" Allen Bolt (#34) and one $\text{\O} \frac{3}{4}$ " Washer (#37) from the top.
- E.) Repeat A to D to install the Right Upright Beam (#2).
- F.) Attach the Top Beam (#4) to the Left & Right Upright Beam. Secure each end of the Top Beam to each Upright Beam with one 4" x 2 3/8" Curved Bracket (#15), one M10 x 4 1/8" Allen Bolt (#30) and one $\text{\O} \frac{3}{4}$ " Washer (#37) to the upper hole, one M10 x 4 1/8" Carriage Bolt (#29), one $\text{\O} \frac{3}{4}$ " Washers (#37), and one M10 Aircraft Nut (#38) to the lower hole.
- G.) Slide Lower Left Safety Stop Frame (#9) onto a Guide Rod (#11). Slide one Safety Stop Frame (#14) onto the Guide Rod. Insert the bottom of the Guide Rod into the hole on the left Base Frame. Attach the top of the Guide Rod to the bracket on Left Upright Beam. Secure each end of Guide Rod with one M10 x $\frac{3}{4}$ " (#33) and one $\text{\O} \frac{3}{4}$ " Washer (#37). Repeat the same step to install the Lower Right Safety Stop Frame (#10), the other Safety Stop Frame, and the other Guide Rod to the other side.
- H.) Turn and attach the hooks on the Lower Left & Right Safety Stop Frame to the selected slot on Left & Right Upright Beam (#1 & #2).
- I.) **Securely tighten all Nuts and Bolts installed in Step-1 and Step-2.**

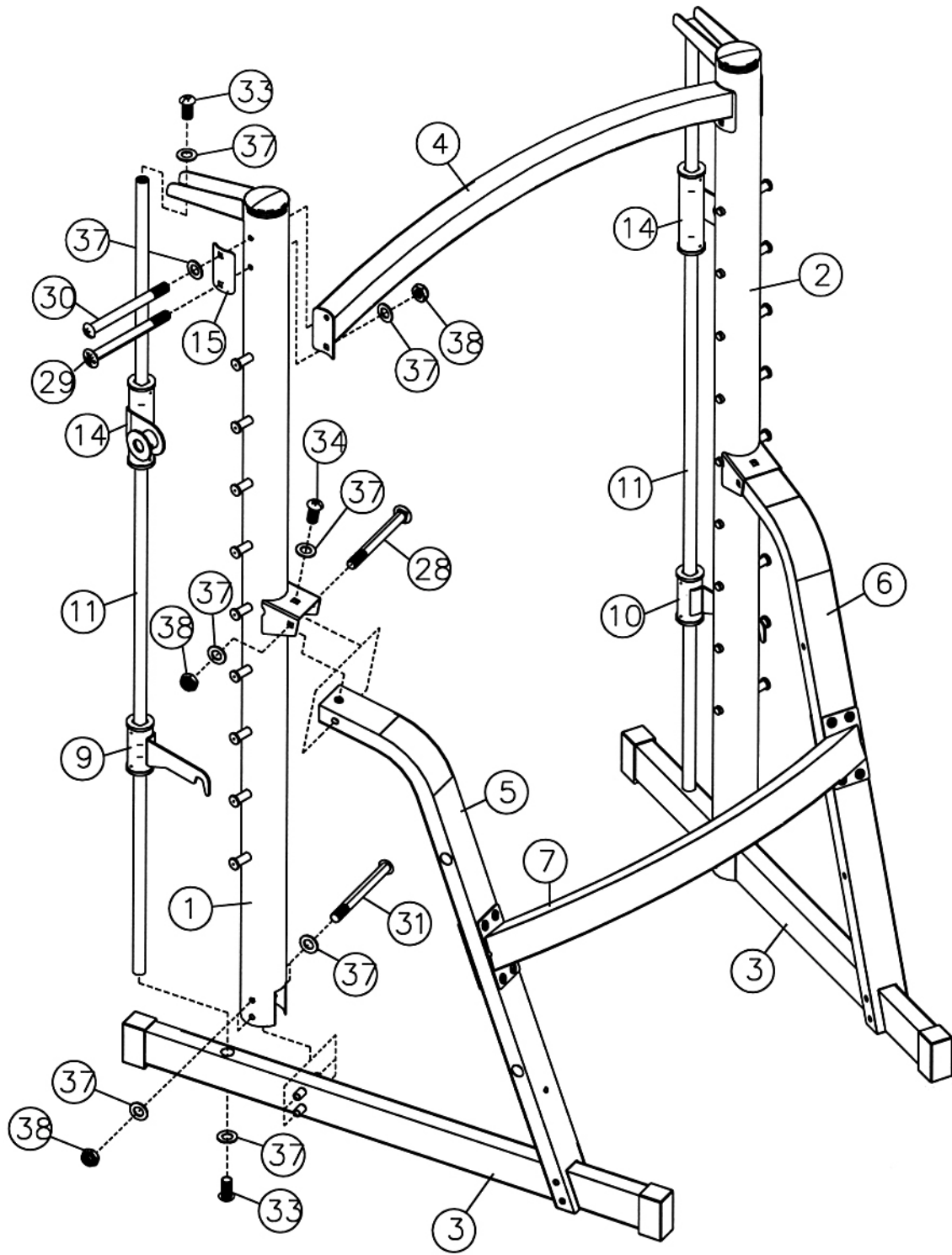

STEP 3 (See Diagram 3)

A.) Place the Lifting Sleeve (#8) in between the two Safety Stop Frames (#14). Align the

holes; insert the Weight Bar (#13) from outside of one Safety Stop Frame through the Lifting Sleeve to the other Safety Stop Frame on the other side.

- B.) Turn and attach the two safety catch hooks on the Lifting Sleeve (#8) to the selected pegs on the Left and Right Upright Beams (#1 & #2).
- C.) Attach two Weight Bar Sleeves (#26) onto the Weight Bar from both ends. Attach two Spring Clips (#39) to the Sleeves.
- D.) Attach four Weight Posts (#12) into the holes on Left & Right Rear Support (#5 & #6). Secure each Weight Post to the Support with one M10 x 3/4" Allen Bolt (#33) and one Ø 3/4" Washer (#77). Slide four Olympic Sleeves (#25) to the four Weight Posts. Attach four Spring Clips to the Sleeves.

DIAGRAM 3

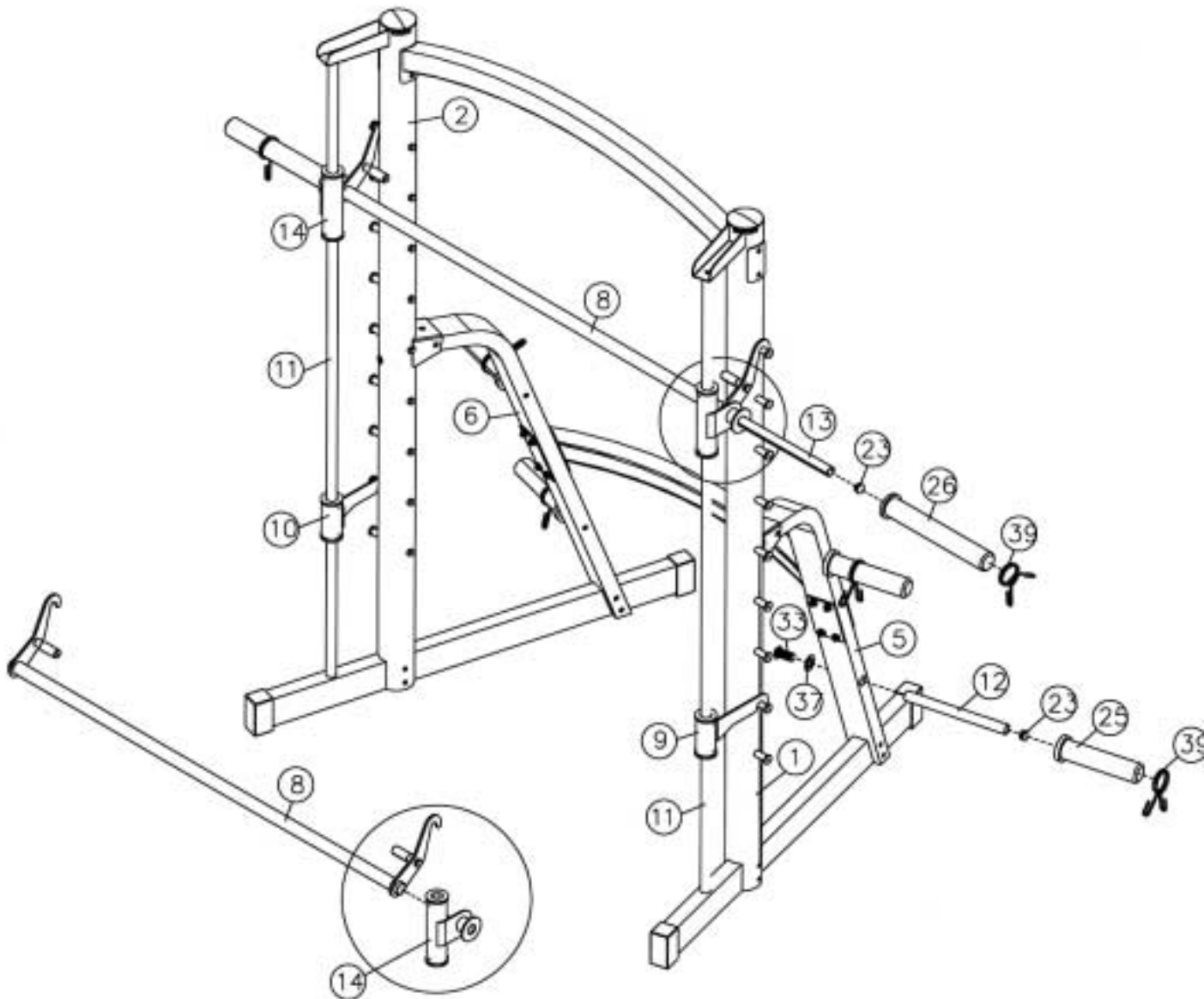

SMITH MACHINE EXPLODED DIAGRAM

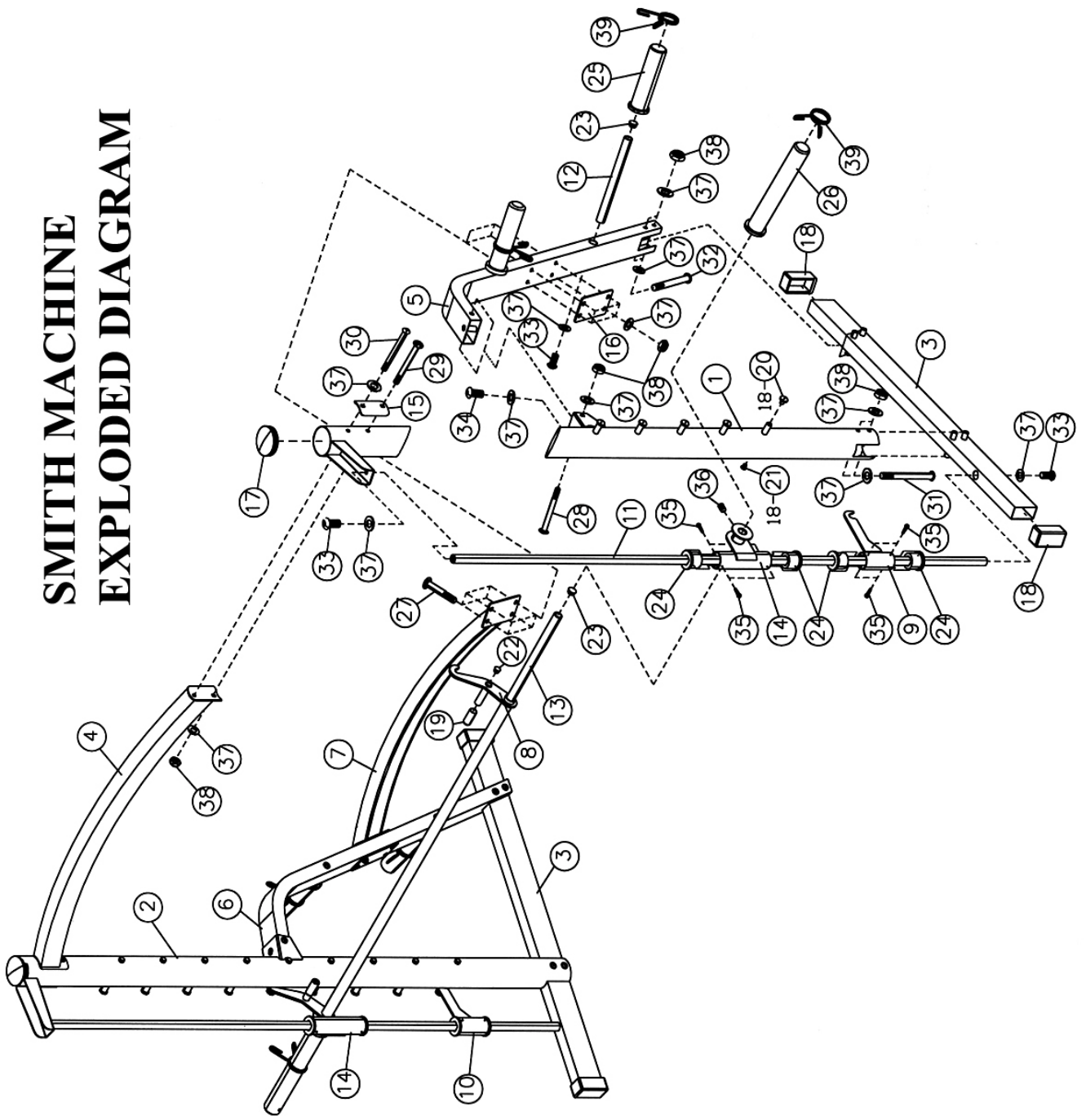

SMITH MACHINE PART LIST

KEY NO.	DESCRIPTION	Q'ty
1	Left Upright Beam	1
2	Right Upright Beam	1
3	Base Frame	2
4	Top Beam	1
5	Left Rear Support	1
6	Right Rear Support	1
7	Cross Brace	1
8	Lifting Sleeve	1
9	Lower Left Safety Stop Frame	1
10	Lower Right Safety Stop Frame	1
11	Guide Rod	2
12	Weight Post	4
13	Weight Bar	1
14	Safety Stop Frame	2
15	4" x 2 3/8" Curved Bracket	2
16	5 7/8" x 3 1/8" Bracket	2
17	Ø 3 1/2" Upright Beam End Cap	2
18	1 5/8" x 3 1/8" End Cap	4
19	Ø 3/4" x 2" Cover	2
20	Ø 7/8" x 3/4" End Cap	18
21	Ø 5/8" End Cap	18
22	Ø 3/4" End Cap	2
23	Ø 1" End Cap	6
24	Ø Sliding Sleeve	8
25	Olympic Sleeve	4
26	Weight Bar Sleeve	2
27	M10 x 2 3/8" Carriage Bolt	8
28	M10 x 4" Carriage Bolt	2
29	M10 x 4 1/8" Carriage Bolt	2
30	M10 x 4 1/8" Allen Bolt	2
31	M10 x 4" Allen Bolt	4
32	M10 x 3 1/2" Allen Bolt	4
33	M10 x 3/4" Allen Bolt	8
34	M10 x 5/8" Allen Bolt	2
35	ST3.8 Philips Screw	16
36	M8 x 3/8" Allen Bolt	2
37	Ø 3/4" Washer	40
38	M10 Aircraft Nut	20
39	Spring Clip	6

BENCH HARDWARE PACK

NOTE: The following parts are not drawn to scale. Please use your own ruler to measure the size.



#34 M8 x 1 $\frac{5}{8}$ " Allen Bolt (Qty 12)

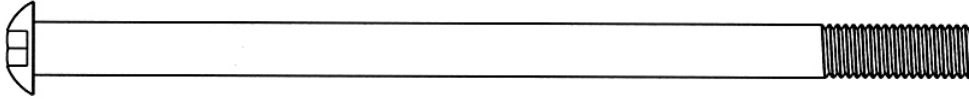

#35 M8 x 5 $\frac{1}{8}$ " Allen Bolt (Qty 1)

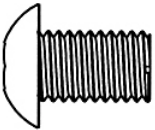

#36 M10 x $\frac{5}{8}$ " Allen Bolt (Qty 1)

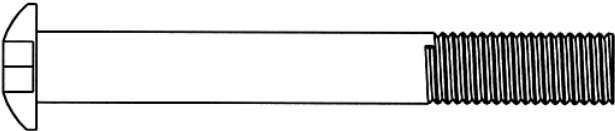

#38 M10 x 3 $\frac{1}{8}$ " Allen Bolt (Qty 1)

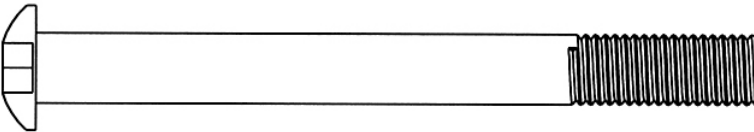

#40 M10 x 4" Allen Bolt (Qty 2)

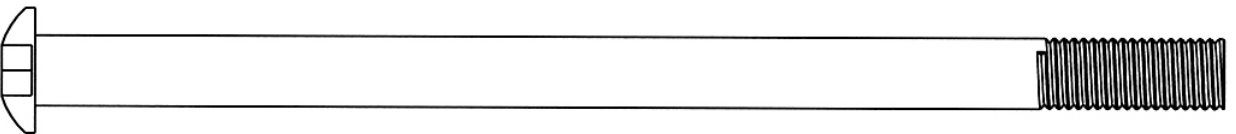

#39 M10 x 6 $\frac{1}{2}$ " Allen Bolt (Qty 1)

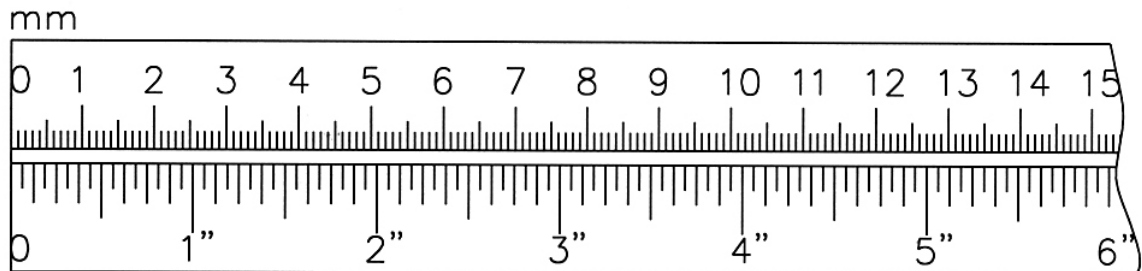

BENCH HARDWARE PACK

NOTE: The following parts are not drawn to scale. Please use your own ruler to measure the size.

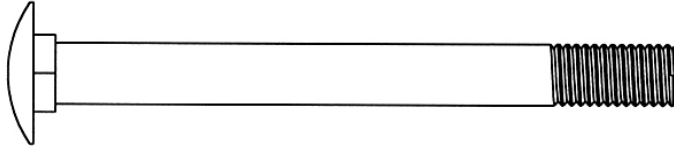

#41 M10 x 4" Carriage Bolt (Qty 5)

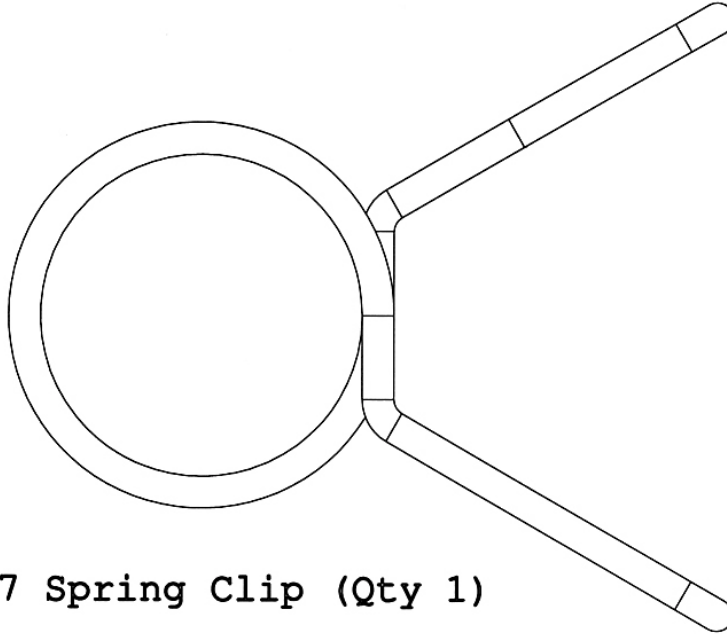

#27 Spring Clip (Qty 1)

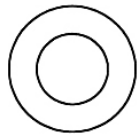

#31 $\text{\O} \frac{3}{4}$ " Washer
(Qty 14)

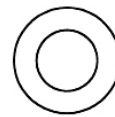

#30 $\text{\O} \frac{5}{8}$ " Washer
(Qty 18)

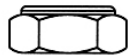

#33 M10 Aircraft Nut
(Qty 9)



#32 M8 Aircraft Nut
(Qty 5)

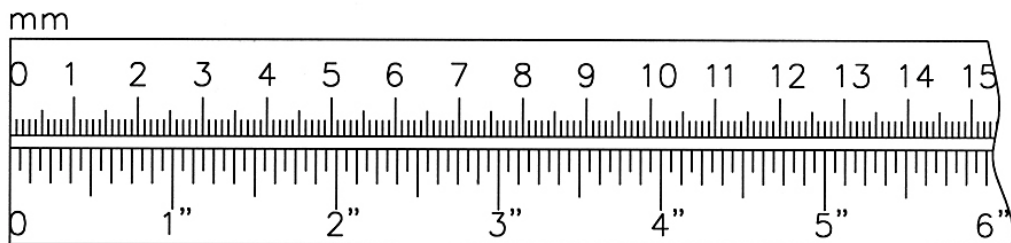

BENCH ASSEMBLY INSTRUCTION

STEP 1 (See Diagram 1)

- A.) Attach the Bench Base Frame (#6) to the Rear Stabilizer (#7). Secure the side-holes with two M10 x 4" Carriage Bolts (#41), two $\text{\O} \frac{3}{4}$ " Washers (#31), and two M10 Aircraft Nuts (#33). Secure the top hole with one M10 x $\frac{5}{8}$ " Allen Bolt (#36) and one $\text{\O} \frac{3}{4}$ " Washer (#31).
- B.) Attach the Wheel Set (#25) to the bracket on Rear Stabilizer. Secure it with one M8 x $5 \frac{1}{8}$ " Allen Bolt (#35), two $\text{\O} \frac{5}{8}$ " Washers (#30), and one M8 Aircraft Nut (#32).

DIAGRAM 1

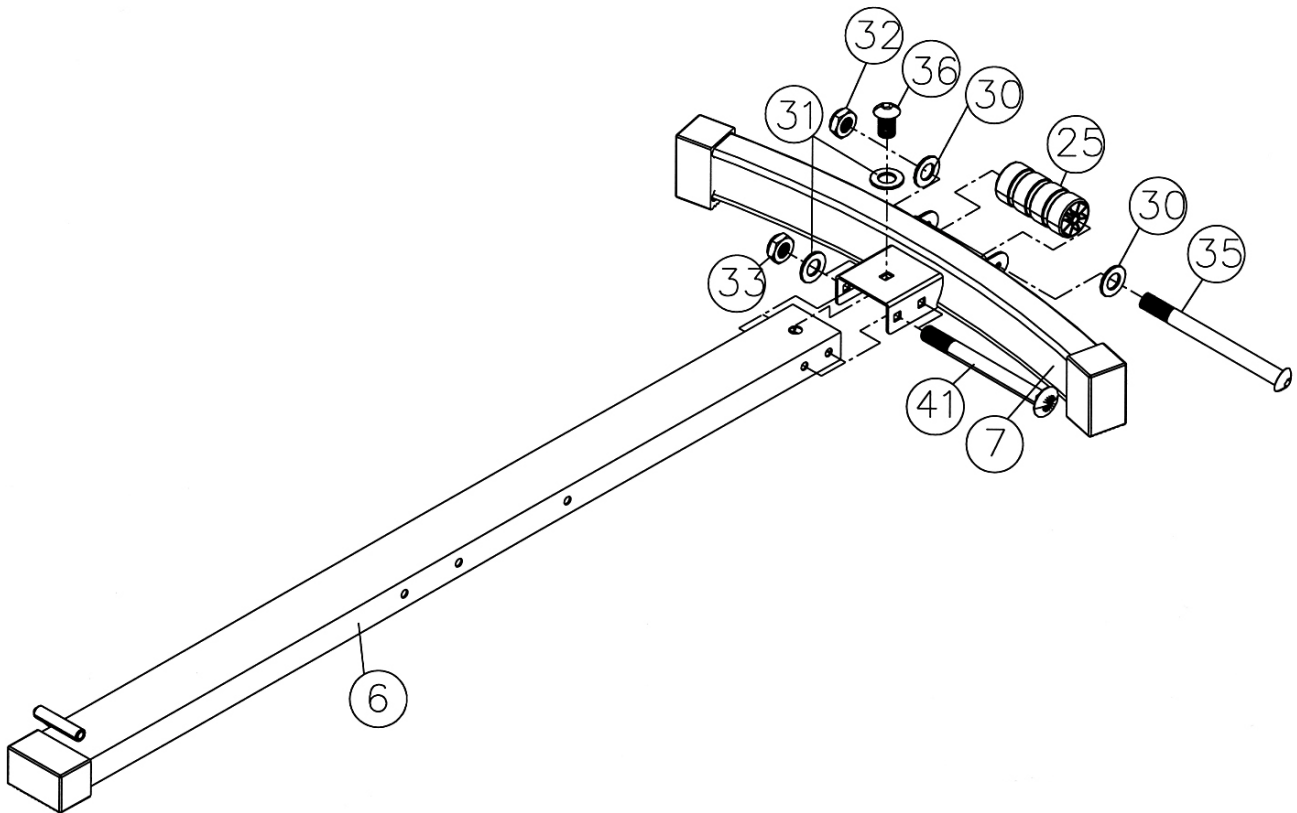

STEP 2 (See Diagram 2)

- A.) Attach the Main Seat Support (#1) to the Bench Base Frame (#6). Secure it with three M10 x 4" Carriage Bolts (#41), three $\text{\O} \frac{3}{4}$ " Washers (#31), and three M10 Aircraft Nuts (#33).
- B.) Attach the Front & Rear Seat Bracket (#4 & #5) to Main Seat Support. Secure each Bracket with one M10 x 4" Allen Bolt (#40), two $\text{\O} \frac{3}{4}$ " Washers (#31), and one M10 Aircraft Nut (#33).

DIAGRAM 2

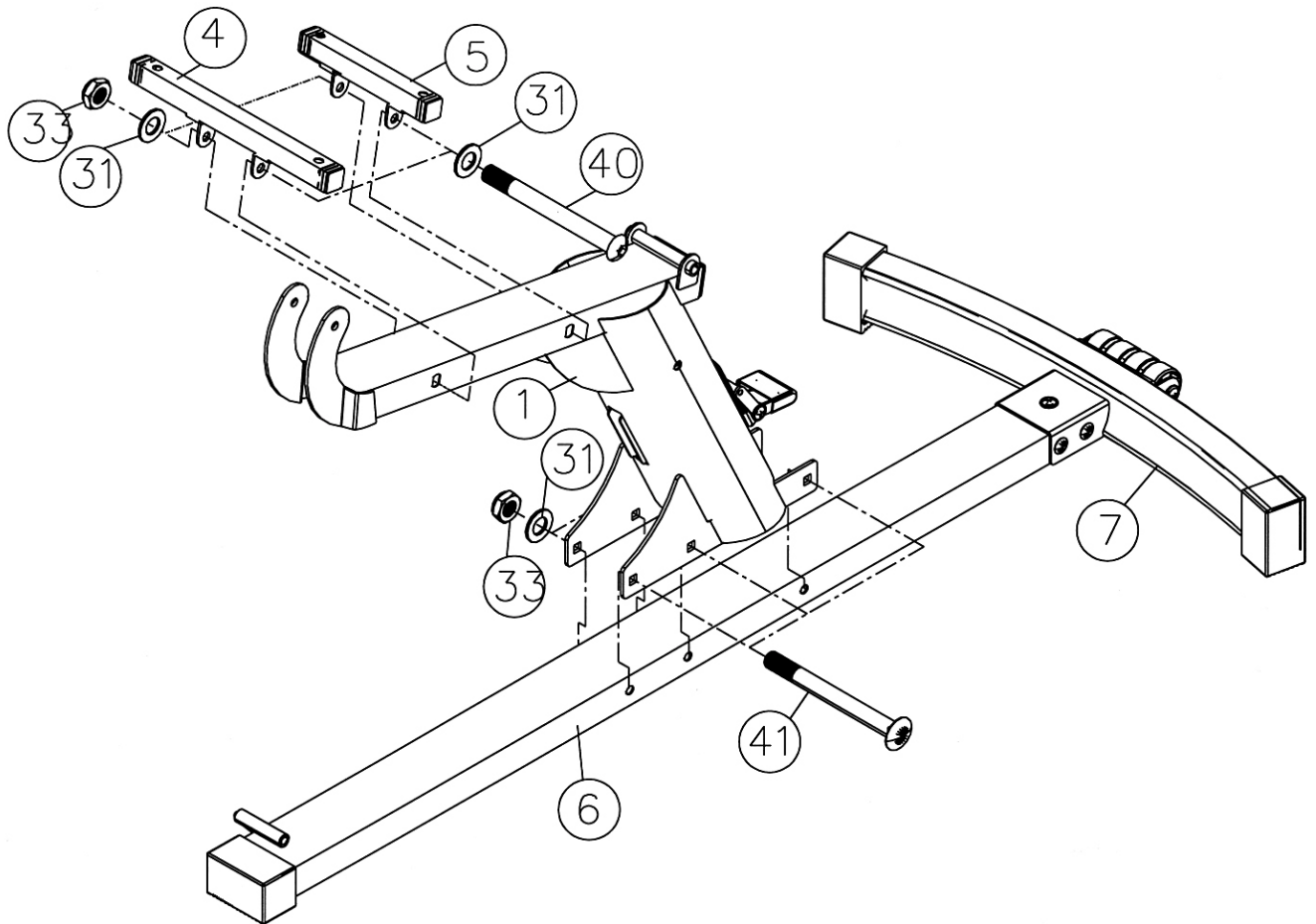

STEP 3 (See Diagram 3)

- A.) Align the bracket on the Backrest Adjustment Support (#8) in between the two Backrest Supports (#3). Secure it with four M8 x 1 5/8" Allen Bolts (#34), eight Ø 5/8" Washers (#30), and four M8 Aircraft Nuts (#32). **Do not tighten the Nuts and Bolts yet.**
- B.) Insert the Backrest Adjustment Support into the opening on the Main Seat Support (#1). Press or step down on the Backrest Adjustment Lever (#9) to allow the Support to go through.
- C.) Attach the bottom side-holes on the two Backrest Supports to the pivot on the Main Seat Support. Secure it with one M10 x 6 1/2" Allen Bolt (#39), two Ø 3/4" Washers (#31), and one M10 Aircraft Nut (#33).
- D.) **Securely tighten all Nuts and Bolts in B & C.**
- E.) **Do not over tighten the Nut and Bolt in C.**
- F.) **Make sure the Backrest Supports are able to swivel.**

DIAGRAM 3

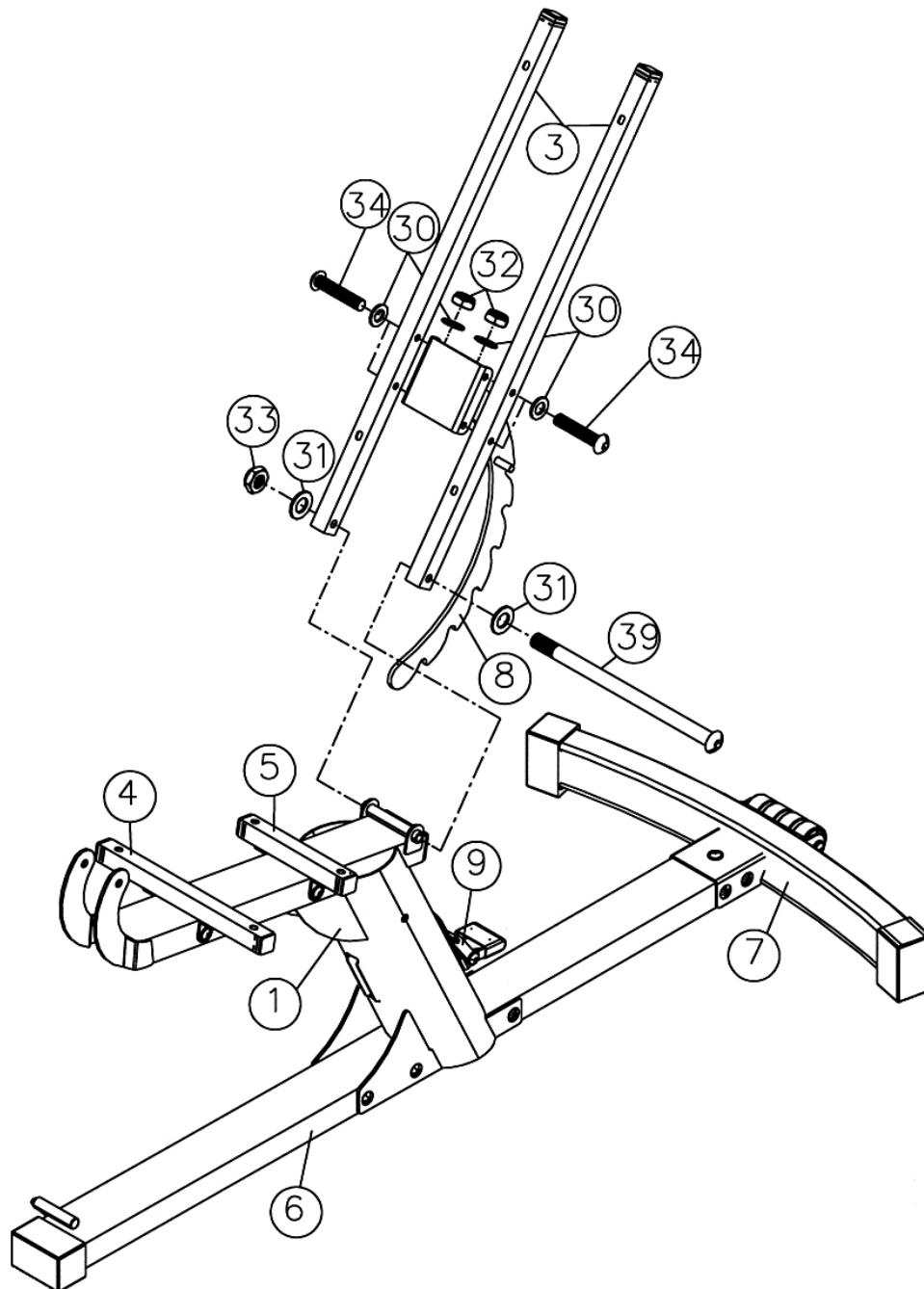

STEP 4 (See Diagram 4)

- A.) Attach the Backrest Board (#13) to the Backrest Supports (#3). Secure it with four M8 x 1 5/8" Allen Bolts (#34) and four Ø 5/8" Washers (#30).
- B.) Attach the Seat Pad (#12) to Front & Rear Seat Bracket (#4 & #5). Secure them with four M8 x 1 5/8" Allen Bolts (#34) and four Ø 5/8" Washers (#30).
- C.) Pull up the Backrest Adjustment Support (#8) or press down the Backrest Adjustment Lever (#9) to adjust the Backrest incline position.

DIAGRAM 4

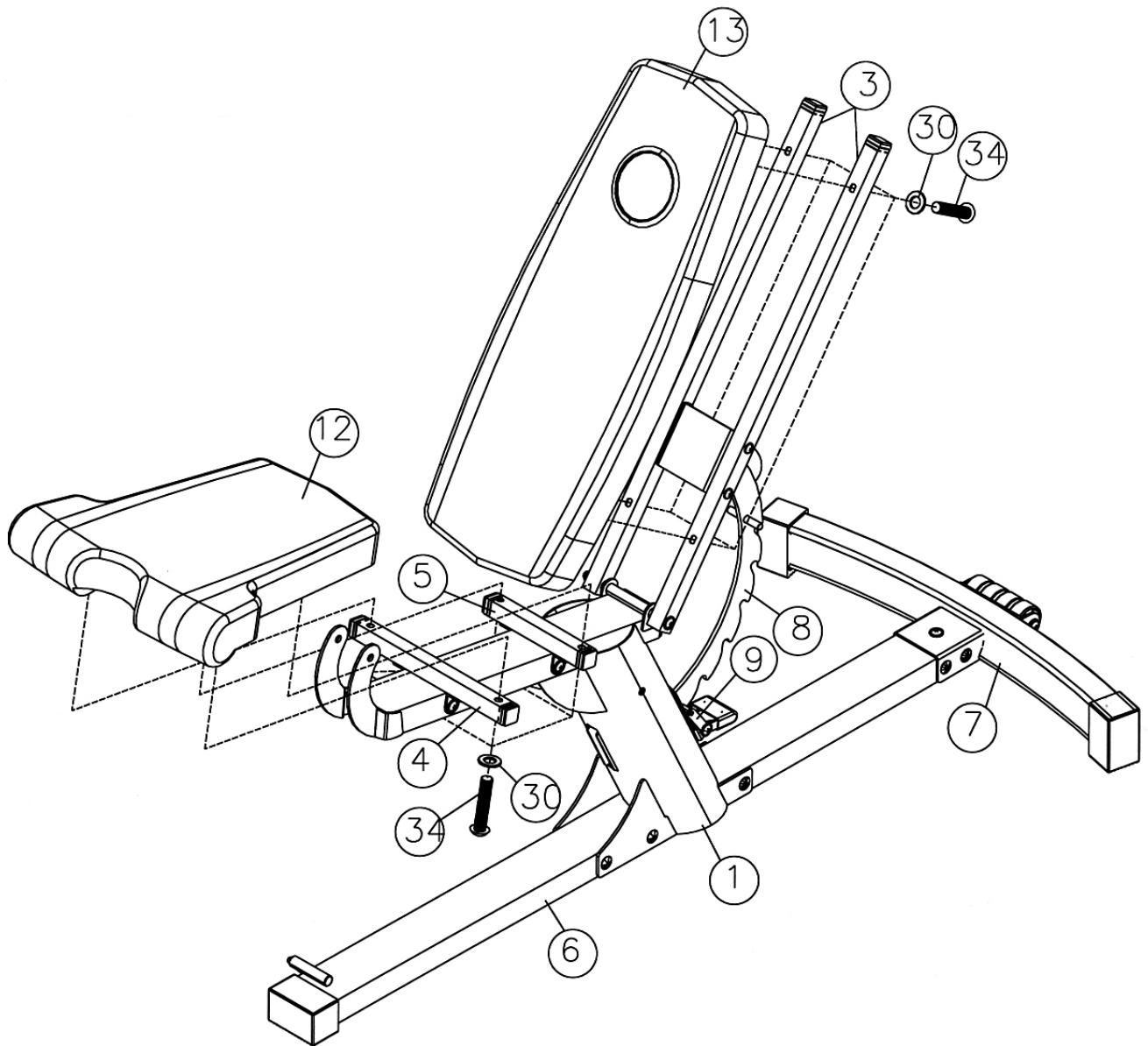

STEP 5 (See Diagram 5)

- A.) Attach the Leg Developer (#2) to Main Seat Support (#1). Secure it with one M10 x 3 1/8" Allen Bolt (#38), two Ø 3/4" Washers (#31), and one M10 Aircraft Nut (#33).
- B.) Insert two Foam Tubes (#10) halfway through the holes on Leg Developer. Push four Foam Rolls (#16) onto the Tubes from both ends. Plug four Foam Roll End Caps (#17) into the ends.
- C.) Slide an Olympic Sleeve (#28) on the weight post on Leg Developer. Attach a Spring Clip (#27) to the Sleeve.

DIAGRAM 5

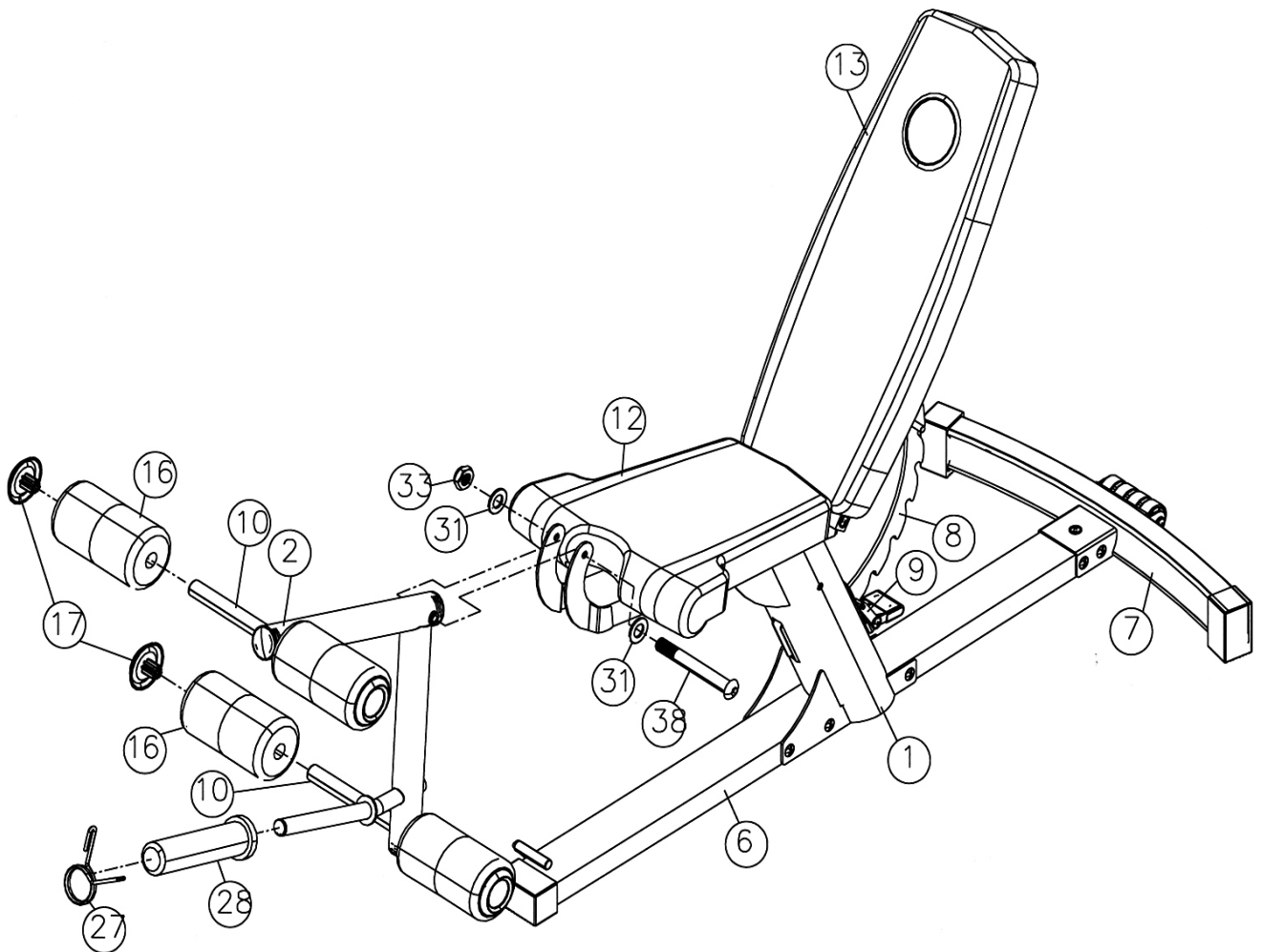

BENCH EXPLODED DIAGRAM

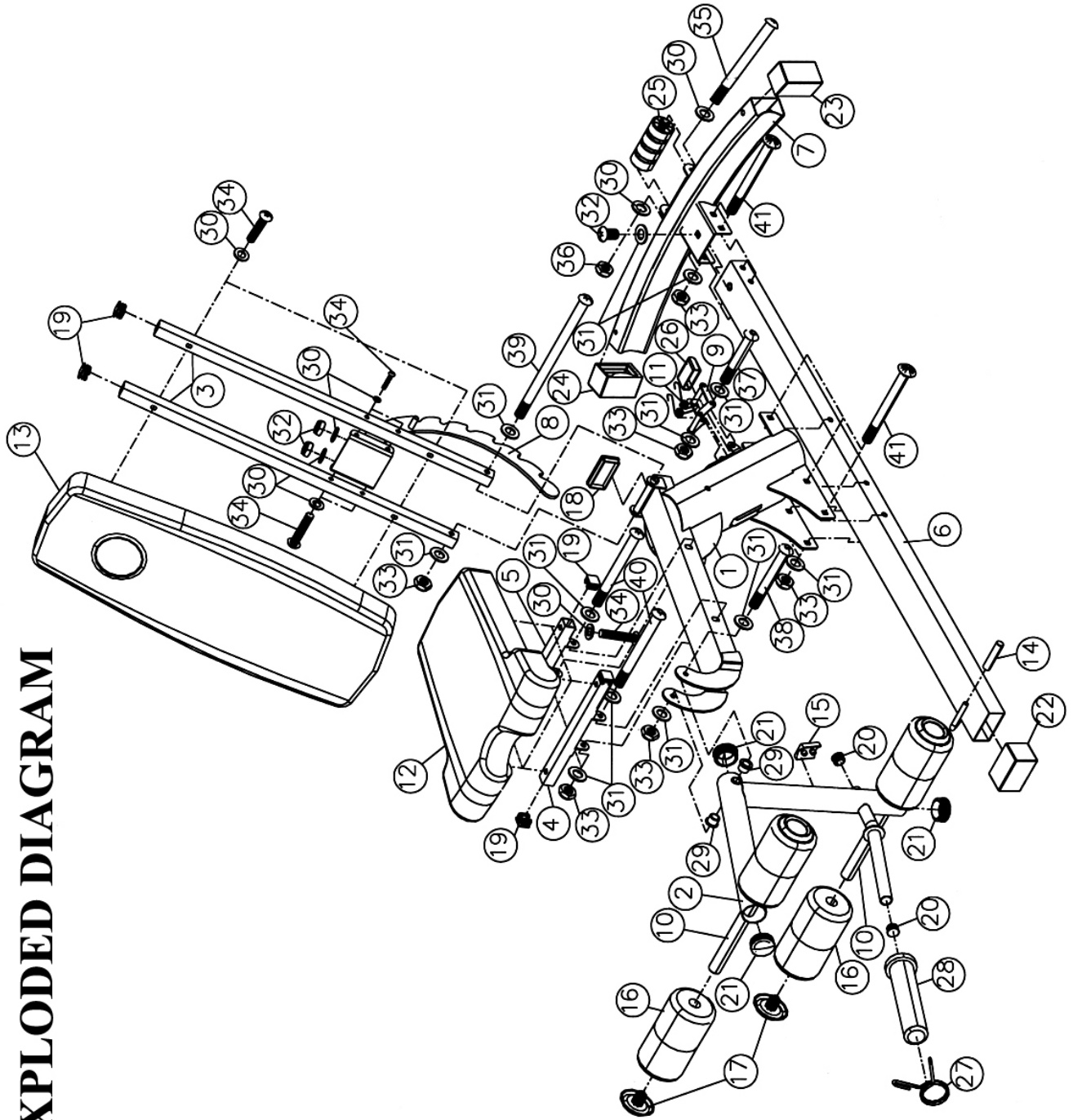

BENCH PARTS LIST

KEY NO.	DESCRIPTION	Q'ty
1	Main Seat Support	1
2	Leg Developer	1
3	Backrest Support	2
4	Front Seat Bracket	1
5	Rear Seat Bracket	1
6	Bench Base Frame	1
7	Rear Stabilizer	1
8	Backrest Adjustment Support	1
9	Backrest Adjustment Lever	1
10	Foam Tube	2
11	Spring	1
12	Seat Pad	1
13	Backrest Board	1
14	2 ¾" Grip	1
15	2" x 1 5/8" Rubber Bumper	1
16	Foam Roll	4
17	Foam Roll End Cap	4
18	1 5/8" x 3 1/8" End Cap	1
19	1" Square End Cap	6
20	Ø 1" End Cap	2
21	Ø 2" End Cap	3
22	Base Frame End Cap	1
23	Rear Stabilizer Left End Cap	1
24	Rear Stabilizer Right End Cap	1
25	Wheel Set	1
26	Lever Cover	1
27	Spring Clip	1
28	Olympic Sleeve	1
29	Ø ¾" Leg Developer Bushing	2
30	Ø 5/8" Washer	18
31	Ø ¾" Washer	16
32	M8 Aircraft Nut	5
33	M10 Aircraft Nut	10
34	M8 x 1 5/8" Allen Bolt	12
35	M8 x 5 1/8" Allen Bolt	1
36	M10 x 5/8" Allen Bolt	1
37	M10 x 2 ½" Allen Bolt	1
38	M10 x 3 1/8" Allen Bolt	1
39	M10 x 6 ½" Allen Bolt	1
40	M10 x 4" Allen Bolt	2
41	M10 x 4" Carriage Bolt	5

IMPEX[®] INC.

LIMITED WARRANTY

IMPEX Inc. ("IMPEX[®]") warrants this product to be free from defects in workmanship and material, under normal use and service conditions, for a period of two years on the Frame from the date of purchase. This warranty extends only to the original purchaser. IMPEX's obligation under this Warranty is limited to replacing or repairing, at IMPEX's option.

All returns must be pre-authorized by IMPEX. Pre-authorization may be obtained by calling IMPEX Customer Service Department at 1-800-999-8899. All freights on products returned to IMPEX must be prepaid by the customer. This warranty does not extend to any product or damage to a product caused by or attributable to freight damage, abuse, misuse, improper or abnormal usage or repairs not provided by an IMPEX authorized service center or for products used for commercial or rental purposes. No other warranty beyond that specifically set forth above is authorized by IMPEX.

IMPEX is not responsible or liable for indirect, special or consequential damages arising out of or in connection with the use or performance of the product or other damages with respect to any economic loss, loss of property, loss of revenues or profits, loss of enjoyments or use, costs of removal, installation or other consequential damages or whatsoever natures. Some states do not allow the exclusion or limitation of incidental or consequential damages. Accordingly, the above limitation may not apply to you.

The warranty extended hereunder is in lieu of any and all other warranties and any implied warranties of merchantability or fitness for a particular purpose is limited in its scope and duration to the terms set forth herein. Some states do not allow limitations on how long an implied warranty lasts. Accordingly, the above limitation may not apply to you.

This warranty gives you specific legal right. You may also have other rights which vary from state to state. Register on-line at www.impex-fitness.com

IMPEX[®] INC.
14777 Don Julian
City of Industry, CA 91746

ORDERING REPLACEMENT PARTS

Replacement parts can be ordered by calling our Customer Service Department toll-free at **1-800-999-8899** during our regular business hours: Monday through Friday, 9 am until 5 pm Pacific standard time.

info@impex-fitness.com

When ordering replacement parts, always give the following information.

1. Model
2. Description of Parts
3. Part Number
4. Date of Purchase