



UHF Gen 2 RFID Speedway®/Revolution

Installation and Operations Guide



SPEEDWAY®
REVOLUTION

Speedway Revolution Installation and Operations Guide

Products Covered by this Guide

This guide pertains to readers that have the following part numbers:

Speedway R220 (FCC): **IPJ-REV-R220-USA1M1**

Speedway R420 (FCC): **IPJ-REV-R420-USA1M1**



Federal Communications Commission (FCC) Compliance

This equipment has been tested and found to comply with the limits for a Class B digital device, pursuant to Part 15 of the FCC Rules. These limits are designed to provide reasonable protection against harmful interference in a commercial environment. This equipment generates, uses, and can radiate radio frequency energy and, if not installed and used in accordance with the instructions, may cause harmful interference to radio communications. However, there is no guarantee that interference will not occur in a particular installation. If this equipment does cause harmful interference to radio or television reception, which can be determined by turning the equipment off and on, the user is encouraged to try to correct the interference by one or more of the following measures:

- Reorient or relocate the receiving antenna.
- Increase the separation between the equipment and receiver.
- Consult the dealer or a qualified radio/TV technician for assistance.

Caution

Changes to this product or modifications not expressly approved by the party responsible for compliance could void the user's authority to operate per FCC Part 15.



Industry Canada (IC) Compliance

Operation is subject to the following two conditions: (1) this device may not cause interference and (2) this device must accept any interference, including interference that may cause undesired operation of the device. This device has been designed to operate with the antenna(s) listed on page 20 that have a maximum gain of 6 dB. Antennas not included in this list or having a gain greater than 6 dB are strictly prohibited for use with this device. The required antenna impedance is 50 ohms. To reduce potential radio interference to other users, the antenna type and its gain should be so chosen that the equivalent isotropically radiated power (EIRP) is not more than that permitted for successful communication. The term "IC:" before the radio certification number only signifies that Industry of Canada technical specifications were met.



Warning

Before You Begin

Please read this document in its entirety before operating the Speedway/Revolution reader, as serious personal injury or equipment damage may result from improper use. Unauthorized opening of the Speedway/Revolution reader enclosure voids the warranty.

To safeguard personnel, be sure to position all antenna(s) according to the specified requirements for your regulatory region. For details, see "Appendix A: Information Specific to Regions of Operation" on page 19.

Table of Contents

Chapter 1: Introduction	1
About This Guide	1
Intended Audience	1
Other Documents of Interest	1
Impinj Support Information	2
Introduction to Speedway®/Revolution	2
Requirements for Using Speedway/R	2
Environmental Requirements	2
Hardware Requirements	3
Power Requirements	3
Supported Operating Environments	3
Supported Communication Protocol	4
Antenna Requirements	4
Chapter 2: Installing and Connecting Speedway/Revolution	5
Speedway/R I/O Ports and Status LEDs	5
Antenna Ports and Status LEDs	5
Overview of Installation and Connection Process	7
Detailed Installation Procedures	7
Step 1: Position the Speedway/R reader	7
Mounting the Reader	7
Step 2: Connect the Antenna(s) to the Speedway/R Reader	8
Step 3: Connect Speedway/R to the Network	8
Step 4: Power the Reader	11
Step 5: Use the MultiReader Application to Read Some Tags	11
Chapter 3: Configuring Speedway/Revolution	13
Configuration Overview	13
Using Rshell to Configure Network Settings for Speedway/R	13
Configuring the RFID Behavior of Speedway/R	13
Chapter 4: Monitoring Speedway/Revolution	15
Using Rshell to Monitor Speedway/R	15
Viewing Speedway/R Logs	15
Chapter 5: Troubleshooting	17
Appendix A: Information Specific to Regions of Operation	19
Operation in North America	19
Frequency Plan	19
Antenna Requirements	19
Positioning	19
Installation	20
Power	20
Approved Antenna Vendors	20
Appendix B: GPIO Details	23

Chapter 1: Introduction

Welcome to the *Speedway/Revolution Installation and Operations Guide*.

About This Guide

This guide provides detailed instructions on installing, connecting, configuring, operating, upgrading, and troubleshooting Speedway/Revolution. To minimize and streamline the information in this guide, its contents focus on the installation and operations of a single reader. For information about performing more complex installations and configurations (for example, installing and configuring large numbers of readers), see the *Impinj System Design Guide*.

Note: From this point forward, Speedway/Revolution will be expressed as Speedway/R.

Intended Audience

This guide is intended for anyone who is installing a Speedway/R reader. The assumption, however, is that the primary users of this guide are systems engineers and IT personnel who have basic knowledge of and experience working in software development, hardware systems integration, and network connectivity.

In addition, it is assumed that the reader has a high-level understanding of RFID and RFID systems management as well as a basic familiarity with the EPCGlobal Gen 2 specification. To learn more about RFID and the Gen 2 specification, see the *Impinj System Design Guide*.

Other Documents of Interest

This guide is part of a larger documentation set that supports Speedway/R. The other documents are outlined below:

- *Speedway/Revolution Quick Start Guide*
This one-page guide is included in the box with the Speedway/R hardware. It provides basic information about the hardware as well as pointers to additional documentation and downloads of firmware upgrades and other support software.
- *Impinj System Design Guide*
This guide, intended for systems and software engineers, is designed to help you make informed decisions about the RFID system you are creating and integrating into your environment. It provides background information on RFID, suggestions and instructions for performing large-scale installations and upgrades, suggested solutions for specific scenarios and environments, and a myriad of suggestions and best practices to use with your RFID system.
- *Speedway/Revolution Programmer's Guide*
This guide, intended for software engineers, provides guidelines and best practices for working with the LLRP Toolkit. In addition to this guide, software engineers have access to language-specific reference guides and sample applications illustrating the scenarios discussed in the Programmer's Guide.
- *Rshell Reference Guide*
This guide, intended for anyone who needs to use the Speedway/R Rshell console, includes descriptions and syntax for the Rshell command language.

Impinj Support Information

See the Impinj Support Web page (support.impinj.com) for information on obtaining technical assistance. See “Chapter 5: Troubleshooting” on page 17 for guidelines on how to capture data for analysis by Impinj technical support personnel.

Introduction to Speedway®/Revolution

Speedway®/Revolution (or Speedway/R) is a stationary, small form factor, UHF Gen 2 RFID tag reader that provides network connectivity between tag data and enterprise system software. Built on the industry-leading quality, high performance, and excellent reliability of Impinj’s original Speedway reader, Speedway/R includes a variety of new features that increase its application flexibility:



- **Low Power Consumption**

With a low power consumption design, Speedway/R can utilize Power over Ethernet (PoE).

Using PoE simplifies deployment and dramatically reduces costs. Speedway/R does not compromise on performance, however. Even when using PoE, the reader delivers the full 30 dBm transmit power. Note that Speedway/R supports the IEEE standard 802.3af (for PoE).

- **Compact Form Factor**

The compact size of Speedway/R (7.4 x 6.9 x 1.2 in) enables ease of installation in tight spaces and embedded applications.

- **Availability of Two Models**

Speedway/R offers two models, each with a different number of high performance monostatic antenna ports. The R220 model is a two-port configuration (shown in the above photograph), while the R420 is a four-port configuration.

- **High Performance Features**

Speedway/R utilizes a variety of high performance features making it possible to read up to 1150 tags per second. These features include Autoset, Low Duty Cycle, dynamic antenna switching, and receive sensitivity filtering for read zone confinement.

Requirements for Using Speedway/R

This section describes the key requirements for operating and interfacing with a Speedway/R reader.

Environmental Requirements

- Operating temperature: -20 degrees C to +50 degrees C (non-condensing)
- Supported Regions: US, Canada, and other regions following US FCC Part 15 regulations

Hardware Requirements

- TCP/IP network equipment, as required to connect the reader to a PC, Mac, or other network terminal. If you plan to use PoE, you must have either a power injector or a network switch that supports PoE.
- Impinj-approved UHF RFID antenna(s), including associating RF cable with RP-TNC male connector interface
- A computer running Microsoft Windows XP, Vista, or Linux PC, which has:
 - an available RS-232 serial port (required only if host system does not support DHCP)
 - Standard, grounded DB9 serial cable (required only if your system does not support IP provisioning). The Cisco Management Cable (RJ-45 to DB9) is recommended.
 - An Ethernet port
 - Standard Ethernet cable(s)

Power Requirements

As noted earlier, there are two options for powering your Speedway/R reader: Power-Over-Ethernet (PoE) or an external power supply. PoE offers the most efficient power consumption and allows up to +30 dBm. An external power supply allows up to +32.5 dBm.

If using a power supply module, you must use a module with +24 VDC output that has the following part number: **IPJ-A2001-000**. Use an AC power cord (for North America) that has the following part number: **IPJ-A2051-USA**. You can order this power supply and power cord from Impinj.

Supported Operating Environments

This section describes the environments in which you can access the Speedway/R Rshell console (for configuring, monitoring, and maintaining the reader). The tools you use to access the Rshell console depend on how you connect your PC to the reader: serial connection (RS-232) or Ethernet connection (SSH/Telnet). On PCs running Microsoft Windows, you can now use the same tool—Putty—for both types of connections.

Table 1: Speedway/R Operating Environments

Interface	Protocol	Recommended Tools	
		Microsoft Windows	Linux
Ethernet	SSH—Port 22 Telnet—Port 23	Putty	SSH or Telnet
Serial	RS-232	Putty (version 0.59 and higher supports serial)	Minicom

Supported Communication Protocol

For client control of the reader, Speedway/R supports the EPCglobal Low Level Reader Protocol (LLRP) v1.0.1. LLRP is an EPCglobal standard interface that allows communication with the reader and with EPCglobal Generation 2 (Gen 2) RFID tags.

Antenna Requirements

Depending on the reader model you are installing, Speedway/R is equipped with two (R220) or four (R420) monostatic antenna ports (independent, bidirectional, and full duplex TX/RX).

Antenna requirements vary by regulatory region. For details about the requirements in a specific region, see the relevant antenna section in “Appendix A: Information Specific to Regions of Operation” on page 19.

Chapter 2: Installing and Connecting Speedway/Revolution

This chapter provides details about the Speedway/R I/O ports and status LEDs and explains the detailed procedures for installing the reader and connecting it to your network.

Speedway/R I/O Ports and Status LEDs

The following graphic illustrates the various I/O ports located on the Speedway/R reader. This graphic illustrates a Speedway R420, which includes four antenna ports (not visible in this graphic). Note that Speedway R220 includes two antenna ports. Other than that difference, however, the exterior ports are the same on both models.

Figure 1: Impinj Speedway/R Port Connections

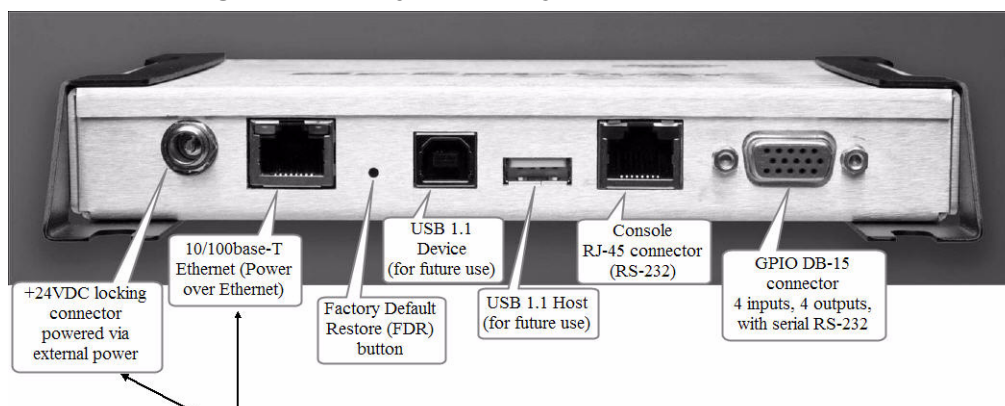

Note: Either of these power sources may be used. +24VDC power source is active only when an external power supply is used.

Note: For details on the function and electrical specifications for each pin of the GPIO DB-15 connector, see “Appendix B: GPIO Details” on page 23.

Antenna Ports and Status LEDs

On the back side of the reader are the antenna ports and LED status indicators. The following graphic (of an R220) illustrates their locations:

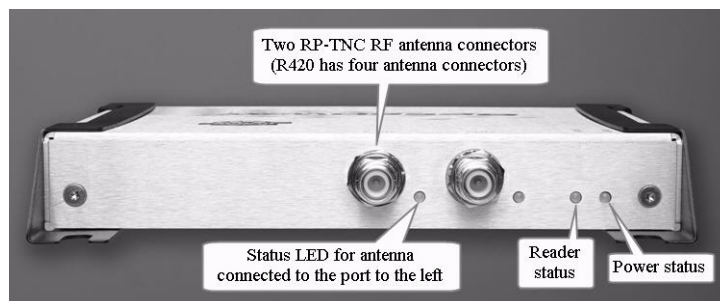

Chapter 2: Installing and Connecting Speedway/Revolution

The following table describes the LED behavior for various reader states:

Table 2: Reader Operations and Associated Status LED Behavior

Reader Operation		LED	Expected Behavior
Startup (power on), normal completion	Power applied, attempting to start boot code	Power	Solid red
		Status	Off
	Bootloader running	Power	Blinking green (1Hz)
		Status	Off
	Bootloader calling firm-ware image	Power	Solid green
		Status	Off
	Bootloader completed successfully, reader is ready	Power	Solid green
		Status	Solid green
Startup (reset), normal completion	Factory Default Restore (FDR) button pressed	Power	Turns off
		Status	Off
	FDR button pressed for 3 seconds	Power	Blinks twice (red), indicates a configuration default restore will occur
		Status	Off
Startup (failure)	Hardware problems detected, unable to boot	Power	Continuous blinking red
		Status	Off
Detection of antenna activity	Detects no activity on antenna port	Antenna	Off
	Detects antenna transmission activity on antenna port	Antenna	Solid green

Overview of Installation and Connection Process

Listed below are the primary steps to follow to install and connect Speedway/R:

1. Position the reader appropriately for your environment. This may or may not involve mounting the reader.
2. Connect the antenna(s) to the appropriate ports on the reader.
3. Connect the reader to the network.
4. Connect power to the reader.
5. Using the MultiReader application, read some tags with your newly-installed reader.

Detailed Installation Procedures

This section provides the details for each step listed above.

Step 1: Position the Speedway/R reader

Choose the appropriate location for the reader. Generally speaking, you should always keep the unit away from direct sunlight, high humidity, extreme temperatures, vibration, and sources of electromagnetic interference. Any combination of these conditions may degrade performance or shorten the life of the unit. Also, if you plan to power the reader using an external power supply, confirm that there is a standard 120 or 220 VAC outlet nearby. To minimize power loss, it is best to position the reader within 100 meters of its power source. To learn more about choosing the appropriate location for maximizing the performance and efficiency of your reader, see the *Impinj System Design Guide*.

Mounting the Reader

Depending on your environment, you may need to mount the reader to a wall or another object.

To mount the Speedway/R reader:

1. Locate the four mounting slots on the reader, as illustrated below:

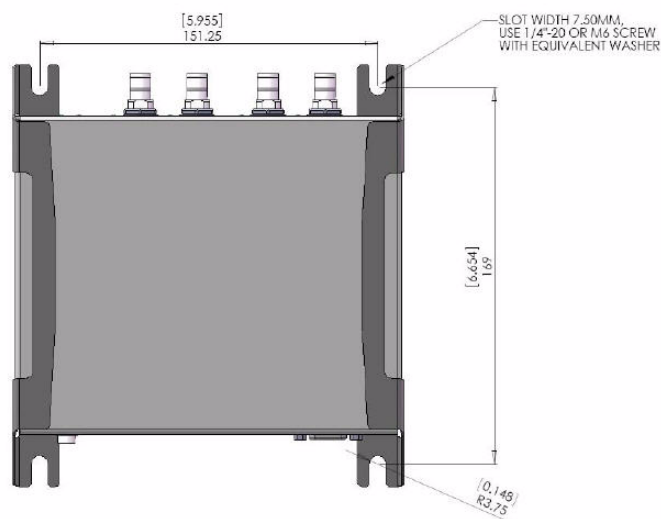

2. Using 1/4" - 20 or M6 screws, secure the unit. You can mount the reader horizontally or vertically.

Caution: If there is any chance of dust or water exposure, you should mount the reader so that digital I/O ports are facing down to prevent ingress.

Step 2: Connect the Antenna(s) to the Speedway/R Reader

Depending on the Speedway/R model you are installing, the reader has either two antenna ports (Speedway R220) or four antenna ports (Speedway R420). Each port is independent, bidirectional, and full duplex TX/RX (monostatic). It is recommended that you connect the antenna(s) before powering on the reader.

Warning: You must use Impinj-approved antennas with Speedway/R. See “Appendix A: Information Specific to Regions of Operation” on page 19 for a detailed list of approved vendors. Using any other antenna may damage the reader or adversely affect performance. Speedway/R requires professional installation to correctly set the TX power for the RF cable and antenna selected.

To connect the antenna(s) to Speedway/R:

1. Position each reader antenna, keeping the following points in mind:
 - Position the antenna(s) to achieve the most effective and efficient tag reads. For details on the best layouts for various environments, see the *Impinj System Design Guide*.
 - Position the antenna(s) to maximize operator safety. Personnel who will be in the area for prolonged periods of time should be able to remain at a safe distance at all times. See “Appendix A: Information Specific to Regions of Operation” on page 19 for the specific requirements for your regularity region.
2. Mount the antenna(s) according to the instructions provided by the antenna manufacturer.
3. Attach the antenna cable(s) to the antenna port(s) on the reader. You can choose any port for any antenna.
4. Finger tighten the connection, making sure it is secure. A loose connection negatively impacts the performance of the antenna.

Caution: Impinj has designed its antenna ports to be self-terminating. Therefore, it is important that you do not terminate unused antenna ports. Leave them unconnected.

Step 3: Connect Speedway/R to the Network

You are now ready to connect the installed Speedway/R to your network. You have two options:

- If your network supports DHCP, you can connect the reader directly to your Ethernet network and, once the reader is powered, immediately communicate with it via Telnet (TCP/IP).
- If your network does not support DHCP you will need to connect a PC directly to the reader using a serial connection (RS-232), then use the reader’s Rshell command line interface to configure a static IP address for the reader. At that point you will be able to connect the reader to your Ethernet network.

Speedway Revolution Installation and Operations Guide

The details of completing each connection option are discussed below. Before proceeding, however, take note of the reader's factory default network settings:

Table 3: Default Network Settings

Setting	Description
hostname	Speedway-XX-XX-XX where XX-XX-XX is the last three bytes of the reader's MAC address (which is printed on the version label attached to the reader enclosure)
DHCP	Enabled. The reader also reports its hostname to the DHCP server.

To connect Speedway/R to the Ethernet network:

- Using a standard Ethernet cable, connect the RJ-45 connector on the reader to a LAN drop or network switch. A typical network configuration is illustrated below:

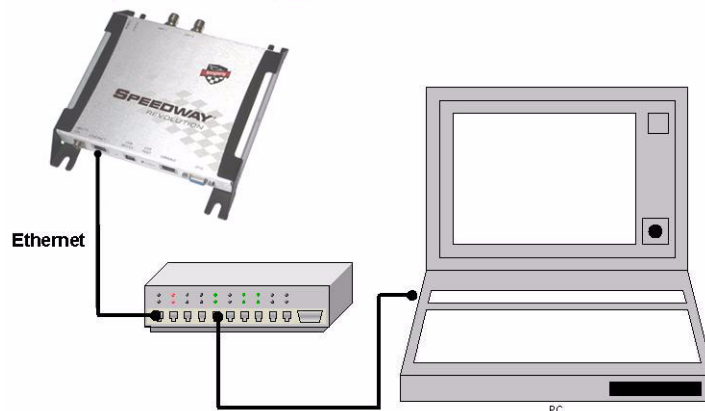

If your network switch is PoE-enabled, the reader will power on when you connect it to the network. See “Step 4: Power the Reader” on page 11 for information on what to expect.

Note: If you need to connect a PC directly to the Ethernet port, you can use a standard Ethernet cable. A crossover cable is not necessary.

To connect Speedway/R to your PC over a serial connection:

1. If necessary, download the latest version of Putty, which is a free and reliable SSH, Telnet, and serial client. Version 0.59 or higher contains support for serial connections.
2. Using a standard, grounded DB9 serial cable, connect your PC's valid/active COM port to the serial port on the reader, as illustrated below:

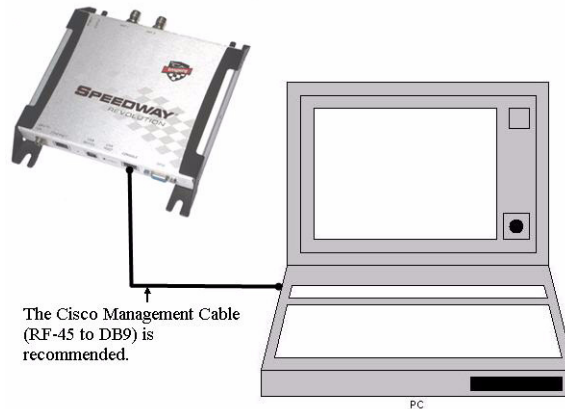

3. Power the reader and wait for the boot sequence to complete. (See “Step 4: Power the Reader” on page 11.)
4. On the PC, run the Putty application and select the **Serial** connection option. Verify that **Serial line to connect to** is set to **COM1** (if that is correct for your PC). Set **Speed** to **115200**. Set **Flow control** to **None**.

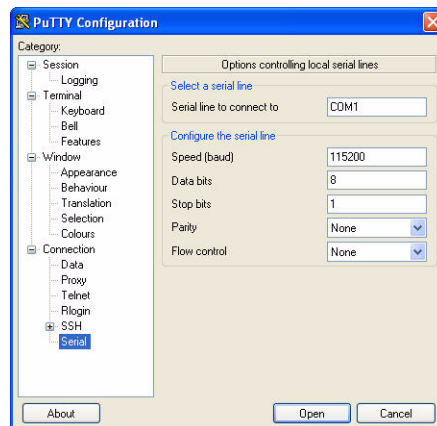

5. Click **Open**. The Rshell console window opens.
6. Log in with the following default credentials (unless they have been changed):
User Name: root
Password: impinj
7. When the Rshell command line prompt appears, you can begin configuring the network settings for the reader. See “Using Rshell to Configure Network Settings for Speedway/R” on page 13 for details.
8. When you have completed configuration of the appropriate network settings, connect the reader to your Ethernet network as described on page 9.

Note: If you decide to connect to DHCP after connecting serially, remember to use Rshell to change the IP address on the reader from static to dynamic. See “Using Rshell to Configure Network Settings for Speedway/R” on page 13 for details.

Step 4: Power the Reader

You have two choices for powering Speedway/R:

- Power over Ethernet (PoE)
- External power supply

If you are using PoE, your reader began receiving power when you connected it to the network in the previous step. Therefore, there is nothing more you need to do. If you are using an external power supply, connect the AC power plug into a suitable 100-240 VAC, 50-60 Hz power outlet.

In either case, when power is supplied to the reader, it begins its boot sequence. This sequence typically completes within 30 to 45 seconds. Until the boot sequence completes, the reader will not accept commands. The Power and Status LEDs on the reader alert you to what is happening. See the table labeled “Reader Operations and Associated Status LED Behavior” on page 6 for details.

Important: If a reader is receiving its power via PoE and it detects that an external power supply has been connected, the reader reboots and switches its power source from PoE to the external power supply. If, however, the reader is receiving power via an external power supply and it detects the connection to a PoE-enabled network switch, nothing changes. The reader continues to receive its power from the external supply. Because the external power supply is capable of higher power than PoE, it always takes precedence if both sources are connected.

Step 5: Use the MultiReader Application to Read Some Tags

To be completed later.

Chapter 2: Installing and Connecting Speedway/Revolution

Chapter 3: Configuring Speedway/ Revolution

This chapter will be completed later. It will include topics such as those listed below:

Configuration Overview

Using Rshell to Configure Network Settings for Speedway/R

Configuring the RFID Behavior of Speedway/R

Chapter 4: Monitoring Speedway/ Revolution

This chapter will be completed later. It will contain such topics as follows:

Using Rshell to Monitor Speedway/R

Viewing Speedway/R Logs

Chapter 5: Troubleshooting

This chapter will be completed later.

Appendix A: Information Specific to Regions of Operation

Speedway/R is designed to work in various regulatory regions. This appendix includes frequency ranges and antenna requirements specific to each supported region. Note that this first release of Speedway/R covers operation in North America only.

Important For each region, the reader is locked such that it can operate only in the specific frequencies for that region. The region-specific frequencies are listed in this appendix.

Operation in North America

Frequency Plan

The FCC specifies frequency hopping across the North American spectrum allocated to UHF RFID (902–928 MHz, with hopping occurring between 902.75–927.25 MHz in 500 KHz steps). This is further explained in the table below:

Table 4: Frequency Plan for North America

Transmit Channel Number	Center Frequency (MHz)
1	902.75
2	903.25
3	903.75
4	904.25
.	.
.	.
.	.
49	926.75
50	927.25

Antenna Requirements

Positioning

Position the antenna such that personnel who will be in the area for prolonged periods of time can remain at least 25 centimeters from the antenna’s surface. This is required by the FCC. For more details, see the following FCC bulletins:

- FCC OET Bulletin 65: *Evaluating Compliance with FCC Guidelines for Human Exposure to Radiofrequency Electromagnetic Fields*
- FCC OET Bulletin 56: *Questions and Answers about Biological Effects and Potential Hazards of Radiofrequency Electromagnetic Fields*

Installation

Because Speedway/R is capable of up to +32.5 dBm conducted power on the housing RF connector, professional installation is required.

Power

Speedway/R may only be operated with Impinj-approved antennas and can radiate no more than 36 dBm EIRP (Equivalent Isotropically Radiated Power) per FCC Part 15.247 regulations. The Speedway/R output power may be increased to provide the maximum allowable EIRP subject to a maximum conducted power allowance as well. The maximum conducted power at the antenna connector can be no more than 30 dBm. The maximum allowable output power of the reader can be set to satisfy both the conductor and radiated maximum criteria. The expression for the maximum reader power setting is:

$$\begin{aligned} &\text{Maximum power setting (in dBm)} \\ &= \text{The **Smaller** of} \\ &(36 - \text{Composite Antenna Gain (in dBm)}) \\ &\text{OR} \\ &(30 + \text{Cable Loss (in dBm)}), \end{aligned}$$

where the composite antenna gain comprises the maximum linear antenna gain in dBi minus any cable loss between the reader and antenna in dB. Approved antenna vendors, model numbers, and associated gain are listed in the next section.

Approved Antenna Vendors

- Cushcraft model number S9028PCL/R (left- or right-hand CP), with integrated 8 foot pigtail to RP-TNC male connector; 6 dBi composite gain
- Impinj model number IPJ-A0301-USA (Mini-Guardrail) with SMA female connector; -15 dBi gain
- Impinj model number IPJ-A0310-USA (Threshold-T Antenna) with 12 inch integrated pigtail to BNC male connector, 6 dBi composite gain.
- Impinj model number IPJ-A0400-USA, CSL CS-777-2 (Brickyard) with 7 foot integrated pigtail to RP-TNC male connector; 2 dBi composite gain
- Impinj model number IPJ-A0401-USA or IPJ-A0402-USA (both Guardwall) with 6 foot integrated pigtail to RP-TNC male connector; 6 dBi composite gain
- MA/COM MAAN-000246-FL1 integrated RFID floor-mounted stand (multiple configurations available, 2 or 4 antennas left-hand and right-hand CP) with 8 foot integrated pigtail to RP-TNC male connector; 6 dBi composite gain
- MA/COM MAAN-000246-WL1 integrated RFID wall-mounted stand (multiple configurations available, 2 antennas left-hand and right-hand CP) with 8 foot integrated pigtail to RP-TNC male connector; 6 dBi composite gain
- MTI MT-262006/TLH (left-hand CP) or MT-262006/TRH (right-hand CP) with RP-TNC female connector (antennas available in IP54 or IP67 ratings); 6 dBi gain
- MTI MT-262013/NLH (left-hand CP) or MT-262013/NRH (right-hand CP) with N-type female connector (antennas available in IP54 or IP67 ratings); 4.5 dBi gain
- MTI MT-262013/TLH (left-hand CP) or MT-262013/TRH (right-hand CP) with RP-TNC female connector (antennas available in IP54 or IP67 ratings); 4.5 dBi gain

Speedway Revolution Installation and Operations Guide

- Sensormatic Electronics Corp. model number IDANT20TNA25 with 25 foot Belden 7806A RG-58 coaxial cable (0.1 dB per foot loss) to RP-TNC male connector; 5.5 dBi composite gain
- Sensormatic Electronics Corp. model number IDANT10CNA25 with 25 foot Belden 7806A coaxial cable (0.1 dB per foot loss) to RP-TNC male connector; 3.5 dBi composite gain
- Sensormatic Electronics Corp. model number IDANT10CNA25 with 6 foot Belden 7806A coaxial cable (0.1 dB per foot loss) to RP-TNC male connector; 5.4 dBi composite gain

Warning The use of any antenna not listed above may damage the reader or adversely affect performance.

Appendix A: Information Specific to Regions of Operation

Appendix B: GPIO Details

The following graphic shows the detailed function of each pin of the GPIO DB-15 connector.

Figure 2: DB-15 GPIO Port

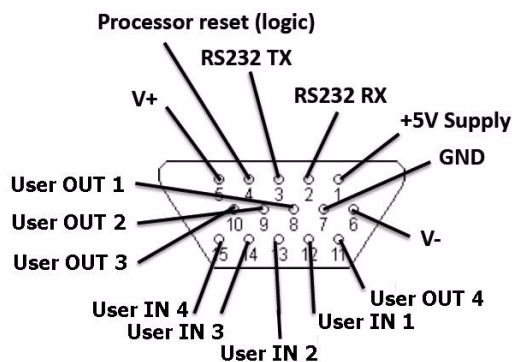

Note: Both the input and output pins are opto-isolated.

The following tables further explain the function of each pin.

Table 5: DB-15 Connector Pin-Out

Pin	I/O Name	I/O Function
1	+5V Supply	Reader supplied (not isolated) power source
2	RS-232 RX	For auxilliary serial port functions
3	RS-232 TX	For auxilliary serial port functions
4	Processor Reset	A hard reboot into the reader (Pulling this line low performs the same function as pressing the FDR button—see Table 2 on page 6 for details.)
5	V+	Power source for isolated outputs
6	V-	Return for isolated inputs and outputs
7	Ground	Reader (not isolated) return
8	User OUT 1	Isolated output 1 (active pull down to V-)
9	User OUT 2	Isolated output 2 (active pull down to V-)
10	User OUT 3	Isolated output 3 (active pull down to V-)
11	User OUT 4	Isolated output 4 (active pull down to V-)
12	User IN 1	Isolated input 1
13	User IN 2	Isolated input 2

Table 5: DB-15 Connector Pin-Out

Pin	I/O Name	I/O Function
14	User IN 3	Isolated input 3
15	User IN 4	Isolated input 4

Table 6: GPIO Interface Electrical Specification

Pin	Parameter	Description	Min	Max	Unit	Conditions
+5V Supply	I_O	Output current		200	mA	
User IN 1-4	V_{IH}	HIGH level input voltage	3	30	V	
User IN 1-4	V_{IL}	LOW level input voltage	0	2	V	
User IN 1-4	I_{LI}	Input current		5	mA	24V input
User IN 1-4	V_I	Input voltage range	0	30	V	No damage
User OUT 1-4	V_{OH}	Output high voltage		$V+^*$	V	10k pullup
User OUT 1-4	V_{OL}	Output low voltage		$V_{ol}+5$	V	200mA load
User OUT 1-4	V_I	Operating voltage range		40	V	

*User-supplied voltage