

InBody[®] USER'S MANUAL

Thank you for purchasing InBody H20 or H20[®].

H20[®] has Bluetooth function but H20 doesn't.

Please read this manual carefully and use it with proper operation.

Keep it handy for future reference.

*** This product is medical equipment.**

BIOSPACE

© 1996-2012 Biospace Co., Ltd. All rights reserved.

Notice

This user's manual cannot be copied, translated or transformed into different media without a prior written consent from Biospace Co., Ltd, according to the copyright laws. This user's manual and product pertinent to this manual may have misprints or technical flaws, which can be modified without prior notice to the readers. Biospace is not liable for any damage caused by a failure to meet the requirements in this user's manual.

Biospace Co., Ltd. [Head office]

518-10, Dogok 2-Dong, Gangnam-gu, Seoul 135-784, Korea

TEL : 82-2-501-3939

FAX : 82-2-578-2716

Homepage: <http://www.inbody.com>

E-mail: info@inbody.com

Acknowledgements

Biospace, InBody, Lookin' Body are the registered trademarks of Biospace Co., Ltd.

The names of the companies and products in this manual other than those of Biospace Co., Ltd. are the trademarks of the companies. Stating the products of other companies is strictly for the purpose of providing information, and not to guarantee or recommend the products. Biospace is not responsible for the performance or the use of these products.

Biospace reserves the right to modify the dimensions or exterior of InBody H20 to improve the quality of the products, without consent of the customer.

How to use this manual

This user's manual explains the functions of the InBody H20.

Follow the instructions below for effective use this manual.

1. Please read all the instructions in this manual thoroughly before operation.
2. Fully utilize the helpful materials, such as the diagrams and illustrations, to get a clear understanding of the product.
3. Before calling Biospace for assistance,
please refer to “ Chapter 11. One-minute check before calling for service ”.
4. If you have clinical issues while using the InBody H20, please contact us using the e-mail address as shown below.

E-mail : info@inbody.com TEL: 82-2-501-3939

5. Most importantly, please read the instructions and become familiar with the following notations:



The important information to warn you of situations which might cause major injury and/or damage to property if instructions are not carefully followed.



The important information to warn you of situations which might cause minor injury and/or damage to property if instructions are not carefully followed.



The important and helpful information for operation.

Safety Information

DANGER

Make sure not to use this equipment with medical electrical devices, such as a pacemaker.

NO USAR USARLO CON EQUIPO MEDICO ELECTRONICO ASI COMO CON MARCAPASOS.

CAUTION

Keep this equipment away from liquid.

MANTENER USARLO LEJOS DEL AGUA.



WARNING

1. Do not use this equipment in combination with the following electronic medical devices.
 - Medical devices, such as a pacemaker
 - Electronic life support systems, such as an artificial heart/lung
 - Portable electronic medical devices, such as an electrocardiograph.
2. Physically disabled persons or children should not attempt to take measurements alone, but instead should get help by having manager or guardian hold them from the side or the back not to slip or to measure incorrectly.
3. Do not dismantle the equipment or open the back cover. Internal parts are not for customer use. If the equipment is dismantled, the warranty is void, and service costs will be charged. If service is required, contact Biospace or the supplying agency.
4. When connecting peripherals (optional devices) to the InBody H20, turn on the power of the peripherals before turning on the InBody H20. When turning the power off, turn off the InBody H20 before turning off the peripherals. This process will minimize the harm to the equipment caused by electrical shock.

5. You may slip off the device if you step on it with wet feet.

6. The arm consists of a hand electrode. Do not force the arm in the wrong direction. The resulting damage may affect the functioning of the internal cable and circuit board.

7. Individuals with any kind of contagious disease or any kind of injury on the palm of their hand or sole of their foot should not come in contact with this product.

8. Never start weight reduction or exercise therapy without instruction from a physician or a specialist. Self-diagnosis may damage your health. Consult with your physician first.

9. This equipment is specifically designed to analyze body composition. Use the equipment only for its intended use as described in this manual.

10. Follow local governing ordinances and recycling plans regarding the disposal or recycling of device components.



1. Cross Contamination

Individuals with any kind of contagious disease or infection must not use or come in contact with the platform or this product. Please be sure to clean the platform with appropriate disinfectant after each use. Never pour any liquid directly on the platform, as it may leak and cause internal damage. Use a soft cloth and appropriate ethyl alcohol to wipe off the platform. Do not wipe the platform with strong chemicals.

2. While moving, installing or using this product, be sure to protect it against any physical shock or damage. Always use the packing material and the original shipping box when moving or transporting this product.

3. Always operate this product within prescribed ranges of temperature, humidity, and pressure. Operating in ranges outside of those specified may affect the operation of this product and may cause malfunctions.

4. Be careful not to spill or drop any residues of food or beverages on this product. It may cause serious damage to the electronic components.

5. Cleaning

Keep the platform and control panel clean by wiping them with disinfectant. Never pour any liquid directly on the platform, Use a soft cloth and appropriate ethyl alcohol to wipe off the platform. Do not wipe the platform with strong chemicals.

6. Wipe up gently the platform and control panel of the product with a soft cloth for disinfectant.

7. Install or locate equipment only in accordance with the provided installation instructions.

8. This equipment should be serviced only by qualified personnel. Contact Biospace for any Customer Service issues.

9. Please use your hands to operate buttons. Using feet may lead to malfunction of buttons.



1. This equipment may cause the above mentioned medical devices to malfunction.

This equipment may cause harmful interference to other devices in the vicinity, if not installed and used in accordance with the installation specifications. However, there is no guarantee that the interference will not occur for a particular installation.

2. Do not dismantle the product. Internal parts are not for customer use. If the unit is dismantled, the warranty is void, and service costs will be charged to you. If service is required, contact Biospace or the supplying agency.

3. This product should be serviced only by qualified service personnel. Contact Biospace for examination, repair or adjustment.

4. Do not move the equipment with the power on.

5. Do not jump or shock on the platform, these may cause an incorrect measurement or malfunction.

6. Keep this equipment away from liquid, other contaminates. These will cause a loss of function or a critical damage on the product. Do not put this product in direct sunlight, close to heaters.





Information





1. This product has been designed, manufactured, and inspected under the full quality assurance system of Biospace. Biospace fulfills European MDD(Medical Device Directive), and InBody H20 has acquired the CE conformity marking.
2. This equipment may cause the above mentioned medical devices to malfunction.
3. This equipment may cause harmful interference to other devices in the vicinity if not installed and used in accordance with the installation specifications. However, there is no guarantee that the interference will not occur for a particular installation.
4. The InBody H20 has been designed, manufactured, and inspected under the full quality assurance system of Biospace. Biospace fulfills the international standardization system, ISO 90001 and ISO 13485.
5. The InBody H20 fulfills the Standards of IEC60601-1(EN60601-1), Safety of Electric Medical Equipment. In addition, the InBody H20 complies not only with Level A for Noise Immunity, but also with Level A for Noise Emission by the Standard IEC60601-1-2(EN60601-1-2), Electromagnetic Compatibility Requirements.

Indicators & Safety Symbols

Symbols

	Attention, Consult accompanying documents	SN	Serial Number
	Type B applied part	EC REP	Authorised Representative In The European Community
	Date of manufacture	CE ₀₁₂₀ CE ₀₆₇₈	CE mark

Care Symbols on the Box

	This way up		Keep dry
	Stack up to 10 boxes		Fragile—handle with care
			No Hooks



Disposal of old Electrical & Electronic Equipment

(Application in the European Union and other European countries with separate collection system)

This symbol indicates that this product shall not be treated as household waste. Instead, it shall be handed over to the applicable collection point for the recycling of electrical and electronic equipment. By ensuring this product is disposed of correctly, you will help prevent potential negative consequences for the environment and human health, which could otherwise be caused by inappropriate waste handling of this product. For more detailed information about recycling this product, please refer to local governing ordinances and recycling plans.



Follow local government ordinances and recycling instructions regarding disposal or recycling of device components, including batteries.

Workplace Requirements

□ **Operation Environment**

Temperature range : 10 – 40 °C

Relative humidity : 30 – 75 %

Atmospheric pressure range : 70 – 106 kPa

□ **Storage Environment**

Temperature range : -20 – 70 °C

Relative humidity : 10 – 95 % (No condensation)

Atmospheric pressure range : 50 – 106 kPa

□ **Battery**

Rating : AA Type Battery(1.5V X 4ea)

Introduction

Body Composition consists of 4 major components: Water, Protein, Minerals and Fat. These four elements are the fundamental ingredients the body is comprised of, and it is important for them to be in balance. Body composition analysis is expected to quantify and measure these ingredients.

Until recently, diagnosing obesity has focused on appearance, without considering a balanced body composition. For more reasonable healthcare, accurate body composition analysis must be performed first, to achieve the balance of the four major body components.

Biospace has earned international recognition for technical expertise demonstrated through the InBody series. Based on the experience and technology over the last 10 years, Biospace has released the body composition analyzer, the InBody H20.

InBody is highly recognized for its world-best technological excellence by many customers in more than 40 different markets including the US, European countries, Japan, and more. The strong brand is well-known among medical professionals as well as academic communities, and now it is the time for you to meet InBody at your place. Enjoy healthy lifestyle with InBody!

Kichul Cha, CEO



Notice

Please read thoroughly and follow the instructions.

1. Please do not press



with other object on the platform.

2. Please use your hands to operate buttons. Using feet may lead to malfunction of buttons.

3. Please be sure to avoid keeping or using InBody in wet area, i.e. bathroom. It may cause malfunction of the device.

4. You may slip off the device if you step on it with wet feet.

5. Please wrap InBody and keep it level while storing for a long period.

6. Please remove the batteries from the device while not in use for a long time. It may cause corrosion when left in contact with the device.

(Please follow the instruction in reverse order of ' Chapter 2. Insert Battery ')

7. When you change the batteries, please use only the new batteries. The 4 batteries that are used should be the same model from the same company.

Contents

How to use this manual	I
Safety Information	II
Indicators & Safety Symbols	VII
Workplace Requirements	VIII
Introduction	IX
Notice	X
1. Product Package	1
2. Insert Battery	2
3. Connecting InBody H20® and PC	3
4. Weight Measurement Mode	4
5. InBody Test Mode	5
6. Maintenance	10
7. Understanding of Results	11
8. Error messages	14
9. One-minute check before calling for service	15
Appendix	17
* More about the InBody H20	
* Specifications	
* Customer Service Information	

1. Product Package

When opening the box, check to make sure all the following items are included.

Included Items

- ① InBody H20 unit
- ② Quick Installation Guide
- ③ Battery (AA 1.5 V 4 ea)
- ④ Bluetooth dongle



To prevent physical shock, use Biospace's packing material when shipping or transporting the equipment.

2. Insert Battery

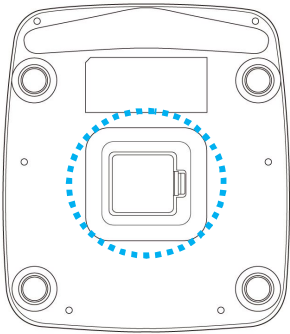

< Rear part >

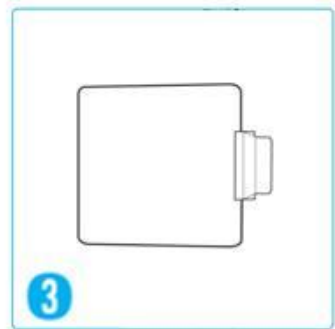
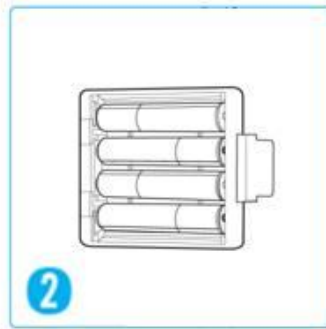

- (1) Open the battery cover at the bottom of the device.
- (2) Insert the batteries (AA 1.5 V 4 ea) in right direction.
- (3) Close the battery cover until it clicks.



NOTE

Battery is low when  is still on after you turn on InBody H20.



NOTE

Please replace the batteries when  is blinking after you turned on InBody H20.

3. Connecting InBodyH20[®] and PC

(1) Connect Bluetooth dongle(Bluetooth dongle from product package) to PC.

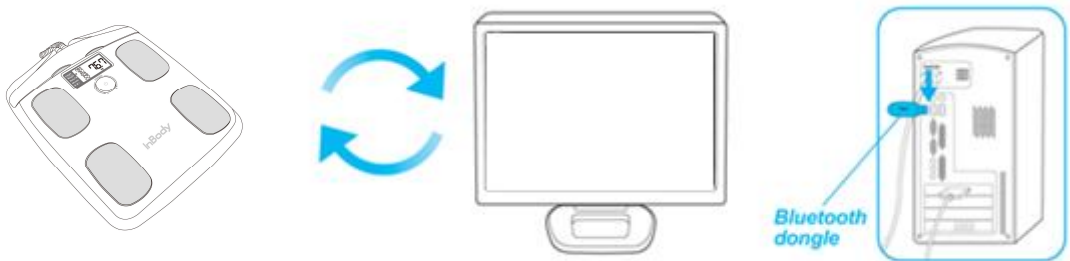

(2) Access <http://www.myinbody.com> and register.

(3) Click “InBody PC Program Install Guide” and install the program.

(4) Turn on H20[®]. When the bluetooth is being connected to InBodyH20[®], the logo will display on the LCD screen.



Please use the Bluetooth dongle provided by Biospace only.

4. Weight Measurement Mode

A. Body Composition Analyzing

- (1) Step on the foot board to measure your weight.
- (2) When the measurement is over there will be a beep and you will see your weight on the screen.
- (3) When the weight is not correct, press the foot plate to turn on H2O and wait for 5 seconds. Then you can re-measure your weight.

B. Power Off

- (1) Weight measurement is done, step down from the foot plate and the power will automatically be turned off.
- (2) If you step down the foot plate while measuring, the device will not be turned off for 20 seconds.

5. InBody Test Mode

A. Tips Before Body composition analyzing

- (1) Make yourself as light as possible. Wear light clothes for measurement.
- (2) Please go to the bathroom before measurement. Urine and feces affect your weight and consequently the body composition analysis.
- (3) Please conduct the measurement before meals or at least two hours after meals. Food in the stomach before digestion affects body weight, causing possible errors in the result.
- (4) Please avoid taking measurement right after bath, sauna, physical exercise. Body water is in instable condition after a bath, a sauna, or physical exercise, which could lead to incorrect measurement data.
- (5) It is recommended to have a test in the morning. Body composition is in the most stable condition before starting full activities of the day.
- (6) In case of repeated measurement to compare the results, please maintain surrounding conditions same (weight of clothes, time, food intake, etc.).
- (7) If you wear a pacemaker or other electronic medical devices inside your body, please do not use this body composition analyzer.

B. Body Composition Analyzing

- (1) Push the button in the center to turn on H20.
- (2) Rotate the button in the center to set your height. Wait for few seconds once it is set.
- (3) The height will appear on the LCD screen.

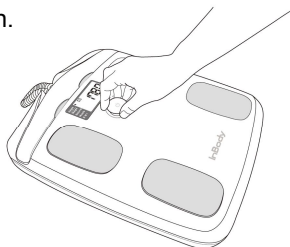
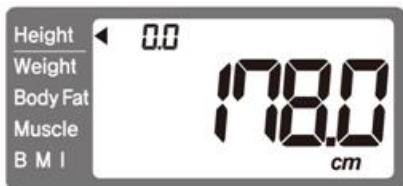

- (4) After entering the height hold the handle and step on the foot board to measure your weight.
- (5) When weight is set, the measurement position icon will blink while checking if the hand and feet electrodes are connected.



- (6) With measuring sound, InBody measurement will start. (The measurement will take 3~5 seconds)
- (7) When the test is over there will be a beep and you will see END on the screen. And Weight, Body fat Mass, Muscle Mass will be displayed on the LCD.

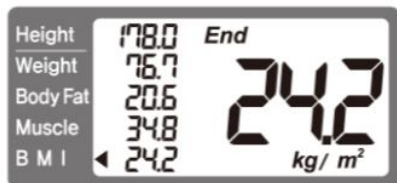

- (8) Measurement results will be shown twice and the END will appear on the LCD. After that you may release the handles and step down.
- (9) After stepping down, the result can be seen using the dial button.



Please use your hands to operate buttons. Using feet may lead to malfunction of buttons.



InBody H20[®] can be operated for the body composition analysis without connection to PC. For more results and data management, however, use of InBody H20[®] with PC connection is recommended..

C. How to Hold InBody Electrode

Take the hand grip and hold it with the palms and thumbs touching the hand electrodes. Step on the foot electrodes at the platform. Make sure your hands and feet on both sides are not touching each other. Please refer to next page for the right measurement posture.

The measurement begins automatically when your position is set.

(1) Hand Electrodes

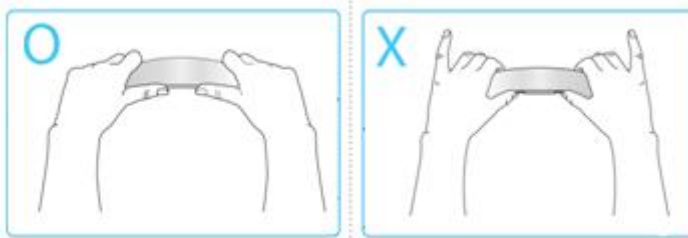

Fingers must not leave the surface of the electrodes. Right hand and left hand must not touch each other.

(2) Foot Electrodes



Step on the foot electrode with the heels first and then the entire soles of your feet.

Be careful not to stand with your heels on the pants hems.



NOTE

Make sure your bare hands and bare feet maintain contact with electrodes. Please be careful not to let the hems of your pants get stuck between your heels and the foot electrodes. In case your feet are relatively small, please step on the electrode with the heels touching them first.

D. Recommended measurement posture

- ❶ Please keep your eyes to the front.
- ❷ Grab the hand electrodes with bare hands and be careful not to let your hands touch each other.
- ❸ Thighs should not touch each other if possible.

*Tip: For those whose thighs contact each other, it is recommended to wear shorts, which come down below the thighs for accurate measurement.

- ❹ No moisture or too much callus tissues on the palms or soles of feet may lower the accuracy of the measurement.

*Tip : Wipe your hands and feet with wet tissues before the measurement.

- ❺ Take your socks or stockings off and measure with bare feet.

Step on the platform with your feet and the electrodes aligned on foot electrodes. Your feet must not contact each other.

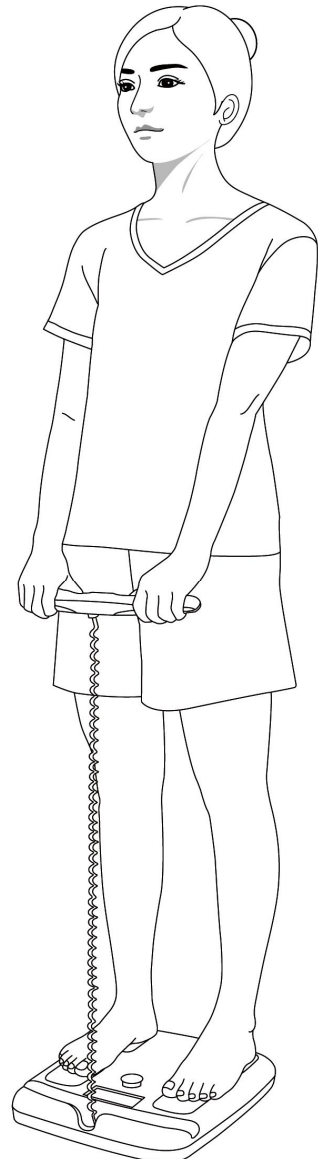

E. Power Off

(1) InBody test is done, step down from the foot plate and the power will automatically be turned off after 60 seconds. Turn the dial to see the measurement results again in 60 seconds.

(2) If you step down the foot plate while measuring, the device will not be turned off for 60 seconds. If you step on the foot plate within 60 seconds the measurement will restart.

6. Maintenance

(1) After usage, wipe electrodes with a wet tissue (also known as wet naps, surface wipes, anti-bacterial tissues, etc.) Wet tissues can be purchased at any local store.

(2) Handle the arms with care. Never apply excessive force near the hand electrode joint. The damage caused by misuse may affect the function of the internal cable and electric board.

(3) Do not place anything on the platform or apply any pressure onto it when the InBody H20 is not in use.

(4) Do not drop any food or liquid on the equipment. It may affect the electrical parts in the equipment or cause damage.

(5) Once a week, wipe the exterior sides of the InBody H20 with a dry towel. In particular, clean the LCD monitor, using gentle care not to scratch the surface.

(6) Follow local governing ordinances and recycling plans regarding the disposal or recycling of device components.

7. Understanding of Results

A. Result Screen

During measurement, the InBody H20 displays information of an examinee's body composition on the LCD. The results are shown while you are on the foot plate.

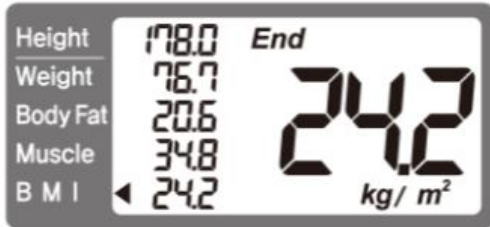

① Weight (kg)



Ideal weight is based on examinee's height. Using the classical BMI method, the InBody 370 identifies the standard BMI as 22kg/m² for males, 21.5kg/m² for western females and 21kg/m² for asian females.

Formula to get ideal weight

Male

$$\text{Ideal Weight} = \text{Height}^2(\text{m}^2) \times 22$$

Female

$$\text{Ideal Weight} = \text{Height}^2(\text{m}^2) \times 21 \quad (\text{asian})$$

$$\text{Ideal Weight} = \text{Height}^2(\text{m}^2) \times 21.5 \quad (\text{western})$$

The standard range of weight is 85~115% based on the standard range of BMI.

② Percentage of Body Fat (%)



Percentage of Body Fat indicates the percentage of body fat to body weight. The ideal percentage of body fat is 15% for men and 23% for women, while the standard range of Body Fat Mass for men is 10-20% of the weight and 18-28% of the weight for women. In the case of children under the age of 18, children's standard is used.

Ref. Samuel J. Fomon, et al. (1982): *Body Composition of reference children from birth to age 10 years. The American Journal of Clinical Nutrition* 35, 1169-1175.

③ Skeletal Muscle Mass (kg)



Distinctively, skeletal muscle mass, which generally indicates the lean body mass of each arm and leg, can be controlled by exercise and dietary habits. Compare the bar graphs' lengths of skeletal muscle mass with body fat mass. If the bar of skeletal muscle mass is relatively shorter and under the standard value, lean body mass lacks in the body, while the opposite case is proper. 100% signifies ideal lean body mass when examinee's weight is normal. The standard range is 90~110% of standard skeletal muscle mass based on standard weight.

④ BMI (Body Mass Index, kg/m²)

BMI is determined by using only weight and height and diagnoses superficial obesity. The standard values are 22kg/m² for male and 21.5kg/m² for western female and 21kg/m² for asian female.

Formula) BMI = weight (kg) ÷ height² (m²)

Determination 1) WHO Standard

BMI(kg/m ²)	Classification		Diagnosis
<18.5	Underweight	Under	Infectious disease, malnutrition related disease
18.5~24.9	Normal	Standard	Least risk at most disease
25.0~29.9	Overweight	Over	May cause health problem
30.0~34.9	Obese1		Increase of the risk of cardiac disease, high blood pressure, diabetes, etc
35.0~39.9	Obese2		
>40	Severely Obese		

Ref. WHO and the National Heart, Lung, and Blood Institute: clinical guidelines on the identification, evaluation, and treatment of overweight and obesity in adults, the evidence report. June 1998, xiv

Determination 2) Asian-Pacific Standard

BMI(kg/m ²)	Classification	Diagnosis
<18.5	Underweight	Low (high risk of other clinical disease)
18.5~22.9	Normal	Average
>23	Overweight	
23~24.9	Risky Overweight	Increased
25.0~29.9	Obese step1	Moderate
>30	Obese step2	Severe

Ref. Korean Society for the Study of Obesity, chapter 2. Redefining and Evaluation, The Asian-Pacific perspective : Redefining Obesity and its Treatment., 1st edition, Korean Society for the Study of Obesity, 2001, p10.

8. Error Messages

InBody H20 helps users respond to possible malfunctions that may occur by displaying error messages described below. This is the list of typical error messages and adequate responses.

A. Error 1.



Cause 1 Bad body posture due to poor contacts at hand or foot electrodes.

Actuion1 See "Chapter 6 - C. How to Hold InBody Electrode" and correct the body posture.

B. Error 2.



Cause 1 Fundamental problem of the device suspected.

Actuion1 Please contact Customer Support . (info@inbody.com)

9. One-Minute Check Before Calling for Service

This section lays out the order of steps you have to take in case of malfunction, with the assumption that you have some basic knowledge about how to operate the equipment. If you still have the problem after taking the following steps, contact the local distributor or Biospace.

A. I cannot turn on the device even though I press InBody or Weight button.

Cause 1 The batteries might have been fully discharged.

Action 1 Replace the batteries.

Cause 2 User might have pressed  too shortly.

Action 2 Press and hold the button until the screen lights up.

B. Measurement data looks strange.

(Percent body fat, muscle mass, or other parameters are too high or too low.)

Cause 1 Poor contact between the body and the electrodes or incorrect body posture.

Action 1 Please maintain correct body posture throughout the test.

Cause 2 Measured weight looks strange.

Action 2 Please check if the hand grip is placed at right position.

or Please check Weight Offset in the configuration.

Cause 3 Personal information of others – ID, height, etc. – might have changed.

Action 3 Please check ID, age, height, gender, and other personal information. If height information is wrong, please correct it.

C. Measurement data is not transferred.

(When the Bluetooth is connected, the data will be automatically transferred after the measurement.)

Cause 1 Poor connection of the Bluetooth dongle. Its connection can be checked by the Bluetooth icon.

Action 1 Please check if there is a Bluetooth icon on the LCD and reconnect the Bluetooth dongle.

Action 2 Please find the Bluetooth icon from Control Panel and double click, then below screen will appear. Please set as below picture and click “OK” button to save the set value.

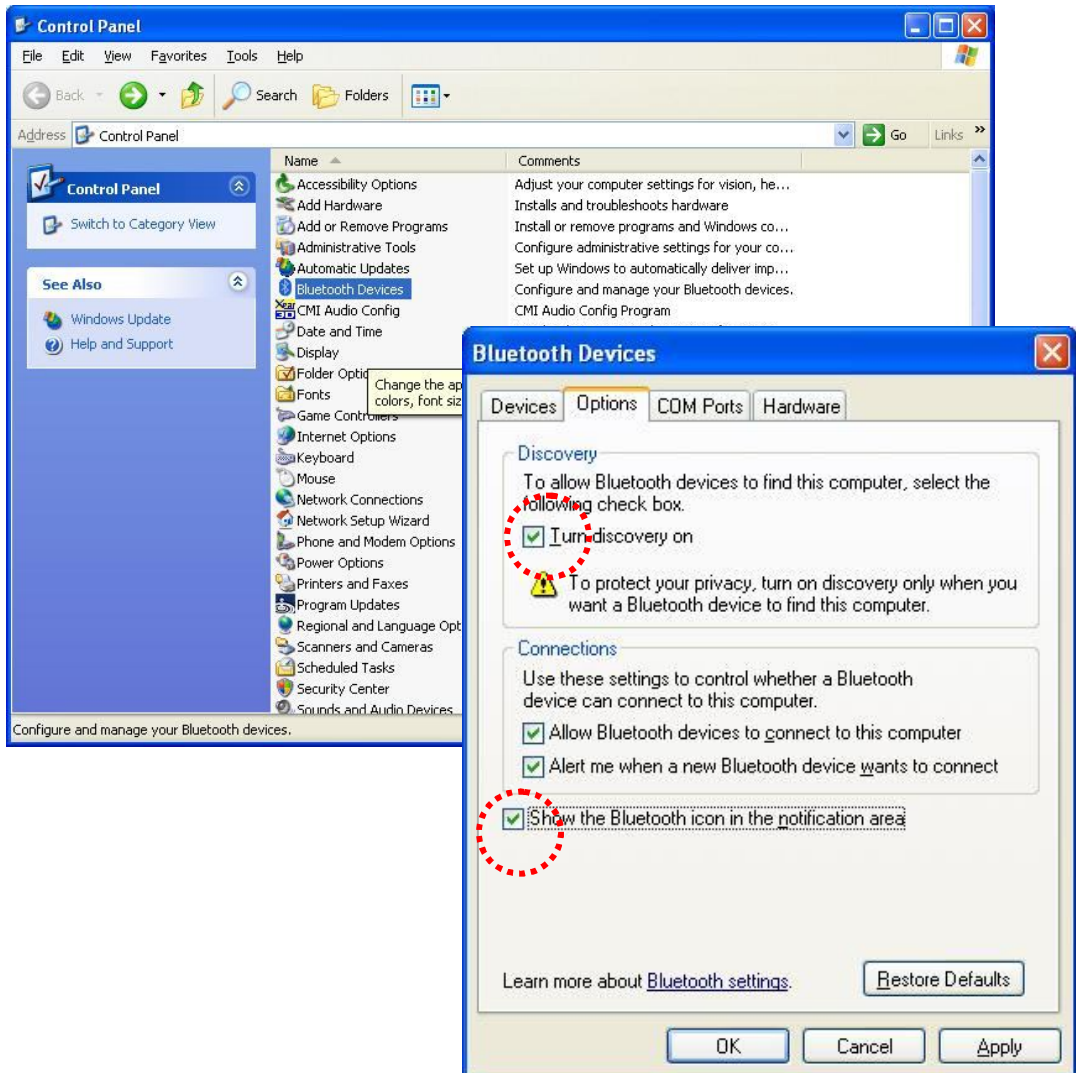

Appendix

More about the InBody H20

A. How does BIA work?

The Bioelectrical Impedance Analysis (BIA) method is based on the fact that the human body consists of conductors and non-conductors. Generally, 50~70% of the human body consists of water which functions as a conductor, whereas body fat functions as a non-conductor.

The classic BIA method measures the impedance of the whole body on the assumption that the human body can be considered a cylinder for the application of this model. If A is the cross sectional area, and L is the length, the impedance of the cylinder can be expressed as follows.

$$Z = \rho \frac{L}{A} (\rho = \text{resistivity})$$

If both sides are multiplied by L, We get the new expression as follows.

$$V = \rho \frac{L^2}{Z} (V(\text{Volume}) = A(\text{Area}) \times L (\text{Length}))$$

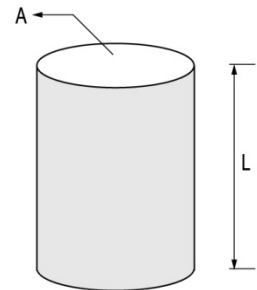

According to this expression, if we know the L and the impedance value, we get the volume. That is to say, if we know the height of the human body (acting as a conductor), and know the impedance value, we can get the volume of body water. Here, the volume represents examinee's height. Therefore, the two directly used variables in body composition analysis are impedance and height.

The principle of the InBody H20's body composition analysis is explained by the following; the volume of body water, an electrolyte, is calculated first with a measured impedance value. Then, we can get the value of fat free mass using the volume of body water. Body fat mass is determined by deducting the lean body mass from the measured weight.

Height should be entered by the user. Weight can be directly measured on the InBody H20.

B. Core Technology

The following are key features that make the InBody H20 extremely convenient, timely, and accurate.

(1) Tetrapolar 8-Point Tactile Electrode

It was a complex and inconvenient procedure to attach and detach the electrodes to a specific spot every time. Trained technicians were needed for each measurement. The InBody H20 uses tactile electrodes to avoid the possibility of errors and inaccuracies. The 8-point Tactile Electrode method enables the InBody H20 to efficiently produce accurate data every time.

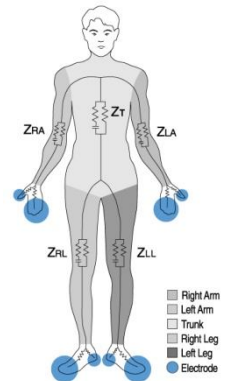

(2) Segmental Analysis

There are some claims to be able to estimate the body composition separately; there is no technology which can really measure it separately other than Biospace. Segmental measurement is the technology that assumes the body as five cylinders of four limbs and trunk and measures the impedance of these parts separately. Segmental body composition analysis provides segmental measurement of body water, muscle mass, and fat free mass. Furthermore, the analysis is highly accurate because the measured value of a certain part does not affect the measurements of other segments. It is because body composition analyzers lack accuracy in measuring body fat and cannot figure out the patient's exact shape that they must rely on empirical references to correct inaccurate measured values. But, the InBody with the technology of segmental analysis can exactly figure out difference by gender, aging, disease and ethnic without any empirical estimation. Based on the fact that fat free mass (FFM) consists of about 73.3% of body fluid, it can be concluded that the distribution of body fluid reflects the distribution of FFM. Because the InBody can analyze the segmental body fluid distribution (each arm, trunk, and each leg separately), it can as a result examine a patients segmental development.

C. Classifications

Type of protection against electric shock: Internally Powered Equipment

Degree of protection against electric shock: Type B Applied Parts

Degree of protection against the ingress of water: Ordinary equipment: IPX0

Equipment not suitable for use in the presence of a flammable anesthetic mixture with air or with oxygen or nitrous oxide.

Mode of operation: Continuous operation



Any changes or modifications in construction of this device which are not expressly approved by the party responsible for compliance could void the user's authority to operate the equipment.

Contains transmitter FCC ID : QQQWT11



This equipment has been tested and found to comply with the limits for a Class A digital device, pursuant to part 15 of the FCC Rules. These limits are designed to provide reasonable protection against harmful interference when the equipment is operated in a commercial environment. This equipment generates, uses, and can radiate radio frequency energy and, if not installed and used in accordance with the instruction manual, may cause harmful interference to radio communications. Operation of this equipment in a residential area is likely to cause harmful interference in which case the user will be required to correct the interference at his own expense.

D. Specifications

Items & Standard	BODY COMPOSITION ANALYZER of Direct Segmental Multi-frequency Bioelectrical Impedance Method	
Bioelectrical Impedance(BIA) Measurement Items	Bioelectrical Impedance(Z)	10 Impedance Measurements by Using 2 Different Frequencies (20 kHz and 100 kHz) at Each of 5 Segments (Right Arm, Left Arm, Trunk, Right Leg and Left Leg)
Electrode Method	Tetrapolar 8-Point Tactile Electrodes	
Measurement Method	Direct Segmental Multi-frequency Bioelectrical Impedance Analysis Method; DSM-BIA Method	
Body Composition Calculation Method	No Empirical Estimation	
Outputs	Weight, Skeletal Muscle Mass, Percent Body Fat, BMI	
Applied Rating Current	450 μ A	
Power	DC 6V (1.5V X 4ea) AA Type Battery	
Dimensions	310.3(W) \times 356.4(L) \times 58.3(H) : mm	
Machine Weight	2.7kg (6lb.)	
Measurement Duration	5 seconds	
Color	Soft White	
Operation Environment	10 ~ 40°C, 30 ~ 75%RH, 70 ~ 106kPa	
Storage Environment	-20 ~ 70°C, 10 ~ 95%RH, 50 ~ 106kPa (No condensation)	
Weight Range	10 ~ 200kg (22 ~ 440.9 lb.)	
Height Range	50 ~ 300cm (19.68 ~ 118.1 in.)	

* Specifications may change without prior notice.

E. Customer Service Information

Corporate agents' addresses are listed below. Contact us for assistance or more information.

Biospace Co., Ltd.

518-10, Dogok 2-Dong, Gangnam-gu, Seoul 135-784, Korea

TEL : 82-2-501-3939

FAX : 82-2-578-2716

Homepage://www.inbody.com

E-mail : info@inbody.com

Biospace Japan Inc. [JAPAN]

Second Floor Ayabe Bldg., 2-17-3 Sotokanda, Chiyoda-ku, Tokyo JAPAN

TEL : 81-03-5298-7667

FAX : 81-03-5298-7668,7669

Homepage : <http://www.biospace.co.jp>

E-mail : biospace@biospace.co.jp

Biospace Inc. [U.S.A]

8820 Wilshire Blvd. Suite 310 Beverly Hills, CA 90211 U.S.A

TEL : 1-310-358-0360

FAX : 1-310-358-0370

Homepage : <http://www.biospaceamerica.com>

E-mail : USA@biospaceamerica.com

EU Representative. [Europe]

DongBang Acuprime.

Gater House, Gater Lane, Palace Gate, Exeter, EX1 1JL, UK

TEL : 44-1392- 273908

FAX : 44-1392- 273909

E-mail : info@acuprime.com

Biospace China. [CHINA]

Block A, 26/F, Hai Xing plaza, No. 1 South Ruijin Road, Shanghai 200023, CHINA

TEL : 86-21-64439738, 9739, 9705

FAX : 86-21-6443906

Homepage : <http://www.biospacechina.com>

E-mail : admin@biospacechina.com

FCC Information

This device complies with Part 15 of the FCC Rules. Operation is subject to the following two conditions:

- (1) This Device may not cause harmful interface, and
- (2) This device must accept any interference received, including interference that may cause undesired operation.

Note: This equipment has been tested and found to comply with the limits for CLASS B digital device, pursuant to Part 15 of FCC Rules. These limits are designed to provide reasonable protection against harmful interference when the equipment is operated in a commercial environment. This equipment generates, uses and can radiate radio frequency energy and, if not installed and used in accordance with the instructions, may cause harmful interference to radio communications. However, there is no guarantee that interference will not occur in a particular installation. If this equipment does cause harmful interference to radio or television reception, which can be determined by turning the equipment off and on, the user is encouraged to try correct the interference by one or more of the following measures:

- 1.1. Reorient or relocate the receiving antenna.
- 1.2. Increase the separation between the equipment and receiver.
- 1.3. Connect the equipment into an outlet on a circuit different from that to which receiver is connected.
- 1.4. Consult the dealer or experienced radio/TV technician for help.

WARNING

Changes or modifications not expressly approved by the manufacturer could void the user's authority to operate the equipment.

“CAUTION : Exposure to Radio Frequency Radiation.

Antenna shall be mounted in such a manner to minimize the potential for human contact during normal operation. The antenna should not be contacted during operation to avoid the possibility of exceeding the FCC radio frequency exposure limit. The minimum separation distance of 20cm from the antenna to the body of user required.”