

# Cooker with gas oven and gas grill

Instructions for installation and use

**K6G21/G**

**K6G210/G**

 **INDESIT**



**GB** **Cooker with gas oven and gas grill**  
Instructions for installation and use

# Important safety warnings

To maintain the **EFFICIENCY** and **SAFETY** of this appliance, we recommend:

- call only the **Service Centers** authorized by the manufacturer
- always use **original Spare Parts**

- 1** These instructions are only for those countries whose symbols appear in the booklet and on the matriculation plate of the appliance.
- 2** This appliance is intended for non-professional use within the home.
- 3** Before using the appliance, read the instructions in this owner's manual carefully since you should find all the instruction you require to ensure safe installation, use and maintenance. Always keep this owner's manual close to hand since you may need to refer to it in the future.
- 4** When you have removed the packing, check that the appliance is not damaged. If you have any doubts, do not use the appliance, contact your nearest Ariston Service Centre. Never leave the packing components (plastic bags, foamed polystyrene, nails, etc.) within the reach of children since they are a source of potential danger.
- 5** The appliance must be installed only by a qualified person in compliance with the instructions provided. The manufacturer declines all responsibility for improper installation which may harm persons and animals and damage property.
- 6** The electrical safety of this appliance can only be guaranteed if the cooker is correctly and efficiently earthed, in compliance with current regulations on electrical safety. Always ensure that the earthing is efficient; if you have any doubts call in a qualified electrician to check the system. The manufacturer declines all responsibility for damage resulting from a system which has not been earthed.
- 7** Before plugging the appliance into the mains, check that the specifications indicated on the data plate correspond to those of the electrical and gas mains system of your home.
- 8** Check that the electrical capacity of the system and sockets will support the maximum power of the hob, as indicated on the data plate. If you have any doubts, call in a qualified technician.
- 9** An omnipolar switch with a contact opening of at least 3 mm or more, is required for the installation.
- 10** If the socket and hob plug are not compatible, have the socket replaced with a suitable model by a qualified technician who should also check that the cross-section of the socket cable is suited to the power absorbed by the appliance. The use of adaptors, multiple sockets and/or extensions, is not recommended. If their use can not be avoided, remember to use only single or multiple adapters and extensions which comply with current safety regulations. In these cases, never exceed the maximum current capacity indicated on the single adaptor or extension and the maximum power indicated on the multiple adapter.
- 11** Do not leave the appliance plugged in if it is not in use. Switch off the main switch and gas supply when you are not using the cooker.
- 12** The openings and slots used for ventilation and dispersion of heat on the rear and below the control panel must never be covered.
- 13** The user must not replace the supply cable of this appliance. Always call an after-sales servicing centre authorised by the manufacturer in the case of cable damage or replacement.
- 14** This appliance must be used for the purpose for which it was expressly designed. Any other use (e.g. heating rooms) is considered to be improper and consequently dangerous. The manufacturer declines all responsibility for damage resulting from improper and irresponsible use.
- 15** A number of fundamental rules must be followed when using electrical appliances. The following are of particular importance:
  - do not touch the appliance when your hands or feet are wet
  - do not use the appliance barefooted
  - never allow the Mains Cable to be stretched, pulled or damaged if the Cooker is moved for cleaning etc. Do not use the cooker if the Mains Cable is damaged, consult a qualified electrician.
  - do not allow the cooker to be used unsupervised by children or persons unfamiliar with it.
- 16** Always switch off the electrical supply to the cooker and allow it to cool down before carrying out any cleaning operations etc.
- 17** If you are no longer using an appliance of this type, remember to make it unserviceable by unplugging the appliance from the mains and cutting the supply cable. Also make all potentially dangerous parts of the appliance, safe, above all for children who could play with the appliance.
- 18** To avoid accidental spillage do not use cookware with uneven or deformed bottoms on the burners or on the electric plates.
- 19** Special care should be taken when using chip pans etc. in order to avoid splashing or spillage of hot oil. They should not be used unattended since overheated oil may boil over and could also ignite.
- 20** Parts of this appliance, cooking surfaces, retain heat for considerable periods after switching off. Care should, therefore, be taken when touching these areas before they have completely cooled down.
- 21** Never use flammable liquids such as alcohol or gasoline, etc. near the appliance when it is in use.
- 22** When using small electric appliances near the hob, keep the supply cord away from the hot parts.
- 23** Make sure the knobs are in the "●"/"○" position when the appliance is not in use.
- 24** **When the appliance is in use, the heating elements and some parts of the oven door become extremely hot. Make sure you don't touch them and keep children well away.**
- 25** **Gas units need a regular air replacement for a correct functioning. Make sure that the requirements requested in the "Positioning" paragraph are all observed in the owner's manual.**
- 26** If the cooker is placed on a pedestal, take the necessary precautions to prevent the same from sliding off the pedestal itself.
- 27** **Warning:** never place hot containers or items and flammable materials inside the dishwarmer drawer.
- 28** **This owner's manual is for a class 1 appliance (installed independently) or class 2, subclass 1 appliances (installed between two cabinets).**

# Installation

The following instructions should be read by a qualified technician to ensure that the appliance is installed, regulated and technically serviced correctly in compliance with current regulations.

**Important: remember to unplug the appliance from the mains before regulating the appliance or carrying out any maintenance work.**

## Positioning

**Important:** The hob should never be installed in proximity of a door access. People opening and closing the door could come into contact with pots or pans cooking on the hob.

**Important:** this unit may be installed and used only in permanently ventilated rooms according to the British Standards Codes Of Practice: B.S. 6172/B.S. 5440, Par. 2 and B.S. 6891 Current Editions. The following requirements must be observed:

- The cooker should not be installed in a bed sitting room with a volume of less than  $20\text{m}^3$ . If it is installed in a room of volume less than  $5\text{m}^3$  an air vent of effective area of  $110\text{cm}^2$  is required, if it is installed in a room of volume between  $5\text{m}^3$  and  $10\text{m}^3$  a supplementary airvent area of  $50\text{cm}^2$  is required, if the volume exceeds  $11\text{m}^3$  no airvent is required. However, if the room has a door or a window which opens directly to the outside no air vent is required even when the volume is between  $5\text{m}^3$  and  $11\text{m}^3$ .
- During prolonged use of the appliance you may consider it necessary to open a window to the outside to improve ventilation.
- If there are other fuel burning appliances in the same room, B.S.5440 Part 2 Current Edition, should, be consulted to determine the requisite air vent requirements.

## Levelling Your Appliance (only on certain models)

4 support feet which are adjusted using screws are located in the lower part of the cooker. These level off the oven when necessary. It is essential that the cooker be standing level.

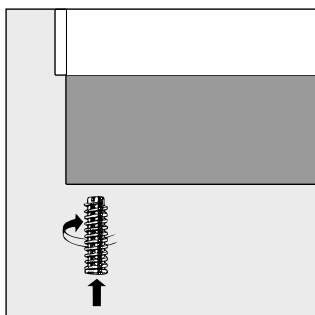

## Mounting the legs (only on certain models)

Press-fit legs are supplied which fit under the base of your cooker.

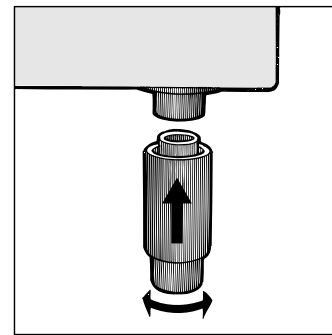

## Installation of the cooker

The cooker is prepared with protection degree against excessive heating of type X, the appliance can therefore be installed next to cabinets, provided the height does not exceed that of the hob. If the cooker is placed touching walls or sides of neighbouring cabinets, these must be capable of withstanding a temperature rise of  $50^\circ\text{C}$  above room temperature. For a correct installation of the cooker the following precautions must be followed:

- The cooker may be located in a kitchen, a kitchen/diner or bed sitting room, but not in a bathroom or shower room.
- The furniture units next to the cooker, that is higher than the working boards, must be placed at least  $600\text{mm}$  from the edge of the board. Curtains must not be fitted immediately behind the cooker or within  $600\text{mm}$  of the sides of the cooker.
- The hoods must be installed according to the requirements in the hood handbook.
- Wall cabinets may be fitted in line with the sides of the base units, providing that the lower edge of the wall cabinet is a minimum of  $420\text{mm}$  above the worktop. The minimum distance combustible material kitchen units can be fitted directly above the worktop is  $700\text{mm}$  (Fig. A).
- The wall in contact with the back of the cooker must be of flameproof material.
- The cooker is fitted with a safety chain that must be attached to a hook, secured to the wall behind the appliance.

**Note:** some models can have their gas connection inverted. It is important to make sure the safety chain is always situated on the side which corresponds to the hose holder (Fig. B).

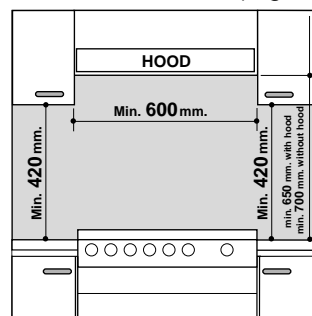

Fig. A

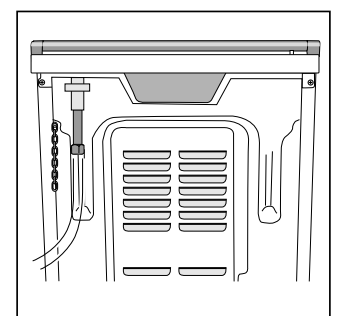
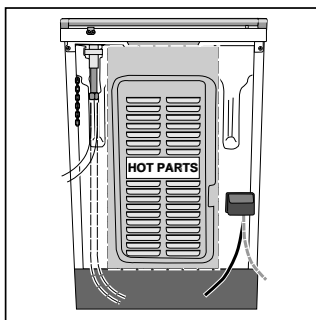

Fig. B

## Gas connection

The cooker should be connected to the gas-supply by a corgi registered installer. During installation of this product it is essential to fit an approved gas tap to isolate the supply from the appliance for the convenience of any subsequent

removal or servicing. Connection of the appliance to the gas mains or liquid gas must be carried out according to the prescribed regulation in force, and only after it is ascertained that it is adaptable to the type of gas to be used. If not, follow the instructions indicated in the paragraph headed "Adaptation to different gas types". On some models the gas supply can be connected on the left or on the right, as necessary; to change the connection, reverse the position of the hose holder with that of the cap and replace the gasket (supplied with the appliance). In the case of connection to liquid gas, by tank, use pressure regulators that conform to the regulation in force. The gas supply must be connected to the left of the appliance. Be sure that the hose does not pass through the rear of the cooker touching hot parts.



**Important:** make sure the supply pressure conforms with the values shown in the table entitled "Characteristics of the burners and nozzles". **When the cooker is installed between cabinets (recessed), the gas connection must be effected by an approved flexible hose with bayonet fitting (BS 669 Current Edition). The gas inlet for the cookers is a threaded G 1/2 gas female fitting.**

#### Connecting the gas supply

To make the connection, a flexible hose should be used corresponding to the current gas regulations which are:

- the hose must never be at any point in its length in contact with the "hot" parts of the cooker;
- the hose must never be longer than 1,5 metre;
- the hose must not be subject to any tension or torsional stress and it must not have any excessively narrow curves or bottlenecks;
- the hose must be easy to inspect along its entire length to check its condition;
- the hose must always be in good condition, never attempt to repair.

**Important:** the installation must comply with gas safety (installation and use) regulations 1984. In all cases for the above, by law, a qualified, corgi approved engineer must be called for installation.

#### Electrical connection

Power supply voltage and frequency: 220-240V a.c. 50/60 Hz.

**Note:** the supply cable must be positioned so that it never reaches at any point a temperature 50°C higher than the room temperature. The cable must be routed away from the rear vents. Should you require it, you may use a longer cable, however, you must ensure that the cable supplied with the appliance is replaced by one of the same specifications in accordance with current standards and legislation.

Your appliance is supplied with a 13 amp fused plug that can be plugged into a 13 amp socket for immediate use. Before using the appliance please read the instructions below.

**WARNING - THIS APPLIANCE MUST BE EARTHED. THE FOLLOWING OPERATIONS SHOULD BE CARRIED OUT BY A QUALIFIED ELECTRICIAN.**

#### Replacing the fuse:

When replacing a faulty fuse, a 13 amp ASTA approved fuse to BS 1362 should always be used, and the fuse cover re-fitted. If the fuse cover is lost, the plug must not be used until a replacement is obtained.

#### Replacement fuse covers:

If a replacement fuse cover is fitted, it must be of the correct colour as indicated by the coloured marking or the colour that is embossed in words on the base of the plug. Replacements can be obtained directly from your nearest Service Depot.

#### Removing the plug:

If your appliance has a non-rewireable moulded plug and you should wish to remove it to add a cable extension or to re-route the mains cable through partitions, units etc., please ensure that either:

- the plug is replaced by a fused 13 amp re-wireable plug bearing the BSI mark of approval.
- or:
- the mains cable is wired directly into a 13 amp cable outlet, controlled by a switch, (in compliance with BS 5733) which is accessible without moving the appliance.

**Please note:** for appliances with a rating greater than 13 amp (eg: electric hob, double ovens and freestanding electric cookers etc.) the mains cable must be wired into a cooker output point with a rating of 45 amp. In this case the cable is not supplied.

#### Disposing of the plug:

Ensure that before disposing of the plug itself, you make the pins unusable so that it cannot be accidentally inserted into a socket. Instructions for connecting cable to an alternative plug:

**Important:** the wires in the mains lead are coloured in accordance with the following code:

Green & Yellow	- Earth
Blue	- Neutral
Brown	- Live

If the colours of the wires in the mains lead do not correspond with the coloured markings identifying the terminals in your plug, proceed as follows:

Connect Green & Yellow wire to terminal marked "E" or  or coloured Green or Green & Yellow.

Connect Brown wire to terminal marked "L" or coloured Red.

Connect Blue wire to terminal marked "N" or coloured Black.

If a 13 amp plug (BS 1363) is used it must be fitted with a 13 amp fuse. A 15 amp plug must be protected by a 15 amp fuse, either in the plug or adaptor or at the distribution board. If you are in any doubt about the electrical supply to your machine, consult a qualified electrician before use.

#### How to connect an alternative plug:

The wires in this mains lead are coloured in accordance with the following code:

**BLUE**  
**BROWN**  
**GREEN AND YELLOW**

**“NEUTRAL” (“N”)**  
**“LIVE” (“L”)**  
**“EARTH” (“E”)**

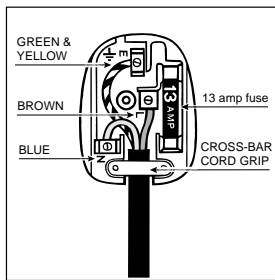

### Disposing of the appliance

When disposing of the appliance please remove the plug by cutting the mains cable as close as possible to the plug body and dispose of it as described above.

### Adapting the cooker to different types of gas

In order to adapt the cooker to a different type of gas with respect to the gas for which it was produced (indicated on the label attached to the lid), follow these steps:

#### a) Replacing the burner nozzles on the hob:

- remove the grids and slide the burners from their housings;
- unscrew the nozzles using a 7 mm socket spanner, and replace them with nozzles for the new type of gas (see table 1 “Burner and nozzle characteristics”).
- replace all the components by repeating the steps in reverse order.

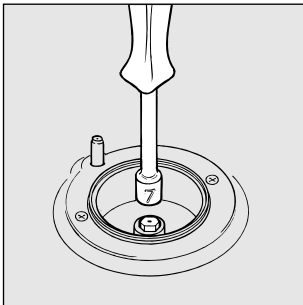

#### b) Minimum regulation of the hob burners:

- turn the tap to minimum;
  - remove the knob and adjust the regulation screw, which is positioned in or next to the tap pin, until the flame is small but steady.
- N.B.:** in the case of liquid gas, the regulation screw must be screwed in to the bottom.
- check that the flame does not turn off when you turn the tap quickly from high to low.

#### c) Regulating the primary air of the burners:

The primary air of the burners requires no regulation.

### Adapting to different types of gas

In order to adapt the oven to a different type of gas with respect to the gas for which it was manufactured (indicated on the label), follow these simple steps:

#### a) Replacing the oven burner nozzle

- open the oven door fully
- pull out the sliding oven bottom
- unscrew the burner fastening screws

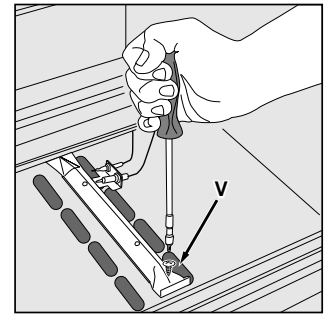
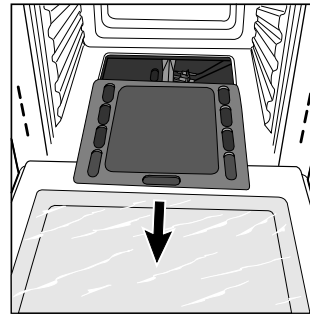

- remove screw “V” and then the oven burner;
- Unscrew the oven burner nozzle using the special socket spanner for the nozzles, or a 7 mm socket spanner, and replace it with a nozzle suited to the new type of gas (see Table 1).

**Take particular care handling the spark plug wires and the thermocouple pipes.**

- Replace all the parts, following the steps described above in the reverse order.

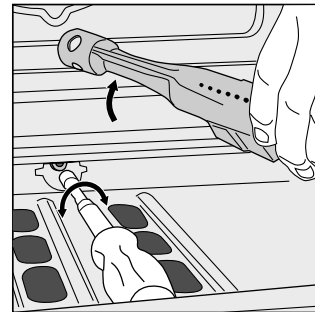

#### b) Minimum regulation of the gas oven burner with thermostat:

- light the burner as described in the paragraph “the oven knob” of the instruction booklet.
- turn the knob to **Max** for about 10 minutes and then turn the knob to the **Min** setting;
- remove the knob;
- regulate the screw positioned outside the thermostat pin until the flame is small but steady.

**N.B.:** in the case of liquid gas, the regulation screw must be screwed in to the bottom.

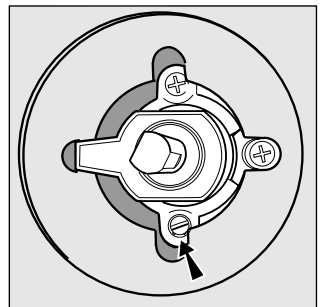
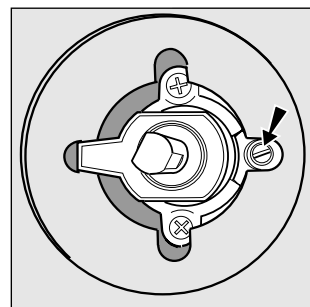

- check that the burner does not turn off **when you turn the knob from Max to Min** and when you open and close the oven door quickly.

### Adapting the gas grill to different types of gas

Replacing the nozzle of the grill burner:

- remove the screw and then slide out the grill burner “V” (see Fig. E);

- unscrew the grill burner nozzle using the special socket spanner for the nozzles (see Fig. F) or better still a 7 mm socket spanner; replace the nozzle with a nozzle for the new type of gas (see table 1).

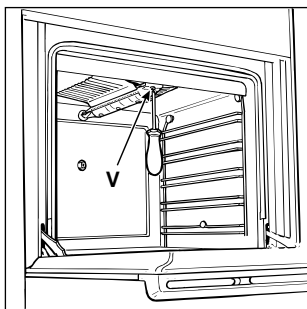

Fig. E

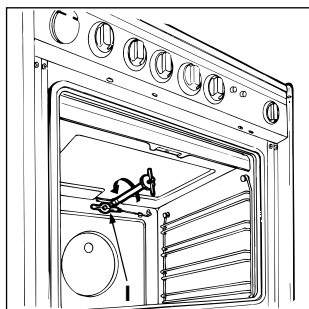

Fig. F

### **Important**

On completion of the operation, replace the old rating sticker with one indicating the new type of gas used. This sticker is available from our Service Centres.

### **Note**

Should the pressure of the gas used be different (or vary) from the recommended pressure, it is necessary to fit a suitable pressure regulator onto the inlet pipe in compliance with current National Regulations relative to "regulators for channelled gas".

# Burner and nozzle characteristics

**Table 1**

Burner	Diameter (mm)	Thermal Power kW (p.c.s.*)		Liquid Gas				Natural Gas	
				By-Pass 1/100 (mm)	Nozzle 1/100 (mm)	Flow* g/h		Nozzle 1/100 (mm)	Flow* l/h
						***	**		
Nominal	Reduced								
Fast (Large)(R)	100	3,00	0,7	41	86	218	214	116	286
Semi Fast (Medium)(S)	75	1,90	0,4	30	70	138	136	106	181
Auxiliary (Small)(A)	55	1,00	0,4	30	50	73	71	79	95
Oven	-	2,60	1,0	52	78	189	186	119	248
Grill	-	2,50	-	-	80	182	179	122	238
Supply Pressures	Nominal (mbar)					28-30	37	20	
	Minimum (mbar)					20	25	17	
	Maximum (mbar)					35	45	25	

- \* At 15°C and 1013 mbar- dry gas
- \*\* Propane P.C.S. = 50,37 MJ/Kg
- \*\*\* Butane P.C.S. = 49,47 MJ/Kg
- Natural P.C.S. = 37,78 MJ/m<sup>3</sup>

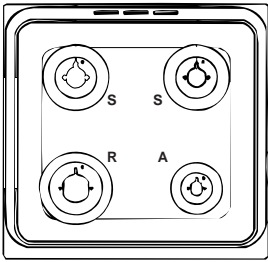

**K6G21/G**  
**K6G210/G**



# Technical Characteristics

## Inner dimensions of the oven:

Width: 43.5 cm  
Depth: 43.5 cm  
Height: 31 cm

## Inner Volume of the Oven:

58 lt

## Innder dimensions of the plate plate warmer:

Width: 46 cm  
Depth: 42 cm  
Height: 8.5 cm

## Voltage and Frequency of Power Supply:

see data plate

## Burners:

adaptable for use with all the types of gas indicated on the data plate



## This appliance conforms with the following European Economic Community directives:

- 73/23/EEC of 19/02/73 (Low Voltage) and subsequent modifications;
- 89/336/EEC of 03/05/89 (Electromagnetic Compatibility) and subsequent modifications;
- 90/396/EEC of 29/06/90 (Gas) and subsequent modifications (only for models which use gas);
- 93/68/EEC of 22/07/93 and subsequent modifications.
- 2002/96/EC

The European Directive 2002/96/EC on Waste Electrical and Electronic Equipment (WEEE), requires that old household electrical appliances must not be disposed of in the normal unsorted municipal waste stream. Old appliances must be collected separately in order to optimise the recovery and recycling of the materials they contain and reduce the impact on human health and the environment. The crossed out "wheeled bin" symbol on the product reminds you of your obligation, that when you dispose of the appliance it must be separately collected. Consumers should contact their local authority or retailer for information concerning the correct disposal of their old appliance.

## Mains frequency and voltage of the electric section and characteristics of the gas section

Model	Gas section		Electric section
	Class	Rated power kW (1)	Voltage
K6G21/G K6G210/G	II2H3+	10,40 (756 g/h - G30) (743 g/h - G31)	220-240V~ 50/60Hz

(1) The values in g/h refer to the capacities with liquid gas (Butane, Propane).

# The cooker with gas oven and gas grill

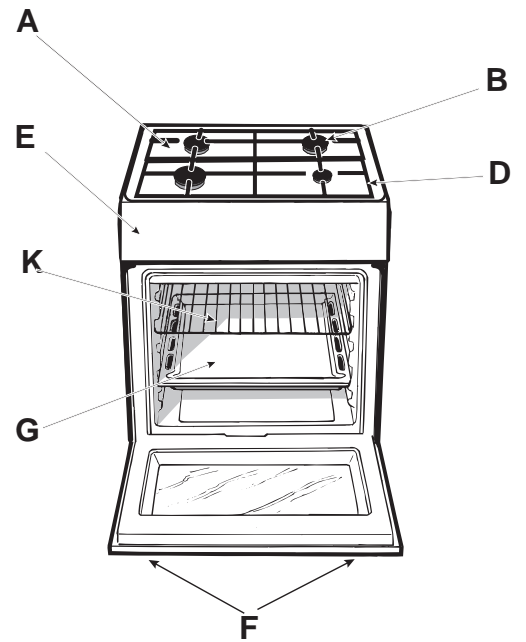
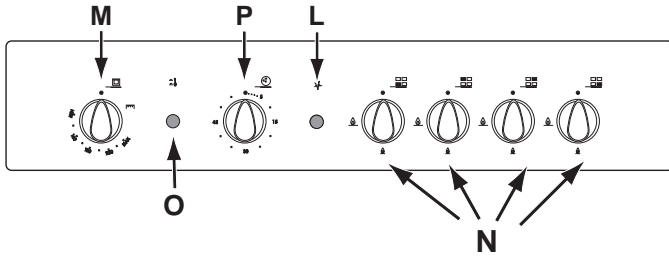
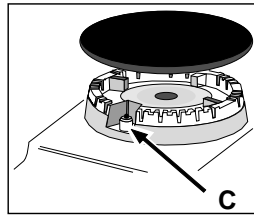

- A** Tray for Catching Overflows
- B** Gas Burner
- C** Instantaneous Electronic Lighting Device
- D** Top Grate
- E** Control Panel
- F** Adjustable Feet or Legs
- G** Dripping Pan or Baking Sheet
- K** Oven Rack

- L** Electronic Lighting for Hob Burners
- M** Oven and Grill Control Knob
- N** Control Knobs for Gas Burners on Hob
- O** Button for Oven and Rotisserie Light (only on a few models)
- P** Timer Knob

# The different functions and uses of the oven

The various functions included in the cooker are selected by operating the control devices located on the cooker control panel.

## Control Knobs for the Gas Burners on the Hob

The position of the gas burner controlled by each one of the knobs is shown by a symbol of a solid ring: ●. To light one of the burners, hold a lighted match or lighter near the burner. Press down and turn the corresponding knob in the counter-clockwise

direction to the **maximum** 🔻 setting. Each burner can be operated at its maximum, minimum or intermediate power. Shown on the knob are the different symbols for off ● (the knob is on this setting when the symbol lines up with the reference mark on the control panel), for **maximum** 🔻 and **minimum** 🔺.

To obtain these settings, turn the knob counter-clockwise with respect to the off position. To turn off the burner, turn the knob clockwise until it stops (corresponding again with the ● symbol).

## Electronic Lighting of the Hob Burners

Some models are equipped with instant electronic lighting of the gas burners located on the hob, which can be identified by the presence of an igniter device (see detail C). This device is activated by lighting pressing on the "L" button, identified by the ★ symbol. To turn on a burner, simply press the "L" button and then press while, at the same time, pressing in and turning the control knob for the burner in the anticlockwise direction until the burner lights. **To light the burner immediately, it is recommended that the button be pressed first and then the knob turned.**

**Caution: If the burner accidentally goes out, turn off the burner using the knob and wait at least one minute before relighting.**

**Notice:** The first time you use your appliance, we recommend that you set the thermostat to the highest setting and leave the oven on for about half an hour with nothing in it, with the oven door shut. Then, open the oven door and let the room air. The odour that is often detected during this initial use is due to the evaporation of substances used to protect the oven during storage and until it is installed.

**Attention:** Only use the bottom shelf of the oven when using the rotisserie to cook (where present). For all other types of cooking, never use the bottom shelf and never place anything on the bottom of the oven when it is in operation because this could damage the enamel. Always place your cookware (dishes, aluminium foil, etc. etc.) on the grate provided with the appliance inserted especially along the oven guides.

## The oven and grill knob (M)

This knob is used to select the different functions of the oven and choose the right cooking temperature for the food to be prepared in the oven among the temperatures shown on the knob (from **Min** to **Max**).

To light the oven burner, hold a lighted match or lighter near hole "F" and turn the oven knob counter anti clockwise up to the **Max** position.

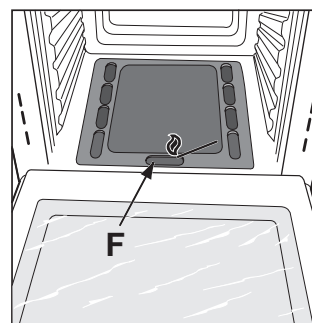

**The models equipped with a safety device on oven burner, the knob must be kept pressed in for about 6 seconds to activate the flame failure device. (For the models provided with electronic lighting see the relative paragraph).**

The cooking temperature is selected by matching the desired temperature with the permanent reference on the panel; the complete range of temperatures is shown below:

Min	•	160	•	180	•	220	Max
150	155	170	200	250			

The selected temperature is reached automatically and it is kept constant by the knob-controlled thermostat.

**To use the grill,** turn the knob clockwise till to setting |▽▽▽|, after holding a lighted match or a lighter close to the grill burner.

**In the grill burner equipped with a safety device, the knob must be held pressed in for about 6 seconds in order to activate the flame failure device (for the model provided with electronic lighting see the relative paragraph).** In this way the infrared ray comes on for browning the food or cooking roast, chops, sausages, roast-beef, etc.; for grill cooking, place a drip-pan under the grill to catch the grease.

**Important:** when using the grill, the oven door must be left partly open by positioning the deflector "D" between door and panel to prevent the cooker knobs from overheating.

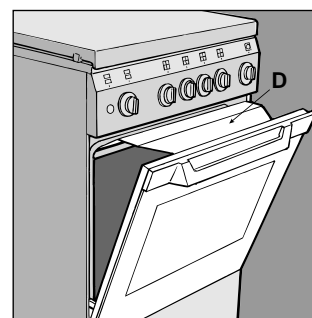

**Important Notice:** In the event the flame for the oven accidentally goes out, turn the control knob for the burner to the off position and do not relight the burner for at least one minute.

**Oven and grill electronic lighting device (L)** (only on a few models)

Some models are equipped with electronic lighting device on oven and grill.

**To light the oven gas burner** press in the botton marked by the symbol ★, press deeply and turn the oven knob clockwise, till to the position "Max".

**It is necessary to hold pressed in the knob for about 4 seconds in order to activate the flame failure device.**

**To light on the grill burner** press in the bottom marked by the symbol ★, press deeply and turn the oven knob counter clock wise till to the position |▽▽▽| (grill).



**It is necessary to hold pressed in the knob for about 4 seconds in order to activate the flame failure device.**

In case of lack of electricity light the oven or grill manual, following the instruction of "the oven knob paragraph".

#### Oven light button (O)

This is marked by the symbol  and switches on the light inside the oven so that you can control the cooking without opening the door.

#### Timer Knob (P)

In order to use the timer, it must be wound by turning the "P" knob almost one complete turn in the clockwise direction . Then, turning it back , set the desired time by lining up the number for the minutes with the mark on the control panel.

#### Practical Advice on Using the Burners

To use the burners as efficiently as possible, some basic guidelines should be followed:

- Use cookware that is the right size for each burner (see table) in order to prevent the flame from spreading beyond the bottom of the cookware.
- Only use cookware with flat bottoms.
- As soon as the boiling point is reached, turn the knob to the lowest setting.
- Always use lids with pots and pans.

Bruciatore	ø Diametro recipienti (cm)
Rapido (R)	24 – 26
Semi Rapido (S)	16 – 20
Ausiliario (A)	10 – 14

**N.B.:** On models equipped with a reduction grid, the grid should only be used with the auxiliary burner when cookware with a diameter of less than 12 cm is used.

#### Using the grill pan kit

Position the handle on the grill pan so that it fits into the small recess (fig. 1), tilt it upwards and slide it towards the centre (fig. 2).

The food must be placed on the rack in the grill pan. Position the grill pan on top of the oven rack. The best results are achieved by placing the oven rack on the uppermost shelves. Pouring a little water into the grill pan will make the collection of grease particles more efficient and prevent the formation of smoke.

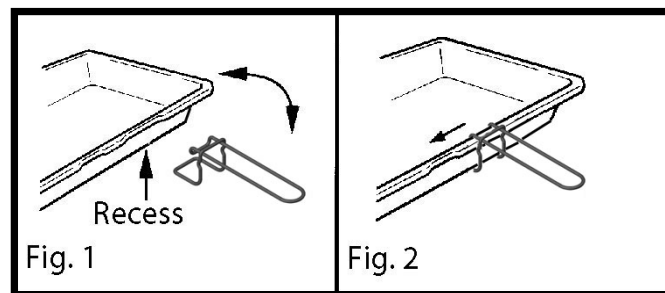

## Cooking advice

The oven offers a wide range of alternatives which allow you to cook any type of food in the best possible way. With time you will learn to make the best use of this versatile cooking appliance and the following directions are only a guideline which may be varied according to your own personal experience.

### Baking cakes

The oven should always be warm before putting in cakes wait till the end of preheating (about 15 min.). Cake-baking temperatures are normally around 160°C. Do not open the oven door during the baking process as this could cause the cake to sink.

Beaten cake mixtures should not be too soft as this could considerably lengthen cooking times. In general:

<b>Pastry is too dry</b>
Increase the temperature by 10°C and reduce the cooking time.

<b>Pastry dropped</b>
Use less liquid or lower the temperature by 10°C.

<b>Pastry is too dark on top</b>
Place it on a lower rack, lower the temperature, and increase the cooking time.

<b>Cooked well on the inside but sticky on the outside</b>
Use less liquid, lower the temperature, and increase the cooking time.

<b>The pastry sticks to the pan</b>
Grease the pan well and sprinkle it with a dusting of flour.

### Cooking fish and meat

Meat must weigh at least one Kg. to stop it becoming too dry. When cooking white meat, fowl and fish use low temperatures. (150°C-175°C). When red meat must be superficially well-cooked but succulent inside, it is advisable to start with a high temperature (200-220°C) for a short time, and then to reduce it at a later point. Generally speaking, the more meat there is, the lower the temperature and the longer the cooking time should be. Place the meat in the centre of the grid and put a spill-tray underneath to catch grease drips. Insert the grid so that it is in the middle of the oven. If more heat from below is required, use the 1° bottom shelf. For tastier roasts, wrap the meat with bacon rashers or dot the meat with lard and place it in the upper part of the oven. When some types of food are cooked in the ventilated oven (duck, rabbit, large fowl) they become too dry; in these cases, better results are obtained using the combined oven.

## Cooker routine maintenance and cleaning

**Before each operation, disconnect the cooker from the electricity.** To assure the long life of the cooker, it must be thoroughly cleaned frequently, keeping in mind that:

- **Do not use steam equipment to clean the appliance.**
- the enamelled parts and the self-cleaning panels are washed with warm water without using any abrasive powders or corrosive substances which could ruin them;
- the inside of the oven should be cleaned fairly often while it is still warm using warm water and detergent, followed by careful rinsing and drying;
- the flame spreaders should be washed frequently with hot water and detergent taking care to eliminate any scale;
- in cookers equipped with automatic lighting, the terminal part of the electronic instant lighting devices should be cleaned frequently and the gas outlet holes of the flame spreaders should be checked to make sure they are free of any obstructions;
- Stainless steel may become marked if it comes into contact with very hard water or harsh detergents (containing phosphorous) for long periods of time. After cleaning, it is advisable to rinse thoroughly and dry. It is also recommended to dry any water drops;

**Important:** periodically check the wear of the gas hose and substitute it if there are any defects; we recommended changing it every year.

### Replacing the oven lamp

- Unplug the oven from the mains;
- Remove the glass cover of the lamp-holder;
- Remove the lamp and replace with a lamp resistant to high temperatures (300°C) with the following characteristics::
  - Voltage 230V
  - Wattage 25W
  - Type E14
- Replace the glass cover and reconnect the oven to the mains.

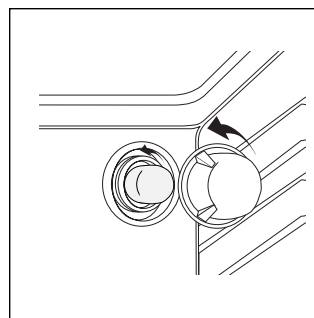

### Gas tap maintenance

The taps may jam in time or they may become difficult to turn. If so, the tap itself must be replaced.

**N.B.:** This operation must be performed by a technician authorised by the manufacturer.

Food to be cooked	Wt. (wt)	Cooking position of shelves from bottom	Temperature (°C)	Pre-heat time (min.)	Cooking time (min.)
<b>Paste</b>					
Lasagne	2,5	3	210	-	75-80
Cannelloni	2,5	3	210	-	75-80
Oven-baked noodles	2,5	3	210	-	75-80
<b>Meat</b>					
Veal	1,7	3	230	-	85-90
Chicken	1,5	3	220	-	110-115
Turkey	3,0	3	Max	-	95-100
Duck	1,8	3	230	-	120-125
Rabbit	2,0	3	230	-	105-110
Pork	2,1	3	230	-	100-110
Lamb	1,8	3	230	-	90-95
<b>Fish</b>					
Mackerel	1,1	3	210-230	-	55-60
Dentex	1,5	3	210-230	-	60-65
Trout baked in paper	1,0	3	210-230	-	40-45
<b>Pizze</b>					
Napolitan	1,0	3	Max	15	30-35
<b>Cake</b>					
Biscuits	0,5	3	180	15	30-35
Tarts	1,1	3	180	15	30-35
Chocolate cake	1,0	3	200	15	45-50
Yeast cakes	1,0	3	200	15	50-55
<b>Grill cooking</b>					
Toast	n.4	4			10
Pork chops	1,5	4			30
Mackerel	1,1	4			35

**NB:** cooking times are approximate and may vary according to personal taste. When cooking using the grill, the dripping pan must always be placed on the 1st oven rack from the bottom.

**Indesit** Company  
viale Aristide Merloni, 47  
60044 Fabriano (AN) Italy  
tel. +39 0732 6611  
[www.indesit.com](http://www.indesit.com)

Cucina con forno e grill gas (GB)  
06/05 - 195044864.01