



beyond
payment

Ingenico Unattended Product iUI120

The scope of this document is to assist third party integrators when dealing with iUI120 Ingenico Unattended product. It offers all information needed for a successful integration of iUI120 product into unattended kiosk machines.

For any sales information please refer to your Ingenico contact into the region.

Updates table

Version	Date	Nature of modifications	Author	Visa
0.1	06/02/2014	First Draft	R Alliot E.Dubois	
0.1	15/04/14	Update IC and FCC number	O.Fabregoule	

Table of contents

1	GENERAL	6
1.1	Definition of acronyms	6
1.2	iUI120 payment solution presentation	7
1.2.1	Diagram of iUI120 connectivity and communications	8
1.2.2	Services	9
1.3	Description of iUI120 product	10
1.3.1	iUI120 product views	10
1.3.2	iUI120 Technical Hardware characteristics	11
1.3.3	iUI120 output connectors description	13
1.3.3.1	Ethernet	15
1.3.3.2	USB device	15
1.3.3.3	USB host	15
1.3.3.4	COM0 link	15
1.3.3.5	COM2 link (optional)	15
1.3.3.6	MDB Slave	16
1.3.3.7	MDB master (optional)	16
1.3.3.8	Wake-Up Jack	17
1.3.3.9	Bluetooth (optional)	17
1.3.3.10	GPRS (optional)	18
1.3.3.11	SAM & μ SD Installation	19
1.3.3.12	Buzzer	20
1.3.3.13	Display	20
1.3.3.14	Maintenance Button and LED	20
1.3.3.15	iUI 120 Keypad	21
1.3.3.16	Cable Protection	22
1.3.3.17	Antenna Installation	23
1.4	Professional installation Requirement	24
1.5	Wake-UP function a revoir	25
1.5.1	Wake-up mechanism iUI120 unit	25
1.5.2	Recommended circuit implementation	26
1.5.3	Power-On sequence iUI120/iUR250/iUC150	27
2	MAIN ACCESSORIES	28
2.1.1	Generality	28
2.1.2	Optional USB cable	28
2.1.3	Serial cable	28
2.1.4	LLT cable	29
2.1.5	Stand-by management cables	30
2.1.5.1	Jack connector	30
2.1.5.2	COM0 and COM2	30
3	IUI120 SOFTWARE	31

3.1.1	Software Architecture	32
3.1.2	Secure management of software	33
3.1.3	Operating system	34
3.1.4	TELIUM MANAGER	35
3.1.5	Software downloading	37
3.1.6	Development station.....	40
4	TERMINAL MANAGEMENT SYSTEM	42
4.1	Introduction.....	42
4.2	Basic functions	42
4.3	Advanced functions	42
4.4	Customers savings with Ingenico TMS solution	42
5	INSTALLATION PROCEDURE IN KIOSKS	43
5.1	Security requirement iUI120	43
5.2	Kiosk mechanical requirements.....	Erreur ! Signet non défini.
5.3	General installation recommendations.....	44
6	ASSEMBLY PROCEDURE FOR IUI120.....	45
6.1	Kiosk minimum volume for iUI 120	45
6.1.1	Volume for iUI 120 without cable gasket.....	45
6.1.2	Volume for iUI 120 with cable gasket.....	46
	Kiosk preparation for iUI120 new installation	47
6.1	Installing the iUI120 in new kiosk.....	48
6.1.1	Left horizontal on a shelf inside the kiosk.....	48
6.1.2	Mounted vertically on a support using EVA standard recommendation	48
6.1.3	Mounted vertically on a support using bolts or studs.....	50
7	MAINTENANCE	52
7.1	Configuration	52
7.2	Operating life.....	52
8	CLEANING INSTRUCTIONS	52
9	DISASSEMBLING THE PRODUCTS ACCORDING TO WEEE DIRECTIVE	53
9.1	iUC120 End-of-life disassembly instructions	53
9.1.1	MODELS AND DESCRIPTIONS	53
9.1.2	COMPONENTS AND MATERIALS REQUIRING SELECTIVE TREATMENT	53

9.1.3	PRODUCT DISASSEMBLY PROCESS	54
10	STANDARDS	55
10.1	Electrical consumptions	55
10.2	Temperature and humidity	55
10.3	Environmental specification continued	55
10.4	EC standard compliance marking	56
10.5	IC statements	56
10.6	FCC Statement	57
10.7	Environment (WEEE, Batteries and Packaging)	58

1 GENERAL

1.1 DEFINITION OF ACRONYMS

EMC	Electro Magnetic Compatibility
EVA	European Vending Association
GND	Ground
GPRS	General Packet Radio Service
GSM	Global System for Mobile communications
LCD	Liquid Crystal Display
LLT	Local Loading Tool
MDB	Multi Drop Bus
RAM	Random Access Memory
RS232	Recommended Standard 232. A standard for serial binary communications
SAM	Secure Access Module – the chips storing the electronic cash register in a stored value scheme such as Moneo, Proton or VISA Cash.
SMA	SubMiniature version A
USB	Universal Serial Bus

1.2 IUI120 PAYMENT SOLUTION PRESENTATION

The iSelf Series is the new range of Ingenico unattended devices to offer payment into any kiosk through any segments (petrol, transport, vending, parking, etc.).

The modules for iSelf Series are:

for contactless reading, iUC150,iUC180,iUC180B

for contact and magnetic strip reading, iUR250

for PinPad entry , IUP250.

These compact devices are designed to fit everywhere, thanks to an easy installation, respectful of EVA EPS (Standard door module).

Usage can be indoor or outdoor, resisting to harsh environment.

Remarks:

- For iUC180 & iUC180B, additional peripherals can be added to build a complete solution such as printer or bar code reader. Ingenico does not provide these devices so far but they can be connected to the iUC180 & iUC180B (through USB, or RS232).
- Ingenico is also offering other iSelf Series modules dedicated to PINPad like iUP250 or Hybrid Card Reader iUR250.
- The iUC150 is the preferred contactless peripheral for the iUP250+iUR250 solution.

The iSelf Series is the next generation of Ingenico leveraging of experience from previous product ranges, i9500 series or CAD30 series, to renew your experience of unattended payment.

1.2.1 Diagram of iUI120 connectivity and communications

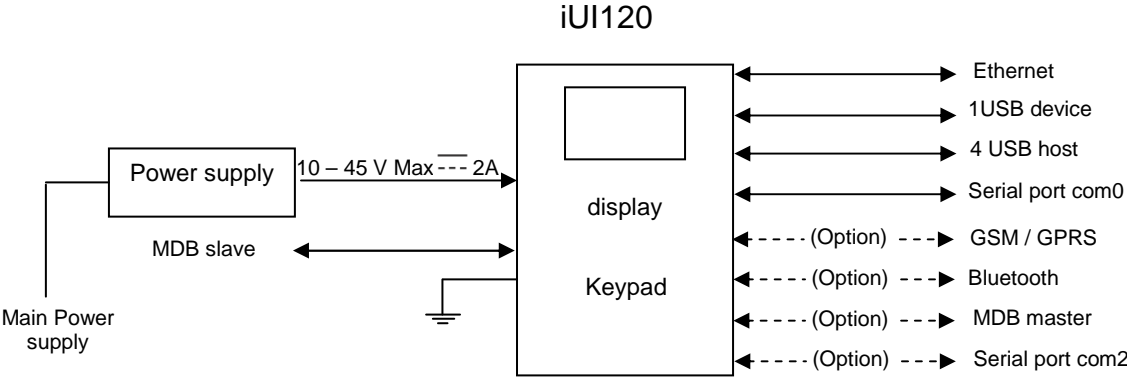

1.2.2 Services

Training	<ul style="list-style-type: none"> - Unattended - Installation and exploitation - Softwares - OEMC/M²OS development (days) - EMV Level 2 package (2 days) - Development workstation SDK
Support	<ul style="list-style-type: none"> - Hot-line support - Technical assistance
After-Sales Service	<ul style="list-style-type: none"> - Fixed cost repair of iSelf Series products
Downloading server centre	<ul style="list-style-type: none"> - User licence - Installation and commissioning - User training - Hot-line support - Technical assistance
Softwares / Licences	<ul style="list-style-type: none"> - User licence for local loading tool, LLT - User licence for applications software - User licence for M²OS - Licence for software signature tool, SAT - Licence for "EMV Level 2 package " - Licence for TCP/IP - ...

1.3 DESCRIPTION OF IUI120 PRODUCT

1.3.1 iUI120 product views

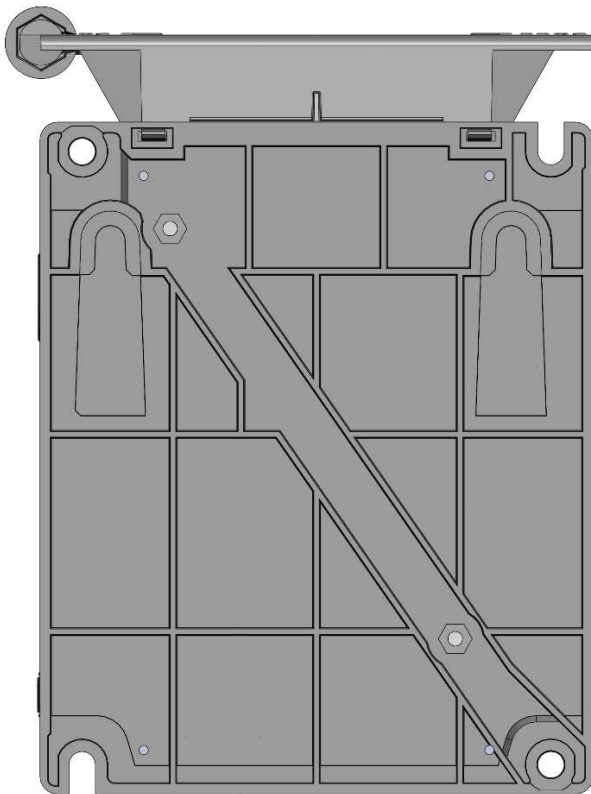

Front view



Rear view

1.3.2 iUI120 Technical Hardware characteristics

Mass	247 g
Dimensions	134 x 106 x 48 mm (height x width x depth)
Power Supply	iUI120 : 10 – 45 V Max $\overline{\text{---}}$ 2A
Platform	Telium2
Memory	16 Mb SDRAM and 128 Mb Flash
Functionality	<p>Buzzer</p> <p>RGB led internal status indicator</p> <p>1 Maintenance Button</p> <p>μSD</p> <p>2 SAM</p> <p>1 SIM (optional)</p> <p>1 Jack for wake-up</p> <p>wake-up mechanism on RS232 connectors</p> <p>Keys: 16 keys for maintenance</p> <p>128 x 64 graphic display maintenance</p>
Link	<p>Ethernet</p> <p>GSM/GPRS (optional)</p> <p>Bluetooth (optional)</p> <p>4 USB host (1.2 A total max)</p> <p>1 USB device</p> <p>2x RS232 (1 optional)</p> <p>MDB slave</p> <p>MDB Master (optional)</p>

GPRS detailed characteristics

The GPRS connection is optional in iUI120

Characteristics	GSM/ GPRS
Frequency	<p>Quad band:</p> <p>GSM (850, 900Mhz)</p> <p>DCS (1800Mhz)</p> <p>PCS (1900Mhz)</p>

Transit power	Class 4 (2W) for GSM850 / EGSM900 Class 1 (1W) for DCS1800 / PCS1900
Communication feature	Multi slot Class 10 (4+1, 3+2)
	Stay connect feature
GPRS baudrates	Downlink up to 85.6 kbps, Uplink up to 42.8 kbps

Bluetooth detailed characteristics

Characteristic	Bluetooth V2.0
Chipset	Bluecore 6
Standard compliance	Bluetooth v2.1 EDR (enhanced data rate) – Class 2
Profile	SPP Other profile to be analysed on request
Radio transfer rate	1 Mbit/s 2Mbit/s (EDR)
Number of supported links	7 slaves to 1 base
Range	Indoor: 10m typical Bluetooth Class 2 – mini 10m in free sight

Operating conditions

Functional temperature*	-20°C, +65°C
Max relative humidity	85% at 55°C, non-condensing

1.3.3 iUI120 output connectors description

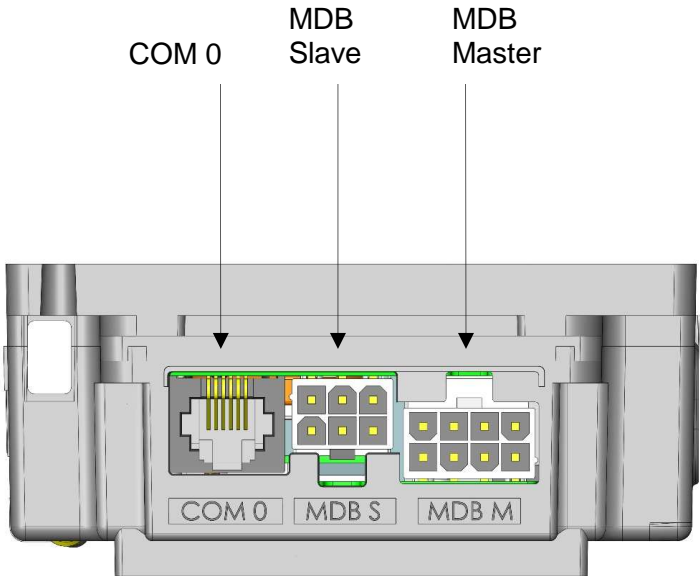

Top view

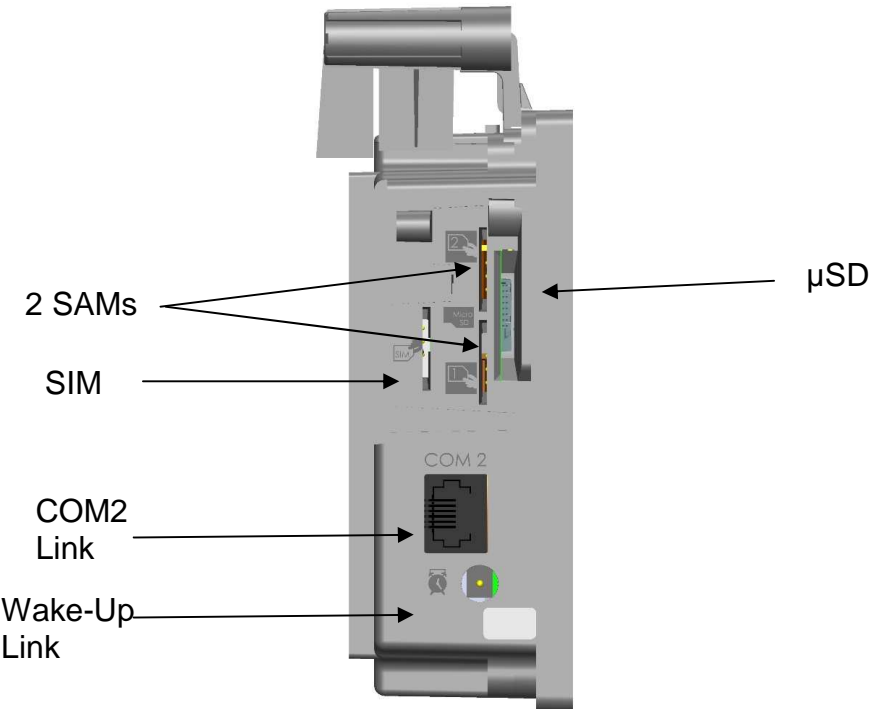

Right view

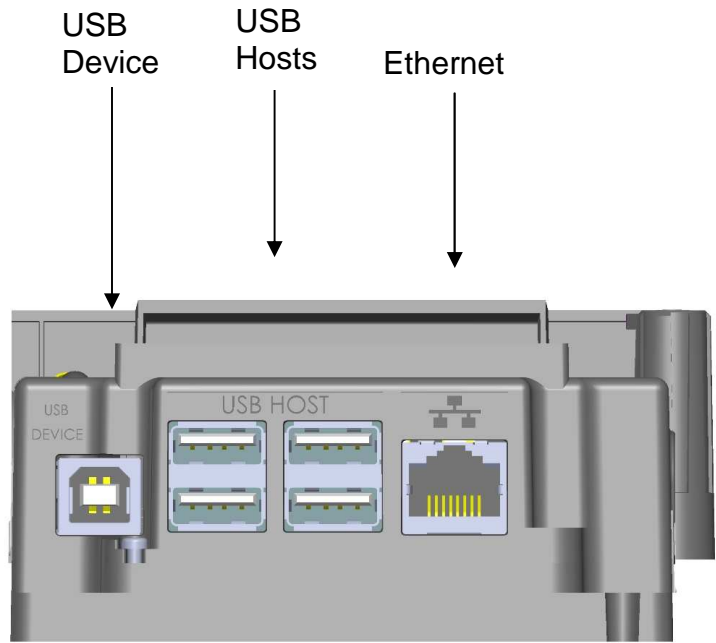

Bottom view

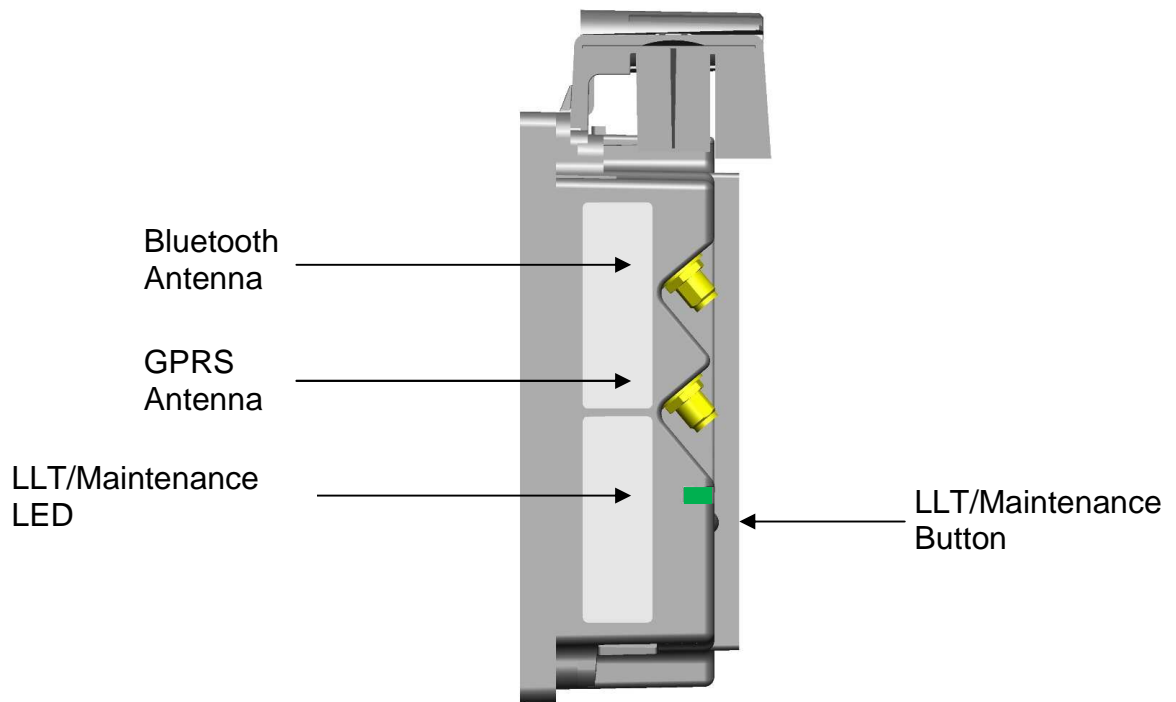

Left view

1.3.3.1 Ethernet

The iUI120 unit can be connected to Ethernet. The connector type is shielded RJ45. The Ethernet cable is standard and not provided. The Ethernet cable must be shielded.

1.3.3.2 USB device

The iUI120 unit can be connected by type B USB.

1.3.3.3 USB host

The iUI120 unit can drive 4 USB accessories. The connector is standard type A. The power available is limited to 1.2A Max dispatched between the 4 USB.

1.3.3.4 COM0 link

The iUI120 unit can be connected to serial port COM0. The connector type is RJ11.

Pin N°	Function
1	GND
2	Wake-up
3	RXD
4	TXD
5	CTS
6	RTS

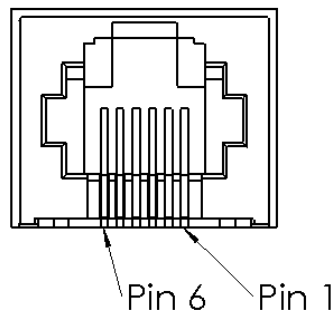

1.3.3.5 COM2 link (optional)

The iUI120 unit can be connected to serial port COM2 if the option is available. The connector type is RJ11.

Pin N°	Function
1	GND
2	Wake-up
3	RXD
4	TXD
5	CTS
6	RTS

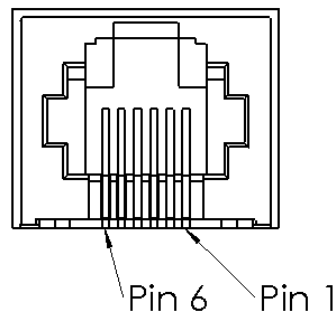

1.3.3.6 MDB Slave

iUI120 unit can be connected by MDB slave. The connector type is MDB 6 pins (Mini – Fit series 87827 (MOLEX)).

iUI120 unit is powered on the MDB connectors by power supply 10 to 45V DC (45V is a maximum).

Pin N°	Function
1	Vin
2	GND
3	NC
4	MDBS_RXD
5	MDBS_TXD
6	MDBS_COMMUN

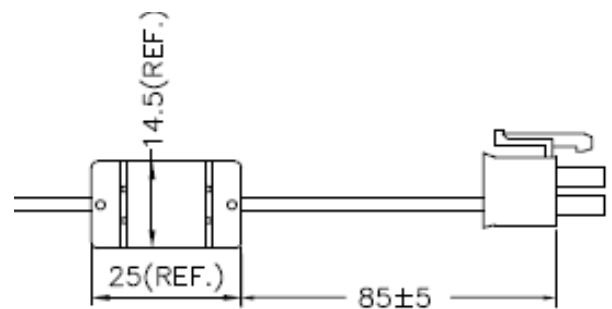
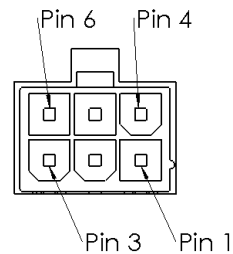

A Würth ferrite ref 74270077 or equivalent must be added on the power cable.

1.3.3.7 MDB master (optional)

The iUI120 unit is powered on the MDB connectors by power supply 10 to 45V DC (45V is a maximum). See below iUI120 unit can be connected by MDB master if option available. The connector type is MDB master 8 pins (Mini – Fit series 87827 (MOLEX)).

iUI120 unit does not support EXE power supply. Specific accessory are available.

A Würth ferrite ref 74271222 or equivalent must be added with two turns on the cable.

Pin N°	Function
1	NC
2	NC
3	NC
4	NC
5	MDBM_RXD
6	ISO_GND
7	MDBM_TXD
8	ISO_GND

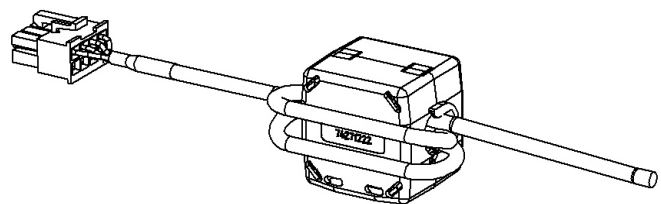
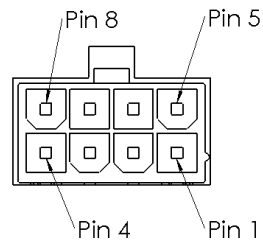

1.3.3.8 Wake-Up Jack

This connector is used for Wake-up mechanism.

Pin N°	Function	
1	GND	
2	HZ	Stand-by authorized
	"0"	Wake-up / Stand-by unauthorized

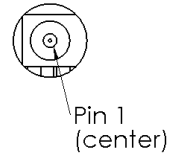

WARNING :

The specific jack and cable is a spare part, contact commercial service to purchase it.
Warning: do not plug-in a DC power in the jack. It could damage the iUI120.



1.3.3.9 Bluetooth (optional)

When the iUI120 unit is ordered with Bluetooth option, it must be connected to an external Bluetooth antenna.

Ingenico can provide an antenna, or a standard one can be used. This standard Antenna must have an impedance of 50 Ohm and a maximum gain of 0 dBi.

Ingenico recommended antennas:

Antenna type	manufacturer	model	gain	impedance	Minimum cable length	Ingenico Reference

bipolar	EAD	FBTS35024-SM-ST	0dBi	50ohm	0	192023282
---------	-----	-----------------	------	-------	---	-----------

1.3.3.10 GPRS (optional)

When iUI120 product is provided with GPRS functionality (configuration upon request), the external antenna is not provided with the unit.

Ingenico can provide an antenna, or a standard one can be used. This standard Antenna must have an impedance of 50 Ohm and a maximum gain of 3.5 dBi.

The SIM used for GSM functionality must be assigned to SIM slot.

Ingenico recommended antennas:

Antenna type	manufacturer	model	gain	impedance	Minimum cable length	Ingenico Reference
bipolar	AMPHENOL	90-00234	1.7dBi	50ohm	0	179900131
bipolar	HIRSHMANN	MCA 18 90 MP	2.1dBi	50ohm	2.5m	189968573
bipolar	Giga concept	GC300M-011-2500	2.2dBi	50ohm	2.5m	189963487

1.3.3.11 SAM & μ SD Installation

1. Disconnect the iUI120 unit from the main power supply.
2. Open the SAM door by removing the screw.
3. Insert the SAM cards in SAM slot 1 and /or slot 2
4. Insert μ SD card in μ SD slot
5. Insert SIM card in SIM slot.
6. Slide the SAM door and screw.

SAM cover
Screwed with M2X6 T6

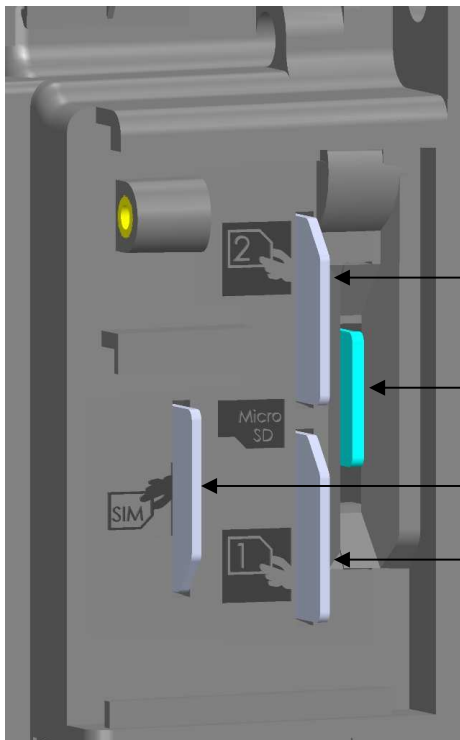

SAM2 Slot

μ SD Slot

SIM Slot

SAM1 Slot

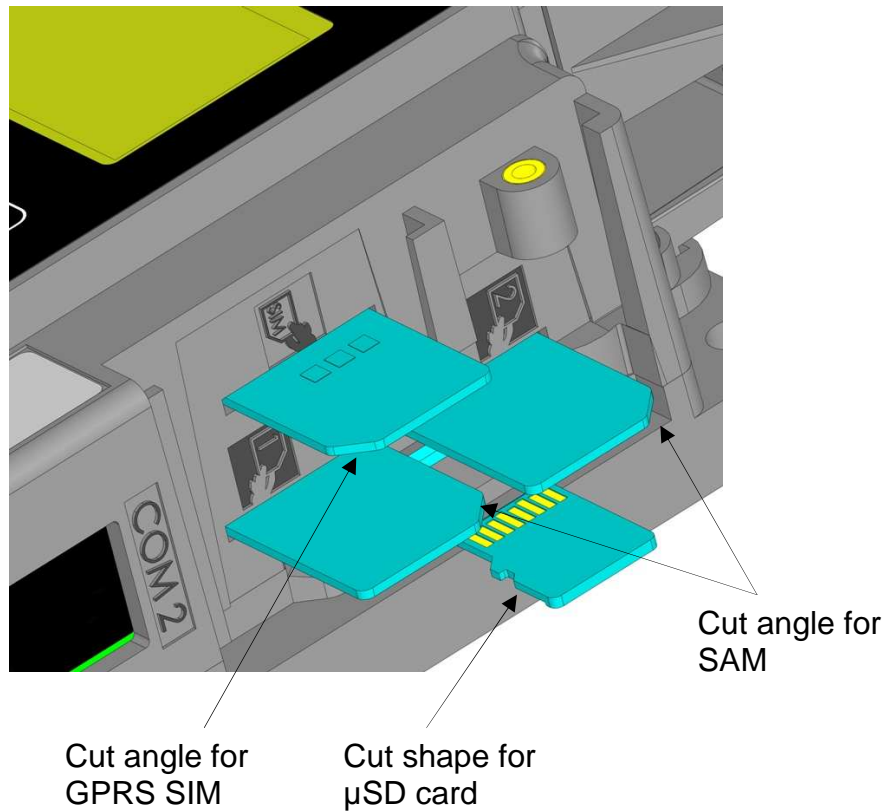

For SAM/SIM cards, take care of cards orientation and do not push in excess the cards.
 After insertion, the cards position is 4 mm out of the products as shown on picture.

1.3.3.12 Buzzer

The buzzer is controlled by application. The frequency depends of software.

1.3.3.13 Display

The iUI120 have a black and white display.

1.3.3.14 Maintenance Button and LED

The iUI120 unit has a maintenance button at the back.

- To enter LLT mode, press the button at power up or at restart, until the red LED lights on.
- To enter Maintenance mode, press the button at power up or at restart, until the red LED starts blinking.
- To restart the product, press the button until the blue LED lights on.

1.3.3.15 iUI 120 Keypad



Remarks:

The rear display and the keyboard can only be used in maintenance mode.
“*” and “.” are used for Up and Down.

1.3.3.16 Cable Protection

A cable sealing sleeve is provided with iUI120 unit to protect the top of product against water runoff.

Connect the cables, and snap in the part on the rear cover to cover the cables. This sleeve also holds the antenna tool for GPRS and BT options.

Proposed position for cables:



Cable sealing sleeve clipped on back cover

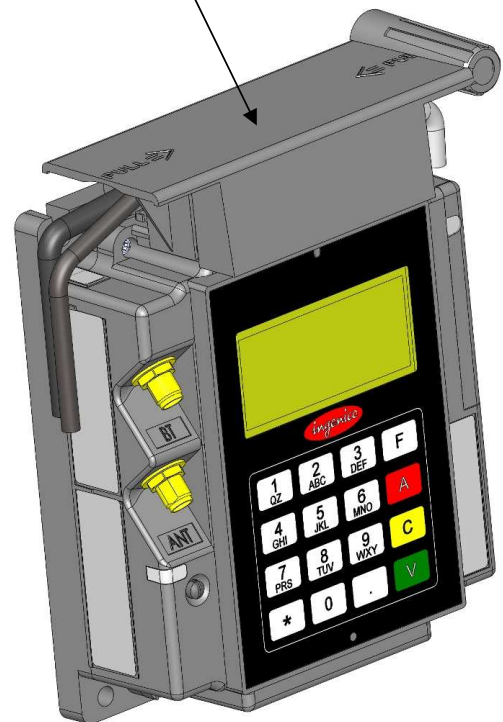

1.3.3.17 Antenna Installation

A tool is provided to help screwing the external antenna.

1. Remove the antenna tool from the cable sleeve.
2. Insert the SMA antenna cable through the slot of the antenna tool.
3. Slide the antenna tool over the SMA Cable connector.
4. Screw the cable.

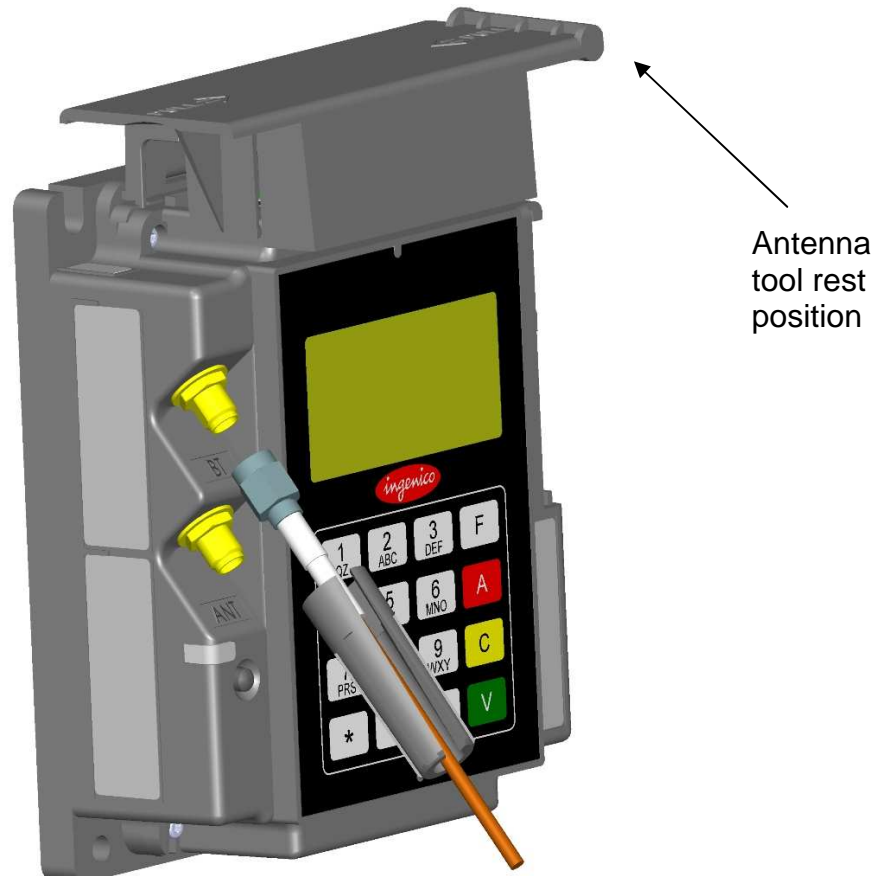

1.4 PROFESSIONAL INSTALLATION REQUIREMENT

Ingenico only sells its products, to qualified partners and integrators. They are in charge of professionally resell, integrate, and install these products inside complete solution for end customers.

These end customers solution can be:

- Petrol station.
- Ticketing kiosk (Airline tickets, cinema, transport, etc.)
- Vending machine operator
- Parking kiosk (On / off street)
- Other

Thus, the general public cannot purchase Ingenico hardware or software.

Partners, resellers, and Integrators must have qualified electronics engineers to be able to install or integrate our products. Furthermore, they must follow a specific technical training conducted by Ingenico technical experts.

In addition installation must follow Ingenico recommendations, as describe in this document, in order to respect:

- Local regulations for Electrical Safety and Radio emission levels
- Ferrite beam installation

Our field support & maintenance engineers are available for follow up and commissioning of installation.

1.5 WAKE-UP FUNCTION A REVOIR

1.5.1 Wake-up mechanism iUI120 unit

iUI120 unit is designed to save power thanks to a “stand-by mode”.

If the stand-by mode is used, use Wake-up mechanism:

- with button connected on jack (optional)
- with Pin 2 of COM0 link & COM2 link
- by pressing the green key on the maintenance keyboard.

Wake-up pin state	
Hz (high impedance)	Stand-by authorized
Drive to “0”	Wake-up / Stand-by unauthorized

The Wake-up pin is drive to “0” by the one asking the wake-up.

It could be driven by iUR250 or any devices designed to be compliant (Host device...).

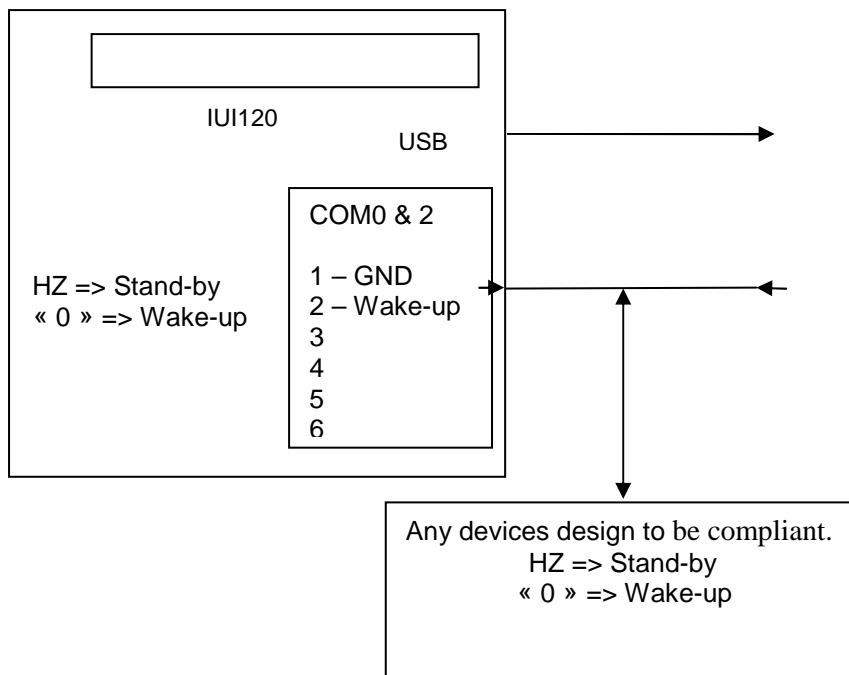

1.5.2 Recommended circuit implementation

Warning:
Voltage on this pin must not exceed 10V

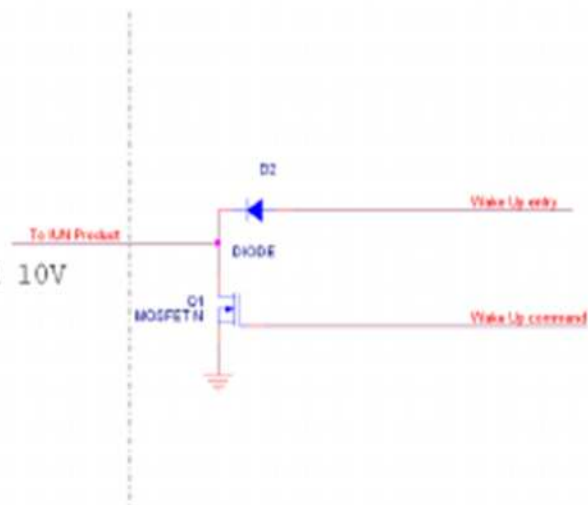

The wake up pin must be high Impedance. Do not connect directly any voltage on this pin. The devices are 10 volts tolerant on this pin but it is recommended to be High impedance. The voltage on this pin must not exceed 10 volts in any case. As the pin is high impedance in stand by mode, any current leakage can wake up the product so please be careful to choose component with ultralow leakage current for wake up circuit.

1.5.3 Power-On sequence iUI120/iUR250/iUC150

This configuration describes the worst case for wake-up timing.

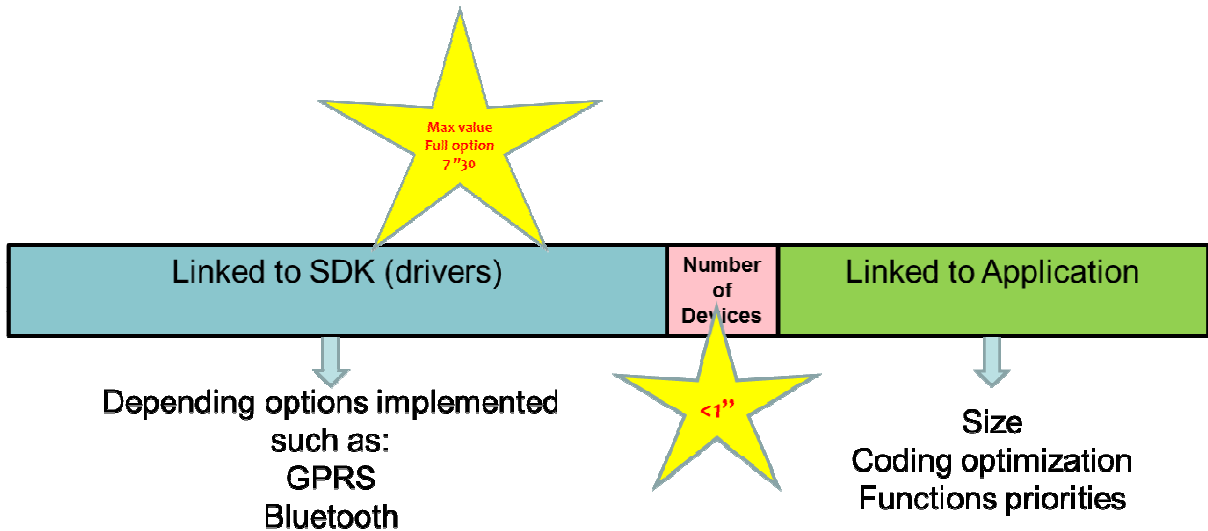
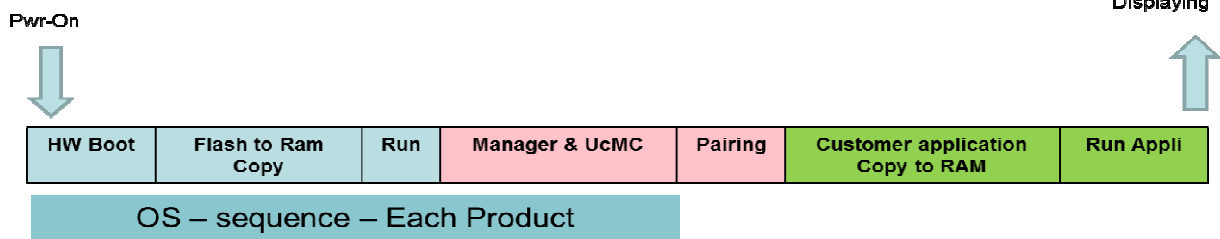
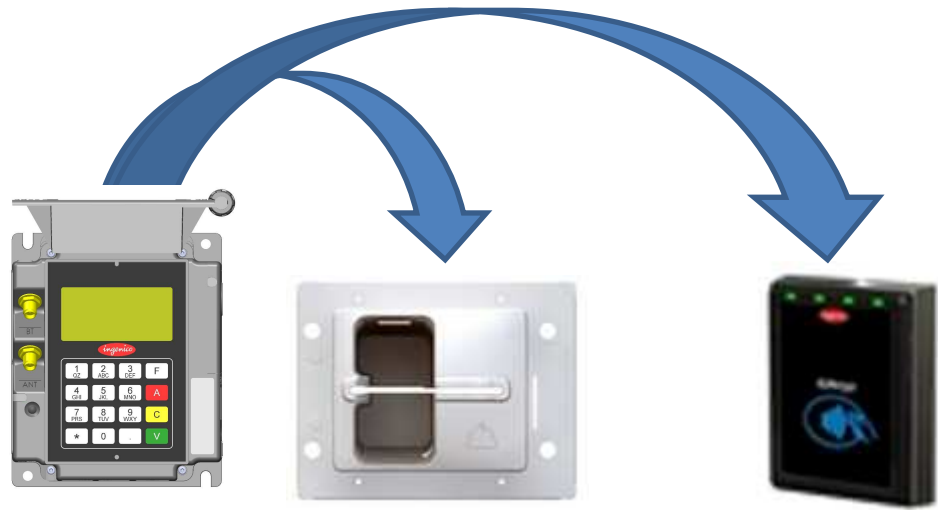

2 MAIN ACCESSORIES

2.1.1 Generality

For a complete description of Ingenico Accessories, please refer to iselfseries accessories catalog.

2.1.2 Optional USB cable

An optional USB cable (spare part reference 296129367) with short right-angle overmolded connectors can be purchased as an accessory. This cable is designed to optimize the required volume for iUI120 installation in the kiosk and allows the use of the cable sleeve.

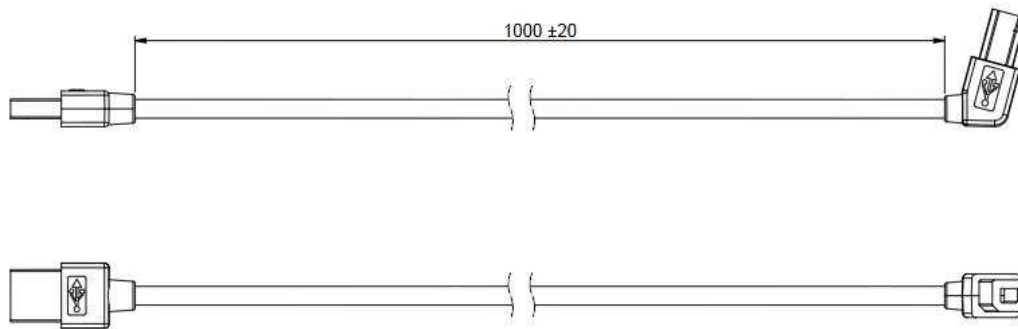

2.1.3 Serial cable

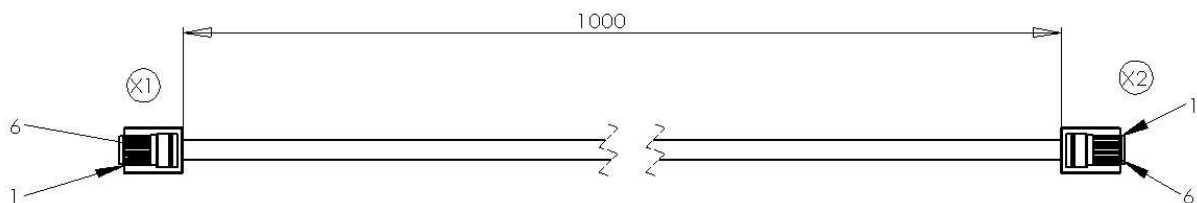



Reference	Drawing/spec	Material	Hardness	Color
X1 and X2	Modular plug 6-6 adapted for round cable			

Gauge	Comments	Departure	Outline	Arival	Comments	Gauge
		X1		X2		
AWG28	GND	1		1	GND	
	CTS	2		2		
AWG28	RTS	3		3	RXD	
AWG28	RX	4		4	TXD	
AWG28	TX	5		5	CTS	
	VCC	6		6	RTS	

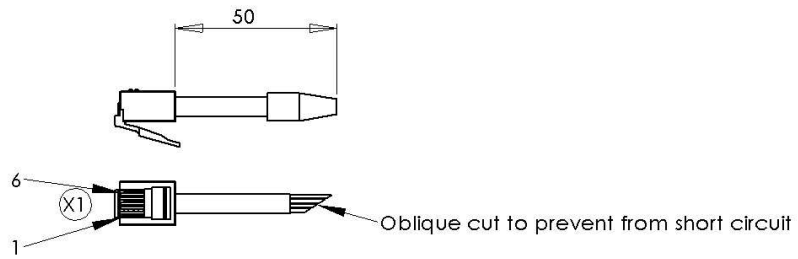
2.1.4 LLT cable



Reference	Drawing/spec		Material	Hardness	Color
X1	Modular plug 6-6 adapted to cable profile				
Gauge	Comments	Departure	Outline		
		X1			
	GND	1			
	Wake-up	2			
	RXD	3			
	TXD	4			
	CTS	5			
	RTS	6			

2.1.5 Stand-by management cables

2.1.5.1 Jack connector

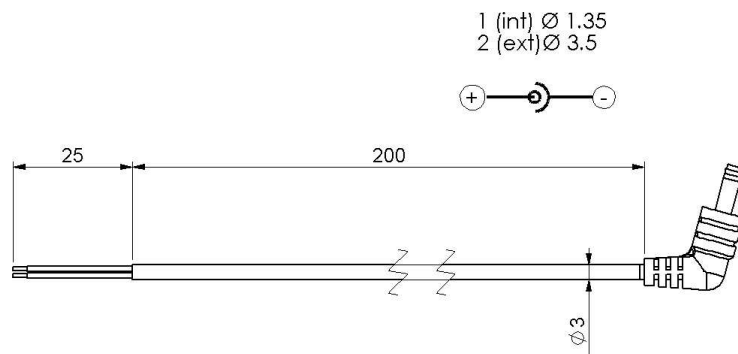

Wire reference mark	Length (mm)	Comments	Departure point	Outline	Arrival point	Comments
					J1	
AWG 22		+		=====	1	+
AWG22		GND		=====	2	GND

Definition of the jack connector:

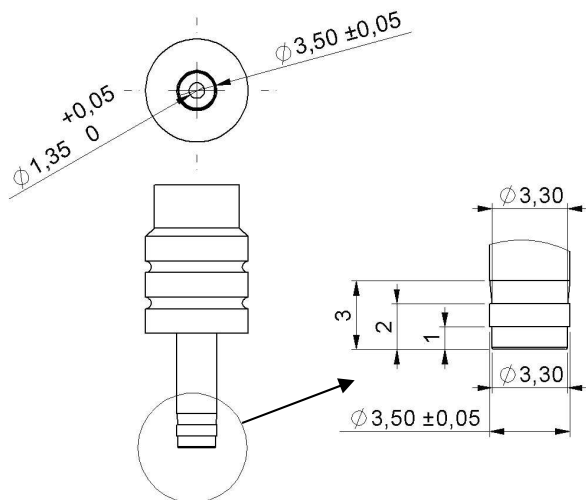

2.1.5.2 COM0 and COM2

Specification available on demand.

3 IUI120 SOFTWARE

The system unit, equipped with Telium2[®] technology, is designed with a structure supporting several applications without any mutual interference.

The operating system is a multi-task, real time, preemptive system.

The inputs and outputs are managed by interrupts.

This provides for simultaneous processing of peripherals, thus increasing system unit performance.

It is downloadable to FLASH memory.

3.1.1 Software Architecture

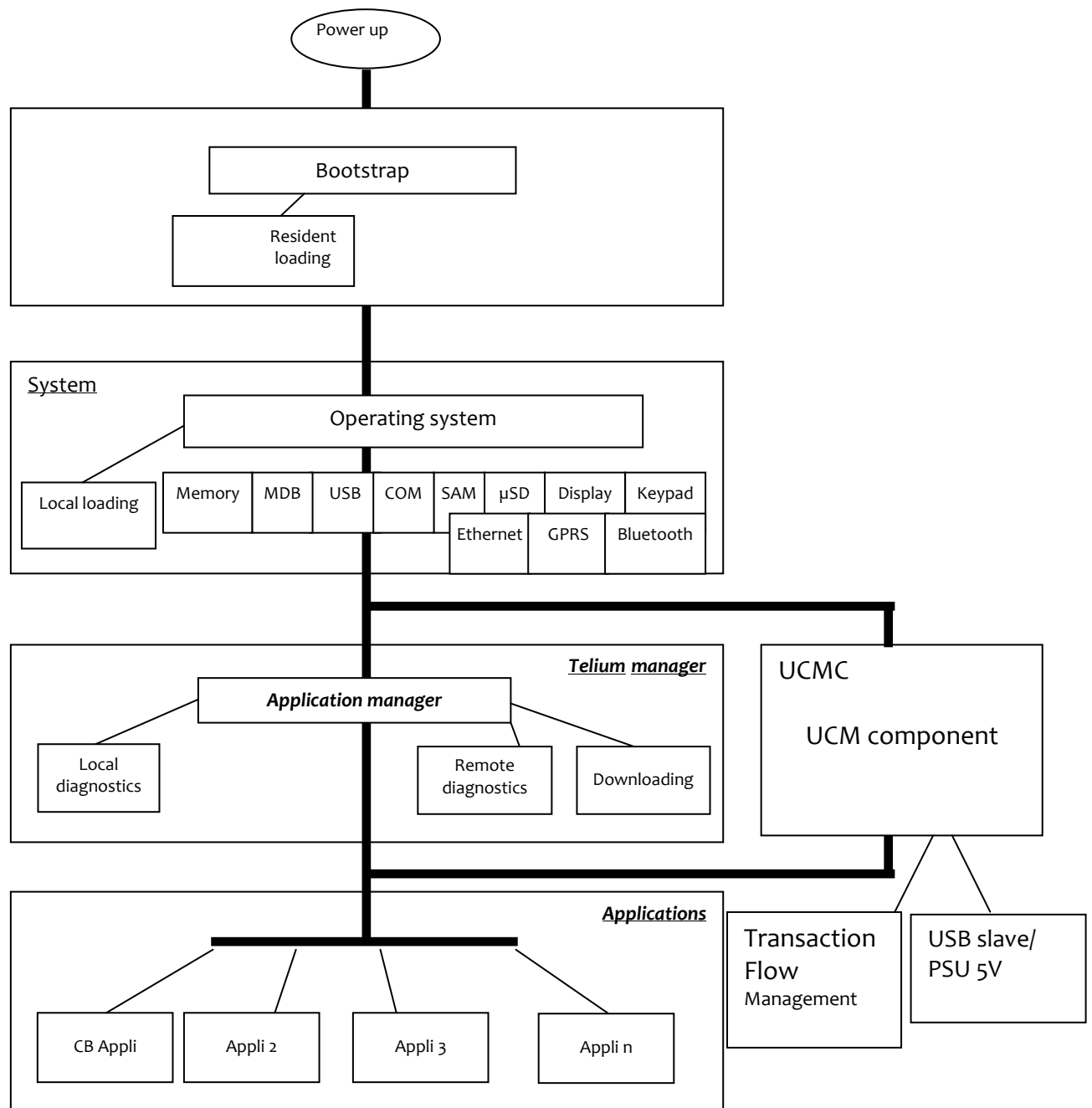

The software architecture is divided into levels:

- System
- Multi-application manager
- Universal Controller Module Component (UCMC)
- Independent applications

The system manages access to all the terminal's peripherals. Access is achieved through standard C primitives for all the input/output peripherals (keypad...) and through specific primitives for the other peripherals (smart cards and magnetic stripe cards). Further, the system takes charge of memory management. It allocates memory space to the software applications and access control.

The multi-application manager is the entity, which calls the various applications downloaded in the terminal in response to the various events that occur in the terminal.

The UCMC component interfaces between the applications and the peripherals (PINPad, Reader, Printer...). This makes the applications independent of the peripherals.

It can also manage the « transaction flow ».

The applications are modelled around the demands made by the multi-application manager. Each request or input point represents a processing operation to be performed. Each application manages the execution of these processing operations according to its specifications. This standardization based on input points simplifies the implementation of the applications on terminals. The terminal provides natural access to the modularity concepts and improves the maintainability and quality of the applications.

3.1.2 Secure management of software

The terminal is designed to execute authentic software only and to do this in a ranked context.

The terminal performs the following checks:

1. During a software download, the terminal checks :
 - Its authenticity, by checking its signature with the RSA algorithm with a 2048 bit key.
2. Before running a software, the terminal checks :
 - Its presence by looking for the software's identity.
 - Its integrity by checking checksums and CRCs.

3.1.3 Operating system

Bootstrap

Bootstrap is resident.

The bootstrap very briefly takes control of the terminal after each power up to perform the initialization and the self-test. Then, it automatically runs the operating system, which in turn starts the applications manager.

Thus, the Bootstrap provides the following functionalities:

- Memory and checksum self-test
- Local download of the operating system if absent
- Operating system authenticity check and start-up.

Operating system characteristics

The operating system is downloaded (locally or remotely) into the memory. It is upgradeable. After a few fractions of a second following a power-up, the operating system takes control. It checks the presence, integrity and authenticity of the system components and application software present in the terminal.

The maintenance sub-system takes control in the following cases:

- if no authentic application is present,
- or, if a manual action is made by the operator during power up,
- or, if it is activated by an application.

The maintenance sub-system ensures, among other things, the downloading of the application software.

The operating system ensures the start of the multi-task core and then runs the applications by making a set of services available to them:

- Multi-task management: Availability of a pre-emptive real-time environment, based on interruptions, events and mailboxes. This management enables simultaneous processing, which improves the terminal's performance.
- Input/Output management: This is carried out under interruptions, generally in buffered mode. Thus, the application developer enters a "conventional" C context.
- System alarm management: Certain incidents detected by the operating system are recorded. They can be used later by the maintenance sub-system during remote or local diagnostics.
- Application alarm management: A number of incidents detected by the applications can be saved by the operating system at their request. This recording is used later as in the case of system alarms.
- Application isolation management: The operating system provides the mechanisms described in the section on software isolation and memory protection.
Inter-application isolation is managed by the Memory Management Unit (MMU).
- Application download management: The operating system offers the downloading services described in the « Software download » section.

3.1.4 TELIUM MANAGER

The main functions offered by the manager are the following:

- Application management
- Terminal initialization
- Terminal maintenance
- Card Recognition and routing to the applications

When the EMV DC module is present, it selects the applications:

- EMV applications (EMV level 2 compliant)
- Non-EMV applications

In France, it is compatible with the following environments

- Health system
- French banking system
- "Private applications"

Terminal initialization

Required operating conditions

To operate, the system unit has to be equipped with its system, the application manager, the UCMC and at least one application.

If no application is initialized, the application manager displays a message requesting initialization for an application (in maintenance mode).

If at least one application is initialized, the terminal is operational. The application manager then waits for an event to poll the applications loaded in the terminal.

Initialisation of common parameters (in maintenance mode)

The application manager is used to initialize the common parameters:

Date, time, message display language, IP network configuration data, local loading or remote diagnostics.

System unit maintenance (in maintenance mode)

The system unit has maintenance functions.

- Properties
- Local downloading
- Diagnostics

Properties

The properties function is used to obtain the following information:

- List of applications loaded in terminal, version number, checksum, etc. The application manager gives this information for itself and for the operating system.
- Application call time: remote collection, loading, etc.
- Total number of transactions in each application file contained in system unit.

Download

The downloading function uses the information supplied on initialization of the application manager.

The program update function is used to update the system unit by:

- Using a special local loading tool connected to the terminal,
- Using a remote loading tool,
- Using a USB key. The iUI120 must be in maintenance mode with a USB key containing the software to load plugged in. Then, launch the download by using the manager menu

Diagnostics

The diagnostics function is used for:

- Local diagnostics
The operator can request the incidents or alarms stored in the terminal.

The storage function implements two sets of elements:

- Incident counters: Used for « repetitive » incidents, for which only the number of occurrences is significant. For example, number of power on.
 - Events: Exceptional in nature. The information content depends on the type of incident. Generally, this comprises the date, time and information relative to the incident itself. The events are stored in a rotating file where the most recent events are kept.
- Remote diagnostics
This function is used by the operator to trigger a call to a server to dump the information stored in the terminal. The server thus enriches a database by which it can efficiently monitor a terminal population, or propose services such as preventive maintenance, operating statistics, etc.
 - Diagnostics by USB key
Diagnostic files are copied to a USB key if present at start-up.
 - Note :

Displaying Bluetooth & GPRS information at the same time is not possible on iUI120.

In maintenance mode it's possible to display one information or the other by pressing "0" key

By default, GPRS info is displayed.

3.1.5 Software downloading

Downloading

The software can be downloaded:

- Locally via the serial link (COM or USB).
- Remotely, via the switched telephone network (PSTN) using an external modem, Ethernet, GPRS, TCP/IP network.
- By a USB key. The iUI120 must be in maintenance mode with a USB key containing the software to load plugged in. Then, launch the download by using the manager menu.

The techniques used:

- Data compression,
 - Authenticity checking,
 - Memory allocation management,
 - TCP/IP,
- best optimize the software downloading operations.

These features provide faster downloading time, enhanced security, an ease in upgrading, and a larger number of software installed on the system unit.

Local Loading Tool (LLT)

The LLT is used for local software download.

The LLT is formed by:

- A PC running with Windows Seven, Vista Pro, XP, 2003 Server, 2000 Professional SP2
- A INGENICO loading software,
- A PC-terminal connecting cable

Local loading is performed:

- From a PC equipped with the Local Loading Tool (LLT) on the COM serial or slave USB link
- By automatic switching to the local loader of the operating system.

Two connections are possible:

- By COM link: Speed 115200 bits/s
- By slave USB link: Speed 8 Mbits/s approx.

Selection of the software to be loaded is guided on the PC screen by an Explorer type Windows system (Windows loader).

Loading time for a 1Mo application is 4s by USB port.

Loading by USB key

With the USB key loading method, the software is loaded locally with no need for a PC type tool.

The loading time is identical to that of the USB.

Terminal Management Server (TMS)

For a complete description of the TMS possibilities, refer to the "TMS" section.

Loading and management of memory space in system unit

Before a (down)load, the system ensures that the necessary memory space is available.

The software (possibly compressed) are downloaded to flash.

If software is deleted, the system frees the space. If software is upgraded, the system loads the new software, checks it, and deletes the old version.

The entire memory area is used and is usable. No area is reserved for upgrades.

On start-up of the terminal (power up or reset), the applications are decompressed and the code is copied to RAM.

Improved software downloading

Includes the following characteristics:

Softwares are loaded by FTP TCP/IP and PPP for optimized loading.

- Downloading performance in V32bis is around 1.4 kbps on the original files.
- Once the connection is set up with the V32bis modem, a 120 Kbytes application is downloaded in around 1 minute.
- Automatic dialling and access to downloading server by switched telephone network (STN) or by X25 (TRANSPAC, in France) using a public PAD or private PAD access.
- Downloading can be performed in IP mode via Ethernet via a secure channel (SSL).
- Data is compressed in accordance with an algorithm derived from the Lempel-Ziv method ensuring compression rates of the order of 40 %.
- For downloading, only the improved application will be downloaded. This management function is handled by the system unit itself and not by the remote server, providing enhanced functional security in a multiple source loading context.
- Recovery management in the event of loss of communication. This service resumes the downloading which has been interrupted at the exact location where the interruption took place, so that only the missing portion is downloaded when the communication is recovered.

The downloaded software is run in a secure context by authenticity check.

Downloading Starting

The downloading can be requested:

- Using the application manager on maintainer request. This is the case, in particular, where a program upgrade is concerned or when a new software is added in the terminal memory. In this case, the procedure is simplified to the utmost.

The user triggers the call from the application manager by choosing the upgrade function in the menus and using the dialogue keys. Connection to the server takes place automatically.

For an upgrade, the user has nothing to enter.

To request a new software, the user is guided on the screen in making his choice.

The identity of the business is not requested. The identity stored in the system unit is automatically transmitted to the server.

- Using the application software on request by the center or merchant (Example: in France, by « envelopes").
In this case, downloading takes place entirely automatically. The downloading ticket informs the merchant.

Local loading procedure on:

Trigger the LLT software on the PC
Switch off the product
Connect the PC to the COM or slave USB connector.
Press the rear button and switch on the iUI120.
When the LED near the button becomes fix red, release the button. "LLT" text is now displayed on screen.
Trigger the LLT and follow the instructions given in the « LLT User's guide v4 » to load the software.

The parameter definition files must be placed in the "HOST" directory.

3.1.6 Development station

Introduction

With this development station, it is possible to develop application software for the entire range of iUN products.

The software is written in high level C language in a multi-application environment. Ingenico provides the complete set of software and the equipment required for development. This also includes the documentations. Training sessions can also be proposed.

Required Configuration

The development station executes on a Pentium PC running under Windows 2000/XP/Vista/Seven.

Development tools for ARM such as a cross-compiler are required. These comprise:

- A C compiler (GNU), an assembler and a link editor for ARM and Thumb,
- A development environment,
- A remote debugger.

Supply

The SDK 30 development station comprises:

- The user license for the M²OS software which includes:
 - The operating system,
 - The application manager,
 - The libraries
 - The associated documentation in PDF format
- The user license for the Software Authentication Tool (SAT) software,
- The user license for the Local Loading Tool (LLT),
- The card reader and the RSA cards used to sign the applications.

SDK + Add On Unattended

For iUI120: minimum configuration SDK 9.18 and Add-On Unattended 4.6 are required

Associated services

- Training

Development of applications on iUN

Duration: 1 day

Location: R&D center.

- Pre-requisites for training:

A good understanding of the C language is required. Familiarity with firmware can be useful.

- Technical support

Duration: 6 months after the training

This includes the hot line, and updates to the documentations and softwares during this period.

- Software package

A set of software packages, used to simplify development of applications (EMV level 2, ...) is available.

4 TERMINAL MANAGEMENT SYSTEM

4.1 INTRODUCTION

Ingenico developed its own Terminal Estate Management System called IngEstate. It is a link between an organisation with an estate of payment terminals and their merchants. It allows users to remotely manage payment terminals, modify their software content and interact with merchants.

4.2 BASIC FUNCTIONS

The basic functions are:

- be able to locally download software on a terminal using a direct cable link (usually RS232);
- be able to remotely download software on a particular terminal using modems and IP connections;
- be able to remotely download applications and configuration updates to a large estate of terminals;
- be able to upload terminal configurations and check software status;
- Be able to inform merchants when terminals are out of use during maintenance periods.

4.3 ADVANCED FUNCTIONS

The advanced functions are extremely various, with new ones being requested frequently:

- draw statistics and reports about terminal configurations;
- optimise automatic call scheduling/download balancing for large estates of terminals;
- be able to display written messages on the terminal, using the display or the printer;
- be able to easily configure a complete terminal (i.e. several applications) and to download it in one operation;
- be able to analyse the status of terminal software and do only delta downloads (i.e. only the parts that are damaged or need updates);
- be able to download to either a Peripheral or a terminal when connected;
- Customise the system easily;
- Integrate with systems such as SAP easily;
- ... and many others.

4.4 CUSTOMERS SAVINGS WITH INGENICO TMS SOLUTION

The most obvious cost saving is not having to send a technician to service the terminal at the merchant location. Many other costs savings are derived from the ability to have a “clean” estate; better diagnostics and remote software repairs mean less shipping of replacement terminals, less downtime, less mail and phone communication costs, more efficient update campaigns, etc.

5 INSTALLATION PROCEDURE IN KIOSKS

Note: It is required to use **ESD-protective clothing** while handling these devices.

5.1 SECURITY REQUIREMENT IUI120

Your device fulfils current applicable PCI PTS security requirements.

Upon receipt of your terminal you should check for signs of tampering of the equipment. It is strongly advised that these checks are performed regularly after receipt. You should check, for example: that the keypad is firmly in place; that there is no evidence of unusual wires that have been connected to any ports on your terminal or associated equipment, the chip card reader or any other part of your terminal. Such checks would provide warning of any unauthorised modifications to your terminal, and other suspicious behaviour of individuals that have access to your terminal. Your terminal detects any “tampered state”. In this state the terminal will repeatedly flash the message “Alert Irruption!” and further use of the terminal will not be possible. If you observe the “Alert Irruption!” message, you should contact the terminal helpdesk immediately.

You are strongly advised to ensure that privileged access to your terminal is only granted to staff that have been independently verified as being trustworthy.

The terminal must never be put in or left at a location where it could be stolen or replaced by another device.

5.2 GENERAL INSTALLATION RECOMMENDATIONS

Installation requirements:

- Ensure that you have enough free space for installation, operational and maintenance needs.
- Be aware of the safety regulations.
- Carefully consider the general and local payment security requirements and any impact they may have on the kiosk.
- Carefully consider the ergonomic aspects and also the local acts or recommendations concerning disabled and visually impaired people.
- See environmental specification and especially in case of very cold or humid weather, take steps to ensure that the internal temperature is at least -20 °C.

6 ASSEMBLY PROCEDURE FOR IUI120

6.1 KIOSK MINIMUM VOLUME FOR IUI 120

The iUI120 requires a minimum volume inside the kiosk. It is detailed in the drawings below. 3D design is available on demand.

6.1.1 Volume for iUI 120 without cable gasket

The minimum volume is 95.4 mm width x 115 mm height x 43 mm deep.

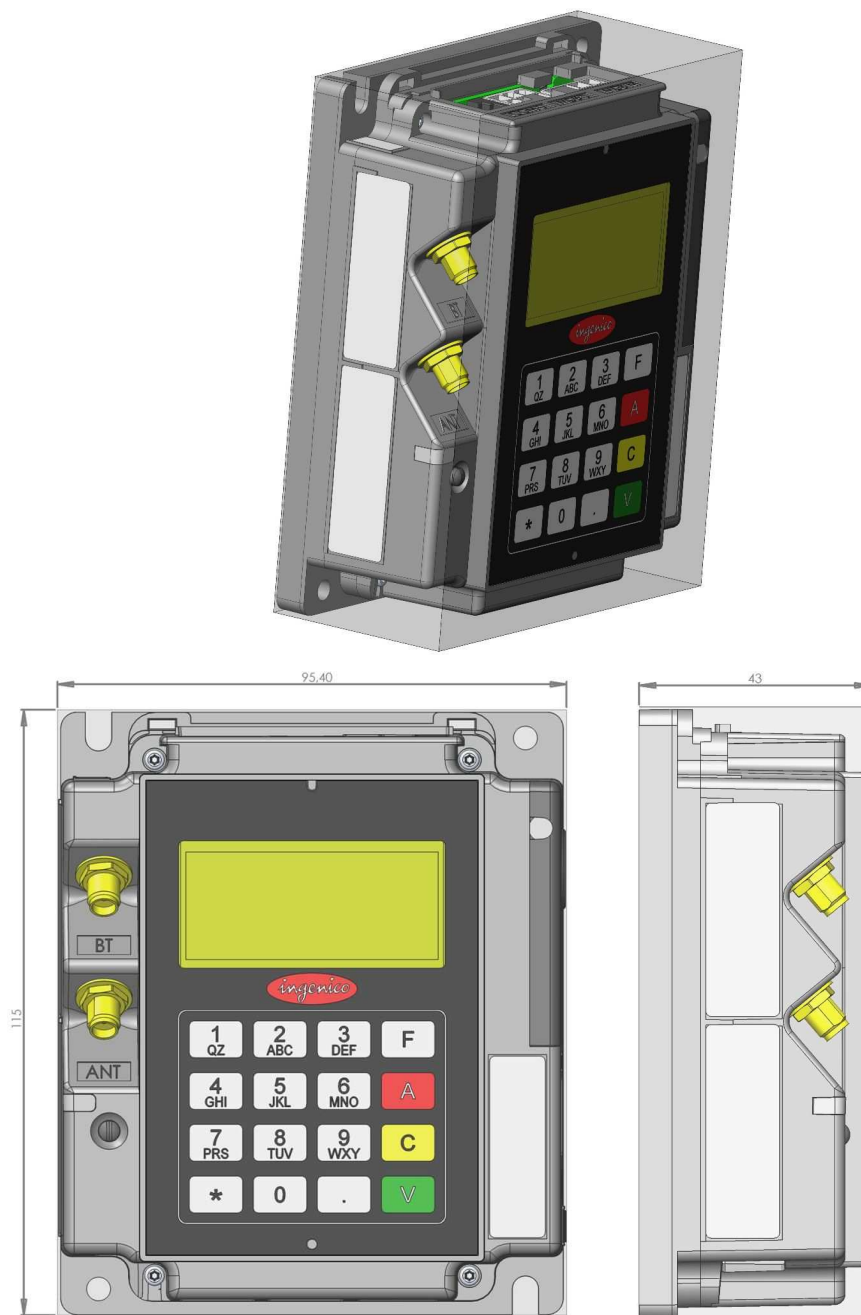

Picture of iUI 120 without cable gasket minimum volume

6.1.2 Volume for iUI 120 with cable gasket

The minimum volume is 101mm width x 135 mm height x 49 mm deep.

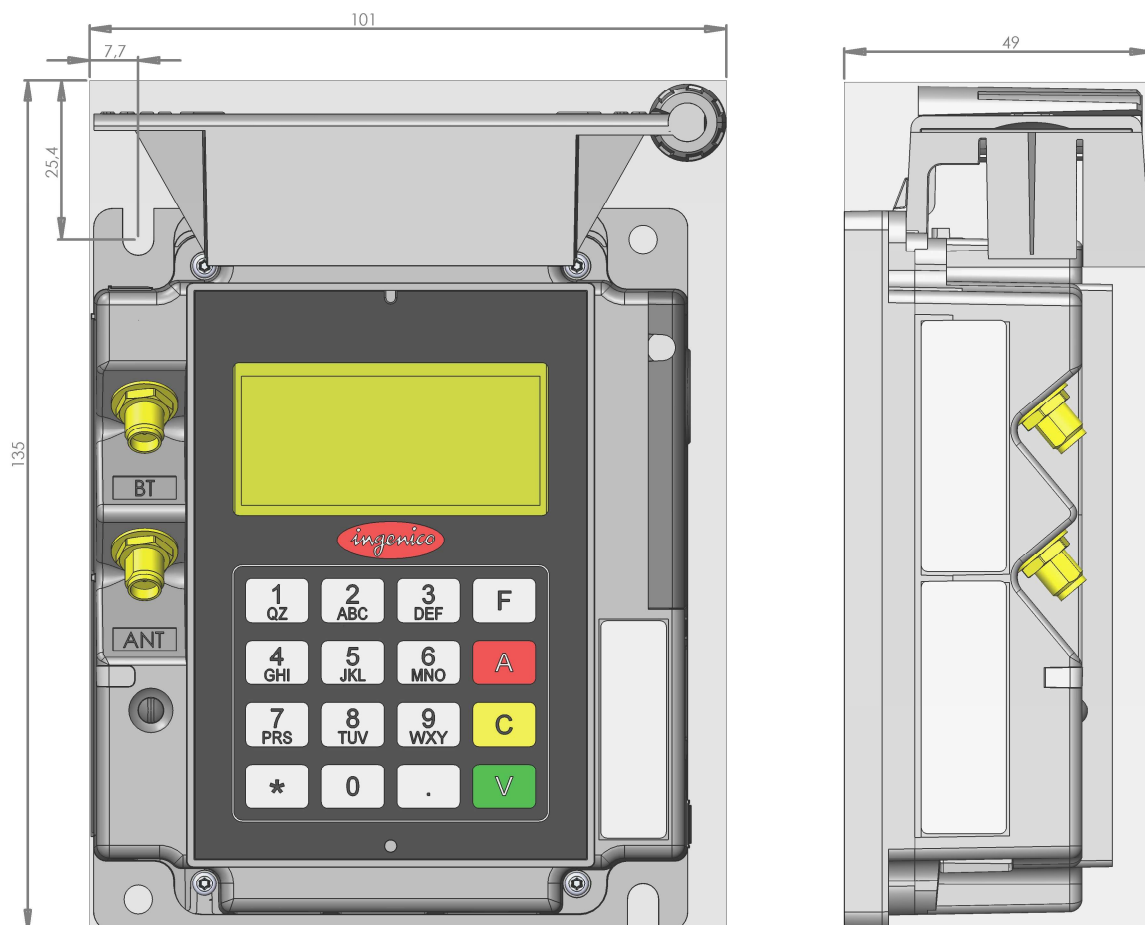

Picture of iUI 120 with cable gasket minimum volume

KIOSK PREPARATION FOR IUI120 NEW INSTALLATION

IUI120 can support 3 different mounting ways:

- Left horizontal on a shelf inside the kiosk
- Mounted vertically on a support following EVA standard recommendation
- Mounted vertically on a support using bolts or studs

3D step files are also available upon request.

6.1 INSTALLING THE IUI120 IN NEW KIOSK

6.1.1 Left horizontal on a shelf inside the kiosk

For this configuration, there is no specific recommendation.

6.1.2 Mounted vertically on a support using EVA standard recommendation

EVA recommends using 2 M4 cap bolts distant 68.4 mm to hold internal products. In addition, we suggest making a M4 holes to lock the iUI120 with a screw.

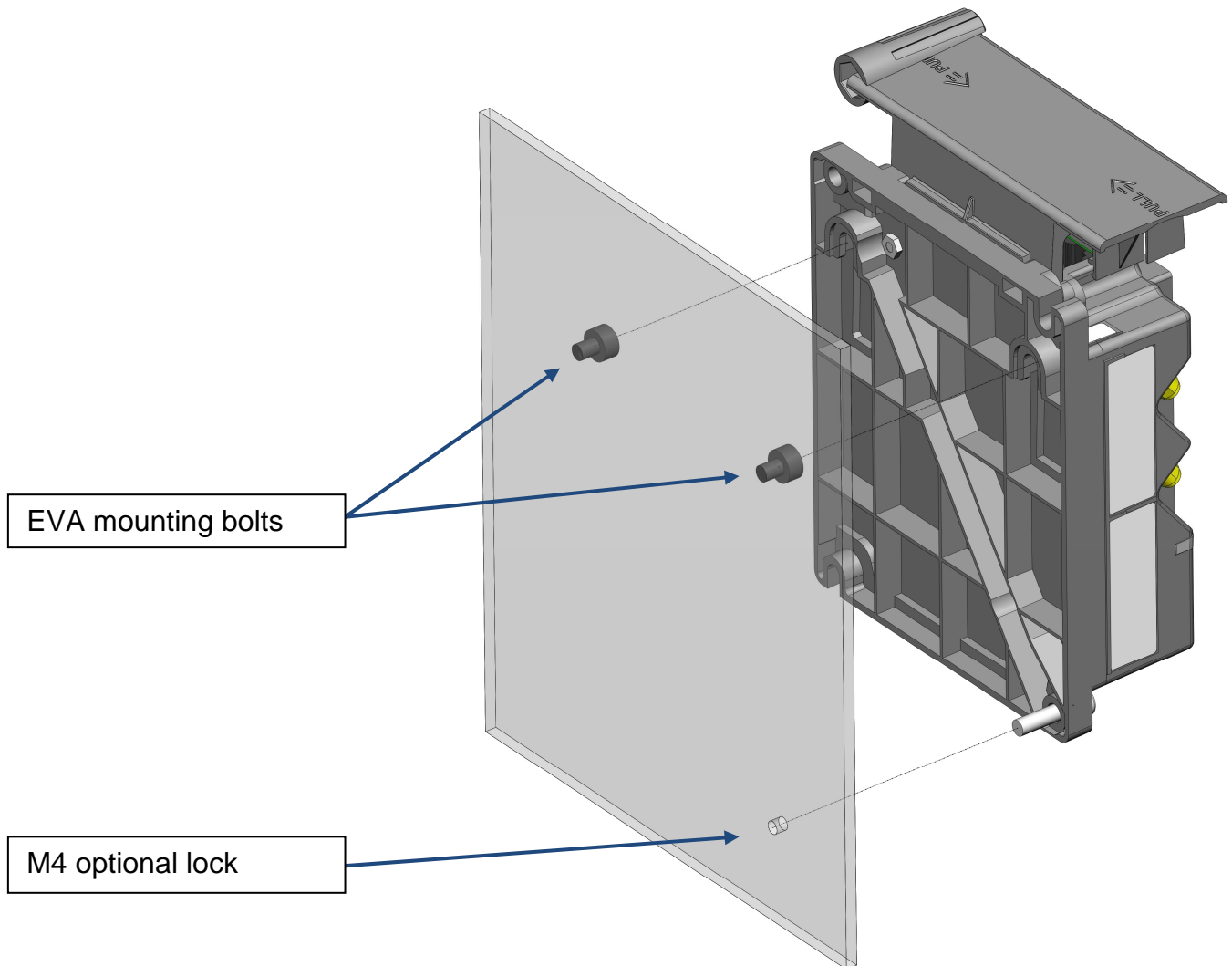

Details of EVA mounting

EVA M4 cap bolts. Can be weld or screwed on the kiosk.

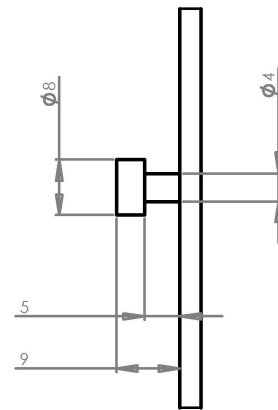

Dimensions on the iUI120 regarding position of the receptacles for EVA M4 bolts.

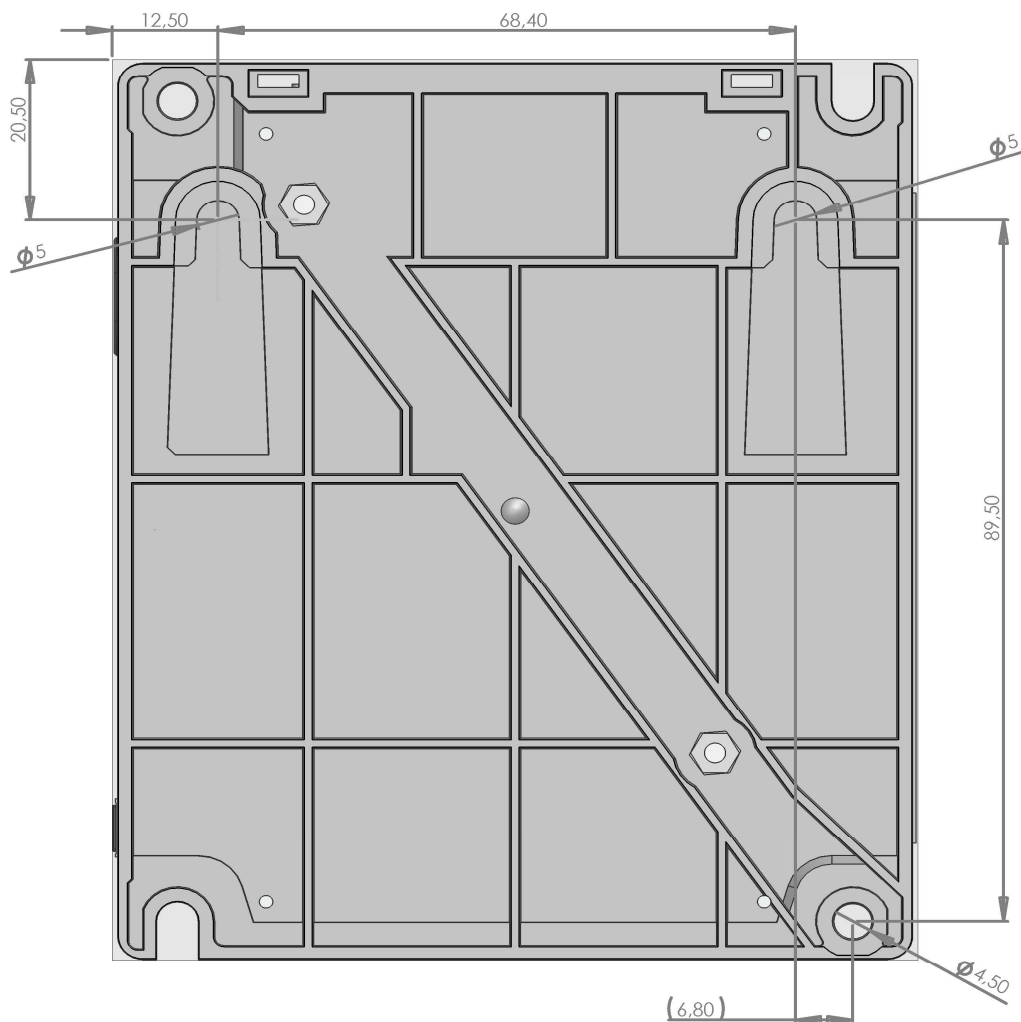

Picture showing a new installation of the iUI120

6.1.3 Mounted vertically on a support using bolts or studs

Common installation may consider to use 2 weld studs or bolts. We suggest using 2 diagonally opposite slots out of the 4 of iUI120.

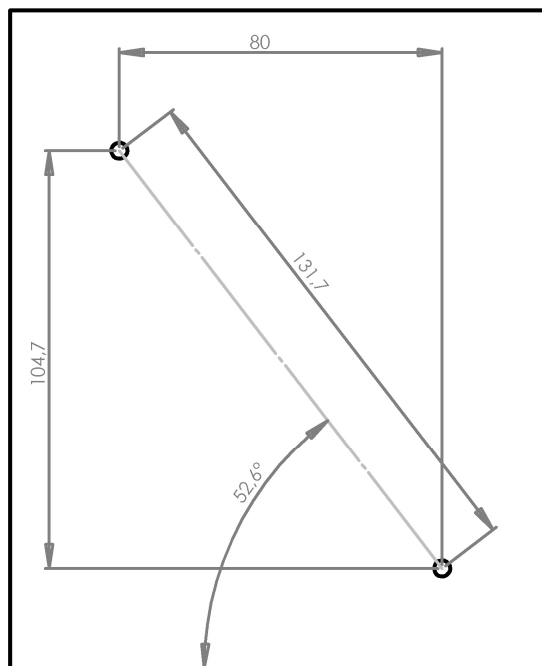
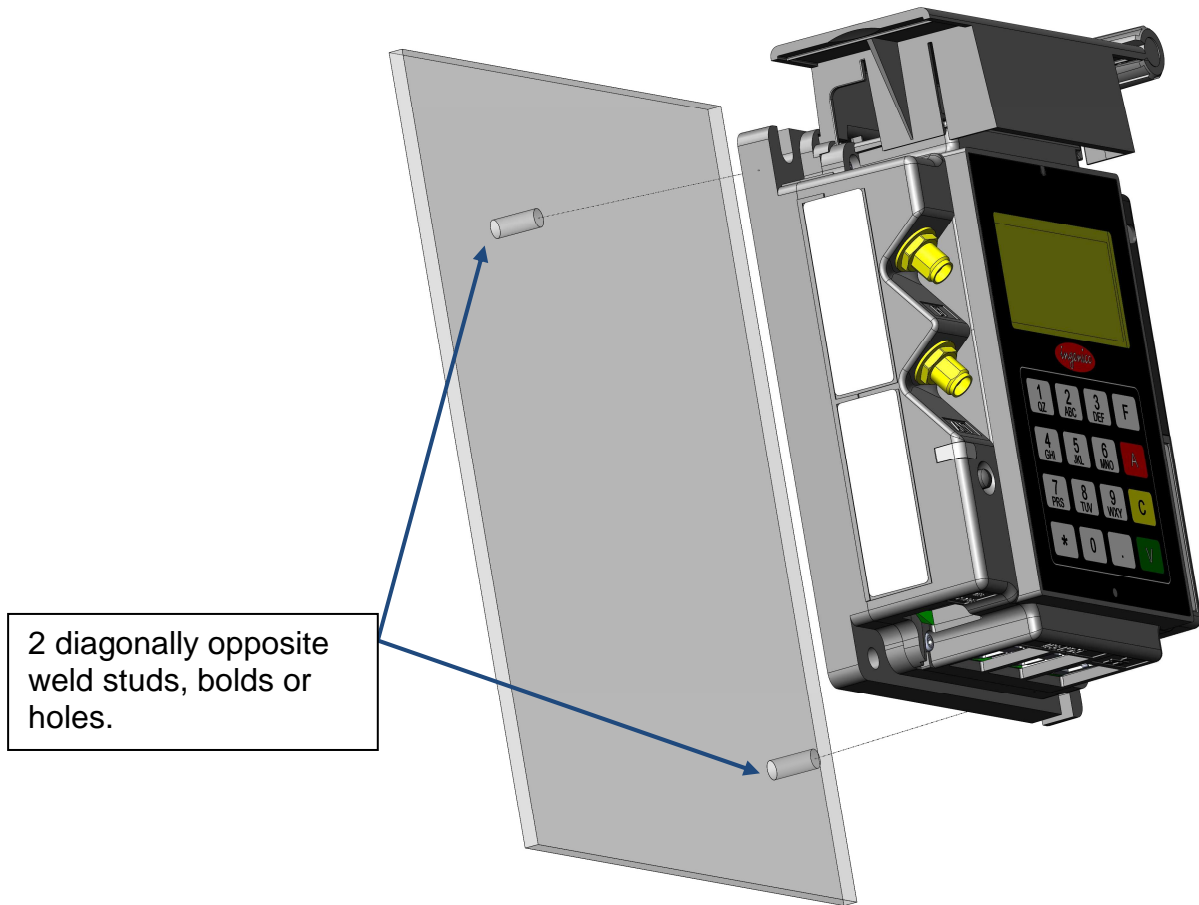

On the kiosk, 2 M4 studs Length 11-15 mm, bolts or holes must be done.

Detail of dimensions on the iUI120 for 2 diagonally opposite slots mounting.

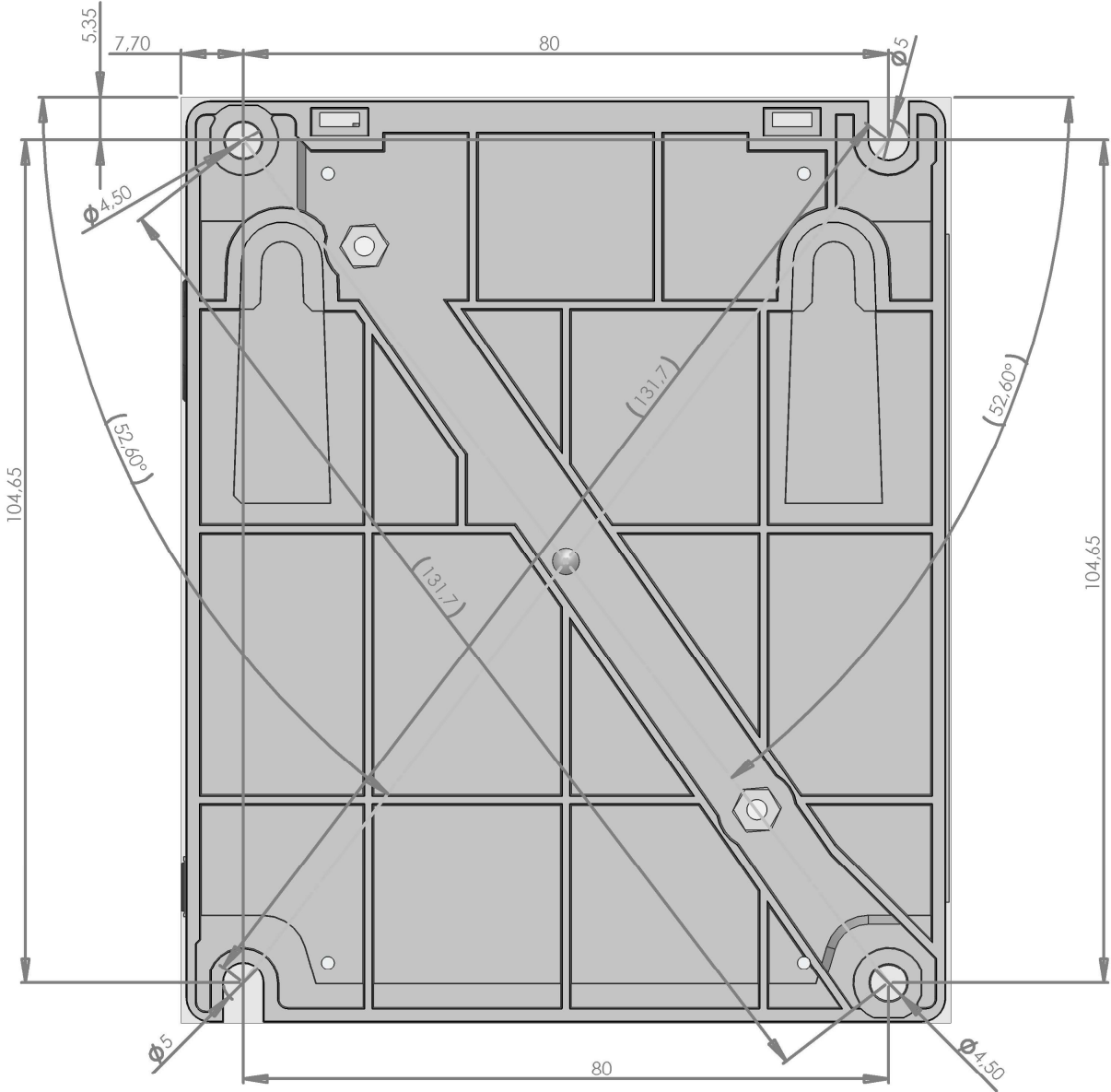

7 MAINTENANCE

7.1 CONFIGURATION

The iUI120 unit supplied to you has operational configuration loaded. In factory, software is loaded in the iUI120, as well as parameter definition files.

The parameter definition file of the UCMC component is used, in particular, to determine the type of printer used (local/host) and the position of the host (COMx). To change configuration, you must load a new parameter definition file (supplied by Ingenico).

This operation can be performed using the LLT or a USB key (see § Loading by USB key)

For more information concerning configuration, contact Ingenico Technical Support.

7.2 OPERATING LIFE

Minimum operating life of 5 years.

8 CLEANING INSTRUCTIONS

The external front face should be carefully cleaned on a regular basis.

The goal is to keep the display and the keyboard free of dirt and solvents.

First of all, unplug all the wires from the terminal during this operation.

Good rules for proper cleaning of the terminal are:

- Use a soft cloth that is very slightly soaked with soapy water to clean the outside of the terminal.
- The glass has special surface treatment but must be carefully clean.
- Do not clean the electrical connections.
- Do not use in any case, solvents, detergents or abrasive products: Those materials might damage the plastic or electrical contacts.
- Avoid also the use of pressurized liquids.
- Avoid exposing the terminal to the direct rays of the sun.

9 DISASSEMBLING THE PRODUCTS ACCORDING TO WEEE DIRECTIVE

9.1 IUC120 END-OF-LIFE DISASSEMBLY INSTRUCTIONS

This document is intended for treatment and recycling facilities. It provides the basic instructions for the disassembly of Ingenico products to remove components and materials requiring selective treatment, as defined by EU directive 2002/96/EC, Waste Electrical and Electronic Equipment (WEEE).

Ce document est destiné aux installations de traitement et de recyclage. Il fournit les instructions de base pour le démontage de produits Ingenico afin de retirer les composants et matériaux nécessitant un traitement sélectif, tel que défini par la directive européenne 2002/96/CE, sur les Déchets d'Equipements Electriques et Electroniques (DEEE).

9.1.1 MODELS AND DESCRIPTIONS

MODÈLES ET DESCRIPTIONS

Products covered by this disassembly instructions.

Produits concernés par ces instructions de démontage.

Product Name <i>Nom du produit</i>	Product description <i>Description du produit</i>	Product mass (g) <i>Masse du produit (g)</i>
IUI120	Unattended payment application module	247g

9.1.2 COMPONENTS AND MATERIALS REQUIRING SELECTIVE TREATMENT

COMPOSANTS ET MATERIAUX NÉCESSITANT UN TRAITEMENT SÉLECTIF

The following components and materials, if present in the Ingenico product(s), have to be removed and selectively treated.

Les composants et matériaux suivants, si présents dans le(s) produit(s) Ingenico, doivent être retirés et faire l'objet d'un traitement sélectif.

Components and materials <i>Composants et matériaux</i>	Quantity included in product(s) <i>Quantité contenue dans le(s) produit(s)</i>
Capacitors containing Polychlorinated biphenyls (PCB) <i>Condensateurs contenant du polychlorobiphényle (PCB)</i>	0
Components containing Mercury, such as switches or backlighting lamps <i>Composants contenant du mercure, tels que les interrupteurs ou les lampes à rétroéclairage</i>	0
Batteries <i>Piles et accumulateurs</i>	1
Printed circuit boards greater than 10 cm² <i>Cartes de circuits imprimés de plus de 10 cm²</i>	3max (2 + 1)
Toner cartridges <i>Cartouches de toner</i>	0
Plastic containing brominated flame retardants <i>Matières plastiques contenant des retardateurs de flamme bromés</i>	0
Asbestos waste and components which contain asbestos <i>Déchets d'amiante et composants contenant de l'amiante</i>	0
Cathode ray tubes <i>Tubes cathodiques</i>	0
Chlorofluorocarbons (CFC), Hydrochlorofluorocarbons (HCFC) or Hydrofluorocarbons (HFC), Hydrocarbons (HC) <i>Chlorofluorocarbones (CFC), hydrochlorofluorocarbone (HCFC) ou hydrofluorocarbone (HFC), hydrocarbures (HC)</i>	0
Gas discharge lamps <i>Lampes à décharge</i>	0
Liquid crystal displays (LCD) of a surface greater than 100 cm² and all those back-lighted with	0

gas discharge lamps <i>Écrans à cristaux liquides (LCD) d'une surface supérieure à 100 cm² et tous les écrans rétroéclairés par des lampes à décharge</i>	
External electric cables <i>Câbles électriques extérieurs</i>	0
Components containing refractory ceramic fibres <i>Composants contenant des fibres céramiques réfractaires</i>	0
Components containing radioactive substances <i>Composants contenant des substances radioactives</i>	0
Electrolyte capacitors measuring greater 2,5 cm in diameter or height <i>Condensateurs électrolytiques mesurant plus de 2,5 cm de diamètre ou de hauteur</i>	0

9.1.3 PRODUCT DISASSEMBLY PROCESS

PROCESSUS DE DEMONTAGE DU PRODUIT

Basic steps to remove components and materials previously identified and requiring selective treatment.

Etapas de base pour retirer les composants et matériaux précédemment identifiés et nécessitant un traitement sélectif.

Step <i>Etape</i>	Product disassembly process <i>Processus de démontage du produit</i>
1	Remove the 4 screws of front casing and of the rear cover <i>Oter les 4 vis du capot avant et du capot arrière</i>
2	Remove the cover, remove the FPC <i>Oter le capot, ôter le FPC.</i>
3	Remove the 4 screws on the extension card. Lift the card, disconnect the FPC below. Remove the extension card. <i>Oter les 4 vis sur la carte d'extension, Soulever la carte d'extension et déconnecter le FPC dessous. Oter la carte extension.</i>
4	Remove the battery from extension card <i>Oter la pile de la carte extension.</i>
5	Remove the 4 screws on the plastic spacer. Remove the plastic spacer, the rear metal plate, the plastic antenna holder <i>Oter les 4 vis maintenant l'entretoise plastique. Oter l'entretoise plastique, puis la tôle arrière, puis le support plastique de l'antenne</i>
6	Remove the keypad card and the displays. <i>Oter la carte clavier et les afficheurs</i>

10 STANDARDS

10.1 ELECTRICAL CONSUMPTIONS

- Max power supply :
 - iUI120 < 24W
Value measured for Power supply 12V at 25°C
- Average Power device waiting for host solicitation :
 - iUI120 < 1,44W
Value measured for Power supply 12V at 25°C
- Max Power device in stand-by mode :
 - iUI120 < 4,8 mW
Value measured for Power supply 12V at 25°C
- Back up battery life
 - 1 storage year + 7 years in field at 45 days/year storage rate (25°C)

10.2 TEMPERATURE AND HUMIDITY

- Operating & Storage conditions :
 - Relative humidity: 5% to 85% non-condensing.
 - External temperature range: -20 °C to 65 °C.

10.3 ENVIRONMENTAL SPECIFICATION CONTINUED

- Operating conditions :
 - Vibrations resistance:
 - NF EN 60068-2-6 and the below conditions (10 tests sequences per axis) :
 - From 5Hz to 9Hz with 3,3mm amplitude
 - From 9Hz to 200Hz with 10m/s² acceleration
 - From 200Hz to 500Hz with 15m/s² acceleration
 - Endurance 30 mn on each resonance frequency
 - Bumps resistance:
 - NF EN 60068-2-29. E
 - Each direction, 500 drops 1/2 sinus 25g - 6ms
- Degradation iUI120 specification:
 - Certified anti-tamper and attack resistant.

- Drop:
 - Drop 1m on concrete surface all faces

10.4 EC STANDARD COMPLIANCE MARKING

EC standard compliance marking certifies that the product stipulated below:
iUI120

Conforms to the following harmonized standards:

- IEC/EN 60950-1: Electrical safety of data processing equipment including electrical office equipment.
EN 60950-1:2006 + A11-2009 + A1-2010 + A12-2011
- EN 55022: Data processing equipment – Radiofrequency disturbance characteristics - Limits and measurement methods.
EN 55022 2006 + A1 (2007)
- EN 55024: Data processing equipment – Immunity characteristics - Limits and measurement methods.
EN 55024 :1998 + A1- 2001 + A2 – 2003

10.5 IC STATEMENTS

This class (B) digital apparatus complies with Canadian ICES-003. Under Industry Canada regulations, this radio transmitter may only operate using an antenna of a type and maximum (or lesser) gain approved for the transmitter by Industry Canada. To reduce potential radio interference to other users, the antenna type and its gain should be so chosen that the equivalent isotropically radiated power (e.i.r.p.) is not more than that necessary for successful communication."

Conformément à la réglementation d'Industrie Canada, le présent émetteur radio peut fonctionner avec une antenne d'un type et d'un gain maximal (ou inférieur) approuvé pour l'émetteur par Industrie Canada. Dans le but de réduire les risques de brouillage radioélectrique à l'intention des autres utilisateurs, il faut choisir le type d'antenne et son gain de sorte que la puissance isotrope rayonnée équivalente (p.i.r.e.) ne dépasse pas l'intensité nécessaire à l'établissement d'une communication satisfaisante.

"This device complies with Industry Canada licence-exempt RSS standard(s). Operation is subject to the following two conditions: (1) this device may not cause interference, and (2) this device must accept any interference, including interference that may cause undesired operation of the device."

Le présent appareil est conforme aux CNR d'Industrie Canada applicables aux appareils radio exempts de licence. L'exploitation est autorisée aux deux conditions suivantes : (1) l'appareil ne doit pas produire de brouillage, et (2) l'utilisateur de l'appareil doit accepter tout brouillage radioélectrique subi, même si le brouillage est susceptible d'en compromettre le fonctionnement.

This radio transmitter (2586D-IUI12XRFB) has been approved by Industry Canada to operate with the antenna types listed below with the maximum permissible gain and required antenna impedance for each antenna type indicated. Antenna types not included in this list, having a gain greater than the maximum gain indicated for that type, are strictly prohibited for use with this device.

Le présent émetteur radio (2586D-IUI12XRFB) a été approuvé par Industrie Canada pour fonctionner avec les types d'antenne énumérés ci-dessous et ayant un gain admissible maximal et l'impédance requise pour chaque type d'antenne. Les types d'antenne non inclus dans cette liste, ou dont le gain est supérieur au gain maximal indiqué, sont strictement interdits pour l'exploitation de l'émetteur.

10.6 FCC STATEMENT

FCC standard compliance marking certifies that the product stipulated below:
iUI120

- conforms to the following harmonized standards :
 - part 15 subpart B of the FCC rules

This class (B) digital apparatus complies with Canadian ICES-003.

Information to users:

Changes or modifications not expressly approved by the party responsible for compliance could void the user's authority to operate the equipment.

NOTE: This equipment has been tested and found to comply with the limits for a Class B digital device, pursuant to part 15 of the FCC Rules. These limits are designed to provide reasonable protection against harmful interference in a residential installation. This equipment generates uses and can radiate radio frequency energy and, if not installed and used in accordance with the instruction, may cause harmful interference to radio communications. However, there is no guarantee that interference will not occur in a particular installation. If this equipment does cause harmful interference to radio or television reception which can be determined by turning the equipment off and on, the user is encouraged to try to correct interference by one or more of the following measures:

- Reorient or relocate the receiving antenna.
- Increase the separation between the equipment and receiver.
- Connect the equipment into an outlet on circuit different from that to which the receiver is connected.
- Consult the dealer or an experienced radio/TV technician for help.

This device complies with FCC and IC radiation exposure limits set forth for general population. This device must be installed to provide a separation distance of at least 20cm from all persons and must not be co-located or operating in conjunction with any other antenna or transmitter.

10.7 ENVIRONMENT (WEEE, BATTERIES AND PACKAGING)

This product is labelled in accordance with European Directives 2002/96/EC concerning Waste Electrical and Electronic Equipment (WEEE) and 2006/66/EC concerning Batteries and Accumulators. Those provisions are requiring producers and manufacturers to become liable for take-back, treatment and recycling upon end of life of equipment and batteries.



The associated symbol means that WEEE and waste batteries must not be thrown away but collected separately and recycled.

Ingenico ensures that efficient collection and recycling schemes are set-up for WEEE and batteries according to the local regulation of your country. Please contact your retailers for more detailed information about the compliance solution in place for disposing of your old product and used batteries.

Packaging waste must also be collected separately to assure a proper disposal and recycling.

Please note that proper recycling of the electrical and electronic equipment and waste batteries will ensure safety of human health and environment.

