



beyond  
payment

# User Guide

## iWL2xx Wireless Series



# Contents

---

<b>1. Introduction</b>	<b>4</b>
<b>2. Presentation</b>	<b>5</b>
2.1. Content of the box	5
2.1.1. Terminal	5
2.1.2. Base ( optional )	5
2.2. Overview of the iWL2XX	6
2.3. Keyboard details and functionality	7
<b>3. Use of the terminal</b>	<b>7</b>
3.1. Adjusting contrast (B&W display only)	7
3.2. Switching off the terminal	8
3.3. Reading cards	8
3.4. Installing the terminal on the base	9
<b>4. Installation</b>	<b>10</b>
4.1. Recommendations	10
4.2. Terminal connections	10
4.3. Installing Modules	11
4.3.1. SAM1/SAM2/SIM	11
4.3.2. MicroSD Memory Card	11
4.4. Paper roll	13
4.4.1. Mains characteristics of INGENICO paper roll	13
4.4.2. Installing paper roll	14
4.5. Battery	15
4.5.1. Main characteristics	15
4.5.2. Installing the battery	15
4.5.3. Charging the battery	16
4.5.4. Changing the battery	17
<b>5. Base</b>	<b>18</b>
5.1.1. Base rear connections	18

5.1.2. Base downside connections	19
5.1.3. Fasten your base on desk	20
<b>6. Recommendations</b>	<b>21</b>
6.1. Safety	21
6.2. Security of your terminal	22
6.3. Telephone call	22
<b>7. Standards</b>	<b>23</b>
<b>8. Troubleshooting</b>	<b>26</b>
<b>9. Annex</b>	<b>27</b>

# 1. Introduction

---

We hope that you will be fully satisfied with your new terminal iWL2XX. This terminal is available in different models. Please select by yourself in this documentation items related to your model.

Read this guide to understand and make the best use of your terminal. It presents you the necessary information about use, installation, maintenance, safety and security recommendations.



---

## WARRANTY / SECURITY

Use only the power supply included with the product to ensure best performance and safety. Maintenance should only be provided by Ingenico authorized technician. Failure to comply with these instructions will void the manufacturer's responsibility.

---



**This symbol indicates an important Warning.**

---



**This symbol indicates a piece of advice.**

---

## 2. Presentation

---

### 2.1. Content of the box

---

#### 2.1.1. Terminal

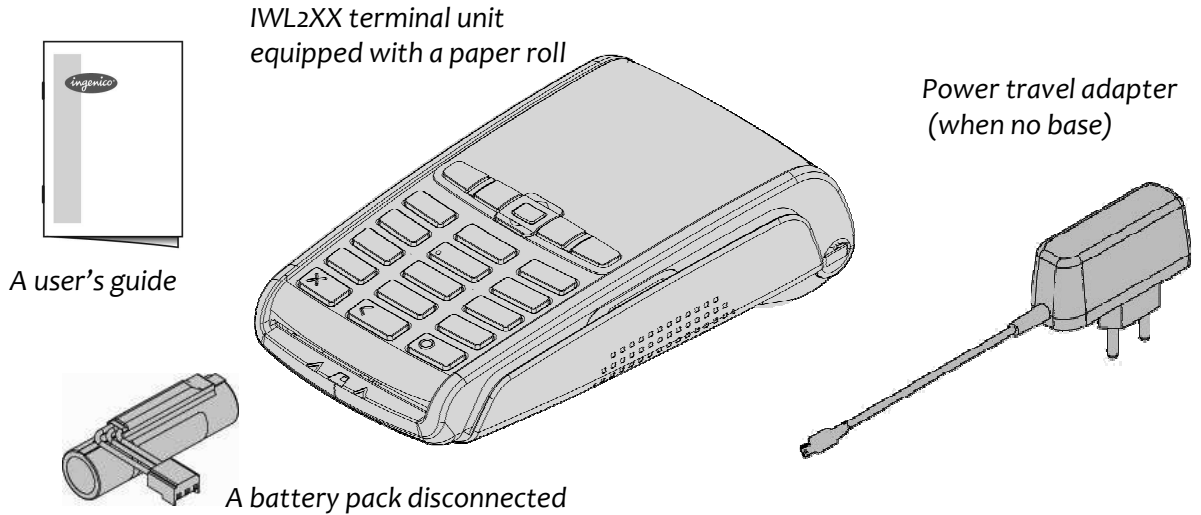

#### 2.1.2. Base ( optional )

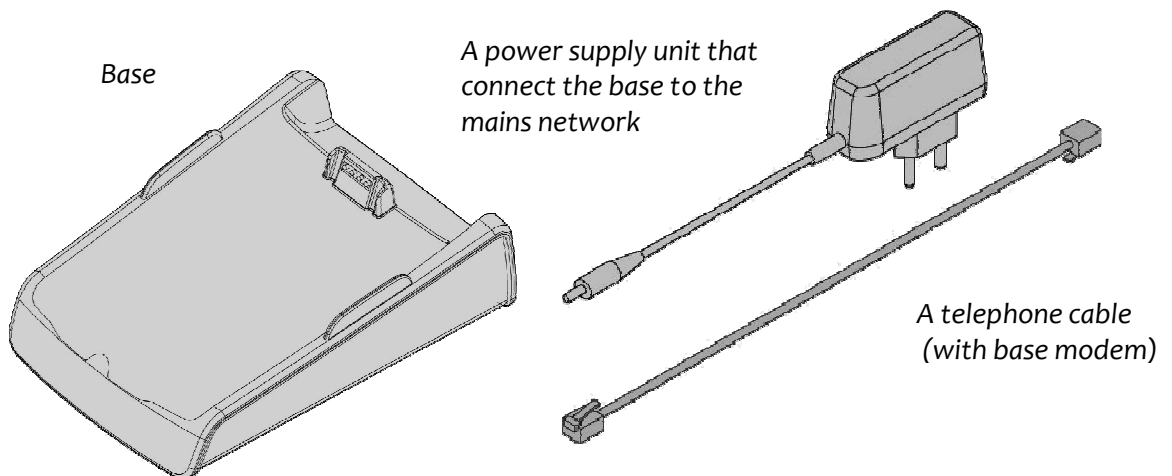

#### **WARNING**

The power supply unit provided with your equipment is specially designed for Ingenico terminals. Do not use any other power supply. The use of a power supply with apparently similar voltage/current characteristics may damage your terminal.

---



#### **ADVICE**

Keep the packaging. It must be re-used whenever the terminal is shipped.

---

## 2.2. Overview of the iWL2XX

### Terminal unit

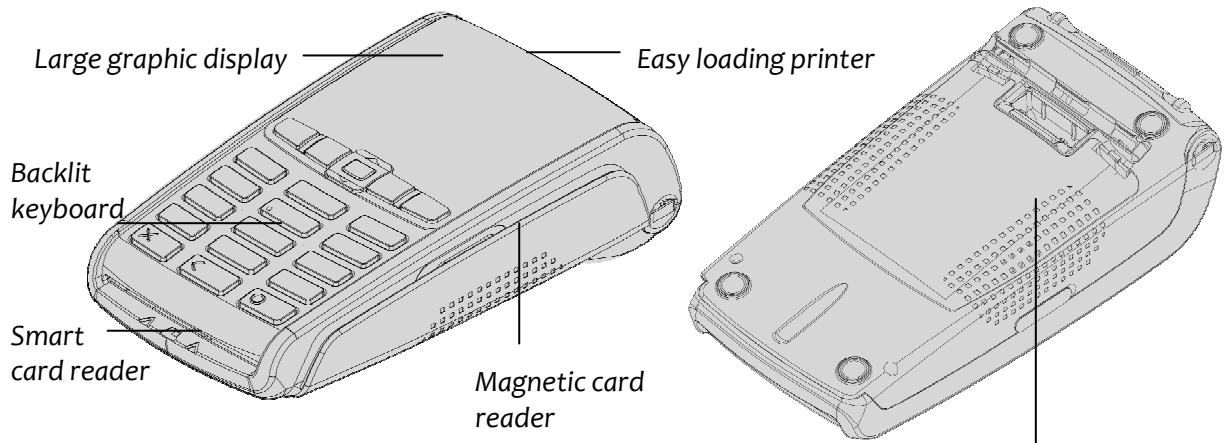

#### Compartment where are located :

- the battery pack
- the SAM1/SAM2/SIM connector
- the module microSD
- the 2<sup>nd</sup> Smart card reader

Weight (without paper roll nor battery)	290g for the R25 model and 310g for the R40 model
Dimensions (L x w x h)	150x76x44mm for the R25 model and 164,5x76x53,5mm for the R40 model
Mains network	100-240VAC / 50-60 Hz - Class II equipment
Connections on terminal	Micro USB AB serial link

### Base unit

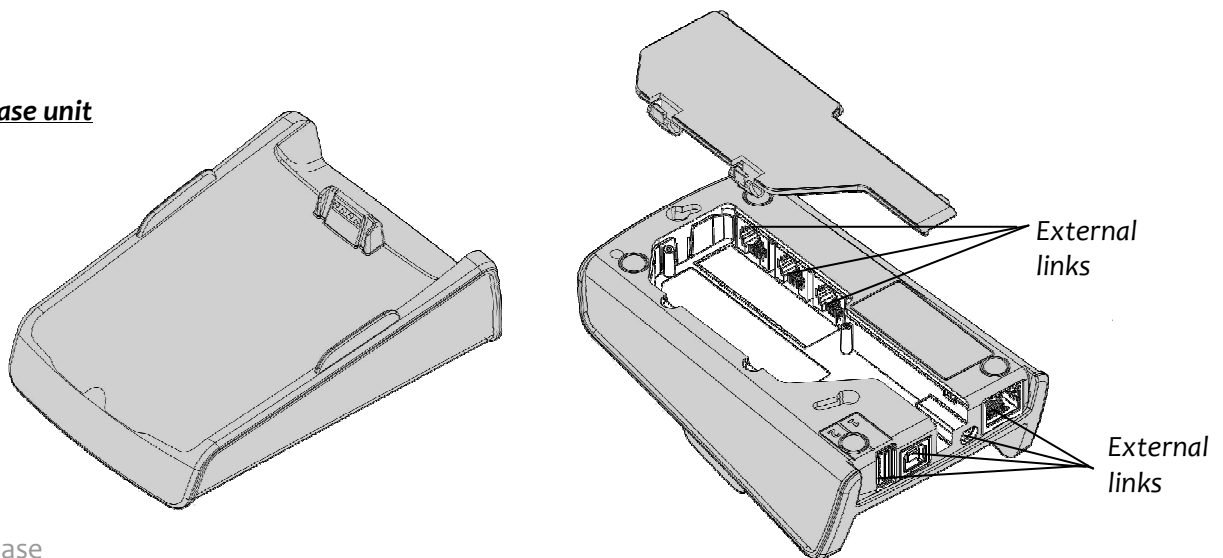

#### Base

Weight	About 150g
Dimensions (L x w x h)	140,7x87,7x45 mm

#### Power supply unit

Weight	About 100g
	2pole sockets 1A (traveller power supply) or 1 A (base power supply)

Power supply units are specially fitted for INGENICO terminals.

## 2.3. Keyboard details and functionality

Some keys can have other functions according to the applications that are in the terminal.

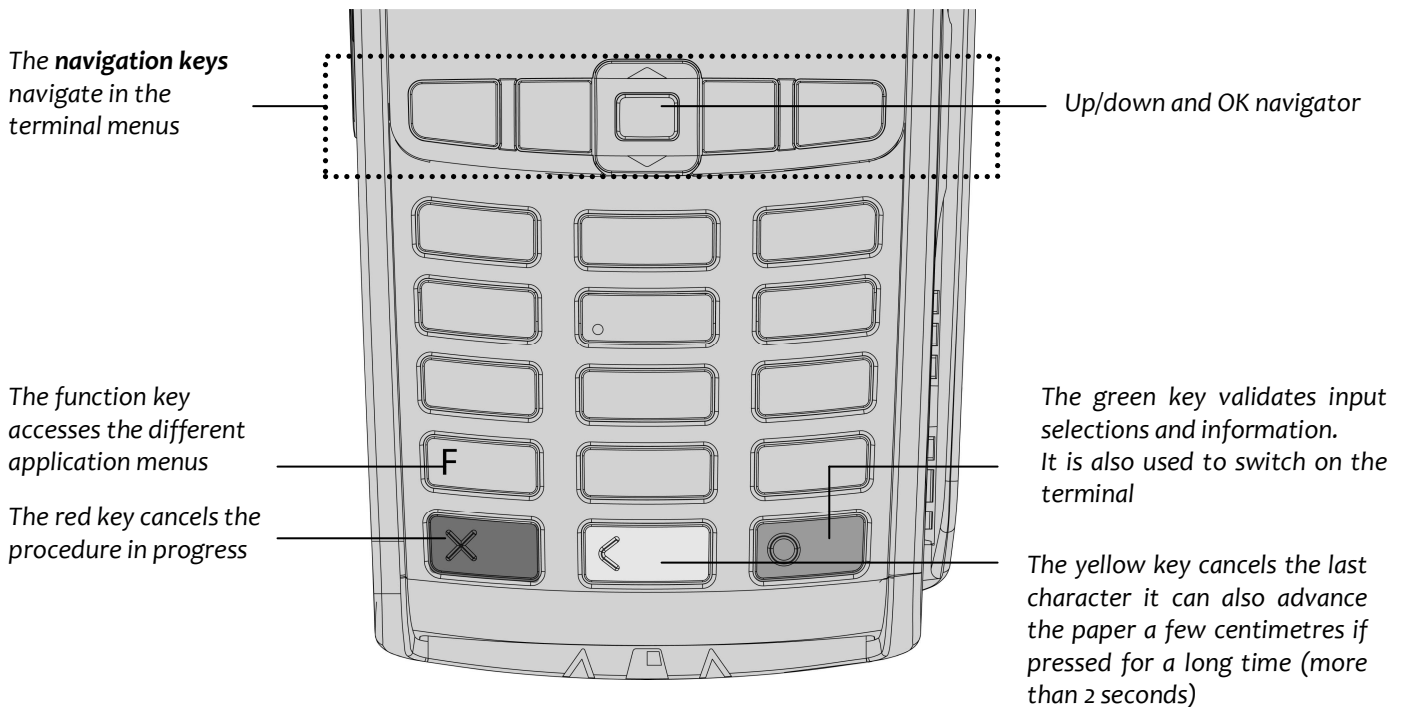

## 3. Use of the terminal



### ADVICE

Before using the terminal, always check if the roll of paper is present.

### 3.1. Adjusting contrast (B&W display only)

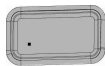
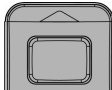
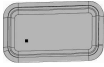
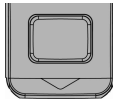

If you wish to increase or to decrease the contrast of the characters displayed on black and white display, press simultaneously  and navigator UP key  in order to increase the contrast, or  and navigator DOWN key  in order to decrease the contrast.

Keep pressing the keys as long as necessary.

### 3.2. Switching off the terminal

---

If the battery is empty and the terminal in use is removed from its base, the terminal automatically shuts off.

It may also be forced stopped by pressing simultaneously  and  (yellow key) for one second.

In order to restart the terminal, press  (green key) on the keyboard.

### 3.3. Reading cards

---

#### Magnetic stripe card

The card can be read either from bottom to top or from top to bottom, with the stripe facing the terminal. Use a regular movement in order to ensure a reliable card reading.

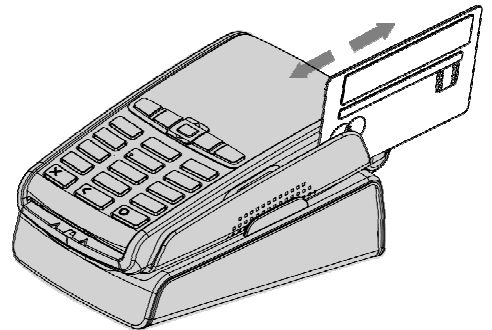

#### Smart card

- Card reader : insert the card horizontally with the metal chip facing upward and leave in position throughout the transaction.
- 2<sup>nd</sup> card reader (Optional) : is located under terminal trapdoor (on back of the terminal). Insert the card up side down, magnetic stripe visible.

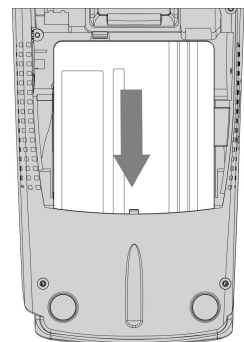
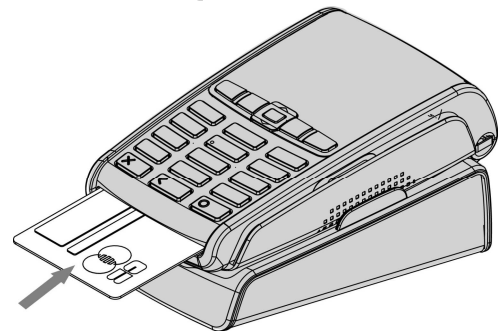

#### Warning

Switch off the terminal before opening the trapdoor.

---



### Contactless (optional)

- Bring the card firmly up to the active zone. Keep the card close to the reader during the transaction
- The 4 LEDs indicate transaction processing (as shown on the picture). On color screen terminal virtual LEDs are displayed.

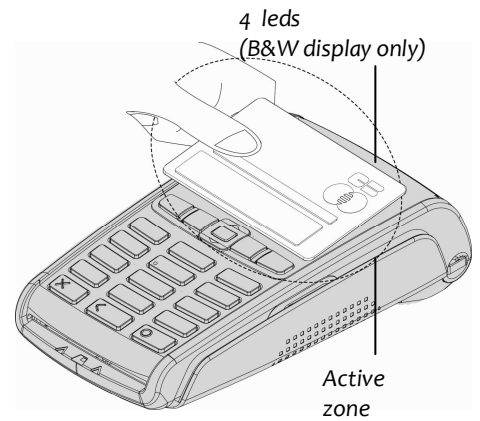

The terminal behavior for the cardholder may depend on:

- The terminal environment
- Local usage (language...)

## 3.4. Installing the terminal on the base

### Connecting the terminal on the base

Place the iWL2XX between the flanges on its base so that the contacts of the iWL2XX engage on the contacts provided on the base (see picture below).

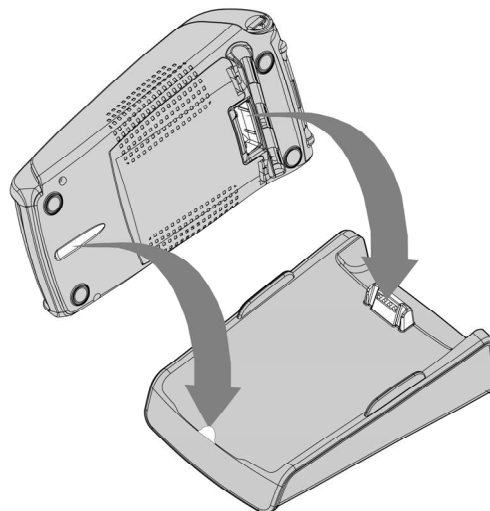

### Using the modem base (if modem fitted on your base)

Once installed, the base modem is designed to always be plugged into the mains network and be connected to a telephone line. The telephone line should not be shared.

The portable may be placed back on its base after each transaction. It **must** be placed on its modem base when telephone network is used for : authorization request, remote collection, downloading.

## 4. Installation

---

### 4.1. Recommendations

---

#### Location of the iWL2xx

Place the base on flat surface near an electric socket and, if modem option, a telephone socket. The terminal should be placed far from any very hot zones, protected from vibrations, dust, damp and electromagnetic radiation (computer screen, anti-theft barrier etc.).

The terminal must not be fixed to a counter in such a way that a user cannot pick up the terminal and use his/her body to conceal the PIN when it is requested.

#### Operating conditions

Ambiant temperature	from +5°C to +45°C
Max relative humidity	85% at +40°C

#### Storage conditions

Ambient temperature	from -20°C to +55°C
Max relative humidity	85% at +55°C

### 4.2. Terminal connections

---

- There is an USB connector (microAB) on the left side of the iWL2XX Wireless terminal (see below picture). This connector manages Host or Slave connexions.

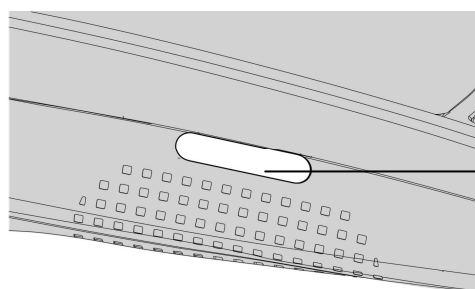

**USB (microAB)**  
Connector used for PC, travel charger adapter, USB Key, etc...)

*\*MicroAB connector durability: up to 10000 mating cycles*

- The terminal supports USB Keys with FAT16 or FAT32
- The USB Key has to be used with an USB adapter (refers to accessories section)

## 4.3. Installing Modules

### 4.3.1. SAM1/SAM2/SIM



#### CAUTION :

Switch off the terminal before opening the trapdoor.

The SAM/SIM connectors are located inside the terminal, in a closed compartment.

- Turn the terminal and unclip the trapdoor by pushing on the clips with your nails as shown with the arrows on the picture
- SAM1, SAM2 and SIM are identified by the engraved marks on the lower housing
- When introducing a SAM/SIM in its slot, be sure to put the cut corner as indicated on the picture
- Close the trapdoor.

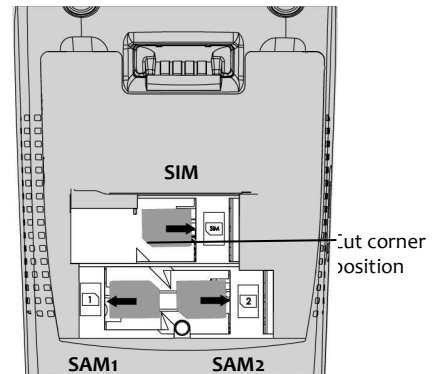
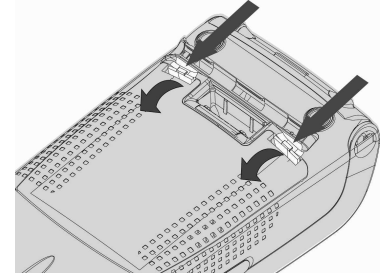

#### TIP

Use a piece of adhesive tape to grip the SAM for easier and faster removal.

### 4.3.2. MicroSD Memory Card



#### CAUTION :

Switch off the terminal before opening the trapdoor.

MicroSD connector is located inside the terminal, in a closed compartment.

#### To install a MicroSD Memory Card :

- Turn the terminal and unclip the trapdoor by pushing on the clips with your nails as shown with the arrows on the picture
- Remove battery pack (disconnecting is not necessary).
- Insert the MicroSD Memory Card into the connector slot as shown on the figure.  
Be sure to put the MicroSD contacts downside and the cut corner as indicated on the figure.

- Close the trapdoor

*The terminal supports MicroSD up to 32GB*

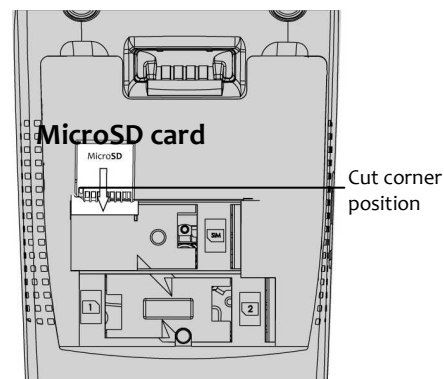
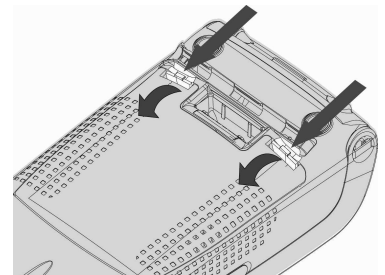

**To remove a MicroSD Memory Card :**

- Turn the terminal and unclip the trapdoor by pushing on the clips with your nails as shown with the arrows on the picture
- Remove battery pack (disconnecting is not necessary).
- Remove the MicroSD Memory Card. MicroSD connector has push/pull ability . Push on MicroSD card edge to remove it.
- Close the trapdoor

## 4.4. Paper roll

---

### 4.4.1. Mains characteristics of INGENICO paper roll

Depending on iWL model two paper roll can be used:

R40 paper roll Characteristics	Precisions
Colour	White
Width	58 mm
Diameter	40 mm
Length	About 18 metres

R25 paper roll Characteristics	Precisions
Colour	White
Width	58 mm
Diameter	25 mm
Length	About 9 metres

- The thermal paper can be deteriorated by poor storage conditions, so we recommend you to avoid :
  - storage in hot wet places (near air-conditioner, humidity higher than 85%)
  - exposure to sunlight or ultraviolet for long periods
  - contact with organic solvents (solvent type adhesive)
  - direct contact with materials containing plasticizers (PVC transparent folders or envelopes)
  - direct contact with «diaz» papers
  - direct contact with water
  - Rubbing or pressing the paper too strongly
- Recommended paper:  
AF50KS (Jujo), or F5041 (Mitsubishi), or TK50KS (Nippon\_Paper), or equivalent.



#### **WARNING**

For best product performance, **only use heat sensitized paper approved by Ingenico.**

---



#### **WARNING**

Switch off the terminal prior to installing a paper roll.

Use only paper approved by Ingenico.

The use of non approved paper is likely to damage the printer of your terminal.

---

#### 4.4.2. Installing paper roll

- Open the paper compartment by lifting the catch located at the rear of the iWL2XX and pull the cover to the rear of the terminal.

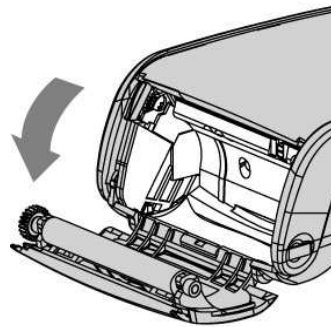
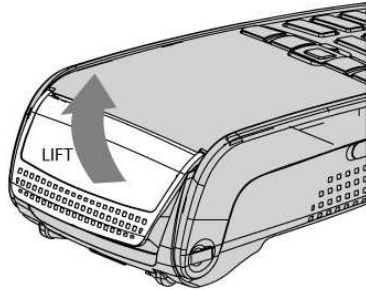

- Insert the paper roll in the compartment following the directions shown on the below picture
- Pull the paper up to the top of the terminal
- Maintain the paper and close the cover
- Press simultaneously on both upper corners of the paper flap, as shown by red arrows on picture, until it clips into position

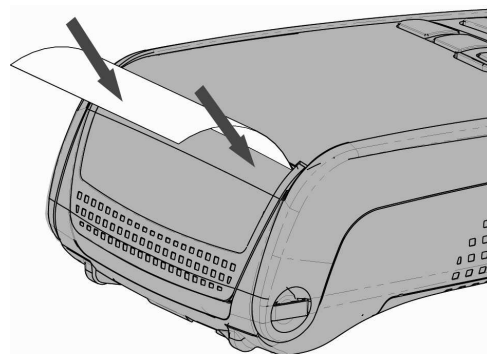
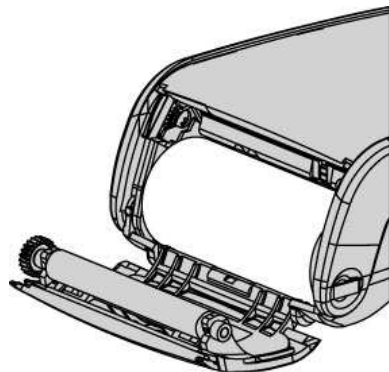

#### ADVICE

If you insert a new R40 paper roll, tear off the first length (one complete turn to avoid printing on adhesive tape footprint). This is not necessary on R25 paper roll as it has no tape.

## 4.5. Battery

### 4.5.1. Main characteristics

Characteristics	Li-ion
Capacity	2050mAh
Charge	50% capacity in 1.5h; full capacity in 4hours
Autonomy*	500 typical transactions up to 250h in stand by

\* depend on the terminal type and its base.

### 4.5.2. Installing the battery



#### **WARNING**

Switch off the terminal prior to connecting the battery.

- Turn your terminal and unclip the battery trapdoor by pushing on the clips with your nails as shown on the picture
- Disengage the trapdoor
- Take the battery pack included in the box
- Locate the battery pack connector beside the battery compartment
- Plug the battery pack connector **according to the connector locating system and the red wire** (as shown on picture). Verify that it locks.
- Place the battery pack in its compartment.
- Check that the wires' path is flat
- Close the battery compartment trapdoor.

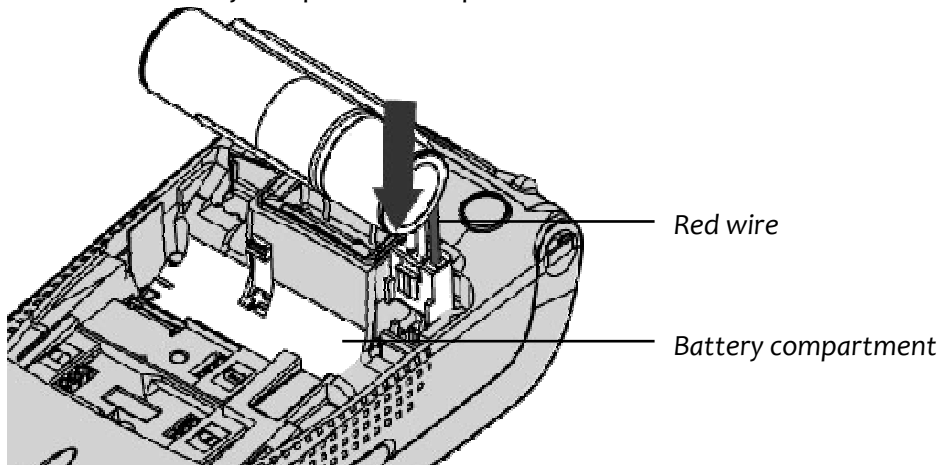
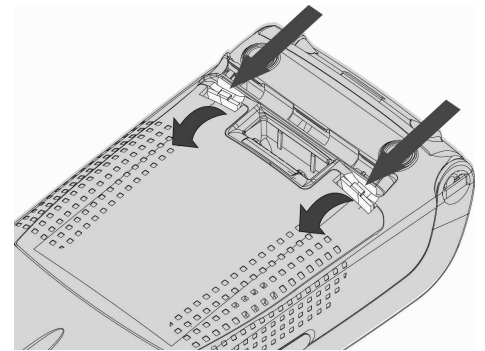

### 4.5.3. Charging the battery

➤ *When does the battery need to be charged?*

- On initial start up, charge the battery for 16 hours under the environmental conditions stated above
- When used daily, the terminal recharges its batteries each time it is placed on its base or each time the traveller charger is connected. Charging is automatic

➤ *How does the battery need to be charged?*

- The environment in which the charge takes place influences battery lifetime and autonomy (number of transactions)

The optimal conditions are as follows:

- Charging away from any external heat source (radiator, sun, enclosed area...)
- The optimal temperature is between +15°C and +25°C

➤ *How can the battery be charged?*

Using the base

- Place the terminal on its base
- **Check if the battery symbol is flashing or moving (=battery charging).**

Using the power travel adapter (the terminal is out of its base)

- Connect the traveller power supply unit to the terminal microAB connector located on the left side of the terminal.
- Connect the power supply unit to the power supply mains network
- **Check if the battery symbol is flashing or moving(=battery charging)**



#### 4.5.4. Changing the battery



**It is imperative to use a battery authorized by Ingenico.**

**There is danger of explosion if battery used is not approved by Ingenico.**

- Remove the terminal from its base

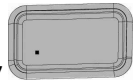
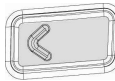

- Turn it off by pressing simultaneously  and  (yellow key) for about one second
- Remove the battery trapdoor (see section 4.5.2 “installing battery”)

- Lift the battery and remove it from its compartment

- Carefully disconnect battery, following the instructions below.

**a)** Unlock the connector by pressing the locking mechanism as indicated by F1 arrow while pulling wires (F2 arrow), to disconnect the connector. Release traction on it as soon as the connector comes unclipped

**b)** Finish extracting connector by tilting it slightly (F3 arrow) to bring it away from the terminal housing

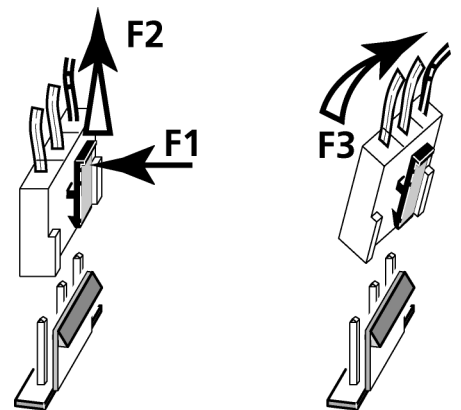

- Connect and install the new battery by following the instructions in section 4.5.2 “Installing battery”
- Close the battery trapdoor and charge the new battery. See section “o “Charging the Battery”
- In order to preserve the environnement, dispose used battery in compliance with current country recycling legislation.
- If the terminal is stored for a long time remove the battery from the terminal.

## 5. Base

---

IXL2xx Base is available in different models. Please select by yourself in this documentation items related to your model.



---

### WARNING

Turn off base power supply unit before connection operation.

---

#### 5.1.1. Base rear connections

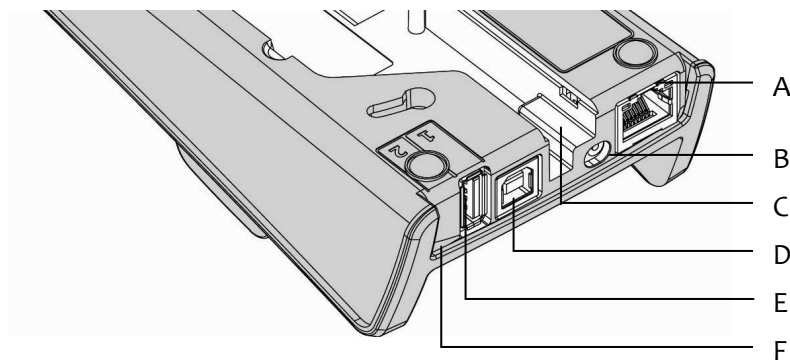

**A** = Ethernet socket (optional)

**B** = power supply unit socket

**C** = Path for wires.

**D** = USB Slave socket-CDC serial mode only (optional)

**E** = USB host Socket 1 (optional)

**F** = USB host Socket 2 (optional)



---

### WARNING

Select an electrical socket that complies with the general safety instruction given in section 6 “Recommendations” of this document.

---

Follow the below instructions :

- Connect the power supply unit after all other connections.
- Connect the power supply unit to the base socket **B**.
- Connect the power supply unit to the mains network .

### 5.1.2. Base downside connections

- Remove base trapdoor pushing on clips ( see clips location at red arrows)
- Connect all downside connections
- Use “path for wires” to manage cable exit
- Close trapdoor

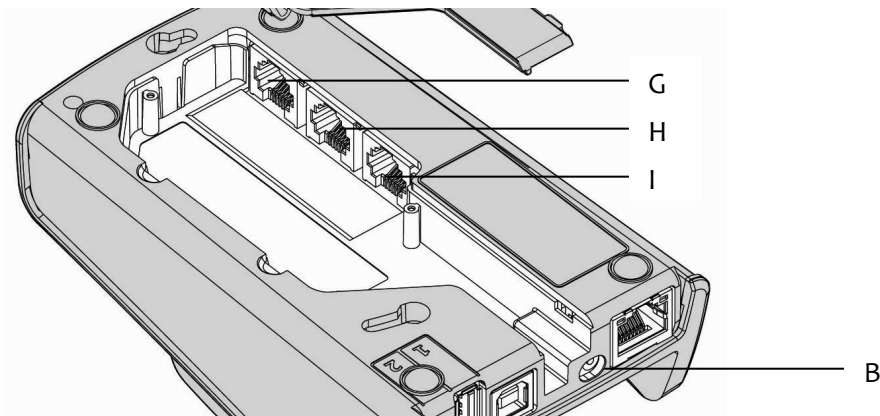
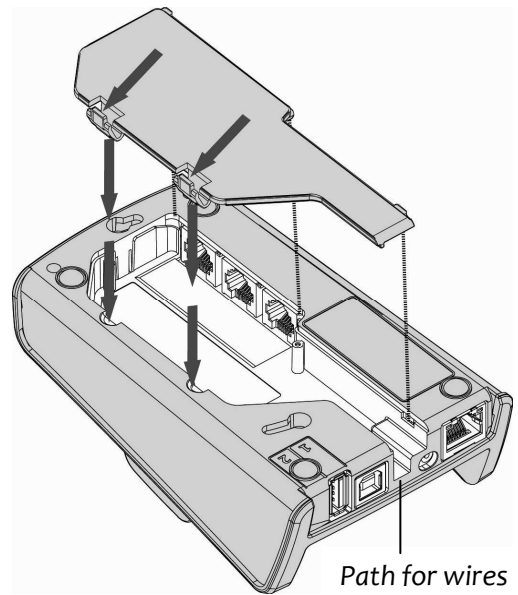

**G**= Serial link COM0 – RS232 (optional)

**H**= Serial link COM1 – RS232 (optional)

**I** = Modem socket (optional)

Follow the below instructions to connect the base to the telephone network :

- Disconnect power supply unit (socket **B**) in order to switch off the base prior to connecting it to the appropriate network.
- Connect telephone cable equipped if necessary with user country specific telephone plug, to the telephone network.
- Connect the other end of the wire to the base (socket **I**).
- Connect the mains power supply wire to the base (socket **B**).
- Connect base power supply block to the mains .

**Socket I** : TNV-3 circuit: Telecommunication Network Voltage, as per safety standard EN 60950-1.

### 5.1.3. Fasten your base on desk

It is possible to fasten base on desk thanks to buttonholes located on base bottom casing. Uses pattern beside to best locate screws position:



#### **WARNING**

Base must be set in horizontal position to insure terminal link work properly. This remains true when buttonholes are used. Uses wall docking station accessory to fasten base in non horizontal position.

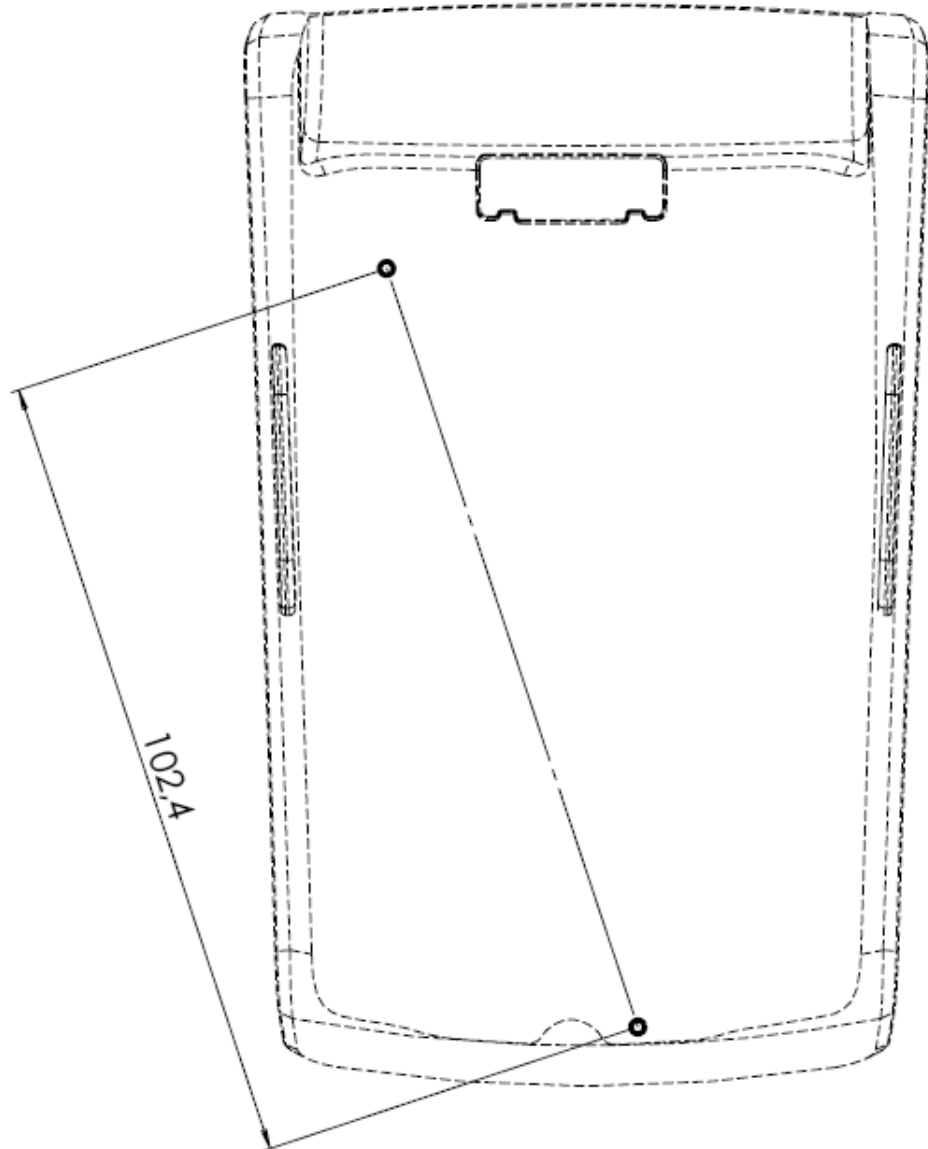

## 6. Recommendations

---

### 6.1. Safety

---

#### Powering down the iWL2XX base :

Disconnect the iWL2XX power supply block adapter from the electrical mains network.

#### Lithium cell (Backup battery)

The iWL2XX is fitted with an internal **lithium cell** which can only be accessed by a qualified technician.

#### Battery

iWL2XX is fitted with battery specially designed for this terminal.

- Only use the appropriate chargers and batteries listed in the Ingenico's catalogue.
- Do not short-circuit the battery.
- Do not attempt to remove the battery housing as its components cannot be modified.
- Do not disassemble
- Batteries in "end of life" must be disposed of at the appropriate sites.

The lifespan depends on:

- Features
- Cycle number of charge and discharge
- Use temperature



#### Warning

There is a risk of explosion if the battery is incorrectly replaced.  
Never place the battery next to a warmth source or in fire.

---

#### Electrical power outlet

The electrical outlet must meet the following criteria :

- Must be installed **near the equipment and easily accessible**;
- Must meet standards and regulations in the country where used;
- The protection of the installation must be set to 20 A.

#### Telephone network

The phone jack must comply with standards and regulations in the country where used.

### SAM1/SAM2/SIM readers compartment

The trapdoor for battery, SAM1/SAM2/SIM, readers located underneath the terminal, must be in place during the normal operation of the terminal. See sections "Removal of SAM1/SAM2/SIM, modules" as well as "Connecting the battery".

### On airplanes

Your handset must be switched off by removing the battery pack. Remove the battery from the terminal when on an airplane.

Non-compliance with these safety rules may result in legal action and/or a ban on later access to cellular network services.

### Explosion areas

Some regulations restrict the use of radio equipment in chemical plants, fuel depots and any site where blasting is carried out. You are urged to comply with these regulations. The terminal shall be protected by a specially fitted and certified cover enabling use in proximity to a fuel pump.

### Electronic health appliances

Your handset is a radio transmitter which may interfere with health appliances, such as hearing aids, pacemaker, hospital equipment, etc.

Your doctor or the equipment manufacturer will be able to provide you with appropriate advice.

## 6.2. Security of your terminal

---

Upon receipt of your terminal you should check for signs of tampering of the equipment. It is strongly advised that these checks are performed regularly after receipt. You should check, for example: that the keypad is firmly in place; that there is no evidence of unusual wires that have been connected to any ports on your terminal or associated equipment, the chip card reader, or any other part of your terminal. Such checks would provide warning of any unauthorised modifications to your terminal, and other suspicious behaviour of individuals that have access to your terminal. Your terminal detects any "tampered state". In this state the terminal will repeatedly flash the message "Alert Irruption!" and further use of the terminal will not be possible. If you observe the "Alert Irruption!" message, you should contact the terminal helpdesk immediately.

You are strongly advised to ensure that privileged access to your terminal is only granted to staff that have been independently verified as being trustworthy.

### **CAUTION**

NEVER ask the customer to divulge their PIN Code. Customers should be advised to ensure that they are not being overlooked when entering their PIN Code.

The terminal must never be put in or left at a location where it could be stolen or replaced with another device.

## 6.3. Telephone call

---

You have an urgent call to make while the iWL2XX is occupying the line.

In order to get a dial tone in short time:

Place the handset in the hang up position **pressing the red key (=cancel)**

**or disconnect the base power supply from the mains network**

**or disconnect the iWL2XX telephone connector from the telephone call socket, and place the telephone connector into the telephone wall socket.**

You hear a dial tone within 6 seconds.

## 7. Standards

### CE Marking

The CE marking indicates iWL2xx complies with the requirements of European Directive 1999/5/EC of 9 March 1999 on Radio and Telecommunications Terminal Equipment for:

- the protection of the health and the safety of the user and any other person.
- the protection requirements with respect to electromagnetic compatibility.

and complies with harmonised standards.

Depending iWL2xx model involved standards are:

EN 60950-1 :2006	According to 2006/95/EC	(Low Voltage Directive)
EN 55022 :2006	According to 2004/108/EC	(EMC Directive)
EN 55024 A2 :2003	According to 2004/108/EC	(EMC Directive)
EN 301489-1/7 /08-2005	According to 89/336/EEC	(EMC Directive)
EN 301 511 /12-2003	According to 1999/5/EC	(R&TTE Directive)
EN 62311 (2008) /07-2001	According to 1999/519/EEC	(R&TTE Directive)
EN 301489-1/17 /08-2008	According to 89/336/EEC	(EMC Directive)
EN 300 328 v1.4.2 /12-2000	According to 1999/5/EC	(R&TTE Directive)
EN 301489-3 /08-2002	According to 89/336/EEC	(EMC Directive)
EN 301357-1/2 (2008)	According to 1999/5/EC	(R&TTE Directive)
EN 50357;EN50364 /2001	According to 1999/519/EEC	(R&TTE Directive)
<b>European approval specification on connecting terminals with DTMF dialling to the public switched telephone network (Council Decision 1998/482/EC, Council Decision 1999/303/EC):</b>		
TS 103021-1/2/3	/09-2003	ES 203021 /1/2/3 (2006)
TR 103000-1/2/3/4	/06-2003	
ES 201187	/03-1999	

## FCC/IC Compliance (IWL2xx Bluetooth)

The FCC ID for IWL bluetooth Terminal model is: XKB-IWL2XXBPOS and IC number is: 2586D-IWL2XXBPOS

The FCC ID for IWL bluetooth Base model is: XKB-IWL2XXBBASE and IC number is: 2586D-IWL2XXBBASE



- This device complies with Part 15 of the FCC Rules. Operation is subject to the following two conditions:
  - (1) This device may not cause harmful interference, and
  - (2) This device must accept any interference received, including interference that may cause undesired operation.



- This device complies with Industry Canada licence-exempt RSS standard(s). Operation is subject to the following two conditions:
  - (1) This device may not cause harmful interference, and
  - (2) This device must accept any interference received, including interference that may cause undesired operation.
- Le présent appareil est conforme aux CNR d'Industrie Canada applicables aux appareils radio exempts de licence. L'exploitation est autorisée aux deux conditions suivantes :
  - (1) L'appareil ne doit pas produire de brouillage, et
  - (2) L'utilisateur de l'appareil doit accepter tout brouillage radioélectrique subi, même si le brouillage est susceptible d'en compromettre le fonctionnement.
- This class (B) digital apparatus complies with Canadian ICES-003.



- No changes shall be made to the equipment without the permission of Ingenico as this may void the user's authority to operate the equipment.



## End of life

The product belongs to the family of electrical and electronic equipment. Therefore, it is subjected to the WEEE directive which requires the collection and the recycling at the end of life product.

The Ingenico products present the symbol for the marking of electrical and electronic equipment as required by the WEEE Directive.



The crossed-out wheeled bin printed on the product gives the information about the requirement not to dispose of WEEE as unsorted municipal waste and to collect such WEEE separately.

To assure that the product is collected and recycled with respect to the environment, you must contact your supplier (in defect, contact the Ingenico local office or the commercial head office in charge of your country on [www.ingenico.com](http://www.ingenico.com), « contact us » page).

The abandonment or uncontrolled disposal of waste can cause harm to environment and to human health. So, by recycling your product in a responsible manner, you contribute to the preservation of natural resources and to the protection of human health.

### BATTERIES

If your product contains batteries, they must be disposed of at the appropriate collection points.

## 8. Troubleshooting

---

The terminal does not turn on

- Check the battery ( is it discharged ?, is it connected ?)  
*A full discharged battery can take long charging time to recover*
- Connect terminal to traveler power supply or put it on powered base

The terminal does not connect to the telephone line

- Check the base power supply and telephone line cables
- Check for base electrical power network
- Check for Power On Ethernet network (POE powered base only: optional)

The terminal fails to establish a telephone connection

- Check that the tone of the phone line is free
- Check the configuration of the phone line and number to call
- Get technical support

Cards are not read

- Check if the magnetic card is swiped correctly (with magnetic stripe on terminal side).
- Swipe again the card with the magnetic stripe movement constant and rapid
- Check if the magnetic strip is not damaged, grooved or cracked
- Make sure you have inserted correctly the smart card into the smart card reader and removed the card only after the transaction is performed.







The ticket is not printed

- Check the presence and proper positioning of the paper roll.  
Possibly adjust the paper roll following the instructions in this manual (section 4.4 “Installing the paper roll”)
- Check the type of paper used (thermal paper must be used)
- Verify thermal paper sensitive side.

## 9. Annex

---

### Accessories list

- 192013244 : Car charger 5V 0.75A  $\mu$ USB iWL 
- 296110863: Power travel adapter JACK/ $\mu$ USB 
- 192010793 : CE traveler power supply unit ( $\mu$ USB)  
192010813 : UK traveler power supply unit ( $\mu$ USB)  
192010834 : US traveler power supply unit ( $\mu$ USB)  
192010855 : CHN traveler power supply unit ( $\mu$ USB)  
192010876 : AUS traveler power supply unit ( $\mu$ USB) 
- 192010579: CE base power supply unit (Jack)  
192010582 : UK base power supply unit (Jack)  
192010602 : US base power supply unit (Jack)  
192010623 : CHN base power supply unit (Jack)  
192010644 : AUS base power supply unit (Jack) 
- 192011323 : Pack BA Multi EU/US/UK 5V 1A (Jack) 
- 192011344 : Pack BA Multi EU/US/UK 5V 1A ( $\mu$ USB) 

#### **Comments:**

Using Power supply with Jack connector to charge the battery with the base.

Using Power supply with  $\mu$ USB connector to charge the battery without the base (direct connection to the  $\mu$ USB connector of the terminal).

- 296109815: USB Cord (microB on terminal side USBA male on the other side) 1.5 m black



- 296109807: USB Cord (microB on terminal side USBA female on the other side) 0,15 m black



- 295006044 : Battery pack Li-Ion standard

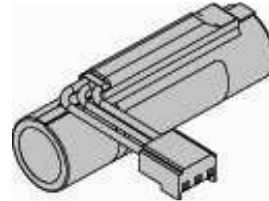

“This Document is Copyright © 2011 by INGENICO Group. INGENICO retains full copyright ownership, rights and protection in all material contained in this document. The recipient can receive this document on the condition that he will keep the document confidential and will not use its contents in any form or by any means, except as agreed beforehand, without the prior written permission of INGENICO. Moreover, nobody is authorized to place this document at the disposal of any third party without the prior written permission of INGENICO. If such permission is granted, it will be subject to the condition that the recipient ensures that any other recipient of this document, or information contained therein, is held responsible to INGENICO for the confidentiality of that information.

Care has been taken to ensure that the content of this document is as accurate as possible. INGENICO however declines any responsibility for inaccurate, incomplete or outdated information. The contents of this document may change from time to time without prior notice, and do not create, specify, modify or replace any new or prior contractual obligations agreed upon in writing between INGENICO and the user.

INGENICO is not responsible for any use of this device, which would be non consistent with the present document.

All trademarks used in this document remain the property of their rightful owners.”

Your contact

Ingenico  
192 avenue Charles de Gaulle  
92200 Neuilly sur Seine - France  
Tél: + 33 1 46 25 82 00 - Fax: + 33 1 47 72 56 95  
[www.ingenico.com](http://www.ingenico.com)

\*2961159