



# Access Point Deployment Guide

**On-Ramp Wireless Confidential and Proprietary.** This document is not to be used, disclosed, or distributed to anyone without express written consent from On-Ramp Wireless, Inc. The recipient of this document shall respect the security of this document and maintain the confidentiality of the information it contains. The master copy of this document is stored in electronic format, therefore any hard or soft copy used for distribution purposes must be considered as uncontrolled. Reference should be made to On-Ramp Wireless, Inc. to obtain the latest revision.

On-Ramp Wireless, Inc.  
10920 Via Frontera, Suite 200  
San Diego, CA 92127  
U.S.A.

Copyright © 2016 On-Ramp Wireless, Inc.  
All Rights Reserved.

The information disclosed in this document is proprietary to On-Ramp Wireless, Inc. and is not to be used or disclosed to unauthorized persons without the written consent of On-Ramp Wireless, Inc. The recipient of this document shall respect the security of this document and maintain the confidentiality of the information it contains. The master copy of this document is stored in electronic format, therefore any hard or soft copy used for distribution purposes must be considered as uncontrolled. Reference should be made to On-Ramp Wireless, Inc. to obtain the latest version. By accepting this material the recipient agrees that this material and the information contained therein is to be held in confidence and in trust and will not be used, copied, reproduced in whole or in part, nor its contents revealed in any manner to others without the express written permission of On-Ramp Wireless, Inc.

On-Ramp Wireless, Inc. reserves the right to make changes to the product(s) or information contained herein without notice. No liability is assumed for any damages arising directly or indirectly by their use or application. The information provided in this document is provided on an "as is" basis.

This document contains On-Ramp Wireless, Inc. proprietary information and must be shredded when discarded.

This documentation and the software described in it are copyrighted with all rights reserved. This documentation and the software may not be copied, except as otherwise provided in your software license or as expressly permitted in writing by On-Ramp Wireless, Inc.

Any sample code herein is provided for your convenience and has not been tested or designed to work on any particular system configuration. It is provided "AS IS" and your use of this sample code, whether as provided or with any modification, is at your own risk. On-Ramp Wireless, Inc. undertakes no liability or responsibility with respect to the sample code, and disclaims all warranties, express and implied, including without limitation warranties on merchantability, fitness for a specified purpose, and infringement. On-Ramp Wireless, Inc. reserves all rights in the sample code, and permits use of this sample code only for educational and reference purposes.

This technology and technical data may be subject to U.S. and international export, re-export or transfer ("export") laws. Diversion contrary to U.S. and international law is strictly prohibited.

RPMA<sup>®</sup> (Random Phase Multiple Access) is a registered trademark of On-Ramp Wireless, Inc.

Other product and brand names may be trademarks or registered trademarks of their respective owners.

Access Point Product Specification

010-0021-00 Rev. G

January 21, 2016

# Contents

---

- 1 Introduction .....1**
  - 1.1 Overview ..... 1
  - 1.2 Referenced Documents..... 3
  
- 2 Network Planning and Configuration Considerations ..... 4**
  - 2.1 Network Planning ..... 4
  - 2.2 Network Configuration ..... 4
  - 2.3 Backhaul ..... 5
  
- 3 Installation Prerequisites and Considerations ..... 6**
  - 3.1 Installation Prerequisites ..... 6
    - 3.1.1 Site Survey ..... 6
    - 3.1.2 AP Installation Configuration ..... 6
  - 3.2 Installation Considerations..... 7
    - 3.2.1 AP Antenna..... 7
    - 3.2.2 AP Antenna Cable..... 7
    - 3.2.3 GPS Antenna ..... 8
    - 3.2.4 Antenna Cable Lightning Suppression and Grounding..... 9
    - 3.2.5 AP DC Power Requirement ..... 9
    - 3.2.6 PoE Injector ..... 9
    - 3.2.7 Ethernet Cable ..... 10
    - 3.2.8 Solar Power ..... 11
    - 3.2.9 Outdoor Installation Hardware ..... 11
  
- 4 Regulatory Warnings ..... 12**
  - 4.1 Certifications ..... 12
  - 4.2 Transmit Power Restrictions..... 12
  - 4.3 FCC Warnings – United States ..... 12
  - 4.4 IC Warnings - Canada..... 13
  - 4.5 RF Exposure Statement ..... 14
  
- 5 AP Installation..... 15**
  - 5.1 AP and Ancillary Equipment..... 15
  - 5.2 AP Certified Configurations ..... 15
  - 5.3 AP Installation Configurations..... 18
  - 5.4 Base Station Configurations ..... 18
  - 5.5 General Grounding Guidelines ..... 18
    - 5.5.1 Grounding the AP and Antenna Cable Surge Suppressor ..... 20

5.5.2 Grounding the AP and GPS Antennas .....	21
5.6 AP Mounting Details .....	22
5.7 AP Pipe Mount Option .....	22
<b>6 Hardware Installation Verification .....</b>	<b>23</b>
6.1 Power Verification .....	23
6.2 AP Antenna and GPS Cable DVM Test .....	23
6.3 Antenna System Sweep Testing .....	23
6.4 Grounding .....	24
6.5 Connector Weather Sealing .....	24
6.6 Mounting Hardware .....	24
<b>7 AP Software Configuration via Web Interface .....</b>	<b>25</b>
7.1 Initial AP Network Configuration Prior to Installation .....	25
7.1.1 Initial AP Network Configuration for 3G Wireless Backhaul Modem .....	25
7.1.2 Initial AP Network Configuration for Customer Backhaul Modem .....	25
7.2 Login .....	26
7.3 Home Page .....	28
7.3.1 Dashboard Submenu .....	28
7.3.2 About Submenu .....	29
7.4 Access Point Menu .....	29
7.4.1 TRN Config Submenu .....	30
7.4.2 Field Config Submenu .....	32
7.4.3 Backhaul Config Submenu .....	34
7.4.4 Site Survey Submenu .....	36
7.5 Statistics Menu .....	36
7.5.1 Throughput Submenu .....	36
7.5.2 Counters Submenu .....	37
7.6 Admin Menu .....	37
7.6.1 Security Submenu .....	38
7.6.2 Network Submenu .....	41
7.6.3 Logs Submenu .....	43

---

8 AP Communication Troubleshooting.....	44
9 Troubleshooting Guidelines.....	45
10 Preventive Maintenance .....	46
Appendix A Site Survey Worksheet.....	47
Appendix B AP Installation Configuration Worksheet.....	48
Appendix C Basic AP Specifications.....	50
Appendix D Base Station Configuration .....	51
Appendix E Abbreviations and Terms.....	liii

DRAFT

## Figures

Figure 1. Ingenu Access Point .....	1
Figure 2. High Level Diagram for Indoor Site Installation of AP and Equipment .....	2
Figure 3. High Level Diagram for Outdoor Site Installation of AP and Equipment.....	3
Figure 4. PCTEL GPS Model GPSL1-TMG-SPI-40NCB .....	8
Figure 5. Block Diagram Showing PoE Injector Connections.....	10
Figure 2. AP Radio Block Diagram for FCC/IC .....	16
Figure 3: Sectorized AP Block Diagram for FCC Only.....	16
Figure 4: Dual Latency Block Diagram for FCC/IC .....	17
Figure 5. AP Radio Block Diagram for ETSI/Japan (no Cavity Filter).....	17
Figure 6. High Level Grounding Diagram.....	19
Figure 7. Grounding the AP.....	20
Figure 8. Grounding the GPS and AP Antennas .....	21
Figure 9. AP with Mounting Tabs Installed .....	22
Figure 10. Return Loss .....	24
Figure 11. Distance to Fault .....	24
Figure 12. Username and Password Prompt.....	26
Figure 13. Sample Method for On-site Debugging of an AP Installation .....	44

## Tables

Table 1. Software Versions .....	1
Table 2. Attenuation at 2.4 GHz for Common Types of Antenna Cables.....	8
Table 3. Surge Protector Mount Locations .....	9
Table 4. Tested Ethernet Cable and Connector Combinations.....	10
Table 5: AP installation configurations & domains.....	12
Table 6. Fields on the Access Point Screen .....	29
Table 7. Fields on the Total Reach Network Configuration Screen.....	30
Table 8. Parameters on the Field Configuration Screen.....	33

---

Table 9. Fields on the Backhaul Configuration Screen .....	35
Table 10. Parameters on the Security Configuration Screen.....	39
Table 11. Fields on the Network Configuration Screen .....	41
Table 12. Troubleshooting Guide.....	45
Table 13. Preventive Maintenance Schedule.....	46
Table 14. Ingenu TRN Base Station Configuration Options.....	51

DRAFT

# Revision History

---

Revision	Release Date	Change Description
A	August 2, 2013	Initial release.

DRAFT



# 1 Introduction

---

This document provides network planning, installation, configuration and preventive maintenance information for the Access Point model as a part of the Ingenu Total Reach Network (TRN). There are multiple configurations for the Access Point (AP) depending upon the country in which it will be used. For details, refer to the *Access Point Product Specification (014-0030-00)*.



Figure 1. Ingenu Access Point

This document is compatible with the software versions shown in the following table.

Table 1. Software Versions

Software	Version
System Release	2.1
AP	6.6.0

## 1.1 Overview

The AP is the core component of the Ingenu Total Reach Network (TRN) and TRN base station solutions. It provides the functionality of an RF transceiver, a data processor, and a data router. The RF transceiver operates in the unlicensed 2.4 GHz ISM band on one of thirty eight 1 MHz channels. The AP utilizes Time Division Duplexing and Direct Sequence Spread Spectrum with Ingenu's proprietary Random Phase Multiple Access (RPMA) modulation technique. The maximum transmit power of the AP's transceiver (at the antenna connector) is +30 dBm (1 Watt). GPS is used for timing and synchronization.

All endpoint devices designed with On-Ramp Total Reach Network technology communicate directly with TRN base stations installed on existing communication towers, rooftops, streetlights, substations, and other elevated sites to collect data or control the endpoint devices. Base station networks are designed and deployed to meet coverage, capacity, and redundancy objectives.

Ingenu APs are weatherproof with an IP 66 rating and can be installed indoors or outdoors. Ingenu offers various base station configurations to support a wide variety of installations. Section 5.4 defines these pre-configured base station packages. This document focuses on the installation, configuration, and maintenance of the Access Point. For base station-specific information, see the installation manuals for each of the base stations.

An AP installation requires:

- A 10/100 IP-over-Ethernet connection with 128 Kbps minimum throughput for backhaul to the Ingenu gateway
- A Power-over-Ethernet (PoE) injector that combines power and data over the same Ethernet cable. The AP requires a passive PoE injector and cannot be powered directly from most switches

**NOTE:** The AP is not 802.3AF or 802.3AT compliant.

- An AC or DC power source capable of supplying 48 VDC at a minimum of 25 Watts to the PoE injector. For very long PoE cables, a 56 VDC power supply is recommended.
- A GPS antenna and cable
- An AP antenna and cable

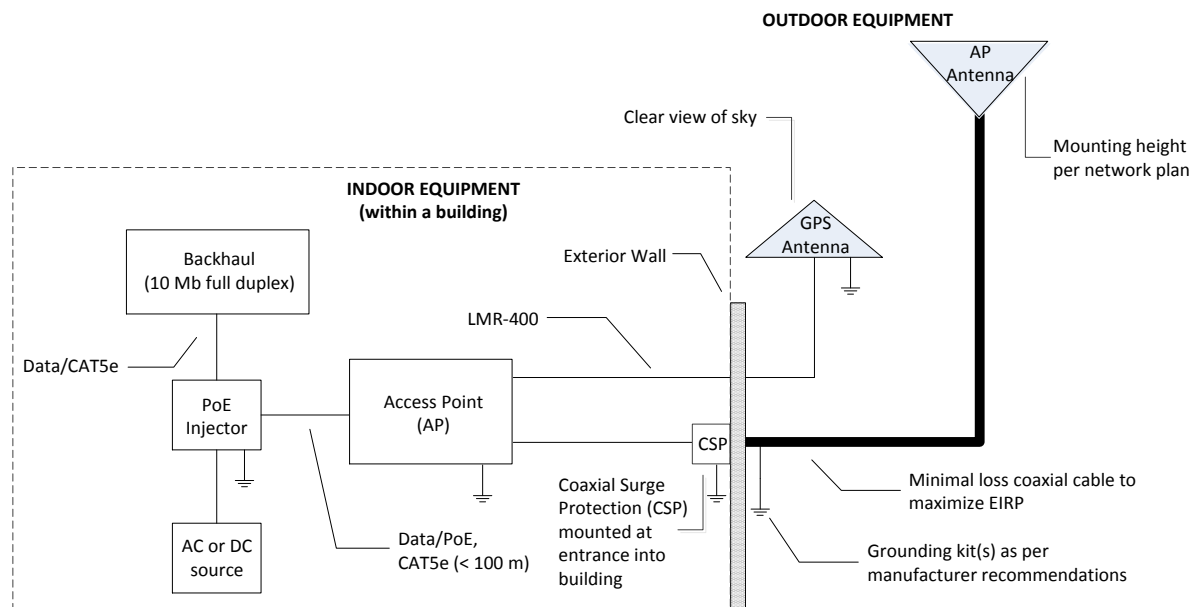
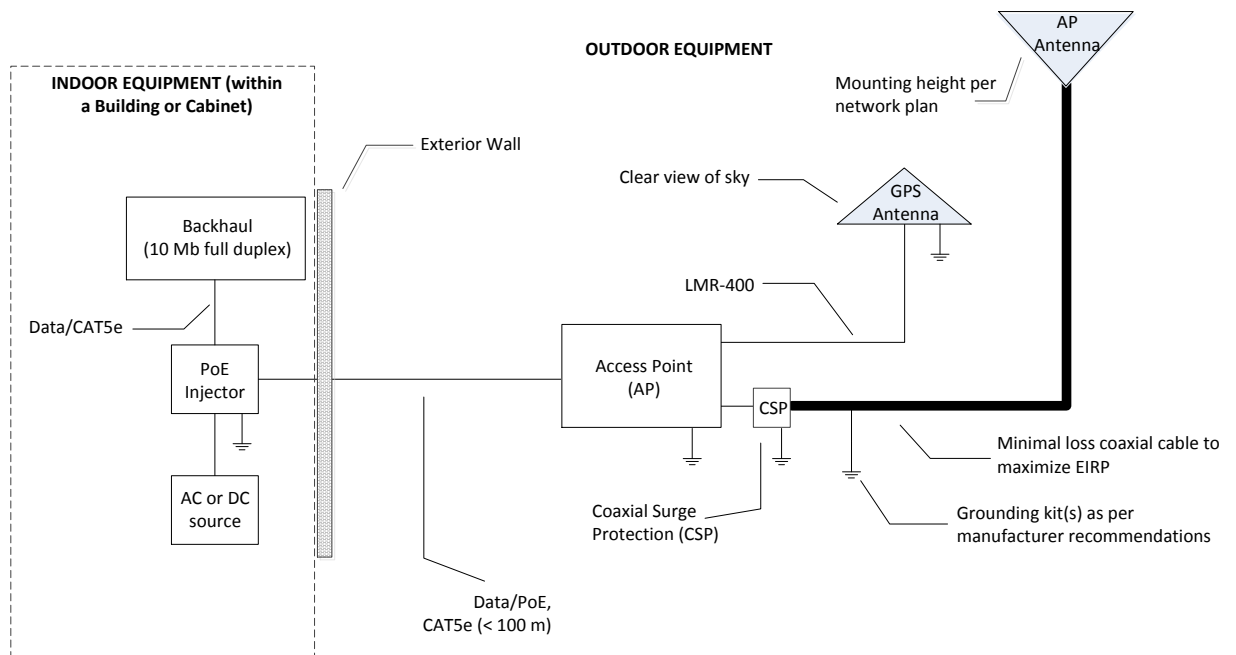

Figure 2. High Level Diagram for Indoor Site Installation of AP and Equipment



**Figure 3. High Level Diagram for Outdoor Site Installation of AP and Equipment**

**NOTE:** The AP does not contain any user-serviceable components. Opening the AP voids the product warranty.

For questions or technical assistance, contact Ingenu at [support@ingenu.com](mailto:support@ingenu.com).

## 1.2 Referenced Documents

The following document provides additional details about the AP.

- **Access Point Product Specification (014-0030-00)**  
Provides detail about product specifications, characteristics, and requirements for the AP.
- **EMS Operator Guide (010-0045-00)**  
Provides instruction on using Ingenu Element Management System (EMS) to manage and monitor the Access Point. This document should be used for Access Point day-to-day operations and monitoring.

## 2 Network Planning and Configuration Considerations

---

Prior to the installation of an AP at a new location, a number of network design and configuration decisions must be addressed. This chapter provides an overview of these decisions which should be reflected in the AP Installation Configuration Worksheet provided in [Appendix B](#). Detailed network planning and configuration is outside the scope of this document.

### 2.1 Network Planning

Network planning is critical to a successful AP installation and the reliable operation of an On-Ramp Total Reach Network. The following issues must be addressed in the network planning and design process.

- Determine network coverage requirements
- Establish network reliability requirements
- Select and approve site and antenna locations
- Predict TRN coverage with a propagation model
- Select the appropriate AP antennas
- Select the AP antenna cable type, determined by cable length, to minimize loss
- Assign AP channel (frequency) and Reuse Code
- Determine antenna cable attenuation
- Determine AP transmit power setting
- The maximum permissible Effective Radiated Power, ERP, is determined by the regulations for the country where the AP will be installed (e.g., ETSI, FCC). The actual ERP is determined by the AP's transmit power output, antenna gain and antenna cable loss.

**NOTE:** The maximum ERP authorized by the FCC in the United States is +36 dBi.

### 2.2 Network Configuration

The following AP network configuration settings must be determined by your network planning and configuration team and provided for AP configuration. These settings can be set via the AP web interface (shown in chapter 7) or in EMS (refer to the *EMS Operator Guide, 010-0045-00*), except as noted below:

- Site Name **NOTE:** The site name is for reference only and is not set in the AP or in EMS.
- AP ID
- System ID

- Client or Server Mode operation
- Static or DHCP IP address assignment
- AP IP address, if static
- Netmask setting
- Default router
- DNS servers
- NTP servers
- Server port number
- Gateway Hostname or IP Address
- Gateway port number
- Channel assignment
- Reuse Code (Allows AP coexistence on the same channel)
- AP antenna cable attenuation in dB
- Transmit output power setting, most frequently automatically set by inserting antenna cable loss in dB when using the standard antenna for the country of operation. In the United States the standard antenna's gain is 9 dBi.

## 2.3 Backhaul

Backhaul is the interconnection of the APs in a network to the back office systems including the On-Ramp gateway and the element management system. The backhaul method to be used must be determined for each AP prior to installation. Common backhaul methods include the following:

- Cellular/PCS 3G data modems
- Existing Ethernet infrastructure
- DSL links
- Point-to-Point radio links
- Microwave links

**NOTE:** A 10/100 Mb IP-over-Ethernet connection with 128 Kbps minimum throughput is required.

## 3 Installation Prerequisites and Considerations

---

Before starting the actual physical installation of an AP, it is very important to complete the prerequisite tasks outlined in this chapter as well as take into account the installation considerations indicated. Information gathering templates are provided in the appendices of this document.

### 3.1 Installation Prerequisites

#### 3.1.1 Site Survey

A site survey should be conducted prior to installation for all AP sites. The site survey provides detailed, site-specific, information required to plan an AP installation and should be documented. See [Appendix A](#) for a Site Survey Worksheet template. A copy of this worksheet should be provided to the installer.

A site survey provides:

- Site name
- AP ID
- Site street address or other location
- Site access information
- Landlord contact information
- Specific landlord requirements
- Latitude
- Longitude
- Site type (building, tower, pole, or other)
- Height of existing structure
- AP and equipment mounting locations
- AP antenna mounting location and height
- Antenna line length required
- GPS antenna mounting location
- GPS antenna cable length
- AP power type, commercial power, solar solution or other
- Distance to available power
- Photos of site including antennal location, AP location, and the overall site
- Other site-specific information

#### 3.1.2 AP Installation Configuration

The AP installation configuration should be documented and provided to the installer prior to the start of the installation. See [Appendix B](#) for an AP Installation Configuration Worksheet template. This worksheet provides the following site-specific equipment details and AP configuration information:

- Site name
- AP ID
- Deployment Region ID
- AP physical configuration (outdoor, indoor, and base station type)
- Power source (120/240 VAC, 48 VDC, or Solar)
- AP antenna gain
- AP antenna downtilt, if required
- AP antenna cable type
- AP antenna cable length
- AP antenna cable loss
- GPS antenna model
- GPS cable type

- AP antenna manufacturer
- AP antenna model
- Backhaul type
- Backhaul equipment location
- Backhaul configuration information
- AP and other equipment installation location
- Ethernet cable type and length, if required
- AP IP Address type, Static or Dynamic
- AP IP Address assignment, if static
- Netmask setting
- GPS cable length
- Default router
- DNS servers
- NTP servers
- Client or server mode of operation
- Gateway hostname or IP address
- Gateway port number
- Server port
- Channel assignment
- Reuse code

## 3.2 Installation Considerations

When planning a new AP installation, the following items must be considered.

### 3.2.1 AP Antenna

The AP antenna should be mounted at a location that minimizes physical obstructions between the antenna and the endpoints with which it will be communicating. Rooftop installations create the largest concern in this area. Antenna placement and height are very important to maximize network performance. The AP antenna should be securely mounted in a vertical position. The AP antenna cable is connected to a type-N female connector on the AP.

There are a variety of antenna options available to address the regulatory requirements of different countries. See the *Access Point Product Specification (014-0030-00)* for additional details.

### 3.2.2 AP Antenna Cable

A 50 ohm low loss coaxial cable is used to connect the antenna to the AP. The type of cable is selected based on the length of the cable run and network design requirements. For short runs, a ½ inch cable such as Andrew LDF4-50A is recommended. For longer runs, a 7/8 inch cable or 1 ¼ inch cable may be used to reduce the cable attenuation.

The antenna cable should always be attached to the tower or other structure with clamps at the spacing recommended by the manufacturer. It is also very important to maintain the minimum bending radius recommended by the manufacturer to avoid kinking the cable during installation.

When using an antenna cable larger than ½ inch, ½ inch LDF4-50A jumpers with type-N male connectors, typically 3 feet to 6 feet long, should be installed between the antenna cable and both the antenna and the AP to minimize the chance of damage to their connectors. The AP and the AP antenna use type "N" female connectors.

**NOTE 1:** The total RF cable loss from AP Antenna connector to the antenna must be calculated or measured with antenna system test equipment during installation as detailed in section [6.3 Antenna System Sweep Testing](#). This value in dB is used when configuring the AP in the EMS.

**NOTE 2:** All outdoor antenna cable connections must be weather sealed in an appropriate manner. The table below shows the attenuation for common types of antenna lines.

**Table 2. Attenuation at 2.4 GHz for Common Types of Antenna Cables**

Model	Size	dB/25 ft	dB/50 ft	dB/100 ft	dB/150 ft	dB/200 ft
LMR-400	.40 inch	1.7	3.4	6.8	10.2	13.6
FSJ4-50B	½ inch	1.5	3.1	6.1	9.2	12.2
LDF4-50A	½ inch	.9	1.9	3.7	5.6	7.4
AVA5-50	7⁄8 inch	.5	1.0	1.9	2.9	3.8
AVA7-50	1½ inch	.3	.6	1.2	1.8	2.4

### 3.2.3 GPS Antenna

The GPS antenna provides timing signals to the AP. It should be mounted so that it has a clear view of the sky. A mounting location should be chosen that minimizes shadowing from trees or structures.

**NOTE:** The GPS antenna should be mounted at least one meter away from the AP antenna to minimize the chance of interference.

In normal operation, the AP requires GPS synchronization for precision timing of all nodes on the network. To provide a reliable GPS signal, the AP has a built-in GPS receiver which requires an externally connected GPS antenna. The GPS antenna cable is connected to a type-N female connector on the AP.

Many different GPS antennas are available but Ingenu recommends using the PCTEL GPS antenna model GPSL1-TMG-SPI-40NCB for the following reasons:

1. The PCTEL GPS antenna has a low noise, high gain amplifier which is well-suited to address cable attenuation when the GPS antenna mounting location requires a long length of cable. Up to a 20 dB cable loss is acceptable when using this high gain antenna.
2. The PCTEL GPS antenna provides integrated, onboard, lightning protection that minimizes the need for a downstream, inline surge suppressor. The GPS antenna must be properly grounded. See figure 4. If using an external surge suppressor, it must be a “DC pass-through” type.

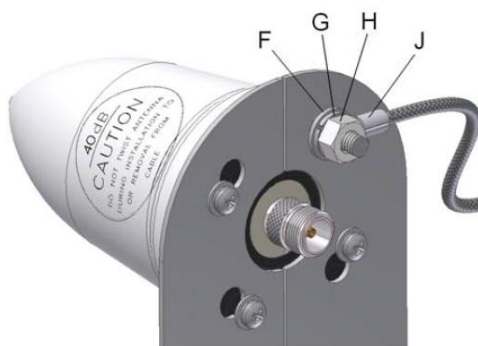

**Figure 4. PCTEL GPS Model GPSL1-TMG-SPI-40NCB**



The PCTEL GPSL1-TMG-SPI-40NCB GPS antenna has a type-N female connector.

**NOTE:** Most GPS antennas have a Low Noise Amplifier (LNA) that requires power from the AP. The AP supplies 3.3 V at up to 50 ma. If this current is exceeded, the AP detects the excess current and shuts down its GPS power supply. When this occurs, the AP sends a GPS antenna fault message back to the EMS. The AP must be power cycled to restore power to the GPS antenna.

### 3.2.4 Antenna Cable Lightning Suppression and Grounding

A coaxial surge suppressor must be installed at the location shown in the table below and must be connected with a #10 gauge or larger stranded wire to an appropriate ground for lightning protection. In most tower installations the outer shield of the AP antenna cable must be grounded with one or more grounding kits provided by the antenna cable manufacturer. The grounding kits must be connected to appropriate building or tower grounds using a #2 gauge wire. The mounting pipe for the antenna should be grounded to the same point if it is not attached to a grounded structure.

**Table 3. Surge Protector Mount Locations**

Coaxial System Mount Location	Mount Location of Surge Protector
Indoors	Entrance to the first external wall
Outdoors	Antenna connector of the Access Point
Outdoor Enclosure	Entrance to the enclosure

### 3.2.5 AP DC Power Requirement

The AP is powered over the Ethernet port using a PoE injector. The acceptable power source voltage range is 38 – 72 VDC. At the nominal input voltage of 48 VDC the typical input current is 0.3 Amps. The maximum input power dissipation is 17 Watts. When connecting to the distribution panel of a 48 VDC power system, it should be fused with a minimum of a ½ Amp slow-blow fuse. The maximum fuse or circuit breaker size should be 2 Amps.

### 3.2.6 PoE Injector

A standard PoE (Power over Ethernet) injector is used to apply power to the AP. An example of an approved device is the L-com HyperLink BT-CAT5-P1 Single-Port CAT-5 Midspan/Injector (also known as PoE Passive Splitter). When connected to an outdoor AP the PoE injector must be properly grounded for lightning and surge protection.

The following figure illustrates a typical setup utilizing the PoE injector.

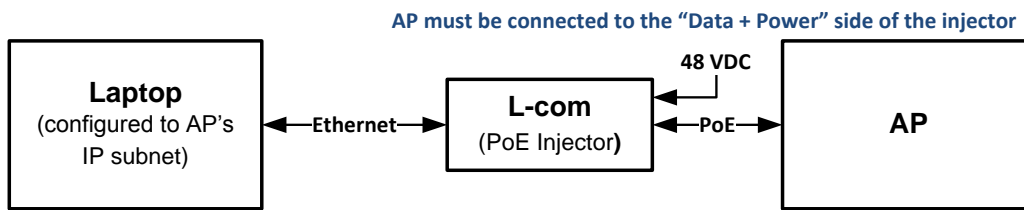

Figure 5. Block Diagram Showing PoE Injector Connections

### 3.2.7 Ethernet Cable

The Ethernet cable connection to the AP provides both data and DC power. The maximum Ethernet cable length is 328 feet (100 meters). A quality Cat5e or Cat6 cable is required. For most applications, an Unshielded Twisted Pair (UTP) cable with solid conductors is recommended.

**NOTE:** Shielded Ethernet cable is not recommended.

The following table provides a list of tested Ethernet cables and connector combinations.

Table 4. Tested Ethernet Cable and Connector Combinations

Cable Type	Manufacturer Part Number	RJ45 Connector Type	Manufacturer Part Number
CAT 5E, UTP Stranded, 24AWG Cable	10X6-021SH <a href="http://www.CableWholesale.com">www.CableWholesale.com</a>	CAT 5E UTP RJ45 Connectors, for Stranded Cable	SW-22342 <a href="http://sewelldirect.com">http://sewelldirect.com</a>
CAT 5E UTP Solid, 24 AWG Cable	DC-5E8-RD-1K-L Pan Pacific <a href="http://www.wallcoinc.com">www.wallcoinc.com</a>	CAT 5E UTP RJ45 Connectors, for Solid Cable	CN150-45-1 Mfg: Abergetty Supplied by: <a href="http://www.deepsurplus.com">www.deepsurplus.com</a>
CAT 5E, STP Solid, 24AWG Cable	10X6-521TH <a href="http://www.CableWholesale.com">www.CableWholesale.com</a>	CAT 5E STP RJ45 Connectors, for Solid Cable	SW-22350 <a href="http://sewelldirect.com">http://sewelldirect.com</a>
CAT 5E, STP Stranded, 24AWG Cable	10X6-521SH <a href="http://www.CableWholesale.com">www.CableWholesale.com</a>	CAT 5E STP RJ45 Connectors, for Stranded	CN150-45-11 Mfg: Abergetty Supplied by: <a href="http://www.deepsurplus.com">www.deepsurplus.com</a>
CAT 6, UTP Stranded Cable	10X8-071SH <a href="http://www.CableWholesale.com">www.CableWholesale.com</a>	CAT 6 UTP RJ45 Connectors, for Stranded Cable	SW-22346 <a href="http://sewelldirect.com">http://sewelldirect.com</a>
CAT 6, UTP Solid Cable	10X8-081TH <a href="http://www.CableWholesale.com">www.CableWholesale.com</a>	CAT 6 UTP RJ45 Connectors, for Solid Cable	CN150-45-4 Mfg: Abergetty Supplied by: <a href="http://www.deepsurplus.com">www.deepsurplus.com</a>

Cable Type	Manufacturer Part Number	RJ45 Connector Type	Manufacturer Part Number
CAT 6 STP Solid	10X8-591NH <a href="http://www.CableWholesale.com">www.CableWholesale.com</a>	CAT 6 STP RJ45 Connectors, for Solid Cable	CN150-45-10 Mfg: Abergetty Supplied by: <a href="http://www.deepsurplus.com">www.deepsurplus.com</a>

**NOTE:** It is very important that connectors be specified for the cable being used. As an example, if using Cat5e solid conductor cable, the connectors should be specified for Cat5e solid conductor cable. Some connectors are specified for both solid and stranded conductors. Always use an RJ45 crimping tool that is specified for use with the connectors being used.

During the installation of the Ethernet cable, a pulling force of 25 pounds should not be exceeded. The bending radius of the cable should never be less than four times its diameter. Ethernet cable should not be deformed by tightly cinched cable ties.

Shielded Ethernet cable may be required in cases where the cable is installed in close proximity to equipment or conductors generating strong electromagnetic fields. In this case follow Shielded Twisted Pair (STP) installation guidelines.

### 3.2.8 Solar Power

Solar Power is recommended for sites where commercial power is not available or is not cost effective to install. The required size for the solar panel and battery system is strongly influenced by the geographic area in which it will be used. Ingenu offers a solar powered base station solution that may be appropriate for your application. Contact Ingenu at [support@ingenu.com](mailto:support@ingenu.com) for more information.

### 3.2.9 Outdoor Installation Hardware

All outdoor installation hardware such as mounting brackets, pipe clamps, u-bolts, bolts, nuts and washers should either be galvanized or stainless steel. This reduces deterioration due to corrosion, oxidation, and rust.

**NOTE:** All exposed antenna system connectors must be sealed against moisture using industry standard techniques.

## 4 Regulatory Warnings

---

### 4.1 Certifications

The AP is designed to meet regulations for world-wide use. For information on the most current certifications, refer to the *Access Point Product Specification (014-0030-00)*. A brief summary of current certifications is below.

**Table 5: AP installation configurations & domains**

Configuration	Regulatory Domain	Comments
FCC Single High Capacity	FCC	FCC ID: XTE-ULPAP <sub>110</sub>
Sectorized	FCC	FCC ID: XTE-ULPAP <sub>210</sub>
Dual Latency	FCC	FCC ID: XTE-ULPAP <sub>310</sub>
ETSI Single High Capacity (Generic)	ETSI	10dBm EIRP
ETSI Single High Capacity (RFID)	ETSI	27dBm EIRP

### 4.2 Transmit Power Restrictions

Transmit power restrictions vary by country/agency. For details about antenna and transmit power restrictions, refer to the *Access Point Product Specification (014-0030-00)*.

### 4.3 FCC Warnings – United States

This device complies with part 15 of the Federal Communications Commission (FCC) Rules. Operation is subject to the following two conditions:

3. This device may not cause harmful interference.
4. This device must accept any interference received, including interference that may cause undesired operation.

Changes or modifications not expressly approved by the manufacturer could void the user's authority to operate the equipment.

**NOTE:**

This equipment has been tested and found to comply with the limits for a Class B digital device, pursuant to Part 15 of the FCC Rules. These limits are designed to provide reasonable protection against harmful interference in a residential installation.

**WARNING:**

This equipment generates, uses, and can radiate radio frequency energy. If not installed and used in accordance with the instructions, this equipment may cause harmful interference to radio communications. However, there is no guarantee that interference will not occur in a particular installation. If this equipment does cause harmful interference to radio or television reception, which can be determined by turning the equipment off and on, the user is encouraged to try to correct the interference by one or more of the following measures:

- Re-orient or relocate the receiving antenna.
- Increase the separation between the equipment and receiver.
- Connect the equipment into an outlet on a circuit different from that to which the receiver is connected.
- Consult the dealer or an experienced radio/TV technician for help.

## 4.4 IC Warnings - Canada

The installer of this radio equipment must ensure that the antenna is located or pointed so that it does not emit RF field in excess of Health Canada limits for the general population. Consult Safety Code 6 which is obtainable from Health Canada's website <http://www.hc-sc.gc.ca/index-eng.php>.

Operation is subject to the following two conditions:

5. This device may not cause harmful interference.
6. This device must accept any interference received, including interference that may cause undesired operation.

To reduce potential radio interference to other users, select the antenna type and its gain so that the equivalent isotropically radiated power (EIRP) is not more than that permitted for successful communication.

**Canadian Two Part Warning Statement:**

This device complies with Industry Canada licence-exempt RSS standard(s). Operation is subject to the following two conditions: (1) this device may not cause interference, and (2) this device must accept any interference, including interference that may cause undesired operation of the device.

*Le présent appareil est conforme aux CNR d'Industrie Canada applicables aux appareils radio exempts de licence. L'exploitation est autorisée aux deux conditions suivantes : (1) l'appareil ne doit pas produire de brouillage, et (2) l'utilisateur de l'appareil doit accepter tout brouillage radioélectrique subi, même si le brouillage est susceptible d'en compromettre le fonctionnement.*

## 4.5 RF Exposure Statement

**FCC ID: XTE-ULPAP110. IC: 8655A-ULPAP110.** This device is only authorized for use in fixed and mobile applications. To meet FCC and other national radio frequency (RF) exposure requirements, the antenna for this device must be installed to ensure a separation distance of at least 20cm (8 inches) from the antenna to a person.

**FCC ID: XTE-ULPAP210.** This device is only authorized for use in fixed and mobile applications. To meet FCC and other national radio frequency (RF) exposure requirements, the antenna for this device must be installed to ensure a separation distance of at least 25cm (10 inches) from the antenna to a person.

**FCC ID: XTE-ULPAP310. IC: 8655A-ULPAP310.** This device is only authorized for use in fixed and mobile applications. To meet FCC and other national radio frequency (RF) exposure requirements, the antenna for this device must be installed to ensure a separation distance of at least 36cm (15 inches) from the antenna to a person.

# 5 AP Installation

---

## 5.1 AP and Ancillary Equipment

The AP installation includes installing the AP itself and the ancillary equipment listed below:

- Access Point (AP)
- AP antenna
- AP antenna cable (50 ohm coaxial cable)
- AP antenna cable lightning suppressor
- GPS antenna
- GPS antenna cable (50 ohm coaxial cable)
- PoE injector, powered by 48 VDC
- Site-specific power solution providing 48 VDC to the PoE, if not using the 120/240 VAC powered base station cabinet or the solar powered base station
- Backhaul equipment
- Site-specific mounting hardware

**NOTE:** Ingenu recommends that a backup power solution be utilized to power the AP in the event of a power failure. The backup power solution should be designed to meet customer requirements for the number of hours of backup power.

## 5.2 AP Certified Configurations

The AP RF subsystem operates as a half-duplex transceiver. The SPDT switches allow connection from the antenna to one of three paths:

- TX high power
- TX low power
- RX

The Cavity Filter is only used in the FCC/IC configuration, specifically to avoid the 2483 MHz Restricted Band when near max power. It also provides excellent out-of-band rejection. [The AP can also be used in some markets in a Sectorized configuration \(FCC\) or a Dual Latency configuration \(FCC/IC\).](#)

## Single High Capacity AP

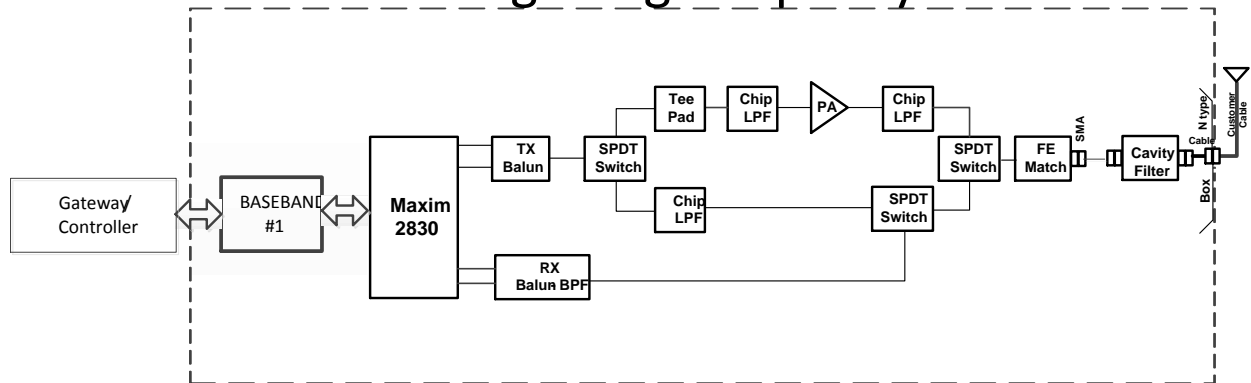

Figure 6. AP Radio Block Diagram for FCC/IC

## Sectorized AP

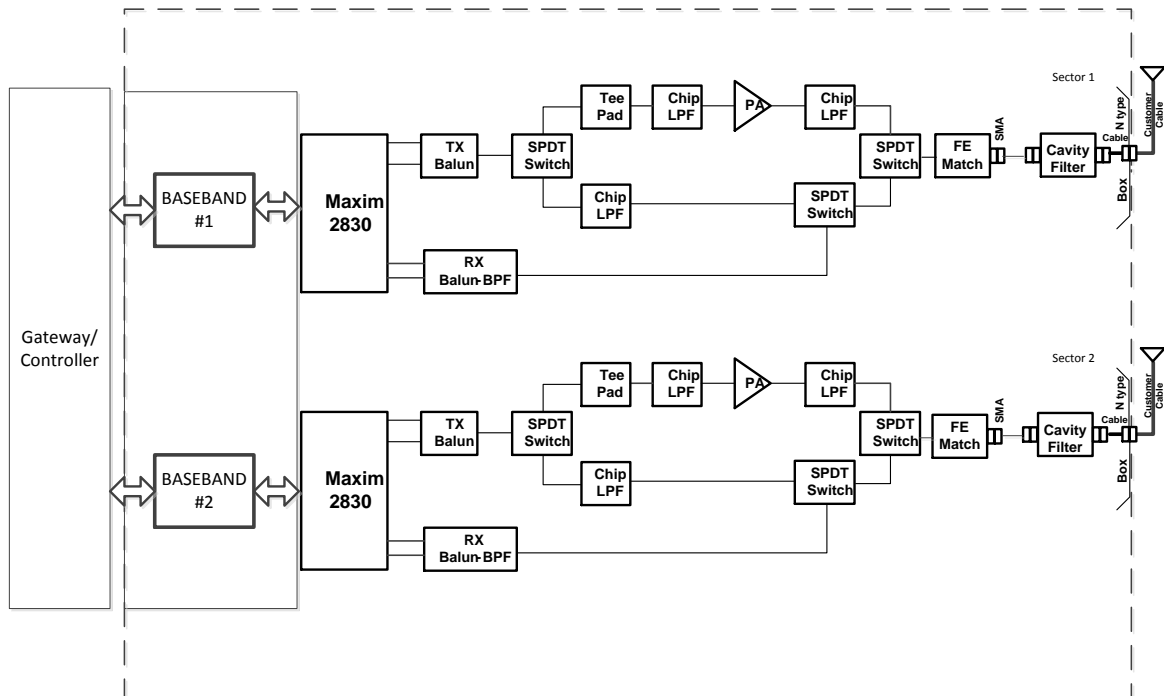

Figure 7: Sectorized AP Block Diagram for FCC Only



### Dual Latency AP

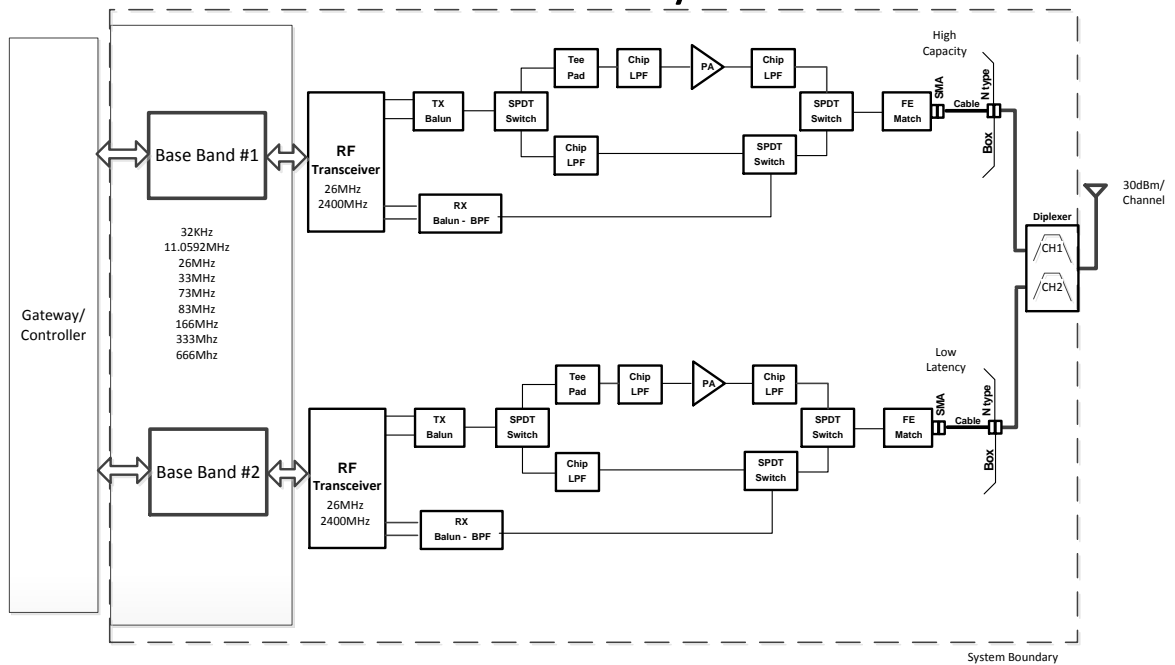

Figure 8: Dual Latency Block Diagram for FCC/IC

### Single High Capacity AP

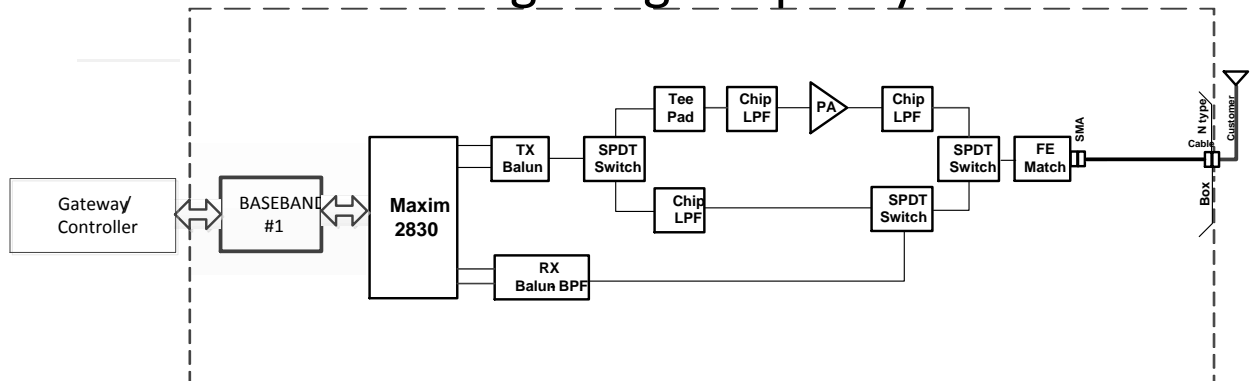

Figure 9. AP Radio Block Diagram for ETSI/Japan (no Cavity Filter)

## 5.3 AP Installation Configurations

The small size of the AP (9.1"H x 8.1"W x 4.5"D) and light weight allows for many installation configurations. For basic AP specifications, refer to [Appendix C](#). The AP is designed to be installed indoors or outdoors. It may be mounted in any position indoors but should be mounted with its connectors facing down when installed outdoors. The AP may be installed in an equipment cabinet with its ancillary equipment if desired.

Types of installation configurations include:

- Outdoor non-penetrating roof mounts on building
- Indoor or outdoor wall attachment
- Pipe mounting
- Tower mounting
- Utility pole mounting

## 5.4 Base Station Configurations

Ingenu offers pre-configured base station packages. For details, refer to [Appendix D: Base Station Configuration](#).

## 5.5 General Grounding Guidelines

The following grounding information is provided as a guideline when installing the AP in any configuration.

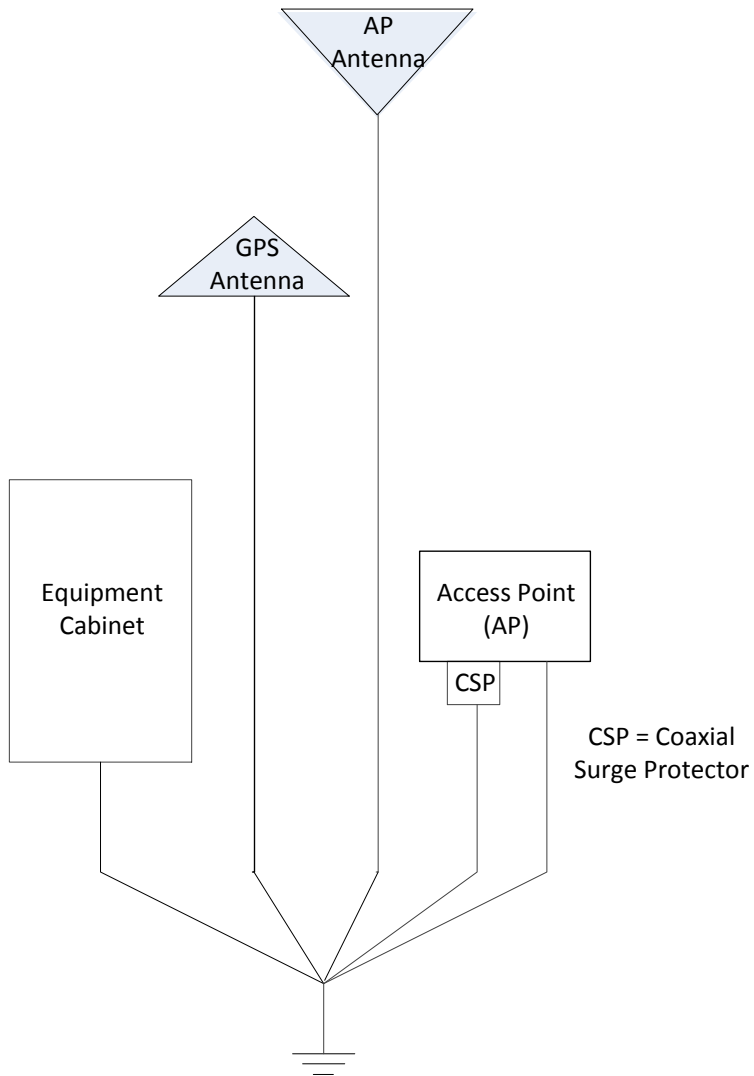

Figure 10. High Level Grounding Diagram

### 5.5.1 Grounding the AP and Antenna Cable Surge Suppressor

A ground wire may be attached underneath one of the AP mounting bolts. A ground wire must be attached to the ground terminal on the inline coaxial surge protector which is inserted between the AP's type N female antenna connector and the AP antenna cable. An example is shown in the following figure.

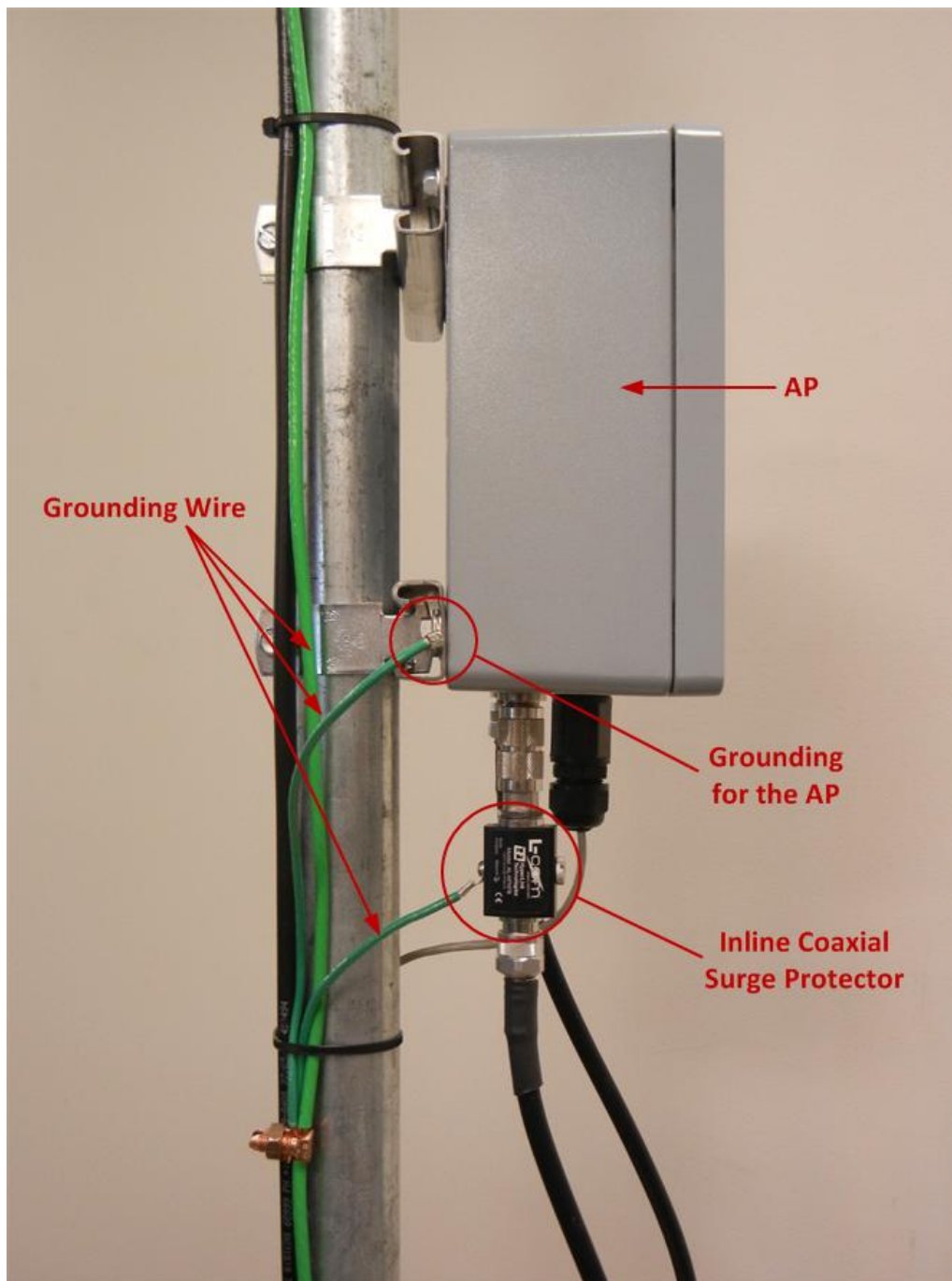

Figure 11. Grounding the AP

## 5.5.2 Grounding the AP and GPS Antennas

If the AP and GPS antennas are not attached to grounded metal structures a ground wire should be attached to the base of both antennas. An example of grounding these two antennas is shown in the following figure.

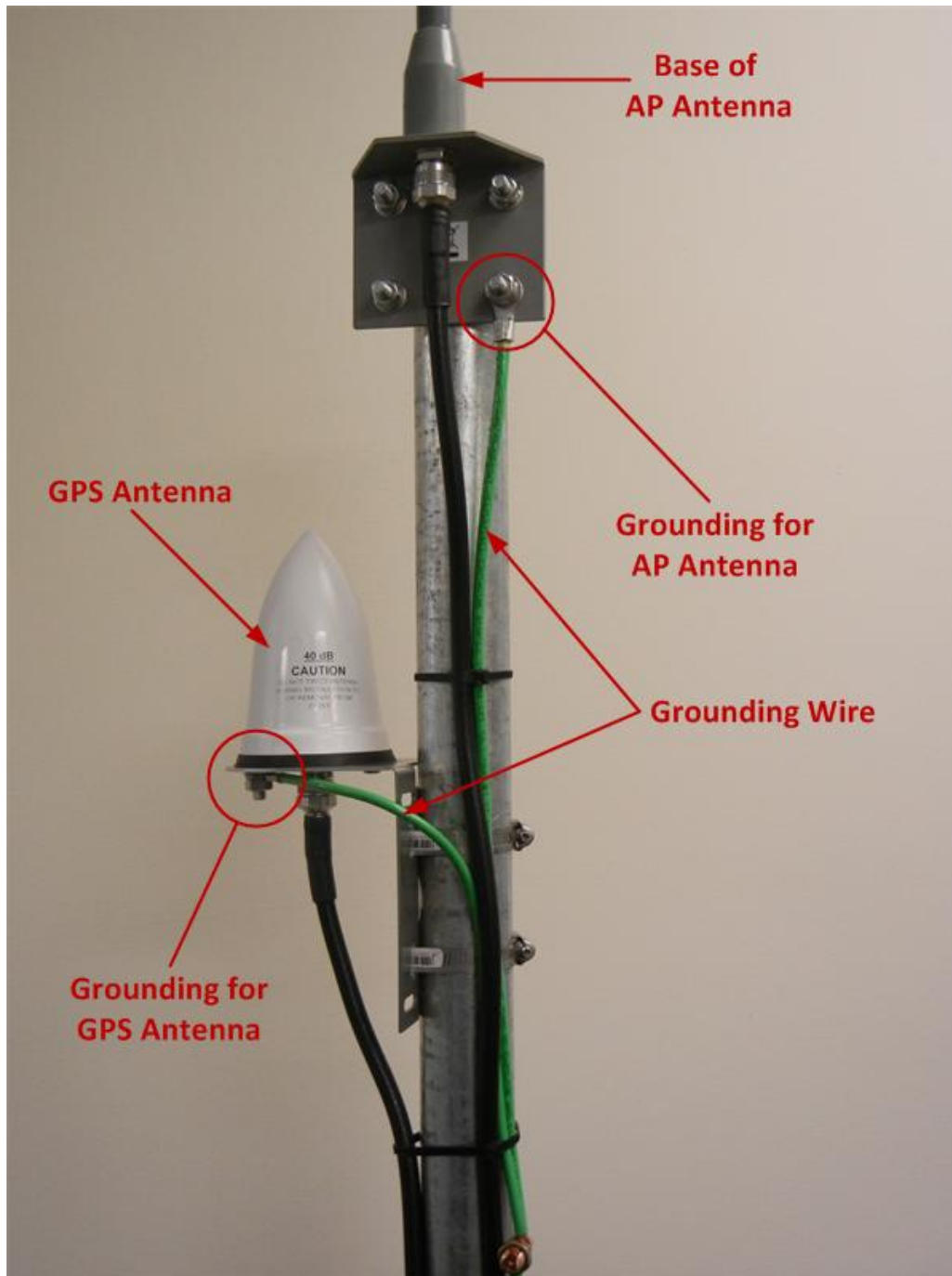

Figure 12. Grounding the GPS and AP Antennas

## 5.6 AP Mounting Details

Mounting options for the AP are discussed in this section. The AP is supplied with four mounting tabs that facilitate attaching the AP to a wall, in a cabinet, or to a strut channel, if required. The mounting tabs are attached to the AP by the installer using four provided, 5/16 inch self-tapping, hex head bolts. See the mounting tabs shown in [Error! Reference source not found.](#)



Figure 13. AP with Mounting Tabs Installed

## 5.7 AP Pipe Mount Option

Ingenu offers an optional pipe mount kit for the AP. This kit provided two 8-inch lengths of strut channel that have been drilled to allow attachment to the top and bottom holes on the back of the AP. The same self-tapping bolts provided with the AP are used to attach the strut channel in place of the mounting tabs. After attaching the strut channel to the AP, it can now be attached to any size of pipe using standard strut channel pipe clamps or conduit clamps.

# 6 Hardware Installation Verification

## 6.1 Power Verification

Prior to applying power to the AP, confirm with a Digital Voltmeter (DVM) that the DC voltage is correct at the PoE injector. The DC voltage should be between 48 VDC and 54 VDC.

**NOTE:** The AP its self is not polarity sensitive, however, it is recommended that the barrel of the PoE power plug be at ground potential if the power system is grounded.

## 6.2 AP Antenna and GPS Cable DVM Test

Prior to weather sealing the AP antenna and GPS antenna connectors, disconnect both cables at both ends and verify continuity between center pins and verify that neither cable is shorted.

## 6.3 Antenna System Sweep Testing

The combined TRN antenna system (including the antenna, cables, and lightning suppressor) should be "sweep tested" for Return Loss and Attenuation using an antenna analyzer such as an Anritsu Site Master™. The antenna system should be swept across the frequencies of interest, 2.400 GHz – 2.480 GHz. The Return Loss should be greater than 17 dB across the frequency range and the total attenuation should be as low as possible, generally less than 5 dB. The antenna system attenuation (loss) should be noted for use when configuring the AP within the EMS system.

If the Return Loss is not acceptable, the antenna should be disconnected and the antenna line should be terminated with a 50 ohm load. The Return Loss test should be repeated. If the antenna line Return Loss is now greater than 20 dB and is flat across the frequency range, the antenna should be replaced. If the Return Loss is not acceptable, the antenna cable system should be tested using the Distance to Fault (DTF) capability in the antenna analyzer to locate the problem.

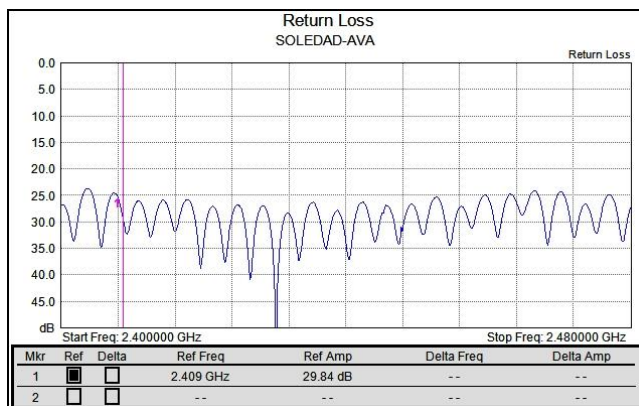

**Notes:**

- Measurement is required to be > 20 dB for coaxial cable and connectors.
- Overall return loss with antenna should be > 17 dB.

Figure 14. Return Loss

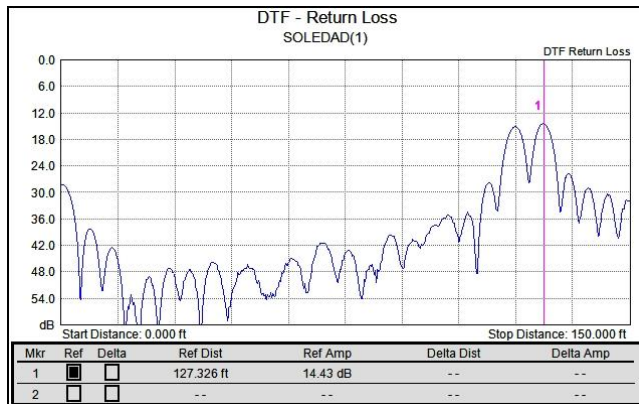

**Notes:**

- Measurements should be taken with the antenna as well as with a 50Ω terminating load.
- Type and length of coaxial cable should be recorded for each run.

Figure 15. Distance to Fault

## 6.4 Grounding

Verify that the mounting hardware, AP, antenna cable, and lightning suppressor are properly grounded.

## 6.5 Connector Weather Sealing

Verify that all outdoor connectors are properly weather sealed.

## 6.6 Mounting Hardware

Verify that all mounting hardware is tight and secure.



# 7 AP Software Configuration via Web Interface

---

The AP web interface can be accessed with a web browser connected locally at the data port of the PoE injector or remotely through the backhaul network. Ingenu recommends that you use one of the following internet browsers when using the AP web interface:

- Microsoft Internet Explorer® 8 or higher
- Mozilla Firefox®, any version
- Google Chrome™, any version

**NOTE:** The AP web interface described in this chapter is compatible with AP software version 6.6.0 and System Release 2.1.

## 7.1 Initial AP Network Configuration Prior to Installation

The AP is shipped with the following factory default IP Network Settings:

- IP Address: 192.168.1.1
- Netmask: 255.255.255.0
- Default Router: 192.168.1.254

This section covers the minimum IP network configuration required to establish remote connectivity with the AP. This configuration must be performed prior to AP installation or on-site immediately following the physical AP installation. In most cases, it is strongly recommended that the initial configuration be performed prior to installation.

Refer to [Figure 5](#) for the connections required to configure an AP. If the AP is being installed with a 3G wireless modem for backhaul, refer to section [7.1.1](#). If the AP is being installed with any other type of customer-provided IP backhaul, refer so section [7.1.2](#).

### 7.1.1 Initial AP Network Configuration for 3G Wireless Backhaul Modem

When activating the 3G wireless modem, a static IP address is required from the wireless carrier. The LAN side of the 3G modem can be configured to support the default IP network settings of the AP. This avoids the need to change these default settings in the AP. After the AP is installed, a connection to the AP can be established using the IP address of the 3G modem and the AP can be configured remotely. Refer to the *Ingenu 3G Modem Configuration Guide* for additional information.

### 7.1.2 Initial AP Network Configuration for Customer Backhaul Modem

The default IP network settings for the AP must be changed to allow connection to the AP over the customer's IP network. To make these changes, perform the following steps:

7. Log into the AP as described in section 7.2.
8. After successfully logging into the AP, select "Admin" in the upper right corner of the screen.
9. From the Admin menu, select the Network submenu.
10. Follow the instructions in section 7.6.2 to make the required changes to the IP address, Netmask, and Default Router.
11. When you have completed the changes, be sure to click on the **Save** button and then click on the **Reboot Access Point** button.
12. After these changes are made and the customer's firewall and routers have been properly configured, the AP can be remotely configured.

For additional support with AP configuration, contact the Ingenu's Network Operations Center (NOC) Team at [support@ingenu.com](mailto:support@ingenu.com).

## 7.2 Login

The AP has a factory default IP Address of 192.168.1.1 which allows connection to the AP configuration page using https protocol on port 443.

13. To access the AP configuration page, ensure the following:
  - ❑ You are on the same subnet with the AP or your router can route to the AP IP address. The AP's default router setting is 192.168.1.254.
  - ❑ You have access to port 443 on the firewall
14. Open your web browser.
15. In the address bar of the browser, type <https://192.168.1.1>. A dialog box opens that looks similar to the following:

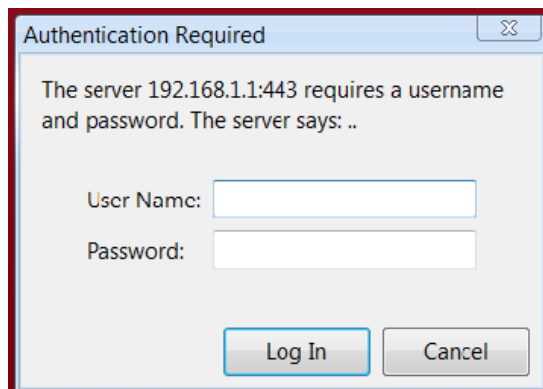
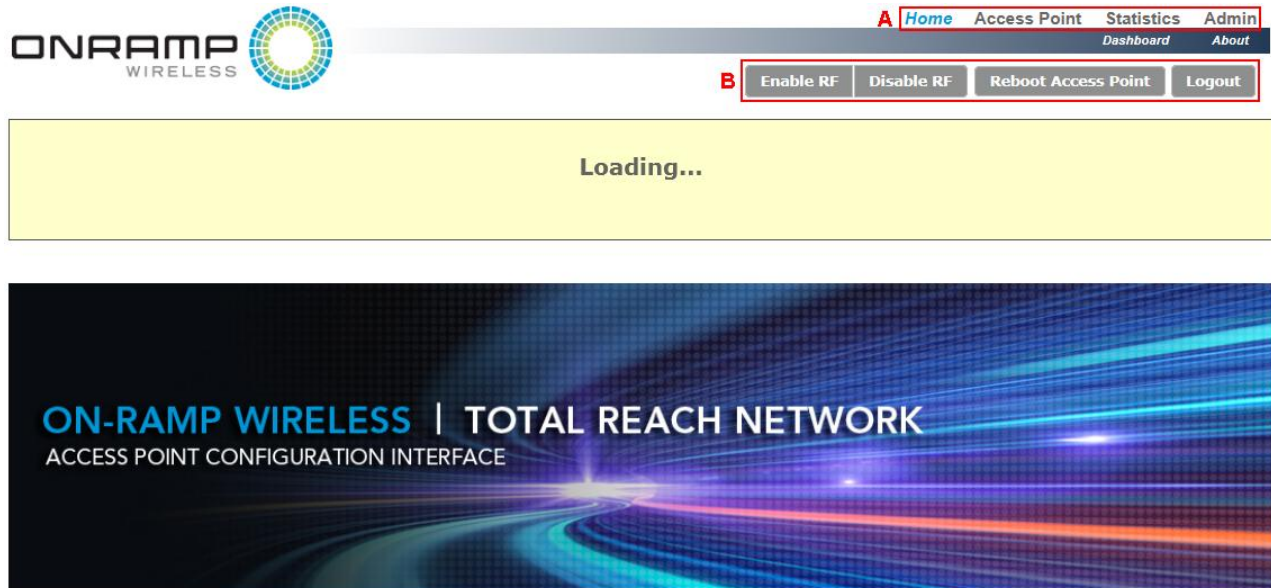

**Figure 16. Username and Password Prompt**

16. Enter the default User Name and Password.  
User Name: `admin`  
Password: `onramp`
17. Click on the **Log In** button.

**NOTE:** After you log in, Ingenu recommends that you change from the default password to a personalized password. For instructions on how to do this, refer to section [7.6.1 Security Submenu](#).

18. After logging in, the home page displays as shown below.



**Block A** above shows the four menus (i.e., Home, Access Point, Statistics, and Admin) that can be used to navigate to different configuration pages.

**Block B** shows four buttons that allow you to do the following:

- ❑ **Enable/Disable RF**  
If the RF is disabled, the AP is still connected to the Gateway.
- ❑ **Reboot the AP**  
After making configuration changes, this button is used to reboot the Access Point in order for the changes to take effect.
- ❑ **Logout**  
This button allows you to completely log out of the system.

All of the menus and their submenus are described in the following sections.

**NOTE:** After logging in, the following information is displayed at the top of all screens: Access Point ID, current date, software and firmware versions, and site name.

Additionally, there is a “status box” that provides the following information: AP status, network state, Gateway ID, backhaul state, backhaul mode, RF state, and GPS state.

Access Point Id : 00:25:0F:03:02:32  
 Mon Apr 01 2013 21:49 GMT

Software v6.0.4 Firmware 0x1079 Build 48277M  
 Site Name : jignesh-ap1

Home Access Point Statistics Admin  
 Dashboard About

RF Enabled Disable RF Reboot Access Point Logout

**AP Status : ONLINE**

Network State : registered  
 Gateway Id : a628ff4f-9632-4304-9d84-b093a89bc18f

Backhaul State : connected  
 Backhaul Mode : client

RF State : online  
 GPS State : online

## 7.3 Home Page

Home Access Point Statistics Admin  
 Dashboard About

On the Home Page, there are two submenus—Dashboard and About.

### 7.3.1 Dashboard Submenu

Home Access Point Statistics Admin  
 Dashboard About

The Dashboard is the initial screen that is displayed after logging in (shown below). The Dashboard displays GPS signal information.

#### GPS Signal Information

GPS Location (Latitude, Longitude) (33.014244,-117.094604)

Sat ID	Azimuth	Elevation	C/N <sub>0</sub>
7	313	53	36
6	61	23	33
20	177	9	31
19	109	27	38
3	81	34	35
13	69	76	41
28	216	15	33
23	120	55	38
16	40	19	34
8	282	31	35
10	282	36	40
5	324	2	19

If the AP has GPS connected to it, GPS values are shown.

**NOTE:** GPS verification MUST occur after completion of physical AP installation.

The columns on this screen are defined in the following table. The rows show the number of GPS satellites to which the AP receiver is currently locked. For proper GPS synchronization, there should be a minimum of **five** satellites.

**Table 6. Fields on the Access Point Screen**

Column Heading	Description
Sat ID	The Sat ID column provides the name of the GPS satellite to which the AP is locked or is tracking.
Azimuth	The Azimuth is the direction of a GPS satellite, measured clockwise around the observer's horizon from north. Azimuth and altitude or elevation are usually used together to give the direction of an object in the topocentric coordinate system.
Elevation	The elevation (sometimes called altitude) is the angle at which we see the satellite when we look up into the sky.
C/N <sub>0</sub>	Carrier to Noise (C/N <sub>0</sub> ) density ratio is the ratio of the carrier or signal power to the white-noise spectral density. For the AP GPS receiver to lock to the GPS satellite, the C/N <sub>0</sub> should be greater than 20 dB-Hz.

### 7.3.2 About Submenu

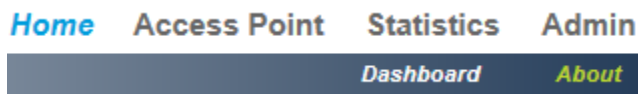

The About screen displays device specifications for the AP such as manufacturer, device type, MAC address of the AP, hardware, firmware, and software versions. There is nothing to configure on this screen, therefore the fields cannot be edited.

### Device Specification

<b>Manufacturer</b>	<b>On-Ramp Wireless Inc.</b>
<b>Device Type</b>	<b>Access Point</b>
<b>MAC Address</b>	<b>00:25:0F:03:02:32</b>
<b>Hardware Version</b>	<b>AP_MAIN : 510-0002-06 REV 1</b>
	<b>AP_RF : 510-0003-06 REV 1</b>
<b>Firmware Version</b>	<b>0x1079</b>
<b>Software Version</b>	<b>6.0.4</b>

### 7.4 Access Point Menu



The Access Point menu has the following submenus:

- TRN Config
- Field Config
- Backhaul Config
- Site Survey

### 7.4.1 TRN Config Submenu

The Total Reach Network (TRN) Configuration screen (shown below) displays network configuration parameters at the time the AP was deployed.

#### Total Reach Network Configuration

AP ID (in decimal [1-255])	<input type="text" value="0"/>
Deployment Region ID (in decimal [0-4228250625])	<input type="text" value="1"/>
System ID (in decimal [0-255])	<input type="text" value="15"/>
Channel (in decimal [1-40])	<input type="text" value="39"/>
Reuse Code (in decimal [0-255])	<input type="text" value="2"/>
Center Frequency (in MHz)	<input type="text" value="2477.62"/>
Broadcast Gold Code (in hex)	<input type="text" value="0x10FAE02"/>
Max Uplink PDUs (in decimal [4-512])	<input type="text" value="16"/> ▼
UL Overload Alarm Threshold (in dBm [0-31])	<input type="text" value="3"/>
Interference Alarm Threshold (in dBm [0-31])	<input type="text" value="10"/>
	<input type="button" value="Save"/>

The following table defines the fields on this screen. To edit these fields, click on the **Disable RF** button. After you make the changes, click on the **Save** button and then the **Enable RF** button.

**NOTE:** If you disable the RF, the AP is still connected to the Gateway.

**Table 7. Fields on the Total Reach Network Configuration Screen**

Field	Unit	Description
AP ID	Decimal	The identification number for the AP. Range is 1 – 255.
Deployment Region ID	Decimal	The identification number for the region where the AP is deployed. Number range is 0 – 4228250625.
System ID	Decimal	The System Identification Number. Range is 0 – 255.
Channel	Decimal	The channel on which the AP communicates. Range is 1 – 40.
Reuse Code	Decimal	Different Reuse Codes allow two APs to operate on the same Channel and System ID without interference. Range is 0 – 255.

Field	Unit	Description
Center Frequency	MHz	This field is not editable. The value for center frequency is determined from the setting for the Channel field.
Broadcast Gold Code	Hex	This field is not editable. The value for the broadcast gold code is determined from the information provided in the following fields: <ul style="list-style-type: none"><li>■ System ID</li><li>■ Channel</li><li>■ Reuse Code</li></ul>
Max Uplink PDUs	Decimal	The maximum number of PDUs allowed on the uplink. Range is 4 – 512. The default setting is 16.
UL Overload Alarm Threshold	dBm	This alarm triggers when the threshold for uplink capacity has been reached. Range is 0 – 31.
Interference Alarm Threshold	dBm	This alarm triggers when the threshold for interference on the uplink has been reached. Range is 0 – 31.

### 7.4.2 Field Config Submenu

The Field Configuration screen (shown below) displays configuration parameters that were set at the time the AP was deployed.

#### Field Configuration

Reset Broadcast Margin? (boolean)	<input checked="" type="radio"/> Yes <input type="radio"/> No
Force Scan Day (in yyyy/mm/dd GMT)	<input type="text"/>
RPMA Mode	Optimize Range <input type="button" value="v"/>
Online Duration Without GPS Fix (in seconds)	<input type="text" value="600"/>
<b>AP Transmit Parameters</b>	
Regulatory Domain (string)	FCC <input type="button" value="v"/>
AP Maximum EIRP Target (in dBm)	<input type="text" value="36"/>
Cavity Filter (boolean)	<input checked="" type="radio"/> Yes <input type="radio"/> No
AP Cable Loss (in dBm)	<input type="text" value="2"/>
AP Antenna Gain (in dBm)	<input type="text" value="9"/>
AP Maximum Transmit Power (in dBm)	<input type="text" value="31"/>
<b>Node Transmit Parameters</b>	
Node Maximum EIRP Target (in dBm)	<input type="text" value="24"/>
Node Cable Loss (in dBm)	<input type="text" value="0"/>
Node Antenna Gain (in dBm)	<input type="text" value="2"/>
Node Maximum Transmit Power (in dBm)	<input type="text" value="25"/>
<b>Power Control Parameters</b>	
Target Excess SNR (in dBm [0-31])	<input type="text" value="2"/>
Maximum BCH Power Control Target (in dBm [0-31])	<input type="text" value="10"/>
Minimum BCH Power Control Target (in dBm [0-31])	<input type="text" value="0"/>
<b>Link Budget</b>	
Uplink (in dBm)	<input type="text" value="167"/>
Downlink (in dBm)	<input type="text" value="169"/>
AP Maximum EIRP (Actual) (in dBm)	<input type="text" value="36"/>
Node Maximum EIRP (Actual) (in dBm)	<input type="text" value="24"/>
	<input type="button" value="Save"/>



The following table defines the fields on this screen. To edit these fields, click on the **Disable RF** button. After you make the changes, click on the **Save** button and then the **Enable RF** button.

**NOTE 1:** If you disable the RF, the AP is still connected to the Gateway.

**NOTE 2:** The maximum transmit power for the AP and the Node is based on the setting in the **Regulatory Domain** field.

**Table 8. Parameters on the Field Configuration Screen**

Field	Unit/Format	Description
Reset Broadcast Margin	Boolean	Resets the broadcast margin. The AP stays in this state until the next time it is rebooted.
Force Scan Day	yyyy/mm/dd	The date to perform a Force Scan.
RPMA Mode	N/A	Options are: <ul style="list-style-type: none"> <li>■ Optimize Capacity</li> <li>■ Optimize Range (Default)</li> </ul>
Online Duration Without GPS Fix	seconds	The length of time allowed for the AP not to have a GPS fix. The default is 600 seconds.
<b>AP Transmit Parameters</b> <i>(These parameters are based on regulatory domain, AP cable loss, and target excess SNR)</i>		
Regulatory Domain	string	The regulatory domain where the AP is deployed. The regulatory domain limits the maximum transmit power for the AP.
AP Maximum EIRP Target	dBm	The maximum EIRP output targeted for the AP.
Cavity Filter	Boolean	The default value is set according to country-specific regulatory requirements.
AP Cable Loss	dB	AP cable loss measured in dB.
AP Antenna Gain	dBi	This is the gain specified for the AP antenna installed.
AP Maximum Transmit Power	dBm	This field is not editable. The value is determined by the settings for the other AP Transmit Parameters.
<b>Node Transmit Parameters</b> <i>(These parameters are based on regulatory domain, Node cable loss, and target excess SNR)</i>		
Node Maximum EIRP Target	dBm	The maximum EIRP output targeted for the Node.
Node Cable Loss	dB	Default setting is 0 dB. Contact Ingenu (support@ingenu.com) prior to changing this parameter.
Node Antenna Gain	dBi	Default setting is 2 dBi. Contact Ingenu (support@ingenu.com) prior to changing this parameter.
Node Maximum Transmit Power	dBm	This field is not editable. The value is determined by the settings for Regulatory Domain and the other Node Transmit Parameters.

Field	Unit/Format	Description
<b>Power Control Parameters</b>		
Target Excess SNR	dB	Default setting is 1 dB. Contact Ingenu (support@ingenu.com) prior to changing this parameter.
Maximum BCH Power Control Target	dB	The default value is set according to country-specific regulatory requirements.
Minimum BCH Power Control Target	dB	The default value is set according to country-specific regulatory requirements.
<b>Link Budget</b>		
Uplink	dB	This field shows the total amount of link budget available for the uplink and is not editable.
Downlink	dB	This field shows the total amount of link budget available for the downlink and is not editable.
AP Maximum EIRP (Actual)	dBm	The actual maximum EIRP output for the AP.
Node Maximum EIRP (Actual)	dBm	The actual maximum EIRP output for the Node.

### 7.4.3 Backhaul Config Submenu

The Backhaul Configuration screen (shown below) displays configuration parameters that were set at the time the AP was deployed.

#### Backhaul Configuration

<b>Control Socket Mode</b>	<input type="radio"/> Server <input checked="" type="radio"/> Client
<b>Control Server Port Number</b>	<input type="text" value="2021"/>
<b>Total Reach Gateway Hostname/IP Address</b>	<input type="text" value="10.50.4.215"/>
<b>Total Reach Gateway Port Number</b>	<input type="text" value="5051"/>
<b>Enable HTTP Tunneling?</b>	<input checked="" type="radio"/> Yes <input type="radio"/> No
<b>Online Duration Without Backhaul Connection (in seconds)</b>	<input type="text" value="600"/>
<b>Keep-Alive Interval (in seconds)</b>	<input type="text" value="5"/>
<b>Message Tx Timeout (in seconds)</b>	<input type="text" value="5"/>
	<input type="button" value="Save"/>

The following table defines the fields on this screen. To edit these fields, click on the **Disable RF** button. After you make the changes, click on the **Save** button and then the **Enable RF** button.

**NOTE:** If you disable the RF, the AP is still connected to the Gateway.

**Table 9. Fields on the Backhaul Configuration Screen**

Field	Unit	Description
Control Socket Mode	N/A	Options for this field are as follows: <ul style="list-style-type: none"> <li>■ <b>Server:</b> When the AP is set to work in Server mode, it listens for a TCP connection with the Total Reach Gateway on port number 2021. See descriptions below for setting the following fields.</li> <li>■ <b>Client:</b> When the AP is set to work in Client mode, the AP requests service from the Total Reach Gateway. See the field descriptions below for setting the following fields.</li> </ul>
Control Server Port Number	N/A	The port number when the AP is set to Server mode. When the AP is in Server mode, this field should be set to 2021. The AP listens on port 2021 for a TCP connection with the Total Reach Gateway. Ensure that port 2021 is allowed on the firewall in your network.
Total Reach Gateway Hostname/IP Address	N/A	<ul style="list-style-type: none"> <li>■ For Server mode, this field is grayed out and not accessible.</li> <li>■ For Client mode, the Total Reach Gateway IP Address or Fully Qualified Domain Name (FQDN) should be entered here.</li> </ul>
Total Reach Gateway Port Number	N/A	<ul style="list-style-type: none"> <li>■ For Server mode, this field is grayed out and not accessible.</li> <li>■ For Client mode, this field should be set to 5051. Ensure that port number 5051 is allowed on the network firewall.</li> </ul>
Enable HTTP Tunneling?	N/A	Options for this field are: Yes or No. When <b>Yes</b> is selected, the following option is available: <b>Use HTTP Tunneling Proxy?</b> The options for this parameter are also Yes or No. When <b>Yes</b> is selected, the following parameters are available to configure: <ul style="list-style-type: none"> <li>■ <b>HTTP Proxy IP Address:</b> The IP address of the http proxy server to use</li> <li>■ <b>HTTP Proxy Port Number:</b> The port number of the http proxy server to use</li> <li>■ <b>HTTP Proxy User Name:</b> This is optional.</li> <li>■ <b>HTTP Proxy Password:</b> This is optional.</li> </ul>
Online Duration Without Backhaul Connection	seconds	The length of time allowed for the AP not to have a GPS fix. The default is 600 seconds.
Keep-Alive Interval	seconds	The number of seconds allowed for the interval where the AP checks the link to the network to determine whether the link is still "alive" or broken.
Message Tx Timeout	seconds	The number of seconds allowed before the AP times out and stops trying to transmit a message.

### 7.4.4 Site Survey Submenu

The Site Survey screen (shown below) allows you to run a site survey, select the appropriate channel on which the AP operates, and determine the number of frames per channel. It also allows you to download survey results (sorted by RSSI or channel) and download diagnostic results.

#### Site Survey



## 7.5 Statistics Menu

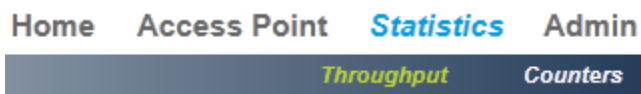

The Statistics menu has the following submenus:

- Throughput
- Counters

### 7.5.1 Throughput Submenu

The Throughput screen (shown below) provides a graph of uplink throughput in bits per second.

**Total Reach Network Link Statistics**

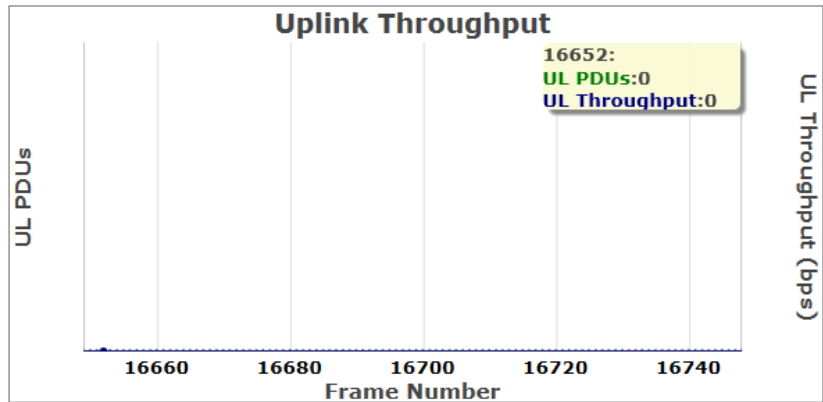

**7.5.2 Counters Submenu**

The AP Counters screen (shown below) provides various counters for uplink and downlink.

**AP Counters**

Counters	Value
Missed UL Count	0
Uplink Pdu Count	0
Downlink Pdu Count	0
Uplink Control Sdu Count	0
Downlink Control Sdu Count	0
Downlink Acked Control Sdu Count	0
Uplink Data Sdu Count	0
Uplink Stream1 Data Sdu Count	0
Uplink Stream2 Data Sdu Count	0
Downlink Data Sdu Count	0
Downlink Acked Data Sdu Count	0

**7.6 Admin Menu**

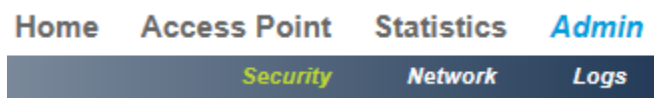

The Admin menu has the following submenus:

- Security
- Network
- Logs

### 7.6.1 Security Submenu

The following Security Configuration screen provides information related to system services, administrator password, and SNMP configuration.

#### Security Configuration

System Services	
Preferences:	<input type="checkbox"/> Disable Telnet login? <span style="float: right;">Save</span> <input checked="" type="checkbox"/> Enable SSL for Sockets?
Change 'admin' Password	
Old Password:	<input type="password" value="*****"/> <span style="float: right;">Save</span>
New Password:	<input type="password" value="*****"/> <span style="float: right; background-color: green; color: white; padding: 2px;">Very Strong</span>
Re-type to confirm:	<input type="password" value="*****"/>
SNMP Configuration	
Version:	<input checked="" type="checkbox"/> Enable SNMPv2c? <span style="float: right;">Save</span> <input checked="" type="checkbox"/> Enable SNMPv3?
Transport:	<input checked="" type="checkbox"/> Enable SNMP over UDP? Port: <input type="text" value="161"/> <input checked="" type="checkbox"/> Enable SNMP over TCP? Port: <input type="text" value="161"/>
Community:	<input type="text" value="public"/>
Write Community:	<input type="text" value="private"/>
Minimum Security Level:	<input type="text" value="Auth Priv"/> ▼
User Name:	<input type="text" value="SnmpAdmin"/>
Authentication Protocol:	<input type="text" value="MD5"/> ▼
Authentication Password:	<input type="password" value="*****"/>
Privacy Protocol:	<input type="text" value="DES"/> ▼
Privacy Password:	<input type="password" value="*****"/>

The following table defines the fields on this screen.

**Table 10. Parameters on the Security Configuration Screen**

Field	Description
<b>System Services</b>	
Preferences	Options are: <ul style="list-style-type: none"> <li>■ Disable Tenet login?</li> <li>■ Enable SSL for Sockets?</li> </ul>
<b>Change 'admin' Password</b>	
Old Password	To change the password, you must first enter the old password.
New Password	Enter the new password.
Re-type to Confirm	Re-type the new password to confirm the change.
<b>SNMP Configuration</b>	
Version	Options are: <ul style="list-style-type: none"> <li>■ <b>Enable SNMPv2c?</b> If this is selected, the following options are available: <ul style="list-style-type: none"> <li><input type="checkbox"/> Transport</li> <li><input type="checkbox"/> Community</li> <li><input type="checkbox"/> Write Community</li> </ul> These options are defined below. </li> <li>■ <b>Enable SNMPv3?</b> If this is selected, the following options, in addition to those listed above for SNMPv2c, are available: <ul style="list-style-type: none"> <li><input type="checkbox"/> Minimum Security Level</li> <li><input type="checkbox"/> User Name</li> <li><input type="checkbox"/> Authentication Protocol</li> <li><input type="checkbox"/> Authentication Password</li> <li><input type="checkbox"/> Privacy Protocol</li> <li><input type="checkbox"/> Privacy Password</li> </ul> These options are defined below. </li> </ul>
Transport	Options are: <ul style="list-style-type: none"> <li>■ <b>Enable SNMP over UDP?</b> If this is selected, enter the port number.</li> <li>■ <b>Enable SNMP over TCP?</b> If this is selected, enter the port number.</li> </ul>
Community	Specifies SNMPv2c community string (password) for read-only access to the full tree of SNMP managed objects on the AP. Default value is <b>Public</b> .
Write Community	Specifies SNMPv2c community string (password) for read-write access to the full tree of SNMP managed objects. The default value is <b>Private</b> .

Field	Description
Minimum Security Level	Specifies SNMPv3 minimum security level. From the dropdown menu, the options are: <ul style="list-style-type: none"> <li>■ <b>No Auth No Priv</b> Allows unauthenticated requests.</li> <li>■ <b>Auth No Priv</b> Allows authenticated requests without privacy or encryption.</li> <li>■ <b>Auth Priv</b> Allows authenticated requests with privacy to enforce use of encryption.</li> </ul>
User Name	Specifies an SNMPv3 user that will be allowed read-only or read-write access to the full tree of SNMP-managed objects on the AP.
Authentication Protocol	Specifies the hash algorithm to use for authentication of SNMPv3 requests. From the dropdown menu, the options are: <ul style="list-style-type: none"> <li>■ <b>MD5</b>: The cryptographic hash function as specified by IETF RFC 1321.</li> <li>■ <b>SHA</b>: The Secure Hash Algorithm function as specified by NIST standard FIPS 180-4.</li> </ul>
Authentication Password	Specifies the passphrase used for authentication of SNMPv3 requests.
Privacy Protocol	Specifies the privacy protocols to use for encryption of SNMPv3 requests. From the dropdown menu, the options are: <ul style="list-style-type: none"> <li>■ <b>DES</b>: The Data Encryption Standard algorithm for encryption as specified by NIST standard FIPS 46-3.</li> <li>■ <b>AES</b>: The Advanced Encryption Standard algorithm for encryption as specified by NIST standard FIPS PUB 197.</li> </ul>
Privacy Password	Specifies the passphrase used for encryption of SNMPv3 requests.

**NOTE:** To increase network security, it is recommended that you check the boxes to **"Disable Telnet login"** and **"Enable SSL for Sockets."** It is also recommended that you change the default passwords for the following fields:

- Admin Password
- Community
- Write Community
- Authentication Password
- Privacy Password



## 7.6.2 Network Submenu

The Network Configuration screen (shown below) allows you to change the AP IP address, netmask, and default router as well as other network configuration parameters such as Ethernet speed and MTU, duplex mode, and DNS and NTP servers.

### Network Configuration

The following table defines the fields on this screen.

**Table 11. Fields on the Network Configuration Screen**

Field	Description
IPv4 Settings	<p>Currently the AP only supports two IP settings for TCP/IP Versions:</p> <ul style="list-style-type: none"> <li>■ <b>Automatic (DHCP):</b> This setting is used to request a dynamic IP address from a local DHCP server.</li> <li>■ <b>Manual (Static IP):</b> This setting is used for configuring a fixed IP address.</li> </ul>
Wired Interfaces	<p>The AP uses IP aliasing to prevent it from being inaccessible when changing IP address. The AP can be accessed using an old IP address if incorrect IP address settings are entered accidentally.</p> <ul style="list-style-type: none"> <li>■ <b>Primary (etho):</b> This interface is always enabled.</li> <li>■ <b>Secondary (etho:0):</b> This interface is enabled whenever primary interface settings are modified.</li> </ul> <p><b>NOTES:</b></p> <ul style="list-style-type: none"> <li>■ If the primary interface settings are modified, the current values roll over to secondary and the secondary interface is enabled on reboot.</li> <li>■ If the AP is rebooted with incorrect primary interface settings, it can still be accessed using the old settings via the secondary interface.</li> <li>■ If the primary interface settings are correct, then the secondary interface may be disabled to re-use its IP settings elsewhere to prevent IP address collisions.</li> </ul>

Field	Description
IP Address	IP address of the AP (e.g., default is 192.168.1.1)
Netmask	The default is 255.255.255.0.
Default Router	The default is 192.168.1.254.
Ethernet Speed	The speed at which data travels over the Ethernet connection. Setting options are: Auto, 10 Mbit, and 100 Mbit. The default setting is "Auto" which monitors the connection and displays the current speed.
Duplex Mode	Setting options are: Auto, Half-Duplex, and Full-Duplex. The default setting is "Auto" which displays the current duplex mode.
Ethernet MTU	The largest frame size that can be transmitted over the network. The default setting is 1500 bytes. Messages longer than the Ethernet MTU indicated in this field must be divided into smaller frames.
DNS Servers	The IP address of the DNS server can be set in this text field. Multiple DNS servers can be configured for an AP by separating the IP addresses of each DNS server with a comma when entering them into the text field. The following DNS server addresses are the defaults: <ul style="list-style-type: none"> <li>■ 208.67.222.222</li> <li>■ 208.67.220.220</li> <li>■ 8.8.8.8</li> <li>■ 8.8.4.4</li> </ul>
NTP Servers	The AP should be configured with valid NTP servers for correct time synchronization. If the AP is not configured, it may have problems connecting to the Total Reach Gateway using SSL. The following NTP server addresses are the defaults: <ul style="list-style-type: none"> <li>■ nist1-nj.ustiming.org</li> <li>■ nist1-atl.ustiming.org</li> <li>■ nist1-la.ustiming.org</li> <li>■ nist1-sj.ustiming.org</li> <li>■ nist1-lv.ustiming.org</li> <li>■ time.nist.gov</li> </ul> As with DNS server configuration, multiple NTP server IP addresses can be entered into this text field separated with commas.

### Procedure for Changing IP Address Settings

The AP uses IP aliasing to prevent it from being inaccessible when changing the IP address. This feature allows the AP to be accessible in the event that an incorrect IP address is inadvertently entered. In this case, the old IP address would be used.

19. Change the IP address settings on Primary. The old Primary settings roll over to Secondary.
20. Click on the **Save** button and you are prompted to reboot the AP. An AP "reboot" is required in most cases.
21. After the AP is rebooted, verify that the primary address settings are good.
22. If the primary settings are good, optionally disable Secondary to avoid any IP address collisions.
23. If the primary settings are incorrect:

- a. Select "**Skip rollover to Secondary?**"
- b. Change the primary settings
- c. Go to step 2.

## 7.6.3 Logs Submenu

The Logs screen (shown below) allows you to download AP logs. By clicking on a dropdown menu, you can choose from five log levels that provide various levels of detail:

- **Critical:** This setting shows only critical log information.
- **Error:** This setting shows error and critical log information.
- **Warning:** This setting shows warning, error, and critical log information.
- **Informational:** This setting shows informational, warning, error, and critical log information.
- **Debug:** This setting shows debug, informational, warning, error, and critical log information.

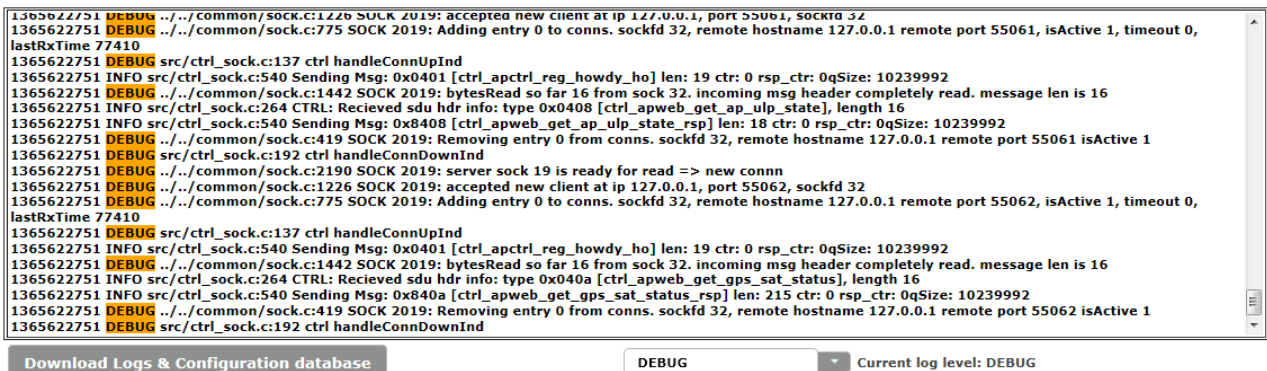

```

1365622751 DEBUG ../../common/sock.c:1226 SOCK 2019: accepted new client at ip 127.0.0.1, port 55061, sockfd 32
1365622751 DEBUG ../../common/sock.c:775 SOCK 2019: Adding entry 0 to conns. sockfd 32, remote hostname 127.0.0.1 remote port 55061, isActive 1, timeout 0, lastRxTime 77410
1365622751 DEBUG src/ctrl_sock.c:137 ctrl handleConnUpInd
1365622751 INFO src/ctrl_sock.c:540 Sending Msg: 0x0401 [ctrl_apctrl_reg_howdy_ho] len: 19 ctr: 0 rsp_ctr: 0qSize: 10239992
1365622751 DEBUG ../../common/sock.c:1442 SOCK 2019: bytesRead so far 16 from sock 32. incoming msg header completely read. message len is 16
1365622751 INFO src/ctrl_sock.c:264 CTRL: Recieved sdu hdr info: type 0x0408 [ctrl_apweb_get_ap_ulp_state], length 16
1365622751 INFO src/ctrl_sock.c:540 Sending Msg: 0x8408 [ctrl_apweb_get_ap_ulp_state_rsp] len: 18 ctr: 0 rsp_ctr: 0qSize: 10239992
1365622751 DEBUG ../../common/sock.c:419 SOCK 2019: Removing entry 0 from conns. sockfd 32, remote hostname 127.0.0.1 remote port 55061 isActive 1
1365622751 DEBUG src/ctrl_sock.c:192 ctrl handleConnDownInd
1365622751 DEBUG ../../common/sock.c:2190 SOCK 2019: server sock 19 is ready for read => new connn
1365622751 DEBUG ../../common/sock.c:1226 SOCK 2019: accepted new client at ip 127.0.0.1, port 55062, sockfd 32
1365622751 DEBUG ../../common/sock.c:775 SOCK 2019: Adding entry 0 to conns. sockfd 32, remote hostname 127.0.0.1 remote port 55062, isActive 1, timeout 0, lastRxTime 77410
1365622751 DEBUG src/ctrl_sock.c:137 ctrl handleConnUpInd
1365622751 INFO src/ctrl_sock.c:540 Sending Msg: 0x0401 [ctrl_apctrl_reg_howdy_ho] len: 19 ctr: 0 rsp_ctr: 0qSize: 10239992
1365622751 DEBUG ../../common/sock.c:1442 SOCK 2019: bytesRead so far 16 from sock 32. incoming msg header completely read. message len is 16
1365622751 INFO src/ctrl_sock.c:264 CTRL: Recieved sdu hdr info: type 0x040a [ctrl_apweb_get_gps_sat_status], length 16
1365622751 INFO src/ctrl_sock.c:540 Sending Msg: 0x840a [ctrl_apweb_get_gps_sat_status_rsp] len: 215 ctr: 0 rsp_ctr: 0qSize: 10239992
1365622751 DEBUG ../../common/sock.c:419 SOCK 2019: Removing entry 0 from conns. sockfd 32, remote hostname 127.0.0.1 remote port 55062 isActive 1
1365622751 DEBUG src/ctrl_sock.c:192 ctrl handleConnDownInd

```

Download Logs & Configuration database      DEBUG      Current log level: DEBUG

Only the last 100 log entries are shown on this screen. To see additional log entries, you can download the logs and configuration database by clicking on the "**Download Logs & Configuration database**" button. When you click on this button, a pop-up dialog box appears asking whether you would like to open or save the "ap.tgz" file. The compressed tar file contains two folders: "onramp" and "tmp." The file structure is shown below.

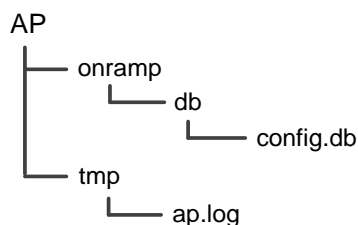

The "config.db" file is the configuration file for the SQLite database used in the AP and the "ap.log" file is the log file for the AP.

## 8 AP Communication Troubleshooting

Before you leave the installation site, contact your network operations center (NOC) to verify that the AP is online and successfully communicating. If remote communication with the AP is not possible, perform the following steps:

24. Manually configure the following on a laptop:
  - ❑ The IP address of the Ethernet port
  - ❑ Netmask setting
  - ❑ The Default Router setting
25. Unplug the backhaul connector from the data port of the PoE and connect the laptop to that port.
26. Verify that you can locally log in to the AP as described in section 7.2.
  - ❑ If you can successfully log in, further testing of the backhaul and its configuration is needed.
  - ❑ If you cannot log in, check the IP setting of your laptop.
  - ❑ If no problems are found, refer to the [Chapter 9: Troubleshooting Guide](#).

The following figure illustrates a method for detailed on-site debugging of an AP installation. The Ethernet hub allows the user to “sniff” Ethernet traffic between the backhaul port and the AP to troubleshoot and resolve any issues.

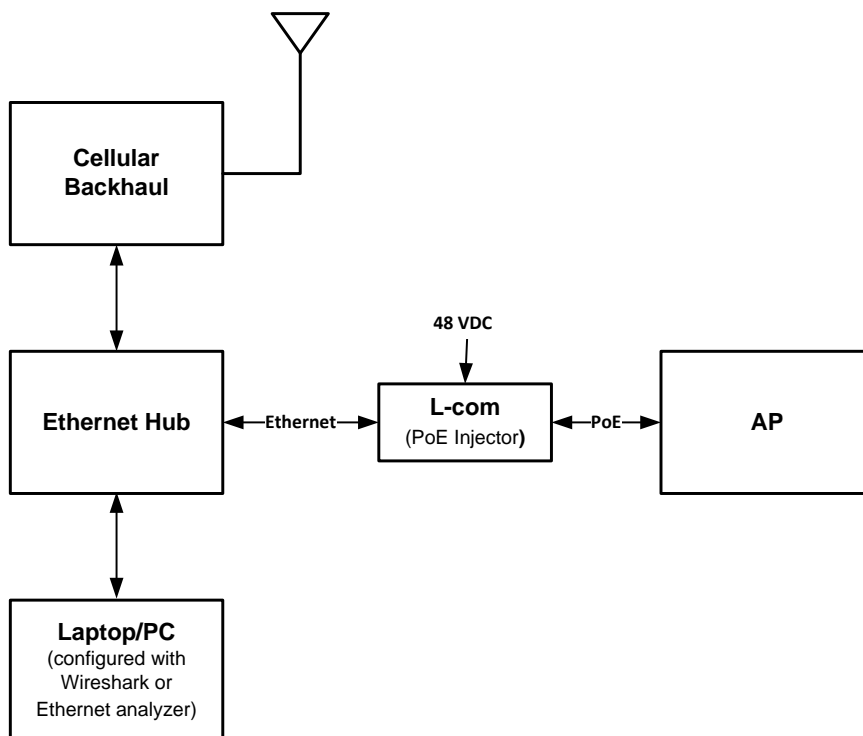

Figure 17. Sample Method for On-site Debugging of an AP Installation

# 9 Troubleshooting Guidelines

Use the following table to help troubleshoot a problem.

**Table 12. Troubleshooting Guide**

Problem	Action
<p>AP does not power up  (Status LED is not illuminated or flashing)</p>	<ul style="list-style-type: none"> <li>■ When the AP is powered, the Status LED illuminates or flashes. If not, check the Ethernet cable and connector for damage.</li> <li>■ Verify that the PoE injector is connected properly (i.e., the AP is connected to Data + Power side).</li> <li>■ Verify that a nominal voltage of 48 VDC is present at the power connector of the PoE.</li> <li>■ Verify that the PoE injector is not defective by substituting another known working PoE.</li> <li>■ Verify that the backhaul cable from the Data connector on the PoE injector is connected to a router, backhaul device, or laptop that is powered up. Connectivity is not required but the port must be active.</li> <li>■ Contact On-Ramp for assistance</li> </ul>
<p>AP does not acquire GPS</p>	<ul style="list-style-type: none"> <li>■ Verify that the GPS antenna cable and the AP antenna cable are connected and have not been swapped. If the connectors were swapped, it is necessary to power cycle the AP.</li> <li>■ Disconnect both ends of the GPS. Verify continuity and that the cable is not shorted.</li> <li>■ Verify the GPS antenna is not defective by substituting a known working GPS antenna.</li> <li>■ Contact On-Ramp for assistance.</li> </ul>
<p>Link problem</p>	<ul style="list-style-type: none"> <li>■ Is the Link LED blinking? If not, check the Ethernet cable and connector for damage.</li> <li>■ Verify that the PoE injector is connected to the WAN.</li> <li>■ Connect a properly configured laptop to the data port on the PoE, as described in chapter 8, and attempt to log into the AP. If successful, troubleshoot the backhaul.</li> <li>■ Contact Ingenu for assistance.</li> </ul>

## 10 Preventive Maintenance

---

The recommended preventive maintenance schedule for the AP is shown in the following table. For additional assistance, contact Ingenu Customer Support at (858) 592-6008 or [support@ingenu.com](mailto:support@ingenu.com).

**NOTE:** Do NOT open the AP enclosure. Doing so voids the product warranty.

**Table 13. Preventive Maintenance Schedule**

Task	Frequency
1. Verify that all connections are tight and secure.	Annually
2. Verify that there is no visible damage to any wires or cables.	Annually
3. Ensure that the exposed connectors are properly sealed against weather conditions.	Annually
4. Verify that the AP door screws are tight and that the warranty seal is in place	Annually
5. Verify that all required grounds are connected and tight.	Annually
6. Verify that all mounts and bracket are securely attached.	Annually

# Appendix A Site Survey Worksheet

---

Site Survey	Required Information	✓ Completed
Site name		
AP ID		
Site street address or other location information		
Site access information		
Landlord contact information		
Specific landlord requirements (Attach another sheet if there is significant information)		
Latitude		
Longitude		
Site type (building, tower, pole, or other)		
Height of existing structure		
AP equipment mounting location		
AP antenna mounting location and height		
Antenna line length required		
GPS mounting location		
GPS line length		
AP power type, commercial power, or solar solution		
Distance to commercial power, if available		
Photos of site including antennal location, AP location, and overall site (Attach all photos to this worksheet.)	See attachments.	
Other site-specific information		

# Appendix B AP Installation Configuration Worksheet

---

AP Installation Configuration	Required information	✓ Completed
Site name		
AP Name		
AP ID		
Deployment Region ID		
AP physical configuration ( <i>Outdoor, indoor, standalone, in cabinet, or other</i> )		
Power source (120/240 VAC, 48 VDC, or solar)		
AP antenna manufacturer		
AP antenna model		
AP antenna gain		
AP antenna downtilt		
AP antenna cable type		
AP antenna cable length		
AP antenna cable loss		
GPS antenna model		
GPS cable type		
GPS cable length		
Backhaul type		
Backhaul equipment location		
Backhaul configuration information		
Power over Ethernet (PoE) injector location		
Ethernet cable type		
Ethernet cable length		
AP Static or DHCP IP address (Static or Dynamic?)		
AP IP address	(Default: 192.168.1.1)	
Netmask setting	(Default: 255.255.255.0)	



AP Installation Configuration	Required information	✓ Completed
Default router	(Default: 192.168.1.254)	
DNS servers		
NTP servers		
AP Socket mode, Server or Client	For System Release 2.1, the Client mode is always used.	
Server port number	This is not used for System Release 2.1.	
TRN Gateway IP address		
TRN Gateway port number	(Default: 5051)	
SNMP server address		
Channel assignment		
Reuse Code		

## Appendix C Basic AP Specifications

---

The AP is equivalent to a base station. The following table provides the basic specification information for the AP. For detailed product specifications, refer to the *Access Point Product Specification (014-0030-00)*.

<b>Size</b>	Inches: 9.1"H x 8.1"W x 4.5"D Millimeters: 232mm H x 202mm W x 111mm D
<b>Maximum Weight</b>	Pounds: 9.6 Kilograms: 4.35
<b>Operating Environment</b>	Outdoors or indoors
<b>Enclosure</b>	IP66
<b>Operating Temperature Range</b>	-40°C to +80°C
<b>Power Source Voltage Range (PoE)</b>	38 – 72 VDC, Nominal 48 VDC Power over Ethernet
<b>Current Consumption</b>	0.35A maximum @ 48 VDC, .29A typical
<b>Power Dissipation</b>	17 Watts (maximum)
<b>Antenna Connector</b>	Type N, female
<b>GPS Connector</b>	Type N, female
<b>GPS Antenna Type</b>	Powered
<b>Data and Power Connector</b>	RJ45
<b>GPS Power</b>	3.3 VDC @ 50 mA maximum over coaxial cable

# Appendix D Base Station Configuration

**Table 14. Ingenu TRN Base Station Configuration Options**

Base Station Option	Description	Applications	Required Ingenu Hardware	Additional Items Required
TRN-1011 Base Station	<ul style="list-style-type: none"> <li>■ Outdoor base station</li> <li>■ 120/240 VAC powered system with 8 hours of battery backup</li> <li>■ AP is located in the equipment cabinet along with a 3G modem and battery backup</li> </ul>	<p>Outdoor locations with AC power requiring 3G modem backhaul.</p> <p>For example:</p> <ul style="list-style-type: none"> <li>■ Communication sites</li> <li>■ Transmission Towers</li> <li>■ Wood distribution poles</li> <li>■ Outdoor Wall mount</li> </ul>	<ul style="list-style-type: none"> <li>■ Access Point</li> <li>■ Outdoor equipment cabinet powered by 120/240 VAC and contains:               <ul style="list-style-type: none"> <li>□ One Integrated GPS antenna</li> <li>□ One 3G modem</li> <li>□ Two integrated 3G modem antennas</li> <li>□ Antenna surge suppressor</li> <li>□ Backup battery</li> <li>□ Alarm monitor</li> </ul> </li> <li>■ 9 dBi AP antenna</li> </ul>	<ul style="list-style-type: none"> <li>■ Customer-supplied 3G Digi modem (U805)</li> <li>■ Site-specific cable for the AP antenna</li> <li>■ Site-specific installation hardware</li> </ul>
TRN-1021 Base Station	<ul style="list-style-type: none"> <li>■ Outdoor base station</li> <li>■ Solar powered</li> <li>■ Access Point is located outdoors</li> <li>■ 3G modems and backup batteries are located inside the equipment cabinet</li> </ul>	<p>Outdoor locations without power requiring 3G modem backhaul.</p> <p>For example:</p> <ul style="list-style-type: none"> <li>■ Transmission towers</li> <li>■ Sites without power</li> </ul>	<ul style="list-style-type: none"> <li>■ Access Point</li> <li>■ Outdoor equipment cabinet powered by solar system and contains:               <ul style="list-style-type: none"> <li>□ 3G modem</li> <li>□ Two integrated 3G modem antennas</li> <li>□ Antenna surge suppressor</li> <li>□ Two backup batteries</li> <li>□ Alarm monitor</li> </ul> </li> <li>■ GPS antenna</li> <li>■ 9 dBi AP antenna</li> <li>■ Pipe mounting hardware for a 4-inch OD pipe</li> <li>■ All cables (with the exception of the cable for the AP antenna)</li> </ul>	<ul style="list-style-type: none"> <li>■ Customer-supplied 3G Digi modem (U805)</li> <li>■ Site-specific cable for the AP antenna</li> <li>■ Customer-supplied 4-inch OD pipe for mounting equipment</li> <li>■ Site-specific installation hardware</li> </ul>

Base Station Option	Description	Applications	Required Ingenu Hardware	Additional Items Required
TRN-1031 Base Station	<ul style="list-style-type: none"> <li>■ Indoor rack-mounted base station</li> <li>■ Contains a 19-inch rack 3RU shelf</li> <li>■ AP is mounted on the shelf</li> <li>■ Powered by either 120/240 VAC or 48 VDC</li> </ul>	Indoor rack mount environment with access to power and corporate IP network. For example: <ul style="list-style-type: none"> <li>■ Communication site shelters</li> <li>■ IT equipment rooms</li> <li>■ Substation equipment rooms</li> </ul>	<ul style="list-style-type: none"> <li>■ Access Point</li> <li>■ A 19-inch rack 3RU shelf including:                             <ul style="list-style-type: none"> <li>□ 120/240 VAC power supply</li> <li>□ 48 VDC terminal strip/cable</li> </ul> </li> <li>■ Antenna surge suppressor</li> <li>■ GPS antenna</li> <li>■ 9 dBi AP antenna</li> </ul>	<ul style="list-style-type: none"> <li>■ Site-specific cables for the AP antenna and the GPS antenna</li> <li>■ Site-specific installation hardware</li> </ul>
TRN-1032 Base Station	<ul style="list-style-type: none"> <li>■ Rack-mounted base station</li> <li>■ Contains a 19-inch rack 3RU shelf</li> <li>■ Powered by either 120/240 VAC or 48 VDC</li> <li>■ AP is mounted outdoors</li> </ul>	Secure locations with indoor rack mount environment, power and access to corporate IP network. For example: <ul style="list-style-type: none"> <li>■ Rooftop outdoor AP</li> <li>■ Tower-mounted AP</li> <li>■ Wood pole-mounted AP</li> </ul>	<ul style="list-style-type: none"> <li>■ Access Point</li> <li>■ A 19-inch rack 3RU shelf including:                             <ul style="list-style-type: none"> <li>□ 120/240 VAC power supply</li> <li>□ 48 VDC terminal strip/cable</li> </ul> </li> <li>■ Antenna surge suppressor</li> <li>■ GPS antenna</li> <li>■ 9 dBi AP antenna</li> </ul>	<ul style="list-style-type: none"> <li>■ Site-specific cables for the AP antenna and the GPS antenna</li> <li>■ Site-specific Ethernet cable between the shelf and the AP</li> <li>■ Site-specific installation hardware</li> <li>■ AP pipe mount (optional)</li> </ul>
<p><b>NOTE:</b> All TRN base stations require an external AP antenna.</p>				

For information about any of these packages, contact your Ingenu representative at [support@ingenu.com](mailto:support@ingenu.com).

## Appendix E Abbreviations and Terms

Abbreviation/Term	Definition
AP	Access Point. The RPMA network component geographically deployed over a territory.
CIMA	Critical Infrastructure Monitoring Application. The network component that passes data from the Gateway to the associated upstream databases. This product name is transitioning to On-Ramp Total View.
DL	Downlink
DNS	Domain Name System
DTF	Distance to Fault
DVM	Digital Voltmeter
EIRP	Equivalent Isotropically Radiated Power
EMS	Element Management System. The network component that provides a concise view of controls and alarms on the On-Ramp Total Reach network.
ETSI	European Telecommunications Standards Institute
FCC	Federal Communications Commission
FIPS	Federal Information Processing Standards
GPS	Global Positioning System
GW	Gateway
IC	Industry Canada
IETF	Internet Engineering Task Force
IP	Internet Protocol
IPsec	Internet Protocol Security
NID	Node ID
NIST	National Institute of Standards and Technology
Node	The wireless module developed by Ingenu that integrates with OEM sensors and communicates sensor data to an Access Point. Also, the generic term used interchangeably with eNode or microNode.
NTP	Network Time Protocol
On-Ramp Total View	The network component that passes data from the Gateway to the associated upstream databases. Formerly known as CIMA.
On-Ramp Total Reach	The Ingenu's' proprietary wireless communication technology and network.
PV	Photovoltaic
RF	Radio Frequency
RFC	Request for Comments
RFID	Radio Frequency Identification
RSSI	Receive Signal Strength Indicator

Abbreviation/Term	Definition
SSL	Secure Socket Layer
STP	Shielded Twisted Pair
TCP	Transmission Control Protocol
TRN	Total Reach Network
UL	Uplink
UTP	Unshielded Twisted Pair

DRAFT

---

DRAFT