



ES 2100 / ES 2200 / IS 3200 / BR 4200

Installation Manual

800-356-2671 | **Accutech** | www.accutech-ics.com
Version 2.37 July 2008

IMPORTANT FCC & DOC INFORMATION

Note: This equipment has been tested and found to comply with the limits for a Class B digital device, pursuant to Part 15 of the FCC Rules. These limits are designed to provide reasonable protection against harmful interference in a residential installation. This equipment generates, uses, and can radiate radio frequency energy and, if not installed and used in accordance with the instructions, may cause harmful interference to radio communications. However, there is no guarantee that interference will not occur in a particular installation. If this equipment does cause harmful interference to radio or television reception, which can be determined by turning the equipment off and on, the user is encouraged to try to correct the interference by one or more of the following measures:

- Reorient or relocate the receiving antenna.
- Increase the separation between the equipment and receiver.
- Connect the equipment into an output on a circuit different from that to which the receiver is connected.
- Consult the dealer or an experienced radio/TV technician for help.

Canadian D.O.C. Statement

This digital apparatus does not exceed the Class B limits for radio noise emissions from digital apparatus as set out in the radio interference regulations of the Canadian Department of Communications.

Le present appareil numerique n'emet pas de bruits radioelectriques depassant les limites appliquees aux appareils numeriques de Class B prescrites dans le reglement sur le brouillage radioelectrique dicte par le ministere des Communications du Canada.

FCC ID/DOC for the Zone/Auxiliary Receiver:

FCC ID: JM7-IGWT-660076
Canada IC: 2683A-660076

This device complies with Part 15 of the FCC rules. Operation is subject to the following two conditions: (1) This device may not cause harmful interference, and (2) this device must accept any interference received, including interference that may cause undesired operation.

FCC ID/DOC for the ES Sensor:

FCC ID: JM7-IGWT-662002
Canada IC: 2683A-662002

This device complies with Part 15 of the FCC rules. Operation is subject to the following two conditions: (1) This device may not cause harmful interference, and (2) this device must accept any interference received, including interference that may cause undesired operation.

FCC ID/DOC for the ES Controller:

FCC ID: JM7-ITYS-700035
Canada 2683 102 312

This device complies with Part 15 of the FCC rules. Operation is subject to the following two conditions: (1) This device may not cause harmful interference, and (2) this device must accept any interference received, including interference that may cause undesired operation.

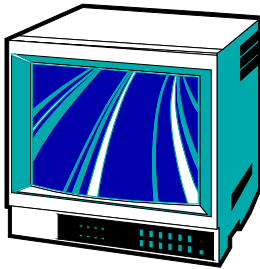
FCC ID/DOC for the S-TAD:

FCC ID: JM7-IGWT-662008
Canada IC: 2683A-662008

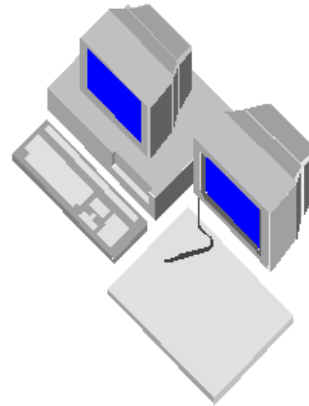
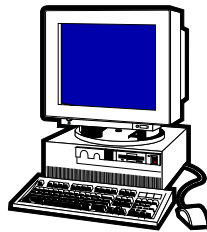
This device complies with Part 15 of the FCC rules. Operation is subject to the following two conditions: (1) This device may not cause harmful interference, and (2) this device must accept any interference received, including interference that may cause undesired operation.

IMPORTANT:

Keep all Televisions, Computers, X-ray equipment, etc. **at least 10 feet** away from the ES Receiver. This includes equipment located on the other side of walls and doors.



Picture the area around the monitored zone as a big globe with the receive antenna as the center. Keep all sources of interference outside this globe.

**IMPORTANT NOTICE:**

Do not store ES Sensor(s) within 3 feet of ANY of the sources of electrical noise listed on this page. These sources can reduce sensor activation. This activation can lead to possible undesirable responses from the system.

Common Sources of Interference Include:

- Television Sets
- Computer Monitors
- Medical Monitoring Equipment
- Electric Motors
- Electrical Distribution Panels and Transformers
- Fluorescent Lighting
- Some Electronic Washers and Dryers
- X-ray and other Imaging Equipment
- Unshielded Computer Cables

FOR UL LISTED SYSTEMS:

| MODEL | VOLTAGE, V | FREQUENCY | CURRENT |
|----------------|---------------------------|-------------------------|--|
| ESI, ESR, ES | 120 V | 50-60 HZ | 1 A |
| ESRI, ESRR | 12 | DC | 50 mA |
| TW | 24 | DC (RMS) | 150 mA |
| FPI, FPIB | 12 | DC | 120 mA |
| SAP | 12 | DC | 300 mA |
| GDP | 12 | DC | 500 mA |
| ED | 12 | DC | 100 mA |
| ADD | 12 | DC | 100 mA |
| PS51, PS68 | PRI – 120 V SEC – 12 V | PRI – 60 HZ SEC - DC | PS51 = 5.1 A PS68 = 6.8 A |
| MX, MXB | 12 | DC | 500 mA |
| LT, SB, BR, CB | 3.0 | DC | Standby off = 1.5 uA Standby on = 5 uA Transmit (BR) = 1.6 mA Transmit activated (all) = 3 mA |
| TAD, PTAD | 9 | DC | NSC = 20 mA, Transmit = (2s)80 mA |
| CL-8A | 12 | DC | NSC = 15 mA, Alarm = 55 mA |

| MODEL | OPERATION |
|------------|---|
| ESI, ESR | Controller coordinates and controls all of the devices and functions. |
| ES | Controller PCB |
| ESRI, ESRR | Receiver picks up signal from an activated Tag and relays it to the Controller (ESI) and the Multiplexer (MX). |
| TW | Transmit wand antenna generates a Tag-activating signal near a monitored zone. |
| FPI, FPIB | Fire Panel Interface ensures that in the event of a fire alarm, the Lock and Elevator Deactivator will disengage. |
| SAP | Staff Alert Panel notifies staff when an activated Tag enters a monitored zone via a piezo and LEDs. |
| GDP | Graphic Display Panel provides staff with a visual representation of the floor being monitored and notifies staff when an activated Tag enters a monitored zone via a piezo and LEDs. |
| ED | Elevator Deactivator prevents monitored residents from using the elevator. |
| ADD | Automatic Door Deactivator prevents monitored residents from using the door. |
| PS51, PS68 | Power Supply |
| MX, MXB | Multiplexer relay event information from the Controller to Graphic Display Panels (GDP) and to the PC. |

| | |
|----------------|--|
| LT, SB, BR, CB | Long Term (LT), Slotted Back (SB), Band Removal (BR), Cut Band (CB) Tags, small wristwatch sized device, activated Tag sends signal via receiver to the Controller. |
| TAD, PTAD | Tag activator/deactivator, also checks Tag's battery and assists in finding lost Tags. PTAD is identical to TAD except it does not activate/deactivate tags. Testing with TAD shall be conducted before use daily. |
| CL-8A | Keypad, used to disable audible device. |

Installation - The control units and accessories are intended to be installed in accordance with the following:

1. The National Electrical Code, ANSI/NFPA 70.
2. Local Authority having Jurisdiction.
3. Manufacturer's installation instructions provided with each unit.

Access Control

1. The minimum system configuration consists of Model ESI, ESRI, TW, keypad, audible device or magnetic lock or door/elevator deactivator, Tags LT and/or SB and/or BR and or CB.
2. The system shall be installed in the fail-safe mode and shall release the lock upon loss of power, loss of connection between ESI and fire alarm control panel. Loss of battery to the TAG (LT, SB, BR, CB) shall release the lock.
3. The control unit shall be mounted in a protected area.
4. The system does not provide standby power.
5. All accessories are restricted to be installed in the same room. A room is defined as an enclosed area bounded by walls extending from ceiling to floor, one or more of which may contain an entranceway that is marked with an Exit sign under the requirements of the NFPA code. An enclosed area bounded by walls from drop ceiling to floor is not considered a room but is determined to be part of the room. Rooms having no exit, as defined under the NFPA that are found within a room with exits, as defined by the NFPA, are considered part of the overall room.
6. Monitoring station is not UL Listed as an access control unit accessory.
7. This equipment is not evaluated as or meant to be installed as a burglary alarm system.
8. The Model ED is not listed as elevator equipment. The fire alarm control panel shall override the ED.

9. The magnetic switch shall be UL Listed as a connector and switches.
10. Wiring of FPI must be wired to fail-safe in an alarm or loss of power condition.
11. The Passive Infrared Detector for use with this system is not intended to be used as an intrusion detector. It is for monitoring use only.
12. The following components have not been evaluated as a UL Listed access control unit accessory (although they may carry other UL listings): Local Alarm (LA), Central Alarm CA3), Speakers (AS3), Timer (DNT), LED Tag (LED), Multi-Tone Local Alarm (MTLA), Push Button Override (PBO), Tag Test Station (TTS) (the Tx antenna portion of the TTS has not been tested), Voice Alarm (VA)
13. The detection range for a zone-activated Tag is approximately 8 ft. but the actual range shall be determined by the Installation Test (Facility Performance Testing).
14. The Tag's (LT, SB, BR, CB) battery status shall be checked with a TAD, PTAD at least twice daily.
15. The ESRR (remote receiver) may be used if the desired signal cannot be achieved with the internal receiver.
16. Models ESI and ESR are provided with a tamper switch.
17. Model ES has only been tested by UL for use in the ESI or ESR system.
18. The Tag Model CB's Pod (plastic covers) has not been evaluated by UL.
19. The Tag's (LT, SB, BR, CB) battery is not replaceable in the field.

ICS/ACCUTECH LIMITED WARRANTY

Innovative Control Systems, Inc. (ICS) warrants its Accutech™ equipment (Product) against defect in materials and workmanship under normal use for one (1) year from the date of product shipment.

Defective equipment will be either repaired or replaced at ICS' discretion, free of charge to the Customer during the warranty period. ICS will supply labor depending on contract to repair or replace defective equipment, free of charge, during the warranty period only if ICS or an ICS-certified subcontractor hired by ICS installed such equipment.

In addition, ICS warrants its Accutech™ ES 2200 / IS 3200 / BR 4200 System Tags against defects in materials and workmanship under normal use and service for a period of one (1) year from the date of shipment.

If a Tag fails during the warranty period due to defects in material and workmanship, ICS will at its sole discretion, repair or replace the Tag with like quality product free of charge, although overnight shipping charges may apply.

Furthermore, the express limited warranty of ICS shall be the sole and exclusive warranty of ICS, and ICS hereby disclaims all other warranties, express, implied or statutory, including but not limited, all other implied warranties of merchantability or fitness for a particular purpose. In no way should ICS be liable for special, incidental, or consequential damages. ICS reserves the right to change such limited warranty from time to time upon thirty (30) days written notice.

Computers and monitors provided by ICS shall not be submitted for repair to ICS but instead shall be submitted directly to their respective manufacturer and serviced under their inherent manufacturer warranty policy present at the time of purchase. Customer shall be responsible for registering any and all warranty requirements.

ICS assumes no responsibility if any Product shall fail to function during any warranty period by reason of any one or more of the following causes:

- Abuse or misuse of the Product or failure to operate the Product in accordance with operating instructions or specifications.
- Improper preventive maintenance of the Product.
- Alteration or modification of the Product not specifically approved in writing by ICS.
- Improper installation, repair, modification, or servicing the Product performed by any unauthorized service personnel.
- Equipment or cabling damaged by unauthorized personnel knowingly or unknowingly.
- Use or operation of the Product in conjunction with any accessories or auxiliary equipment not specifically approved in writing by ICS.
- Acts of God, including, but not limited to, natural disaster, fire, explosions, flood, accidents and the like.

24-hour, 7-days-a-week, 365-days-a-year over the phone technical support at 1-800-356-2671

Installation Manual

Contents

| | | |
|-------------|--|------|
| | Preface | i |
| | UL Addendum | iii |
| Chapter 1: | The Accutech Systems | 1-1 |
| Chapter 2: | Wire and Cables | 2-1 |
| Chapter 3: | The Controller | 3-1 |
| Chapter 4: | The Tx wand antenna | 4-1 |
| Chapter 5: | The Receiver | 5-1 |
| Chapter 6: | The Tag | 6-1 |
| Chapter 7: | The Keypad | 7-1 |
| Chapter 8: | The Push Button Override (PBO) | 8-1 |
| Chapter 9: | The Magnetic Switch | 9-1 |
| Chapter 10: | The Passive Infrared Reader (PIR) | 10-1 |
| Chapter 11: | Magnetic Locks | 11-1 |
| Chapter 12: | Fire Panel Interface (FPI) | 12-1 |
| Chapter 13: | Alarm Output Devices (Local Alarm, Central Alarm, Speakers, SAP, GDP) | 13-1 |
| Chapter 14: | Elevator Deactivation | 14-1 |
| Chapter 15: | Perimeter Functions | 15-1 |
| Chapter 16: | Automatic Door Deactivation | 16-1 |
| Chapter 17: | The Multiplexer | 17-1 |
| Chapter 18: | Power Supply | 18-1 |
| Chapter 19: | The Accutech Software | 19-1 |
| Chapter 20: | Tag Test Station | 20-1 |
| Chapter 21: | Band Removal Lockdown | 21-1 |
| Chapter 22: | User-Defined Settings | 22-1 |
| Appendix A: | Discontinued Components | A-1 |
| Appendix B: | Jumpers, LEDs, Pots, Switches & Fuses | B-1 |
| Appendix C: | Block Diagrams | C-1 |
| Appendix D: | Troubleshooting | D-1 |
| Appendix E: | Product Cut Sheets | E-1 |
| | Glossary | G-1 |
| | Index | I-1 |

800-356-2671 | **Accutech** | www.accutech-ics.com

The information, procedures, and advice contained herein is subject to change without notice.

Installation Manual

Chapter 1:

The Accutech Systems

IMPORTANT:

No Security System can replace human vigilance. Creating a safe environment requires the combined efforts of personnel, physicians, security, and patients. Global policies, procedures, and processes on patient care should be discussed and disseminated. Education, communication, and coordination are key. No level of security can replace an informed and knowledgeable staff. Any electronic or physical security system should be considered as a supplemental deterrent, but by no means an end-all.

The Accutech Systems

- ES 2200 System
- IS 3200 System
- BR 4200 System
- Cut Band System
- How Accutech Systems Work
- System Components
- Typical System Configurations

Throughout this manual, when referring to the various applications of the system, the term “Tag” is used to represent all possible applications of the system (i.e., a resident, a patient, an infant, pediatrics, or an asset, etc.)

Furthermore, the terms “ingress” and “egress” will be encountered. They are another way of saying “coming and going” or “entering and exiting” respectively.

The ES 2200 System is our platform system from which all Accutech System’s are built. Each subsequent system adds on to the system before. Each system can be easily upgraded as facility needs change and technology advances.

ES 2200 System

The function of the ES 2200 System is to alert facility personnel of the possible egress of a monitored resident.

The ES 2200 can be utilized for special care residents suffering from wandering malady or tendencies of straying into unauthorized areas or leaving a facility, pediatric patients, asset security and/or low-cost infant security. The system is designed so that each monitored door is a stand-alone system.

The ES 2200 System consists of a Controller, a Transmit (Tx) wand antenna, a Receiver, a Magnetic Switch, a Keypad, a Local Alarm, and an ES 2200 System Tag (LT/SB22).

When a Tag enters a monitored area, the system can automatically:

- lock doors
- deactivate elevators
- sound alarms
- flash lights
- trigger visual displays (e.g., SAPs or GDPs)

The Controller can be mounted on the wall near the point of egress or can be mounted out of sight in a utility or equipment closet.

A Tx wand antenna is typically mounted on the wall at the point of egress. However, in some cases it is possible to mount the Tx wand antenna at the zone so that it is not seen.

The Receiver is mounted internally (inside the Controller) when the Controller is located at the zone or externally (near the monitored area) when the Controller is located remotely.

Virtually any hallway, doorway or elevator can be made to sense the approach of monitored resident, and then trigger audial and/or visual alarms to prompt a staff response.

By adding options, such as the Magnetic Lock or an Elevator Deactivation Unit, most egress opportunities can be eliminated without restricting staff, visitors and non-monitored residents access.

Additional options such as the Loiter alarm, Door Ajar alarm, Local alarms, Central alarms, Passive Infrared Readers (PIRs), Staff Alert Panels (SAPs), and Graphic Displays Panels (GDPs) further enhance your ability to prevent unescorted egress.

IS 3200 System

The IS 3200 System is the ES 2200 System plus a computer with the Accutech Software installed, a TAD, a Tag Test Station, a Multiplexer, a Power Supply.

The IS 3200 System uses IS 3200 System Tags (LT/SB32) that are placed on the monitored resident or asset. Once assigned, the computer associates a name, room number and any other pertinent information about the resident/asset with that Tag.

BR 4200 System

The function of the BR 4200 and System is to alert facility personnel of the possible abduction of an infant.

The BR 4200 System is the IS 3200 System plus BR 4200 Auxiliary Receivers (as needed) and an additional alarm to announce when a band removal incident has occurred.

The BR 4200 System uses BR 4200 System Tags (BR42) that are placed on infants. In addition to the functionality of an IS 3200 System Tag, the BR 4200 System Tag will trigger alarms (visual and/or aural) if the band is removed or tampered with in any way to alert facility personnel of a possible infant abduction attempt.

Cut Band System

The function of the Cut Band System is to alert facility personnel of the possible abduction of a child. The Cut Band System is the BR 4200 System with Cut Band Tags, which will trigger alarms (visual and/or aural) if the band is cut.

How Accutech Systems Work

- Doors
- Elevators
- Hallways
- Alarms

This section explains how Accutech Systems react to a Tag entering a monitored door zone, a monitored elevator zone, and other alarm events.

NOTE: In this manual, Egress alarms are referred to as “Alarms.” Other alarm types are referred to by name (i.e., door ajar, loiter, supervise, band removal).

Doors

When a Tag enters a monitored door zone, the system will detect the Tag. At that moment (providing the door has the Magnetic Lock option, the door is closed, and the Lock is unobstructed) the doors will lock and will remain locked as long as the Tag is in the monitored door zone. When the Tag leaves the monitored zone, the door will unlock after an adjustable period of time.

If a Tag enters a monitored door zone (with or without the Magnetic Lock option) and the door is already open (or is opened while the Tag is in the zone), the Accutech System will go into alarm.

If you wish to escort a Tag through a monitored zone, you will need to enter a valid code into the zone’s Keypad to activate the Escort function. The Keypad’s Escort function will release the Magnetic Lock, silence alarms, and allow the Tag to pass through the monitored door zone for the designated Escort time. The duration of the Escort function is adjustable from 0 to 98 seconds.

An optional Loiter function is available to alert staff personnel if a Tag is in a monitored zone (even if the door or elevator is closed) for too long. The time setting is adjustable (10-110 seconds) and is factory set for 15 seconds.

An optional Door Ajar function is also available to alert staff personnel if the door in a monitored zone has been held open for too long. The time range can be set for immediate or from 10 to 110 seconds and is factory set for approximately 15 seconds.

Elevators

Elevator Deactivation Circuitry is needed to restrict the operation of a monitored elevator from a Tag.

If a Tag enters a monitored elevator zone (with Elevator Deactivation Circuitry), the elevator's call button will be deactivated for as long as the Tag is in the zone.

If the elevator car is en route to that floor and the door(s) open (or if the elevator car door is already open at that floor when a Tag approaches), the system will go into alarm and will not allow the elevator doors to close until a valid code is entered into the zone's Keypad.

If you wish to escort a Tag through a monitored elevator zone, push the call button while the Tag is out of the zone and wait for the car to arrive (when the elevator bell rings). Enter a valid code into the zone's Keypad. Then escort the Tag to the elevator door and you will be able to move the Tag between floors using the elevator.

Hallways

If a Tag enters a monitored hallway zone, the system will detect the Tag and the PIR will detect motion. The system can then sound alarms, trigger visual displays and, in special circumstances, lock nearby doors.

If you wish to escort a Tag through a monitored hallway zone, you will need to enter a valid code into the zone's Keypad to activate the Escort function. This will silence alarm and allow the Tag the pass through the monitored hallway zone for the designated Escort time. The duration of the Escort function is adjustable from 0 to 98 seconds.

Alarms

In this manual, Egress alarms are referred to as "Alarms." These alarms do not automatically reset once the Tag leaves the monitored zone or the door has been closed. They are "latched" once they have been triggered. This has been done, by design, to ensure that all alarm conditions are investigated and corrected by facility staff.

An alarm (i.e., an Egress alarm) occurs whenever a Tag enters a monitored zone **and** the door is opened *or* a PIR is triggered. To clear this alarm remove the Tag from the zone, close the door and enter a valid code into the Keypad.

Other alarm types are referred to by name in this manual. These alarms can be automatically reset once the condition(s) causing the alarm have been corrected.

A Door Ajar alarm occurs when a door is open for longer than the preset time. The door must be

closed and a Keypad Reset (or AutoReset jumper in place) to clear.

A Loiter alarm occurs when a Tag lingers in the Tx Activation Field. Remove all Tags from the Field and then enter a Keypad Reset (or AutoReset jumper in place) to clear this alarm.

A Supervisor alarm occurs when the performance of the system has been altered due to tampering or inadvertent acts such as cut wires, antenna damage or interference, etc. The alarm will reset when the condition is corrected. Contact the person outlined in your protocol for this type of alarm.

NOTE: Receiver-related supervise events can be reset by the Keypad for the duration of the supervise interval. This will silence the alarm.

A Band Alarm occurs when the BR42 Tag/band is removed or tampered with in any way or the Cut Band Tag/band is cut.

System Components

This section contains a brief description and a simple graphic (not to scale) for each component and its role in the Accutech Systems.

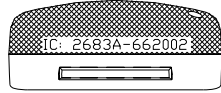
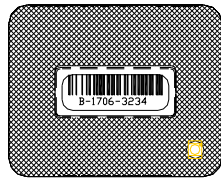
NOTE:

Accutech reserves the right to substitute comparable components.

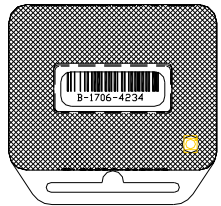
Since each facility's system is unique to its particular needs, check off the components that your facility's system has below:

Components

- The ES 2200 System Tag (LT/SB22)
- The IS 3200 System Tag (LT/SB32)
- The BR 4200 System Tag (BR42)
- Cut Band Tag
- Tag barcodes
- Visual Pulse LED
- The Tag Activator Deactivator (TAD)
- The Tag Test Station (TTS)
- The Accutech Software
- The Controller
- The Transmit (Tx) wand antenna
- The Receiver
- The Keypad
- The Push Button Override (PBO)
- The Magnetic Switch
- The Passive Infrared Reader (PIR)
- The Local Alarm
- The Central Alarm
- The Speakers
- The Multiplexer
- Power Supply
- The Staff Alert Panel (SAP)
- The Graphic Display Panel (GDP)
- Magnetic Locks
- Elevator Deactivation Circuitry
- The Fire Panel Interface (FPI)
- Timer



LT22

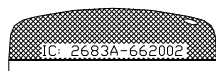
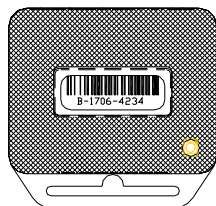


SB22

Figure 1.1
ES 2200 System Tag
(band not shown)



LT32



SB32

Figure 1.2
IS 3200 System Tag
(band not shown)

The ES 2200 System Tag

The ES 2200 System Tag (Figure 1.1) is a small wristwatch-sized device that is worn by a resident or attached to an asset.

Two models are available:

LT = Long Term resident care

SB = Slotted Back; to be used on small infants and assets

When an ES 2200 System Tag enters a Tx Activation Field (near a monitored zone), the ES 2200 System Tag activates and responds by sending a signal via the Receiver to the Controller. This information is processed by the Controller for appropriate control action or response at the zone.

ES 2200 System Tags are attached to residents/assets with a nylon-mesh vinyl band, are activated/deactivated using a TAD unit, and contain a visual pulse LED.

The IS 3200 System Tag

In addition to the look and functionality of ES 2200 System Tags, IS 3200 System Tags (Figure 1.2) are assigned to a specific resident or asset (via the Tag Test Station and a computer with the Accutech Software). The computer then associates the name, room number, and any other helpful comments about the resident or asset with that Tag.

When the IS 3200 System Tag enters a Tx Activation Field (near a monitored zone), the IS 3200 System Tag responds by sending a signal via the Receiver to the Controller while the Multiplexer sends the information to a computer with the Accutech Software and/or to Graphic Display Panels (GDPs). This information is processed by the Controller for appropriate control action or response at the zone.

IS 3200 System Tags are attached to residents/assets with a nylon-mesh vinyl band, are activated/deactivated using a TAD unit, and contain a visual pulse LED.

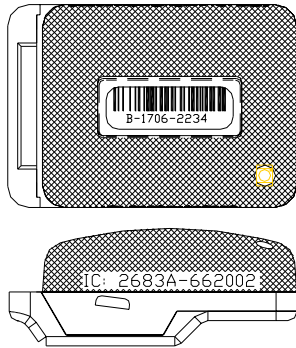


Figure 1.3
BR 4200 System Tag
(band not shown)

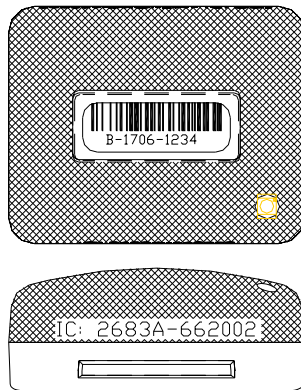


Figure 1.4
Cut Band Tag
(band not shown)

The BR 4200 System Tag

In addition to the functionality of an IS 3200 System Tag, the BR 4200 System Tag (Figure 1.3) will alarm if the band is removed or tampered with in any way.

BR 4200 System Tags are attached to infants with a conductive fiber striped-cloth band, are activated/deactivated using a TAD unit, and contain a visual pulse LED.

Cut Band Tag

Similar to the functionality of a BR 4200 System Tag, Cut Band Tags (Figure 1.4) will alarm if the band is cut and is designed for use in pediatrics applications.

Cut Band Tags are attached to patients with a Tyvek band (Figure 1.5) and plastic covers (Figure 1.6), are activated/deactivated using a TAD unit, and contain a visual pulse LED. The band contains foil adhesive that will fray during tampering. Using plastic covers with a Cut Band Tag will significantly reduce the need for sanitizing the Tag between applications.

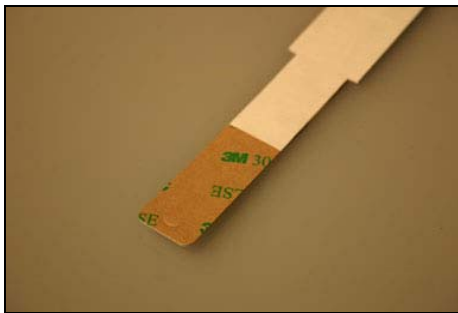


Figure 1.5 Cut Band Band

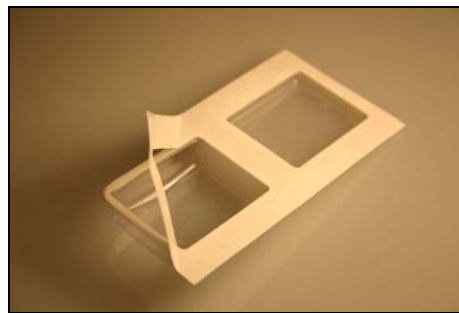


Figure 1.6 Plastic Covers

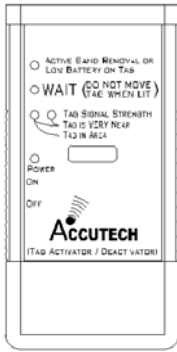


Figure 1.8
The Tag Activator/Deactivator (TAD)



Figure 1.9
Tag Test Station (TTS)



Figure 1.10
Accutech Software example



Figure 1.11
The Controller

The Tag Activator/Deactivator (TAD)

The Tag Activator/Deactivator (TAD) (Figure 1.8) turns IS 3200 System and BR 4200 System Tags on and off.

In addition, the TAD checks a Tag's battery and assists in finding lost Tags.

The Tag Test Station (TTS)

The Tag Test Station (TTS) (Figure 1.9) is used for Tag assignments.

The Accutech Software

The Accutech Software (Figure 1.10) displays events in real-time on a PC using the facility's floor plan.

The Controller

The Controller (Figure 1.11) coordinates and controls all of the devices and functions of the Accutech Systems.



Figure 1.12
Transmit (Tx) wand antenna
(shown without cover)

The Transmit (Tx) wand antenna

The Transmit (Tx) wand antenna (Figure 1.12) generates a Tag-activating signal near a monitored zone. This signal is referred to as the “Tx Activation Field.”

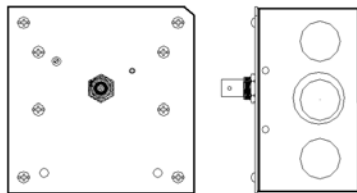


Figure 1.13
Receiver (remote shown)

The Receiver

The Receiver (Figure 1.13) picks up the signal from an activated tag and relays it to the Controller and the Multiplexer. Receivers can be internally or remotely mounted near a monitored zone. BR 4200 Zone Receivers monitor both zone events and Band Removal events. BR 4200 Auxiliary Receivers only monitor Band Removal events.

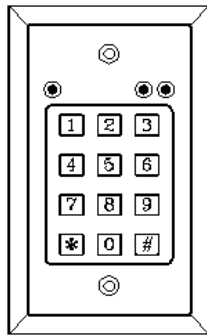


Figure 1.14 Keypad

The Keypad

The Keypad (Figure 1.14) is used to escort residents through a monitored zone and to reset zone equipment once an alarm has occurred.

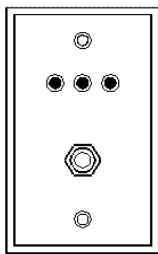


Figure 1.15
Push Button Override (PBO)

The Push Button Override (PBO)

The Push Button Override (PBO) (Figure 1.15) triggers the Keypad’s Escort function; this option allows free access through a monitored door from the non-Keypad side of the door.

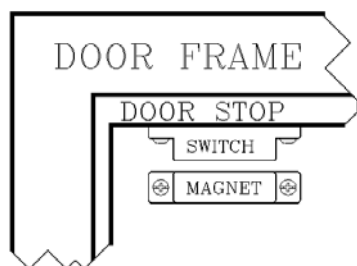


Figure 1.16 Magnetic Switch

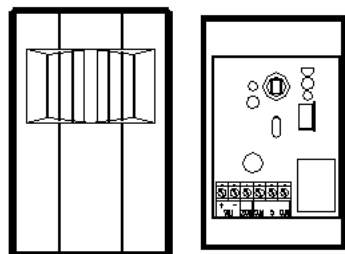
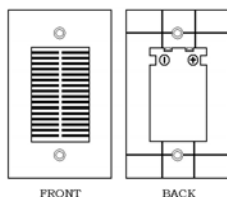
Figure 1.17
Passive Infrared Reader (PIR)

Figure 1.18 Local Alarm

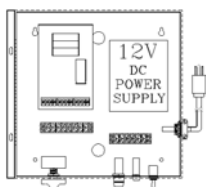


Figure 1.19 Central Alarm

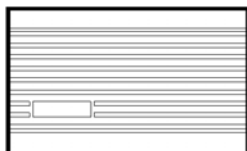


Figure 1.20 Speakers

The Magnetic Switch

The Magnetic Switch (Figure 1.16) is used on a door when alarm activation is not desired unless the door is open when a monitored resident is near that door.

The Passive Infrared Reader (PIR)

A Passive Infrared Reader (PIR) (Figure 1.17) is a device that uses a infrared sensor to monitor doors, hallways, corridors and passageways.

Like the Magnetic Switch, the PIR is used in areas where alarm activation is not desired immediately upon Tag detection. It is used in hallways or other areas where a Magnetic Switch would not be feasible.

The Local Alarm

The Local Alarm (Figure 1.18), a piezo-signaling device, is intended to attract attention near the monitored zone only.

The Central Alarm

The Central Alarm (Figure 1.19) is a multi-tone alert. It consists of a tone generator that operates Speakers located throughout a facility.

There are eight different tones available. You may choose to assign a separate tone for each zone, share the same tone for adjacent zones or use one tone for all zones.

The Speakers

The Speakers (Figure 1.20) provided by Accutech are 8-ohm speakers and used in conjunction with the Central Alarm.



Figure 1.21 Multiplexer

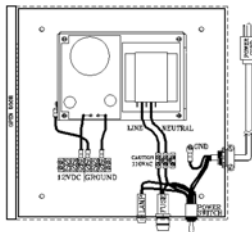


Figure 1.22 Power Supply



Figure 1.23 SAP

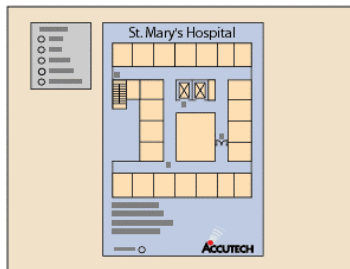


Figure 1.24 GDP

The Multiplexer

The Multiplexer (Figure 1.21) relays event information from the Controller to Graphic Display Panels (GDPs) and to a PC with the Accutech Software.

Power Supply

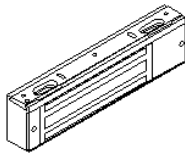
Some installations of Accutech System peripherals require more power than the Controller can provide. In these cases, a Power Supply (Figure 1.22) is added to the system to meet the additional power requirements.

The Staff Alert Panel (SAP)

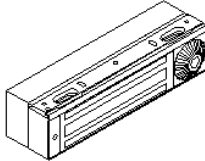
The Staff Alert Panel (SAP) (Figure 1.23), typically located at a staff station, notifies staff when an alarm condition occurs in a monitored zone through a piezo buzzer and alarm-specific LEDs.

The Graphic Display Panel (GDP)

The Graphic Display Panel (GDP) (Figure 1.24) provides the staff with a visual representation of the floor being monitored. GDPs are custom-made to a facility's floor plan and notify staff when an alarm condition occurs in a monitored zone through a piezo buzzer and alarm-specific LEDs.



3000 Series Magnetic Lock



3101 Series Magnetic Lock

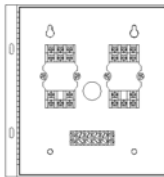
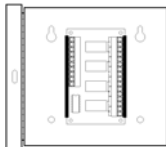
Figure 1.25
Magnetic LocksFigure 1.26
Elevator Deactivation Circuitry

Figure 1.27 FPI

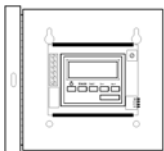


Figure 1.28 Timer example

Magnetic Locks

Magnetic Locks (Figure 1.25) prevent unescorted egress.

The 3000 Series Magnetic Lock features:

- 1500 pound holding force
- 12V to 24V AC/DC
- Unlock instantly if facility fire panel activated

The 3101 Series Magnetic Lock features:

- 1200 pound holding force
- 12V AC/DC
- Unlock instantly if facility fire panel activated
- NFPA101 Life Safety Code conformity (Delay Egress Circuitry)
- a selectable nuisance delay
- an Accutech-exclusive electromagnetic coil
- an Accutech-exclusive firmware chip

Elevator Deactivation Circuitry

Elevator Deactivation Circuitry (Figure 1.26) prevents monitored residents from using an elevator.

The Fire Panel Interface (FPI)

The Fire Panel Interface (FPI) (Figure 1.27) ensures that in the event of a fire alarm, the Magnetic Lock and Elevator Deactivation Circuitry will disengage. Although the restraint systems are disengaged, the system visual and audial alarms remain active.

Timer

A Timer (Figure 1.28) allows the user to engage/disengage certain system functions on a time schedule.

Typical System Configurations

- Single Door Example
- Remote Single Door Example
- Double Door Example
- 6 to 8 foot Elevator Example

The following are lists of the components used in each of the more typical zones encountered. They are accompanied by graphics that are intended merely as suggestions as to where the components should be placed in relationship to the opening being covered. They are shown with a “drop” ceiling, where it is typically easy to access an “out of the way” area.

The chapters that follow will more clearly define the parameters used to determine component locations. As always, common sense, local codes, and consultation with your Accutech Representative will go a long way toward answering many of your questions.

Single Door Example

(Figure 1.29)

(Controller mounted at door, above drop ceiling)

- 1-Accutech Controller/Receiver (Ch. 3; Ch 5)
- 1-Accutech Tx wand antenna (Ch. 4)
- 1-Magnetic Switch (Ch. 9)
- 1-Keypad (Ch. 7)
- 1-Local Alarm (Ch. 13)
- 1-Cable Kit (Ch. 2)

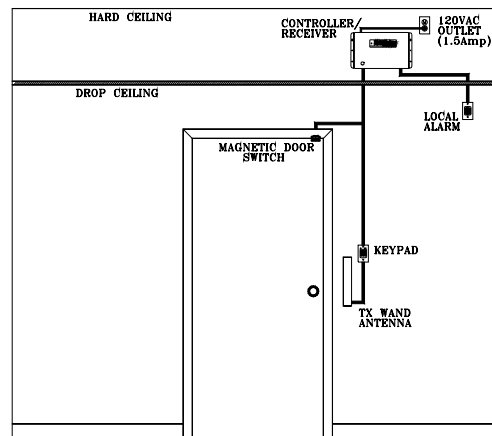


Figure 1.29 Single Door Example

Remote Single Door Example

(Figure 1.30)

(Controller mounted remotely, in utility room)

- 1-Accutech Controller (Ch. 3)
- 1-Remote Receiver (Ch. 5)
- 1-Accutech Tx wand antenna (Ch. 4)
- 1-3101 Magnetic Lock (Ch. 11)
- 1-Magnetic Switch (Ch. 9)
- 1-Keypad (Ch. 7)
- 1-Local Alarm (Ch. 13)
- 1-Cable Kit (Ch. 2)
- 1-Junction Box
- 1-Composite Cable (specify length) (Ch.2)

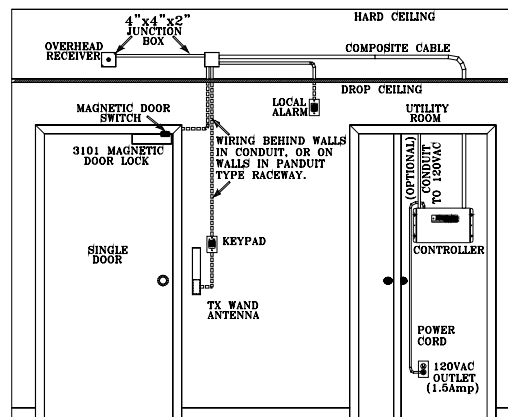


Figure 1.30 Remote Single Door Example

Double Door Example

(Figure 1.31)

(Controller mounted at door, above drop ceiling)

- 1-Accutech Controller/Receiver (Ch. 3; Ch 5)
- 2-Accutech Tx wand antennas (Ch. 4)
- 2-Magnetic Switches (Ch. 9)
- 1-Keypad (Ch. 7)
- 1-Local Alarm (Ch. 13)
- 1-Cable Kit (Ch. 2)

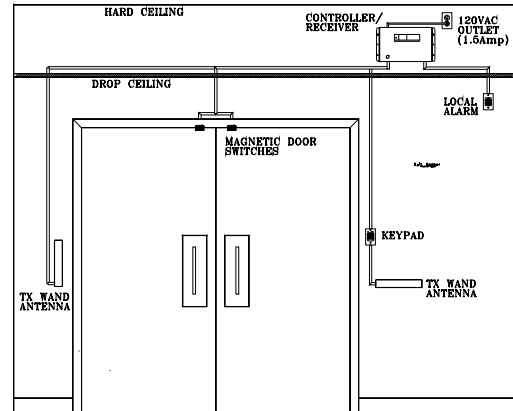


Figure 1.31 Double Door Example

6 to 8 Foot Elevator Example

(Figure 1.32)

(Controller mounted at elevator, above drop ceiling)

- 1-Accutech Controller/Receiver (Ch. 3; Ch 5)
- 2-Accutech Tx wand antennas (Ch. 4)
- 1-PIR (Passive Infrared Reader; Ch. 10)
- 1-Keypad (Ch. 7)
- 1-Local Alarm (Ch. 13)
- 1-Cable Kit (Ch. 2)

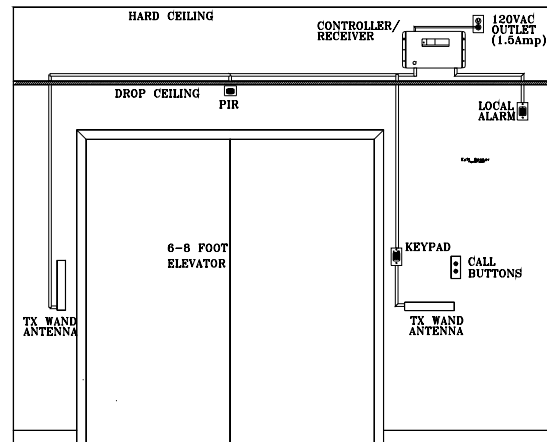


Figure 1.32 6-to-8 Foot Elevator Example

Installation Manual

Chapter 2:

Wire and Cables

Wire and Cables

- Cable Door Kit
- SAP and GDP Cable Specifications
- Fire Panel Cable Specifications
- Composite Cable
- Wire Gauge Table

Each component in the Accutech Systems has its own wiring requirements.

They have been determined by:

- the amount of Current they will draw
- the Voltage they require
- the type of Signal they will carry
- the Distance the signal can/will travel
- the type of environment the cables will be exposed to
- National Fire Prevention Association (NFPA) codes
- National Electrical Code (NEC)

All cables used by Accutech are “Plenum” rated unless otherwise specified. This allows them to be run in areas that other cable would not be allowed.

Be sure you consult Local, State, and Federal codes as well as with your Accutech Representative before making any wiring substitutions.

Cable Door Kit

Accutech’s Cable Door Kit (see Table 2.1) is the building block for the installation of any type of zone. As options are added additional wire or cables will be required.

SAP and GDP Cable Specifications

The addition of a SAP or GDP to your system will require additional cables. SAPs and GDPs require a run of 22-gauge, 6-conductor cable from each zone Controller to the respective Panel. Consult Table 2.2 on page 2-4 to determine the necessary gauge versus the distance from the source to the SAP or GDP.

Furthermore, SAPs and GDPs have a fire alarm indicator LED that is designed to receive a signal from the Fire Panel Interface (FPI) unit. Using 22-gauge, 2-conductor cables should be adequate up to 1000 feet for this task.

| Table 2.1 Accutech Cable Door Kit # 700150 Contents | | | | |
|--|-----------------------------|------------------|-----------------------|------------------------------|
| Accutech Part # | Gauge/ Conductor | Shielded? | Length in Feet | Used for |
| 200302 | 18/6 | No | 30 | Lock |
| 200306 | 22/2 | No | 40 | Magnetic Switch; Local Alarm |
| 200304 | 22/4 | No | 65 | Keypad |
| 200307 | 18/2 | Yes | 50 | Tx wand antenna |

Fire Panel Cable Specifications

The addition of a Lock requires an interface to the Fire Panel. If future expansion of the system is a possibility, it is recommended that you use a Fire Panel Interface (FPI) unit.

If expansion is not possible and there are only one or two zones, a Fire Panel Relay (with 3 sets of dry contacts) can be used instead.

If a FPI unit is used, you will need to run a separate 2-conductor cable from one of the zone Controllers to the FPI unit to provide power. You may choose to run a length of 4-conductor and include the wire for that unit's dry contacts in the cable as well.

Furthermore, a length of 22-gauge, 2-conductor will need to go from the FPI to each SAP's or GDP's Fire Alarm indicator LED.

NOTE: Some installations may allow for the FPI to be mounted very near a SAP. You could then include the Fire Contacts in the same run of cable as the SAP or GDP. This can minimize long, multiple runs of cable considering that there are connections between each of these three units.

Composite Cable

- Technical Specifications

NOTE: For easier installation, Accutech Composite Cable (Part # 200355) was replaced with Composite Cable (Part # 200371) on June 1st, 2004. For information on the previous composite cable, see page A-5.

Accutech offers a “composite” cable (Figure 2.1; Part # 200371) for wire runs from the Controller to a Junction Box when the Controller is mounted away from the zone.

At the zone, use the cable kits supplied with the system to run from the Junction Box to the individual components at the zone.

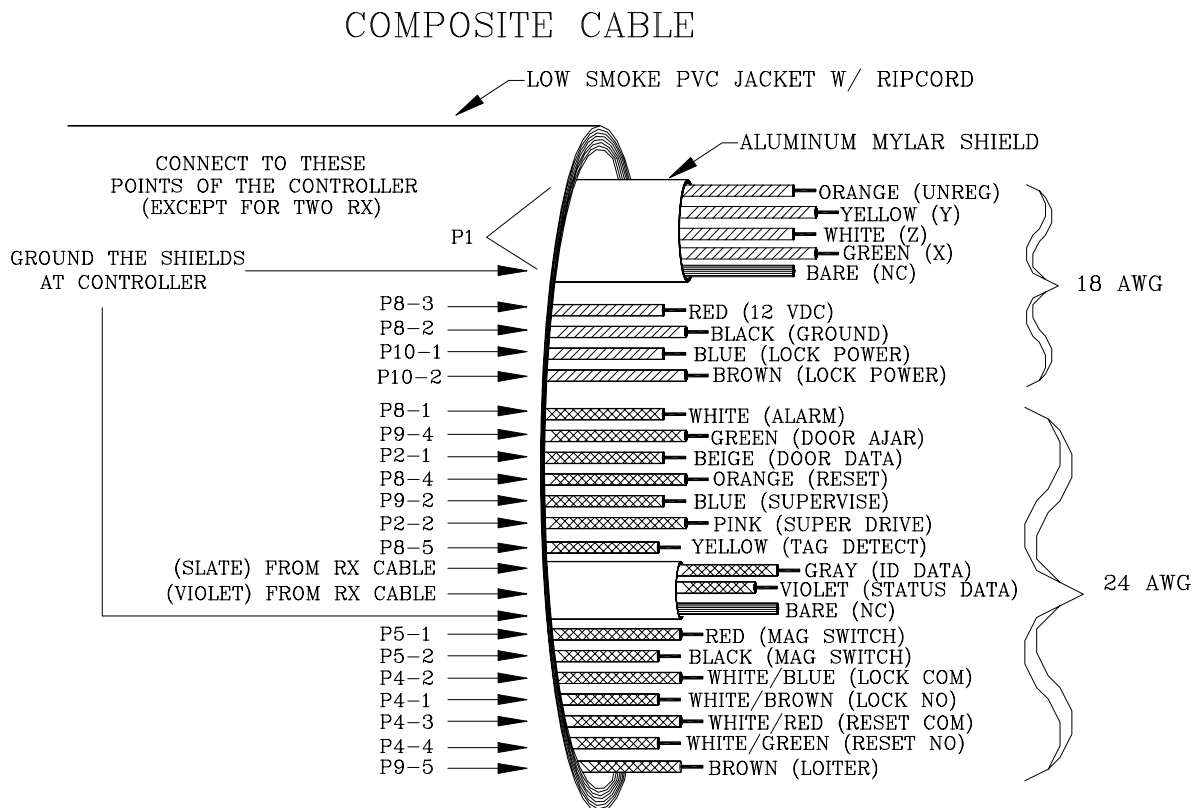
When wiring composite cable, use the same color code throughout the Accutech System (Figure 2.1).

Technical Specifications

The technical specifications for the Accutech Composite Cable (Part # 200371) are:

- A four-element Plenum-rated composite cable
- Element 1: 18 gauge 4 conductor shielded Mid-Cap (Color code: orange, yellow, white, green)
- Element 2: 18 gauge 4 conductor non-shielded (Color code: red, black, blue, brown)
- Element 3: 24 gauge 2 conductor shielded (Color code: gray, violet)
- Element 4: 25 gauge 14 conductor non-shielded (Color code: white, green, beige, brown, orange, blue, pink, yellow, red, black, white/blue, white/brown, white/red, white/green)
- Each element is individually wrapped with a clear mylar binder and all elements are cabled together
- Jacket Material: Low Smoke Polyvinylchloride (PVC)
- Jacket color: yellow
- Jacket Ripcord: Yes
- Jacket Print: "18 AWG 4C SHIELDED + 18 AWG 4C + 24 AWG 2C + 24 AWG E171202 (UL) CL3P OR CMP C (UL) 75 ° www.accutech-ics.com 800-356-2671"
- Ascending/Descending Footage Markers
- Diameter: nominal 0.386"
- Made in accordance with UL Subject 444, NEC Type CMP

Figure 2.1
Composite Cable (Part # 200371) Conductor Uses and Color Code



* SHIELD WIRE SHOULD BE PREFERABLY CONNECTED AT CONTROLLER AND CLIPPED AT J-BOX ABOVE DOOR *

Table 2.2 Wire Gauge Table - For common system devices

The following table indicates the recommended minimum wire gauge for a given length of cable. This table reflects the fact that there are two conductors, power and ground, running to each device.

Note: 1000 feet of cable means the supply current travels a total of 2000 feet.

| Supply Voltage (DC) | V Min. | Peripheral Device: | Current @12V AC/DC | 1'-25' | 25'-100' | 100'-250' | 250'-500' | 500'-1000' | 1000'-000' |
|---------------------|--------|-----------------------------|--------------------|--------|----------|-----------|-----------|------------|------------|
| 12V | 10V | Local Alarm | 12mA | 24 | 24 | 24 | 24 | 24 | 24 |
| 12V | 9V | Central Alarm | 100mA | 24 | 24 | 24 | 22 | 18 | 16 |
| 12V | 9V | Keypad | 55mA | 24 | 24 | 24 | 24 | 22 | 20 |
| 12V | 9V | Keypad w/ PBO | 75mA | 24 | 24 | 24 | 24 | 22 | 18 |
| 12V | 6V | Magnetic Switch | 25mA | 24 | 24 | 24 | 24 | 24 | 18 |
| 12V | 9V | SAP | 150mA | 24 | 24 | 24 | 24 | 24 | 18 |
| 12V | 9V | GDP | 500mA | 24 | 24 | 24 | 24 | 24 | 18 |
| 12V | 9.5V | PIR | 10mA | 24 | 24 | 24 | 24 | 24 | 18 |
| 12V | 11V | Multiplexer | 500mA | 18 | 18 | 18 | 18 | 18 | 16 |
| 12V | 9V | Elevator Deactivation Relay | 100mA | 18 | 18 | 18 | 18 | 18 | 18 |
| 12V | 10.5V | 3000/3101 Lock* | 450mA | 18 | 18 | 18 | 18 | 16 | 12 |
| 12V | 10.5V | 3000/3101 Lock** | 900mA | 18 | 18 | 18 | 16 | 12 | 10 |

*This is for one lock, receiving 12VAC from the Controller.

**This is for two locks, in parallel, receiving 12VAC from the same Controller.

Installation Manual

Chapter 3:

The Controller

The Controller

- Controller Specifications
- Mounting the Controller at the zone
- Remote Mounting the Controller
- Hard Wiring Power
- The System Supervisor
- Tamper Switch

The Controller coordinates and controls all of the devices and functions of the Accutech Systems.

Controller Specifications

- Power Requirements
- Temperature
- Weight
- Location

Power Requirements

- 120V AC, 1.0 amp
A dedicated 120V AC, 15-amp circuit with emergency backup is recommended.
- Each Controller comes with a grounded 6-foot power cord for ease of installation.
- A three-prong 120-Volt outlet with emergency back up should be located within 6 feet of each Controller.

Temperature

The Controller and its associated peripherals operate best in an ambient temperature between 35 and 90 degrees Fahrenheit. Operation outside of this range may cause unexpected or undesirable results, including premature component or device failure.

Weight

The Controller weighs approximately 13 U.S. pounds, which should be considered when choosing mounting location and hardware.

Location

The recommended location of the Controller is out of sight above a drop ceiling near the monitored zone. If it is not possible to mount the Controller out of sight, place the Controller high on the wall.

By default, the Controller is factory configured to use an internally mounted zone Receiver. However, if desired, a remote mounting system can be used to mount the Receiver at the zone allowing the Controller to be mounted in a utility closet or other concealed location.

Mounting the Controller at the zone

To mount the Controller, refer to Figure 3.1 and use the following instructions:

1. Mark-out and drill 4 mounting holes in the wall corresponding to the mounting holes of the Controller.
2. Using appropriate hardware for the mounting surface, install the four anchors, then the upper two screws leaving about a 1/8th of an inch exposed.
NOTE: The hole spacing on the Controller is 16" on centers, which is typical wall stud spacing.
3. Remove the Controller cover.
4. Align the large "key-way" holes with the upper screws and gently guide the Controller base onto the screws allowing the unit to hang from these screws temporarily.
5. Determine which knock-outs will be used for bringing the wires and/or cable into the Controller. Remove the Controller from the upper screws, remove the appropriate knock-outs and install the proper fittings and/or bushings.
6. The Controller is shipped with an internally mounted Receiver (mounted backwards to protect the antenna connector in shipment). You will need to flip the Receiver around.
7. Refer to Figure 3.1 and remove the two mounting screws that attach the Receiver to the Controller.
8. Flip the Receiver around and re-mount it.
NOTE: Be sure to keep the wire harness connections intact during this move.
9. Make any and all conduit connections that require the Controller to be unmounted.
10. Position the Controller back on the first two screws and install the last two mounting screws then tighten all 4 mounting screws.
11. Punch out the Receiver antenna knock-out on the Controller cover.
12. Replace the Controller cover and attach the Receiver antenna.

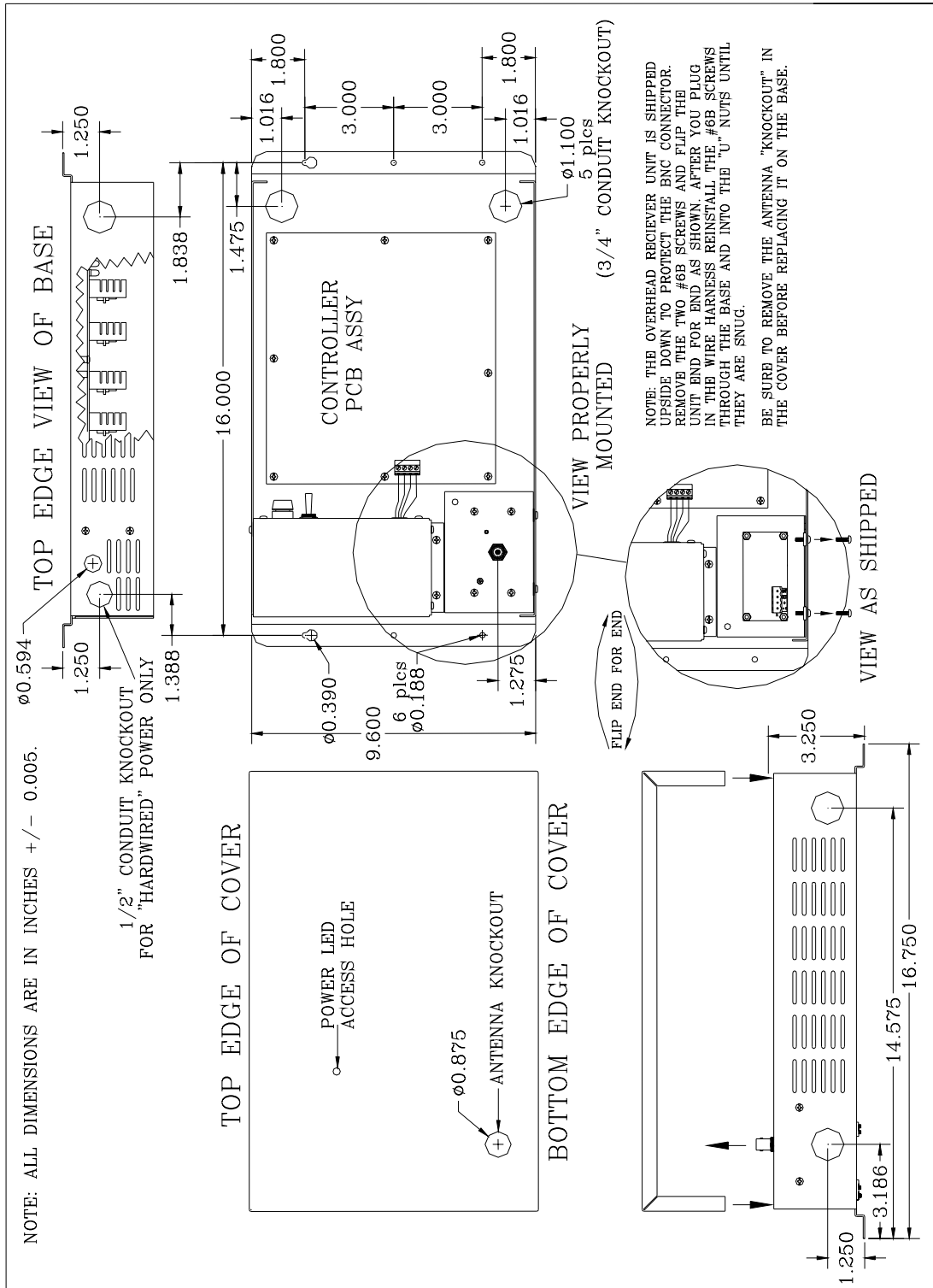


Figure 3.1 Mounting the Controller

Remote Mounting of the Controller

To mount the Controller remotely, follow the same instructions as you would to mount the Controller locally.

However, remote mounting of the Controller requires that a Remote Receiver be positioned at the zone. The Receiver, normally mounted inside of the Controller, requires a different mounting plate and a 4"x4"x2" electrical box.

Furthermore, using a composite cable (available from Accutech) will greatly ease the pulling of wire from zone components to the Controller. The composite cable is a multi-conductor cable that is color coded to provide ease of installation. In order to make it easier for Accutech personnel to offer assistance, either over the phone or in person, please be consistent in following the color-coding for the Composite Cable stated on page 2-3.

Finally, a 4"x4"x2" junction box (also available from Accutech) is recommended to make the connections between zone components and the Controller.

Hard Wiring Power

If installation requires that the Controller power be hard wired, then the Controller's power cord must be removed.

WARNING: Before making any attempt at hard wiring, turn off the power and unplug the Controller.

NOTE: Only a certified electrician or equivalent should attempt hard wiring.

To hard wire the Controller, refer to Figure 3.2 and use the following instructions:

1. Remove the Controller cover by removing the screws.
2. Remove the Power Supply cover by removing the 4 mounting screws.
3. On the three-position power terminal strip, remove the 3 power cord wires* by loosening the 3 terminal screws that hold them in place.
***NOTE:** On newer models, the Green wire coming from the power cord will go directly to a chassis ground instead of a terminal block.
4. Using pliers to squeeze the cord strain relief bushing, remove the power cord.
NOTE: A suitable plug or cap should be put in the power cord hole.

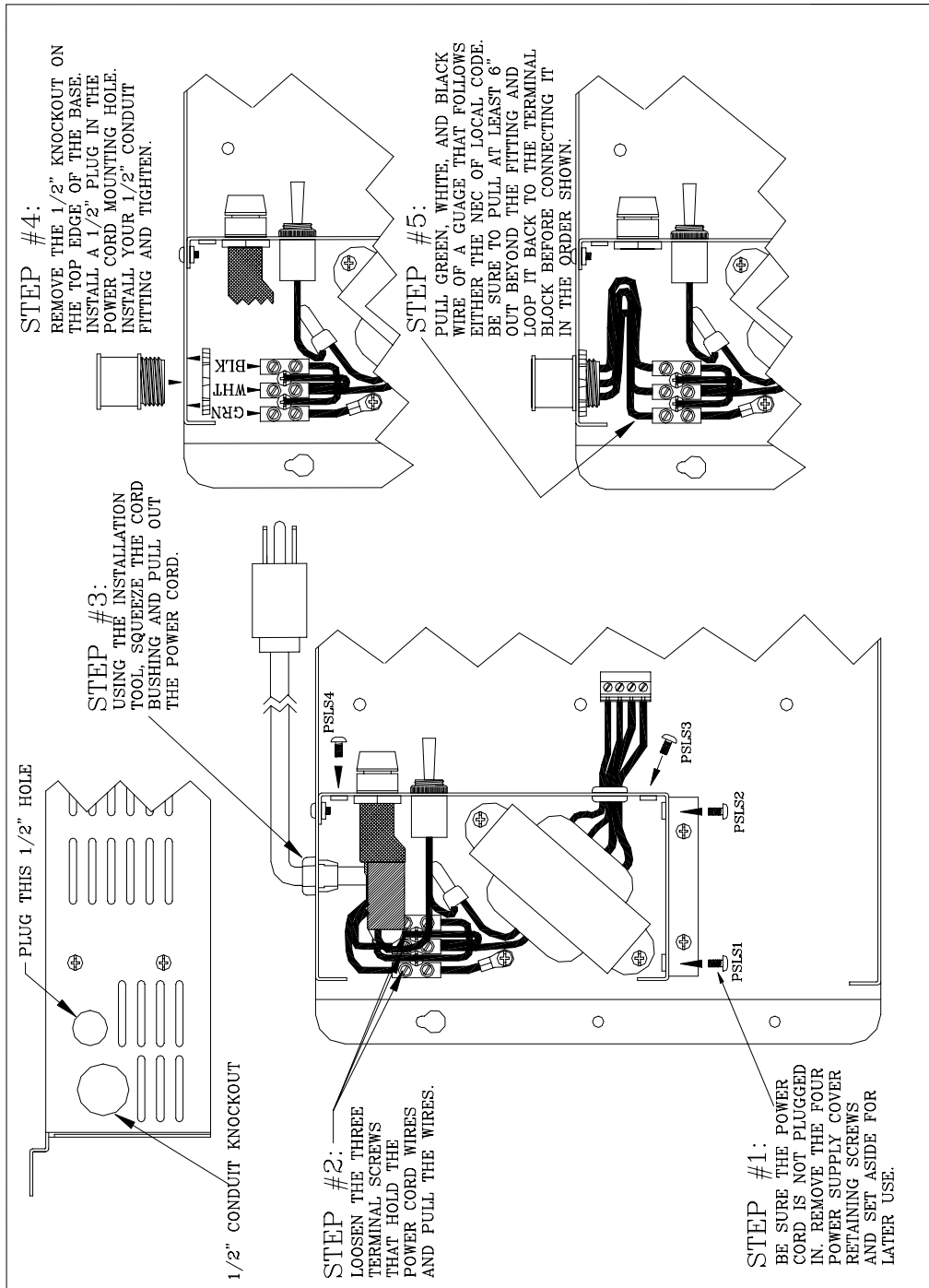


Figure 3.2 Hard wiring the Controller

5. Punch out the ½” conduit fitting knock-out and install a proper conduit fitting for the connection you are making.
6. After your conduit runs are complete and tight, fish solid 14-gauge conductor from the power source through to the power terminal strip. Be sure to leave yourself 4-6” of excess wire to work with.
7. Replace the Power Supply Cover.
8. Turn on the power to test the connections.
NOTE: The Red wires from the secondary of the transformer carry approximately 15V AC. The Blue wires carry approximately 30V AC.
9. Once hard wire power has been verified, make sure the Power Switch on the Controller is turned off.
10. Replace the Controller cover.

The System Supervisor

- Supervisor Threshold
- Power Loss Supervise Alarm

The System Supervisor, is a built-in self-diagnostic circuit, continuously monitors the Tx Activation Field and periodically simulates a Tag in the zone.

If the System Supervisor detects a problem, the zone’s Controller will begin to alarm via a piezo buzzer (provided jumper JP13 is in place) and on SAPs/GDPs and the Accutech Software.

The System Supervisor will initiate an alarm when:

- Certain “critical” wires are cut or broken
- Certain “critical” components fail
- The Tx Activation Field is compromised by a metal structure (such as a food cart) or by radio frequency interference.
- The system loses power (battery required).

JP5 (Table 3.1) determines how often the System Supervisor checks each Zone Receiver in the Accutech System.

| Table 3.1 JP5 Positions and Results | |
|-------------------------------------|---|
| Position | Result (Check system Once/Time Interval) |
| 1 | Test (testing purposes only) |
| 2 | Demo; Once/min (demonstration purposes only) |
| 3 | Once/ 2 Hours |
| 4 | Once/ 4 Hours |
| 5 | Once/ 8 Hours |
| 6 | Once/16 Hours |
| 7 | Disable |

NOTE: JP5 Positions 1 and 2 are only for testing and demonstration purposes; they should not be used during normal operation.

If desired, the System Supervisor can also be wired to trigger an external alarm (e.g. Local Alarm)

A common System Supervisor condition is that a large metal object (such as a food cart) has been placed very near the Tx wand antenna and has diminished the Tx Activation Field.

NOTE: Receiver-related supervise events can be reset by the Keypad for the duration of the supervise interval. This will silence the alarm.

Supervisor Threshold

The Supervisor Threshold Level is set using potentiometer R26 and should be set at the second bar from the bottom of LED13. For more information see page B-7 (for LED13), B-10 (for R26), and B-12 (for S3).

Power Loss Supervise Alarm

The Controller also has a Power Loss Supervise function that will indicate that the system power has been lost.

To activate this feature a jumper must be placed in JP13 (Piezo Enable) and a rechargeable 9-volt **NiCad** (nickel-cadmium) battery (purchased separately) must be installed in the battery clip connected to P12 of the Controller.

When the battery is installed and the power is applied to the Controller, the battery is being trickle charged constantly. When

power is lost to the Controller, the Piezo Alert of the Controller will sound for as long as the 9-volt battery has enough power to drive the Piezo.

NOTE: To avoid possible damage or wear and tear to the battery cable, connector, the battery itself, or interference with the wiring within the Controller case, the battery should be secured to the inside of the Controller case with Velcro, Double Stick tape, or a Tie wrap.

WARNING:

For the Power Loss Supervise function, use a 9-volt **Ni-Cad** (**nickel-cadmium**) rechargeable battery **ONLY** as other types of batteries may explode or leak causing damage to the Controller or injury to the person(s) working on the equipment.

WARNING:

If a battery is not installed, make sure that the battery clip cover is in place over the battery lead terminals. If you have lost the cover, then be sure to cover the terminals of the battery clip with electrical tape or heat shrink tubing before you apply power to the unit. Failure to do so can result in the terminal leads shorting to the case causing damage to the Controller or electric shock.

Tamper Switch

UL 294 requirements call for the installation of a “tamper switch” that engages the lid, and is wired so as to cause an alarm if the lid is removed.

When the tamper switch is installed and the lid is removed, a Tx Supervise alarm will be generated and LED14 will illuminate red. To remedy the alarm, replace the lid.

The switch is mounted with #4-40, ½” machine screws, star washer, and nut to the Controller case (Figure 3.4).

To wire the tamper switch, use Figures 3.3 - 3.4 and the following instructions:

1. The **BLACK** wire of the tamper switch goes to the “X” Tx wand antenna at the “Antenna” terminal (Figure 3.3).
2. The **WHITE/BLUE** wire of the tamper switch goes to the “X” terminal of the Controller (P1-2). (Figure 3.4)

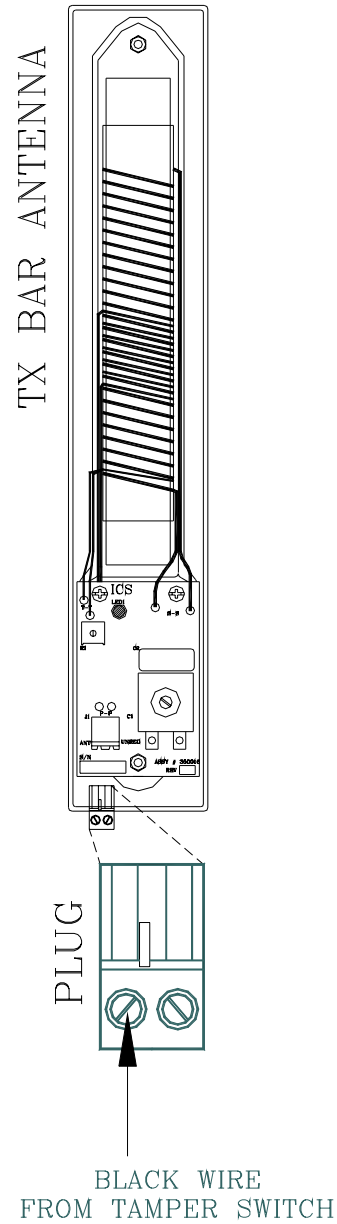


Figure 3.3
Tamper Switch antenna connection

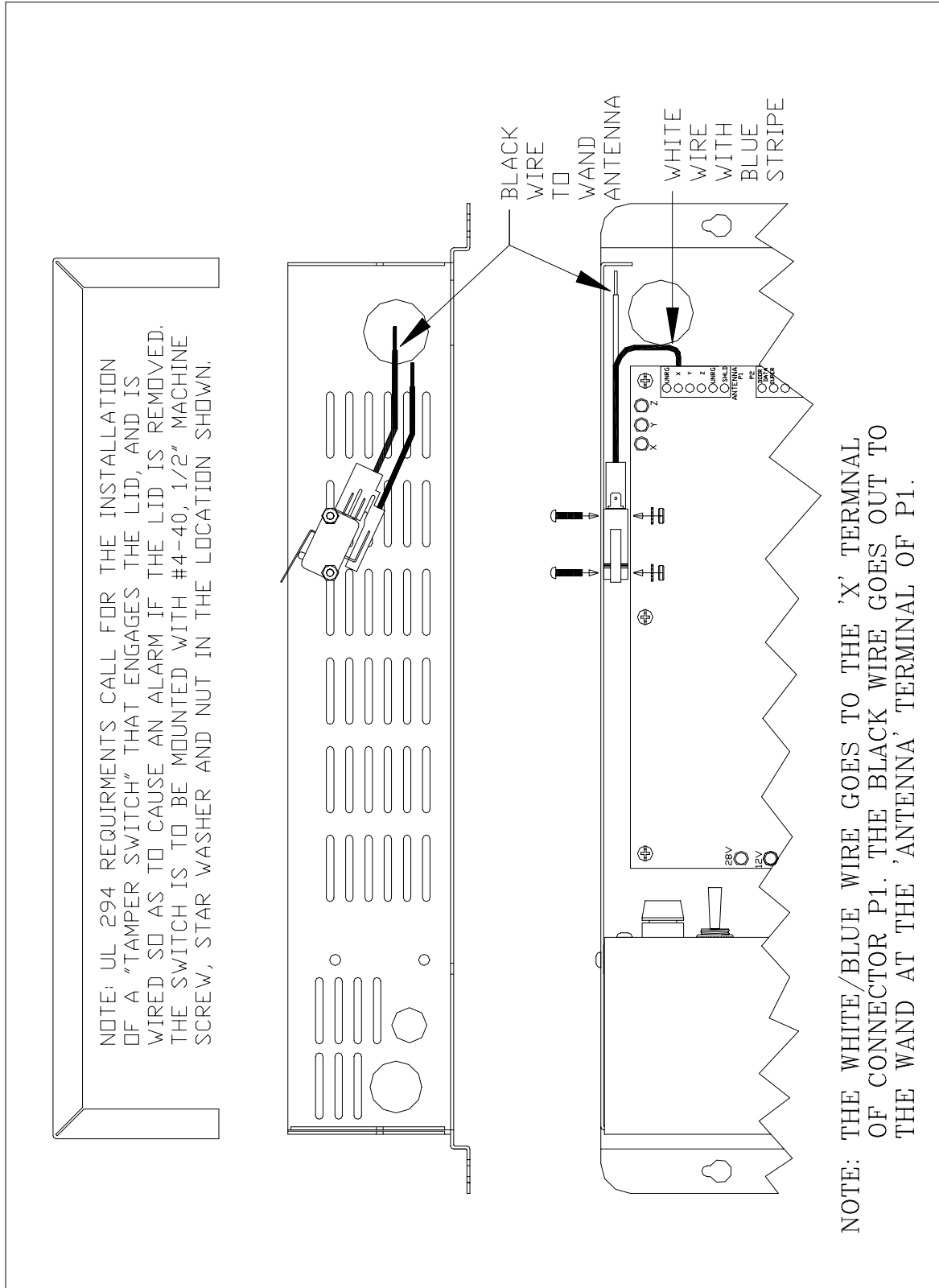


Figure 3.4 Connecting the Tamper Switch

Installation Manual

Chapter 4:

The Tx wand antenna

The Tx wand antenna

- Tx wand antenna Specifications
- Single Door Applications
- Double Door Applications
- Spacing Tx wand antennas at the Same Zone
- Mounting a Tx wand antenna
- Connecting a Tx wand antenna to the zone Controller
- Stagger Tuning
- Why Re-tune the Tx wand antenna?
- Tuning a Tx wand antenna
- Alternate Tuning Method
- Adjusting the Tx Activation Field

A Tx wand antenna (Figure 4.1 and 4.2) located at a zone generates a Tag activating, radio frequency signal called the “Tx Activation Field.”

When a Tag is activated it sends a signal to the Receiver. The Receiver then sends the signal to the Controller, which validates the signal before initiating any action such as locking a door, deactivating an elevator or triggering system alarms.

Tx wand antenna Specifications

- Power Requirements
- Temperature
- Weight
- Location

Power Requirements

Provided by Controller

Temperature

Tx wand antennas operate best in an ambient temperature between 35 and 90 degrees Fahrenheit. Operation outside of this range may cause unexpected or undesirable results, including premature failure.

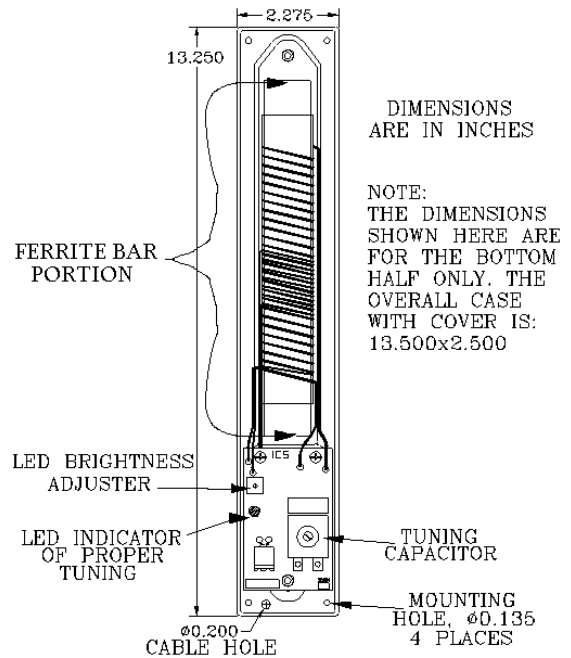


Figure 4.1
A Tx wand antenna (with cover off)

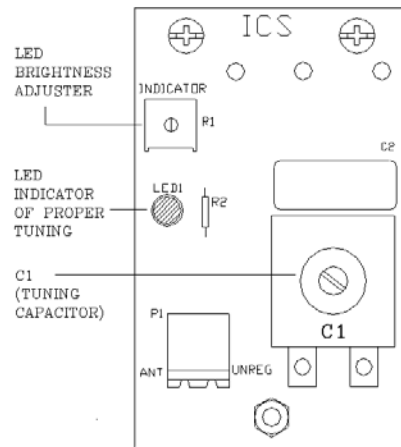


Figure 4.2 Tx wand antenna PCB

Weight

A Tx wand antenna weighs approximately 1.5 U.S. pounds, which should be considered when choosing mounting hardware.

Location

Position the antenna on the *latch* side of the door with its lowest point about 3 feet above

the floor and at least **3** inches away from any metal doorframe (Figure 4.3). A 3-inch wood or plastic spacer may be used to keep the antenna away from a metal door frame. In some circumstances due to a building's construction, it may be necessary to mount the antenna on the hinge side of the door.

Furthermore, **never** mount any metal electrical box or run conduit right behind the “ferrite” bar portion of the antenna (Figure 4.1). However, it is acceptable to mount the metal box so that it is directly behind the circuit board only.

In addition, the antenna should be positioned within 18 inches **maximum** of the monitored door to assure proper coverage. The recommended distance is from 3 to 6 inches. Positioning the antenna correctly will help in avoiding unintended activation of a Tag in a nearby room or a passerby. The goal is to produce a Tx Activation Field that adequately covers the doorway but does not extend into nearby resident rooms. For more information, see Tuning a Tx wand antenna on page 4-7.

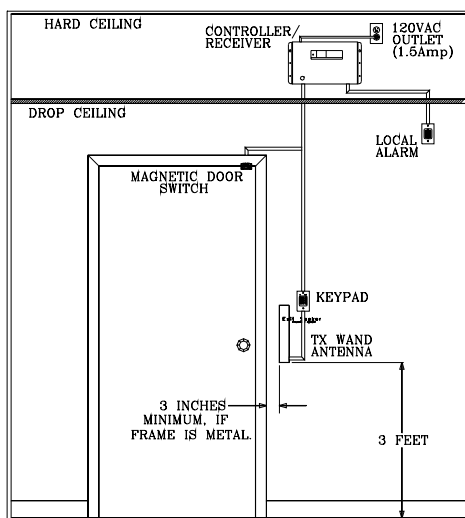


Figure 4.3 Single Door Placement

Single Door Applications

A single door application (Figure 4.3) usually requires only one antenna for adequate coverage.

Double Door Applications

For a double door or hallway application 6 feet or wider (Figure 4.4), two antennas are usually required.

If you are protecting a double door or hallway, which is adjacent to a resident's room, you should turn down the Tx Activation Field on the antenna (see page 4-14) that is nearest the resident's room to avoid nuisance activation.

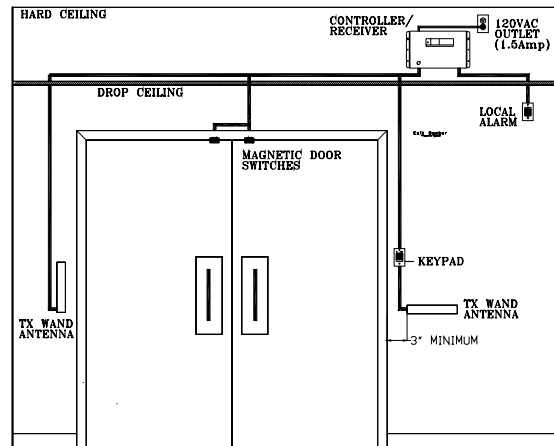


Figure 4.4 Double Door Placement

Spacing Tx wand antennas at the Same Zone

It is recommended that the distance between antennas for a double door or hallway application should not be greater than 8 feet.

If the opening is greater than 8 feet wide, then it may be necessary to add a third antenna, mounted in a horizontal position above the door or hallway to assure full coverage.

NOTE: When using multiple antennas, it is necessary to install jumper JP4 on the Controller board. Install in position 2-3 for two antennas, or position 1-2 for three antennas. For more information on jumper JP4, see Appendix B-1.

Mounting a Tx wand antenna

Use the following instructions to mount a Tx wand antenna:

1. Select appropriate screws and wall anchors for the mounting surface.
2. Using the spanner key supplied, take off the antenna cover by removing the two spanner security screws and slipping the cover off of the base.
3. If the antenna cable is to be fished through the wall only, decide where you will mount the antenna and go to step 4.

If not, consider the following before you proceed to step 4:

- If the cable is being run through wire molding, cut a small notch in the Tx wand antenna plastic case where the molding meets the antenna case to facilitate wire entry.
- If the cable is required to run through conduit due to building codes, then be certain not to run any conduit directly behind the antenna's "ferrite" bar.
NOTE: Running cable through conduit is **not** recommended because it may de-tune the antenna and/or the

cable thus negatively affecting the system's performance.

- If conduit is used, a single gang box can be used to terminate the connection, but it must be mounted so that it will be directly behind the circuit board of the antenna only and not behind the ferrite.
4. Using the antenna as a template, mark the four mounting holes.
NOTE: Use the antenna as a template only for marking the holes; **do not** attempt to drill while holding the antenna to the mounting surface.
 5. Drill the 4 mounting holes in the mounting surface.
 6. Fish 18-gauge, 2-conductor shielded cable through the wall, raceway, or conduit and out through the middle hole at the bottom of the antenna. The cable will be used to connect the antenna to the zone Controller.
 7. Secure the antenna to the mounting surface with appropriate hardware.

Connecting a Tx wand antenna to the zone Controller

To connect a Tx wand to the zone Controller, refer to Figure 4.5 (and if applicable, Figures 4.6 and 4.7) and use the following instructions:

1. Using the **RED** wire, connect the “UNREG” on the antenna (pin P1-2) to “UNREG” on the zone Controller (pin P1-5).
NOTE: When multiple antennas are being used, each subsequent antenna should have its **RED** wire connected to one of the two “UNREG” positions on the zone Controller (P1-1 or P1-5).
2. Using the **BLACK** wire, connect the “ANT” on the antenna (pin P1-1) to “X” on the zone Controller (pin P1-2).
NOTE: When multiple antennas are being used, the second antenna’s BLACK wire should be connected to “Y” (pin P1-3) and the third antenna’s BLACK wire should be connected to “Z” (pin P1-4).
3. Regardless of how many antennas are being used, the bare “**SHIELD**” wire from each antenna cable should be tied together and connected at the “**SHIELD**” position (pin P1-6) on the zone Controller. The shields wires are **not** to be connected to the antenna.
4. After the antenna(s) are connected and tuned properly (see page 4-7), replace the antenna cover(s).

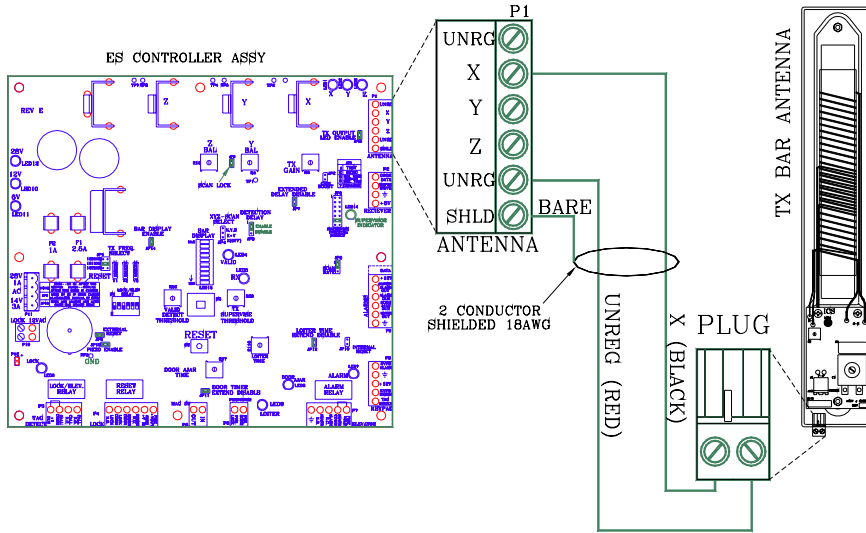


Figure 4.5 Connecting a Tx wand antenna to the zone Controller

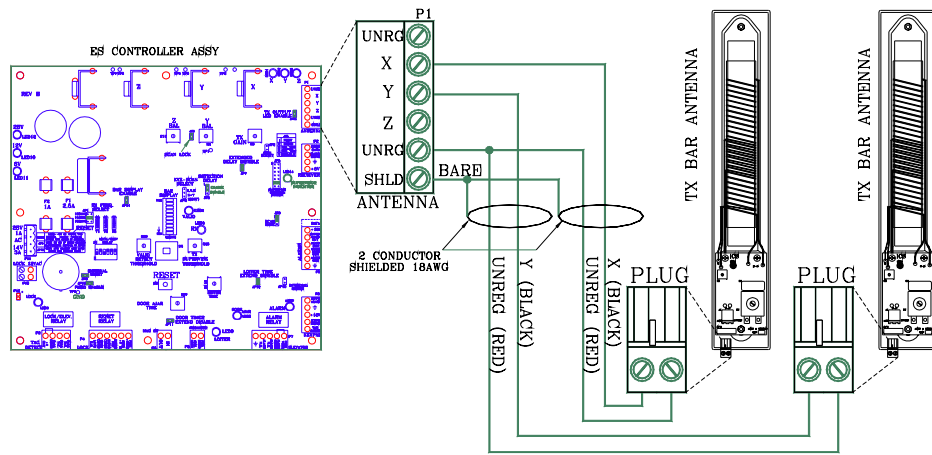


Figure 4.6 Connecting two Tx wand antennas to the zone Controller

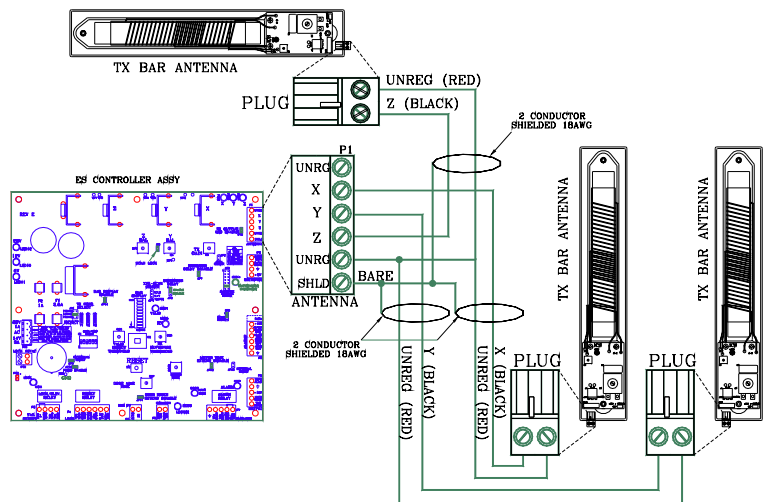


Figure 4.7 Connecting three Tx wand antennas to the zone Controller

Stagger Tuning

- Implementing Stagger Tuning

Stagger Tuning allows monitored zones to be located closer than the normal minimum 70 feet distance by using different Tx operating frequencies for adjacent zones so that Tags activated in one zone do not create events (locks, alarms, etc.) in another zone.

Implementing Stagger Tuning

The Controller comes from the factory with 3 different crystals, Y1 (130 KHZ), Y2 (131.072 KHZ) and Y3 (132 KHZ). Jumper JP1 on the Controller selects which crystal frequency is in use. Position 1 (the upper position) selects crystal Y1. Position 2 selects crystal Y2, and position 3 selects Y3. (see Figure 4.8) Be sure to turn the unit off, and then back on when you are done changing the frequency. You must re-tune after changing the frequency.

The Controller and the Tx wand antennas will come from the factory set to Y2 (131.072 KHZ). This is the **primary** frequency and should be used whenever possible.

When two zones are close enough to “see” Tags activated in the other zone, you should implement alternate frequencies. Remember to cycle the power.

If you are dealing with 3 or more doors close together, you should stagger the frequencies so that the 131.072 KHZ (Y2) frequency is used most often (see Figure 4.9).

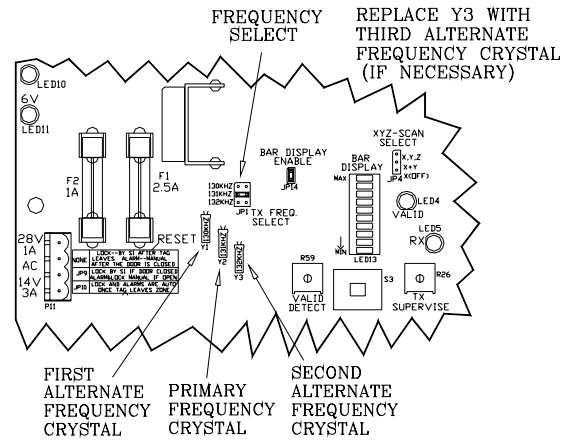


Figure 4.8 The Tx frequency crystals

Typically, you should not operate two doors on the same frequency when they are closer than 70 feet.

If you should need more than the 3 factory installed frequency crystals, contact your Accutech Representative about acquiring additional alternate frequency crystals.

Keep in mind whenever you change to an alternate frequency, you will need to re-tune the Tx wand antenna(s) (see page 4-7).

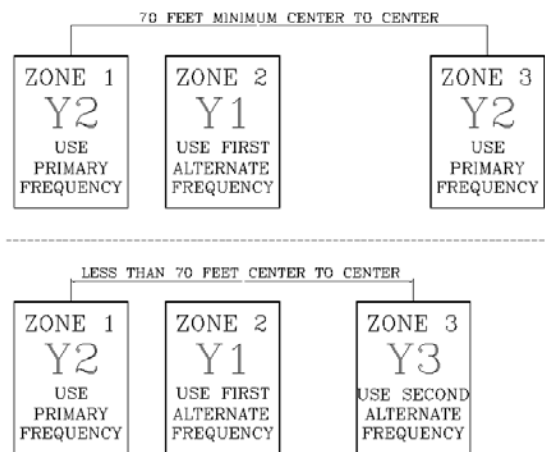


Figure 4.9 Alternating Tx Frequencies in nearby zones

Why Re-tune a Tx wand Antenna?

Tx wand antennas come from the factory set to Y2 (131.072 KHZ). Under most circumstances, they will not need to be adjusted. However, there are 3 possible reasons to re-tune:

- a. The antenna had to be mounted close to a metal object during installation and was detuned.
- b. Stagger Tuning is implemented.
- c. Someone has made an adjustment to the Tx wand antenna and you want to get it back to the factory setting.

Tuning a Tx wand antenna

A Tx wand antenna should only be adjusted during initial installation or for the reasons stated in the “Why Re-tune a Tx wand antenna?” section.

NOTE: Make sure all connections have been made as outlined in the previous sections.

In this manual, the term “potentiometer “ is often shortened to “pot” for simplicity.

IMPORTANT:

Tuning procedures can cause Supervise alarms. Notify staff and security that you will be adjusting (and possibly weakening) the zone and they will need to pay special attention to area traffic during this time.

Before you start

For either tuning method, before you start note the number of antennas in the zone and complete the following steps to establish a good starting point:

On the Controller:

- Verify JP14 (Bar Display Enable) is in place.
- Verify JP15 (Tx Output LED Enable) is in place.
- Adjust pot R6 (Tx Gain), clockwise to the maximum.
- Verify pots R4 (Y Balance) and R12 (Z Balance) are at their maximums (fully clockwise).
- Move Switch S3 to the *right* position.
- Verify JP1 (Tx Frequency Select) is in the correct frequency for the zone.
- Verify that the Supervise Threshold Level (the “flashing” green bar) is set at the second bar from the bottom on LED13 (Figure 4.10). If necessary, adjust pot R26 (Tx Supervise Threshold) to make it this way.

On each Tx wand antenna:

- Adjust pot R1 (LED Brightness) clockwise to the maximum

After completing the previous steps, refer to the appropriate section for your zone.

- One-antenna zone
- Two-antenna zone
- Three-antenna zone

One-antenna zone

To tune a one-antenna zone, refer to Figure 4.10 and use the following instructions:

- Using the spanner key provided or a spanner screwdriver, remove the antenna cover by removing the spanner screws.
- Remove the Controller cover by removing the cover screws.
- A “steady” and a “flashing” green bar should be illuminating on LED13. The “steady” green bar is the Tx Output Level and should be above the “flashing” bar but not off the top of the scale. The “flashing” green bar is the Tx Supervise threshold and should be at the second bar from the bottom on LED13.

NOTES:

You want to have the “steady” green bar as close to the top of LED13 as you can get it without going off the scale (Figure 4.10). Adjust pot R6 (Tx Gain) to make it this way. If the “steady” green bar is not present, then you need to turn down pot R6.

- On the antenna, adjust C1 until LED1 is as bright as you can make it (Figure 4.11).
NOTE: The object here is to use the brightness of LED1 to show when C1 has been adjusted properly. Therefore, if you try to see a change with LED1 set too bright you may miss that change and be slightly off tune. If this is the case, on the antenna, turn pot R1 (LED brightness adjust) counterclockwise until the yellow LED1 dims then adjust C1 again.

- After you have finished adjusting, on the antenna, turn pot R1 completely counterclockwise so that LED1 is dim.
- On the Controller, return switch S3 to the *left* position.
- Replace the antenna cover and secure it with the spanner screws.
- Replace the Controller cover and secure it with the screws.

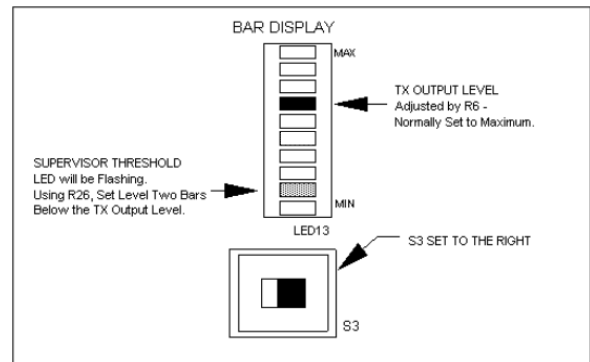


Figure 4.10
LED13 Tuning Mode (S3 to the Right)

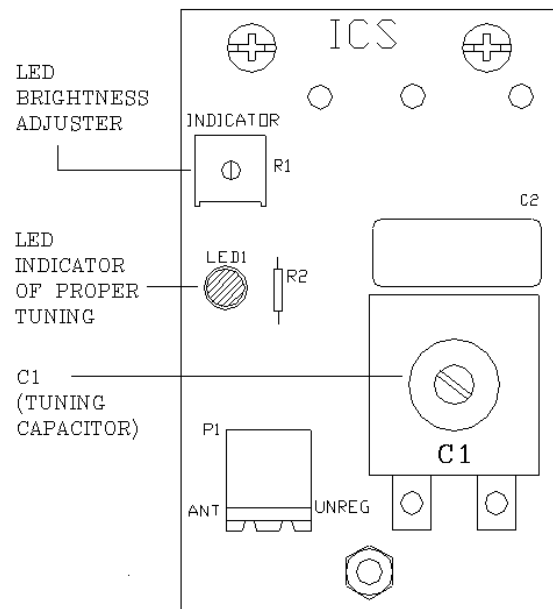


Figure 4.11 Tx wand antenna PCB

Two-antenna zone

To tune a two-antenna zone, refer to Figure 4.10 and use the following instructions:

1. Using the spanner key provided or a spanner screwdriver, remove both antenna covers by removing the spanner screws on each.
2. Remove the Controller cover.
3. A “steady” and a “flashing” green bar should be illuminating on LED13. The “steady” green bar is the Tx Output Level and should be above the “flashing” bar but not off the top of the scale. The “flashing” green bar is the strength of the Tx Supervise threshold and should be at the second bar from the bottom of LED13.
NOTES:
You want to have the “steady” green bar as close to the top of LED13 as you can get it without going off the scale (Figure 4.10). Adjust pot R6 (Tx Gain) to make it this way. If the “steady” green bar is not present, then you need to turn down pot R6.
4. Normally in two-antenna zones jumper JP6 (Scan Rate) alternates between illuminating LED1 and LED2 as it checks the “X” and “Y” antennas. For tuning two-antenna zones, you want to isolate one antenna at a time using jumper JP6. For these instructions we will start with the “X” antenna and then the “Y” antenna second.
5. On the Controller, quickly remove jumper JP6 (Scan Rate) so that only LED1 (the “X” antenna output indicator) is illuminating. This may take a few attempts. You will **not** leave the jumper in place while tuning.
6. On the antenna, adjust C1 until LED1 is as bright as you can make it (Figure 4.11).
NOTE: The object here is to use the brightness of LED1 to show when C1 has been adjusted properly. Therefore, if you try to see a change with LED1 set too bright you may miss that change and be slightly off tune. If this is the case, on the antenna, turn pot R1 (LED brightness adjust) counterclockwise until the yellow LED1 dims then adjust C1 again.
7. After you have finished adjusting, on the “X” antenna, turn R1 counterclockwise so that LED1 is dim.
8. Replace jumper JP6.
9. On the Controller, quickly remove jumper JP6 (Scan Rate) so that only LED2 (the “Y” antenna output indicator) is illuminating. This may take a few attempts. You will **not** leave the jumper in place while tuning.
10. On the “Y” antenna, adjust C1 until LED1 is as bright as you can make it (Figure 4.11).
NOTE: The object here is to use the brightness of LED1 to show when C1

- has been adjusted properly. Therefore, if you try to see a change with LED1 set too bright you may miss that change and be slightly off tune. If this is the case, on the antenna, turn pot R1 (LED brightness adjust) counterclockwise until the yellow LED1 dims then adjust C1 again.
11. After you have finished adjusting, on the “Y” antenna, turn R1 counterclockwise so that LED1 is dim.
 12. On the Controller, place jumper JP6 (Scan Rate) into position 1-2.
 13. On the Controller, return switch S3 to the *left* position.
 14. Replace both antenna covers and secure them using the spanner screws.
 15. Replace the Controller cover and secure it with the screws.

Three-antenna zone

To tune a three-antenna zone, refer to Figure 4.10 and use the following instructions:

1. Using the spanner key provided or a spanner screwdriver, take off all antenna covers by removing the spanner screws on each.
 2. Take off the Controller cover.
 3. A “steady” and a “flashing” green bar should be illuminating on LED13. The “steady” green bar is the Tx Output Level and should be above the “flashing” bar but not off the top of the scale. The “flashing” green bar is the Tx Supervise threshold and should be at the second bar from the bottom on LED13.
- NOTES:**
You want to have the “steady” green bar as close to the top of LED13 as you can get it without going off the scale (Figure 4.10). Adjust pot R6 (Tx Gain) to make it this way. If the “steady” green bar is not present, then you need to turn down pot R6.
4. Normally in three-antenna zones jumper JP6 (Scan Rate) alternates between illuminating LED1, LED2 and LED3 as it checks the “X”, “Y” and “Z” antennas. For tuning three-antenna zones, you want to isolate one antenna at a time using jumper JP6. For these instructions we will start with the “X” antenna, then the “Y” antenna second and finally the “Z” antenna.
 5. On the Controller, quickly remove jumper JP6 (Scan Rate) so that only LED1 (the “X” antenna output indicator) is illuminating. This may take a few attempts. You will **not** leave the jumper in place while tuning.
 6. On the “X” antenna, adjust C1 until LED1 lights *brightly* (Figure 4.11). **NOTE:** The object here is to use the brightness of LED1 to show when C1 has been adjusted properly. Therefore, if you try to see a change with LED1 set too bright you may miss that change and be slightly off tune. If this is the case, on the antenna, turn pot R1

- (LED brightness adjust) counterclockwise until the yellow LED1 dims then adjust C1 again.
7. After you have finished adjusting, on the “X” antenna, turn pot R1 completely counterclockwise so that LED1 is dim.
 8. Replace jumper JP6.
 9. On the Controller, quickly remove jumper JP6 (Scan Rate) so that only LED2 (the “Y” antenna output indicator) is illuminating. This may take a few attempts. You will **not** leave the jumper in place while tuning.
 10. On the “Y” antenna, adjust C1 until LED1 lights *brightly* (Figure 4.11).
NOTE: The object here is to use the brightness of LED1 to show when C1 has been adjusted properly. Therefore, if you try to see a change with LED1 set too bright you may miss that change and be slightly off tune. If this is the case, on the antenna, turn pot R1 (LED brightness adjust) counterclockwise until the yellow LED1 dims then adjust C1 again.
 11. After you have finished adjusting, on the “Y” antenna, turn R1 completely counterclockwise so that LED1 is dim.
 12. Replace jumper JP6.
 13. On the Controller, quickly remove jumper JP6 (Scan Rate) so that only LED3 (the “Z” antenna output indicator) is illuminating. This may take a few attempts. You will **not** leave the jumper in place while tuning.
 14. On the “Z” antenna, adjust C1 until LED1 lights *brightly* (Figure 4.11).
NOTE: The object here is to use the brightness of LED1 to show when C1 has been adjusted properly. Therefore, if you try to see a change with LED1 set too bright you may miss that change and be slightly off tune. If this is the case, on the antenna, turn pot R1 (LED brightness adjust) counterclockwise until the yellow LED1 dims then adjust C1 again.
 15. After you have finished adjusting, on the “Z” antenna, turn R1 completely counterclockwise so that LED1 is dim.
 16. On the Controller, place jumper JP6 (Scan Rate) into position 1-2.
 17. On the Controller, return switch S3 to the *left* position
 18. Replace all antenna covers and secure them using the spanner screws.
 19. Replace the Controller cover and secure it using the screws.

Alternate Tuning Method

WARNING: The following alternate tuning method requires more user knowledge about the Controller because it includes physically isolating each Tx wand antenna on the Controller during tuning.

NOTE: Make sure that all connections have been made as outlined in the previous section and you have completed the steps in the “Before you start” section on page 4-7.

To tune a Tx wand antenna, refer to Figures 4.11, and use the following instructions:

1. Using the spanner key provided or a spanner screwdriver, take off all antenna covers by removing the spanner screws on each.
2. Take off the Controller cover.
3. A “steady” and a “flashing” green bar should be illuminating on LED13. The “steady” green bar is the Tx Output Level and should be above the “flashing” bar but not off the top of the scale. The “flashing” green bar is the Tx Supervise threshold and should be at the second bar from the bottom on LED13 (Figure 4.10).

NOTES:

You want to have the “steady” green bar as close to the top of LED13 as you can get it without going off the scale (Figure 4.10). Adjust pot R6 (Tx Gain) to make it this way. If the “steady” green bar is not present, then you need to turn down pot R6. Turn off power to the system and:

- a. Disable the antenna X, Y, Z scan select by removing JP4. (If it is not already removed.)
- b. If this is a single antenna system, skip to Step 4.e. If this is a multi-antenna system, one by one, remove, mark and

tape the ends of the wires that are used in positions X, Y, & Z of the Controller's P1 connector.

- c. If this is not a 3 antenna system, skip to Step 4.d., otherwise, insert the wire that is marked "Z" into P1-pin2, or the "X" position, and tighten it. (Be sure that the "Unreg" wire is also connected.) Proceed to Step 5.
 - d. Insert the wire that is marked "Y" into P1-pin2, or the "X" position, and tighten it. (Be sure that the "Unreg" wire is also connected.) Proceed to Step 5.
 - e. Insert the wire for the X antenna into P1-pin2, or the "X" position, and tighten it. (Be sure that the "Unreg" wire is also connected.) Proceed to Step 5.
4. Turn on power to the system.
 5. On the Tx wand antenna PCB, adjust C1 until LED1 gets bright. If it gets very bright, re-adjust R1, so that it just turns on dimly.

NOTE: The object here is to use the brightness of LED1 to show when C1 has been adjusted properly. Therefore, if you try to see a change with LED1 set too bright you may miss that change and be slightly off tune. If this is the case, on the antenna, turn pot R1 (LED brightness adjust)

counterclockwise until the yellow LED1 dims then adjust C1 again.

6. Turn off power to the system.
7. If you have not been working with antenna "Z", go to Step 9, otherwise, loosen the terminal screw for position X and remove the Z wire from position X on the Controller's P1 connector. Return it to its normal Z position and tighten it. Go to Step 4.d.
8. If you have not been working with antenna "Y", go to Step 10, otherwise, loosen the terminal screw for position X and remove the "Y" wire from position X on the Controller's P1 connector. Return it to its normal Y position and tighten it. Go to Step 4.e.
9. If this is a multi antenna system, you need to replace JP4 (the X, Y, Z scan select jumper). It goes in the lower position, (2-3) for a two-antenna system. If you are using a three-antenna system place it in the upper position (1-2).
10. On the Controller, return switch S3 to the *left* position.
11. Replace all antenna covers and secure them using the spanner screws.
12. Replace the Controller cover and secure it using the screws.

Adjusting the Tx Activation Field

IMPORTANT:

Adjusting the Tx Activation Field can cause Supervise alarms. Notify staff and security that you will be adjusting (and possibly weakening) the zone and they will need to pay special attention to area traffic during this time.

The Tx Activation Field can be reduced or expanded to match each unique zone's needs. Each monitored zone may have circumstances that require an adjustment to the range of the Tx Activation Field. The most common reason is that the Field is overlapping or "bleeding" into other areas.

To adjust the range of the Tx Activation Field emanating from the Tx wand antenna *slowly* adjust potentiometer R6 (Tx Gain) on the Controller. Turn counterclockwise to *reduce* the range of the Field, turn clockwise to *expand* the range of the Field.

As you adjust, use a Tag to test the range of the Field to ensure there is adequate coverage for the zone.

Installation Manual

Chapter 5:

The Receiver

The Receiver

- Receiver Specifications
- Internal vs. External Receivers
- Receiver Mounting Options
- Receiver Positioning/Stagger Tuning
- BR 4200 Auxiliary Receivers
- Receiver Jumpers
- Connecting the Receiver
- Adjusting the Receiver

The Receiver (Figures 5.1-5.2) located at the monitored zone, picks up the signal from an activated Tag and relays it to the Controller. Zone Receivers can be internally or externally mounted near a monitored zone. BR 4200 Zone Receivers monitor both zone events and Band Removal events. BR 4200 Auxiliary Receivers only monitor Band Removal events.

NOTE: For ES 2100 Receiver information, see Appendix A.

Receiver Specifications

- Power Requirements
- Temperature
- Weight

Power Requirements

12V DC

Temperature

Receivers operate best in an ambient temperature between 35 and 90 degrees Fahrenheit. Operation outside of this range may cause unexpected or undesirable results, including premature failure.

Weight

Internal and External Receivers weigh approximately 5 oz. and 1 lb. 5 oz. U.S. respectively, which should be considered when choosing mounting hardware.

Internally Mounted Zone Receiver

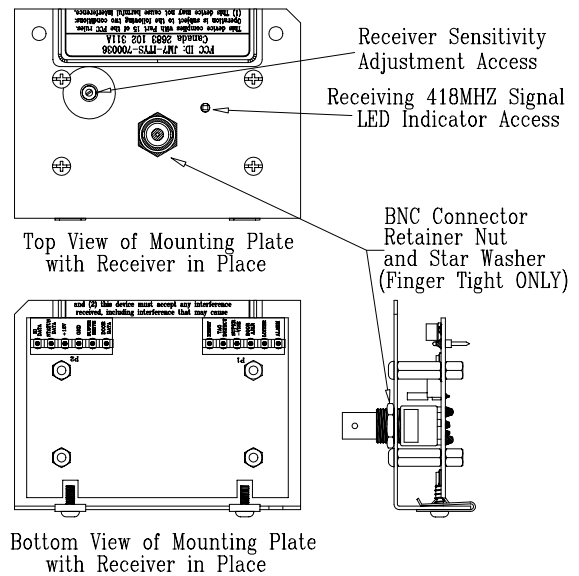


Figure 5.1 Zone Receiver (Internal)

Externally Mounted Zone Receiver

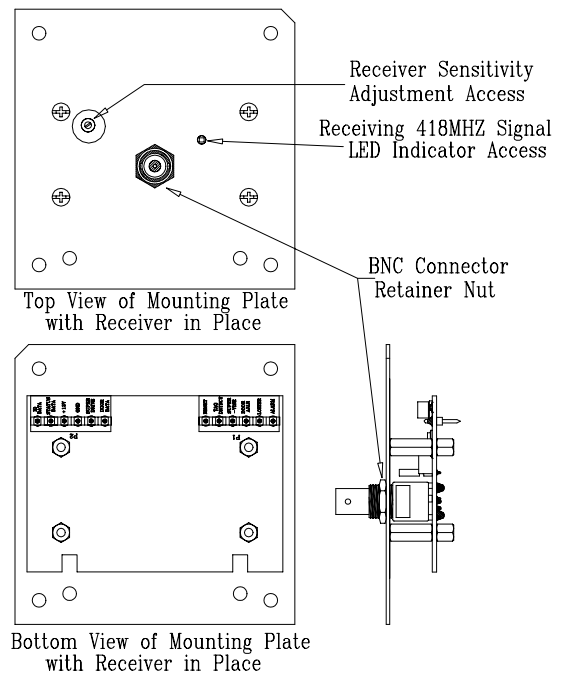


Figure 5.2 Zone Receiver (Remote)

Internal vs. External Receivers

When the Controller is positioned near the monitored door, the Receiver is mounted internally in the Controller housing.

When the Controller is positioned away from the monitored door, the Receiver is mounted at the zone in a 4"x4"x2" electrical box (Figure 5.3).

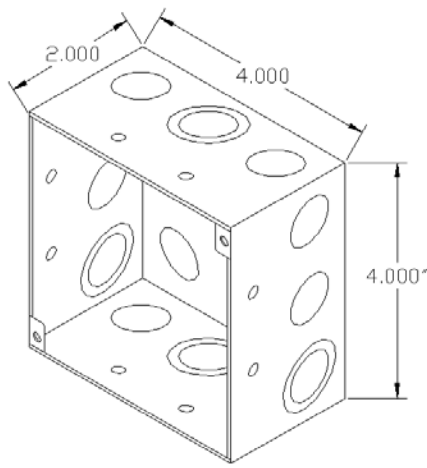


Figure 5.3 4"x4"x2" electrical box

Keep in mind when the Controller is remotely located, at least two 4"x4"x2" electrical boxes are needed at the zone. One box is used to mount the Receiver near the door as mentioned above and the second box is used as a junction box for the composite cable (where connections are made to wires that "branch" to the individual system components).

Receiver Mounting Options

If you receive your system equipment and determine that the Receiver needs to be changed from an Internal to External mounting or vice versa, contact your Accutech Representative about acquiring the proper faceplate.

Receiver Positioning/Stagger Tuning

Position the Receiver within approximately 6 feet of the center of the monitored zone or door opening. It is permissible to mount it beyond 6 feet, but do not exceed 15 feet from the center of the zone or door opening.

The recommended location for the Receiver unit is up and out of the way such as above the doorframe or above drop ceiling panels if possible. Receivers monitor 40 feet outward in every direction; therefore, they should be positioned approximately **70 feet** apart.

If the Receivers of adjacent zones need to be closer than 70 feet (Figure 5.4), implement Stagger Tuning (page 4-6) to avoid crosstalk (activated Tags from one zone being detected in another zone).

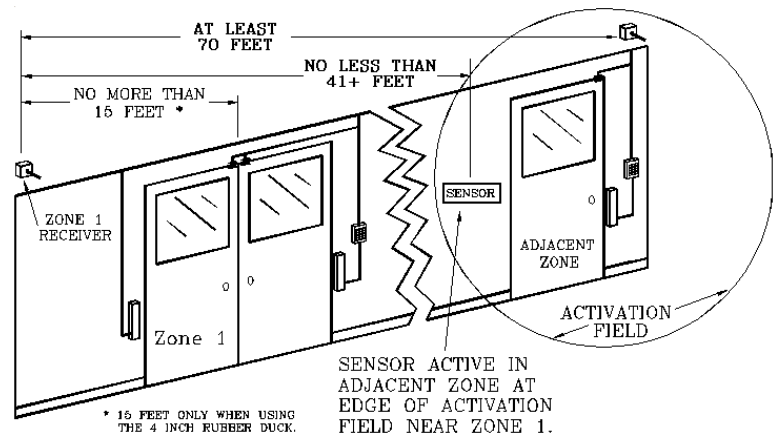


Figure 5.4 Receiver positioning

BR 4200 Auxiliary Receivers

BR 4200 Zone Receivers monitor both zone events and Band Removal events. BR 4200 Auxiliary Receivers only monitor Band Removal events. Depending upon your facility's physical layout, Zone Receivers may be enough to ensure full Band Removal coverage.

However, to determine where Auxiliary Receivers may be needed, a test BR42 Tag should be used to check every potential location in the area being covered. This includes storage rooms, laundry rooms, restrooms, etc. The idea is to be absolutely certain that there is no area where a BR42 Tag can be removed without being detected.

When installing BR 4200 Auxiliary Receivers, consider the following:

- BR 4200 Auxiliary Receivers are only used in BR 4200 Systems.
- BR 4200 Auxiliary Receivers are always mounted in 4"x4"x2" electrical boxes.

- Auxiliary Receivers require an external power source (+12V and GND; see page 17-5 for connections).
- Auxiliary Receivers monitor approximately 40 feet outward in every direction; therefore, they should be positioned **70 feet*** apart to avoid confusion about the location of a Band Removal alarm.
- Auxiliary Receivers can be positioned in nurseries, doorways, hallways, or any other area that coverage is desired (see Figure 5.5).
- When choosing the exact location and number of Auxiliary Receivers, be sure to consider the facility's structure (i.e., concrete/metal lathe as opposed to drywall walls or foil-backed ceiling tiles). Also keep a minimum distance of 4 feet away from fluorescent lighting and air ducts.

* The distances listed here are approximate. Each facility should consider its unique environment when positioning Receivers.

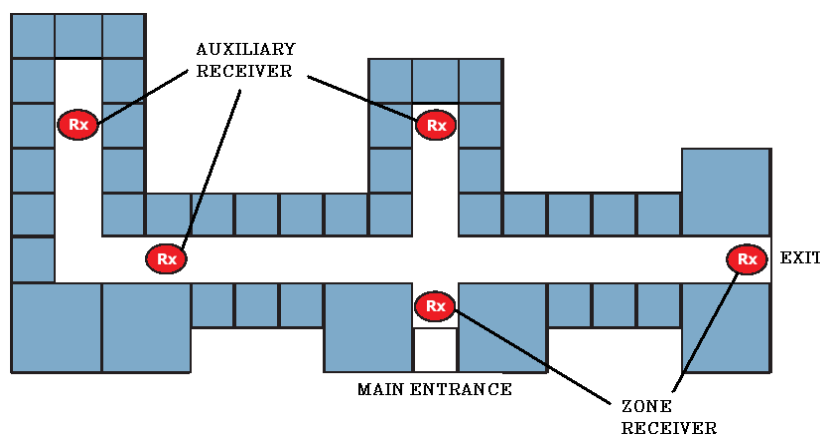


Figure 5.5 Receiver Positioning

Receiver Jumpers

- Jumper Definitions
- IS 3200 Zone Receiver jumper settings
- BR 4200 Zone Receiver jumper settings
- BR 4200 Auxiliary Receiver jumper settings

The following tables (Tables 5.1 – 5.4) contain the Receiver jumper definitions and default positions for each system. Refer to Figure 5.6 for the locations of the Receiver jumpers.

| Table 5.1 Jumper Definitions | |
|---|----------------------------------|
| Jumper | Sends Status Data Upon... |
| JP1 | Any 418MHZ Signal |
| JP2 | Rx Supervise Events |
| JP3 | Valid Zone Tag Detections |
| JP4 | Change in Tag status |
| JP5 | Zone Reset Events |

| Table 5.2 IS 3200 Zone Receiver jumper settings | |
|--|-----|
| JP1 | Off |
| JP2 | Off |
| JP3 | Off |
| JP4 | On |
| JP5 | On |

| Table 5.3 BR 4200 Zone Receiver jumper settings | |
|--|-----|
| JP1 | Off |
| JP2 | Off |
| JP3 | Off |
| JP4 | On |
| JP5 | On |

| Table 5.4 BR 4200 Auxiliary Receiver jumper settings | |
|---|-----|
| JP1 | Off |
| JP2 | Off |
| JP3 | Off |
| JP4 | On |
| JP5 | Off |

NOTES:

Receiver Jumpers JP1 through JP5 are set to factory defaults when you receive them. The default settings have been determined by the most common usage. Some facilities may have different requirements. Please consult your Accutech Representative before altering jumper positions.

Jumper JP4 sends status data upon a change in a Tag’s status. This includes Band Removal, Low Battery, and/or Wet Band.

Connecting the Receiver

Whether internally or externally mounted, the wire connections from the Receiver to the Controller are the same. See Figure 5.7 for the proper wire connections.

NOTE: The internally mounted Receiver is provided with a factory-installed interconnect cable. There should be no reason to ever disassemble it. If however it should need replacement for any reason simply use an 18-inch piece of 22 gauge 12-conductor non-shielded cable. Follow the color code in Figure 5.7.

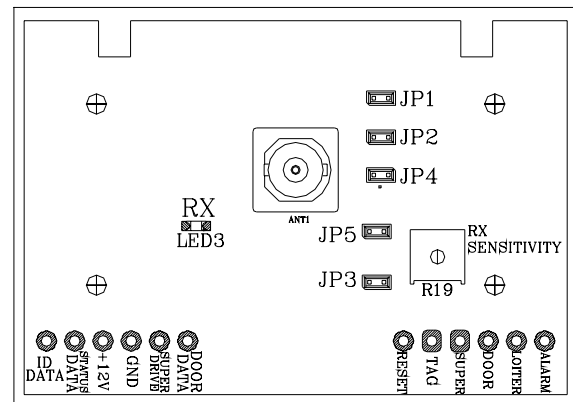


Figure 5.6 Receiver jumper locations

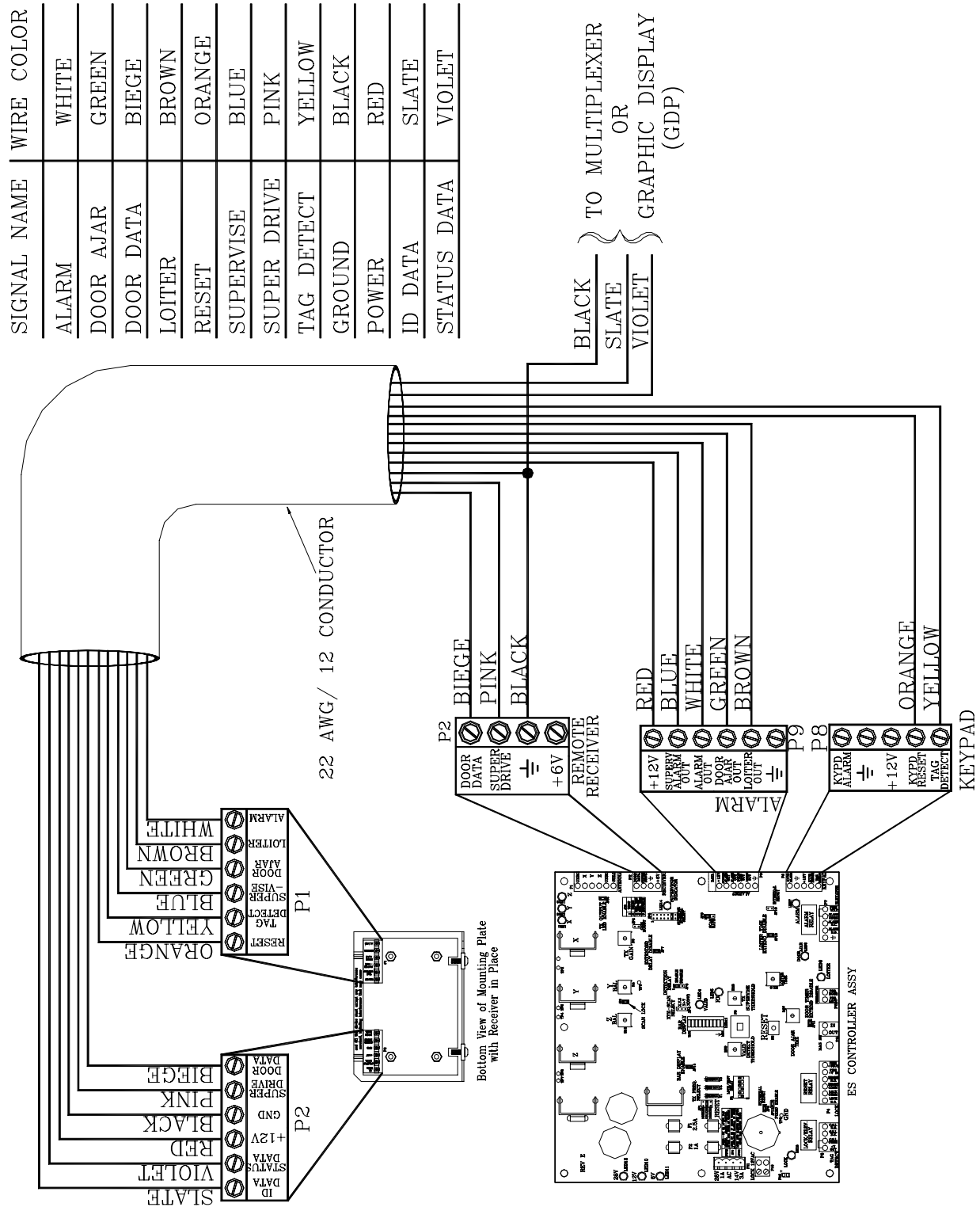


Figure 5.7 Connecting the Receiver to the Controller

Adjusting the Receiver

The Receiver is factory set for optimum performance, and as such, it should **NOT** be necessary for you to make any adjustments to it.

NOTE: If you are trying to eliminate crosstalk (activated Tags from one zone being detected in another zone), implement Stagger Tuning (page 4-6).

However, there are a couple of exceptions:

- When protecting a wide hallway or passageway, it may be necessary to increase Receiver sensitivity to assure optimum detection.
- When unavoidable background noise (such as from permanent medical equipment or wireless communication devices) is present, it may be necessary to reduce Receiver sensitivity.

IMPORTANT:

Adjusting the Receiver can cause Supervise alarms. Notify staff and security that you will be adjusting (and possibly weakening) the zone and they will need to pay special attention to area traffic during this time.

To adjust a Receiver, refer to Figure 5.1 or 5.2 and use the following instructions:

1. Around the access hole for potentiometer R19 on a Receiver, a decal marks the minimum and maximum settings. The factory setting is approximately halfway between the minimum and maximum marks. The Receiver will not work outside these marks. When adjusting, it is best to stay within 1/16" of a turn of the factory setting.
2. As you adjust, remember to verify that there is adequate zone coverage.
3. To *decrease* the Receiver's sensitivity, ***slowly*** turn potentiometer R19 clockwise toward the minimum setting on the R19 decal.
4. To *increase* the Receiver's sensitivity, ***slowly*** turn potentiometer R19 counterclockwise toward the maximum setting on the R19 decal.

Installation Manual

Chapter 6:

The Tag

BR 4200 System Tags

In addition to the functionality of an IS 3200 System Tag, BR 4200 System Tags (Figure 6.3) will alarm if the band is removed or tampered with in any way.

BR 4200 System Tags also contain a visual pulse LED. Tags are activated/deactivated with a TAD unit.

BR 4200 System Tags are attached to infants with a conductive-fiber-striped cloth band.

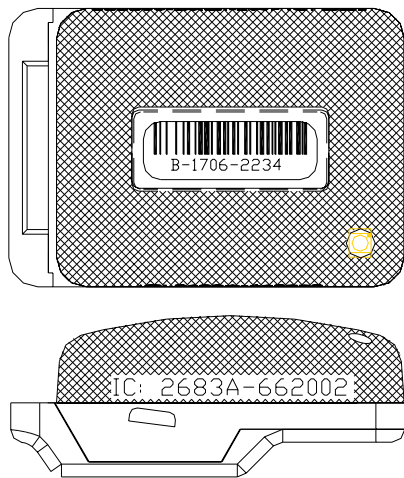


Figure 6.3 BR 4200 System Tag

Tag between applications and is water-resistant during use.

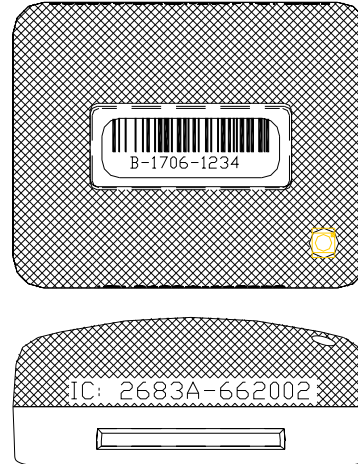


Figure 6.4 Cut Band Tag

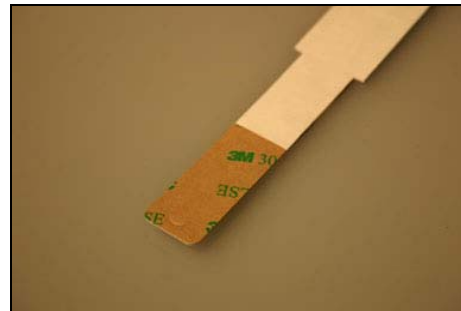


Figure 6.5 Cut Band Band

Cut Band Tags

Similar to the functionality of a BR 4200 System Tag, Cut Band Tags (Figure 6.4) will alarm if the band is cut and is designed for use in pediatric applications. Cut Band Tags also contain a visual pulse LED.

Cut Band Tags are attached to patients with a Tyvek band and a pod.

The band (Figure 6.5) contains a foil adhesive that will fray during tampering.

Using a pod (Figure 6.6) with a Cut Band Tag will reduce the need for sanitizing the

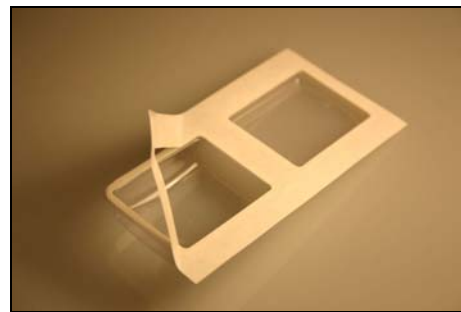


Figure 6.6 Cut Band Pod

LED Tag

- Verifying Proper Zone Coverage
- Identifying Foreign Tag-Activating Sources

DISCLAIMER: Due to each facility's unique environment, an LED Tag cannot give an *exact* measurement of zone coverage; it can only give an *estimation* of zone coverage.

Verifying Proper Zone Coverage

An LED Tag (Figure 3.8) is used to verify proper zone coverage during installation, adjustment, or testing of a monitored zone.

Proper zone coverage fully protects the intended area (door, elevator, hallway, or any other passageway) without extending into other areas (in front, in back, on sides, above, and beneath the intended area).

Monitored zones emit a Tag-activating signal called the Tx Activation Field. When a Tag enters a zone's Tx Activation Field, the system will detect the Tag and take appropriate action response.

An LED Tag can detect a zone's Tx Activation Field without causing alarms making it a quick and easy way to verify proper zone coverage. This is not only useful in ensuring complete zone coverage but also in locating areas where a Tx Activation Field may be extending into common areas and causing nuisance alarms.

To verify proper zone coverage with an LED Tag, use the following instructions:

1. Using a TAD, activate the LED Tag.
NOTE: The Signal Strength LEDs of the TAD will **not** indicate the state of the LED Tag. Once activated the LED Tag's LED will illuminate when it is in a Tx Activation Field. Therefore, to verify the LED Tag is active, turn on the TAD and place the LED Tag near it. The LED Tag's LED should illuminate (since a TAD has a small Tx Activation Field associated with it).
2. With the LED Tag in your hand, slowly approach each zone at various angles and orientations. The LED Tag's LED will illuminate when it detects the zone's Tx Activation Field.



Figure 6.8 The LED Tag

3. If you find that a zone's coverage is at unacceptable levels (too small, too big, extends too far in one direction), look for factors that may be affecting the zone (food carts, medical equipment, and/or building construction).
4. If you cannot locate any immediate causes, contact your system maintenance technician for further assistance.
5. When finished, deactivate the LED Tag using a TAD.

Identifying Foreign Tag-Activating Sources

In addition to verifying proper zone coverage, an LED Tag (Figure 3.3) can be used to identify foreign Tag-activating sources to help preserve your Tags' battery life and prevent nuisance alarms.

Monitored zones emit a Tag-activating signal called the Tx Activation Field. When a Tag enters a zone's Tx Activation Field, it is activated. The system detects the activated Tag and takes appropriate action response.

However, there are sources that can activate a Tag other than a Tx Activation Field. When Tags are activated by these "foreign" sources, battery life is depleted and/or nuisance alarms can be caused. Therefore, identifying these sources will prolong Tags battery life and prevent nuisance alarms.

To identify activating sources with an LED Tag, use the following instructions:

1. Using a TAD, activate the LED Tag.
NOTE: The Signal Strength LEDs of the TAD will **not** indicate the state of the LED Tag. Once activated the LED Tag's LED will illuminate when it is in a Tx Activation Field. Therefore, to verify the LED Tag is active, turn on the TAD and place the LED Tag near it. The LED Tag's LED should illuminate (since a TAD has a small Tx Activation Field associated with it).
2. With the LED Tag in your hand, slowly investigate each area for possible activating sources*. The LED Tag's LED will illuminate when it detects an activating source. Note each activating source and keep Tags away from those sources.
3. When finished, deactivate the LED Tag using a TAD.

*Some activating sources can be:

- Computer Monitors
- Unshielded computer cables
- Television Sets
- Medical Monitoring equipment
- X-ray and other imaging equipment
- Fluorescent Lighting
- Wireless Communication Devices

Testing Tags

For maximum protection of residents or assets, Accutech recommends that Tags be tested on a weekly basis.

There are 6 ways that you can test Tags:

- Enter a monitored zone (Software will report.)
- With a TAD
- With a PTAD
- The Keypad's Auxiliary LED (Yellow) will light when a Tag is detected (Optional; additional wire required).
- Check Visual Pulse LED if present
- BR and CB Tags only - Remove Band Removal band or Cut Band band (alarm will sound)

Tag and Band Maintenance

- Cleaning of Tags
- Cleaning of Bands
- Storage of Tags and Bands

Cleaning of Tags

All Tags are reusable but they **must** be cleaned and sanitized between applications.

In long-term applications, periodically replace the bands and clean the Tags.

There are a few methods that can be used to clean and sanitize Tags:

HOWEVER, DO NOT:

- **DO NOT** submerge Tags in water
- **DO NOT** soak Tags in water
- **DO NOT** submerge Tags in cleaning solutions
- **DO NOT** soak Tags in cleaning solutions
- **DO NOT** use solvents
- **DO NOT** use abrasive cleaners or cloths
- **DO NOT** put Tags in an *AutoClave*
- **DO NOT** put Tags in a dishwasher
- **DO NOT** steam clean Tags
- **DO NOT** put Tags in a washing machine or dryer

Acceptable Tag Cleaning Methods:

- Antibacterial wipes (wipe only, **DO NOT** soak)
- Hydrogen peroxide (wipe only from cloth, **DO NOT** submerge or soak)

Cleaning of Bands

All Tag bands are one-time use only. In long-term applications, periodically replace the bands and clean the Tags.

Storing Tags

To preserve battery life, Tags must be **turned off** with a TAD during storage or periods of non-use. CB and BR Tags **must** be deactivated to prevent alarms when not use.

However, if you do not have a TAD or your Tags are always activated, Tags should be stored away from sources of electrical noise (see below) and stored in a metal container with lid.

Furthermore, if you use a TAD to turn off your Tags, you would not necessarily need to follow the precautions listed above, however, it is still good practice to do so.

Do not store Tags within 3 feet of any of the following sources of electrical noise:

- Computer monitors
- Unshielded computer cables
- Television sets
- Medical Monitoring Equipment
- X-ray and other imaging equipment
- Fluorescent Lighting

Storing Bands

Extra Tag bands should be stored in clean and dry environment.

The S-TAD

- Powering the S-TAD On/Off
- Unlocking the S-TAD
- Activating/Deactivating Tags

The S-TAD (Secure Tag Activator/Deactivator) is used to check the functionality of an Accutech Tag. Accutech Tags operate by internal battery. Over the course of normal operation, Tags eventually lose battery power and the Tags will need to be replaced. The S-TAD is used to determine if a Tag has sufficient battery power to respond to an activating signal. The S-TAD requires a 9-volt battery to operate.

Powering the S-TAD On/Off

The S-TAD includes a built-in power saving feature that automatically turns off the S-TAD after a period of inactivity.

1. Press the Power/Clear button
The Power/Clear LED illuminates (solid **green** with wink).

The LED will remain lit for 1 minute. While nearing the 1 minute mark, the LED will begin to pulse until the LED turns faster pulsing **red** and then extinguishes while powering off the S-TAD.

To extend the length of time, press the Power/Clear button again anytime before the LED turns off. Each press will extend by 1 minute (up to 5 minutes maximum).

2. Conversely you may manually power off the S-TAD by pressing and holding the Power/Clear button until the LED turns solid **red**.

Unlocking the S-TAD

For added security, access to activating/deactivating Tags is locked via 4-digit user codes.

1. Press the Power/Clear button.
The Power/Clear LED illuminates (solid **green** with wink).
2. Using the number keypad, enter a valid 4-digit user code. Entering a valid code will illuminate the Enter LED (solid **green**) for about 5 seconds. Once the Enter LED illuminates, press the Enter button again. The WAIT LED will illuminate (**red**) for 2 seconds to confirm activation/deactivation action.

The Enter LED will then remain lit for 1 minute for the purpose of activating/deactivating Tags.

Notes:

- Entering an invalid code will illuminate the Enter LED red. Verify your user code is valid. Key Power/Clear before reentering code to clear any inadvertent previous entries
- Once lit, each time you press the Enter button will extend the Enter LED life briefly (up to 1 minute).
- Pressing the Power/Clear button will clear out the user code. Otherwise, after 1 minute of inactivity the Enter LED will extinguish automatically.

Activating/Deactivating Tags

The S-TAD can activate and deactivate Tags preserving Tag battery life and preventing nuisance alarms.

ACTIVATING

1. Unlock the S-TAD.
2. Place the inactive Tag in the correct orientation within the Tag receptacle. The Tag's graphic's LED is silent (just like the physical Tag's LED is silent).
3. Press the Enter button (**green** LED lit). The Wait LED will illuminate (**red**) for 2 seconds. The Tag graphic's LED on the S-TAD will illuminate (pulsing **yellow**) indicating the Tag is active (just like the physical Tag's LED will illuminate).
4. If a low battery condition is detected, the Low Tag Battery LED will illuminate **red**.
5. If a band alarm condition is detected, the Band LED will illuminate **red**. Likewise, if a band compromise condition is detected, the Band LED will illuminate **green/red**.
Note: Band alarm and/or band compromise conditions always take precedence over a low tag battery condition, therefore, be sure to handle the BR Tag appropriately to truly check for a low battery condition.
6. The S-TAD will still detect active Tags in the area even after the Enter LED extinguishes. However, you will have to unlock the S-TAD again to be able to activate/deactivate a Tag. Remember the S-TAD will automatically lock after 1 minute of inactivity.

DEACTIVATING

1. Unlock the S-TAD.
2. Place the active Tag in the correct orientation within the Tag receptacle. The Tag graphic's LED will be pulsing **yellow** (just like the physical Tag's LED will be pulsing).
3. Press the Enter button (**green** LED lit). The Wait LED will illuminate (**red**) for 2 seconds. The Tag graphic's LED on the S-TAD will extinguish indicating the Tag is deactivated (just like the physical Tag's LED will extinguish).

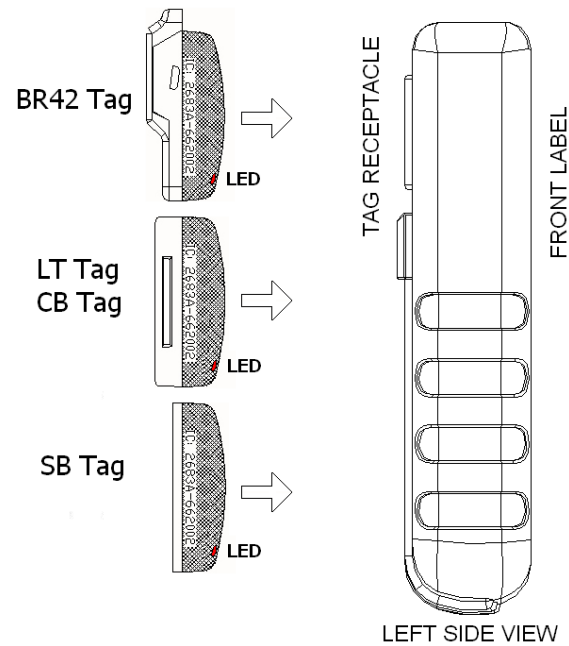


Figure 6.9 S-TAD Tag Orientation

Installation Manual

Chapter 7:

The Keypad

The Keypad

- Keypad Specifications
- Positioning the Keypad
- Surface Mounting the Keypad
- Flush Mounting the Keypad
- Connecting the Keypad to the Controller
- Programming the Keypad

The Keypad is used to escort residents through a monitored zone and to reset zone equipment once an alarm has occurred.

The Keypad provided by Accutech (*Visonic CL-8A*) is intended as an indoor Keypad only. If you require an outdoor Keypad, contact your Accutech Representative.

Keypad Specifications

- Power Requirements
- Temperature
- Weight

Power Requirements

12V DC @ 55 mA

Temperature

The Keypad operates best in an ambient temperature between 35 and 90 degrees Fahrenheit. Operation outside of this range may cause unexpected or undesirable results, including premature failure.

Weight

The Keypad weighs approximately 4.4 ounces.

Positioning the Keypad

The Keypad should be located within 3 to 5 feet of the monitored door or elevator. In hallway applications, mount the Keypad just outside of the zone to avoid alarm activation when escorting a monitored resident.

If your system includes the optional Push Button Override (PBO), it is recommended to mount it on the other side of the wall directly behind the Keypad.

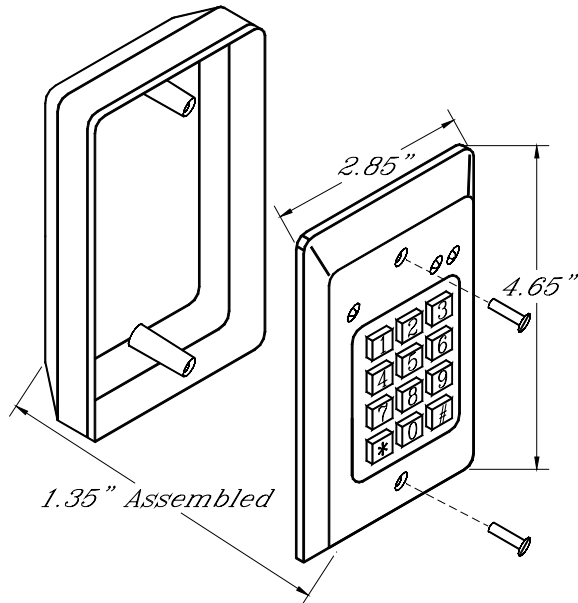


Figure 7.1 Surface Mounting the Keypad

Surface Mounting the Keypad

The Keypad is designed to be surface mounted using the white back box provided.

To surface mount the Keypad, refer to Figure 7.1 and use the following instructions:

1. Using a screwdriver, separate the Keypad from the white back box by removing the two screws.
2. If you are using wire molding, push or cut out the two knock-outs located on the top and bottom of the white back box for the wiring molding to interface with the white back box.
3. If you are running cable behind the wall, put or drill out the center knock-out in the white back box to wire from behind the wall into the white back box.
4. Drill out the four mounting knock-outs in the white back box.
5. If you have a PBO and plan to mount it on the other side of the wall of the Keypad, push or drill out the knock-out in the center of the back of the box.
6. Using the white back box as a template, mark all the holes that need to be drilled.
7. Drill the necessary holes in the mounting surface.
8. Secure the white back box to the mounting surface with appropriate hardware.
9. Replace the Keypad to the white back box using the two screws.

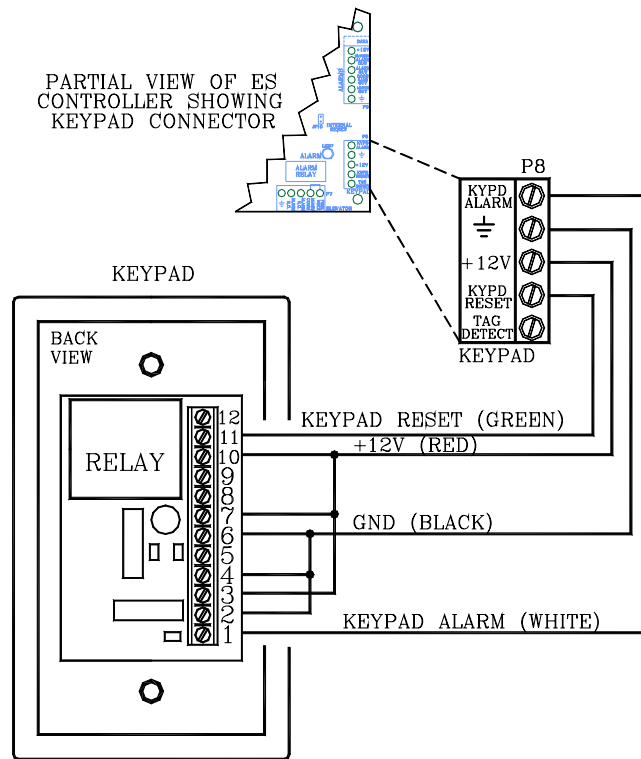


Figure 7.3 Connecting the Keypad to the Controller

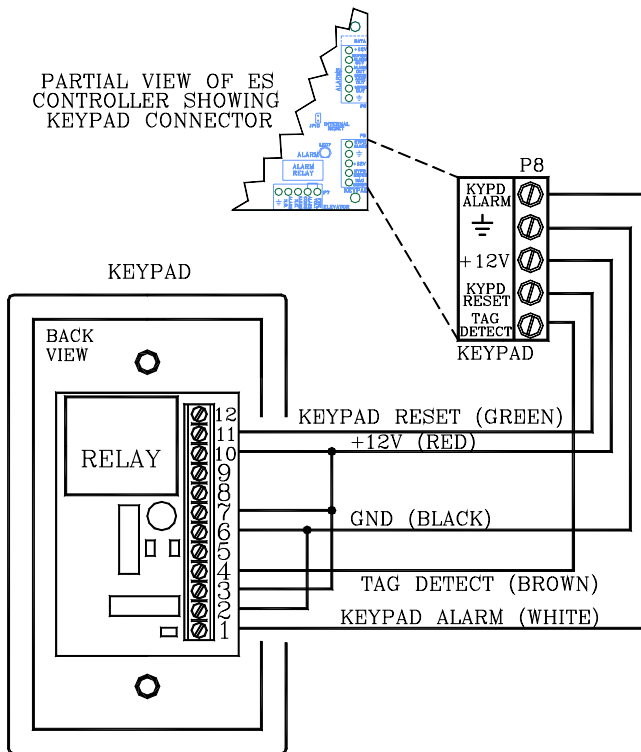


Figure 7.4 Connecting the Keypad to the Controller with Tag Detect option

Flush Mounting the Keypad

If flush mounting is required, use a plastic single gang electrical switch box, instead of the original white back box (see Figure 7.2). A flush mount box can be obtained from your local building supply outlet.

CAUTION: The Keypad manual shows the use of a standard single gang, metal electrical switch box. Accutech does **not** recommend the use of this type of box for two reasons:

1. The fit is very, very tight. If the wires are stripped a little “long” as they enter the terminal block they may short to the side of the metal box.
2. If this is not new construction and an electrical box with “zip” mounts is to be retrofitted in the wall, these zip mount tabs may actually protrude into the box and then it will be impossible to fit the Keypad circuitry inside the box.

If a metal box is required, you will need to find a single gang box fitting the dimensions indicated in Figure 7.2. You may find it easier to use a 4” square metal box and then use one of the many varieties of face plates available from your local building supply outlet that will accept the Keypad.

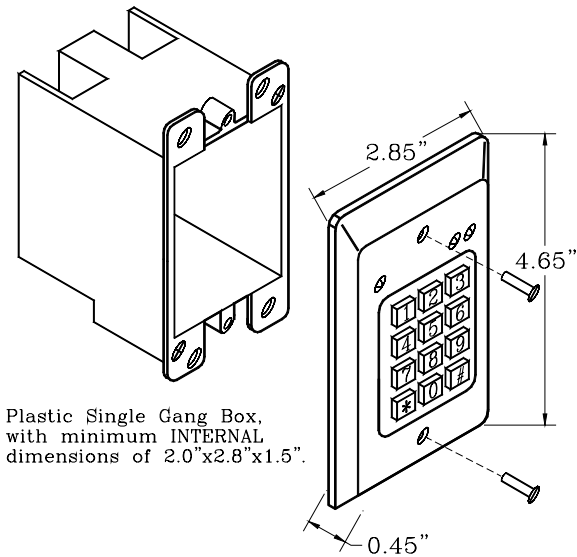


Figure 7.2 Flush Mounting the Keypad

Connecting the Keypad to the Controller

You will need 22-gauge 4-conductor plenum-rated cable for installation. If you are using composite cable, see Chapter 2 for color code.

If you are going to connect the Tag Detect signal to the auxiliary LED of the Keypad, you will need at least a 5-conductor cable.

To connect the Keypad to the Controller, refer to Figures 7.3 – 7.4 and use the following instructions:

1. Separate the Keypad from the white back box.
2. Remove the Controller cover.
3. Feed the cable from the Controller to the Keypad through the raceway, conduit, or wall and then through the access hole you made in the white back box.
4. With the WHITE wire, pin 1 of the Keypad to P8-pin1 (Kypd Alarm) of the Controller.
5. With the BLACK wire, connect pin 6 of the Keypad to P8-pin2 (Ground) of the Controller.
6. With the RED wire, connect pin 10 of the Keypad to P8-pin3 (+12v) of the Controller.
7. With the GREEN wire, connect pin 11 of the Keypad to P8-pin4 (Kypd Reset) of the Controller.
8. If you are using the **Tag Detect option (Figure 7.4)**, with the BROWN wire,

connect pin 4 of the Keypad to P8-pin5 (Tag Detect) of the Controller.

9. Place a jumper connecting the Keypad pins 2, 4 and 6.
NOTE: If using Tag Detect option, only jumper Keypad pins 2 and 6.
10. Place a jumper connecting the Keypad pins 3, 7 and 10.
11. Replace the Controller cover.
12. Replace the Keypad to the white back box.

Programming the Keypad

- Keypad Operation
- Programming user codes
- Deleting user codes
- Resetting the master code
- Adjusting the Keypad Escort Time

NOTE: In any Keypad operation, if any code is entered 3 times or more incorrectly, the Keypad will lockout for 90 seconds; this lockout mode is indicated by a green blinking LED.

Programming the Keypad is, in simple terms, providing it with a set of instructions on how to react in various contingencies. The Keypad must be programmed as soon as all installation and wiring have been completed. Later on, as changes take place, partial or full reprogramming may be carried out as many times as necessary.

The first step in “telling the Keypad what to do” is to access the programming menu, which is accessible only by the use of the current “master code”. The factory default master code is 1234, but after subsequent programming, this default code will be automatically superseded by user code No. 1, which becomes the real master code.

The Keypad’s EEPROM memory stores up to 56 individual access codes, each assigned to an authorized individual user or to a group of users.

CAUTION: User code No. 01, must be kept secret at all time to prevent the introduction of unauthorized changes in the Keypad’s programming. **Do not** use this code for normal entry into the restricted area.

Keypad Operation

The Keypad has three LED indicators. See Table 5.1 for their functions during normal operation.

Table 7.1 Keypad LED Indicators

| LED | Status | Function |
|---------------|--------|--|
| Green | Off | Zone Ready |
| | On* | Keypad Reset or Escort Time initiated |
| Yellow | Off | No Power or No Tag |
| | On | Power indicator or Tag in Zone indicator (dependant on installation) |
| Red | Off | Zone Normal |
| | On | Alarm |

*** During programming, the green LED functions differently.**

Programming user codes

Remember that user code No. 01 will become the new master code as soon as it is programmed, and therefore should be assigned to the person in charge of security.

It is recommended that the master code be composed of at least 8 digits.

To program user codes, use the following instructions:

1. Prepare a list of user codes you want to program and record them.
2. Invoke the programming menu by entering **, [master code], **. At this point we shall assume that the factory default of 1234 is still valid. When the programming menu is active, the green LED flashes slowly, approximately once every two seconds.
3. Press 1 to select user code programming (function No. 1).
The green LED begins to flash rapidly (approximately 5 times per second), indicating that the Keypad is ready to receive data.
NOTE: To prevent programming by unauthorized people, it is dangerous to continue using the default master code 1234. It is mandatory to set a new master code, which will be used for programming only and not for everyday requirements. We recommend that the master code be comprised of at least 8 digits.
4. Enter user number 01, followed by #.
The green LED lights steadily for two seconds and then returns to rapid flashing indicating that the step has been completed successfully.
5. Enter the code assigned to this user, followed by #.
The green LED lights steadily for two seconds and then returns to rapid flashing.
6. Repeat the user code followed by #. The green LED will acknowledge as in the step above.
7. Now select which outputs will be tripped by the new master code, select 3 for all outputs and then press #. This time the green LED lights steadily for two seconds and then flashes slowly, indicating that the new master code and its extent of control have been programmed successfully and that the Keypad has returned to the programming menu. Now you can either program the next user code or quit programming by pressing #.
8. Repeat these steps to assign other user codes.

NOTES:

Do not enter new data if the green LED responds by going out for 3 seconds after having pressed [#]. If the Keypad detects an error, the green LED turns off for 3 seconds and then returns to slow flashing, thus indicating that the data has not been accepted. It would be necessary to repeat the entire programming sequence for the rejected user code.

If you make an error while programming, press [*] and you will be instantly returned to the programming menu. To quit programming, ensure that the green LED is flashing slowly, then press [#]. This will restore the Keypad to normal operation.

Deleting user codes

To delete user codes, use the following instructions:

1. Access the programming menu by entering **, [master code], **. With the programming menu active, the green LED will flash slowly.
2. Enter 4 to select the user code deleting function.
The green LED will respond by flashing rapidly, indicating that the Keypad is ready to receive data.
3. Enter the user number whose code you wish to delete (02-56), or enter [**] to delete all user codes, and finish off by entering #.
The green LED will light steadily for 2 seconds and then will resume rapid flashing.
NOTE: The master code (User Code No. 01) cannot be deleted in this manner.
4. Enter the [master code] once more, followed by #.
The green LED will light steadily for 2 seconds and will return to slow flashing.

5. If you intend to delete another user code, return to step 2 above. If you are through deleting, restore the Keypad to regular operation by pressing # while the green LED is flashing slowly.

Resetting the master code

If you forgot or lost your master code (User Code No. 1), you can reset the Keypad to the factory default master code (1234).

To reset the master code to the factory default master code (1234), use the following instructions:

1. Open the Keypad's case to expose the printed circuit board.
2. Install the jumper across the two pins labeled JP2.
3. Momentarily short circuit the pins labeled JP1 using a screwdriver or jumper wire.
4. Wait ten seconds, remove the jumper from JP2, and immediately press 1234#. The green LED will light steadily for two seconds and then start flashing slowly, indicating that the programming menu is active.
NOTE: While the master code is reverted to 1234, all other data programmed previously remains intact.
5. Program a new master code (user code No. 1) immediately (see "Programming user codes section) and record it in a secret, safe place.

6. To quit programming at this stage, press # while the green LED is flashing slowly.

Adjusting the Keypad Escort Time

To adjust the Keypad Escort Time, use the following instructions:

1. Access the programming menu by entering **, [master code], **. With the programming menu active, the green LED will flash slowly.
2. Enter “2” to select the relay timer function.
The green LED will respond by flashing rapidly, indicating that the Keypad is ready to receive data.
3. Enter the escort time (two digits, from 1-98 seconds) followed by the # sign.
The green LED will light steadily for 2 seconds and then will resume rapid flashing.
4. To exit, press # while the green LED is flashing slowly.

