

TROUBLESHOOTING GUIDE

The following checks will assist in the correction of most problems which you may encounter with your set. Before going through the check list below, first check the following points.

The power cord must be connected firmly.

Should any problem persist after you have made these checks consult your nearest dealer

Symptom	Possible Causes (and Remedies)
RADIO RECEPTION	
No radio reception	The MODE selector has not been set to the correct position. Adjust the VOLUME knob. Rotate the TUNING knob to find a radio station. Switch the AUX IN jack to "OFF"
CD PLAYER OPERATION	
Disc does not play Or sound skips	Reload the disc with the label side up
	Clean the disc.
Sound skips	Change the installation location. Press the Reset button.
Unit is not working.	Press the STOP button and then program the tracks.
GENERAL	
Programmed disc play will not function	The AC power cord is not connected to an AC wall outlet. Check that the power cord is connected firmly. Push the power button from the "OFF" position to the "ON" position.
No sound output.	Turn VOLUME knob clockwise. Press the Reset button. Switch the AUX IN jack to "OFF" and remove the RCA cord. Switch the external speaker jack on the back cover.
Severe hum or noise.	The TV or VCR is too close to the stereo system. Separate from the TV or VCR.
Display garbled, non-functional.	Turn Off the power to restart.

THE OPERATING INSTRUCTIONS REFLECT THE CURRENT TECHNICAL SPECIFICATION OF THIS PRODUCT AT TIME OF PRINT.
WE RESERVE THE RIGHT TO CHANGE SPECIFICATIONS FOR TECHNICAL REASONS WITHOUT PRIOR NOTICE.

OPERATING INSTRUCTIONS

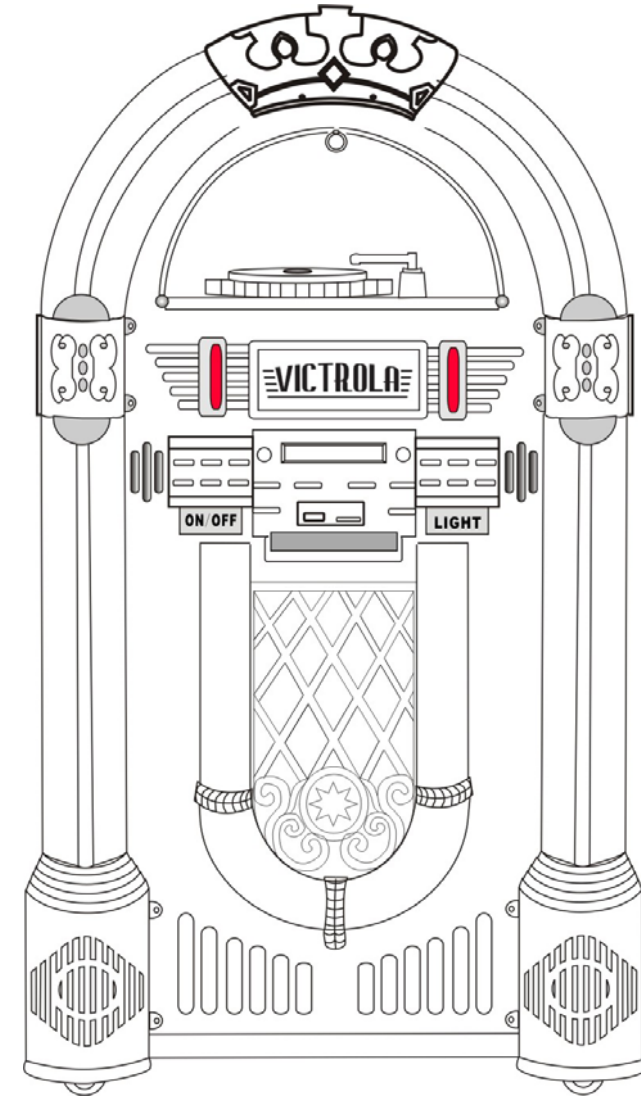

BYL-12: JUKEBOX-PHONOGRAPH

Jukebox **TIME STATION**



SAFETY INSTRUCTIONS

WARNING: TO PREVENT FIRE OR SHOCK HAZARD, DO NOT EXPOSE THIS APPLIANCE TO RAIN OR MOISTURE.



IMPORTANT SAFETY INSTRUCTIONS

1. Read instructions - All the safety and operating instructions should be read before the appliance is operated
2. Retain instructions - The safety and operating instructions should be retained for future reference.
3. Heed Warnings - All warnings on the appliance and in the operating instructions should be adhered to.
4. Follow instructions - All operation and use instructions should be followed.
5. Water and Moisture - The appliance should not be used near water; for example, near a bathtub, washbowl, kitchen sink, laundry tub, in a wet basement, or near a swimming pool, and the like.



Unit Specifications –

FREQUENCY RANGE: FM 87.5--108 MHZ

POWER SUPPLY: INPUT---100-240VAC ~ 50/60 Hz

OUTPUT---18V7A DC

POWER CONSUMPTIONS: 126 W

POWER SOURCE: REFER TO RATING LABEL AT BACK PLATE.

AUX IN and LINE OUT operation:

AUX IN- (If equipped with, please refer to the, otherwise, ignore) .

1. On the display lens "PH", under the condition of product on the back "PH/AUX " switch choose "AUX".
2. Plug the AUX in lead at the back of the juke box into your iPhone/iPod or other MP3 device. The AUX lead needs to be plugged into the earphone socket of your iPhone/iPod or other MP3 device.
3. Ensure line out switch at the back of the juke box is in the "AUX" position when using AUX in.
4. You can then begin playback from your iPhone/iPod or MP3 device. If you cannot hear anything, turn up the volume on the juke box.

Figure 4:

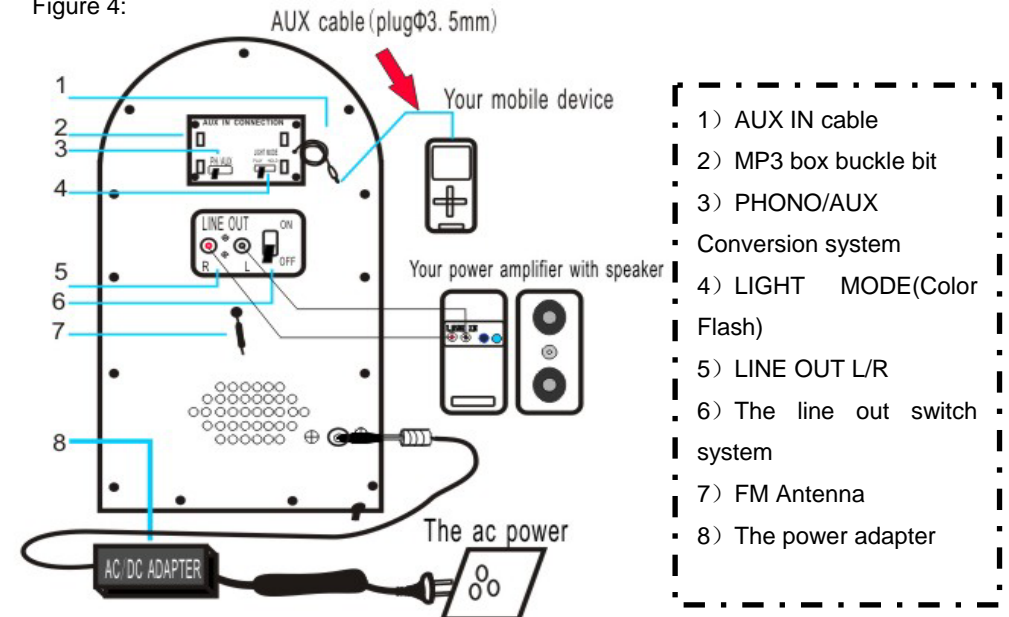

Note:AUX IN play music, need to make sure PHONO needle return back to needle on shelf.(Otherwise may be abnormal).

LINE OUT- (If equipped with, please refer to the, otherwise, ignore) .

1. "LINE OUT" switch system selection "ON".
2. Inserted the audio cable a jukebox "LINE OUT" jack, audio signal through the connection to an external amplifier device through the left/right channel. After the connection is successful, through the external power amplifier plays music.

TURNING ON THE LIGHTING EFFECTS

The Jukebox features 2 colour changing LED light tubes that are displayed on the Jukebox parts diagram as items figure 4-4. There are also several other multicoloured LED lighting effects that are featured in the CD player and USB/SD compartment and at the bottom of the speaker panel.

To turn on the LED lighting effects simply press the LIGHT button (No. 2-2 on the control panel diagram of 24). All the LED lighting effects will illuminate.

NOTE: The lighting effects operate independently of the POWER button (No. 2-2 on the control panel diagram). The LIGHT button controls The power to The lighting effects and The on The back of The machine.

On the rear of the Jukebox, there is an LED Light Mode Switch (Number 4 On the Jukebox with parts diagram item 4) , the Colour Changing LED Light Tubes will fade in and out of several different colours continuously. When set to **HOLD** mode the LED Light Tubes will be illuminated in only one colour. By switching to **PLAY** mode, the LED Light Tube will begin to cycle through the colours. By switching back to **HOLD**, different colours can be selected to display and hold (please note that these colours have been predetermined and may not be the exact same colour as the light tube was illuminated when switched to "HOLD" mode).

To turn **OFF** the lighting effects all together simply press the "**LIGHT**" button once again, and all lighting effects will no longer be illuminated.

Note: in the "hold" mode, there may be no visible light, is normal (need to adjust the switch).

6. The appliance should always be used or stored on a flat stable surface indoors.
7. Ventilation - The appliance should be situated so that its location or position does not interfere with its proper ventilation. For example, the appliance should not be situated on a bed, sofa, rug, or similar surface that may block the ventilation openings; or placed in a built-in installation, such as a bookcase or cabinet that may impede the flow of air through the ventilation openings.
8. Heat - The appliance should be situated away from heat sources such as radiators, heat registers, stoves or other appliances (including amplifiers) that produce heat.
9. Power Sources - The United States is 120 vac-60Hz; Japan is 100 vac-60Hz. Power-Cord Protection - Power supply cords should be routed so that they are not likely to be walked on or pinched by items placed upon or against them.
10. Power cords should be regularly inspected and if any damage is discernible then stop using and consult a qualified electrical technician.
11. This item is fitted with a 3amp fuse only.
12. Cleaning - The appliance should be cleaned only as recommended by the Manufacturer.
13. Non use Periods - The power cord of the appliance should be unplugged from the outlet when left unused for a long period of time.
14. Object and Liquid Entry - Care should be taken so that objects do not fall and liquids are not spilled into the enclosure through openings. Switch off immediately at power source if the item comes into contact with liquids and refer to a qualified electrical technician.
15. Refer to a suitable qualified technician if the appliance is damaged, needs servicing or has been dropped.
16. Servicing - The user should not attempt to service the appliance beyond general cleaning and changing of stylus.
17. This appliance / product is not intended for use by persons (including children) with reduced physical, sensory or mental capabilities, or lack of experience and knowledge, unless they have been given supervision or instruction concerning the use of the appliance by a person responsible for their safety. Children should be supervised so that they do not play with the appliance.

SETTING THE CORRECT TIME

➤ American :

version: When the Jukebox enters standby mode the LCD display panel will illuminate and the time "12:00" will appear on the LCD display panel.

➤ European version:

When the Jukebox enters standby mode the LCD display panel will illuminate and the time "00:00" .

● For example, the American version of the operation:

To set the time, simply press the "PROG" button on the control panel or remote control (No. 22 on the Control panel diagram or No. 6 on the remote control diagram) and hold this button down for 3 -5 seconds, until "12-H" is displayed on the screen ("12-H" indicates that the time will be set in 12 hour format),Then,press "NEXT" or "BACK" can choose 12 or 24 hour format;Once "12-H" is displayed on the screen press the "PROG" button again. The display will revert to "00:00" on the display, however, with the "12" flashing. Use the "NEXT" and/or "BACK" buttons on the control panel or the "PREV/F.R" and/or "NEXT/F.F" buttons on the remote control (No. 3 and 6 on the control panel diagram or remote control diagram), to select the correct hour (keep in mind it will be set it 12 hour time), then press the "PROG" button to confirm. The second "00" will now be flashing. Use the "NEXT" and/or "BACK" buttons or the "PREV/F.R" and/or "NEXT/F.F" buttons to select the correct minutes, then press the "PROG" button to lock this figure in.

NOTE: The time will only be saved in The Jukebox The when it is working or standby mode. If you wish to save the set time into your Jukebox, do not press the POWER button (No. 2 on the control panel diagram) to turn the unit off, simply press the ON/OFF button (No. 3 on the control panel diagram) to set the Jukebox to standby. If the POWER button (No. 2 on the control panel diagram) is used to turn the Jukebox off, it will erase the time setting and the above process will need to be repeated in order to reset the correct time the next time it is turned on.

- 7 Folder-: press to skip to the first track in the previous folder. If the Jukebox is in random ("RAN") mode the folder skipping function will be disabled.
- 8 Repeat: press to replay one particular song. press the button once repeating ONE song only, press the button twice repeating ALL the songs, press the button three times repeated RANDOM play.
- 9 Auto: press to Radio Auto-search and save stations
- 10 ST/Mono: Stereo / Mono Selection in Radio (where available)
- 11 PRE-: To playback previous stored radio station
- 12 MEM: tune the radio to the desired station The Jukebox has a 20 station memory to store the user's favourite radio stations.
In the condition of CD, CD door opening and closing.
- 13 PRE+: To playback a next stored radio station
- 14 EQ: To change the Equalizer setting equalizer settings preloaded on to the Jukebox are Pop (POP), Rock (ROC), Classical (CLA).and Flat (FLA), (To start the use of "POP" model for default) .
- 15 Folder+: press to skip to the first track in the next folder. If the Jukebox is in random ("RAN") mode the folder skipping function will be disabled.
- 16 NEXT/F.F: fast forward, press to go to the next track or fast forward through a track. You can then press the playback button to start playback.
- 17 VOL + : increase the voice, press the button repeatedly or press once and hold down until you reach the desired volume level.
- 18 Play/pause button: press to play or pause a track.

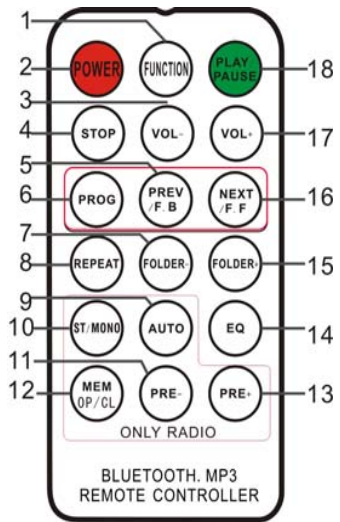

PROGRAM:

- While playing back from a music source, press the stop button.
- Press the program button to enter the program mode. The word PROG will flash in the bottom left corner of the display screen. A position number will also be flashing on the screen (eg: p01).
- Press the next or back buttons to select which track you want to program into position. When you have made your selection, press the program button to save it.
- You can then repeat the same steps to fill in more positions.
- When done, press play to begin your music playback. You can do this at any stage once you have programmed the amount of tracks you want.
- At any stage during the program process you can press stop to cancel.
- 'FUL' will display on the LCD screen when the Max amount of memory location have had been filled.

FUNCTIONS ON THE REMOTE CONTROL

- Function: To select between the different functions such as the FM tuner, CD player, USB input, SD input, Bluetooth and Phonograph.
- Power: the POWER button on the remote control diagram to exit standby mode and enter AM/FM Radio Mode.
- VOL - : reduce voice, press the button repeatedly or press once and hold down until you reach the desired volume level.
- Stop : press to stop a track.
- PREV/F.B(fast back): press to go to the previous track or rewind back through a track. You can then press the play button to start playback.
- Program: Allows you to program only particular songs of your choice to playback from your music source. (Further info on this function on the left upper corner of the page)

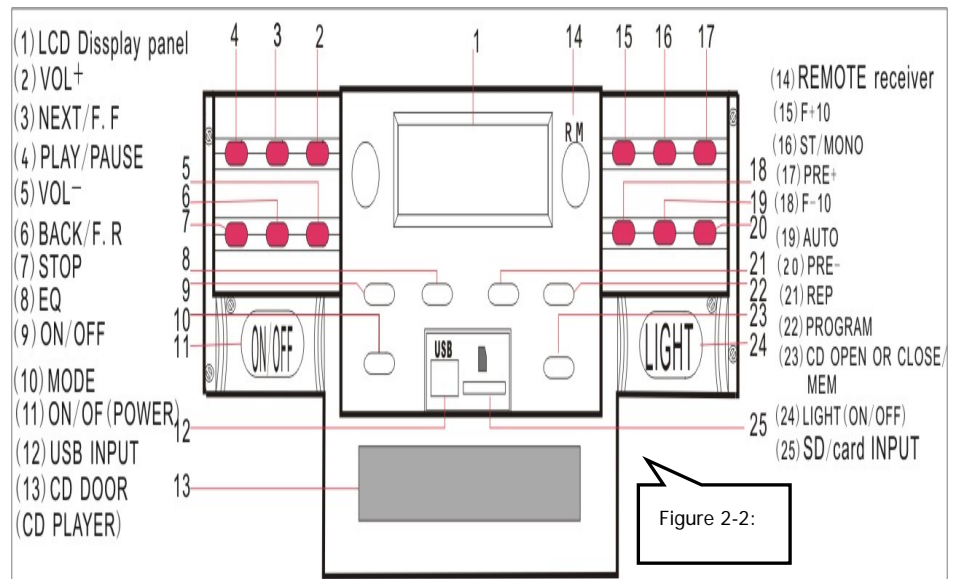
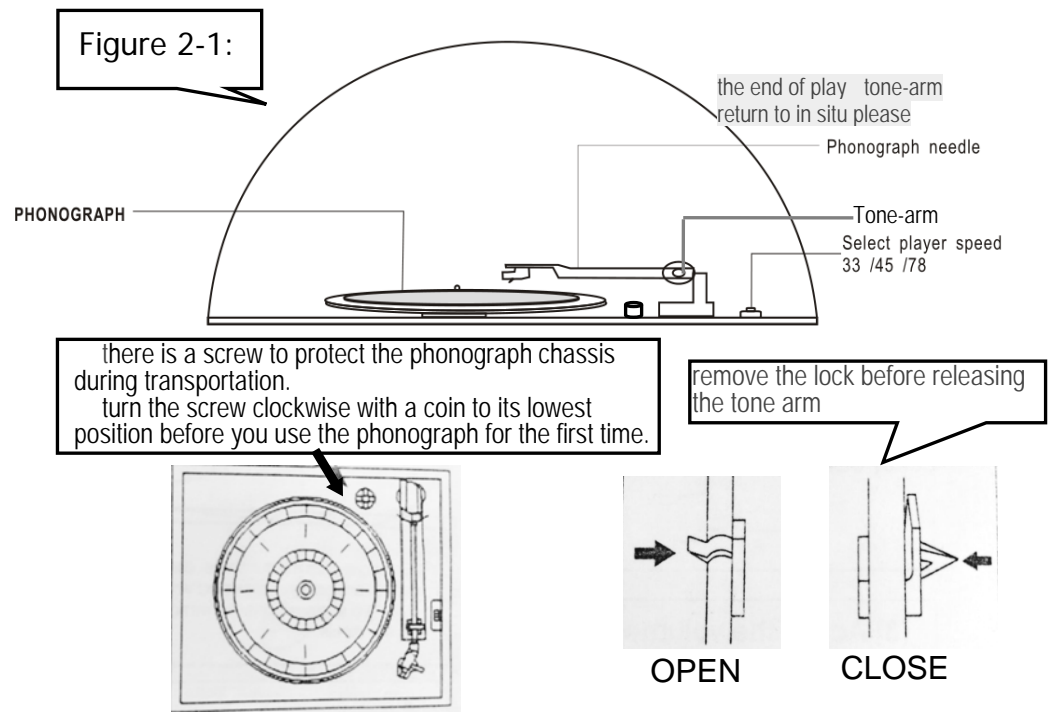

Figure 2-2:

1. Radio operation

This Jukebox features an inbuilt FM Tuner with auto-search function and a 20 station programmable memory. When using for the first time, press the POWER button and the Jukebox will switch to standby mode. Press the ON/OFF button on the control panel or the POWER button on the remote control to turn the Jukebox ON. The Jukebox should start in FM radio mode, the LCD display will show FM 87.5MHz and the speakers will emit a fuzzy sound (unless the frequency 87.5MHz contains a radio station in your area). If it does not automatically start in FM radio mode, press the MODE button on the Jukebox or the FUNCTION button on the remote control until FM radio mode is entered.

Note:

The American version of "FM" frequency, forward or backward, jumped 0.1 MHz; The European version of the "FM frequency, forward or backward, jumped 0.05 MHz; FM antenna, it needs long, put in the radio effect is the best location. (FM antenna in the back of the product).

2. CD operation (CD should be placed on the tray with the label side up)

- a. Press "MODE" button until led display indicate "- - - -", Press "OP - CL" button, CD door opening, Right into the CD, then display will show number of songs and then begin to start playback.
- b. Press "Next/F.F" to select your desire song.
- c. Press "REP" once to repeat one song, the REP indication at the top left corner on the led display will flash. Press "REP" one more time to repeat all songs in the track and the REP indication at the top left corner on the led display will appear. Press "REP" again to cancel repeat function.
- d. To play songs randomly, press "REP" button until the led display "RAN" on the bottom of the display.
- e. For programming, press "STOP" button to stop playback. Press "PROG" to enter programming mode. The led display will flash and indicate "P 01", select the song that you want to program and then press "PROG" again. Press "Play/Pause" to stop programming and start to playback the programmed songs. This unit can program up to 20 songs (Further info on this function on page 8) .

3. USB/SD operation.

- a. Press "Mode" button until led display indicate " USB - - - -", then display will show number of folder, then number of songs and start playback.
- b. Press "Next or Prev" or "F+/-10" to select your desire song.

- c. Press "REP" once to repeat one song, the REP indication at the top left

corner on the led display will flash. Press the "REP" display "REP FOLDER" repeat album; Press "REP" one more time to repeat all songs in the track and the REP indication at the top left corner on the led display will appear. Press "REP" again to cancel repeat function.

- d. To play songs randomly, press "REP" button until the led display "RAN" on the bottom of the display.
- e. For programming, press "STOP" button to stop playback. Press "PROG" to enter programming mode. The led display will flash and indicate "P 01", select the song that you want to program and then press "PROG" again. Press "Play/Pause" to stop programming and start to playback the programmed songs. This unit can program up to 20 songs.

4. To begin pairing with a Bluetooth device.

- 1) Press "MODE" button until LCD display "bLUE" and wait for 3 seconds to make the Jukebox speaker discoverable.
- 2) Turn on the Bluetooth device and let it automatically search for available Bluetooth devices.
- 3) From the Bluetooth device list, select the device named "JUKEBOX".
- 4) Once the pairing is completed, the Bluetooth will indicated "connected".

To start playback songs from your Bluetooth device. You can control from your Bluetooth device or from the Jukebox itself or remote control(provided).

- a. Control from the Bluetooth device. Use keys on the display to select songs, volume +/-, play/pause and next/prev function.
- b. Control from the Jukebox/remote control.
- c. Once pairing is completed, the song from the Bluetooth device automatically start to playback.f
- d. Press "VOL+/-" to control the sound level.
- e. Press "Next or PREV" to select next and previous song respectively.
- f. Press "PLAY/PAUSE" to pause or continue playback.
- g. To end the pairing, press "MODE" button to other functions or turn off the Bluetooth connection from the Bluetooth device.

5. Phonograph Record

Note: PHONO play music, need to make sure the product back "PH/AUX" conversion system selection "PH"(Switch on the back of the product position). If equipped with AUX IN, this switch operation, otherwise skip.

1. Press "MODE" button until led display indicate "PH", Put the phonograph record into the player, select player speed 33/45/78, the needle moved to the record above, began to playback(In the on page 5 -Figure 2-1) .
2. NOTE: the tone-arm will automatically return to the tone arm-rest after reaching the end of the record.

Warning:

This device complies with Part 15 of the FCC Rules. Operation is subject to the following two conditions: (1) this device may not cause harmful interference, and (2) this device must accept any interference received, including interference that may cause undesired operation. changes or modifications not expressly approved by the party responsible for compliance could void the user's authority to operate the equipment.

This equipment has been tested and found to comply with the limits for a Class B digital device, pursuant to Part 15 of the FCC Rules. These limits are designed to provide reasonable protection against harmful interference in a residential installation. This equipment generates, uses and can radiate radio frequency energy and, if not installed and used in accordance with the instructions, may cause harmful interference to radio communications. However, there is no guarantee that interference will not occur in a particular installation. If this equipment does cause harmful interference to radio or television reception, which can be determined by turning the equipment off and on, the user is encouraged to try to correct the interference by one or more of the following measures:

- Reorient or relocate the receiving antenna.
- Increase the separation between the equipment and receiver.
- Connect the equipment into an outlet on a circuit different from that to which the receiver is connected.
- Consult the dealer or an experienced radio/TV technician for help.

This device and its antenna(s) must not be co-located or operation in conjunction with any other antenna or transmitter. This equipment should be installed and operated with a minimum distance of 20 centimeters between the radiator and your body.