

DATASHEET

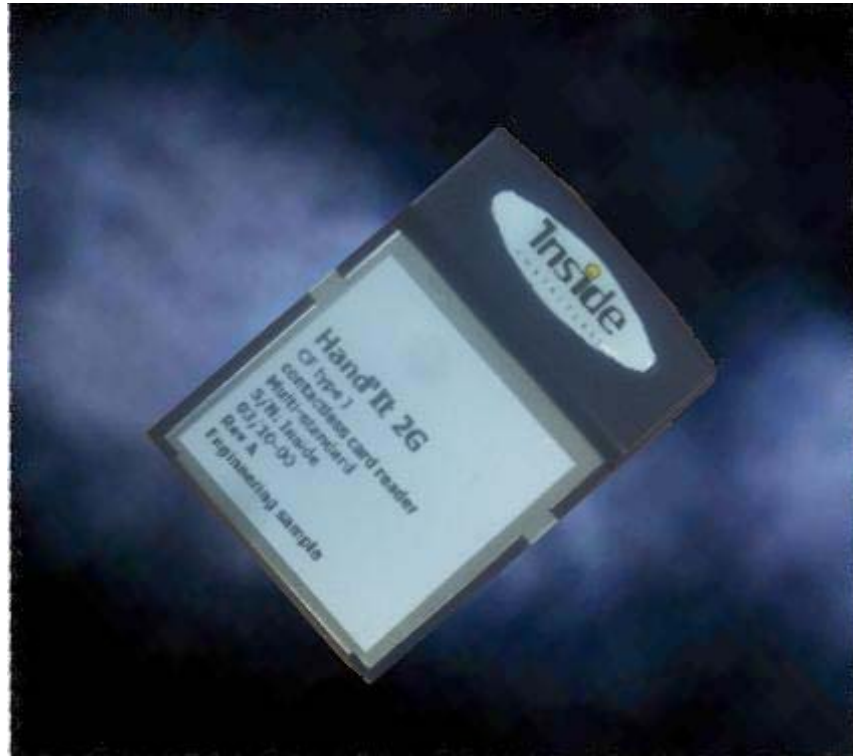

Hand'IT-2G Compact Flash READER

- 13.56 MHz for ISO chips**
- 14 443 type A and B
- 15 693
- FeliCa

[Chips](#) > [Packaging](#) > [Readers](#) > [more...](#)



Content

FCC AND CE COMPLIANCE	6
HAND-IT 2G Block Diagram	7

CHAPTER 1 HAND'IT-2G DESCRIPTION

HAND'IT-2G dimensions	8
<i>Mechanical Interface – Top View</i>	8
<i>HAND'IT-2G with PCMCIA Compact Flash Adaptor (not supplied)</i>	8

CHAPTER 2 HAND'IT-2G CONNECTION

<i>Physical Description</i>	9
<i>Electrical Description</i>	9
Power supply	9
<i>Characteristics</i>	9
	9
Software & Drivers	10
	10
Serial Interface	11
<i>Character Format</i>	11
<i>Baud rate</i>	11
How to reset HAND'IT-2G couplers	12
<i>Software reset</i>	12
<i>Hardware reset</i>	12

CHAPTER 3 COMMAND INTERFACE REFERENCE MANUAL

HOST - COUPLER protocol	2
<i>description</i>	2
Coupler commands overview	5
SELECT_CARD	6
SELECT_PAGE	8
TRANSMIT	10
GET_RESPONSE	12
READ_STATUS	13
SET_STATUS	14
<i>Modifiable parameters</i>	15
<i>Coupler's INPUTs AND OUTPUTS</i>	16
<i>EEPROM free area</i>	16
DISABLE_COUPLER	17

DISABLE_COUPLER ENHANCED	18
ENABLE_COUPLER	19
ASK_RANDOM	20
LOAD_KEY_FILE	21
SELECT_CURRENT_KEY	22
DIVERSIFY_KEY	23
GET_CONFIG	24

CHAPTER 4 USER'S GUIDE

Managing INSIDE chips	2
<i>Security configuration</i>	3
<i>Selecting a chip</i>	4
<i>Selecting a page</i>	5
<i>Reading chip memory</i>	6
<i>Writing chip memory</i>	7
<i>Halting a chip</i>	8
<i>How to work with several chips in the field</i>	9
Managing INSIDE's chips protocols	10
Managing the security	11
<i>INSIDE chips security</i>	11
<i>Key loading</i>	13
<i>How to set a key as the active one</i>	14
<i>How to authenticate a chip</i>	15
<i>How to authenticate a PAGE</i>	15
<i>Protecting the keys</i>	16
Managing STANDARD chips protocols	17
<i>Time out adjustment</i>	17
<i>15 693-3 protocol</i>	17
<i>ISO 14 443 type A</i>	18
<i>ISO 14 443 type B</i>	18
<i>FeliCa (new version)</i>	18
Managing the RF field	19
<i>How to reset the RF field ?</i>	19
<i>How to asleep the coupler</i>	19
<i>How to wake up the coupler</i>	19

APPENDIX A HOW TO LOAD A KEY IN A COUPLER

Exchange key	21
General key loading procedure	21
Terminology and notation	22
Key loading step by step	22

Algorithms	23
<i>Key permutation</i>	23
<i>Checksum byte calculation</i>	23
<i>Load key checksum calculation</i>	23

APPENDIX B ERROR CODE

Main Features

- √ **Security management:**
 - ☞ Security module
 - ☞ Secure key loading
- √ **Secured Key Storage**
- √ **Contactless interfaces:**
 - ☞ ISO 15 693
 - ☞ ISO 14 443 type A
 - ☞ ISO 14 443 type B
 - ☞ FELICA™
- √ **Contactless transmission of data and energy supply**
- √ **Carrier frequency: 13.56MHz**
- √ **On board antenna**
- √ **Transparent mode for contactless data exchange**
- √ **Supply voltage: 5 or 3,3V**
- √ **Low power consumption < 50 mA**
- √ **Idle mode < 5 mA**
- √ **Stand-by mode < 50 µA**
- √ **Small size: extended CF type I form factor (61 x 43 mm)**
- √ **Operating temperature range: -20°C to +50°C**
- √ **Emission approval* : FCC, IDA singapore, Canadian, CE**

Product Ordering Code

Product	Ordering code	Package	Tools
Proximity Coupler Hand'IT-2G	Hand'IT-2G/F	CF	-

FCC AND CE COMPLIANCE

Federal Communications Commission (FCC) Part 15 statement

This equipment has been tested to FCC requirements and has been found acceptable for use. The FCC requires the following statement for your information :

This equipment generates and uses radiofrequency energy and if not installed and used properly, that is, in strict accordance with the manufacturer's instructions, may cause interference to radio and television reception. It has been tested and found to comply with the limits for a Class B computing device in accordance with the specifications in part 15 of FCC rules, which are designed to provide reasonable protection against such interference in a residential installation. However, there is no guarantee that interference will not occur in a particular installation. If this equipment does cause interference to radio or television reception, which can be determined by tuning the equipment off and on, the user is encouraged to try to correct the interference by one or more of the following measures:

- If using an indoor antenna, have quality outdoor antenna installed
- Reorient the receiving antenna until interference is reduced or eliminated
- Move the radio or television receiver away from the receiver/control
- Move the antenna leads away from any wire runs to the receiver/control
- Plug the receiver/control into a different outlet so that it and the radio or television receiver are on different branch circuits.

This device complies with part 15 of the FCC rules. Operation is subject to the following two conditions : (1) this device may not cause harmful interference, and (2) : this device must accept any interference received, including interference that may cause undesired operation.

If necessary, the user should consult the dealer or an experienced radio/television technician for additional suggestions. The user or master may find the following booklet prepared by the Federal Communication Commissions helpful: «Interference Handbook». This booklet is available from the US Government Printing Office, Washington, DC 20402.

The user shall not make any changes or modifications to the equipment unless authorized by installation instructions or User's Manual. Unauthorized changes or modifications could void the user's authority to operate the equipment.



CHAPTER 1 HAND'IT-2G DESCRIPTION

HAND'IT-2G couplers are developed by INSIDE contactless for managing the RF communication interface with 13.56 MHz standard chips.

They have the following features :

- **Operating frequency** 13.56MHz
- **Host interface** CF card
- **Compatibility** Windows 98/XP/Me/2000/PPC2002-2003
- **Target applications** Proximity and short range applications
- **Target chip** All INSIDE's chips, 15693 chips, 14443 chips (type A and type B), FELICA™

Afterwards, the term «coupler» stands for an electronic board or device that converts numeric commands into contactless chip commands using the RF interface.

HAND-IT 2G Block Diagram

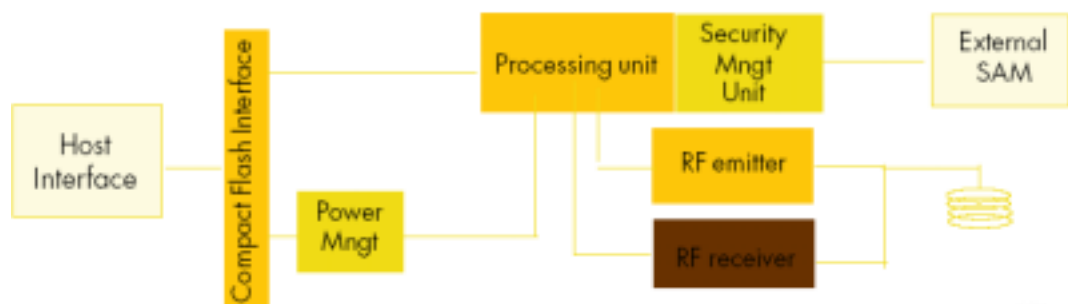

HAND'IT-2G dimensions

Mechanical Interface – Top View



- * HAND'IT size : L 61 mm * l 43 mm * h 3,3-8mm

HAND'IT-2G with PCMCIA Compact Flash Adaptor (not supplied)



CHAPTER 2 HAND'IT-2G CONNECTION

This chapter describes :

- ☞ How to power the coupler
- ☞ How to communicate with the coupler

Physical Description

The host is connected to the Compact Flash Hand'IT 2G using a standard 50pin connector.

The host must be equipped with a CF+ type 1 or 2 slot.

Refer to the host user manual for the Compact Flash card insertion.

Electrical Description

The HandIT 2G acts as a standard PC Card ATA using I/O Mode.

Refer to PC Card standards for details.

Power supply

CHARACTERISTICS

To power up the coupler, just insert the device into a CF type I or II slot.

Note that opening the associated COM port will power on the device and closing will Power it off.

Refer to the host operating system for more details.

<i>Description</i>	<i>Min.</i>	<i>Typical</i>	<i>Max.</i>	<i>Unit</i>
DC voltage	3,135	3,3	3,465	V
RF active current		50	TBD	mA
Idle Mode current		5	TBD	mA
Standby current		50	TBD	µA

Electrical characteristics

Software & Drivers

System requirements

The Hand'it 2G works with laptops or PDAs running Microsoft Windows 98/2000/XP/CE /Pocket PC2002&2003.

Pocket PC Users

PDA running Pocket PC don't need any specific driver to manage the Hand'IT 2G as a standard COM Port.

Depending on the device, the COM port number can take any value.

Refer to the Register DataBase to get the correct COM number under HKEY_LOCAL_MACHINE\DRIVERS\ACTIVE\xx

Search the Key with PnpId = Hand_It-INSIDE-D9A6

You will find the COM number in the *Name* Field.

Laptops users

You need to install the HandIT 2G drivers from the Inside installation disk

Insert the HandIT 2G into the laptop (using an CF to PCCARD adapter.).

Follow screen instructions and select the folder containing *HandIT2G.inf* file from the Installation Disk.

The HandIT 2G will appear as a standard COM Port named *Compact Flash HandIT*.

You can adjust COM settings from the hardware profil menu.

Coupler Communication

Once installed, the Hand'IT 2G works as a standard coupler connected to a serial COM port.

Serial Interface

This interface allows a serial connection to the host via the CF interface:

Character Format

<i>Data Rate</i>	115200 baud (default value)
<i>Parity</i>	Even
<i>Number of bits</i>	8
<i>Transmission Mode</i>	LSB first
<i>Stop bits</i>	2
<i>Flow control</i>	none

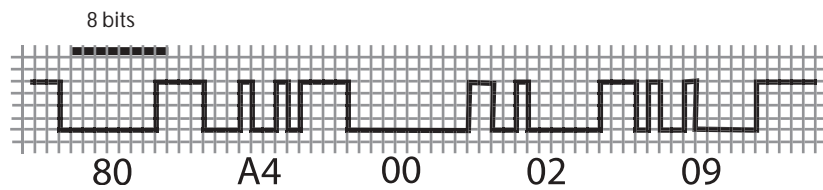

SelectCard command frame

Baud rate

The default data rate is set at 115200baud, but this can be changed by software to select following data rates :

- ☞ 9600
- ☞ 19600
- ☞ 38400
- ☞ 57600
- ☞ 115200

How to reset HAND'IT-2G couplers

Resetting the coupler may be useful in two situation :

- a. to set the parameters (speed, disable mode, protocol settings, keys) to the defaults values. All these values are stored in coupler's internal EEPROM
- b. if it is impossible to communicate with the coupler (bad setting for serial communication speed mainly)

SOFTWARE RESET

It is possible to reset the coupler's EEPROM by sending 2 commands thanks to the SET STATUS command.

Command = \$80,\$F4,\$80,\$3E,\$01 - Data = \$00

Command = \$80,\$F4,\$80,\$7E,\$01 - Data = \$00

Then the coupler has the default setting : 115200 bds, defaults protocols....

HARDWARE RESET

If for any reason it becomes impossible to communicate with the coupler, follow this procedure :

- remove the hand'IT 2G from the CF slot
- remove the plastic top cover as shown



- connect the 2 reset pins as indicated in the drawing



- reinsert the Hand'IT 2G and open the COM port: it will start with the default factory parameters
- remove the hand'IT 2G from the CF slot and the the reset pins connection

CHAPTER 3 COMMAND INTERFACE REFERENCE MANUAL

In this chapter you will find the command format, and the description of all the commands used by the coupler.

User may refer to this chapter to find the following information :

- ☛ *low level description of data exchange between coupler and host, mainly when using microcontroller or an automat*
- ☛ *check the signification and/or a value of a command parameter*

HOST - COUPLER protocol

DESCRIPTION

The commands are modeled on the ISO 7816 command set. This protocol is used by all INSIDE's couplers

A typical protocol exchange includes:

1. The host sends a command to the coupler
2. The coupler executes the command
3. The host receives a response from the coupler

Coupler command is always constituted of 5 bytes :

- CLASS : always 80h
- INSTRUCTION : command to be executed by the coupler (like SelectCard)
- P1 : Command parameter
- P2 : Command parameter
- P3 : Command parameter

Depending on the command, coupler answers data, status words.

There are 4 cases of data exchange:

Case	Host to coupler	Coupler to Host	ISO Type
1	None	None	ISO None
2	None	Yes	ISO Out
3	Yes	None	ISO In
4	Yes	Yes	ISO In / Out

Note : In case 4, data has to be sent and received from the coupler. With T=0 protocol, it is not possible in a single command, so this command has to be split into 2 commands:

ISO In : The host sends a command + data and receives the status words.
ISO Out : The host sends a command and receives data + the status words.

Coupler with firmware former than 40-017F has only ISO NONE, ISO IN and ISO OUT protocol available.

In all cases, status words are returned (SW1 and SW2).

Case 1: ISO None Data Exchange

	Command					Status words	
Host	Cl.	Ins.	P1	P2	P3		
Coupler						SW1	SW2
nb of bytes	5 bytes					2 bytes	

Case 2 : ISO Out Data Exchange - Coupler ⇨ Host

	Command					Ack.	Data	Status words	
Host	Cl.	Ins.	P1	P2	P3				
Coupler						= Ins.	data	SW1	SW2
nb bytes	5					1	= P3	2	

Class : always 80h

Instruction : command code

P1 & P2 : command parameters

P3: number of data bytes expected from the coupler

Ack. : coupler acknowledgement. It is always equal to the command code, except when an error occurs. If the Acknowledgement value is different than the instruction byte, then the received byte is the first byte of a status error code coded on 2 bytes.

Data : data sent to the host by the coupler. Size of the command has to be P3.

Status word : 90 00h if correct, error code.

Case 3: ISO In Data Exchange - Host ⇨ Coupler

	Command					Ack.	Data	Status words	
Host	Cl.	Ins.	P1	P2	P3		Data		
Coupler						= Ins.		SW1	SW2
nb bytes	5					1	= P3	2	

Class : always 80h

Instruction : command code

P1 & P2 : command parameters

P3: number of data bytes sent to the coupler.

Ack. : coupler acknowledgement. It is always equal to the command code, except when an error occurs. If Acknowledgement value is different than instruction byte, then the received byte is the first byte of a status error code coded on 2 bytes.

Data : data sent by host to the coupler. Size of data array has to be P3.

Status word : 90 00h if correct / error code.

Error : If the Acknowledgement value is different than the instruction byte, then the received byte is the first byte of a status error code coded on 2 bytes.

Case 4 : ISO InOut Data Exchange - Host ↔ coupler

	Command					Ack.	Data in	Ack.	Data out	Status words	
Host	Cl.	Ins.	P1	P2	P3		Data in				
Coupler						= Ins.		= Ins.	Data out	SW1	SW2
nb bytes	5					1	= P3	1	=P2	2	

Class : always 80h

Instruction : command code

P1 : command parameters

P2 : number of data bytes expected from the coupler.

P3 : number of data bytes sent to the coupler.

Ack. : coupler acknowledgement. It is always equal to the command code, except when an error occurs. If Acknowledgement value is different than instruction byte, then the received byte is the first byte of a status error code coded on 2 bytes.

Data : data sent to the host by the coupler. Size of the command has to be P3.

Status word : 90 00h if correct / error code.

Coupler commands overview

Command	INS	Description
SELECT_CARD	'A4h'	Selects one contactless card following list of possible cards in the field
SELECT_PAGE	'A6h'	Selects a page in a multi-application chip
TRANSMIT	'C2h'	Sends and retrieve data from chip through contactless interface : Transparent mode
GET_RESPONSE	'C0h'	Reads the internal buffer of the coupler to retrieve chip answer for ISO 7816 T=0 protocol.

Command	INS	Description
READ_STATUS	'F2h'	Reads coupler status or EEPROM memory.
SET_STATUS	'F4h'	Sets the coupler status or write in EEPROM memory.
DISABLE_COUPLER	'ADh'	Disables the coupler. it will only respond after a ENABLE_COUPLER command.
ENABLE_COUPLER	'AEh'	Enable the coupler. It wakes up the coupler after a DISABLE_COUPLER command.

Security module functions :

Command	INS	Description
LOAD_KEY_FILE	'D8h'	Load new master keys for authentication purposes.
ASK_RANDOM	'84h'	Ask for a random number from the coupler.
SELECT_CURRENT_KEY	'52h'	Select the key to be used for authentication purposes.

SELECT_CARD

Use

Select a card in order to get the serial number. This command manages anti-collision and authentication features.

This command is able to test several communication protocol. It answers the number of protocol used to select the card.

Prototyping

- * Command sent : A4h
- * Command type : ISO out

Host	80h	A4h	P1	P2	P3					
Coupler						A4h	Card type	Serial number	90h	00h

Parameters

Bit	7	6	5	4	3	2	1	0
Function	-	-	Key	Auth	Presel.	Loop	Halt	Wait

P1: Parameter used for contactless configuration

IMPORTANT: ' - ' are reserved for future use, and values should be set to 0.

WAIT :

- 1: Wait until a card is selected or a character received from the host (e.g. PC).
- 0: Exit if no card is detected after 3 attempts.

Note: When SELECT_CARD uses the option «LOOP», the coupler sends ACK=60h (See T=0 specifications) after each unsuccessful selection until a card is selected. When a card is selected, «90h 00h» is returned. In order to stop this scanning, host has to send a byte through the RS232 interface.

HALT:

- 1: Halts card after selection for fast serial numbers capture.
- 0: No halt after selection.

LOOP:

- 1: returned a frame composed of ACK | CARD TYPE | SN | 9000h or wait character 60h
- 0: no loop performed.

PRE:

- 1: Increases pre-selection with INSIDE CONTACTLESS anti-collision and a large number of cards.
- 0: Standard anti-collision (best for 5 cards max.).

AUTH:

1: Performs a standard INSIDE authentication.

Authentication is performed if the key is set as the current key.

Please refer to appendix A : «How to load a key» for key loading and key management operations details.

0: Does not perform an authentication.

KEY:

1: Authenticates with Debit Key (Kd = Key 1) if AUTH is set.

0: Authenticates with Credit Key (Kc = Key 2) if AUTH is set.

P2: Parameter used for selecting the card types to be read

b7 - b4	b3	b2	b1	b0
0	Protocol 3	Protocol 2	Protocol 1	Protocol 0

INSIDE couplers manage the following protocols :

- Protocol 0 : ISO 14 443 type B & Inside anticollision (only for INSIDE chip)
- Protocol 1 : ISO 15 693 & Inside anticollision (only for INSIDE chip)
- Protocol 2 : ISO 14 443 type B-3
- Protocol 3 : User defined protocol - see «Other ISO chip management» chapter for more information about Protocol 3 use.

If bit related to protocol x is set to one, coupler will run an anticollision using this protocol. If several protocols are selected, coupler will test all of them, starting from protocol 0 to protocol 3.

P3: Number of bytes to be return by the coupler

Set P3 = 09h for reading Pico Family Chips serial numbers.

Response: Card type (1 byte) and serial number (8 bytes)

Card type is the protocol number used by the card that has been selected for its answer. For 15 693 INSIDE's chips, card type value is 1 as protocol 1 is used for selection. This value is the one to use to indicate protocol in the transmit command.

SELECT_PAGE

Use

This command is used to select and authenticate in an INSIDE multi-application chip (8*2Ks...).

Prototyping

- * Command sent : A6h
- * Command type : ISO Out

Host	80h	A6h	P1	P2	08h					
Coupler						A6h	Chip 's configuration block	90h	00h	

Parameters

Bit	7	6	5	4	3	2	1	0
Function	-	-	-	-	Auth	Page selection	Protocol type	

P1: Parameter used for contactless configuration

b3 : Auth

- 0 - Does not perform authentication after PAGESEL.
- 1 - Performs authentication after PAGESEL

b2: Select Page

- 0 - Does not send the PAGESEL command before authentication
- 1 - Sends the PAGESEL command with page contained in P2 before authentication

Note : *b2=b3=0 imply that no operation is performed*

b1-b0: Protocol type:

This command can only work with PICO family chips

Contactless Communication Protocol

- 00 ISO14 443 B PICO family chips
- 01 ISO15 693 PICO family chips
- 10 ISO14 443 B-3
- 11 User's protocol

P2 : Page number to select and authenticate and cryptographic key to use

Bit	7	6	5	4	3	2	1	0
Function	Reader key number				-	Page number		

b7-b4 : Reader key number

Note : 0 correspond to Kd0, 1 to Kc0, ..., 14 to Kd7 and 15 to Kc7.

This is the reader key number to use during authentication. The reader will use this key number (EEPROM) to diversify and authenticate the requested page with Kd or Kc.

b3 : Page's key to use to perform the authentication

0 : authentication will be performed with page's debit key.

1 : authentication will be performed with page's credit key.

b2-b0 : Page number to select

P3 : Chip answer length

This parameter has to be set to 8 as the chip answers the page's configuration block (8 bytes).

TRANSMIT

Use

Transmits data from the coupler to the chip and read back chip response.
This command is the one to use to read and write data in the chip.

Prototyping

- * Command sent : C2h
- * Command type : ISO In / Out

Host	80h	C2h	P1	P2	P3		Data	
Coupler						C2h		Chip answer 90h 00h

P1 : Defines the contactless communication protocol

P2 : Chip answer length

P3 : Chip command and data

Parameters

P1: Parameter used for contactless configuration

Bit	7	6	5	4	3	2	1	0
Function	Send CRC	Check CRC	Time out		Send signature	ISO type	RF protocol type	

b7: Send CRC:

- 1: The coupler automatically sends the CRC (function of the Data bytes) to the chip. Coupler uses the CRC associated to the choosen protocol (bit 1 & 0)
- 0: Only P3 data bytes are sent.

b6: Compare CRC:

- 1: Compares the returned CRC with the expected value calculated by the coupler (verify the data sent by the chip).
- 0: CRC is not checked.

b5-b4: Time Out:

The time out value depends of the protocol used (b1 and b0 values).
The time out is the time from the command's EOF (End Of Frame) to the chip response SOF (Start of Frame).

Bits 4& 5	Time-out 15 693	Time-out 14 443
00	800 μ s	200 μ s
01	4 ms	1 ms
10	24 ms	6 ms
11	40 ms	10 m

b3: Send Signature:

1: Send a cryptographic signature calculated thanks to the coupler security module. This option may be used only for UPDATE command performed on secure PICO family chip. Set this value to 0 for non secure chip or any other manufacturer chips

0: Cryptographic signature is not sent.

b2 : HOST - COUPLER protocol type

1 : Communication is ISO IN-OUT. Coupler send back the data as soon as it receives chip answer.

0 : Commucation between HOST and coupler follows the ISO 78-16 T=0 protocol. Thus TRANSMIT command is only ISO IN, and user has to use the GET REPOSE command to retrieve chip DATA from the coupler.

b1-b0: Protocol type:

Defines the contactless communication protocol number to be used. When coupler's EEPROM is set with the default values, the protocol types are as follows:

Contactless Communication Protocol

00	ISO14 443 B PICO family chips
01	ISO15 693 PICO family chips
10	ISO14 443 B-3
11	User protocol (default value : ISO 14 443 A-3)

P2 : Number of data bytes received from the chip after transmission of the command.

If the Compare CRC bit of P1 is enabled, P2 should not include the CRC bytes.

Note: P2<=35 (23h).

P3 : Number of bytes in the data field of the command.

If the Send CRC or the Send Signature bit of P1 is enabled, P3 should not include the CRC bytes or the signature.

Note: P3<=32 (20h).

Data: Commands and data to send to the chip
All PICOTAG commands are detailed in PICOTAG datasheet.

Response:

- Chip answer
- Status word.

GET_RESPONSE

Use

This command returns the value contained in the internal buffer of the coupler. It has to be used to get chip answer when the TRANSMIT command is used with the ISO IN type to retrieve the chip answer.

Prototyping

- * Command sent : C0h
- * Command type : ISO out

Host	80h	C0h	00h	00h	P3				
Coupler						C0h	Coupler buffer	90h	00h

Parameters

P3: Number of bytes of the coupler response. It has to be less than 35 (23h).

Response : Coupler's buffer and status words

READ_STATUS

Use

This command is used to get coupler parameters (communication speed...).

Prototyping

- * Command sent : F2h
- * Command type : ISO out

Host	80h	F2h	P1	P2	01h				
Coupler						F2h	Read bytes	90h	00h

Parameters

P1: type of parameter to read

b7 - b2	b1 - b0
0 (RFU)	Parameter location

b1-b0 : Parameter location

- 00 : Parameter value is read in coupler's EEPROM (setting when power on)
- 01 : Coupler's I/O
- 10 : Reserved for Future Use
- 11 : Parameter value is read in coupler's RAM (current setting)

P2: set the parameter address to read

Valid values for P2 according to P1 value:

- EEPROM: 00h to FFh.
- I/O: 05h and 07h.
- Parameter: 50h to 6Fh.

Response : byte value at the transmitted address + status word

Note: When reading the I/O, the Read byte returned indicates the IN1, OUT1, OUT2 pin states as follows: (OUT2P is connected to VDD via a 1kΩ-resistor).

I/O Address	b7	b6	b5	b4	b3	b2	b1	b0
05h : Output	-	-	-	-	OUT2	OUT1	-	-
07h : Input	-	-	-	-	-	-	-	IN

SET_STATUS

Use

This command sets configuration parameters and coupler's I/O :

- * Communication speed
- * Protocols
- * State at Power ON
- * 2 outputs & 1 input

The various parameters and data used by INSIDE couplers are stored in the EEPROM. When coupler is powered on, a part of these parameters are load in coupler's RAM, so that parameters may be modified in coupler's EEPROM and in coupler's RAM. For a given parameter, RAM and EEPROM address are the same. For example, speed parameter is located at address 6Dh for both RAM and EEPROM.

☞ When updating a value in the coupler's EEPROM, this value will be the default value after turning the coupler on.

☞ When updating a value in the coupler's RAM, this value will be the current value until the next Power Off.

☞ When writing to EEPROM occurs, EEPROM parameters are reloaded into processor memory (RAM).

Prototyping

- * Command sent : F4h
- * Command type : ISO In

Host	80h	F4h	P1	P2	01h		Data	
Coupler						F4h		90h 00h

Parameters

P1: Sets the type of configuration parameter to update

b7	b6	b5-b2	b1 - b0
Reset coupler	Reset magnetic field	- (RFU)	Address

b7 : Resets coupler

if this bit is set to 1, coupler will fully reload EEPROM in RAM as if the coupler is powered on.

Note : when b7 = 1, the coupler responds 3Bh 00h.

b6 : Reset magnetic field

Magnetic field is cut for 20 ms.

When this bit is set to 1, coupler will execute no other action, including EEPROM or RAM update.

b5-b2 : RFU (reserved for future use)

b1-b0 : Parameter location

- 00 : Parameter value is read (written) in coupler's EEPROM (setting when power on)
- 01 : Coupler's I/O
- 10 : Reserved for Future Use
- 11 : Parameter value is read (written) in coupler's RAM (current setting)

P2: Sets the parameter address to update

Valid values for P2 according to P1 value:

- EEPROM : 00h to 07h and 3Eh to FFh.
- I/O : 05h, 06h, 07h.
- RAM : 50h to 6Fh.

Response: Status words

MODIFIABLE PARAMETERS

User can change the following parameters in coupler's memory :

- **Protocols** - Please refer to «Managing ISO protocol with INSIDE coupler» application note for more information about protocol management
- **Serial communication speed** - from 9600 to 424000 bauds depending on the reader

Name	Address	State	Hex. value	Available on...
Serial communication speed	6Dh	9600	57h	All readers
		19200	2Dh	
		38400	15h	
		57600	0Eh	
		115200	06h	

Note 1 : When updating the COMSPEED parameter, the coupler returns the Status Words with the previous COMSPEED before the COMSPEED update.

Example : the baudrate is set to 9600 bauds and needs to be temporarily updated to 115 200 bauds.

Send a SET_STATUS command (80h F4h 03h 6Dh 01h & 06h). The coupler responds (Status words) using 9600 bauds.

- **State at power on** - Is coupler emitting a field when it is powered on ? (please refer to ENABLE and DISABLE command chapters)

Name	Address	State	Hex. value	Available on...
State at power on	42h	Enable	01h	All reader
		Disable	00h	

Note 2 : The *ACTIVATE AT POWER ON* parameter defines the state of the coupler when you turn it on.

If you turn the coupler on and if 00h is written in the EEPROM at address 42h , it will be «asleep» until you send an *ENABLE_COUPLER* command.

IMPORTANT NOTE : If change in the *EEPROM* is followed by a reset of the coupler and if address 42h contains 00h then the coupler will be asleep until you send an *ENABLE* command.

COUPLER'S INPUTS AND OUTPUTS

Please refer to chapter 1 for connection.

Reader	Input / Output	I/O address	Command to use	Value
M21xH	OUT1	05h - Bit 1	Set Status	Bit at 0 : low level Bit at 1 : High level
	OUT 2	05h - bit 2	Set Status	
	IN 1	07h - bit 0	Read Status	
M22xH	OUT	05h - bit 2	Set Status	
M302H	OUT	06h - bit 4	Set Status	
ACCESSO	LED	05h	Set Status	Byte value & color 04h : Red 08h : Orange 0Ch : Green

EEPROM FREE AREA

User can use EEPROM bytes from 70h to 7Dh to write some data.

DISABLE_COUPLER

Use

The coupler goes in SLEEP mode that allows low power consumption and RF carrier is deactivated.

After this command, the coupler will not respond to any command except the ENABLE_COUPLER command.

A new feature available only on M21xH 2G is that coupler can detect if a card approach the antenna and wake up on its own.

Prototyping

- Command sent : ADh
- Command Type : ISO none

Host	80h	ADh	BCh	DAh	00h		
Coupler						90h	00h

Parameters

Response: **Status words**

Note : It is possible using the SET_STATUS command to have the coupler in a sleep mode each time it turns on. The coupler will then be asleep until you send an ENABLE_COMMAND. Please refer to the SET_STATUS command for activating this feature.

DISABLE_COUPLER ENHANCED

Use

As the DISABLE_COUPLER command, this specific version enables the user to asleep the reader.

But M210H 2G and M260H 2G have the possibility to detect that a card approaches their antenna.

As soon as the card is detected, the coupler will turn the RF field on, and start a card selection.

If no card answers to the anticollision process, the coupler go back asleep. If a card is selected, then the coupler stay awake.

Prototyping

- Command sent : ADh
- Command Type : ISO none

Host	80h	ADh	BCh	P2	01h		
Coupler						90h	00h

Parameters

P2 : specify the anticollision to process when a card is detected. If several bit are set at 1, all selected anticollision will be performed.

b7	b6	b5	b4	b3	b2	b1	b0
-	0	-	Pulse OUT1	Ant3	Ant2	Ant1	Ant0

- If Antx bit is set, then the anti-collision x will be processed else not.
- If no Antx is set, then the coupler will wake-up only by detecting a field change over the reader.
- If b4 is set, then the OUT1 PIN is set to high for 10 ms when a card is selected.

Note : It is possible using the SET_STATUS command to have the coupler in a sleep mode each time it turns on. The coupler will then be asleep until you send an ENABLE_COMMAND. Please refer to the SET_STATUS command for activating this feature.

Note : This command is only available on :
 - M210-2G
 - ACCESSO-2G

ENABLE_COUPLER

Use

This command restores a normal coupler running, with RF emission.
 This command can only be used after a DISABLE_COUPLER command or if the coupler is deactivated after power on.

Prototyping

- Command sent : AEh
- Command type : ISO none

Host	80h	AEh	DAh	BCh	00h	
Coupler						3Bh 00h

Parameters

Response : Status words

The coupler will respond «Instruction not recognized» (6Dh 00h) if already activated.

Important note : You have to send the **ENABLE_COUPLER** command in a window of 16ms. To be sure that your command will be received, send it twice. The time between the sending of the 2 commands has to be less than 10 ms.

This is automatically done when using MX.Enable method (ActiveX component).

ASK_RANDOM

Use

This command returns an 8 bytes random value from the coupler. This command has to be used to initialize the key loading procedure.

Prototyping

- * Command sent : 84h
- * Command type : ISO out

Host	80h	84h	00h	00h	08h				
Coupler						84h	Random number	90h	00h

Parameters

Response : Random number; Status words

LOAD_KEY_FILE

Use

This function loads into the coupler's security module a key to be used for authentication and security purposes.

Key loading is a security sensitive operation. In order to protect the confidentiality of the keys transferred to the coupler, data is encrypted. A 4-byte checksum is also sent in order to guarantee the authenticity of the data, which could be corrupted either through transmission errors or by a deliberate attempt to fraud the system.

Refer to «Coupler's key loading» chapter for more information about security and the way to calculate encrypted key and checksum.

Prototype

- Command sent : D8h
- Command type : ISO In

Host	80h	D8h	P1	P2	OCh		Data	
Coupler						D8h		90h 00h

Parameters

P1 : Parameter used for key operations

- 00: Load and activate the key pointed by P2.
 - 01: Deactivate the key pointed by P2 (Forbidden option to Exchange Key Ke).
 - 02: Delete the key pointed by P2 (Forbidden option to Exchange Key Ke).
- Others value are reserved for future use.

Notes:

With the 00 option, this command will replace the old value of the key with the new value.
 With the 01 and 02 options, the command has to be sent with 12-byte data at any value (Data = XX XX XX XX XX XX XX XX XX XX XX XX).
 When a key is deactivated, you need to reload it to reactivate the key.

P2 : Key number.

- 00h - Exchange Key Ke: used for key loading operation.
- 01h - Debit Key Kd0
- 02h - Credit Key Kc0
- 03h - Debit Key Kd1
- 04h - Credit Key Kc1
-
- 0Fh - Debit Key Kd7
- 10h - Credit key Kc7

Data:

This field contains:

- the 8-byte encrypted master key
- the 4-byte checksum

Response: Status Words

SELECT_CURRENT_KEY

Use

This function allows to choose a key for future authentications. A key that has been deactivated or deleted cannot be selected. Only one of the 16 keys can be current at the same time.

Prototype

- Command sent : 52h
- Command type : ISO In

Host	80h	52h	00h	P2h	08h		8 * 00h		
Coupler						52h		90h	00h

Parameters

P2 : Key number

- 01h - Debit Key Kd0
- 02h - Credit Key Kc0
- 03h - Debit Key Kd1
- 04h - Credit Key Kc1
-
- 0Fh - Debit Key Kd7
- 10h - Credit key Kc7

Remark: if the specified key is deactivated, the status bytes returned is 6Bh 00h.

DIVERSIFY_KEY

Use

This function enables the user to calculate the result of key diversification with selected chip serial number.

The key diversified value is used for authentication and signature calculation while writing a secure chip.

This can have 2 uses :

- before an authentication (SELECT_PAGE or AUTHENTICIFY command)
- to calculate the keys that will be written in a chip during a personalization phase (only working with a dedicated personalization coupler)

Prototype

- Command sent : 52h
- Command type : ISO In

Host	80h	52h	00h	P2h	08h		Chip serial number	
Coupler						52h		90h 00h

Parameters

P2 : Key number

- 01h - Debit Key Kd0
- 02h - Credit Key Kc0
- 03h - Debit Key Kd1
- 04h - Credit Key Kc1
-
- 0Fh - Debit Key Kd7
- 10h - Credit key Kc7

Remark: if the specified key is deactivated, the status bytes returned is 6Bh 00h.

GET_CONFIG

Use

This command is used to read the ID of the MCU part.

Prototype

- Command sent : CAh
- Command type : ISO In

Host	80h	CAh	00h	00h	09h					
Coupler						CA	ID (8)	Code Info (1)	90h	00h

Parameters

Data : MCU part's ID

Code Info (1 byte) : RFU

CHAPTER 4 USER'S GUIDE

In this chapter ou will learn how to use the coupler
to...

- ☞ Use INSIDE chip
- ☞ Manage the security

MANAGING INSIDE CHIPS

The various steps in INSIDE's chips management are the following :

- ☛ **Set the used key (if your application is secured)**
- ☛ **Select a chip**
- ☛ **If it is a multi-application chip, select the page in which you want to work**
- ☛ **Read, Write data in the chip memory**
- ☛ **Halt the chip to enable another chip selection**

Using INSIDE couplers, authentication and signature calculations are managed automatically by the SELECT_PAGE or the SELECT_CARD command. Just indicate in these commands that you want to use the security features.

In this chapter is just indicated the way and the functions and commands to use to reach your goal. Please refer to the Reference Manuals for more information about the functions and its parameters.

In this chapter you will also learn :

- ☛ **how to manage the various protocol at low level or with the activeX component**
- ☛ **how to make a chips inventory and select a chip within several ones.**

SECURITY CONFIGURATION

Before using the security features, please take a look at the «**Security management**» chapter. You will find there basic principles on which is based INSIDE chips security.

If your application is secured, you have to ...

a. Load the key in the coupler. This operation has to be performed only once. As soon as keys are loaded, they are stored in the coupler's EEPROM.

b. tell to the coupler which key you want to use for your application (Kd1, Kc1, Kd2 ...)

a. Loading the key...

You have to indicate the following parameter :

- Exchange key to enable you to load the key
- New key value
- Key number (is it «Debit Key 3», «Credit key 2»)

- ☛ **ActiveX :** [Mx.KeyLoading](#) method
- ☛ **C Library :** [CLib_w_KeyLoading](#) procedure
- ☛ **Low level :** **LOAD_KEY_FILE** command

b. Activating the current key...

Two commands are available to tell to the coupler which key you want to use. One has to be used before the selectcard command, and the other before the SelectPage or Authenticate command if you want to use a key different than the one used to authenticate the chip (or if you selected the card without authentication).

Use the following commands before the *SelectCard* command :

- ☛ **ActiveX method :** [Mx.CurrentKey](#) property
- ☛ **C Library :** [CLib_w_SelectCurrentKey](#) procedure
- ☛ **Low level :** **SELECT_CURRENT_KEY** command

Please refer to the chapter «Managing the security» for more details about the way it works, and to the reference manual chapter for more details about the commands.

Use the following commands before the *SelectPage* and *Authenticate* commands :

- ☛ **ActiveX method :** [Mx.DiversifyKey](#) property
- ☛ **C Library :** [CLib_w_DiversifyKey](#) procedure
- ☛ **Low level :** **DIVERSIFY_KEY** command

Please refer to the chapter «Managing the security» for more details about the way it works, and to the reference manual chapter for more details about the commands.

SELECTING A CHIP

During this operation, you will choose the protocol you want to use (14 443 type A, 14 443 type B or 15 693), and if you want to authenticate the chip. The answer will give you the protocol used by the chip, and its serial number

Security...	P1 value	Which protocol...	P2 value
none	00h	14 443 B-2	01h
Kd authentication	30h	15 693	02h
Kc authentication	10h	14 443 B-3	04h

Then use the following command :

- ☛ **ActiveX method :** *Mx.SelectCard* (P1, P2, Type_SerialNumber)
- ☛ **C Library :** *Clib_w_SelectCard* (P1, P2, Type_SerialNumber)
- ☛ **Low level :** **SELECT_CARD** : 80h A4h P1h P2h 09h...

Note 1 : Coupler will answer the protocol number used to communicate with the chip, and the chip serial number. This «protocol number» is the value to use with the TRANSMIT command as «protocol value»

Note 2 : The above table show 2 protocols ISO 14 443 type B

☛ **14 443 type B-2 :** RF protocol is the one defined in the 14 443 B standard level 2, and anticollision is INSIDE contactless one.

☛ **14 443 type B-3 :** RF protocol follows the 14 443 B standard level 2, and anticollision is defined in 14 443 B standard level 3.

SELECTING A PAGE

If you are using a Multi-application chip (8*2K for example) you have to select the page in which you want to work.

The SelectCard command selects by default page 0. The SelectPage command enables you to work in all other pages. It will manage the authentication if the page is secured.

You have to enter...

- page number
- key to use for authentication
- protocol to use

You will get...

- page configuration block (block 1)

Then use the following command :

☛ **ActiveX method :** *Mx.SelectAuthPage* (Key number, PageNumber, ConfigBlock)

☛ **C Library :** *Clib_w_SelectAuthPage* (Key number, Protocol, PageNumber, ConfigBlock)

☛ **Low level :** **SELECT_PAGE**

Host	80h	A6h	P1	P2	08h					
Coupler						A6h	Chip 's configuration block	90h	00h	

The following table gives you parameters to select and authenticate a secured page. P2 values are just examples.

Protocol	P1 value...	Page & key number	P2 value...
14 443 B	0Ch	Key Kd1 & Page 1	21h
15 693	0Dh	Key Kc1 & Page 1	31h
14 443 A	0Eh	Key kd7 & Page 7	E7h

Note : if the page is secured, use the diversify command to select in the coupler the key that will be use for the authentication.

READING CHIP MEMORY

You will find a full memory description in the chip datasheet, but the easiest way to discover the chip memory is to use the MX3 software (PICO MEMORY page).

You have to enter...

- block number
- protocol to use

You will get...

- memory data

Then use the following command :

☛ **ActiveX method :** ***Mx.ReadBlock*** (BlockStart, BlockCount, ChipResponse)

Mx.Read property : ActiveX component optimizes reading speed by using READ or READ4 chip command depending on chip possibilities.

☛ **C Library :** ***Clib_w_ReadBlock*** (BlockStart, BlockCount, Protocol, ChipResponse)

Clib_w_ReadBlockBy4(BlockStart, BlockCount, Protocol, ChipResponse)

☛ **Low level :** **TRANSMIT command** + **0Ch chip command** (single read)
+ **06h chip command** (read4)

All communication with a chip is done thanks to this command, including INSIDE's chips. You will find there how to read one block with the 15 693 standard.

Host	80h	C2h	C5h	08h	02h		0Ch Addh			
Coupler							C2h		Chip's answer	90h 00h

You can also use the Read4 chip command :

Host	80h	C2h	C5h	20h	02h		06h Addh			
Coupler							C2h		Chip's answer	90h 00h

Note : To use another protocol, just change the bit in P2 parameter.

14 443 B-2 : Use 80h C2h C4h...

14 443 B-3 : Use 80h C2h C6h...

WRITING CHIP MEMORY

When writing data to a memory block you have to know if you are communicating to a secure or non secure chip. Parameters will be different as you ask the coupler to send or not the signature to authenticate the data you want to write (this is automatically managed by the ActiveX component).

☛ **ActiveX method :** *Mx.WriteBlock* (BlockStart, BlockCount, BlocksValue)

☛ **C Library :** *Clib_w_WriteBlock* (BlockStart, BlockCount, Protocol, Auth, BlocksValue)

☛ **Low level :** **TRANSMIT command + 87h chip command**

This command enables you to write one block. The following example are for a 15 693 communication.

Non secure chips

Host	80h	C2h	E5h	08h	0Ah		87h Addh &Data	
Coupler						C2h		Written data 90h 00h

Secure chips

Host	80h	C2h	6Dh	08h	0Ah		87h Addh &Data	
Coupler						C2h		Written data 90h 00h

Note : To use another protocol, just change the appropriate bit in P2 parameter :

Non secured chip : 14 443 B-2 : Use 80h C2h E4h...
 14 443 B-3 : Use 80h C2h E6h...

Secured Chip : 14 443 B-2 : Use 80h C2h 6Ch...
 14 443 B-3 : Use 80h C2h 6Eh...

TIPS : to halt the chip as soon as you get its serial number, use P1 parameter in the SELECT_CARD command

HALTING A CHIP

The following command halts the current selected chip :

- ☛ **ActiveX method** : *Mx.Halt*
- ☛ **C Library** : *Clib_w_Halt* (protocol)
- ☛ **Low level** : **TRANSMIT command + 00h chip command**

Host	80h	C2h	31h	00h	01h		00h		
Coupler						C2h		90h	00h

Note : To use another protocol, just change the appropriate bit in P2 parameter :

- 14 443 B-2 : Use 80h C2h 30h...
- 14 443 B-3 : Use 80h C2h 32h...

TIPS : The low level command SELECT_CARD includes an option that halts the chip as soon as it is selected. This enables to earn time by avoiding to send the HALT command. Just use the following P1 parameters : P1 = 02h.

HOW TO WORK WITH SEVERAL CHIPS IN THE FIELD

Here is the basic algorithm to get serial numbers of all chips in a given RF field :

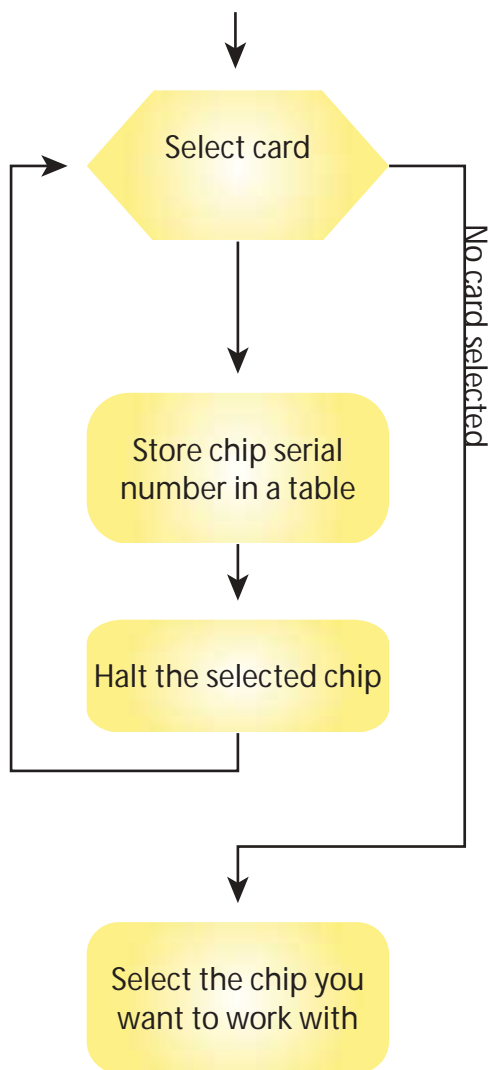

Chips inventory

Make a loop with the SELECT_CARD COMMAND with HALT option enable (P1 = 02h).

Chip selection with its serial number

Use the following command to select a given chip thanks to its serial number. The chip will answer you its serial number.

- ☛ ActiveX method : ***Mx.ReSelect*** (ChipSN)
- ☛ C Library : ***Clib_w_ReSelect*** (ChipSN)
- ☛ Low level : **TRANSMIT command + 81h chip command**

Host	80h	C2h	C5h	08h	09h		81h & Serial Number	
Coupler						C2h	Serial number	90h 00h

Replace C5h by C4h (C6) to use 14 443 type B-2 (type B-3) protocol.

MANAGING INSIDE'S CHIPS PROTOCOLS

Low level command and C library

Protocols are always indicated in the command parameters (P2 for SELECT_CARD, P1 for TRANSMIT). You will find the appropriate value in this **User's Guide**, and in the description of each command in the «**Reference manual**».

ActiveX component

There are 2 command types :

- Card selection
- Select page, read, write...

Card selection

When selecting a card, you set the protocol to use in P2 parameter of the **Mx.SelectCard** method. Coupler is able to test several protocols, and return the protocol use for card detection.

Other operation (Read, Write, SelectPage etc...)

For any other operation, use the ActiveX propertie **Mx.MxProtocolIndex** to set the protocol you want to use.

This property is automatically set after a SelectCard command thanks to the value returned by the coupler indicating the protocol use for card selection.

If you want to change communication protocol when using a dual protocol chip (PICOPASS - 15 693 & 14 443 type B), just change this property value to the desired one, and all activeX command for INSIDE chip will use this protocol.

MANAGING THE SECURITY

INSIDE chips security is based on secret keys that protect and authenticate the chip content.

On one hand, keys are stored in the chip. On the other hand, coupler includes a security module in which are stored the application keys.

Security is based on checking that keys are the same in the chip and in the coupler.

First paragraph explains on what is based our security and what it is for :

- Authentication
- Signature
- Diversified keys

The following paragraphs explain how to :

- load the key into the coupler / SAM
- select and / or authenticate a chip with a given key

INSIDE CHIPS SECURITY

Security consists in protecting memory access and e-purse use by secret keys. User will be able to modify card content only if the coupler contains same secret keys as PICO chip.

Security is checked several times :

- **Authentication** : Just after having selected the chip user has to perform an authentication before being able to access any memory data.
- **Signature** : for any memory modification the chip user has to send a signature calculated as a function of sent data, secret keys and chip serial number. Thus it is impossible to modify the chip content without knowing the application keys.

In each security calculation, a diversified key is being used, based on the chip serial number and the application key.

All security calculations are automatically manage by INSIDE's couplers.

Key diversification

To ensure a reliable security, every security operation (authentication, signature calculation) is based on diversified key value.

The diversified key is an 8 bytes result of calculation including chip serial number and key value.

Thus, 2 chips using same keys contain different diversified key values. This ensures that it is not possible to repeat some sequence registered on one card on another card.

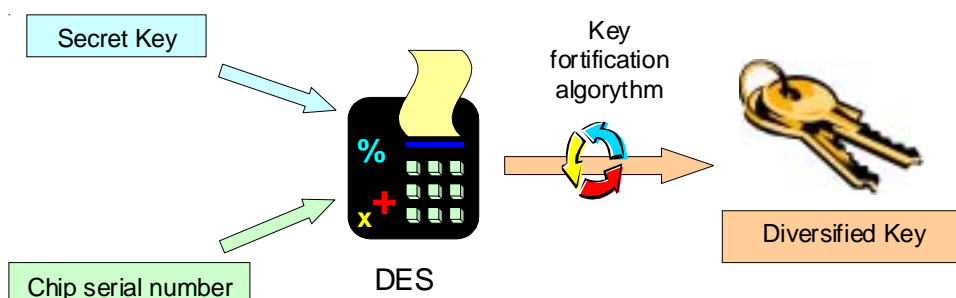

INSIDE
security protects
memory from **REA-**
DING and/or **WRITING**.

Security
control e-purse
(stored value) manage-
ment

Security is
based on :
- key diversification
- authentication
-signature

Key diversifi-
cation implies that
each security
calculation is different
for each card

Authentication protects the memory from reading and writing

Authentication

Authentication algorithm performs a *mutual* authentication. The principle is as follows : Data are exchanged then both device perform secret calculations on them to obtain 2 results on 4 bytes. Authentication is done if they get the same results. The chip first checks coupler's response then reader verifies chip's results.

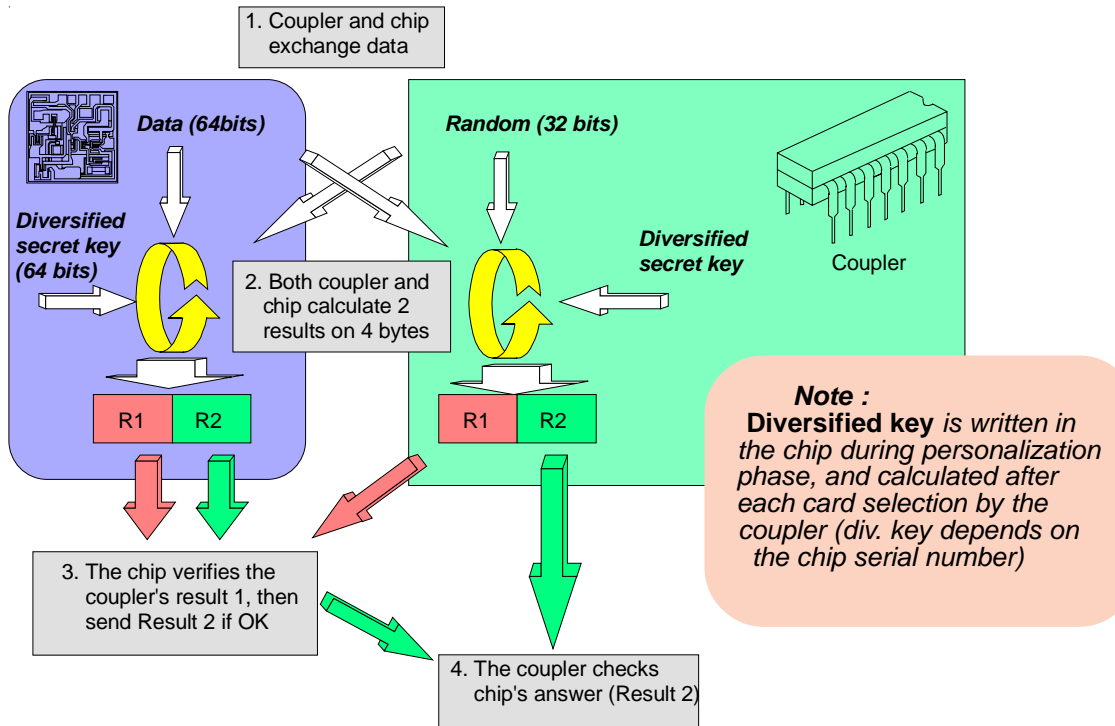

Signature when writing increases memory content security

Signature

Each time you want to send data to the chip, a 32 bits signature is automatically calculated and added. Signature calculation takes into account the diversified key value (result of operation between key value and chip serial number) and the data. Chip will check the signature to allow data writing. This ensures very good security on the chip content.

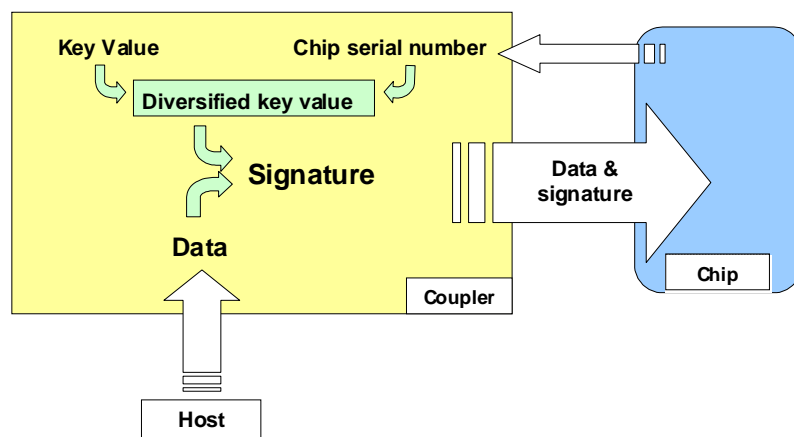

Signature calculation principle

First step in security is to load the secret keys into the coupler

KEY LOADING

To perform this complex operation, use the function supplied with the libraries (C Libraries, ActiveX component). You will find encryption algorithm in annex. C source code is provided in the C library, and ActiveX component manage automatically all security calculation.

You need to give the following parameter :

- * Key number
- * Exchange Key
- * New Key value

☞ ActiveX method : *Mx.KeyLoading*

Use **Mx.KeyLoading** (**KeyNum**, **LoadingType**, **ExchangeKey**,**NewValue**) method to load the key in the coupler at the appropriate place.

Keynum may have to following value :

- **mpkP_iKd** (i=0 to 7)
- **mpkP_iKc** (i=0 to 7)

Example : to load the default keys as keys 6 using the default exchange key ...

```
Mx.KeyLoading (mpkP6Kd, mklmXORKe, «$5C$BC$F1$DA$45$D5$FB$5F»,
«$F0$E1$D2$C3$B4$A5$96$87»)
Mx.KeyLoading (mpkP6Kc, mklmXORKe, «$5C$BC$F1$DA$45$D5$FB$5F»,
«$76$65$54$43$32$21$10$00»)
```

☞ C Library : *Clib_w_KeyLoading*

Clib_w_KeyLoading (**KeyNum**, **LoadingType**, **ExchangeKey**,**NewValue**)

☞ Low level : *LOAD_KEY_FILE*

Calculate the Encrypted key thanks to the C library algorithm (see annexe A) and use the **LOAD_KEY_FILE** command...

Host	80h	D8h	00h	P2	OCh		Encrypted key	
Coupler						D8h		90h 00h

P2 : Key number

00h - Exchange Key Ke: used for key loading operation.

01h - Debit Key Kd0

02h - Credit Key Kc0

03h - Debit Key Kd1

04h - Credit Key Kc1

.....

0Fh - Debit Key Kd7

10h - Credit key Kc7

Second step:
tell the coupler which
key has to be used

HOW TO SET A KEY AS THE ACTIVE ONE

A - Before SelectCard command

☞ **ActiveX component :** *Mx.CurrentKey*

Possible values are :

- mpkP_iKd (i=0 to 7)
- mpkP_iKc(i=0 to 7)

☞ **C Library :** *Clib_w_SelectCurrentKey*
Clib_w_SelectCurrentKey (KeyNum)

☞ **Low level :** **SELECT_CURRENT_KEY** command

Host	80h	52h	00h	P2h	08h		8 * 00h	
Coupler						52h		90h 00h

P2 : Key number

- 00h - Exchange Key Ke: used for key loading operation.
- 01h - Debit Key Kd0
- 02h - Credit Key Kc0
- 03h - Debit Key Kd1
- 04h - Credit Key Kc1
-
- 0Fh - Debit Key Kd7
- 10h - Credit key Kc7

B - Before SelectPage and Authentify command

At this stage you need to precise both the key number and the chip serial number (as you may be working with several chips).

Actually this operation is performed automatically by the selectCard command as it knows the key number thanks to the CurrentKey property, and the Serial Number is given by the chip during the selection phase.

When using a standard coupler, the *DiversifyKey* command returns a useless data (random number). The returned data are used only with a personalisation coupler. More information are given in the personalisation kit.

☞ **ActiveX component :** *Mx.DiversifyKey*

Mx.DiversifyKey (KeyNum, Chip Serial Number, Databack)

☞ **C Library :** *Clib_w_DiversifyKey*

Clib_w_DiversifyKey (KeyNum, Chip Serial Number, Databack)

☞ **Low level :** **DIVERSIFY_KEY** command

Host	80h	52h	00h	P2h	08h		Serial Number	
Coupler						52h		90h 00h

P2 : Key number

- 00h - Exchange Key Ke: used for key loading operation.
- 01h - Debit Key Kd0
- 02h - Credit Key Kc0
- 03h - Debit Key Kd1
- 04h - Credit Key Kc1
-
- 0Fh - Debit Key Kd7
- 10h - Credit key Kc7

Last step :
Authentication is performed during chip selection and/or page selection

Tips : Key diversification is automatically done by the select card command

Tips : Key diversification has to be done only once. You don't need to use the Diversify command as soon as you work with the same chip and the same key

HOW TO AUTHENTICATE A CHIP

Authentication may be done while selecting the card (or the page). It can also be done later, for example when you want to work with both Credit key and Debit key authentication.

☞ **ActiveX component : *Mx.SelectCard***

SelectCard (30h ...) authenticates selected chip with Kd
SelectCard (10h ...) authenticates selected chip with Kc

☞ **C Library : *Clib_w_SelectCard***

Clib_w_SelectCard (SelectMode , ChipType, TypeSN)

SelectMode = 30h : Authenticate with the chip debit key

SelectMode = 10h : Authenticate with the chip credit key

☞ **Low level : *SELECT_CARD***

80h A4h 10h P2 09h => Authenticate with Kc

80h A4h 30h P2 09h => Authenticate with Kd

HOW TO AUTHENTICATE A PAGE

Authentication follows the same principle as for the SelectCard authentication.

If you want to use a different key than the one used during the card selection, or if selection has been done without you have to use the DiversifyKey command to set a key as the active key if you want to change the active key.

☞ **ActiveX component :**

Mx.DiversifyKey (KeyNum, Chip Serial Number, Databack)

SelectAuthPage (Key, Page, BlockConfig)

☞ **C Library :**

Clib_w_Mx.DiversifyKey (KeyNum, Chip Serial Number, Databack)

Clib_w_SelectAuthPage (Key, Page, BlockConfig)

☞ **Low level : *DIVERSIFY_KEY & SELECT_PAGE***

DIVERSIFY_KEY

Host	80h	52h	00h	P2h	08h		Serial Number	
Coupler						52h		90h 00h

P2 : key number

SELECT_PAGE

Host	80h	A6h	P1	P2	08h			
Coupler						A6h	Chip 's configuration block	90h 00h

P1 : contactless configuration

P2 : key and page number

PROTECTING THE KEYS

Thus all the security depends on making sure that these keys are kept secret. To ensure a good security, key loading has to be done in a secure environment.

The key loading procedure ensures that :

- 1 - nobody decrypts the key loaded in the coupler by listening to the HOST-COUPLER communication
- 2 - nobody records and uses the communication between HOST and COUPLER to load keys in another coupler

To protect the communication, all data exchange is ciphered thanks to an exchange key known only by the coupler. Therefore, nobody will be able decipher serial communication and find the application key value

Protect key storage (coupler, security module) so that nobody can use your keys.

Use our coupler security protection features or store coupler or SAM keys in a secured place.

To ensure a very good security to your application, contact us so we help you to give to your system the security it deserves.

MANAGING STANDARD CHIPS PROTOCOLS

This chapter explains how to communicate with any chips that follow the 13.56MHz standards : 15 693, 14 443 Type A and B. More over, you will find there how to communicate with the FeliCa chip (SONY).

Note : user's will find there the commands to use to send byte to the chip, and to get the chip answer, but we will not mention the way to manage these chips. User has to refer to the chip datasheet or ISO standards to find more information about these chips.

TIME OUT ADJUSTMENT

When communicating with a chip, and particularly a microprocessor, user may need to increase the time out value.

The TimeOut configuration enables the user to change the value of the TRANSMIT command to be sure that no ISO command will fail because a too short timeout.

Users can change 4 timeout values corresponding to the 4 Timeout "slots" that one can use in TRANSMIT command:

- Timeout 0 (command timeout option = b00) : Address h68
- Timeout 1 (command timeout option = b01) : Address h69
- Timeout 2 (command timeout option = b10) : Address h6A
- Timeout 3 (command timeout option = b11) : Address h6B

Where "b" prefix is for binary value, "h" is for hexadecimal

To put a specific value for one of these TimeOut "slots", developer can use the following formulas:

ISO 14443 (A-B) : TimeOut = X . 380µs + 200µs

ISO 15693 : TimeOut = (X << 2) . 380µs + 200µs

Where X is the value of the byte and << is the operation that execute a binary right shift of the byte value.

15 693-3 PROTOCOL

This example shows how to configure the protocol, then how to send the INVENTORY command.

Public sub Sample_15693()

' Configure USER protocol as 15693

Mx.MxUserProtocol = mupISO_15693_3_10pc

'Low level command : use the SetStatus function

'Mx.SetStatus &H3, &H5E, &H21

'Mx.SetStatus &H3, &H5F, &H31

' Send Inventory command "1 slot" to retrieve chip serial number

Command = "\$36\$01\$00\$00"

CommandSize = &H04

AnswerSize = &H0A

UserProtocol = &HF3

Mx.Transmit UserProtocol, AnswerSize, CommandSize, Command, ChipAnswer

' Send slot marker for anticollision management

Mx.Transmit &H73, &H0A, &H00, « », ChipAnswer

End Sub

ISO 14 443 TYPE A

Public sub Sample_14443_A()

' **Configure USER protocol as 14443-A level 3**

Mx.MxUserProtocol = mupISO_14443A_3

' **Low level : use the set status command**

'Mx.SetStatus &H03, &H5E, &H32

'Mx.SetStatus &H03, &H5E, &H12

'Mx.SetStatus &H03, &H64, &H63

'Mx.SetStatus &H03, &H65, &H63

' **Use the SelectCard command to manage anticollision**

Mx.SelectCard &H00, &H08, Type_SN

' **Send the RATS command :**

Buffer length = 32

Name the card as card 0

Command = "\$50\$00"

CommandSize = &H02

AnswerSize = &H06

UserProtocol = &HF3

Mx.Transmit UserProtocol, AnswerSize, CommandSize, Command, ChipAnswer

End Sub

ISO 14 443 TYPE B

Public sub Sample_14443_B()

' **Card selection with the select Card command : manage the anticollision**

Mx.SelectCard &H00, &H04, Type_SN

' **Send REQB command**

Command = "\$05\$00\$00"

CommandSize = &H03

AnswerSize = &H0C

UserProtocol = &HF2

Mx.Transmit UserProtocol, AnswerSize, CommandSize, Command, ChipAnswer

End Sub

FELICA (NEW VERSION)

' **Low level : use the set status command to configure the protocol**

Mx.SetStatus &H03, &H5E, &H79

Mx.SetStatus &H03, &H5E, &H02

Mx.SetStatus &H03, &H64, &H00

Mx.SetStatus &H03, &H65, &H00

' **Send a command to the chip and retrieve the answer**

Command = "\$06\$00\$FF\$FF\$00\$01"

CommandSize = &H06

AnswerSize = &H12

UserProtocol = &HF7

Mx.Transmit UserProtocol, AnswerSize, CommandSize, Command, ChipAnswer

MANAGING THE RF FIELD

Possible operations you can perform on the RF field are the following :

- * Cut RF emission, mainly when couplers are powered on battery
- * Start RF emission
- * «Reset» RF field (i.e. cut it for 20 ms in order to reset any halted chip in the field)

HOW TO RESET THE RF FIELD ?

This command will cut the RF field for 20 ms in order to reset all chips that are in the field.

☞ ActiveX method : *Mx.ResetField*

☞ C Library : *Clib_w_ResetField ()*

☞ Low level : **SET_STATUS** command

<i>Host</i>	80h	F4h	40h	00h	01h		00h		
<i>Coupler</i>						F4h		90h	00h

HOW TO ASLEEP THE COUPLER

Just use the disable command which will cut the RF field so that no energy is wasted.

☞ ActiveX method : *Mx.Disable*

☞ C Library : *Clib_w_Disable ()*

☞ Low level : **DISABLE** command

<i>Host</i>	80h	ADh	BCh	DAh	00h		
<i>Coupler</i>						90h	00h

HOW TO WAKE UP THE COUPLER

☞ ActiveX method : *Mx.Enable*

☞ C Library : *Clib_w_Enable ()*

☞ Low level : **ENABLE** command

<i>Host</i>	80h	A Eh	DAh	BCh	00h		
<i>Coupler</i>						90h	00h

Important note

Low level command : You have to send this command in a window of 16 ms so that the coupler catches it. To be sure that this command is detected, send it twice, with no more than 10 ms between the 2 commands sending. This is automatically managed by the ActiveX method.

APPENDICES

APPENDIX A HOW TO LOAD A KEY IN A COUPLER

This procedure consists in several operations on the key. The final result will be sent to the coupler using the **Loag_Key_File** function.

EXCHANGE KEY

To ensure the security, an **exchange key** will protect all key loading operations. This key is in the coupler memory and has 2 functions :

- only host knowing this key will be able to modify the Debit and Credit keys.
- New key value are encrypted with this exchange key so it is not possible to read the new value on the serial line.

You have to know this exchange key to modify the value of any other key. For any modification, the Exchange key is managed exactly as the Debit key and the Credit key : you have to use the Key Loading Procedure described in the next paragraphs.

GENERAL KEY LOADING PROCEDURE

Before the key loading starts with the LOAD_KEY_FILE command, the host must generate a session key. This key is generated by the encryption of the current Exchange Key (Ke) with an 8-byte random number.

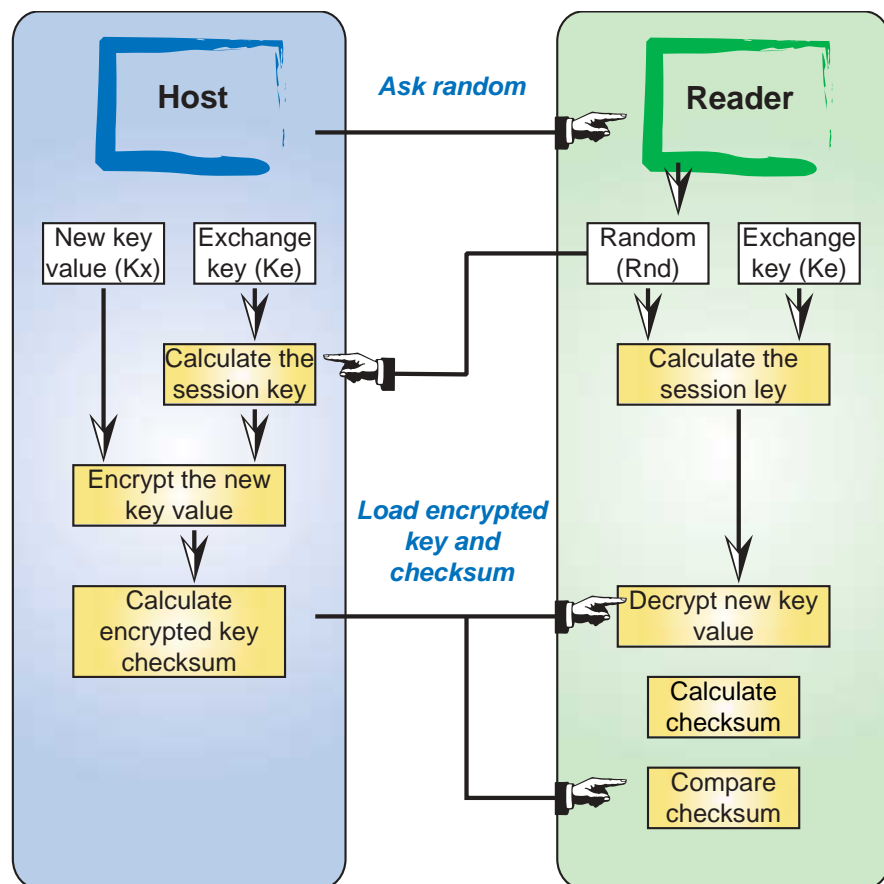

TERMINOLOGY AND NOTATION

Adding **p** after the key name means that the key is permuted.
 Adding **chk** means that the 8th byte replaced by the Checksum byte value.
 A **C** before the key name means that the key has been encrypted.

Abbreviation	Meaning
K_{ex}	Exchange Key.
$K_{ex,p}$	Permuted Exchange Key.
$K_{ex,p,chk}$	Key with the 8 th byte replaced by the Checksum byte value.
Rnd	Random number.
K_x	Master key. (K_x equals to K_d or K_c)
$K_{x,p}$	Permuted master key. ($K_{x,p}$ equals to $K_{d,p}$ or $K_{c,p}$)
CKxp	Encrypted permuted master key. (CK _{x,p} equals to CK _{d,p} or CK _{c,p})
SK	Session key.
CHK	4-byte checksum.

KEY LOADING STEP BY STEP

We assume that the default keys are used.

STEP DESCRIPTION	Example
Step 1 : Get a random number from the coupler	
<ul style="list-style-type: none"> Send the Ask_Random command 	<p>Send 80h 84h 00h 00h 08h. The coupler answer a random number. For this example, we assume that Rnd = 00 00 00 00 00 00 00 00.</p>
Step 2 : Calculate the Session Key	
<p>The session key is define by the following formula :</p> $SK = K_{exp_chk} \oplus Rnd \quad (\oplus : \text{bit to bit x-or operation})$ <p>K_{exp_chk} means that we have to permute K_{ex} then to replace the 8th byte by the checksum byte</p> <ul style="list-style-type: none"> Permute the exchange key to get $K_{ex,p}$ replace the 8th byte by the checksum byte to get $K_{ex,p,chk}$ Calculate the session key 	<p>$K_{ex,p} = 6E\ FD\ 46\ EF\ CB\ B3\ C8\ 0B$</p> <p>$K_{ex,p,chk} = 6E\ FD\ 46\ EF\ CB\ B3\ C8\ 75$</p> <p>SK = 6E FD 46 EF CB B3 C8 75</p>
Step 3 : Calculate the Encrypted master key	
<p>This calculation include the exchange key through the session key (SK). This insure the protection of the new key value.</p> $CK_{xp} = SK \oplus K_{xp} \quad (\oplus : \text{bit to bit x-or operation})$ <ul style="list-style-type: none"> Permute the new key value K_x to get $K_{x,p}$ Make a bit to bit X-OR operation with the session key SK 	<p>$CK_{d,p} = 91\ F2\ 75\ BA\ CB\ 43\ 04\ 20$</p>
Step 4 : Send the Load_Key_File command	
<ul style="list-style-type: none"> Calculate the CheckSum Send the command to the coupler. <p>Load_Key_File (CKxp + CheckSum)</p>	<p>Checksum = 73 27 FF 01</p> <p>Send 80 D8 00 01 0C & 91 F2 75 BA CB 43 04 20 & 73 27 FF 01</p>

ALGORITHMS

KEY PERMUTATION

Proceed as described below to permute a key.

Example: Permute the key K_{ex} .

$K_{ex} =$	0x5C	0xBC	0xF1	0xDA	0x45	0xD5	0xFB	0x5F
(0x5F) \oplus	0	1	0	1	1	1	1	1
(0xFB) \oplus	1	1	1	1	1	0	1	1
(0xD5) \oplus	1	1	0	1	0	1	0	1
(0x45) \oplus	0	1	0	0	0	1	0	1
(0xDA) \oplus	1	1	0	1	1	0	1	0
(0xF1) \oplus	1	1	1	1	0	0	0	1
(0xBC) \oplus	1	0	1	1	1	1	0	0
(0x5C) \oplus	0	1	0	1	1	1	0	0
	↓	↓	↓	↓	↓	↓	↓	↓
	0x6E	0xFD	0x46	0xEF	0xCB	0xB3	0xC8	(0xF4)

Replace the last byte by : $\overline{0xF4} = 0B$

$K_{xp} = \quad 0x6E \quad 0xFD \quad 0x46 \quad 0xEF \quad 0xCB \quad 0xB3 \quad 0xC8 \quad 0x0B$

CHECKSUM BYTE CALCULATION

Proceed as described below to calculate a key checksum byte.

Note: the \oplus symbol means a bit to bit x-or operation.

Example:

$K = \quad 0x5C \quad 0xBC \quad 0xF1 \quad 0xDA \quad 0x45 \quad 0xD5 \quad 0xFB \quad 0x5F$

$K_p = \quad 0x6E \quad 0xFD \quad 0x46 \quad 0xEF \quad 0xCB \quad 0xB3 \quad 0xC8 \quad 0x0B$

Checksum = $0x6E \oplus 0xFD \oplus 0x46 \oplus 0xEF \oplus 0xCB \oplus 0xB3 \oplus 0xC8 = 0x8A$

Checksum = $0x8A = 0x75$

and then,

$\overline{K_{xp_chk}} = \quad 0x6E \quad 0xFD \quad 0x46 \quad 0xEF \quad 0xCB \quad 0xB3 \quad 0xC8 \quad 0x75$

LOAD KEY CHECKSUM CALCULATION

- \oplus Complete the 5 command bytes with 3 bytes 00 so to get 8 bytes
- \oplus Calculate $RES = (\text{Command bytes}) \oplus K_{xp}$.
- \oplus Calculate the checksum $CHK = \text{Most Significant 4-Bytes}(RES) \oplus \text{Least Significant 4-Bytes}(RES)$.

Example:

The checksum when sending the default Debit Key K_d is :

Command = 80 D8 00 01 0C 00 00 00
 K_d p = FF 0F 33 55 00 F0 CC 55
RES = 7F D7 33 54 0C F0 CC 55
CHK = 73 27 FF 01

	MSB(RES)	7F	D7	33	54
⊕	LSB(RES)	0C	F0	CC	55
<hr/>					
	CHK =	73	27	FF	01

APPENDIX B ERROR CODE

When an error occurs, coupler response is only status words SW1 SW2. No data is returned.

The following table sums up the various values.

SW1	SW2	Error description
90h	00h	Command successful
Common status errors		
67h	00h	Data length, P3 incorrect
6Bh	00h	Parameters P1, P2 incorrect
6Eh	00h	Class not recognized
6Dh	00h	Instruction not recognised, parity error
Security errors		
69h	82h	Card not identified (CRC or authentication problem)
98h	35h	Command flow incorrect
Execution error		
6Ah	82h	Card not found
62h	00h	EEPROM erro