

User Guide



7 Megapixel Digital Camera

NS-DSC7B-09, NS-DSC7P-09, and NS-DSC7S-09

Insignia NS-DSC7B-09, NS-DSC7P-09, or NS-DSC7S-09 7 Megapixel Digital Camera

Contents

Welcome	3
Safety information	3
Features	3
Setting up your camera	5
Using your camera	8
Basic picture taking	11
Viewing photos and video	18
Editing your photos	19
Making connections	22
Specifications	23
Appendix	24
Available functions	25
Legal notices	28
One-Year Limited Warranty	29

Welcome

Congratulations on your purchase of a high-quality Insignia product. Your NS-DSC7B-09, NS-DSC7P-09, or NS-DSC7S-09 represents the state of the art in digital camera design and is designed for reliable and trouble-free performance.

Safety information

	The lightning flash with arrowhead symbol within an equilateral triangle is intended to alert you to the presence of uninsulated dangerous voltage within your shelf system's enclosure that may be of sufficient magnitude to constitute a risk of electric shock.
---	---

	The exclamation point within an equilateral triangle is intended to alert you to the presence of important operating and maintenance (servicing) instructions in the literature accompanying your shelf system.
---	---

Before using the camera, read and understand the safety precautions described below. Always make that you operate the camera correctly.

- Do not aim the camera directly into the sun or other intense light sources that could damage your eyesight.
- Do not try to open the case of the camera or attempt to modify this camera in any way. High-voltage internal components create the risk of electric shock when exposed. Maintenance and repairs should be carried out only by authorized service providers. Moisture creates the danger of electric shock.

- Do not fire the flash too close to the eyes of animals or people, especially for young children. Eye damage may result. Remain at least three feet (one meter) away from infants when using flash.
- Keep the camera away from water and other liquids. Do not use the camera with wet hands. Never use the camera in the rain or snow.
- Keep the camera and its accessories out of the reach of children and animals to prevent accidents or damage to the camera.
- If you notice smoke or a strange odor coming from the camera, turn the power off immediately. Take the camera to the nearest authorized service center for repair. Never attempt to repair the camera yourself.
- Use only the recommended power accessories. Use of power sources not expressly recommended for this equipment may lead to overheating, distortion of the equipment, fire, electrical shock, or other hazards.
- Do not swing the camera around by the strap.

Features

Included

- 7 megapixel digital camera
- 2 AA Alkaline batteries
- Wrist strap
- USB cable
- AV cable
- User Guide CD
- *Quick Start Guide*

Front



#	Component	Description
1	Flash	Lets you take photos in low-light conditions.
2	Self-timer LED	Flashes to indicate that the self-timer is activated.
3	Microphone	Lets you record audio clips and memos.
4	Lens	Focuses the photo.

Back

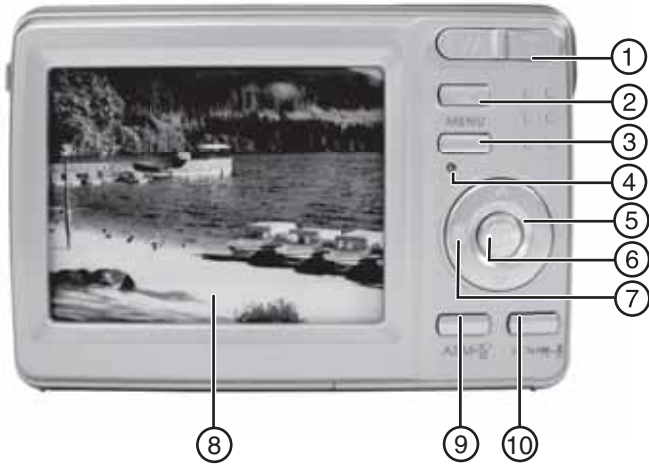

Top, bottom and side

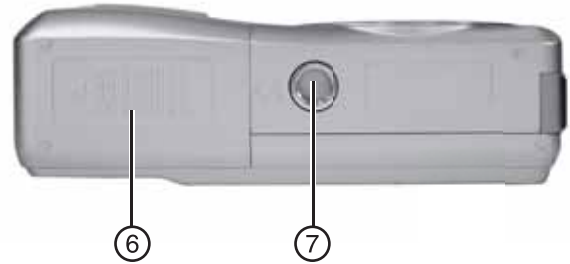

#	Component	Description
1	Zoom button	Press T to zoom in on a subject for telephoto photos, or press W to zoom out for wide-angle photos.
2	Playback button	Press to view the photos you have taken.
3	Menu button	Press to open the camera menu system to let you change camera settings.
4	Power indicator LED	Lights green when the camera is on.
5	Flash button	Press to cycle through the available flash options.
6	SET/DISP button	In REC or PLAYBACK mode, press to change the LCD monitor view. In menu mode, press to confirm your settings.
7	Macro button	Press to enable shooting close-up photos.
8	LCD	Use to compose your photos and to view the various menus.
9	Mode button	Press to open the mode palette, from which you can select a scene mode.
10	ASM button	Press to set the ASM (Aperture, Shutter, Manual Exposure) mode.

#	Button	Description
1	Speaker	Lets you hear audio clips and memos recorded on the camera.
2	Power button	Press to turn on your camera.
3	Shutter button	Press to take a photo.
4	Strap ring	Attach the carrying strap (included) to this ring.
5	USB/AV jack	Lets you connect the camera to a TV or computer.
6	Battery cover	Open to install batteries and an optional memory card.
7	Tripod socket	Use to mount the camera to a tripod.

Setting up your camera

Installing the batteries

To install the batteries:

- 1 Open the battery cover by sliding it in the direction indicated in the illustration.

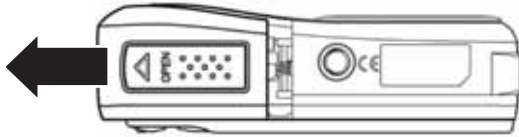

- 2 Insert two AA batteries into the battery compartment. Make sure that you match the + and - symbols on the batteries with the + and - symbols in the battery compartment.

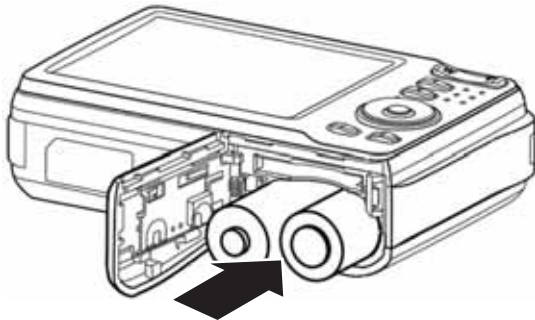

- 3 Close the battery cover.

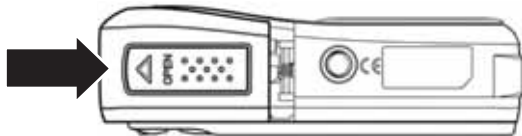

- 4 If you are replacing the batteries, go to the *Setup* menu and make sure that the battery type is correct. (see "Setup menu" on page 11)

Warning

There is a risk of explosion if the batteries are replaced with the incorrect type.

Notes

- A low battery indicator  appears on the LCD when the batteries are nearly exhausted. Batteries should be replaced promptly when this indicator appears.
- Do not mix batteries of different types.
- Do not mix old and new batteries.
- Remove batteries when the charge is depleted.
- Battery chemicals can cause a rash. If the batteries leak, clean the battery compartment with a cloth. If chemicals touch your skin, wash immediately.
- If the camera is not going to be used for an extended period of time, remove the batteries.
- The camera body may feel warm to the touch after extended use. This is normal.

Understanding camera memory

This camera is equipped with 16 MB of internal memory. If a memory card is not inserted in the camera, all images and movie clips recorded by the camera will be stored in the internal memory. If a memory card is inserted, images and movie clips are stored on the memory card.

DCF protocol

The DCF protocol defines the format for image file data as well as the directory structure for the memory card. Images that are taken by a DCF camera can be viewed on DCF-compatible cameras from other manufacturers.

Installing the memory card

You can use an SD memory card with this camera. The memory card slot is inside the battery cover, adjacent to the battery compartment.

Caution

- The memory card may be damaged if it is removed while the camera is on.
- Do not touch the contacts on the back of the memory card.

To install the memory card:

- 1 Turn off the camera.
- 2 Open the battery cover by sliding it in the direction indicated in the illustration.

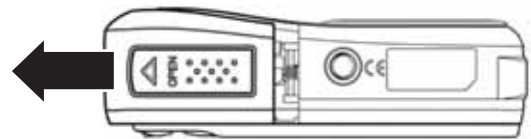

- 3 Insert the memory card with the label facing up and the arrow pointing in.

Tip

To remove the memory card, push the card in slightly to release it, then pull the card out of the card slot and remove it.

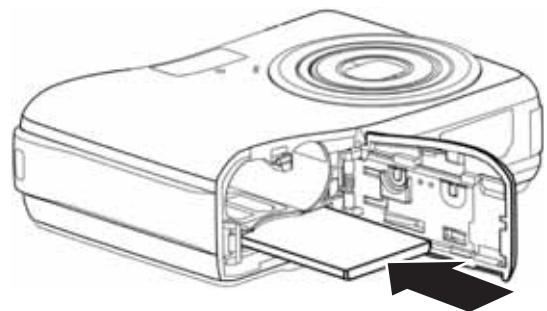

- 4 Close the battery cover.

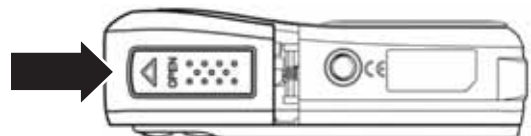

Making initial settings

When using the camera for the first time, make sure that you choose a language and set the date and time before using the camera.

To set the display language:

- 1 Turn the power on.
- 2 Press **PLAY**, then press **MENU**. The initial menu is displayed on the LCD monitor.
- 3 Press **▼**, **▲**, **◀**, or **▶** to select **SETUP**, then press **SET**. The *Setup Menu* opens.



- 4 Press **▼** or **▲** to select **Language**, then press **SET**. The *Language* sub-menu opens.
- 5 Press **▼** or **▲** to select the language you want, then press **◀** or **SET** to apply the setting.
- 6 Press **MENU** to exit the menu.

To set the date and time:

- 1 Turn the power on.
- 2 Press **PLAY**, then press **MENU**. The initial menu is displayed on the LCD monitor.
- 3 Press **▼**, **▲**, **◀**, or **▶** to select **SETUP**, then press **SET**. The *Setup Menu* opens.
- 4 Press **▼** or **▲** to select **Date & Time**, then press **SET**. The *Date & Time* menu opens with the year highlighted.



- 5 Press **▼** or **▲** to change the year, then press **◀** or **▶** to move to the next setting.

Tips

- Hold down **▼** or **▲** to change the settings continuously.
- See "Setting the date stamp" on page 18 to add a date stamp to your photos.

- 6 Repeat Step 4 for all settings, then press **SET** or **MENU** to apply the settings.

Note

If the batteries are removed for longer than 48 hours, the date and time must be reset.

Understanding the LCD

Use the LCD to compose images while recording, adjusting settings, or replaying images. The following indicators may appear on the LCD while recording or playing back images.

Record (REC) mode

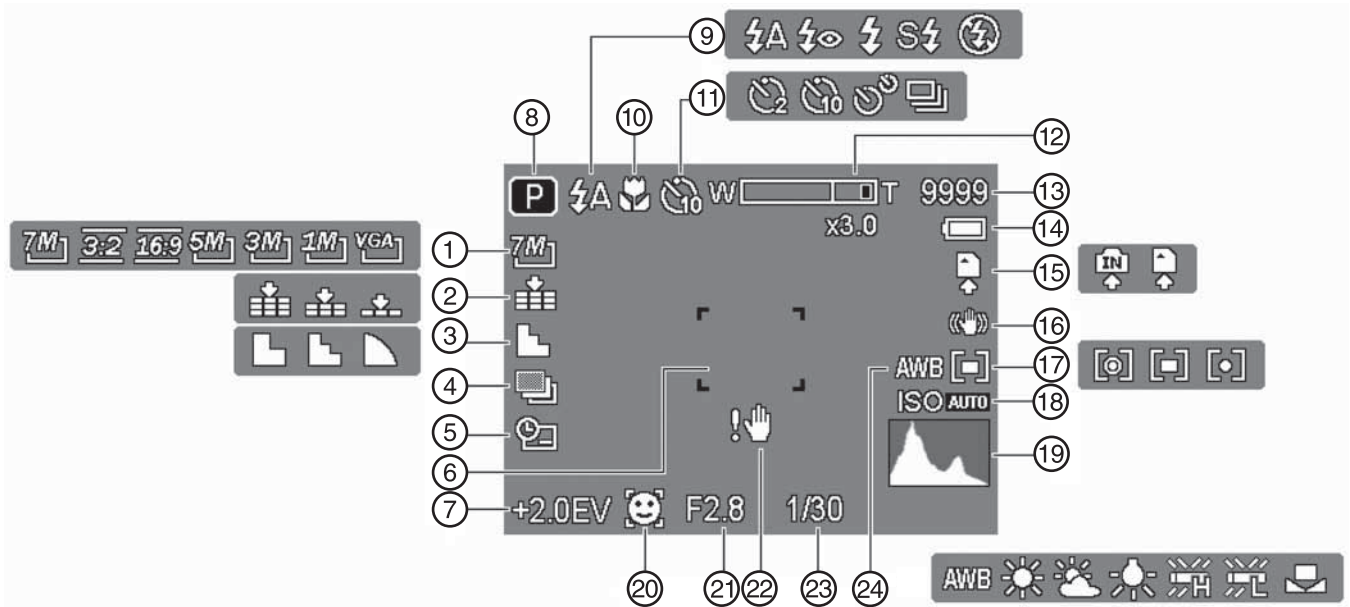

#	Description	For additional information, see...
1	Resolution	"Setting image size and quality" on page 12
2	Quality	"Setting image size and quality" on page 12
3	Sharpness	"Setting the sharpness" on page 17
4	AEB	"Setting the AEB (auto exposure bracketing)" on page 17
5	Date stamp	"Setting the date stamp" on page 18
6	Focus area	"Taking still pictures" on page 11
7	Exposure	"Setting the exposure" on page 17
8	Recording mode	"Changing the mode" on page 9
9	Flash	"Using the flash" on page 13
10	Macro	"Using the macro feature" on page 14
11	Self-timer/Burst	"Using the self-timer and burst" on page 14
12	Zoom indicator	"Using Zoom" on page 13
13	Shots remaining	
14	Battery indicator	"Installing the batteries" on page 5
15	Storage media	"Installing the memory card" on page 5
16	Stabilizer	"Setting the stabilizer" on page 18
17	Metering	"Setting the metering" on page 17
18	ISO	"Setting the ISO sensitivity" on page 17
19	Histogram	
20	Face tracking	"Setting face tracking" on page 18
21	Aperture setting	"Using the aperture priority setting" on page 14
22	Shake warning	"Taking still pictures" on page 11
23	Shutter speed	"Using the shutter priority setting" on page 15
24	White balance	"Setting the white balance" on page 17

PLAYBACK mode

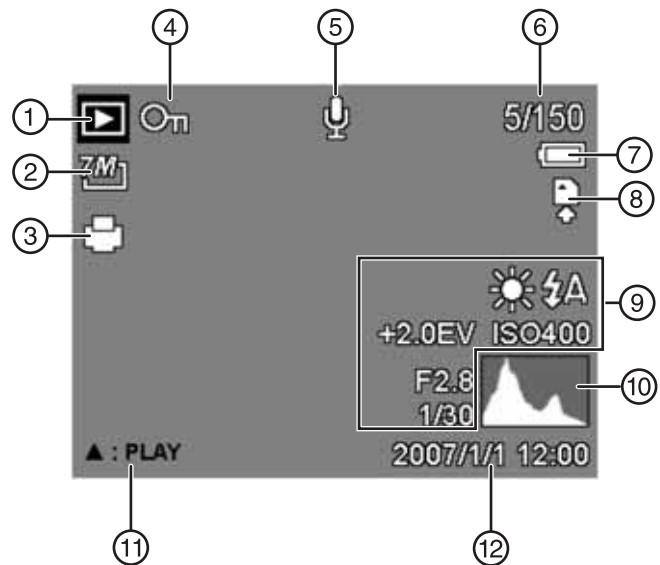

#	Description	For additional information, see...
1	Playback mode	"Changing the mode" on page 9
2	Resolution	"Setting image size and quality" on page 12
3	DPOF	"Setting the Digital Print Order Format (DPOF)" on page 21
4	Protect	"Protecting files" on page 21
5	Voice memo	"Recording a voice memo" on page 16
6	File number/total	
7	Battery indicator	"Installing the batteries" on page 5
8	Storage media	"Installing the memory card" on page 5
9	Recording info	
10	Histogram	

#	Description	For additional information, see...
11	Voice memo control	"Recording a voice memo" on page 16
12	Captured date and time	Shows the date and time that the photo was taken.

To change the LCD monitor configuration:

- Press **SET/DISP** repeatedly to change the configuration.
- REC mode**—

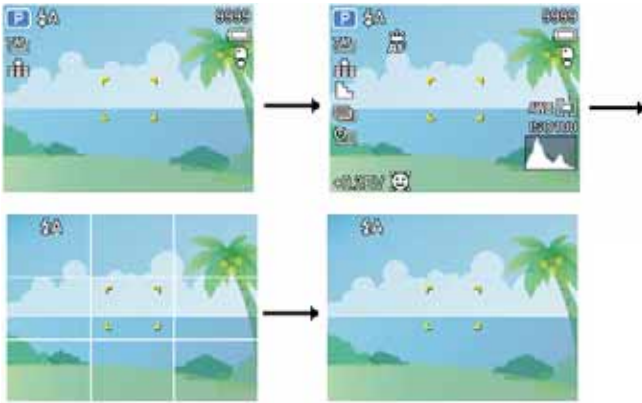

- PLAYBACK mode**—

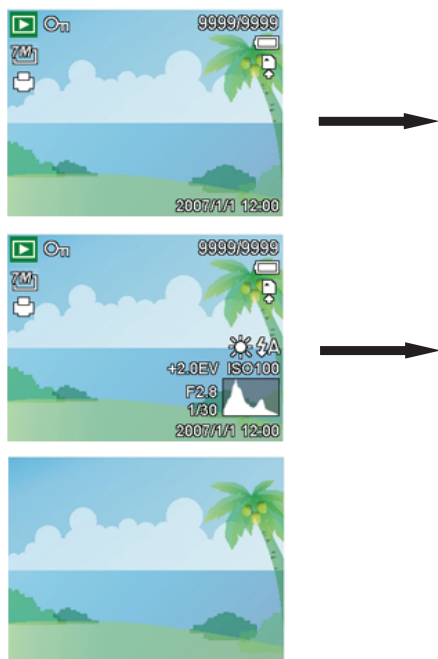

Note

You cannot change the LCD configuration in the following situations:

- The camera is set to manual exposure.
- You are recording or playing movie clips or audio files.
- You are playing a slide show.
- You are viewing thumbnail images.
- You are trimming a still image.

Using your camera

Basic operation

To turn your camera on and off:

- Press **Power** ① to turn your camera on in REC mode. The power turns on, the lens extends, and the power indicator LED turns green.

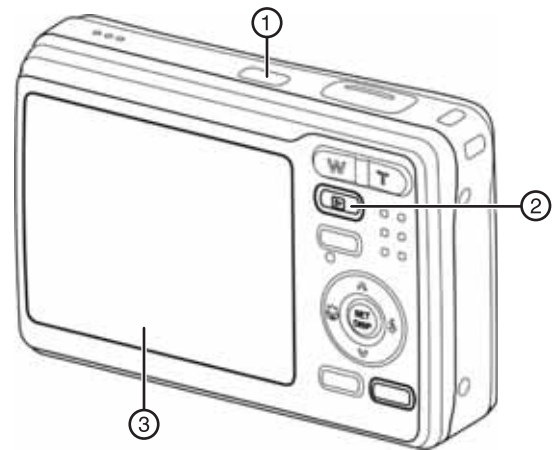

- OR -

Press **Playback** ② to turn your camera on in PLAYBACK mode. The power turns on and an image displays on the LCD ③.

- Press **Power** again to turn your camera off. The power turns off, the lens retracts, and the power indicator LED turns off.

Tips

To turn your camera on without the startup and operating sound, press and hold **Power** or **Playback** for 1.5 seconds.

Note

To save battery power, the LCD turns off automatically after one minute of inactivity (no button pressed). To turn the LCD back on, press any button other than **Power**. You can change the power save settings in the Setup menu (see "Using the Setup menu" on page 10).

After power save has been active for one minute, your camera turns off completely. Press **Power** or **Playback** to turn your camera back on.

Power save does not turn the camera off in the following situations:

- You are recording or playing movie clips or audio files.
- You are playing a slide show.
- You are connecting the camera to a computer or printer with the USB cable.

Changing the mode

You can record images and voices in **record** mode and you can use the **playback** mode to replay, delete, or edit images on the LCD monitor.



To switch between modes:

- In REC mode, press **Playback** ① to switch to **playback** mode.
- In **playback** mode, press **Playback** ① or **Mode** ② to switch to **record** mode.

Selecting the REC scene mode

To select the record scene mode:

- 1 Turn on your camera and set it to REC mode.
- 2 Press **Mode** ② to display the **scene** mode palette. The **scene** mode palette opens.



- 3 Press **▼**, **▲**, **◀**, or **▶** to select the scene mode you want, then press **SET** to confirm the setting.

Icon	Scene mode	Description
	Portrait	Blurs the background and focuses on the subject.
	Landscape	For wide, scenic photos.
	Sunset	Enhances the red hue for recording sunset images.
	Backlight	Lets you photograph a backlit image.
	Smile capture	Sets the camera to help capture the subject's smile.
	Kids	Lets you take a still image of moving children.
	Night scene	Lets you photograph a subject and capture the background at night.
	Fireworks	Slows the shutter speed to capture fireworks exploding. We recommend that you use a tripod for this.
	Snow	Lets you take beach or snow scenes.
	Food	Uses a higher color saturation to enhance the look of food.
	Building	Sharpens the image to enhance the edges of the subject.
	Text	Increases black and white contrast.

Selecting the ASM (Aperture Priority, Shutter Priority, Manual Exposure) mode:

To select the ASM mode:

- 1 Turn on your camera and set it to **record** mode.
- 2 Press the **ASM** button ① to toggle between ASM modes.



Icon	Scene mode	Description
	Program	The camera automatically makes settings suitable for the shooting conditions.
	Movie	For recording movie clips.
	Voice REC	For recording audio clips.
	Q Mode	Shows a simplified menu in a larger font.

- For **Aperture Priority**, the aperture setting appears at the bottom of the LCD.
- For **Shutter Priority**, the shutter speed appears at the bottom of the LCD.
- For **Manual Exposure** mode, both the aperture setting and the shutter speed appear at the bottom of the LCD.

For additional information on using ASM modes, see “Using ASM settings” on page 14.

Using the menus

Using the REC menu

To use the REC menu:

- 1 Turn the power on and switch to **record** mode (if necessary).
- 2 Press **MENU** (1). The *Record* menu opens.



- 3 Press ◀ or ▶ to select the icon for the menu you want. The options for that selection appear on the LCD monitor.
- 4 Press ▼ or ▲ to select the setting you want.
- 5 When you are finished making the settings you want, press the **MENU** (1) or **SET** (2) button to save the settings and exit the menu.

REC menu (still image)

Menu item	Available settings	See page
Resolution	7M ₁ / 3:2 / 16:9 / 5M ₁ / 3M ₁ / 1M ₁ / VGA ₁	12
Quality	📶 / 📶 / 📶	12
Metering	☉ / ☐ / ☉	17
White balance	Auto / ☀ / ☁ / ☀ / 🌧 / 🌧 / ☀	17
ISO	Auto, ISO50, ISO100, ISO200, ISO400, ISO800, ISO1600	17
Exposure	-2.0EV ... +2.0EV	17
Drive mode	Off / 🕒 ₂ / 🕒 ₁₀ / 🕒 _∞ / 📄	14
AEB (auto exposure bracketing)	Off / 📄	17
Highlight	Off / 📄 / 📄 / 📄	17
Sharpness	📄 / 📄 / 📄	17
Effect	Off, B&W, Sepia, Negative, Red, Green, Blue	17

Menu item	Available settings	See page
Date stamp	Off, Date, Date & Time	18
Stabilizer	Off, On	18
Face tracking	Off, On	18
Photo frame	Off, Frame 1~10	18
Digital zoom	Off, ON	13

Note

To see all available camera options, select the "P" mode in the Program menu.

REC menu (movie)

Menu item	Available settings	See page
Movie size	16:9 / 640 / 320	16
Metering	☉ / ☐ / ☉	17
White balance	Auto / ☀ / ☁ / ☀ / 🌧 / 🌧 / ☀	17

Using the Setup menu

To use the Setup menu:

- 1 Turn the power on.
- 2 Press **MENU** (1). The initial menu (Record or Playback) opens.
- 3 Press ▼, ▲, ◀, or ▶ to select **SETUP** (2), then press **SET** (3). The *Setup Menu* opens.



- 4 Press ▼ or ▲ to select the menu you want, then press **SET** (3) to open the sub-menu. The settings for that selection appear on the LCD.
- 5 Press ▼ or ▲ to select the setting you want, then press ◀ or **SET** (3) to apply the setting.
- 6 When you are finished making the settings you want, press **MENU** (1) to exit.

Setup menu

Menu item	Available settings
Sounds	Lets you set the sounds that the camera makes. <ul style="list-style-type: none"> • Shutter—Turns the shutter sound on or off. • Startup—Sets the startup sound. • Beep—Turns the operation sound on and off. • Volume—Adjusts the volume of the shutter sound, startup sound, beep, and playback sound.
Auto Review	Lets you set the time that you can review the photos you have taken. <ul style="list-style-type: none"> • Off—The captured image does not automatically display after shooting. • 1 sec.—The captured image displays for 1 second after shooting. • 3 sec.—The captured image displays for 3 seconds after shooting. • 5 sec.—The captured image displays for 5 seconds after shooting.
Power Save	Lets you set the time that the camera is idle before it turn off automatically to save power. <ul style="list-style-type: none"> • 1 min. • 3 min. • 5 min. (Does not activate in some situations. See the note on page 9.)
Date & Time	Lets you set the date and time. See “Setting the date stamp” on page 18.
Language	Lets you select a language for display menus and other information from the following languages: English, Spanish, and French.
File No.	Lets you restart numbering if you see a “Folder cannot be created” error. <ul style="list-style-type: none"> • Series—Stores the latest used file number whether deleting files or inserting a new memory card. • Reset—Resets file numbering each time the memory card is changed. Resetting the file number is useful for avoiding file name duplication when images are downloaded to a computer. (see “File naming” on page 24).
TV Out	Lets you view camera images on a television with the supplied AV cable. TV Out should be set to either NTSC or PAL, depending on your region. <ul style="list-style-type: none"> • NTSC—America, Japan, and others • PAL—Europe, Oceania, and others
USB	Lets you set the USB mode to connect the camera to a printer or a computer (See “Making connections” on page 22). <ul style="list-style-type: none"> • Computer • Printer
S. Image	Lets you select a recorded image as the startup image. (See “Choosing a startup image” on page 22.)
Format	Lets you erase all data stored on a memory card, if you are using a card, or all data stored in the internal memory, if there is no card inserted. A “BUSY...PLEASE WAIT” message displays when the format begins. A “COMPLETED” message displays when the formatting is completed. <p>Caution: All data will be deleted, including protected files. Make sure that you download important files to your computer before formatting.</p>

Menu item	Available settings
Battery Type	Lets you set the battery type to make sure that the camera displays the battery level correctly. <ul style="list-style-type: none"> • Alkaline • NiMH • Lithium • Oxide
Reset All	Lets you reset the entire menu and button operation settings to initial default settings. The following settings do not change: <ul style="list-style-type: none"> • Date & Time • Language • TV Out • Battery Type

Basic picture taking

Taking still pictures

To take still pictures:

- 1 Press **Power** to turn your camera on in **record** mode. Power turns on, the lens extends, and the power indicator LED turns green.
- 2 Compose the photo on the LCD.
- 3 Press the shutter button half way to focus the image.

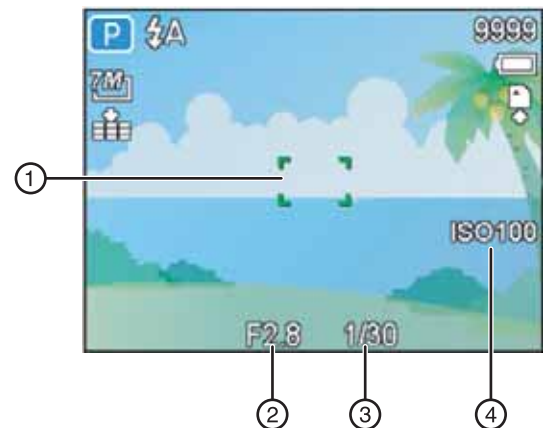

The focus area ① turns green when in focus, and the shutter speed ③, aperture value ② and ISO value ④ are displayed.

If the shutter speed is too slow, the image may be blurred. In that situation the shake warning icon !⏏ appears on the LCD monitor. To avoid a blurred photo, use a tripod to stabilize the camera.

4 Press the shutter button to take the photo.



Make sure that your fingers or the wrist strap do not block the lens.

Using Q mode

Q mode provides a simplified camera interface for beginners and those who prefer less complexity. Larger icons and fewer controls make it easier to take photos.



You can use only these basic settings in the Q mode:

Interface	Available settings
Button	Flash —Auto, Red eye, Force on, Slow sync, and Force off
	Macro —Off or On
	SET/DISP —OSD on, Guide line, or OSD off
Menu	Resolution —7M, 3:2, 16:9, 5M, 3M, 1M, or VGA
	Drive Mode —Off, 2 sec., 10 sec., Double, or Burst
	Stabilizer —Off or On
	Face Tracking —Off or On
	Photo Frame —You can only select 10 frames
	Beep —Off or On
	Auto Review —Off, 1 sec., 3 sec., or 5 sec.

These settings are pre-set and cannot be changed in Q mode:

Setting type	Pre-set to...
Fixed Note: These settings are fixed in Q mode.	<ul style="list-style-type: none"> Quality: S.Fine Highlight: Off Metering: Multi Sharpness: Normal White balance: Auto Effect: Off ISO: Auto Date Stamp: Date & Time Exposure: Auto Digital Zoom: Off AEB: Off
Utility Note: These settings are carried over from the last mode used.	<ul style="list-style-type: none"> Shutter sound File No. Startup sound TV out Power save USB Date & Time Startup image Utility setting Language

Setting image size and quality

You can select lower image resolution and quality to decrease the image size so you can take more photos before running out of memory.

Resolution values

Image size	Print size (from largest to smallest)
7M 3072 × 2304	
3:2 3072 × 2048	
16:9 3072 × 1728	
5M 2560 × 1920	
3M 2048 × 1536	
1M 1024 × 768	
VGA 640 × 480	Printing to postcards or attaching to e-mail

Quality values

Compression	Purpose	
Super Fine	High-quality images	
Fine	Acceptable quality images	
Normal	More images	
		Lower quality

Using Zoom

Your camera uses a combination of optical and digital zoom features that let you zoom in on far-away subjects or zoom out for a wide-angle shot.

The optical zoom mechanically adjusts the lens of the camera. The digital zoom uses a software process.

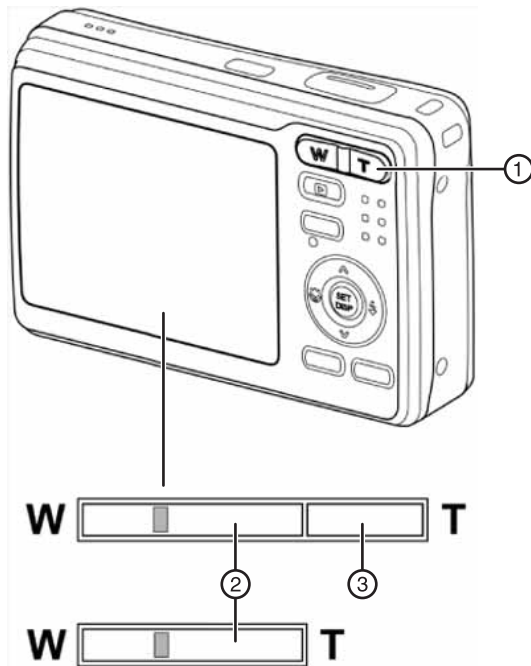

To use Zoom:

- 1 Press **Power** to turn your camera on in **record** mode. The power turns on, the lens extends, and the power indicator LED turns green.
- 2 Press the **zoom** button to compose the photo on the LCD. When the **zoom** button  is pressed, the zoom bar appears on the LCD.



Wide-angle (W)—zoom out for a wide-angle shot.

Telephoto (T)—zoom in for a telephoto shot.

- When the optical zoom  is at maximum, zooming stops temporarily. Press the **T** again the camera switches to digital zoom  automatically and zooming continues.
 - Digital zoom  is not available in movie recording.
- 3 Press the shutter button to take the photo.



Note

- Digital zoom works by enlarging the center portion of an image through a software interpolation process.
- Digital zoom achieves magnification levels up to approximately 4 times.

Using the flash

The flash is for taking photos not only for when there is insufficient light, but also when the subject is in shade or in backlight conditions. Press the flash button to cycle your camera through the various flash modes. The flash does not activate when taking continuous photos or movie recording.

To use the flash:

- 1 Press **Power** button to turn your camera on in **record** mode. The power turns on, the lens extends, and the power indicator LED turns green.
- 2 Press the **flash** button  to change the flash mode. Each time the **flash** button is pressed, the flash icon  changes.

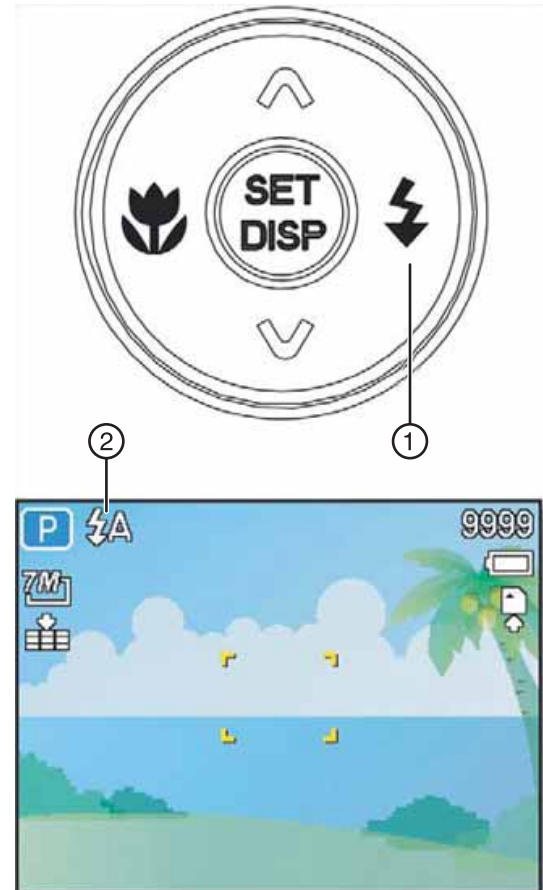

 **Auto flash**—Flash fires automatically when shooting conditions require extra lighting.

 **Red-eye reduction**—Flash strobos to let the subject's eyes adjust to the flash, then fires again to take the actual image. Your camera will detect the subject brightness and use the flash only when required.

 **Force on**—Flash fires every time you take a photo, regardless of lighting conditions.

 **Slow sync**—Flash fires with a slow shutter speed.

 **Force off**—The flash never fires even in dark situation.

- 3 Press the **shutter** button to take the photo.

Note

- The flash charging time may increase when the battery is low.
- The available flash settings are limited, depending on the REC mode you selected (see "Available functions" on page 25).

Using the macro feature

Your camera is equipped with a macro feature that lets you focus on very close subjects. In macro mode you can focus on subjects 5.9 inches (15 cm) from the lens when in the maximum wide-angle setting and 15.75 inches (40 cm) in the maximum telephoto setting.

To use the macro feature:

- 1 Press **Power** to turn your camera on in **record** mode. The power turns on, the lens extends, and the power indicator LED turns green.
- 2 Press the **macro** button ① to enter macro mode. The macro icon ② appears on the LCD monitor.

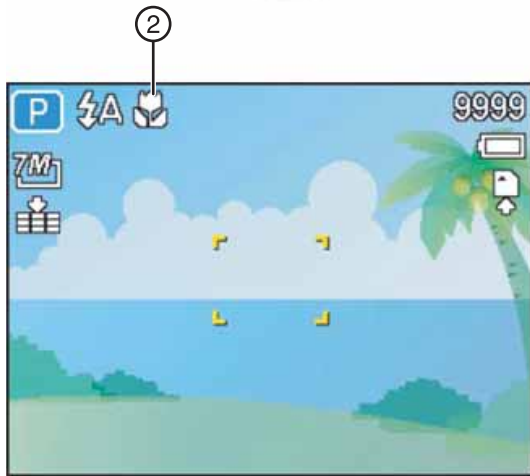

Press the **macro** button ① again to exit macro mode.

- 3 Press the **shutter** button to take the photo.

Note

Distances referred to are the distance between the camera lens surface and the subject.

Using the self-timer and burst

Use the self-timer to set a delay from the time the shutter button is pressed to the time the image is taken. Use burst to record a series of continuous still images.

To use the self-timer and burst:

- 1 Press **Power** to turn your camera on in **record** mode. The power turns on, the lens extends, and the power indicator LED turns green.

- 2 Open the **Record** menu by pressing **MENU**. The **REC** menu opens.





- 3 Press ◀ or ▶ to select the **Drive mode** icon ①. The options for Drive mode appear.

- 4 Press ▼ or ▲ to select the setting you want, then press **SET** to save the setting.

 **2 sec.**—The shutter release is delayed for two seconds.

 **10 sec.**—The shutter release is delayed for 10 seconds.

 **Double**—Press the **shutter** button for 10–12 seconds to record two images.

 **Burst**—Press and hold the **shutter** button to take a continuous series of photos. Release the shutter button to stop shooting.

- 5 Press the shutter button to take the photo.

Note

When using the self-timer, make sure that you use a tripod or place the digital camera on a level, stable surface.

Using ASM settings

Using the aperture priority setting

In this mode you can set an aperture value to match the brightness of the scenery. A higher aperture value (a smaller lens opening) brings the background into focus. Selecting a lower aperture value (a larger lens opening) lets you soften the background.

To use the aperture priority setting:

- 1 Press **Power** to turn your camera on in **record** mode. The power turns on, the lens extends, and the power indicator LED turns green.

- 2 Press the **ASM** button to toggle between ASM modes. Stop when the aperture value ① is shown.

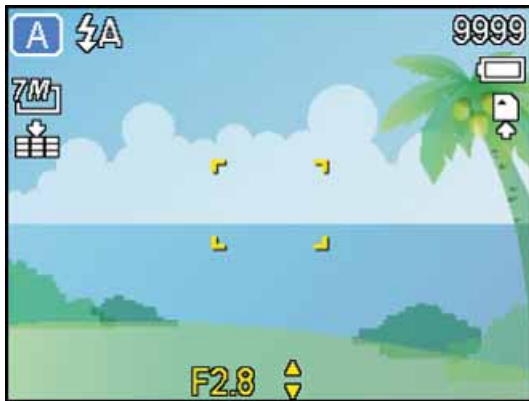

①

- 3 Press **▼** or **▲** to select the aperture setting you want. The shutter speed automatically adjusts itself for the best photo.
- 4 Press the **shutter** button to take the photo.

Note

The larger the aperture value, the smaller the lens opening, allowing less light to enter the camera.

Using the shutter priority setting

In this mode you can set a shutter speed to match the conditions. Faster shutter speeds let you take sharp photos of moving subjects, while slower speeds create a trail effect and let you shoot without a flash in dark areas.

To use the shutter priority setting:

- 1 Press **Power** to turn your camera on in **record** mode. The power turns on, the lens extends, and the power indicator LED turns green.
- 2 Press the **ASM** button to toggle between ASM modes. Stop when the shutter speed ① is shown.

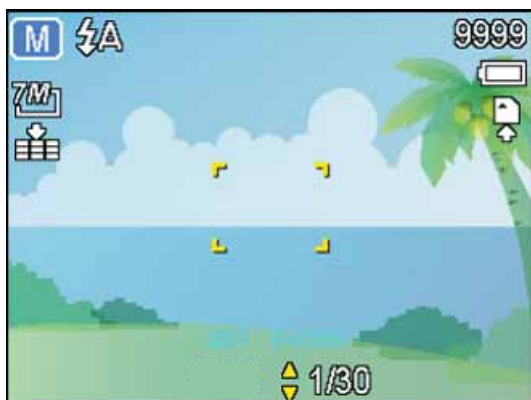

①

- 3 Press **▼** or **▲** to select the shutter speed you want. The aperture automatically adjusts itself for the best photo.
- 4 Press the **shutter** button to take the photo.

Using the manual exposure setting

In this mode you can manually set the aperture and shutter speed for a particular effect.

To use the manual exposure setting:

- 1 Press **Power** to turn your camera on in **record** mode. The power turns on, the lens extends, and the power indicator LED turns green.
- 2 Press the **ASM** button to toggle between ASM modes. Stop when the aperture and shutter speeds ① are both shown.

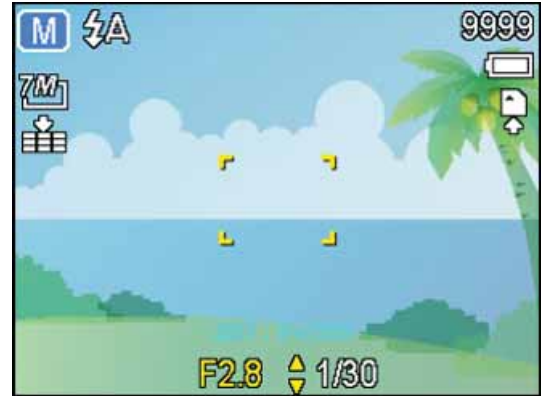

①

- 3 Press **SET** to switch between the aperture and shutter speed settings, then press **▼** or **▲** to adjust the setting.
- 4 Press the shutter button to take the photo. If you press the shutter button halfway, the difference between the standard exposure and the selected exposure appears in red.

Taking movie clips

To take movie clips:

- 1 Press **Power** to turn your camera on in **record** mode. The power turns on, the lens extends, and the power indicator LED turns green.
- 2 Press the **MODE** button. The mode palette opens.
- 3 Press **▼**, **▲**, **◀**, or **▶** to select the **Movie** icon , then press **SET** to confirm your choice.
- 4 Aim the focus area ① at the subject that you want to record. The LCD shows the recording time available ②.

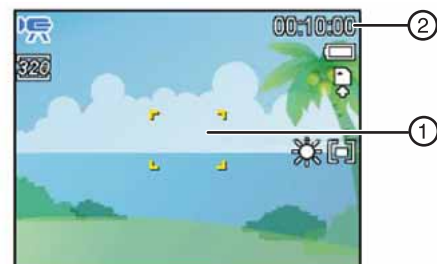

②

①

- 5 Press the shutter button ③ to start recording.

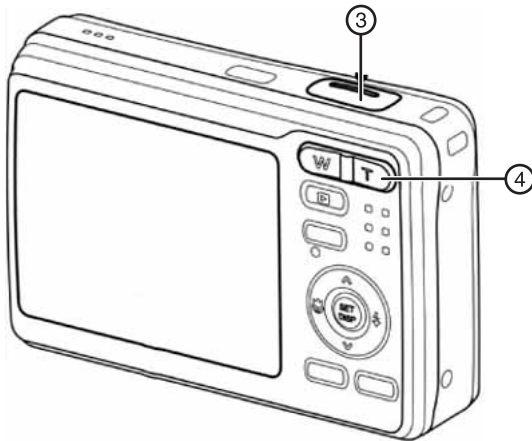

- 6 Press the zoom button ④ to adjust the image size. The white balance is set and locked to the settings of the first frame.
- 7 Press the shutter button ③ again to stop recording. The camera stops recording automatically when the memory capacity is reached.

Note

- You cannot record sound while pressing the **zoom** button.
- The digital zoom cannot be used in Movie mode.

Setting the movie size

Resolution		Frame rate	Quality
16:9	720 × 400	30 frames/sec.	Higher
640	640 × 480		↕
320	320 × 240		Lower

Recording and playing back audio clips

To record audio clips:

- 1 Press **Power** to turn your camera on in **record** mode. The power turns on, the lens extends, and the power indicator LED turns green.
- 2 Press the **MODE** button. The mode palette opens.
- 3 Press **▼**, **▲**, **◀**, or **▶** to select the **Voice REC** icon , then press **SET** to confirm your choice.
- 4 Press the shutter button to begin recording. Voices are recorded by the camera's built-in microphone. Make sure that you do not touch the microphone while recording.
- 5 Press the shutter button again to end the recording. The camera stops recording automatically when the memory capacity has been reached.

To play back audio clips:

- 1 Press **Power** to turn your camera on in **record** mode.
- 2 Press the **playback** button to switch to playback mode.
- 3 Press **◀** or **▶** to select the audio clip you want to play back.

- 4 Press **▲** to start playback.

- 5 Press **▼** to stop the audio clip, or press **▲** to pause the clip. When the audio clip is paused, press **▲** to resume playback.

Recording a voice memo

You can add a voice memo to a still photo after you take the photo.

To record a voice memo:

- 1 Press **Power** to turn your camera on in **record** mode. The power turns on, the lens extends, and the power indicator LED turns green.
- 2 Press the **playback** button to switch to playback mode.
- 3 Press **◀** or **▶** to select the still image to which you want to add a voice memo.
If the image already has a voice memo recorded, the audio clip icon  appears on the LCD monitor. If you continue to record a voice memo, the new memo replaces the existing one.
- 4 Press **MENU**. The *Playback* menu opens.



- 5 Press **▼**, **▲**, **◀**, or **▶** to select the **Voice Memo** icon , then press **SET** to confirm your choice.
- 6 Press **SET** to start recording your voice memo (for up to 30 seconds). Press **SET** again to end the recording.

Note

- You cannot add a voice memo to a movie clip or a protected image.
- You cannot delete only the voice memo.
- The voice memo is deleted when the image is deleted.

To play back a voice memo:

- 1 Press **Power** to turn your camera on in **record** mode.
- 2 Press the **playback** button to switch to **playback** mode.
- 3 Press **◀** or **▶** to select the image that has the voice memo attached.
- 4 Press **▲** to start playback.
- 5 Press **▼** to stop the voice memo, or press **▲** to pause the memo. When the voice memo is paused, press **▲** to resume playback.

Changing other settings

These settings can be made or changed on the **REC** menu. See “Using the REC menu” on page 10.

Setting the metering

Three different light metering options are available on your camera.

Option	Description
	Light is measured across the entire photo, but more importance is given to the values near the center of the photo.
	Selects an exposure, based on readings from multiple points in the photo.
	Selects an exposure based on a single reading taken from the center of your photo.

Setting the white balance

Adjusts the white balance to match different light sources such as sunlight, incandescent lighting, or fluorescent lighting.

Option	Description
AUTO	Automatically corrects the white balance. Ideal for general photography.
	Adjusts for bright sun or natural light conditions.
	Adjusts for cloudy days or twilight conditions.
	Adjusts for normal indoor lighting conditions. Corrects the orange hue from incandescent light bulbs. Ideal for indoor photos under incandescent or halogen lighting without a flash.
	Adjusts for fluorescent lighting. Corrects the green hue of fluorescent lighting. Ideal for indoor photos under fluorescent lights without a flash.
	For a more accurate adjustment, or when the light source cannot be specified.

Tip Point the camera at a white piece of paper or similar object under the lighting conditions for which you want to set the white balance, then press the **shutter** button.

Setting the ISO sensitivity

With the initial settings, the ISO sensitivity is automatically set according to the brightness of the subject.

Option	Description
Auto	Sets the ISO sensitivity automatically
ISO 50	Sets the sensitivity to ISO 50 equivalent
ISO 100	Sets the sensitivity to ISO 100 equivalent
ISO 200	Sets the sensitivity to ISO 200 equivalent
ISO 400	Sets the sensitivity to ISO 400 equivalent
ISO 800	Sets the sensitivity to ISO 800 equivalent
ISO 1600	Sets the sensitivity to ISO 1600 equivalent

Tip Higher ISO speeds increase the image “noise.” To take clean images, use as low an ISO speed as possible.

Setting the exposure

Set the exposure value manually to compensate for unusual lighting conditions such as indirect indoor lighting, dark backgrounds, and strong backlighting.

Setting the AEB (auto exposure bracketing)

Sets the auto exposure bracketing (AEB) setting to shoot three continuous images, each with a different exposure setting: correctly exposed, underexposed, and overexposed.

Setting the highlight

Make the subject stand out from its surroundings. The subject will be in focus in three different ranges: / /

Tip Photo Frame and Face Tracking features cannot be used when using the highlight feature.

Setting the sharpness

You can select whether you want the image to have sharp or soft outlines.

Option	Description
	The edges of the image are sharpened, but noise may occur in the photo.
	The edges of the images are sharp. This setting produces photos that are suitable for printing.
	The edges of the image are softened. This setting produces photos that are suitable for editing on a computer.

Setting the photo effect

You can add special effects to your images in **record** mode or in **playback** mode.

Option	Description
Off	No photo effects are added to the image
	Red eye removal (PLAYBACK only)
B&W	The image is converted to black and white
Sepia	A sepia tone is added to the image
Negative	The image is converted to a negative
Mosaic	Mosaic tiles are added to the image (playback only)
Red	A red tone is added to the image
Green	A green tone is added to the image
Blue	A blue tone is added to the image

Setting the date stamp

You can use the date stamp to add a date to your photos as you take them.

Option	Description
Off	No date or time stamp is added to your photos
Date	Only a date stamp is added to your photos
Date & Time	A date and time stamp is added to your photos

Setting the stabilizer

Increases sensitivity (ISO) and shutter speed to brighten up your photos, effectively preventing blurred images caused by hand shake or subject movement.

Setting face tracking

When you turn on face tracking, the lens locks onto the main subject in the photo and follows their movements. Also use auto digital zoom technology to retract and extend the zoom lens that lets you become the focus of lens.

Tips

- Pressing the shutter halfway down. If the AF area shows green, focus is complete.
- Face tracking is powered by Arcsoft.
- Under some environmental influences, face tracking may be limited.
- Highlight and photo frame cannot be used when using face tracking.

Using custom photo frames

You can add 10 different frames to still images to make them more interesting.

Tips

- This feature is only available with still images (except 3:2 and 16:9).
- Highlight and face tracking cannot be used when you use the a photo frame.

Viewing photos and video

Viewing photos

To view photos:

- 1 Press **Power** to turn your camera on in **record** mode.
- 2 Press the **playback** button to switch to **playback** mode.
The latest recorded photo appears on the LCD monitor. If no photos are stored, "No image" appears.
- 3 Press **◀** or **▶** to cycle through the available photos. Pressing **◀** displays the previous photo and pressing **▶** displays the next photo.

Tip

Holding down **◀** or **▶** scrolls through the photos at high speed.

Playing a slide show

To play a slide show:

- 1 Press **Power** to turn your camera on in **record** mode.

- 2 Press the **playback** button to switch to **playback** mode.



- 3 Press the **MENU** button (1), then press **▼**, **▲**, **◀**, or **▶** to select **Slide Show** and press the **SET** button (2) to confirm.
- 4 Press **▼**, **▲**, **◀**, or **▶** to set the slide show interval (1~10 seconds), effect **☑**, and repeat **↺** options.
- 5 Press the **SET** button (2) to start the slide show. During the slide show, press the **SET** button to pause the show, then press the **SET** button again to resume.

Playing movie clips

To play movie clips:

- 1 Press **Power** to turn your camera on in **record** mode.
- 2 Press the **playback** button to switch to **playback** mode.
- 3 Press **◀** or **▶** to select the movie clip you want to play.
- 4 Press **▲** to start playback.
- 5 Press **▼** to stop the audio clip, or press **▲** to pause the clip. When the audio clip is paused, press **▲** to resume playback.

Tips

During playback, press **◀** to rewind the movie, or press **▶** to fast forward.
Press the **shutter** button to capture a still photo from the movie clip while it is paused.

Viewing thumbnails

To view thumbnails:

- 1 Press **Power** to turn your camera on in **record** mode.
- 2 Press the **playback** button to switch to **playback** mode.
- 3 Press the zoom button (W). The *Thumbnail* screen opens.



- Press **▼**, **▲**, **◀**, or **▶** to select the photo you want, then press **T** or the **SET** button to view the photo in full screen.

Tip
You can protect or delete multiple photos in the Thumbnail screen. See "Editing your photos" on page 19.

Editing your photos

Rotating still photos

To rotate a photo:

- Press **Power** button to turn your camera on in **record** mode.
- Press the **playback** button to switch to **playback** mode.
- Press **◀** or **▶** to select the photo you want to rotate.

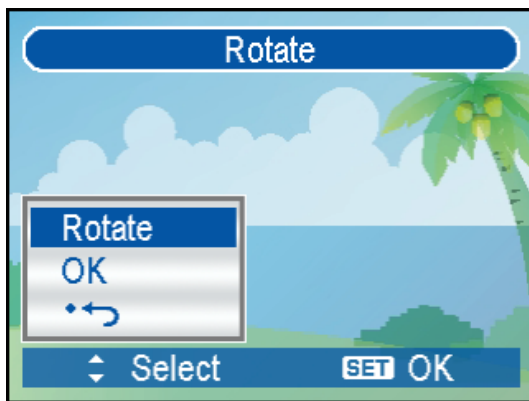

- Press the **MENU** button, then press **▼**, **▲**, **◀**, or **▶** to select **Rotate** and press **SET** to confirm.
- Press **SET** to rotate the photo. Each press rotates the photo 90° clockwise.
- Press **▼** or **▲** to select **OK**, then press **SET** again to finishing rotating.

To resize a photo:

- Press **Power** button to turn your camera on in **record** mode.
- Press the **playback** button to switch to **playback** mode.
- Press **◀** or **▶** to select the photo you want to resize.
- Press the **MENU** button, then press **▼**, **▲**, **◀**, or **▶** to select **Resize** and press **SET** to confirm.
- Press **▼** or **▲** to select a size option, then press **SET** again to finishing resizing. The resized photo is saved as a new file.

Tip
Resizing can decrease (not increase) the size of a photo.

To add special effects to a photo:

- Press **Power** button to turn your camera on in **record** mode.
- Press the **playback** button to switch to **playback** mode.

- Press **◀** or **▶** to select the photo to which you want to add the special effects.
- Press the **MENU** button, then press **▼**, **▲**, **◀**, or **▶** to select **Photo Edit** and press **SET** to confirm.
- Press **▼** or **▲** to select an effects option, then press **SET** again to finish. The edited photo is saved as a new file.

To add a photo frame to a photo:

- Press **Power** button to turn your camera on in **record** mode.
- Press the **playback** button to switch to **playback** mode.
- Press **◀** or **▶** to select the photo to which you want to add the photo frame.
- Press the **MENU** button, then press **▼**, **▲**, **◀**, or **▶** to select **Photo Frame** and press **SET** to confirm.
- Press **▼** or **▲** to select the frame you want, then press **SET** again to finish. The edited photo is saved as a new file.

Magnifying or trimming still photos

To modify or trim a still photo:

- Press **Power** button to turn your camera on in **record** mode.
- Press the **playback** button to switch to **playback** mode.
- Press **◀** or **▶** to select the photo you want to magnify or trim.



- Press **T** to magnify the photo. The photo is magnified and center area of the photo is shown. Press **▼**, **▲**, **◀**, or **▶** to view different parts of the photo, then press the **MENU** button to return the photo to normal size.

- OR -

Press the **SET** button to begin trimming, then press the **SET** button again to trim the selected photo and save it as a new file.

Copying, deleting, and protecting files

Copying files

You can copy the files from the camera's internal memory to a memory card. Make sure that you have inserted a memory card into your camera (see "Installing the memory card" on page 5).

To copy a file:

- 1 Press **Power** button to turn your camera on in **record** mode.
- 2 Press the **playback** button to switch to **playback** mode.
- 3 Press **◀** or **▶** to select the photo you want to rotate.

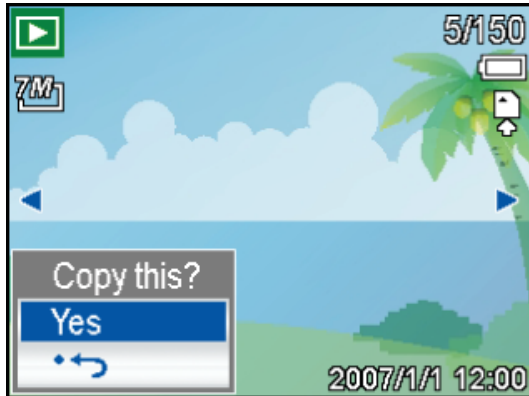

- 4 Press the **MENU** button, then press **▼**, **▲**, **◀**, or **▶** to select **Copy to card** and press **SET** to confirm.
- 5 Press **▼** or **▲** to choose **Single**, then press **SET** to confirm. If you want to copy all of the photos in the camera, select **All**.
- 6 Press **◀** or **▶** to select the photo you want to copy to the memory card, then select **Yes** and press **SET** to start the copy.
- 7 Repeat Step 6 to copy additional photos.
- 8 Press the **MENU** button to finish and exit the menu.

Deleting files

To delete single files:

- 1 Press **Power** button to turn your camera on in **record** mode.
- 2 Press the **playback** button to switch to **playback** mode.

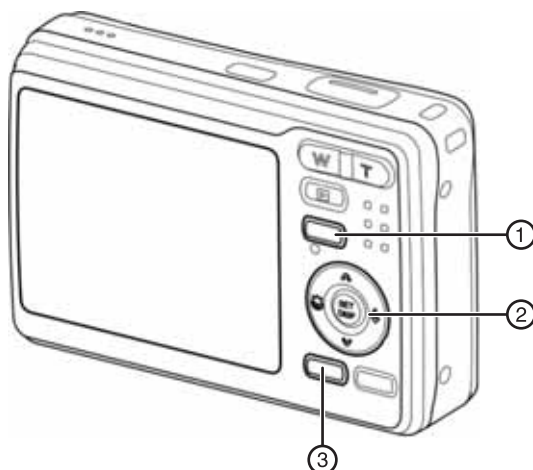

- 3 Press the **MENU** button ①, then press **▼**, **▲**, **◀**, or **▶** to select **Delete** and press **SET** ② to confirm.
- 4 Press **▼** or **▲** to select **Single**, then press **SET** ② to confirm.
- 5 Press **◀** or **▶** to select the photo want to delete, then press **SET** ② to delete the photo.

- 6 Repeat Step 5 to delete additional photos.

Tip

To quickly delete the currently displayed photo, press **Delete** (Ⓜ), then press **SET** (Ⓜ) to confirm. Protected photos cannot be deleted in this way.

To delete multiple files:

- 1 Press **Power** button to turn your camera on in **record** mode.
- 2 Press the **playback** button to switch to **playback** mode.
- 3 Press **ZOOM** (W), the *Thumbnail* screen opens.
- 4 Press the **MENU** button, then press **▼**, **▲**, **◀**, or **▶** to select **Delete** (Ⓜ) and press **SET** to confirm.



- 5 Press **▼** or **▲** to highlight **Select**, then press **SET** to confirm. The frame of the selected photo turns green.
- 6 Press **▼**, **▲**, **◀**, or **▶** to select the photos want to delete. Pressing **SET** toggles the **delete** icon (Ⓜ) on and off. Repeat until all the photos you want to delete are displayed with the **delete** icon (Ⓜ).
- 7 Press the **MENU** button, then choose **Yes** and press **SET**. All the photos you selected are deleted.
- 8 To cancel delete, press the **MENU** button again before pressing **SET**.

To delete all files:

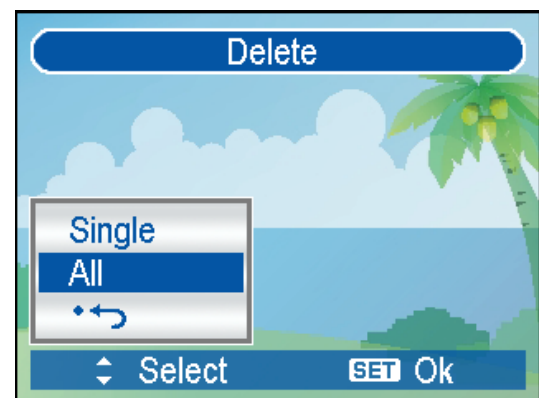

- 1 Press **Power** button to turn your camera on in **record** mode.
- 2 Press the **playback** button to switch to **playback** mode.
- 3 Press the **MENU** button, then press **▼**, **▲**, **◀**, or **▶** to select **Delete** (Ⓜ) and press **SET** to confirm.



- 4 Press **▼** or **▲** to select **All**, then press **SET** to confirm.
- 5 Press **SET** again to delete all unprotected photos.

Protecting files

To protect single files:

- 1 Press **Power** button to turn your camera on in **record** mode.
- 2 Press the **playback** button to switch to **playback** mode.
- 3 Press the **MENU** button, then press **▼**, **▲**, **◀**, or **▶** to select **Protect**  and press **SET** to confirm.
- 4 Press **▼** or **▲** to select **Single**, then press **SET** to confirm.
- 5 Press **◀** or **▶** to select the photo you want to protect, then press **SET** to protect the photo. When the photo is protected, the protect icon  is shown on the photo when it is displayed on the LCD.
- 6 Repeat Step 5 to delete additional photos.



Tip

To unprotect a photo, press the **SET** button again in Step 5. The protect icon  disappears and the photo is unprotected.

To protect multiple files:

- 1 Press **Power** button to turn your camera on in **record** mode.
- 2 Press the **playback** button to switch to **playback** mode.
- 3 Press **ZOOM** (W), the *Thumbnail* screen opens.
- 4 Press the **MENU** button, then press **▼**, **▲**, **◀**, or **▶** to select **Protect**  and press **SET** to confirm.



- 5 Press **▼** or **▲** to choose **Select**, then press **SET** to confirm. The frame of the selected photo turns green.
- 6 Press **▼**, **▲**, **◀**, or **▶** to select the photos you want to protect.
- 7 Press **SET** to toggle the **protect** icon  on and off. Repeat until all the photos you want to delete are displayed with the **protect** icon .
- 8 Press the **MENU** button, then choose **Yes** and press **SET**. All the photos you selected are protected.

- 9 To cancel protect, press the **MENU** button again before pressing **SET**.

To protect all files:

- 1 Press **Power** button to turn your camera on in **record** mode.
- 2 Press the **playback** button to switch to **playback** mode.
- 3 Press the **MENU** button, then press **▼**, **▲**, **◀**, or **▶** to select **Protect**  and press **SET** to confirm.

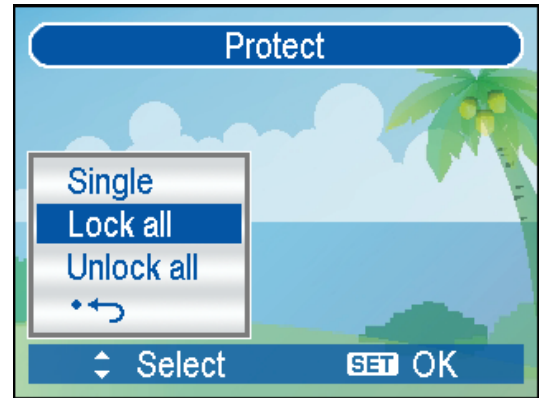

- 4 Press **▼** or **▲** to select **Lock all**, then press **SET** to confirm.
- 5 Press **SET** again to protect all photos.

Tip

To unprotect all photos, select **Unlock all** in Step 4, then press **SET**.

Additional options

Setting the Digital Print Order Format (DPOF)

The DPOF setting lets you select images on the memory card for printing and specify the number of print copies in advance using the camera. This is convenient for sending the images to a photo developing service or for printing on a direct print-compatible printer.

To set the DPOF:

- 1 Press **Power** button to turn your camera on in **record** mode.
- 2 Press the **playback** button to switch to **playback** mode.
- 3 Press the **MENU** button, then press **▼**, **▲**, **◀**, or **▶** to select **DPOF**  and press **SET** to confirm.

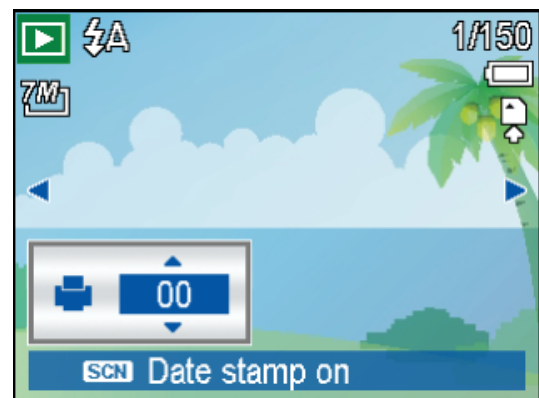

- 4 Press **▼** or **▲** to select **Single**, then press **SET** to confirm.
To set up the DPOF for all photos, select **All** in this step.
To reset all DPOF settings to initial default, select **Reset** in this step.
- 5 Press **◀** or **▶** to select the photo you want to print.
- 6 Press **▼** or **▲** to set the number of copies you want (0~30). To cancel DPOF for this photo, select **0**.
- 7 Press the **SCN** button to turn on the date stamp for the current photo. Press it again to turn off the date stamp.
- 8 Repeat Steps 5 to 7 for additional photos you want to print.
- 9 Press **SET** or the **MENU** button to apply the DPOF settings.

Choosing a startup image

To choose the startup image:

- 1 Press **Power** button to turn your camera on in **record** mode.
- 2 Press the **playback** button to switch to **playback** mode.

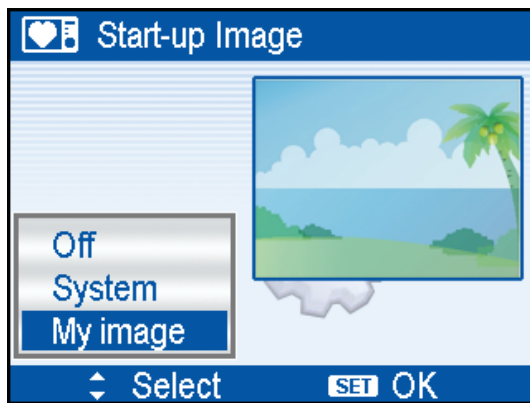

- 3 Press the **MENU** button, then press **▼**, **▲**, **◀**, or **▶** to select **S.Image** and press **SET**.
- 4 Press **◀** or **▶** to select the photo you want to use, then press **SET** to confirm. "Completed" appears on the LCD.
- 5 Press the **MENU** button, then press **▼**, **▲**, **◀**, or **▶** to select the **Setup menu** icon .
- 6 Press **▼** or **▲** to select **S.Image** , then press **▶** or **SET**.
- 7 Press **▼** or **▲** to select the option you want, then press **SET** to confirm. Options include:
 - **Off**—Disable startup image.
 - **System**—Use the camera default image.
 - **My image**—Use the image that you specified in Step 5.
- 8 Press the **MENU** button to close the menu.

Note

The startup image is stored in internal memory, so it is not deleted, even if the original image is deleted or the memory formatted.

Making connections

Connecting the camera to a TV

Use this connection to display recorded images on a television with the supplied AV cable.

To connect the camera to a TV:

- 1 Set the TV Out setting to match the TV system that you are using (See "Setup menu" on page 11).
- 2 Turn off the camera and the TV.
- 3 Connect the camera to the TV set using the supplied AV cable.

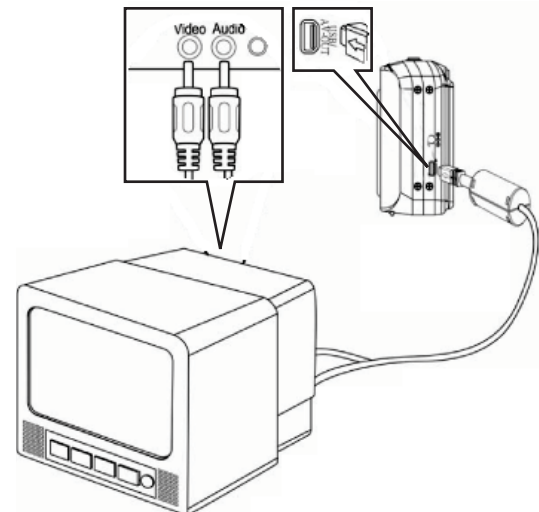

- 4 Set the TV input signal to Video In. Refer to the documentation included with your TV for more information.

Everything that would normally appear on the camera's LCD, such as photo and video clip playback, slide shows, and image or video capture, appears on the TV.

Connecting the camera to a computer

To connect the camera to a computer:

- 1 Connect the camera to the computer using the supplied USB cable. The LCD monitor turns off when the connection is successful.

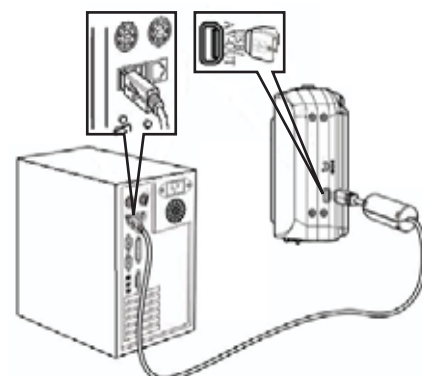

- 2 Click **My Computer** or **Windows Explorer** on your computer. A new "Removable Disk" appears in the drive list.

- Double-click **Removable Disc** to view the contents. Folders stored on the camera are located in a folder named **DCIM**.

Note

You can also move files to your computer by removing the memory card from your camera and plugging it into your PC's card reader.

Troubleshooting

Problem	Cause	Solution
Power does not turn on.	Battery is inserted incorrectly.	Reinstall the battery correctly.
	The battery is dead.	Replace or recharge the battery.
	The battery compartment is open.	Make sure that the battery compartment is closed.
The camera does not take pictures.	The flash is charging.	Wait for the flash to charge.
	The memory is full.	Insert a new memory card.
	The memory card is not formatted correctly.	The card may be defective. Install a new card.
The image is not recorded when the shutter button is pressed.	The flash is charging.	Wait for the flash to charge.
	The memory is full.	Insert a new memory card.
The flash does not fire.	The flash is set to OFF.	Set the flash to another mode.
The image is blurry or out of focus.	The camera was moving when the image was captured.	Hold the camera steady when shooting a photo.
	The subject was beyond the range of the camera's focus.	Turn macro mode ON if the subject is within 15 to 40 cm. Do not use macro mode when shooting distant subjects.
The image is not displayed on the LCD.	A memory card with non-DCIF images (recorded on another camera) is loaded.	This camera cannot display non-DCIF images.
Recorded images are not saved in memory.	The camera was turned off or powered down before the image was stored in memory.	If the low battery indicator appears on the LCD, replace the battery immediately.
Cannot transfer images to a computer after connecting the USB cable.	The USB driver is not installed.	Install the USB driver before you connect the camera to a computer and turn the camera on.
Card error	The memory card format may not be correct.	Reformat the memory card to the FAT format, using a card reader with Windows.

Specifications

Specifications are subject to change without notice.

Sensor	7 Megapixels CCD
Lens	Focal length: f/6.2 (W)~18.6 mm (T), 3X optical zoom, 4X digital zoom
LCD monitor	2.5-inch LCD monitor
Focus range	Normal: 31.5 in. (80 cm) ~ infinity Macro: (W) 5.9 in.~3.28 ft. (15 cm ~1 m) (T) 15.75 in.~3.28 ft. (40 cm~1m)
Aperture	f/2.8 (W) / f/5.2 (T)
Shutter	8~1/2000 seconds
File format	Still Image: EXIF 2.2-compatible format (JPEG compression), DCF compatible. Supports DPOF, (PictBridge available) Video: AVI Audio: WAV
Resolution	Still Image: 3072 × 2304 (7M), 3072 × 2048 (3:2), 3072 × 1728 (16:9), 2560 × 1920 (5M), 2048 × 1536 (3M), 640 × 480 (VGA) Video: 720 × 400, 640 × 480, 320 × 240
Scene mode	Program, Movie, Voice REC, Q. Mode, Portrait, Landscape, Sunset, Backlight, Smile Capture, Kids, Night scene, Fireworks, Snow, Food, Building, and Text
Sensitivity	Auto, ISO 50, ISO 100, ISO 200, ISO 400, ISO 800, ISO 1600
White balance	Auto, Daylight, Cloudy, Tungsten, Fluorescent (H), Fluorescent (L), Custom
Exposure control	-2EV to +2EV in 1/3 steps
Metering	Center-weighted, Multi, and Spot
Burst	Depends on memory capacity (no limit).
Self-timer	2 seconds, 10 seconds, and Double
Flash	Auto, Red eye reduction, Always on, Slow sync, and Always off
Photo effects	Black & White, Sepia, Negative, Mosaic, Red eye removal, Red, Green, and Blue
Storage	16 MB internal memory and SD card (not included)
TV system	NTSC/PAL
Power supply	2 AA alkaline batteries
Ambient temperature	Operating: 32°F to 104°F (0°C to 40°C) Storage: -4°F to 140°F (-20°C to 60°C)
Microphone	Built-in
Speaker	Built-in
Dimensions (W × H × T)	3.61 × 2.45 × 1 inches (91.7 × 62.3 × 25.5 mm)
Weight	Approx. .30 lb. (140 g) (w/o battery)

* Specifications subject to change without notice.

Appendix

Understanding folder and file names

Your digital camera automatically creates a directory of folders in the internal memory or memory card. It uses these folders to organize still images, movie clips, and other information.

Folder structure

Folder names begin with a three-digit number from 100 to 999, followed by "DICAM." Each folder holds up to 9999 files. If new files are created, a new folder named in sequence will be made automatically.

File naming

File names begin with "DSC1," and are followed by a four-digit number that increases sequentially. File numbering starts from 0001 when a new folder is created.

If the highest folder number is 999 and the highest file number exceeds 9999, the camera displays the warning message "Folder cannot be created." When it appears, try one of the following solutions:

- Reset the file number and plug in a new memory card.
- The folder number and file numbers are initialized and renumbered from 100 and 0001 respectively.

Note

Do not change the folder and file names on the memory card using your computer. If you do, you may be unable to play back the data using the digital camera.

Mode		Still Capture																	
		P	A	S	M														
Function		MENU																	
White Balance	Auto	◆	○	○	○	●	●	●	●	●	●	●	●	●	●	●	●	○	×
	Daylight	○	○	○	○	×	×	×	×	×	×	×	×	×	×	×	×	○	×
	Cloudy	○	○	○	○	×	×	×	×	×	×	×	×	×	×	×	×	○	×
	Tungsten	○	○	○	○	×	×	×	×	×	×	×	×	×	×	×	×	○	×
	Fluor_H	○	○	○	○	×	×	×	×	×	×	×	×	×	×	×	×	○	×
	Fluor_L	○	○	○	○	×	×	×	×	×	×	×	×	×	×	×	×	○	×
	Custom	○	○	○	○	×	×	×	×	×	×	×	×	×	×	×	×	○	×
ISO	Auto	◆	○	○	×	●	●	●	●	●	●	●	●	●	●	●	●	×	×
	50	○	○	○	○	×	×	×	×	×	×	×	×	×	×	×	×	×	×
	100	○	○	○	●	×	×	×	×	×	×	×	×	×	×	×	×	×	×
	200	○	○	○	○	×	×	×	×	×	×	×	×	×	×	×	×	×	×
	200	○	○	○	○	×	×	×	×	×	×	×	×	×	×	×	×	×	×
	400	○	○	○	○	×	×	×	×	×	×	×	×	×	×	×	×	×	×
	800	○	○	○	○	×	×	×	×	×	×	×	×	×	×	×	×	×	×
	1600	○	○	○	○	×	×	×	×	×	×	×	×	×	×	×	×	×	×

Mode		Still Capture																	
		P	A	S	M														
Function		MENU																	
Exposure	+0.3 ~ +2.0	○	○	○	×	×	×	×	×	×	×	×	×	×	×	×	×	×	×
	0EV	◆	○	○	×	●	●	●	●	●	●	●	●	●	●	●	●	×	×
	-0.3 ~ -2.0	○	○	○	×	×	×	×	×	×	×	×	×	×	×	×	×	×	×
Drive Mode	Off	◆	○	○	○	○	○	○	○	○	●	○	○	○	○	○	○	×	×
	2 sec.	○	○	○	○	○	○	○	○	○	×	○	○	○	○	○	○	×	×
	10 sec.	○	○	○	○	○	○	○	○	○	×	○	○	○	○	○	○	×	×
	Double	○	○	○	○	○	○	○	○	○	×	○	○	○	○	○	○	×	×
	Burst	○	○	○	○	○	○	○	○	○	×	○	○	○	○	○	○	×	×
AEB	Off	●	●	●	●	●	●	●	●	●	●	●	●	●	●	●	●	×	×
	On	○	○	○	×	×	×	×	×	×	×	×	×	×	×	×	×	×	×
Highlight	Off	◆	○	○	○	×	×	×	×	×	×	×	×	×	×	×	×	×	×
		○	○	○	○	×	×	×	×	×	×	×	×	×	×	×	×	×	×
		○	○	○	○	×	×	×	×	×	×	×	×	×	×	×	×	×	×
		○	○	○	○	×	×	×	×	×	×	×	×	×	×	×	×	×	×

Mode		Still Capture																		
		P	A	S	M															
Function		MENU																		
Sharpness	Hard	○	○	○	○	×	×	●	●	×	×	×	×	×	×	×	×	×	×	×
	Normal	◇	○	○	○	●	●	×	×	●	●	●	●	●	●	●	×	●	×	×
	Soft	○	○	○	○	×	×	×	×	×	×	×	×	×	×	×	×	×	×	×
Effect	Off	●	●	●	●	●	●	●	●	●	●	●	●	●	●	●	●	×	×	
	B&W	○	○	○	○	×	○	○	×	×	○	○	×	×	×	○	○	×	×	×
	Sepia	○	○	○	○	×	○	○	×	×	○	○	×	×	×	○	○	×	×	×
	Negative	○	○	○	○	×	○	○	×	×	×	○	×	×	×	○	○	×	×	×
	Red	○	○	○	○	×	○	○	×	×	○	○	×	×	×	○	○	×	×	×
	Green	○	○	○	○	×	○	○	×	×	×	○	×	×	×	○	○	×	×	×
Blue	○	○	○	○	×	○	○	×	×	×	○	×	×	×	○	○	×	×	×	
Date Stamp	Off	◇	○	○	○	×	○	○	○	○	○	○	○	○	○	○	○	○	×	×
	Date	○	○	○	○	×	○	○	○	○	○	○	○	○	○	○	○	○	×	×
	Date & Time	○	○	○	○	●	○	○	○	○	○	○	○	○	○	○	○	○	×	×
Stabilizer	Off	◇	○	○	○	○	○	○	○	○	○	○	○	○	○	○	○	○	×	×
	On	○	○	○	○	○	○	○	○	○	○	○	○	○	○	○	○	○	×	×

Mode		Still Capture																		
		P	A	S	M															
Function		MENU																		
Face Tracking	Off	◇	○	○	○	○	○	●	●	○	×	○	●	●	○	●	●	●	×	×
	On	×	○	○	○	○	○	×	×	○	●	○	×	×	○	×	×	×	×	×
Photo Frame	Off	◇	○	○	○	○	○	○	○	○	○	○	○	○	○	○	○	○	×	×
	Frame 1 ~ 10	○	○	○	○	○	○	○	○	○	×	○	○	○	○	○	○	○	×	×
Digital Zoom	Off	○	○	○	○	●	○	○	○	○	○	○	○	○	○	○	○	○	×	×
	On	◇	●	●	●	×	○	○	○	○	○	○	○	○	○	○	○	○	×	×

◇ : Factory setting ● : Default setting ○ : Available × : Not available.
 : Setting is retained even after mode switch or power off.
 : Disable function.
 : Set to [OFF] after power off.

Legal notices

FCC Part 15

This device complies with Part 15 of the FCC Rules. Operation of this product is subject to the following two conditions: (1) this device may not cause harmful interference, and (2) this device must accept any interference received, including interference that may cause undesired operation.

This equipment has been tested and found to comply within the limits for a class B digital device, pursuant to Part 15 of the FCC Rules. These limits are designed to provide reasonable protection against harmful interference in a residential installation. This equipment generates, uses, and can radiate radio frequency energy and, if not installed and used in accordance with the instructions, may cause harmful interference to radio communications. However, there is no guarantee that interference will not occur in a particular installation. If this equipment does cause harmful interference to radio or television reception, which can be determined by turning the equipment off and on, the user is encouraged to try to correct the interference by one or more of the following measures:

- Reorient or relocate the receiving antenna.
- Increase the separation between the equipment and receiver.
- Connect the equipment into an outlet on a circuit different from that to which the receiver is connected.
- Consult the dealer or an experienced technician for help.

FCC warning

Changes or modifications not expressly approved by the party responsible for compliance with the FCC Rules could void the user's authority to operate this equipment.

Canada ICES-003 statement

This Class B digital apparatus complies with Canadian ICES-003.

One-Year Limited Warranty

Insignia Products ("Insignia") warrants to you, the original purchaser of this new **NS-DSC7B-09** ("Product"), that the Product shall be free of defects in the original manufacture of the material or workmanship for a period of one (1) year from the date of your purchase of the Product ("Warranty Period"). This Product must be purchased from an authorized dealer of Insignia brand products and packaged with this warranty statement. This warranty does not cover refurbished Product. If you notify Insignia during the Warranty Period of a defect covered by this warranty that requires service, terms of this warranty apply.

How long does the coverage last?

The Warranty Period lasts for 1 year (365 days) from the date you purchased the Product. The purchase date is printed on the receipt you received with the Product.

What does this warranty cover?

During the Warranty Period, if the original manufacture of the material or workmanship of the Product is determined to be defective by an authorized Insignia repair center or store personnel, Insignia will (at its sole option): (1) repair the Product with new or rebuilt parts; or (2) replace the Product at no charge with new or rebuilt comparable products or parts. Products and parts replaced under this warranty become the property of Insignia and are not returned to you. If service of Products or parts are required after the Warranty Period expires, you must pay all labor and parts charges. This warranty lasts as long as you own your Insignia Product during the Warranty Period. Warranty coverage terminates if you sell or otherwise transfer the Product.

How to obtain warranty service?

If you purchased the Product at a retail store location, take your original receipt and the Product to the store you purchased it from. Make sure that you place the Product in its original packaging or packaging that provides the same amount of protection as the original packaging. If you purchased the Product from an online web site, mail your original receipt and the Product to the address listed on the web site. Make sure that you put the Product in its original packaging or packaging that provides the same amount of protection as the original packaging.

To obtain in-home warranty service for a television with a screen 25 inches or larger, call 1-888-BESTBUY. Call agents will diagnose and correct the issue over the phone or will have an Insignia-approved repair person dispatched to your home.

Where is the warranty valid?

This warranty is valid only to the original purchaser of the product in the United States, Canada, and Mexico.

What does the warranty not cover?

This warranty does not cover:

- Customer instruction
- Installation
- Set up adjustments
- Cosmetic damage
- Damage due to acts of God, such as lightning strikes
- Accident
- Misuse
- Abuse
- Negligence
- Commercial use
- Modification of any part of the Product

This warranty also does not cover:

- Damage due to incorrect operation or maintenance
- Connection to an incorrect voltage supply
- Attempted repair by anyone other than a facility authorized by Insignia to service the Product
- Products sold as is or with all faults
- Consumables, such as fuses or batteries
- Products where the factory applied serial number has been altered or removed

REPAIR REPLACEMENT AS PROVIDED UNDER THIS WARRANTY IS YOUR EXCLUSIVE REMEDY. INSIGNIA SHALL NOT BE LIABLE FOR ANY INCIDENTAL OR CONSEQUENTIAL DAMAGES FOR THE BREACH OF ANY EXPRESS OR IMPLIED WARRANTY ON THIS PRODUCT, INCLUDING, BUT NOT LIMITED TO, LOST DATA, LOSS OF USE OF YOUR PRODUCT, LOST BUSINESS OR LOST PROFITS. INSIGNIA PRODUCTS MAKES NO OTHER EXPRESS WARRANTIES WITH RESPECT TO THE PRODUCT, ALL EXPRESS AND IMPLIED WARRANTIES FOR THE PRODUCT, INCLUDING, BUT NOT LIMITED TO, ANY IMPLIED WARRANTIES OF AND CONDITIONS OF MERCHANTABILITY AND FITNESS FOR A PARTICULAR PURPOSE, ARE LIMITED IN DURATION TO THE WARRANTY PERIOD SET FORTH ABOVE AND NO WARRANTIES, WHETHER EXPRESS OR IMPLIED, WILL APPLY AFTER THE WARRANTY PERIOD. SOME STATES, PROVINCES AND JURISDICTIONS DO NOT ALLOW LIMITATIONS ON HOW LONG AN IMPLIED WARRANTY LASTS, SO THE ABOVE LIMITATION MAY NOT APPLY TO YOU. THIS WARRANTY GIVES YOU SPECIFIC LEGAL RIGHTS, AND YOU MAY ALSO HAVE OTHER RIGHTS, WHICH VARY FROM STATE TO STATE OR PROVINCE TO PROVINCE.

Contact Insignia:

For customer service please call 1-877-467-4289
www.insignia-products.com

Distributed by Best Buy Purchasing, LLC
7601 Penn Avenue South, Richfield, Minnesota, U.S.A.
55423-3645

© 2008 Best Buy Enterprise Services, Inc.
All rights reserved. INSIGNIA is a trademark of Best Buy Enterprise Services, Inc. Registered in some countries. All other products and brand names are trademarks of their respective owners.

INSIGNIA™

www.insignia-products.com (877) 467-4289

Distributed by Best Buy Purchasing, LLC
7601 Penn Avenue South, Richfield, MN USA 55423-3645
© 2008 Best Buy Enterprise Services, Inc.

All rights reserved. INSIGNIA is a trademark of Best Buy Enterprise Services, Inc. Registered in some countries.
All other products and brand names are trademarks of their respective owners.

ENGLISH
08-1356