

# AP669 Ceiling Mount Detector Installation Sheet

## Selecting a mounting location

Install the detector so that the expected movement of an intruder will be across the fields of view. This is the direction best suited for PIR detectors.

Avoid possible false alarm sources such as:

- Direct sunlight onto the detector
- Heat/cold sources in a field of view (heaters, air conditioning, radiators, etc.)
- Moving objects in the field of view (fans, pets, etc.)
- Obscuring the detector field of view with large objects, such as furniture

**Caution:** Increasing mounting heights beyond the specified range will reduce sensitivity.

## Mounting instructions

Figure 1: Mounting

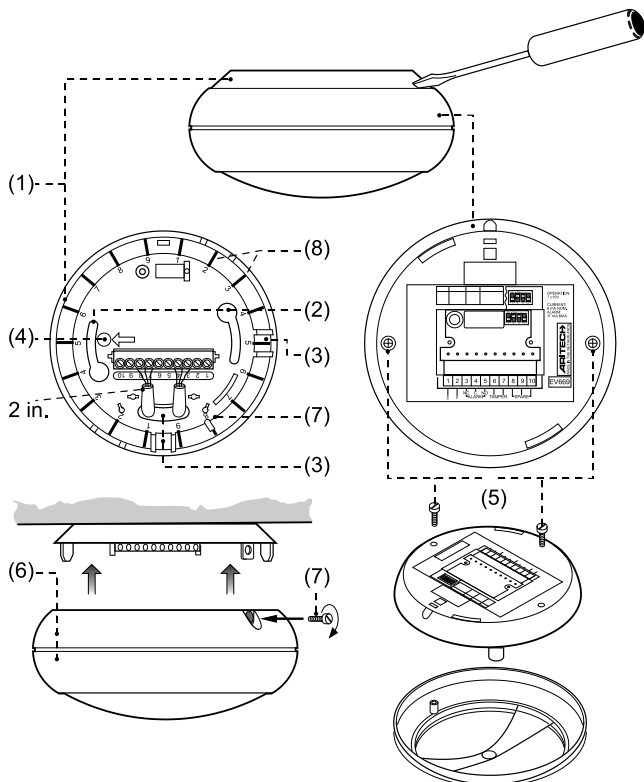

1. Lift off mounting plate (item 1) as shown in Figure 1. Fasten the mounting plate to the ceiling in the required position using mounting holes (item 2).

The detection pattern can be adjusted by up to  $\pm 15^\circ$  ( $30^\circ$  max.) by rotation of the mounting plate prior to tightening the screws.

2. Strip outer jacket approximately 2 inches (50 mm) and pull it through the cable entry hole (item 3) and strain relief.
3. Wire the detector and select the appropriate processing options as shown in Figure 2 and replace the sensor module (item 6).
4. To mount the sensor module to the mounting plate use the screw (item 7), which is placed for transport in the mounting plate.

The curtain directions 1 to 9 clockwise (item 8) are indicated in the mounting plate (curtain number 5 is the center curtain.)

## Connection and programming

Figure 2: Connections and default DIP switch settings

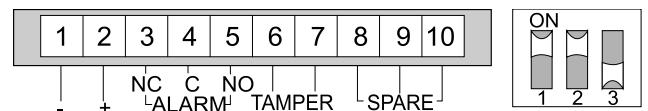

Table 1: DIP switches

Switch	Description	On	Off
1	LED enable	LED on	LED off
2	Processing	Bi-curtain	Standard-4D
3	Detection pattern	180°	360°

### Switch 1: Programming the LED

ON: LED enabled.

OFF: LED disabled.

### Switch 2: Programming the processing

ON: Enables Bi-curtain processing designed for harsh environment.

OFF: Provides the standard 4D processing.

### Switch 3: Programming the detection pattern

ON: Provides a 180° field of view for special applications.

OFF: Gives the normal 360° field of view.

**Note:** An arrow in the mounting plate (4) (see Figures 1 and 3) and inside the sensor module shows the always active coverage pattern. The coverage pattern opposite to the arrow can be disabled by setting switch 3 in the ON position.

Figure 3: Coverage pattern

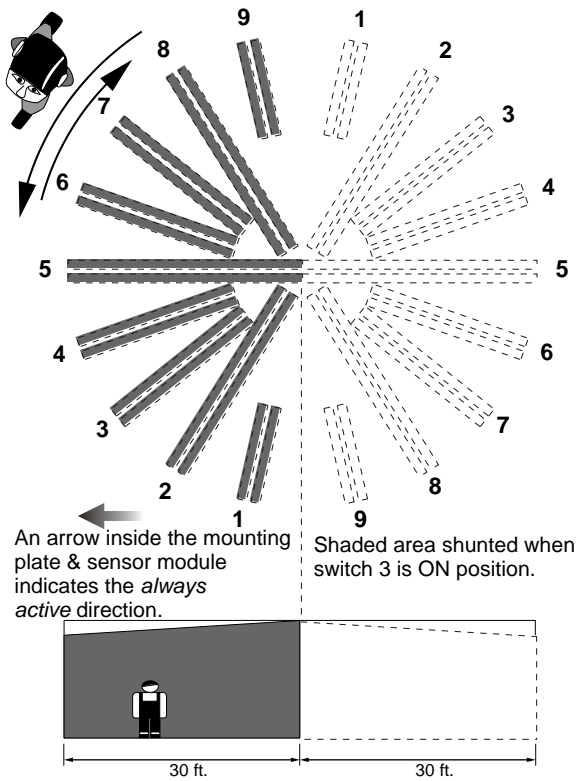

#### Access to the mirror inside the sensor module

This access is only required when masking individual curtains. Undo the screw (item 5) and open the sensor module (item 6) (see Figure 1).

Two mirrors are accessible now.

#### Selecting the coverage patterns

Mask the appropriate mirror curtains with the adhesive labels provided and reassemble the sensor module.

For example, see Figure 4 for mirror curtain coverage pattern corresponding to curtain 4 and 8 masked.

Figure 4: Coverage pattern masking

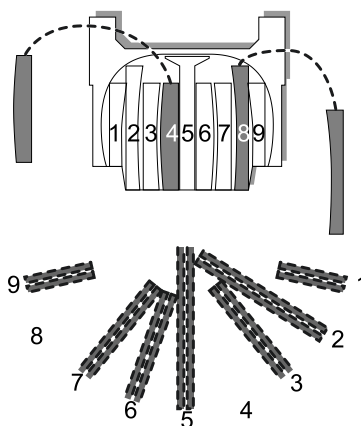

#### Mounting height application note

When increased mounting heights are used outside the specified mounting height range of 8–16 ft. (2.4–4.8 m), sensitivity will be reduced.

Figure 5: Field of view

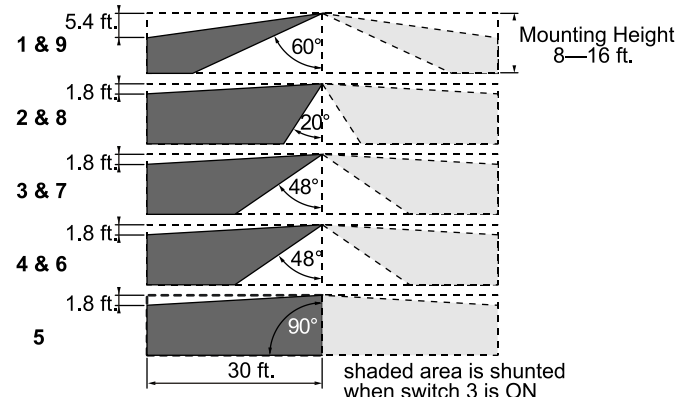

#### Specifications

Input power	12 VDC nom.
Peak to peak ripple	2 V max. (at 12 V)
Current consumption:	
Normal operation	9 mA (at 12 V)
Alarm	15 mA max. (at 12 V)
Specified mounting height	8–16 ft. (2.4–4.8 m)
Target speed range	0.9 to 12.0 ft./s
Alarm output	50 mA at 28 V, Form C
Alarm time	2.5 s min.
Tamper output	100 mA at 28 V
Temperature limit	+14 to 131°F (-10 to +55°C)
Relative humidity	93% max.
Size	Ø5.43 in. x 2.68 in. (Ø138 mm x 68 mm)
Weight	4.25 ounces
Number of curtains	18
Max. detection range	60 ft. (18 m) diameter, 30 ft. (9 m) radius

#### Regulatory information

Manufacturer UTC Fire & Security Americas Corporation, Inc.  
3211 Progress Drive, Lincolnton, NC, 28092, USA

Authorized EU manufacturing representative:  
UTC Fire & Security B.V.  
Kelvinstraat 7, 6003 DH Weert, Netherlands

#### Contact information

[www.utcfireandsecurity.com](http://www.utcfireandsecurity.com) or [www.interlogix.com](http://www.interlogix.com)

For customer support, see [www.interlogix.com/customer-support](http://www.interlogix.com/customer-support)