

Complete RTF Airplane



skyflyer^{rc}

Radio-Control
Ready-to-fly

- Quiet Electric Flight.
- Radio-Controlled Model.
- Requires 8 (AA) Batteries for Controller.
- Requires 6 (D) Batteries for Charger.



INTRODUCTION

Congratulations on the purchase of your Air-Tech Skyflyer. Your new aircraft is designed to be easy to fly and to survive the learning curve associated with new R/C pilots. But, as with any sophisticated device, you must learn how to operate it and care for it. Please read this manual thoroughly and take the time to watch the instructional video CD. Be sure to assemble your aircraft only under adult supervision.

SAFETY

The Skyflyer is a sophisticated model aircraft and should be treated as such. Improper use or assembly could cause damage to you, bystanders and / or property. Please follow all safety precautions and assembly instructions listed within this manual and on the included CD.

WARRANTY

Interactive Toy Concepts guarantees your Skyflyer to be free from manufacturing defects for a period of 90 days from date of purchase. This warranty does not cover any modifications or parts damaged by the owner. In no case will Interactive Toy Concepts' liability exceed the original cost of the kit. Interactive Toy Concepts reserves the right to change this warranty without notice. Interactive Toy Concepts assumes no liability over final assembly or for any damage resulting from the use of this product. If the buyer is not prepared to accept liability associated with use of the Skyflyer, he/she should return it in unused condition to the place of purchase.

Learning to Fly

We strongly recommend that you seek the help of an experienced R/C pilot to help you to learn to fly the Skyflyer. While the Skyflyer is designed as a training aircraft with docile flight characteristics, instruction by an experienced Pilot will make the learning experience much more enjoyable and lessen the risk of damage to your new aircraft. We suggest that you join a local R/C club - your local hobby shop will be able to help you to find one.

Additionally, you can contact one of the national R/C model associations.

In the USA:
The Academy of Model Aeronautics
5151 East Memorial Drive
Muncie, IN 47302
Tel: (800) 435-9262
Fax: (765) 741-0057
www.modelaircraft.org

In Canada:
Model Aeronautics Association of Canada
Unit 9, 5100 South Service Road
Burlington, Ontario, Canada L7L 6A5
Tel: (905) 632-9808
Fax: (905) 632-3304
www.maac.ca

Basic Safety Precautions

- 1) Carefully follow all assembly instructions. Do not modify the aircraft; this will void your warranty.
- 2) Test your aircraft before every flight. All systems must function correctly and the aircraft itself must be structurally sound. Ensure that all components are securely attached to the aircraft.
- 3) The Skyflyer is designed to fly in low wind conditions only. Do not attempt to fly it when wind speeds exceed 5 mph (8 km/h).
- 4) Always fly in large open areas only. Do not fly the model near people, cars, buildings, trees, overhead wires or other obstructions.

5) Ensure that the transmitter has fresh batteries and that the onboard battery pack is fully charged before attempting to fly.

6) Always range-check your transmitter prior to every flight.

Glossary

Motors: The Skyflyer has 3 motors - one larger central motor for main thrust and two smaller steering motors mounted on either side of the central drive motor, used to alter the flight path of the aircraft.

Electronic Speed Control: Also referred to as an ESC, the speed control sends electric current to the motors causing them to spin the propellers. It also regulates the amount of current sent to the outer motors when you want to turn the aircraft.

Battery Pack: The Skyflyer comes with a 280 mAh NiMH rechargeable battery that is used to power the electric motors and receiver. Flight time is approximately 7 minutes on a full charge.

Transmitter: The radio control transmitter allows you to control the aircraft's rate of climb, descent and flight direction. The left stick controls throttle and the right stick causes the aircraft to turn left or right.

Charger: The included portable charger uses 6 "D" size alkaline batteries to charge the NiMH battery pack. Plug in the 280 mAh flight battery pack and set the timer for 15 minutes. Do not allow the battery to get hot.

Elevator: The horizontal fin at the rear of the aircraft.

Rudder: The vertical fin at the rear of the aircraft.

Flying Your Skyflyer

NOTE: We strongly suggest that you ask an experienced R/C model pilot to help you learn to fly your aircraft. Almost all R/C clubs have flight instructors who will be happy to teach you.



UM-13201-20607

Airframe Parts & Hardware

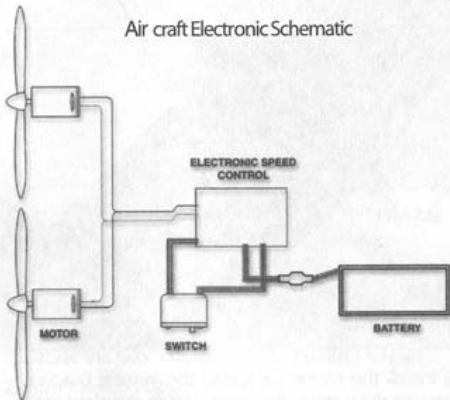
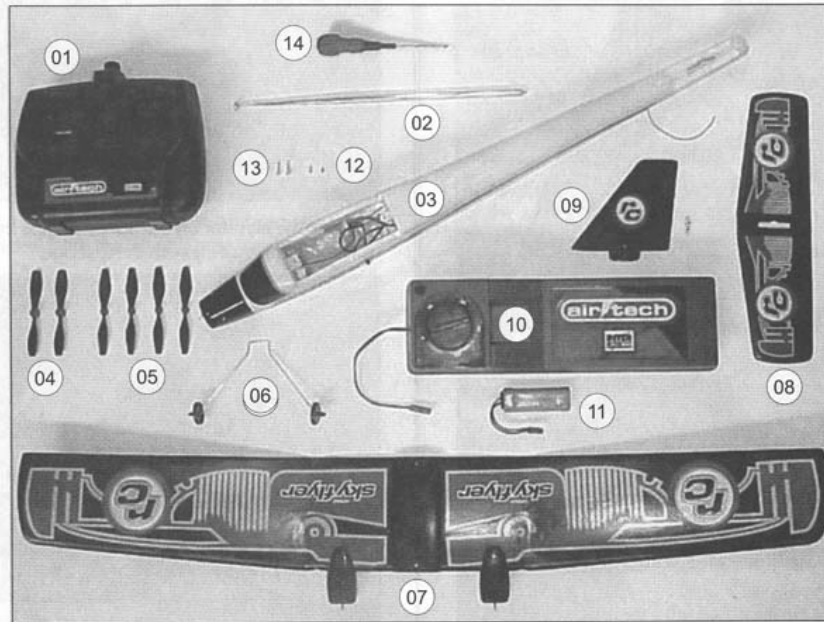

Your Skyflyer package contains the following:

- 01 - Transmitter
- 02 - Transmitter antenna
- 03 - Fuselage
- 04 - Large propellers (x2)
- 05 - Small propellers (x4)
- 06 - Landing gear
- 07 - Wing
- 08 - Elevator
- 09 - Rudder
- 10 - Charger
- 11 - NiMH battery pack
- 12 - Small screws for rudder and landing gear (x2)
- 13 - Large screws for the wing (x2)
- 14 - Small "Phillips" screwdriver
- 15 - Instructional CD or coupon (not shown)

Elevator and Rudder Assembly:

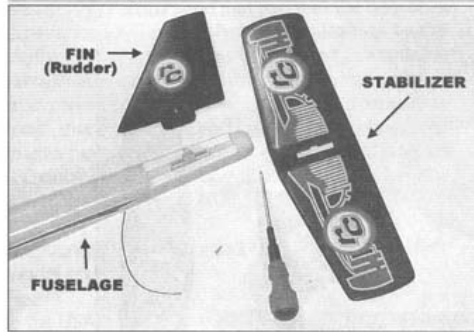

1) Locate the elevator, rudder and small "Phillips" screwdriver.

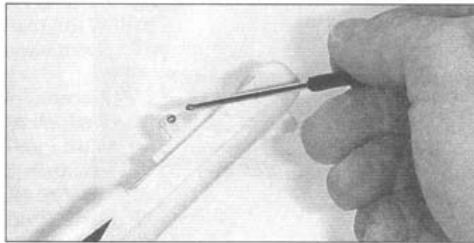

2) Remove the small screw that is pre-installed in the rudder attachment bracket.

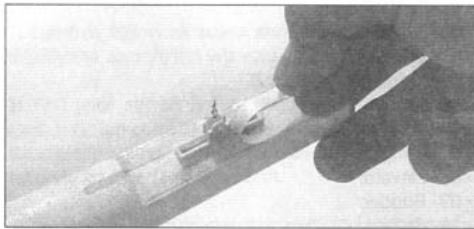

3) Remove the backing from the double-sided tape that is pre-mounted on the rear of the fuselage.

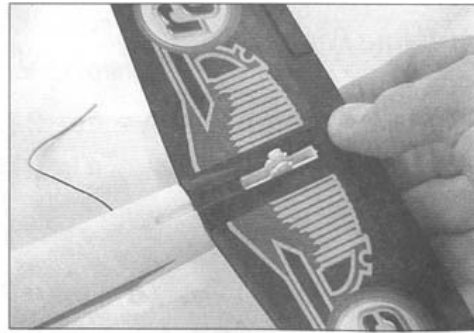

4) Place the elevator on the adhesive tape being careful to align it squarely with the fuselage.



5) Press the vertical rudder fin into the bracket being careful not to break it.



6) Install the screw back into the vertical bracket - through the rudder. Be careful not to overtighten the screw, thus stripping the threads or crushing the rudder fin.

Install the Landing Gear

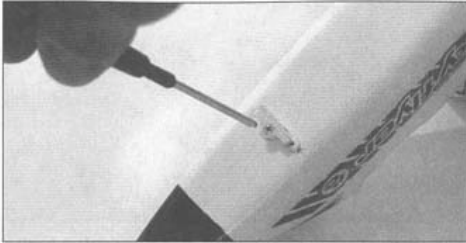

1) Turn the fuselage upside down and remove the "Phillips" screw from the landing gear mount plate.

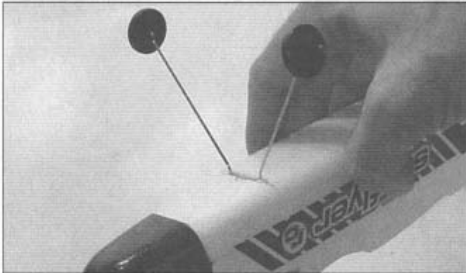

2) Insert the landing gear into the landing gear slot.

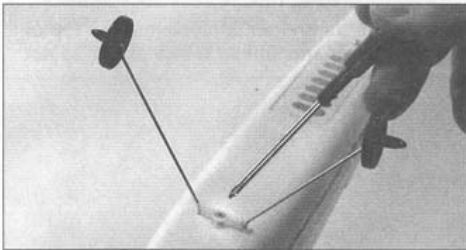

3) Replace the landing gear mount plate and reinstall the screw being careful not to overtighten it.

Install the Wing

- 1) Locate the two "Phillips" wing-mounting screws.
- 2) Turn the wing upside down.
- 3) Gently pull out the (unconnected) plug located within the fuselage.

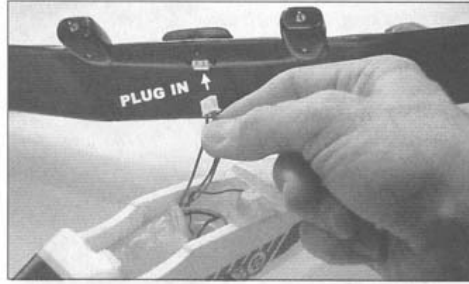

4) Insert the plug into the socket located at the front of the wing's center section. Note that the plug will only fit one way.



5) Turn the wing right-side-up and place it on the fuselage.

6) Attach the wing with the two "Phillips" screws. Be careful not to overtighten them and damage the foam material of the wing.

Install the Propellers

- 1) Locate one large and two small propellers.
- 2) Press fit the large propeller onto the center motor and the smaller propellers onto the smaller steering motors (located on either wing).

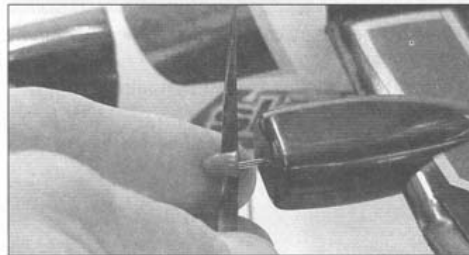

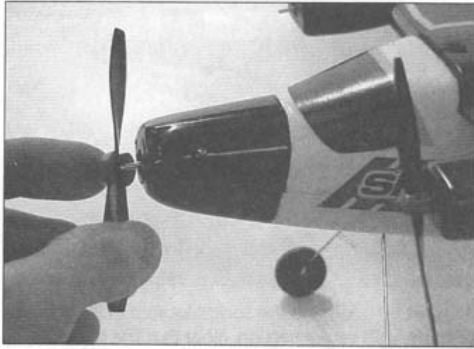

3) Be sure to leave at least a 1/16" gap between the propeller and the front of the motor covers to prevent binding.

4) Note that the central motor is mounted so that it is angled down and to the right. Do not attempt to change this angle - it is necessary to overcome the torque of the motor and allow the aircraft to fly straight.

Prepare the Transmitter

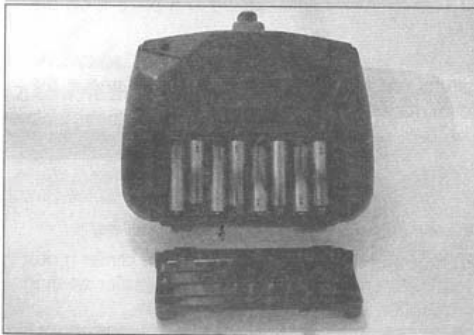

- 1) Remove the battery cover located at the rear of the transmitter.
- 2) Install 8 AA alkaline batteries ensuring that the polarities are correct.
- 3) Reinstall the battery hatch.



4) Turn the transmitter on and make sure that both the red and green LEDs light up. If only the red one is lit, you must replace the batteries with fresh ones prior to flying or your control range will be dangerously limited.

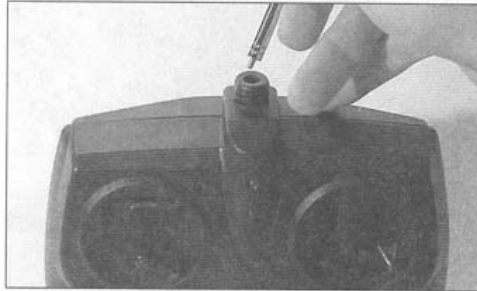

5) Insert the transmitter antenna into the top of the transmitter and thread it into place. Do not overtighten.

Charge the Onboard Battery Pack



- 1) Remove the top-mounted cover from the charger.

UM-13201-20607