

# ***TELECRANE* F22 Radio Remote Controls**

## **Product Manuals**

for

**Handheld and Joystick Models**

**August 1, 2004  
Revision 3.0.1**

**Intercontinental Technologies, Ltd.**

**558-2 Plate Drive  
East Dundee, IL 60118**

**Phone: (847) 426-9597**

**Fax: (847) 426-9724**

**[www.telecrane.com](http://www.telecrane.com)**

## **FCC and Industry Canada Approval Information**

The following information applies to transmitters:

This device complies with part 15 of the FCC Rules and RSS-210 of Industry Canada. Operation is subject to the following two conditions: (1) This device may not cause harmful interference, and (2) this device must accept any interference received, including interference that may cause undesired operation.

Changes or modifications not expressly approved by Intercontinental Technologies, Ltd. could void the user's authority to operate equipment.

Ce dispositif est conforme aux normes CNR-210 d'Industrie Canada et la partie 15 des règles de la FCC. L'utilisation de ce dispositif est autorisée seulement aux conditions suivantes: 1) il ne doit pas produire de brouillage et 2) l'utilisateur du dispositif doit être prêt à accepter tout brouillage radioélectrique reçu, même si ce brouillage est susceptible de compromettre le fonctionnement du dispositif .

This equipment has been tested and found to comply with the limits for a Class A digital device, pursuant to Part 15 of the FCC Rules. These limits are designed to provide reasonable protection against harmful interference when the equipment is operated in a commercial environment. This equipment generates, uses, and can radiate radio frequency energy and, if not installed and used in accordance with the instruction manual, may cause harmful interference to radio communications. Operation of this equipment in a residential area is likely to cause harmful interference in which case the user will be required to correct the interference at his own expense.

The following information applies to receivers:

Models F22-2D, F22-2D1, F22-2S, F22-2S1, F22-4D, F22-4D1, F22-4S, F22-4S1, F22-6D, F22-6D1, F22-6S, F22-6S1, F22-12D, F22-10D1, F22-12S, F22-10S1, F22-J:



Tested to comply with FCC standards

“For home or office use”

## Table of Contents

### Part 1: Operator's Manual

Chapter 1	Warranty .....	1
1.1	Warranty .....	1
1.2	Warranty Period .....	1
1.3	Warranty Service .....	1
1.4	Disclaimers .....	1
1.5	Warranty Contact Information .....	2
Chapter 2	Safe Operation .....	3
2.1	Emergency Procedures .....	3
2.2	General Safety Information .....	3
2.3	Installation Safety .....	3
2.4	Operational Safety .....	3
2.5	Safety When Performing User Maintenance .....	4
Chapter 3	Overview of Parts and Features .....	5
3.1	Large Chassis Mini-Style Transmitter .....	5
3.2	Small Chassis Mini-Style Transmitter .....	6
3.3	N1-Style Transmitter .....	6
3.4	Typical Receiver for Handheld Models .....	7
3.5	Transmitter for the Model F22-J Joystick Controller .....	8
3.6	Receiver for the Model F22-J Joystick Controller .....	9
Chapter 4	Operation of the F22 Series Industrial Radio Remote Controller .....	11
4.1	Normal Operation of the Handheld and Joystick Models .....	11
4.2	Special Functions of Handheld Models .....	14
4.3	Special Functions of Joystick Models .....	15
Chapter 5	User Maintenance .....	17
5.1	Safety Aspects of User Maintenance .....	17
5.2	Unusual Alarms .....	17
5.3	Battery Changing Procedure (Handheld Models) .....	17
5.4	Battery Changing Procedure (Joystick Models) .....	17
Chapter 6	Basic Troubleshooting .....	19
6.1	Reliability .....	19
6.2	Self-Diagnostics and Error Codes .....	19
6.3	User Troubleshooting .....	19
Chapter 7	Safe Installation .....	21
7.1	Emergency Procedures .....	21
7.2	General Safety Information .....	21
7.3	Installation Safety .....	21
Chapter 8	Installation .....	23
8.1	Transmitter Installation .....	23
8.2	Receiver Installation .....	23
8.3	Installation of Optional Accessories .....	24

Chapter 9	Programming By Computer.....	25
9.1	Overview.....	25
Chapter 10	Function Settings.....	27
10.1	Description.....	27
10.2	F22 Series Handheld Transmitter Function Settings .....	27
10.3	F22 Series Joystick Transmitter Function Settings.....	30
10.4	F22 Handheld Series Receiver Function Settings.....	31
10.5	F22-J Receiver Function Settings .....	32
Chapter 11	Alarm Codes.....	35
Chapter 12	Principles of Operation of Major Subcomponents.....	39
12.1	Transmitter.....	39
12.2	Receiver .....	40
Chapter 13	Customer-Specific Information .....	43
13.1	Serial Numbers and Security Codes .....	43
13.2	Function Settings .....	43
Chapter 14	Product Technical Sheets .....	45
14.1	F22 Series Systems .....	45
14.2	F22 Transmitter and Receiver Part Numbers.....	46
14.3	F22 Series: Accessories .....	46
14.4	Extended Antenna Kit.....	47
14.5	Technical and Programming Sheets.....	48

**Table of Figures**

FIGURE 1: F22-12D TRANSMITTER..... 5  
FIGURE 2: F22-6D TRANSMITTER..... 6  
FIGURE 3: F22-10S1 TRANSMITTER ..... 6  
FIGURE 4: TYPICAL RECEIVER FOR HANDHELD MODELS (FRONT AND BACK) ..... 7  
FIGURE 5: F22-J JOYSTICK TRANSMITTER (TOP AND BOTTOM)..... 8  
FIGURE 6: F22-J RECEIVER (FRONT AND BACK) ..... 9  
FIGURE 7: EMS BUTTON AND START KEY ..... 12  
FIGURE 8: ENCODER/BUTTON PCB ..... 39  
FIGURE 9: TRANSMITTER RF MODULE ..... 39  
FIGURE 10: LED PRINTED CIRCUIT BOARD ON JOYSTICK RECEIVER ..... 40  
FIGURE 11: LOCATION OF RUN/TEST SWITCH IN RECEIVER FOR HANDHELDS ..... 41  
FIGURE 12: LOCATION OF RUN/TEST SWITCH IN RECEIVER FOR JOYSTICK..... 42  
FIGURE 13: PROGRAMMING SHEET LEGEND ..... 48

**THIS PAGE INTENTIONALLY LEFT BLANK**

## Part 1: Operator's Manual

### Chapter 1    Warranty

#### 1.1    Warranty

Intercontinental Technologies, Ltd. (ITL) guarantees that this product meets its published specifications at the time of shipment.

#### 1.2    Warranty Period

This equipment is warranted against defects in material and manufacturing for a period of **one year** from the date of shipment. During the warranty period, ITL will repair or replace defective components at no charge, if the failure of the product was due to defective material or manufacturing.

#### 1.3    Warranty Service

For warranty service, this product must ultimately be returned to ITL. The buyer must pay shipping charges to the ITL service facility, and ITL will pay return shipping charges. Warranty service on F22 units shall be provided by ITL only and ITL will not be responsible for service or repair costs charged by third parties.

Your Distributor is:	Your ITL service facility is located at:  <b>558-2 Plate Drive</b> <b>East Dundee, IL 60118</b>  phone: (847) 426-9597
----------------------	---

#### 1.4    Disclaimers

- ITL will not be liable for any damage to the warranted product, and no other warranty is expressed or implied, except as explicitly described.
- ITL does not warranty any consumable parts, including batteries, fuses, buttons, relays, and transmitter and receiver cases.
- This warranty does not include damage caused by improper installation (including ignoring environmental specifications), improper or insufficient maintenance, any modifications, improper operation, or improper software interfacing.
- The remedies provided herein are the buyer's sole and exclusive remedies. ITL shall not be liable for any direct, indirect, special, incidental or consequential damages.

## 1.5 Warranty Contact Information



Please contact us at the address below for further help or if you have any questions:

Intercontinental Technologies  
558-2 Plate Drive  
East Dundee, IL 60118 USA  
Phone: 847-426-9597  
Fax: 847-426-9724

Or Call Us Toll Free at (800) 382-3558



## Chapter 2 Safe Operation

### ***Emergency Procedure***

***In case of emergency, perform these steps IN ORDER:***

1. Press the Red STOP Button.
2. Turn the Green Rotary Key Switch to the OFF position and remove the key from the transmitter.
3. Switch off the main power to the crane.
4. Contact your distributor or installer.



**NOTE: Read ALL safety information before you operate this product.**

### **2.1 Emergency Procedures**

If the F22 unit detects an error or system fault, it will issue an emergency STOP command and deactivate all systems programmed for a STOP command. It is therefore important to install the F22 system correctly so that if it detects a fault, it can perform an emergency stop and the crane will shut down safely.

### **2.2 General Safety Information**

**This manual is intended for the user as a general reference only. Please consult your distributor for installation or assistance with specific technical issues.** In an industrial environment, safety must always be a top priority. Persons responsible for installation, operation, and maintenance must make certain that both their actions and the equipment on which they work are safe. This chapter includes a list of safety rules that must be followed when working with TELECRANE products, as well as cranes in general. This list is not intended to be all-inclusive. General industrial safety rules must always be followed. If there is any doubt about how to proceed, always take the safest course of action.

### **2.3 Installation Safety**

Only qualified personnel should install this product. For installation instructions and safety information, refer to Part 2 of this manual.

### **2.4 Operational Safety**

- Operating any piece of equipment in an industrial facility can be dangerous; therefore, provide adequate training to operators of cranes that use this equipment.
- At least once each shift, check the amount of power remaining in the transmitter batteries (see Section 4.1.3, “Checking Battery Power”). If it is low, change all four batteries before beginning operation. Operating the unit with excessively discharged batteries can be unsafe.

- If the transmitter battery power becomes insufficient, the transmitter will send out an Emergency Stop signal (EMS). This signal will stop all actions previously set to shut down when a STOP signal is received. The LED on the transmitter will illuminate red continuously and the buzzer on the transmitter will buzz continuously until the batteries are removed. If this occurs, replace all four batteries before using the product again.
- The magnetic safety key should be removed from the transmitter whenever it is not in use and should only be issued to authorized personnel.
- All TELECRANE F22 Radio Remote Controls are tested before they leave the factory. However, they should not be used in dangerous situations or in a manner such that damage might result.
- Although the transmitter is very durable and weather-resistant, precautions should always be taken to limit its exposure to weather, physical impact, and corrosives.
- After use, or if the unit will not be used for a long interval, turn off the power to the crane and remove the magnetic safety key from the transmitter.
- Remove the batteries from the transmitter if the transmitter will not be used for two weeks or longer.
- Transmitters that are not in use, including spare transmitters, should be secured to prevent accidental operation.
- Before each shift, check that the limit switches on the crane function correctly.
- Before each shift, check that the movement of the crane corresponds to the button being pressed on the transmitter.
- Do not use the product during lightning storms or high electrical interference conditions.

## **2.5 Safety When Performing User Maintenance**

Before performing any maintenance on this product, review Chapter 5, “User Maintenance.”

## Chapter 3 Overview of Parts and Features

This Chapter describes the major parts and features of the F22 Series Industrial Radio Remote Controller.

F22 Series radio remote controls are available in different styles to meet different needs. The two basic configurations are *handheld* and *joystick*.

Handheld controllers are available in two configurations: “Mini-Style” and “N1-Style.” The Mini-Style handhelds are new, advanced designs that are sleek and compact. They are easily held and operated using one hand. The Mini-Style is available in two different chassis sizes: Large and Small. Mini-Style transmitters are pictured in Sections 3.1 and 3.2.

N1-Style transmitters are designed for more severe service and include a heavy-duty chassis. They are recognizable by their larger round buttons. N1-Style model numbers end in “1.” An N1-Style transmitter is pictured in Section 3.3.

Both handheld models are available in different sizes and configurations, and can be customized to a specific application. Both styles of transmitters utilize a similar receiver, pictured in Section 3.4.

The Joystick controller provides advanced functions and extended customization in a compact, two-joystick configuration. The Joystick transmitter and receiver are pictured in Sections 3.5 and 3.6.

### 3.1 Large Chassis Mini-Style Transmitter

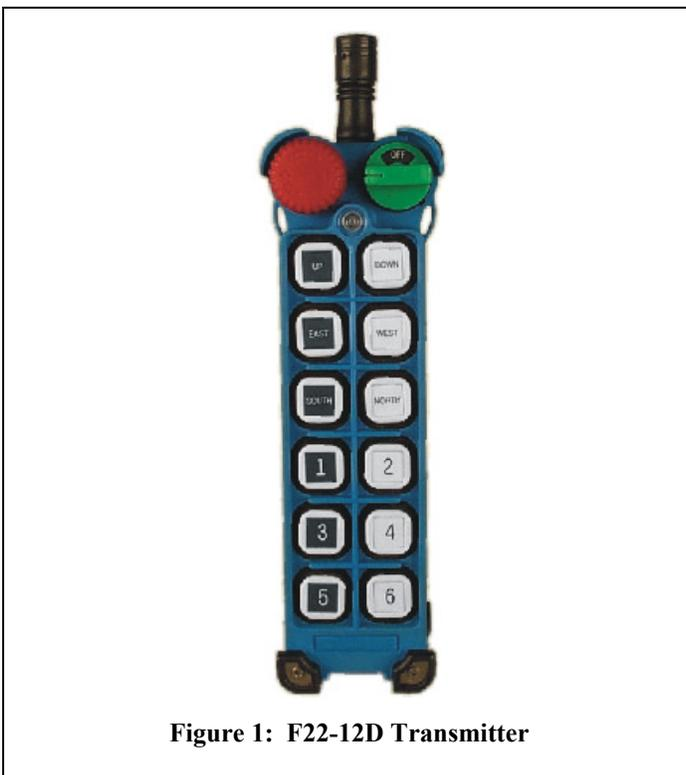

Figure 1: F22-12D Transmitter

The following models are available in the large chassis Mini-Style:

- F22-12D
- F22-12S

Figure 1 is a picture of the F22-12D, a Large Chassis Mini-Style transmitter.

### 3.2 Small Chassis Mini-Style Transmitter



The following models are available in the small chassis Mini-Style:

- **F22-2S**
- **F22-2D**
- **F22-4S**
- **F22-4D**
- **F22-6S**
- **F22-6D**

Figure 2 is a picture of the F22-6D, a Small Chassis Mini-Style transmitter.

### 3.3 N1-Style Transmitter

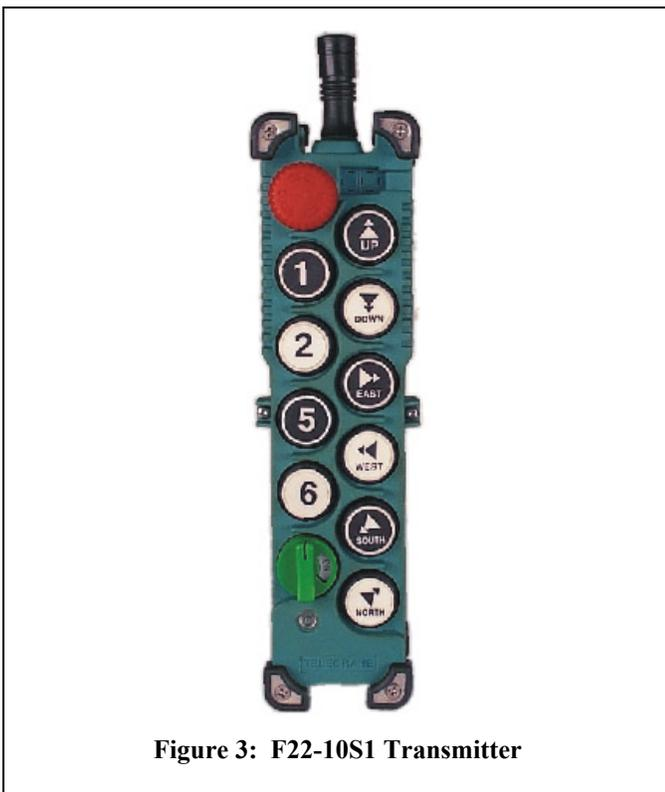

The following models are available in the N1-Style:

- **F22-2S1**
- **F22-2D1**
- **F22-4S1**
- **F22-4D1**
- **F22-6S1**
- **F22-6D1**
- **F22-10S1**
- **F22-10D1**

Figure 3 is a picture of the F22-10S1, an N1-Style transmitter.

### 3.4 Typical Receiver for Handheld Models

Figure 4 below shows the front and back of a typical receiver for handheld models.



Figure 4: Typical Receiver for Handheld Models (front and back)

### 3.5 Transmitter for the Model F22-J Joystick Controller

Figure 5 below shows the top and bottom of the F22-J joystick transmitter.



Figure 5: F22-J Joystick Transmitter (top and bottom)

### 3.6 Receiver for the Model F22-J Joystick Controller

Figure 6: Receiver for the F22-J joystick controller.



Figure 6: F22-J Receiver (front and back)

**THIS PAGE INTENTIONALLY LEFT BLANK**



## Chapter 4    Operation of the F22 Series Industrial Radio Remote Controller

**⚠ Note: Operating industrial equipment can be hazardous. Use TELECRANE equipment only in accordance with the directions specified in this manual and follow all safety guidelines. Only trained personnel should use TELECRANE equipment.**

### 4.1 Normal Operation of the Handheld and Joystick Models

The F22 Series Industrial Radio Remote Controls offer flexibility for a variety of applications and functions that can be specified and set at the factory. The system consists of a receiver and two transmitters, and uses a series of pushbuttons and other controls to operate a crane or industrial equipment. This chapter describes the general operation of the TELECRANE system, and provides specific information related to both the handheld and joystick models.

#### 4.1.1 Pre-Operational Checks

Before you operate this product, perform the following checks to ensure that the unit is in proper working order:

Periodically inspect the limit switches on the crane and ensure that they actuate correctly and stop the motion they control.

Inspect the position and location of the equipment to ensure that the transmitter and receiver are not exposed to a damaging environment such as high temperatures or high impact.

#### 4.1.2 Power-On Procedure

**⚠ Inspect the transmitter and receiver at the start of each work day to ensure safe operation of this product.**

Note: If the password feature has been enabled, follow the Power-On procedure described in Section 4.2.1. (Password feature available only on handheld models).

To turn on the transmitter:

1. Retrieve the green Rotary Key and place it in the transmitter.
2. Disable the Emergency Stop by turning the red EMS button clockwise until it pops out, then releasing.
3. Turn the green Rotary Key Switch clockwise past “ON” to the “START” position, note the LED color, then release. The switch will spring back to the ON position and a tone will sound. The transmitter is now active.



At the start of each shift, perform the following safety checks:

1. Confirm that there is sufficient battery power to operate the transmitter: If the LED color during the power-on procedure was green, then there is sufficient battery power to operate the transmitter. If the LED color was yellow or red, then battery power is low and all four batteries should be replaced immediately. See Table 4-1-3 below for more details.
2. Test the emergency stop function by pressing the red EMS button (shown in Figure 7). A tone will sound and the LED will flash red and green alternately to indicate actuation of the emergency stop. If this does not occur, do not

use the transmitter. If the emergency stop function works correctly, then restart the transmitter.

3. Confirm that the movement of the crane or other equipment corresponds to the appropriate control being activated on the transmitter.

#### 4.1.3 Checking Battery Power

The transmitter will not work properly unless sufficient battery power is available. Before each use, check the battery power and, if needed, replace the batteries following the battery changing procedure in Section 5.3 (handheld models) or 5.4 (joystick model).

Remaining battery power is indicated by the color of the transmitter’s LED display (the circular light adjacent to the green Rotary Key Switch). When the unit is turned on and whenever any button is pressed, the LED will turn green, yellow, or red to indicate the remaining power.

**To avoid motion of the crane or other equipment, use the Rotary Key Switch during a manual battery check.** To do this, turn the green Rotary Key Switch clockwise past “ON” to the “START” position and hold it there. The LED will indicate the remaining power according to Table 4-1-3 below (Note: Ensure that the R0 Relay is not connected to any device because this step will activate that relay):

Table 4-1-3 Battery Power Indicator

LED Color	Battery Power Level
Green	Sufficient power to operate.
Yellow	Battery power is too low. Change the batteries as soon as it is safe to do so. A warning beep will sound every 4 seconds when any button is depressed. Follow the battery changing procedure in Chapter 1, Section 5.3 (handheld models) or 5.4 (joystick model).
Red	There is insufficient power to operate normally and the transmitter will send an emergency stop signal to the receiver. Follow the battery changing procedure in Chapter 1, Section 5.3 (handheld models) or 5.4 (joystick model).

#### 4.1.4 Pushbutton Operation

The F22 Series transmitters can control a large number of motions and include factory programming customized to your application. As a result, the specific function of each button will vary depending on the application. See Chapter 10 of this manual for descriptions of the standard and custom button functions that are available.

Operate the transmitter by pressing the appropriate motion and auxiliary buttons for your application. Depending on which model you select, some or all of the following types of pushbuttons are available:

Table 4-1-4. Pushbutton Types and Descriptions

Pushbutton Type	Description
<b>Normal (Non-Interlocked)</b>	<i>Non-interlocked</i> pushbuttons are standard ON/OFF pushbuttons. The relay is ON when the pushbutton is pressed and held, and OFF when the pushbutton is released. A typical application for a <i>non-interlocked</i> button would be a horn.
<b>Normal (Interlocked)</b>	<i>Interlocked</i> pushbuttons are pairs of buttons programmed to prevent simultaneous operation of certain relays. A typical example of <i>interlocked</i> pushbuttons would be to prevent simultaneous operation of relays that actuate EAST and WEST motions of a trolley. If two <i>interlocked</i> pushbuttons are pressed at the same time, then both relays are switched OFF.
<b>Toggle</b>	The relay is switched ON when the button is pressed once and released. The relay is switched OFF when the same button is pressed again and released. A typical application for a <i>toggle</i> button would be lights.
<b>On-Off</b>	A set of two buttons where one latches the relay ON and the other latches the relay OFF. A typical application for <i>on-off</i> buttons would be a magnet.
<b>2-Step</b>	A <i>2-step</i> button has two ON positions: Half- and fully-depressed. A typical application for a <i>2-step</i> button is to control a 2-speed motion; the half-depressed position could correspond to a slow speed and the fully-depressed position could correspond to a faster speed. They can also control variable speed drives as well, such as “infinitely variable” type applications.

#### 4.1.5 Power-Down Procedures

To turn off the transmitter:

1. Press the red Emergency Stop (EMS) button.
2. Rotate the green Rotary Key Switch counterclockwise to the OFF position.
3. Remove the key and store it in a secure place.
4. If the transmitter will not be used for two weeks or longer, then remove the batteries and store them in a cool, dry place.

## 4.2 Special Functions of Handheld Models

### 4.2.1 Entering a Password (Optional)

The F22 Series Handheld models provide the ability to require a four-character password before use. This feature helps prevent unauthorized or inadvertent use of industrial equipment. *This feature must be enabled, and the password set, at the factory.*

If this option has been enabled, then the operator will be required to enter a four-character password before operating the transmitter. To enter a password, follow the steps below during normal power-on (Note: Do not follow the steps listed in Section 4.1.2):

1. Rotate the red EMS Button clockwise 45° and pull out.
2. Turn the green Rotary Key Switch clockwise to the ON position (Note: Do not turn the switch all the way to START).
3. While the LED is flashing green, press the pushbuttons sequentially to enter the four-character password (Note: There is a 10-second time limit).
4. If the password was entered correctly, then the buzzer will sound one long tone.
5. After the buzzer stops, turn the Rotary Key Switch to the START position and release. It will spring back to the ON position. The transmitter is now ready for normal use.
6. If the password was entered incorrectly, then the buzzer will sound two short and one long tone.
7. After the buzzer stops, re-enter the correct password.

Table 4-2-1. Signals for Correct / Incorrect Password

<b>Correct Password</b>	<b>Transmitter Sounds 1 Long Tone, LED Lights Green</b>
<b>Incorrect Password</b>	<b>Transmitter Sounds 2 Short and 1 Long Tone. Try again.</b>

**Note:** The password must be re-entered to return to normal operation if either:

1. The EMS Button is pressed; OR
2. An emergency stop signal is sent to the receiver due to a (factory-settable) period of inactivity (see Sections 10.4 and 10.5 for a description of the Auto-Shutdown feature).

### 4.2.2 Ratcheting Operation

Ratcheting is the ability to increase or decrease speed in discrete steps. This function is available on handheld models F22-10D1, F22-12D, F22-6D and F22-6D1. The “ratchet up” button is **5** on F22-10D1 and F22-12D, and **South** on F22-6D and F22-6D1. The “ratchet down” button is **6** on F22-10D1 and F22-12D, and **North** on F22-6D and F22-6D1. To use ratcheting:

1. Press and hold the button controlling the desired motion, then press the “**ratchet up**” pushbutton to incrementally increase the speed of the equipment, or the “**ratchet down**” pushbutton to incrementally decrease the speed of the equipment.
2. When a motion button is fully depressed, one touch of the “**ratchet up**” button will move to the next highest speed. Repeated touches will increase the speed up to four more times (six total speeds, including the initial 2-step button press).

- To reduce the speed, press the “**ratchet down**” button once. Repeated pressing will reduce the speed to the lowest speed of the ratcheting feature. To get to the lowest speed, lift the motion button from the second step to the first step.

**Note:** When accelerating or decelerating with the ratchet function, the motion button must be fully depressed. If the motion button is fully released, then the speed will return to zero. If a two-step motion button is partially released, then the speed will return to the lowest setting.

Table 4-2-2 Pushbuttons for Ratcheting

Any Motion Button/Second Speed + Pushbutton <b>5 or South</b>	Increase Speed
Any Motion Button/Second Speed + Pushbutton <b>6 or North</b>	Decrease Speed

### 4.2.3 Inching Operation

*Inching* is the ability to move a load in small increments so that it can be more precisely controlled, without requiring the user to press and release buttons very rapidly. This function is available on all handheld models with pushbutton **5**. To use the inching function:

- Ensure that all pushbuttons are released and that the equipment is motionless.
- Press and hold the **5** pushbutton.
- Press the applicable motion pushbutton to move the load a small distance in that direction.

## 4.3 Special Functions of Joystick Models

The Model F22-J Joystick Type Remote Controller offers broad flexibility on a variety of applications through user-specific, customizable functions that are pre-programmed at the factory. The system includes a transmitter and a spare transmitter, each with two joysticks, six pushbuttons, and four rotary dials. The F22-J controller transmitter offers the most flexibility for a wide range of applications.

### 4.3.1 Buttons on the Joystick Controller

The Joystick controller includes pushbuttons similar to those on the F22 Series Handheld units. The pushbuttons can control motion or auxiliary functions and are custom-programmed at the factory for your specific application. See Chapter 10 for detailed descriptions of the functions that are available, and Section 10.2 for a discussion of button types.

### 4.3.2 Joystick Operation: Direction of Movement

The F22-J includes two joysticks, each of which can control four primary directions of motion. The directions of motion can be combined so that, for example, a bridge/trolley combination can move North and East simultaneously. The functions for axial movements of Joystick 1 and Joystick 2 are preset at the factory based on your application. A typical setting might be:

Joystick 1 (Controls Bridge and Trolley)		Joystick 2 (Controls Hoists)	
Direction	Motion	Direction	Motion
Forward	Bridge moves North	Forward	Hoist moves UP
Back	Bridge moves South	Back	Hoist moves DOWN
Left	Trolley moves West	Left	Aux Hoist moves DOWN
Right	Trolley moves East	Right	Aux Hoist moves UP

### 4.3.3 Joystick Operation: Speed Settings

In each of the four directions of motion, the joysticks can have up to five detent positions. For example, there could be five detents in the forward direction, each of which could be associated to a speed setting. A smaller number of detent positions can also be specified and set at the factory.

The time elapsed between a change from one speed to the next can be customized for your particular application.

### 4.3.4 Joystick Operation: Rotary Switch Operation

The F22-J joystick type transmitter is supplied with four rotary switches labeled A, B, C, and D. Rotary switches A and D are simple ON/OFF switches designed to control items like magnets and lights.

The B and C switches are three-position switches normally used to switch between different systems. For example, rotary switch B could control Hoist 1, Hoist 2, or both Hoist 1 and Hoist 2 simultaneously.

The table below summarizes the available switches and switch positions:

	Switch A	Switch B*	Switch C*	Switch D
Available Positions	On Off	A (A+B) or Neither B	A (A+B) or Neither B	On Off

\*Three-position switch

Note that the names of Switches A and B are not related in any way to the names of Positions A and B.

## Chapter 5 User Maintenance

### 5.1 Safety Aspects of User Maintenance

- In general, maintenance on this product should only be performed by your installer, distributor, or ITL.
- Ensure that anyone performing maintenance on the unit is thoroughly familiar with its operation.
- The crane's power sources should be shut off before any maintenance begins, unless absolutely required for troubleshooting the unit. When the power to the crane is on, use extreme caution. High voltage or unexpected movement of the crane can cause death or severe injury.
- Fall prevention devices should be used when anyone is working on the crane at an elevated height.
- Only ITL-certified maintenance personnel should attempt a repair more involved than the swapping of printed circuit boards. Improper repair can compromise the built-in safety features and can cause unexpected operation and damage.
- This product uses four AA alkaline batteries. When replacing batteries, all four must be replaced at the same time.
- ITL does not recommend use of nickel-cadmium batteries due to voltage characteristics that cause a sudden loss of power when discharged. They also have less capacity than AA alkaline batteries.

### 5.2 Unusual Alarms

The F22 Series Industrial Radio Remote Controller is equipped with a self-diagnostic program. If a malfunction is detected during the operation of the equipment, the system will sound an *alarm* on the receiver to indicate a receiver malfunction, or a *buzzer* on the transmitter to indicate a transmitter malfunction. If this occurs, review Chapter 6 of the Operator's Manual, "Basic Troubleshooting."

### 5.3 Battery Changing Procedure (Handheld Models)

1. Unscrew the cover of the battery compartment.
2. Remove and discard the old batteries.
3. Install 4 new AA alkaline batteries into the battery compartment, noting the polarity markings.
4. Replace the cover of the battery compartment.
5. Confirm proper installation: If the batteries were installed correctly, the transmitter will beep twice. If the transmitter does not beep twice, check battery polarity.

### 5.4 Battery Changing Procedure (Joystick Models)

1. Unscrew and open the hinged battery cover.
2. Remove the battery caddy and discard the old batteries.
3. Install 4 new AA alkaline batteries into the battery caddy noting the polarity markings.
4. Replace the battery caddy and close the hinged battery cover.
5. Confirm proper installation: If the batteries were installed correctly, the transmitter will beep twice. If the transmitter does not beep twice, check battery polarity.

**THIS PAGE INTENTIONALLY LEFT BLANK**



## Chapter 6 Basic Troubleshooting

### 6.1 Reliability

The F22 Series of remote controllers are designed for high reliability in an industrial environment. Design features include:

- Heavy duty, shock-resistant design
- Constructed from corrosion-resistant materials
- Button life in excess of 2,000,000 cycles
- Self-diagnostics to simplify troubleshooting and maintenance

In addition to these features, all handheld and joystick models are delivered with two complete transmitters. This provides the ultimate in reliability; in the event that one transmitter is damaged, you can switch to the backup transmitter.

### 6.2 Self-Diagnostics and Error Codes

Both the transmitter and receiver of the F22 Series are designed with sophisticated self-diagnostics to simplify troubleshooting and maintenance. This allows for detection of malfunctions in the pushbuttons, joystick, RF circuit, and relay driver circuits. The system will sound an alarm signal in Morse Code if a malfunction occurs in either the transmitter or receiver (see Chapter 11 for a table of error codes).

If an error message is detected by the self-diagnostic program, then the appropriate alarm signal will sound and a Power-Off of the system will be initiated. Until the malfunction is corrected, the system will remain shut down (see Section 7.1 for more information).

### 6.3 User Troubleshooting

In the event that a problem occurs, follow the listed steps in order until the unit is functioning normally. If you are unable to solve the problem, then return the unit to your distributor for service.

1. Check the EMS switch. If it is depressed, reset it by rotating clockwise until it pops up.
2. Check the green Rotary Start Switch. If it is missing, replace it. If it is present, turn it to OFF. Then turn it clockwise past "ON" to the "START" position, then release. The switch will spring back to the ON position and a tone should sound.
3. Ensure that the batteries are present and charged (see Section 4.1.3) and replace if necessary.
4. Turn off the transmitter and try using the backup transmitter. (Note: Before using the backup transmitter, check its battery power (see Section 4.1.3) and replace batteries if necessary). If use of the backup transmitter solves the problem, return the malfunctioning transmitter to your distributor for service. If the backup transmitter does not work, then the problem may be with the receiver.

If the transmitter is damaged or malfunctioning, then return it to your distributor for service and use the backup transmitter in the meantime.

If the receiver appears to be damaged or malfunctioning, then ensure that the green carrier light illuminates when a button on a working transmitter is pressed. This light is one of the LED's on the front cover of the receiver. If the carrier light does not illuminate, contact your distributor.

Both the transmitter and receiver are equipped with self-diagnostics. If either one detects a malfunction, it will sound an error message in Morse code. If this occurs, record the error message (a series of long and short tones) and inform your distributor.

## Part 2: Technician's Manual

### Chapter 7 Safe Installation

#### ***Emergency Procedure***

***In case of emergency, perform these steps IN ORDER:***

1. Press the Red STOP Button.
2. Turn the Green Rotary Key Switch to the OFF position and remove the key from the transmitter.
3. Switch off the main power to the crane.
4. Contact your distributor or installer.



**NOTE: Read ALL safety information before you install or operate this product.**

#### **7.1 Emergency Procedures**

If the F22 unit detects an error or system fault, it will issue an emergency STOP command and deactivate all systems programmed for a STOP command. It is therefore important to install the F22 system correctly so that if it detects a fault, it can perform an emergency stop and the crane will shut down safely.

#### **7.2 General Safety Information**

In an industrial environment, safety must always be a top priority. Persons responsible for installation, operation, and maintenance must make certain that both their actions and the equipment on which they work are safe. This chapter includes a list of safety rules that must be followed when working with TELECRANE products, as well as cranes in general. This list is not intended to be all-inclusive. General industrial safety rules must always be followed. If there is any doubt about how to proceed, always take the safest course of action.

#### **7.3 Installation Safety**

- Before installing or operating this product, read this manual thoroughly. If you have any questions, please contact ITL.
- Only qualified personnel who are familiar with the product and who have read these safety instructions should install TELECRANE products.
- All sources of power to the crane or controlled equipment must be de-energized and applicable lockout/tag out procedures executed before installing the unit.
- Before installing the receiver, energize it in a controlled environment (for example, an office) where it can be tested and set up properly before it is mounted in the field.

- Before installation, be certain to understand the electrical functioning of the crane, including the order and relationship of motions and contactors.
- Fall prevention devices should be used when anyone is working on the crane.
- The receiver must be securely attached and located where it will not be hit by any moving part of the building, crane, or load.
- The crane must be equipped with limit switches for each motion and a main power contactor that cuts off all power to the motors of the crane when it is de-energized.
- Special care must be taken for magnets and other load-carrying devices; ensure that if the crane is de-energized the load remains supported.
- The receiver must be located so that it receives sufficient signal strength from the transmitter. The preferred location is in sight of the operator. However, if this is not possible (e.g., if the receiver unit is in a metal box), then an external antenna should be mounted such that it is in sight of the operator.
- Test the unit before placing it in service. If the crane does not work exactly as intended, fix the problem and test it again.

## Chapter 8 Installation

### 8.1 Transmitter Installation

No special installation is required for F22 Series Industrial Radio Remote Controller transmitters. However, before the unit can be operated, check the battery power (see Section 4.1.3). If fresh batteries are required, install them as described below:

#### 8.1.1 Battery Installation (Handheld Models Only)

1. Unscrew the cover of the battery compartment.
2. If present, remove and discard the old batteries.
3. Install 4 new AA alkaline batteries into the battery compartment, noting the polarity markings.
4. Replace the cover of the battery compartment.
5. Confirm proper installation: If the batteries were installed correctly, the transmitter will beep twice. If the transmitter does not beep twice, check battery polarity.

#### 8.1.2 Battery Installation (Joystick Models Only)

1. Unscrew and open the hinged battery cover.
2. If present, remove the battery caddy and discard the old batteries.
3. Install 4 new AA alkaline batteries into the battery caddy noting the polarity markings.
4. Replace the battery caddy and close the hinged battery cover.
5. Confirm proper installation: If the batteries were installed correctly, the transmitter will beep twice. If the transmitter does not beep twice, check battery polarity.

### 8.2 Receiver Installation



#### ***Precautions During Receiver Installation***

1. Observe all safety precautions and use fall protection devices when climbing the crane.
2. Turn off the main power source to the crane before installation to prevent electrical shock.
3. Securely fasten the receiver to the crane and ensure that it is located such that it does not touch any part of the building during operation.
4. Inspect the crane's limit switches and other applicable safety devices before installation to ensure that they are in proper working condition.
5. Understand the crane power and control circuits and the function settings of the remote controller before installation.
6. Locate the receiver away from motors, frequency converters, and power cables to avoid radio interference.
7. Use an extended antenna if the receiver is installed in a metal enclosure.

#### 8.2.1 Preparing for Receiver Installation

1. Select a proper location.
  - Select a stable place.

- If possible, select a place where you can see the receiver or antenna during operation.
  - Select a place away from motors, relays, high-voltage wiring, magnetic switches, and power cables.
  - The receiver must be at least 3 cm away from any obstacles.
2. Determine the available power source. The standard input voltage for the handheld's receiver is 120 VAC, 60 Hz (240 VAC and 12 or 24 V, AC or DC, are also available). The joystick's receiver auto-detects the power source and can accept either 120 VAC, 60 Hz or 240 VAC, 60 Hz, with no action required by the installer.

### 8.2.2 Mounting and Connecting the Receiver

To mount and connect the receiver, perform the following steps:

1. Turn off the main power of the crane.
2. Drill the holes for the mounting screws, install the receiver, and then mount the receiver using 6mm nuts on the vibration-resistant rubber stand-offs. Refer to the Technical Sheet for the receiver for the size and location of the mounting holes.
3. Connect the wires from the cable to the control circuit of the crane. Refer to the Technical Sheets in Chapter 14 for a schematic diagram of the receiver (or see the schematic on the front of the receiver itself). Note that the numbers in parentheses on the schematic correspond to the wire number in the cable.
4. Secure the cables to avoid wear due to the vibration of the crane or other factors.
5. Twist and pull out the red Stop button on the receiver.

### 8.2.3 Receiver Installation Test Plan

The Run/Test toggle switch inside the receiver is provided to enable testing of the unit before it is placed in service. When the switch is in the RUN position, the unit functions normally. When the switch is in the TEST position, relay power is interrupted; the LEDs will light but the relays will not actuate.

To test the unit:

1. Open the top cover of the receiver and set the Run/Test switch to the TEST position (see Section 12.2.5).
2. Turn on the main power for crane.
3. Using the transmitter, test each button and function; the relays will not actuate but the LEDs will illuminate.
4. After testing, set the Run/Test switch to the RUN position and replace the top cover of the receiver.

## 8.3 Installation of Optional Accessories

For installation of any optional accessories such as the Extended Antenna Kit, refer to the accessory's Technical Sheet in Chapter 14.

## **Chapter 9     Programming By Computer**

### **9.1   Overview**

The Telecrane F22 Series Radio Remote Controls use a Windows based application program to read, write, and change their programming. This programming is generally performed at the factory when a unit is ordered, and is selected by the customer from the options in Chapter 10 and communicated by means of the “Programming Sheets” in Chapter 14. In some specific cases, for example, when a large distributor wishes to stock a number of units, for which the programming requirements are not known when the units are ordered from ITL, this programming must be accomplished outside the factory. ITL can provide to such a distributor a laptop computer, preloaded with the application program and other required programs. Instructions for use of the computer and program are provided with the unit.

**THIS PAGE INTENTIONALLY LEFT BLANK**



## Chapter 10 Function Settings

Industrial Radio Remote Controllers are used in diverse operating environments and have a wide range of applications and uses. This creates a need for flexibility and control over the setting of the functions designed into these controllers. Default parameters are set at the factory, but many functions and parameters can be customized to provide particular operating functions.

This Chapter provides a detailed list of the available functions of the F22 Series and the range of settings for each. The Technical Sheets in Chapter 14 also include a summary list of parameters and settings that can be customized to meet your specific needs.

Please note that the F22 Series includes many customizable functions that are set at the factory and not usually changed. To avoid confusion, only those functions that are typically specified by the user are listed here. However, if you have a need for a function setting that is not listed, please contact ITL to determine if that function is available.

### 10.1 Description

Many of the functions of the F22 Series are set at the factory to meet most user's requirements, and, in most cases, no change is required. However, if you have a need that requires changes from the default setting, your unit can be specially programmed at the factory. The tables below list the transmitter and receiver functions, default settings, and custom settings available on the F22 Series Handheld and F22-J Joystick Model Industrial Radio Remote Controllers. Please contact ITL or your local distributor for more information regarding alternate function settings, or refer to the Technical Sheets in Chapter 14 of this Manual.

### 10.2 F22 Series Handheld Transmitter Function Settings

The table below shows the functions available on the handheld F22 Series models, their available settings, and their default settings. Note: This table lists all functions for the F22 Handheld models depending on which buttons are available on each specific model number. Refer to the Technical Sheets in Chapter 14 for a list of functions available by model.

Table 10.2: Handheld Transmitter Functions and Default Settings

Function/Setting	Description /Notes	Available Settings	Default Setting
<b>Enable Password</b>	Enable or disable the Password Function	<ul style="list-style-type: none"> <li>• Enabled</li> <li>• Disabled</li> </ul>	Disabled
<b>Password</b>	Password to be entered by user before operation	<ul style="list-style-type: none"> <li>• 4 character password</li> </ul>	N/A
<b>UP Button</b>	Control button	<ul style="list-style-type: none"> <li>• Normal, interlocked</li> <li>• Normal, not interlocked</li> <li>• Toggle (on/off)</li> <li>• On (off is button DOWN)</li> </ul>	Normal, interlocked with button DOWN

<b>Function/Setting</b>	<b>Description /Notes</b>	<b>Available Settings</b>	<b>Default Setting</b>
<b>DOWN Button</b>	Control button	<ul style="list-style-type: none"> <li>• Normal, interlocked</li> <li>• Normal, not interlocked</li> <li>• Toggle (on/off)</li> <li>• Off (on is button UP)</li> </ul>	Normal, interlocked with button UP
<b>EAST Button</b>	Control button	<ul style="list-style-type: none"> <li>• Normal, interlocked</li> <li>• Normal, not interlocked</li> <li>• Toggle (on/off)</li> <li>• On (off is button WEST)</li> </ul>	Normal, interlocked with button WEST
<b>WEST Button</b>	Control button	<ul style="list-style-type: none"> <li>• Normal, interlocked</li> <li>• Normal, not interlocked</li> <li>• Toggle (on/off)</li> <li>• Off (on is button EAST)</li> </ul>	Normal, interlocked with button EAST
<b>SOUTH Button</b>	Control button	<ul style="list-style-type: none"> <li>• Normal, interlocked</li> <li>• Normal, not interlocked</li> <li>• Toggle (on/off)</li> <li>• On (off is button NORTH)</li> </ul>	Normal, interlocked with button NORTH
<b>NORTH Button</b>	Control button	<ul style="list-style-type: none"> <li>• Normal, interlocked</li> <li>• Normal, not interlocked</li> <li>• Toggle (on/off)</li> <li>• Off (on is button SOUTH)</li> </ul>	Normal, interlocked with button SOUTH
<b>1 Button</b>	Control button	<ul style="list-style-type: none"> <li>• Normal, not interlocked</li> <li>• Normal, interlocked with button 2</li> <li>• Toggle (on/off)</li> <li>• On (off is button 2)</li> </ul>	Normal, not interlocked

Function/Setting	Description /Notes	Available Settings	Default Setting
<b>2 Button</b>	Control button	<ul style="list-style-type: none"> <li>• Normal, not interlocked</li> <li>• Normal, interlocked with button 1</li> <li>• Toggle (on/off)</li> <li>• Off (on is button 1)</li> </ul>	Normal, not interlocked
<b>3 Button</b>	Control button	<ul style="list-style-type: none"> <li>• Normal, not interlocked</li> <li>• Normal, interlocked with button 4</li> <li>• Toggle (on/off)</li> <li>• On (off is button 4)</li> </ul>	Normal, not interlocked
<b>4 Button</b>	Control button	<ul style="list-style-type: none"> <li>• Normal, not interlocked</li> <li>• Normal, interlocked with button 3</li> <li>• Toggle (on/off)</li> <li>• Off (on is button 3)</li> </ul>	Normal, not interlocked
<b>5 Button</b>	Control button	<ul style="list-style-type: none"> <li>• Normal, not interlocked</li> <li>• Toggle (on/off)</li> <li>• Ratchet up</li> <li>• Inching: <ul style="list-style-type: none"> <li>○ 0.1 seconds</li> <li>○ 0.2 seconds</li> <li>○ 0.3 seconds</li> <li>○ 0.4 seconds</li> <li>○ 0.5 seconds</li> </ul> </li> </ul>	<ul style="list-style-type: none"> <li>• Normal, not interlocked</li> <li>• No inching</li> </ul>
<b>6 Button</b>	Control button	<ul style="list-style-type: none"> <li>• Normal, not interlocked</li> <li>• Toggle (on/off)</li> <li>• Ratchet down</li> </ul>	Normal, not interlocked

### 10.3 F22 Series Joystick Transmitter Function Settings

The table below shows the functions available on the F22-J (Joystick) model, the available settings, and the default settings.

Table 10.3 Joystick Transmitter Functions and Default Settings

Function/Setting	Description /Notes	Available Settings	Default Setting
<b>1 Button</b>	Control button	<ul style="list-style-type: none"> <li>• Normal, not interlocked</li> <li>• Normal, interlocked with button 2</li> <li>• Toggle (on/off)</li> <li>• On (off is button 2)</li> <li>• Specific, for dual motor systems</li> </ul>	Normal, interlocked with button 2
<b>2 Button</b>	Control button	<ul style="list-style-type: none"> <li>• Normal, not interlocked</li> <li>• Normal, interlocked with button 1</li> <li>• Toggle (on/off)</li> <li>• Off (on is button 1)</li> <li>• Specific, for dual motor systems</li> </ul>	Normal, interlocked with button 1
<b>3 Button</b>	Control button	<ul style="list-style-type: none"> <li>• Normal, not interlocked</li> <li>• Normal, interlocked with button 4</li> <li>• Toggle (on/off)</li> <li>• On (off is button 4)</li> </ul>	Normal, interlocked with button 4
<b>4 Button</b>	Control button	<ul style="list-style-type: none"> <li>• Normal, not interlocked</li> <li>• Normal, interlocked with button 3</li> <li>• Toggle (on/off)</li> <li>• Off (on is button 3)</li> </ul>	Normal, interlocked with button 3
<b>5 Button</b>	Control button	<ul style="list-style-type: none"> <li>• Normal, not interlocked</li> <li>• Normal, interlocked with button 6</li> <li>• Toggle (on/off)</li> <li>• On (off is button 6)</li> </ul>	Normal, interlocked with button 6

Function/Setting	Description /Notes	Available Settings	Default Setting
<b>6 Button</b>	Control button	<ul style="list-style-type: none"> <li>• Normal, not interlocked</li> <li>• Normal, interlocked with button 5</li> <li>• Toggle (on/off)</li> <li>• Off (on is button 5)</li> </ul>	Normal, interlocked with button 5
<b>A Dial</b>	Control Dial	On/off	On/off
<b>B Dial</b>	Control Dial	<ul style="list-style-type: none"> <li>• A, A+B, B</li> <li>• A, Off, B</li> </ul>	A, A+B, B
<b>C Dial</b>	Control Dial	<ul style="list-style-type: none"> <li>• A, A+B, B</li> <li>• A, Off, B</li> </ul>	A, A+B, B
<b>D Dial</b>	Control Dial	On/off	On/off
<b>Joystick 1</b>	2-axis (X and Y) joystick controller	<ul style="list-style-type: none"> <li>• 4 directions, 5 or fewer detents* in each direction, interlocking</li> <li>• Extensive custom programming available, see Technical Sheet in Chapter 14</li> </ul>	4 directions, 5 detents in each direction
<b>Joystick 2</b>	2-axis (X and Y) joystick controller	<ul style="list-style-type: none"> <li>• 4 directions, 5 or fewer detents* in each direction, interlocking</li> <li>• Extensive custom programming available, see Technical Sheet in Chapter 14</li> </ul>	4 directions, 5 detents in each direction

\*Refer to Chapter 14 for additional detent settings

## 10.4 F22 Handheld Series Receiver Function Settings

The table below shows the functions available on the F22 Handheld Series receivers, their available settings, and their default settings. Note: This table lists all functions for the F22 Series receivers; certain models may not have all listed functions.

Table 10.4 Handheld Receiver Functions and Default Settings

Function/Setting	Description /Notes	Available Settings	Default Setting
<b>Auto-Shutdown Time</b>	Elapsed idle time before receiver automatically shuts itself down	<ul style="list-style-type: none"> <li>• Never</li> <li>• 10 minutes</li> <li>• 20 minutes</li> <li>• 30 minutes</li> <li>• 1 hour</li> <li>• 2 hours</li> <li>• 3 hours</li> <li>• 4 hours</li> </ul>	1 hour
<b>Acceleration Delay</b>	Time between actuation of relays when button is fully depressed	<ul style="list-style-type: none"> <li>• 0 seconds</li> <li>• 0.3 seconds</li> <li>• 1 second</li> <li>• 1.5 seconds</li> <li>• 2 seconds</li> <li>• 3 seconds</li> <li>• 4 seconds</li> </ul>	0 seconds
<b>Second Function of Start Position</b>	Turning key to START after already started.	<ul style="list-style-type: none"> <li>• Sound alarm</li> <li>• Close R0 momentary</li> <li>• Close R0 toggle</li> </ul>	Sound Alarm

### 10.5 F22-J Receiver Function Settings

The table below shows the functions available on the F22-J (Joystick) Receiver, the available settings, and the default settings.

Table 10.5 Joystick Receiver Functions and Default Settings

Function/Setting	Description /Notes	Available Settings	Default Setting
<b>Auto-Shutdown Time</b>	Elapsed idle time before receiver is automatically shut down	<ul style="list-style-type: none"> <li>• Never</li> <li>• 10 minutes</li> <li>• 20 minutes</li> <li>• 30 minutes</li> <li>• 1 hour</li> <li>• 2 hours</li> <li>• 3 hours</li> <li>• 4 hours</li> </ul>	1 hour

<b>Function/Setting</b>	<b>Description /Notes</b>	<b>Available Settings</b>	<b>Default Setting</b>
<b>Joystick 1 X-axis Acceleration Delay</b>	Time between actuation of relays when joystick is moved	<ul style="list-style-type: none"> <li>• 0 seconds</li> <li>• 0.3 seconds</li> <li>• 0.5 seconds</li> <li>• 0.8 seconds</li> <li>• 1 second</li> <li>• 1.3 seconds</li> <li>• 1.6 seconds</li> <li>• 1.8 seconds</li> <li>• 2.1 seconds</li> <li>• 2.4 seconds</li> <li>• 2.6 seconds</li> <li>• 2.9 second</li> <li>• 3.1 seconds</li> <li>• 3.4 seconds</li> <li>• 3.7 seconds</li> <li>• 3.9 seconds</li> </ul>	0.5 seconds
<b>Joystick 1 Y-axis Acceleration Delay</b>			
<b>Joystick 2 X-axis Acceleration Delay</b>			
<b>Joystick 1 Y-axis Acceleration Delay</b>			
<b>Acceleration Delay for Buttons 1 to 6 Relays</b>	Time between actuation of relays when button is fully depressed	<ul style="list-style-type: none"> <li>• 0 seconds</li> <li>• 0.3 seconds</li> <li>• 0.5 seconds</li> <li>• 0.8 seconds</li> <li>• 1 second</li> <li>• 2 seconds</li> <li>• 2.1 seconds</li> <li>• 2.4 seconds</li> <li>• 2.6 seconds</li> <li>• 2.9 seconds</li> <li>• 3 seconds</li> <li>• 3.1 seconds</li> <li>• 3.4 seconds</li> <li>• 3.7 seconds</li> <li>• 3.9 seconds</li> <li>• 5 seconds</li> </ul>	0 seconds
<b>Second Function of Start Position</b>	Turning key to START after already started	<ul style="list-style-type: none"> <li>• Sound alarm</li> <li>• Close R0 momentary</li> <li>• Close R0 toggle</li> </ul>	Sound alarm

**THIS PAGE INTENTIONALLY LEFT BLANK**



## Chapter 11 Alarm Codes

This Chapter provides a listing of Alarm Codes to be used during diagnostics and repair activities. Please refer to Chapter 6 for troubleshooting information.

1. If the F22 detects an error, an alarm tone may sound. The alarm tones are given in Morse code, where “.” (dot) indicates a short alarm for a duration of 0.26 second and “—” (dash) a long alarm for a duration of 0.78 second. The interval between each alarm tone is 0.26 second.
2. If the unit’s self-diagnostics detect an error and sound the alarm tones, then the unit will be disabled and will not function until the malfunction is corrected.



**Maintenance technicians can use these error codes for troubleshooting, however the best solution is usually replacement of the defective module.**

**Table 11.1: Alarm Codes for Transmitters**

Item	Error Message		Description	Possible Correction
		Alarm Code		
1	E	.	Low Battery (warning)	Replace batteries.
2	R	.-.	Batteries excessively low	Replace batteries.
3	F	...-	Pushbutton Malfunction (shorted)	1. Release all pushbuttons and start key when inserting batteries. 2. Replace the encoder module
4	X	-...-	Joystick 1 Forward and Backward Malfunction	Replace Joystick 1.
5	K	-...-	Joystick 1 Left and Right Malfunction	Replace Joystick 1.
6	Y	-...-	Joystick 2 Forward and Backward Malfunction	Replace Joystick 2.
7	I	.....	Joystick 2 Left and Right Malfunction	Replace Joystick 2.
8	S	...	RF Module Malfunction	1. Ensure antenna is tight. 2. Replace RF module.
9	C	.-...-	EEPROM in handheld transmitter is faulty.	1. Replace the encoder module 2. Reprogram function settings (see Chapter 9).
10	D	-...-	EEPROM in the encoder does not have function settings set or the settings are incomplete (handheld only).	Reprogram function settings (see Chapter 9).
11	H	.....	EEPROM in joystick transmitter is faulty.	1. Replace the encoder module 2. Reprogram function settings (see Chapter 9).

**Table 11.2: Alarm Codes for Receivers**

Item	Error Message		Description	Possible Correction
		Alarm Code		
1	A	. -	UP Relay Coil bad (Hand-held)	Replace the relay module.
2	B	- . . .	Joystick 2 Relay Coil bad	
			U/D 2S Relay Coil bad (Hand-held)	
3	C	- . - .	DOWN Relay Coil bad (Hand-held)	
4	D	- . .	EAST Relay Coil bad (Hand-held)	
5	E	.	R1~R6 Relay Coil bad (Joystick)	
			E/W 2S Relay Coil bad (Hand-held)	
6	F	. . - .	Joystick 1 Relay Coil bad	
			WEST Relay Coil bad (Hand-held)	
7	G	- - .	SOUTH Relay Coil bad (Hand-held)	
8	H	. . . .	S/N Relay Coil bad (Hand-held)	
9	I	. .	NORTH Relay Coil bad (Hand-held)	
10	J	. - - -	R1 Relay Coil bad (Hand-held)	
11	K	- . -	R1/R2 2S Relay Coil bad (Hand-held)	
12	L	. - . .	R2 Relay Coil bad (Hand-held)	
13	M	- -	R3 Relay Coil bad (Hand-held)	
14	N	- .	R3/R4 Relay Coil bad (Hand-held)	
15	O	- - -	R4 Relay Coil bad (Hand-held)	
16	Q	- - . -	MAIN Relay Coil bad (Hand-held)	

**Table 11.2: Alarm Codes for Receivers**

Item	Error Message		Description	Possible Correction
		Alarm Code		
17	R	. - .	The voltage input exceeds tolerance.	<ol style="list-style-type: none"> <li>1. Disconnect the cable from the receiver.</li> <li>2. Turn off the main power to the crane and check the power-input voltage.</li> <li>3. Check to see that the voltage select plug is at the correct position. (handhelds only)</li> <li>4. Inspect and make sure the power is normal before resuming operation.</li> </ol>
18	S	. . .	RF Circuit malfunction	<ol style="list-style-type: none"> <li>1. Ensure antenna is tight.</li> <li>2. Replace the receiver/decoder module.</li> </ol>
19	Y	- . - -	Interference by the same model of Remote Controller	<ol style="list-style-type: none"> <li>1. Install a less sensitive antenna.</li> <li>2. Change to a new frequency. (Contact ITL or your dealer).</li> </ol>
20	1	. - - - -	Interference by another radio signal on the same frequency	<ol style="list-style-type: none"> <li>1. If the interference is not serious or is short term, start the Remote Controller when the interference is over.</li> <li>2. If the interference is serious, change to a new frequency. (Contact ITL or your dealer).</li> </ol>
21	Z	- - . .	EEPROM in the receiver/decoder does not have function settings set or are incomplete.	Reprogram function settings (see Chapter 9).

**THIS PAGE INTENTIONALLY LEFT BLANK**

## Chapter 12 Principles of Operation of Major Subcomponents

This Chapter provides an overview of the major functions of the F22 Series, including a description of the transmitter, the receiver, and the major parts of each.

### 12.1 Transmitter

The most important components of the transmitter are the Encoder/Button printed circuit board, the RF Module, and an EEPROM.



Figure 8: Encoder/Button PCB

#### 12.1.1 Encoder/Button PCB

This module is the heart of the transmitter. It contains the pushbuttons, power control circuitry, micro-controller, and EEPROM (see Figure 8). The micro-controller encodes the information from the pushbuttons, along with security code and error correction data, into a serial data stream. This data stream, after passing through an audio-frequency-shift-keying circuit, is sent to the transmitter RF module.

#### 12.1.2 Transmitter RF Module

This module is a narrowband FM transmitter with a digitally synthesized frequency output using a phase locked loop circuit (see Figure 9).

#### 12.1.3 EEPROM

This component, found on both the Encoder/Button PCB and Receiver/Decoder Module, contains all of the programming and security code information used by the micro-controller. It is a non-volatile memory device, meaning that it does not require constant supply of power to hold its contents.



Figure 9:  
Transmitter RF  
Module

## 12.2 Receiver

The most important components of the receiver are the Receiver/Decoder Module, the Relay printed circuit board, the LED printed circuit board, the EEPROM, the Mainline Indicator printed circuit board, and the Run/Test Switch.

### 12.2.1 Receiver/Decoder Module

This module combines a narrowband FM receiver, the frequency of which is digitally synthesized, with a decoder circuit, which converts the audio signal from the receiver to a serial data stream of relay commands. It contains a micro-controller, which examines the incoming signal and determines, by means of the security code and other information, whether it contains valid commands to change the state of the relays. It then issues these commands to the Relay PCB.

### 12.2.2 Relay PCB

This module latches the serial relay command data and drives the output relays. It also contains the power supply for the rest of the receiver.

### 12.2.3 LED PCB

This module displays the state of all of the receiver's relays by means of green LEDs (see Figure 10).

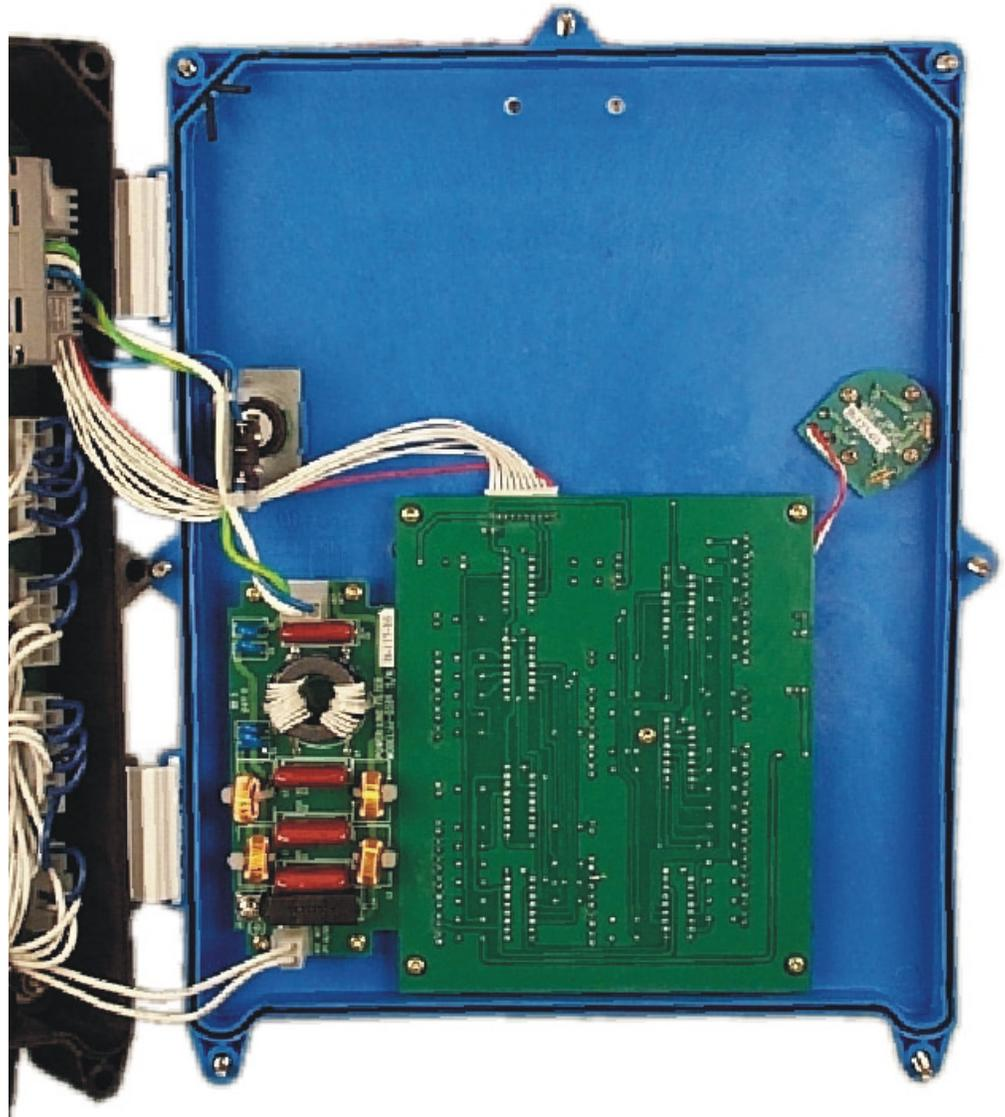

Figure 10: LED Printed Circuit Board on Joystick Receiver

### 12.2.4 Mainline Indicator Lamp PCB

This module indicates, by means of several bright red LEDs, when the mainline relay is activated and the unit is ready to operate.

### 12.2.5 Run/Test Switch

This switch, part of the Relay PCB, interrupts the flow of power to the operating coils of the relays, thus rendering them inoperative. The LED PCB is unaffected by this switch, and can be used to test the equipment without movement of the crane. The switch functions in the same manner for both the handheld and joystick models (see Figures 11 and 12).

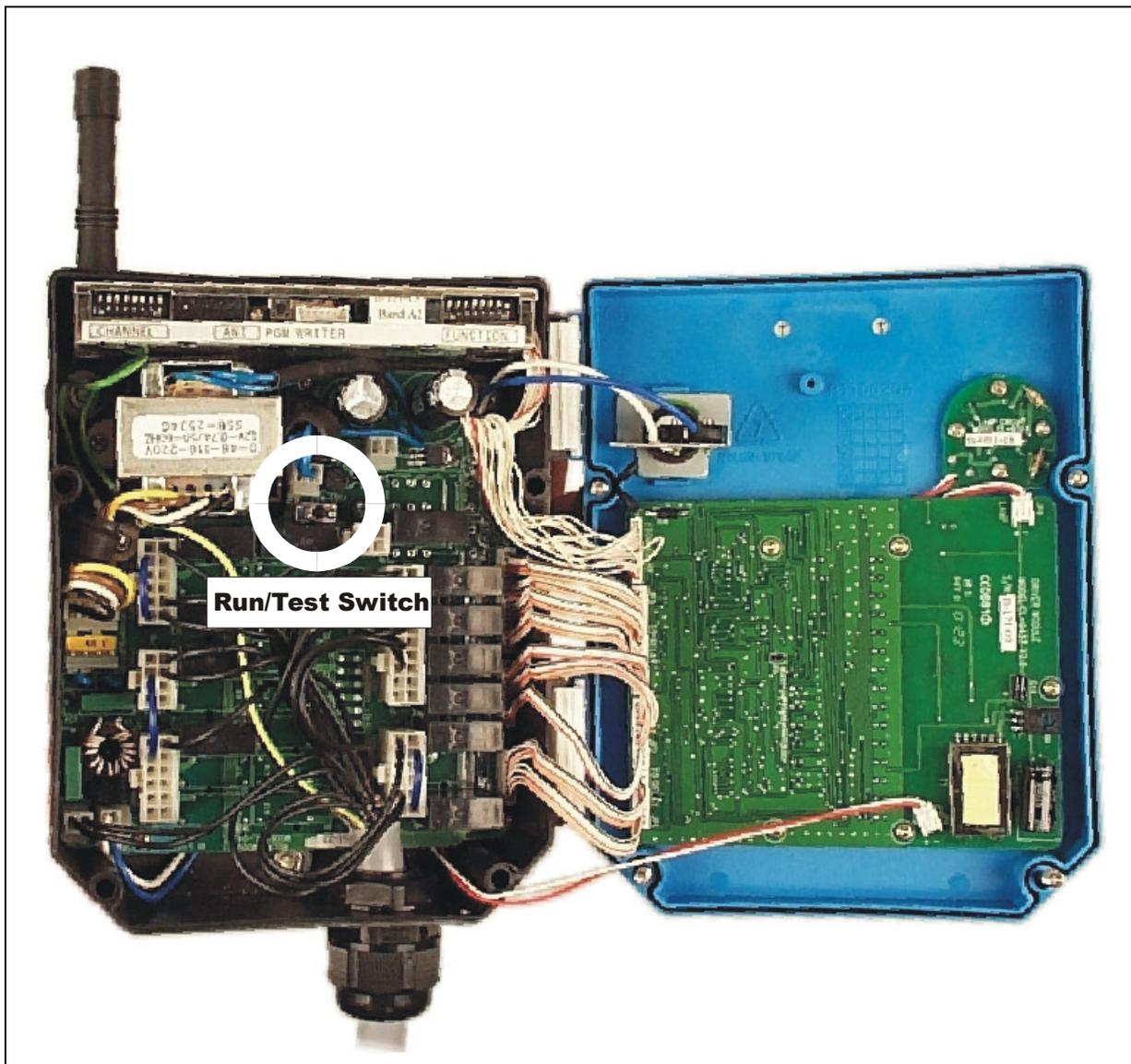

Figure 11: Location of Run/Test Switch in Receiver for Handhelds

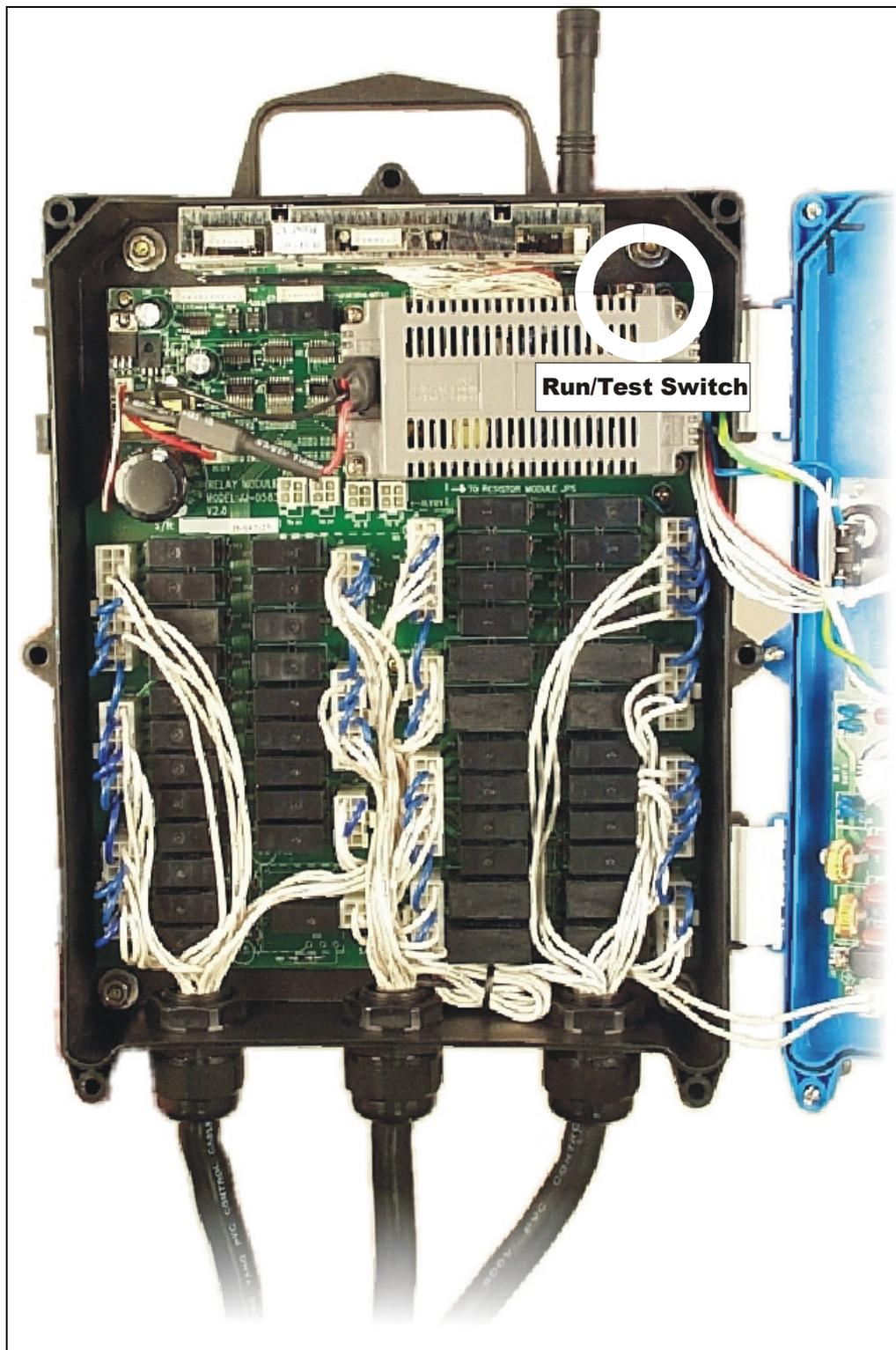

Figure 12: Location of Run/Test Switch in Receiver for Joystick



## Chapter 13 Customer-Specific Information

### 13.1 Serial Numbers and Security Codes

An F22 System typically includes one receiver and two transmitters, however, it is possible to include more components such as additional transmitters or receivers. Each component has a unique serial number, composed of two parts separated by a dash. The security code (system serial number) is the first part, and the component serial number is the second part. Serial numbers are used to track individual components for repair and warranty purposes. Security codes are used to track system-wide parameters such as frequency and programming information.

When you purchase a system, record the serial and system numbers below for later reference:

***List of Serial Numbers Here***

### 13.2 Function Settings

The F22 Series of Industrial Radio Remote Controllers are customizable to meet the specific needs of each user. Chapter 10 of this Manual provides a detailed list of the available functions and settings, and the Technical Sheets in Chapter 14 provide a summary list.

When you purchase a system, record the custom settings below for later reference:

***List of Function Settings Here***

**THIS PAGE INTENTIONALLY LEFT BLANK**

## Chapter 14 Product Technical Sheets

This Chapter contains tables of transmitters, receivers, accessories, and Technical Sheets for each system model.

### 14.1 F22 Series Systems

The table below lists all F22 Systems by feature and application. Technical Sheets for each system are provided later in this Chapter.

Table 14-1. Available Models by Feature and Applications

<b>System Model No.</b>	<b>Transmitter Type</b>	<b>Buttons</b>	<b>General Application</b>
<b>F22-2S</b>	Mini	Up/Down	Hoist or Winch, Single-Speed
<b>F22-4S</b>	Mini	Up/Down, East/West	Monorail, Single-Speed
<b>F22-6S</b>	Mini	Up/Down, East/West, North/South	3-Motion Crane, Single-Speed
<b>F22-12S</b>	Mini	Up/Down, East/West, North/South, 1, 2, 3, 4, 5, 6	6-Motion Crane, Single-Speed or A, B, A+B type applications
<b>F22-2S1</b>	N1	Up/Down	Hoist or Winch, Single-Speed
<b>F22-4S1</b>	N1	Up/Down, East/West	Monorail, Single-Speed
<b>F22-6S1</b>	N1	Up/Down, East/West, North/South	3-Motion Crane, Single-Speed
<b>F22-10S1</b>	N1	Up/Down, East/West, North/South, 1, 2, 5, 6	5-Motion Crane, Single-Speed or A, B, A+B type applications
<b>F22-2D</b>	Mini	Up/Down	Hoist, Two-Speed
<b>F22-4D</b>	Mini	Up/Down, East/West	Monorail, Two-Speed
<b>F22-6D</b>	Mini	Up/Down, East/West, North/South	3-Motion Crane, Two-Speed
<b>F22-12D</b>	Mini	Up/Down, East/West, North/South, 1, 2, 3, 4, 5, 6	6-Motion Crane, Two-Speed or A, B, A+B type applications
<b>F22-2D1</b>	N1	Up/Down	Hoist, Two-Speed
<b>F22-4D1</b>	N1	Up/Down, East/West	Monorail, Two-Speed
<b>F22-6D1</b>	N1	Up/Down, East/West, North/South	3-Motion Crane, Two-Speed
<b>F22-10D1</b>	N1	Up/Down, East/West, North/South, 1, 2, 5, 6	5-Motion Crane, Two-Speed or A, B, A+B type applications
<b>F22-J</b>	Joystick (Belly-Box) (includes 2 transmitters)	2 independent joysticks, 4 dial switches, 6 pushbutton switches	Extensive applications, refer to Technical Sheets.

## 14.2 F22 Transmitter and Receiver Part Numbers

The table below lists the correct transmitter and receiver part numbers for each system model number:

Table 14-2: Available F22 Transmitters and Receivers

System Model No.	Transmitter Part No.	Receiver Part No.
<b>F22-2S</b>	F22-2S-TX	F22-6S-RX
<b>F22-2S1</b>	F22-2S1-TX	
<b>F22-4S</b>	F22-4S-TX	
<b>F22-4S1</b>	F22-4S1-TX	
<b>F22-6S</b>	F22-6S-TX	
<b>F22-6S1</b>	F22-6S1-TX	
<b>F22-10S1</b>	F22-10S1-TX	F22-12S-RX
<b>F22-12S</b>	F22-12S-TX	F22-6D-RX
<b>F22-2D</b>	F22-2D-TX	
<b>F22-2D1</b>	F22-2D1-TX	
<b>F22-4D</b>	F22-4D-TX	
<b>F22-4D1</b>	F22-4D1-TX	
<b>F22-6D</b>	F22-6D-TX	
<b>F22-6D1</b>	F22-6D1-TX	
<b>F22-10D1</b>	F22-10D1-TX	
<b>F22-12D</b>	F22-12D-TX	F22-12D-RX
<b>F22-J</b>	F22-J-TX	F22-J-RX

## 14.3 F22 Series: Accessories

The table below provides a summary of available optional accessories used to enhance the function and operation of the F22 Series.

Table 14-3: Available Optional Accessories

Model	Application	Feature
<b>24 Volt Converter</b>	This optional accessory allows the unit to be used with 24 volt input power, instead of the standard 110/220 volts.	Permits the unit to be used in 24 volt applications.
<b>Extended Antenna Kit</b>	This optional accessory allows the standard antennas to be extended to a more suitable position to the operator. This can be used when the location for mounting the receiver could cause a problem with the signal coming from the transmitter, such as being mounted in a box on the crane	This provides flexibility in where the Receiver can be installed within a work environment. See Section 14.4 for details.

## 14.4 Extended Antenna Kit

The table below lists the part numbers for Extended Antenna Kits based on system model numbers:

Table 14-4: Extended Antenna Kit Part Numbers

<b>Extended Antenna Kit Part No.</b>	<b>Description</b>	<b>Used on Models</b>
<b>24B0102</b>	Extended antenna kit with 2 foot coax cable and antenna.	All Handheld models
<b>24B0103</b>	Extended antenna kit with 3 foot coax cable and antenna.	All Handheld models
<b>24B0104</b>	Extended antenna kit with 4 foot coax cable and antenna.	All Handheld models
<b>24B0105</b>	Extended antenna kit with 5 foot coax cable and antenna.	All Handheld models
<b>24B0106</b>	Extended antenna kit with 6 foot coax cable and antenna.	All Handheld models
<b>24B0110</b>	Extended antenna kit with 10 foot coax cable and antenna.	All Handheld models
<b>24B0120</b>	Extended antenna kit with 20 foot coax cable and antenna.	All Handheld models
<b>24B0100</b>	Extended antenna kit with custom length of coax cable and antenna.	All Handheld models
<b>24B0204</b>	Extended antenna kit with 4 foot coax cable and antenna	F22-J
<b>24B0220</b>	Extended antenna kit with 20 foot coax cable and antenna.	F22-J
<b>24B0200</b>	Extended antenna kit with custom length of coax cable and antenna.	F22-J

## 14.5 Technical and Programming Sheets

The rest of this Chapter consists of Technical Sheets and Programming Sheets for each model listed in Table 14-1. Technical Sheets contain detailed product specifications including wiring schematics and receiver mounting templates.

Programming Sheets are intended to:

- List the available function settings
- Provide a method for the user to select programming options.

The Legend below indicates how to complete the Programming Sheets:

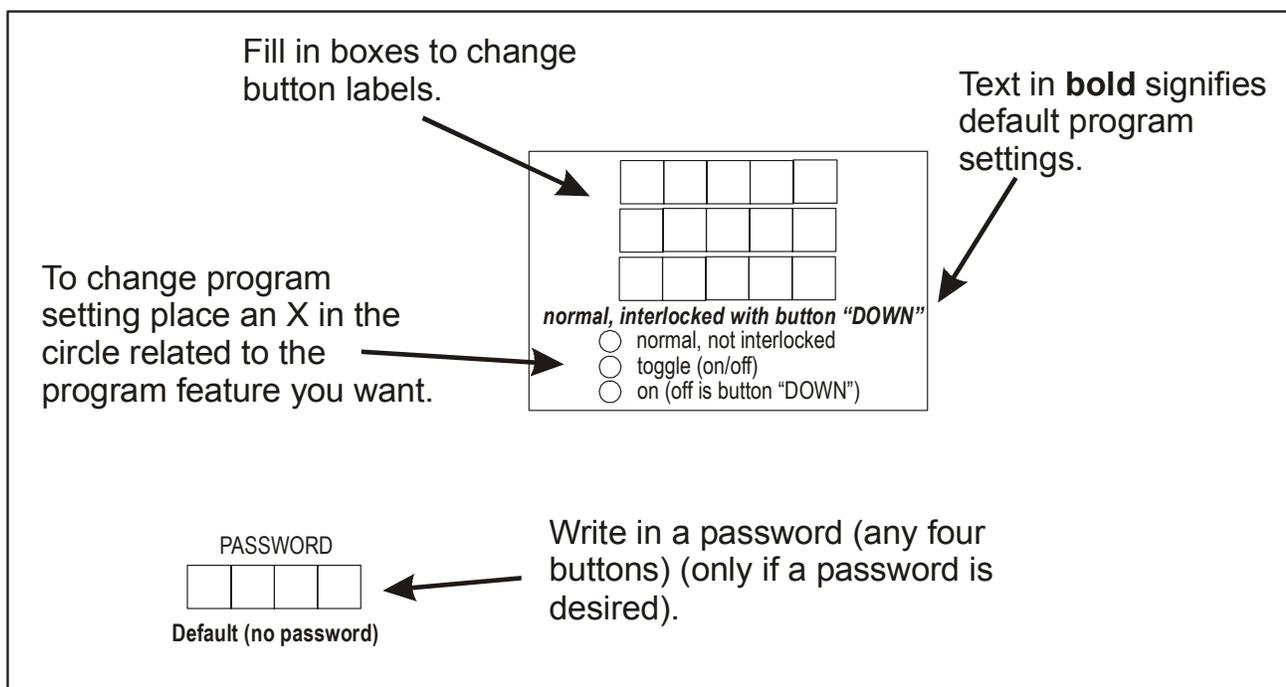

Figure 13: Programming Sheet Legend

Note: If you want your unit to include programming different from the default programming, then mail or fax a completed Programming Sheet with your order to:

**Intercontinental Technologies, Ltd.**

558-2 Plate Drive  
East Dundee, IL 60118

Phone: (800) 382-3558

Fax: (847) 426-9724

## Technical Sheet: F22-2S

### General Specifications

**Typical application:** 1 motion, 1 step, hoist.

**Operating Distance:** 500+feet

**Frequency:** 450Mhz band

**Number of available**

**frequencies:** 256

**Frequency generation:**

Synthesized phase lock loop.

**Security coding:** 4 billion

unique security codes

available.

**Environment rating:** Outdoor

use, IP65

**Licensing:** FCC certified, no

license needed.

**Warranty:** 1 year, see manual

**Temperature Rating:** -35 to

+75°C

### Receiver Specifications

**Size:** 10" x 6.5" x 4.5", not including antenna or cable

**Part #:** F22-6S-RX

**Power supply input:** 120VAC (240VAC and 12 or 24V, AC or DC available)

**Relay ratings:** 5amp/250VAC

**Error notification:** audible

Morse Code via horn

**Weight:** 7 lbs.

**Includes:** Loud horn, large mainline indicator, emergency stop disconnect button. Totally pre-cabled.

**Accessories available:**

Extended antenna kit for mounting receiver inside cabinets or mounting antenna in better position for reception.

### Physical mounting specifications below

#### Receiver mounting

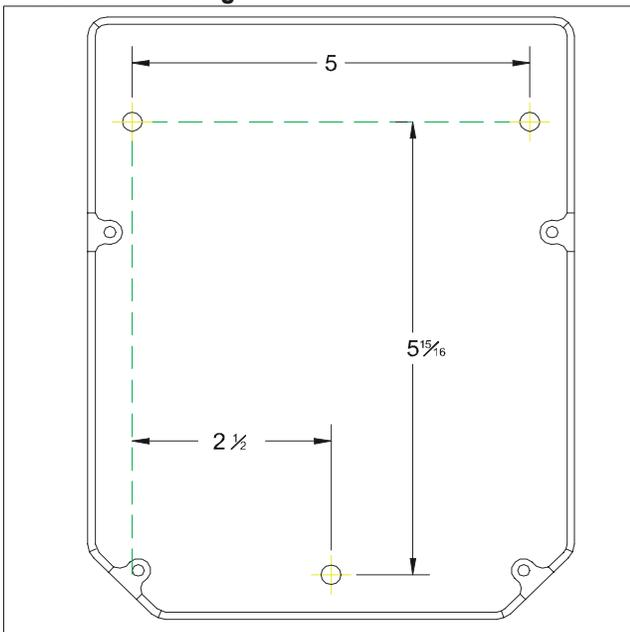

### Transmitter Specifications

**Part #:** F22-2S-TX

**Transmitters:** 2 supplied standard.

**Size:** W 2.5" x D 2.5" x L 6.5" (not including antenna)

**Weight:** less than 1 lb.

**Material:** shock resistant, fiber reinforced nylon

**Power source:** 4 AA alkaline batteries.

**Battery power indication:** LED and audible alarm.

**Buttons:** 2 programmable, 1 step, plus start and stop. See programming and custom labeling sheet. Rated to 2 million cycles

**Start key:** Removable

**Stop Button:** mushroom style

**Error notification:** audible Morse Code via buzzer

**Includes:** shoulder straps and 4 AA batteries.



#### Receiver schematic

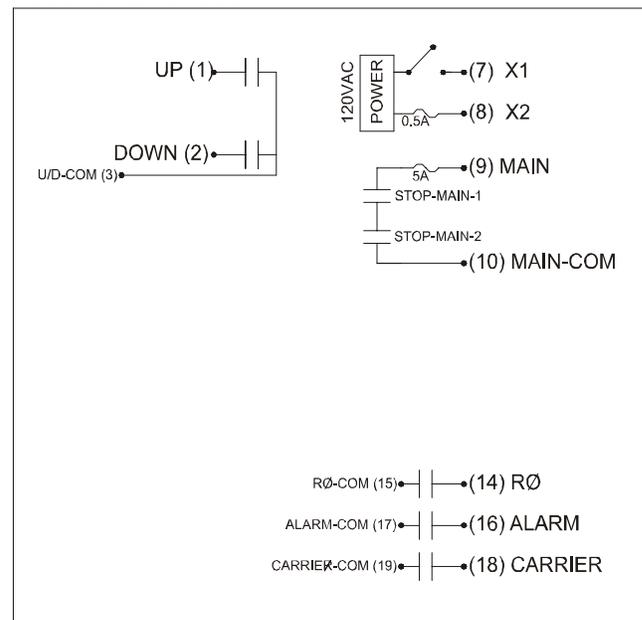

## Programming Sheet: F22-2S

**Acceleration delay for all button relays.**  
**Default setting of ZERO**

.3 seconds     2 seconds  
 1 second     3 seconds  
 1.5 seconds     4 seconds

**PASSWORD**  
[ ][ ][ ][ ]  
**Default (no password)**

**UP**    **DOWN**

**normal, interlocked with button "DOWN"**

normal, not interlocked  
 toggle (on/off)

**normal, interlocked with button "UP"**

normal, not interlocked  
 toggle (on/off)

**Second function of START position**  
**Sound Alarm**

Close RØ momentary  
 Close RØ toggle

**Auto Shut Down time**  
**Default setting of 1 hour**

never  
 10 minutes  
 20 minutes  
 30 minutes  
**1 hour**  
 2 hours  
 3 hours  
 4 hours



## Technical Sheet: F22-4S

### General Specifications

**Typical application:** 2 motion, 1 step, monorail.

**Operating Distance:** 500+feet

**Frequency:** 450Mhz band

**Number of available frequencies:** 256

**Frequency generation:** Synthesized phase lock loop.

**Security coding:** 4 billion unique security codes available.

**Environment rating:** Outdoor use, IP65

**Licensing:** FCC certified, no license needed.

**Warranty:** 1 year, see manual

**Temperature Rating:** -35 to +75°C

### Receiver Specifications

**Size:** 10" x 6.5" x 4.5", not including antenna or cable

**Part #:** F22-6S-RX

**Power supply input:** 120VAC (240VAC and 12 or 24V, AC or DC available)

**Relay ratings:** 5amp/250VAC

**Error notification:** audible Morse Code via horn

**Weight:** 7 lbs.

**Includes:** Loud horn, large mainline indicator, emergency stop disconnect button. Totally pre-cabled.

**Accessories available:** Extended antenna kit for mounting receiver inside cabinets or mounting antenna in better position for reception.

### Transmitter Specifications

**Part #:** F22-4S-TX

**Transmitters:** 2 supplied standard.

**Size:** W 2.5" x D 2.5" x L 6.5" (not including antenna)

**Weight:** less than 1 lb.

**Material:** shock resistant, fiber reinforced nylon

**Power source:** 4 AA alkaline batteries.

**Battery power indication:** LED and audible alarm.

**Buttons:** 4 programmable, 1 step, plus start and stop. See programming and custom labeling sheet. Rated to 2 million cycles

**Start key:** Removable

**Stop Button:** mushroom style

**Error notification:** audible Morse Code via buzzer

**Includes:** shoulder straps and



### Physical mounting specifications below

#### Receiver mounting

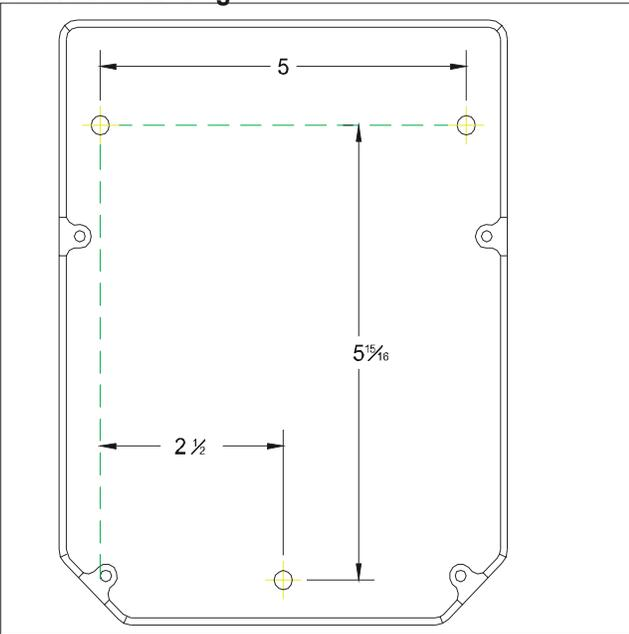

#### Receiver schematic

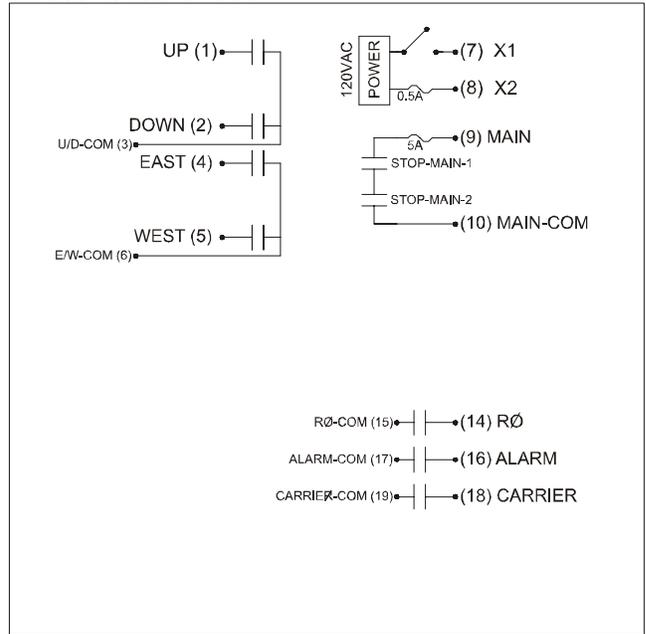

## Programming Sheet: F22-4S

<div style="border: 1px solid black; padding: 5px; margin-bottom: 5px;"> <table border="1" style="width: 100%; height: 30px; border-collapse: collapse;"> <tr><td style="width: 25px; height: 20px;"></td><td style="width: 25px; height: 20px;"></td><td style="width: 25px; height: 20px;"></td><td style="width: 25px; height: 20px;"></td></tr> <tr><td style="width: 25px; height: 20px;"></td><td style="width: 25px; height: 20px;"></td><td style="width: 25px; height: 20px;"></td><td style="width: 25px; height: 20px;"></td></tr> </table> <p><b>normal, interlocked with button "DOWN"</b></p> <p><input type="radio"/> normal, not interlocked</p> <p><input type="radio"/> toggle (on/off)</p> </div> <div style="border: 1px solid black; padding: 5px;"> <table border="1" style="width: 100%; height: 30px; border-collapse: collapse;"> <tr><td style="width: 25px; height: 20px;"></td><td style="width: 25px; height: 20px;"></td><td style="width: 25px; height: 20px;"></td><td style="width: 25px; height: 20px;"></td></tr> <tr><td style="width: 25px; height: 20px;"></td><td style="width: 25px; height: 20px;"></td><td style="width: 25px; height: 20px;"></td><td style="width: 25px; height: 20px;"></td></tr> </table> <p><b>normal, interlocked with button "WEST"</b></p> <p><input type="radio"/> normal, not interlocked</p> <p><input type="radio"/> toggle (on/off)</p> </div>																	<p>PASSWORD</p> <table border="1" style="width: 100%; height: 20px; border-collapse: collapse;"> <tr><td style="width: 25px; height: 15px;"></td><td style="width: 25px; height: 15px;"></td><td style="width: 25px; height: 15px;"></td><td style="width: 25px; height: 15px;"></td></tr> </table> <p>Default (no password)</p> <div style="display: flex; justify-content: space-around; align-items: center; margin: 10px 0;"> <div style="border: 1px solid black; padding: 10px 20px;">UP</div> <div style="border: 1px solid black; padding: 10px 20px;">DOWN</div> </div> <div style="display: flex; justify-content: space-around; align-items: center; margin: 10px 0;"> <div style="border: 1px solid black; padding: 10px 20px;">EAST</div> <div style="border: 1px solid black; padding: 10px 20px;">WEST</div> </div> <p><b>Auto Shut Down time</b> Default setting of 1 hour</p> <p><input type="radio"/> never</p> <p><input type="radio"/> 10 minutes</p> <p><input type="radio"/> 20 minutes</p> <p><input type="radio"/> 30 minutes</p> <p><input checked="" type="radio"/> <b>1 hour</b></p> <p><input type="radio"/> 2 hours</p> <p><input type="radio"/> 3 hours</p> <p><input type="radio"/> 4 hours</p>					<div style="border: 1px solid black; padding: 5px; margin-bottom: 5px;"> <table border="1" style="width: 100%; height: 30px; border-collapse: collapse;"> <tr><td style="width: 25px; height: 20px;"></td><td style="width: 25px; height: 20px;"></td><td style="width: 25px; height: 20px;"></td><td style="width: 25px; height: 20px;"></td></tr> <tr><td style="width: 25px; height: 20px;"></td><td style="width: 25px; height: 20px;"></td><td style="width: 25px; height: 20px;"></td><td style="width: 25px; height: 20px;"></td></tr> </table> <p><b>normal, interlocked with button "UP"</b></p> <p><input type="radio"/> normal, not interlocked</p> <p><input type="radio"/> toggle (on/off)</p> </div> <div style="border: 1px solid black; padding: 5px;"> <table border="1" style="width: 100%; height: 30px; border-collapse: collapse;"> <tr><td style="width: 25px; height: 20px;"></td><td style="width: 25px; height: 20px;"></td><td style="width: 25px; height: 20px;"></td><td style="width: 25px; height: 20px;"></td></tr> <tr><td style="width: 25px; height: 20px;"></td><td style="width: 25px; height: 20px;"></td><td style="width: 25px; height: 20px;"></td><td style="width: 25px; height: 20px;"></td></tr> </table> <p><b>normal, interlocked with button "EAST"</b></p> <p><input type="radio"/> normal, not interlocked</p> <p><input type="radio"/> toggle (on/off)</p> </div>																
<p><b>Second function of START position</b> <b>Sound Alarm</b></p> <p><input type="radio"/> Close RØ momentary</p> <p><input type="radio"/> Close RØ toggle</p>																																						

## Technical Sheet: F22-6S

### General Specifications

**Typical application:** 3 motion, 1 step, overhead crane.

**Operating Distance:** 500+feet

**Frequency:** 450Mhz band

**Number of available frequencies:** 256

**Frequency generation:** Synthesized phase lock loop.

**Security coding:** 4 billion unique security codes available.

**Environment rating:** Outdoor use, IP65

**Licensing:** FCC certified, no license needed.

**Warranty:** 1 year, see manual

**Temperature Rating:** -35 to +75°C

### Receiver Specifications

**Size:** 10" x 6.5" x 4.5" not including antenna or cable

**Part #:** F22-6S-RX

**Power supply input:** 120VAC (240VAC and 12 or 24V, AC or DC available)

**Relay ratings:** 5amp/250VAC

**Error notification:** audible Morse Code via horn

**Weight:** 7 lbs.

**Includes:** Loud horn, large mainline indicator, emergency stop disconnect button. Totally pre-cabled.

**Accessories available:** Extended antenna kit for mounting receiver inside cabinets or mounting antenna in better position for reception.

### Physical mounting specifications below

### Receiver mounting

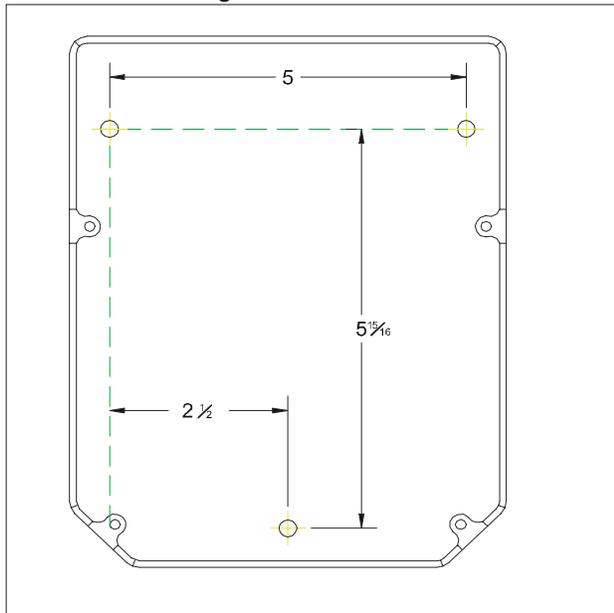

### Transmitter Specifications

**Part #:** F22-6S-TX

**Transmitters:** 2 supplied standard.

**Size:** W 2.5" x D 2.5" x L 6.5" (not including antenna)

**Weight:** less than 1 lb.

**Material:** shock resistant, fiber reinforced nylon

**Power source:** 4 AA alkaline batteries.

**Battery power indication:** LED and audible alarm.

**Buttons:** 6 programmable, 1 step, plus start and stop. See programming and custom labeling sheet. Rated to 2 million cycles

**Start key:** Removable

**Stop Button:** mushroom style

**Error notification:** audible Morse Code via buzzer

**Includes:** shoulder straps and 4 AA batteries.

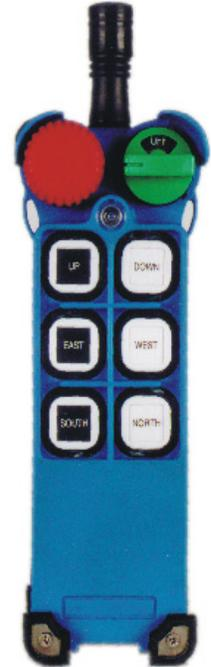

### Receiver schematic

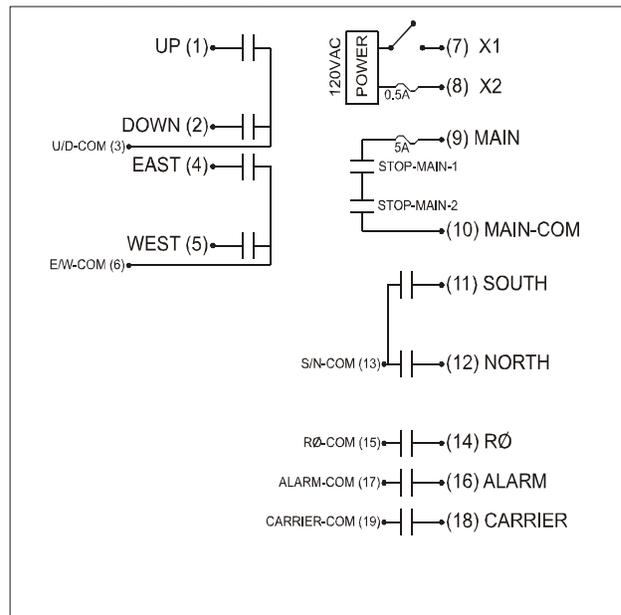

## Programming Sheet: F22-6S

<div style="border: 1px solid black; padding: 5px; margin-bottom: 5px;"> <table style="width: 100%; border-collapse: collapse;"> <tr><td style="width: 25px; height: 20px;"></td><td style="width: 25px; height: 20px;"></td><td style="width: 25px; height: 20px;"></td><td style="width: 25px; height: 20px;"></td></tr> <tr><td style="width: 25px; height: 20px;"></td><td style="width: 25px; height: 20px;"></td><td style="width: 25px; height: 20px;"></td><td style="width: 25px; height: 20px;"></td></tr> <tr><td style="width: 25px; height: 20px;"></td><td style="width: 25px; height: 20px;"></td><td style="width: 25px; height: 20px;"></td><td style="width: 25px; height: 20px;"></td></tr> </table> <p><b>normal, interlocked with button "DOWN"</b></p> <p><input type="radio"/> normal, not interlocked</p> <p><input type="radio"/> toggle (on/off)</p> </div> <div style="border: 1px solid black; padding: 5px; margin-bottom: 5px;"> <table style="width: 100%; border-collapse: collapse;"> <tr><td style="width: 25px; height: 20px;"></td><td style="width: 25px; height: 20px;"></td><td style="width: 25px; height: 20px;"></td><td style="width: 25px; height: 20px;"></td></tr> <tr><td style="width: 25px; height: 20px;"></td><td style="width: 25px; height: 20px;"></td><td style="width: 25px; height: 20px;"></td><td style="width: 25px; height: 20px;"></td></tr> <tr><td style="width: 25px; height: 20px;"></td><td style="width: 25px; height: 20px;"></td><td style="width: 25px; height: 20px;"></td><td style="width: 25px; height: 20px;"></td></tr> </table> <p><b>normal, interlocked with button "WEST"</b></p> <p><input type="radio"/> normal, not interlocked</p> <p><input type="radio"/> toggle (on/off)</p> </div> <div style="border: 1px solid black; padding: 5px;"> <table style="width: 100%; border-collapse: collapse;"> <tr><td style="width: 25px; height: 20px;"></td><td style="width: 25px; height: 20px;"></td><td style="width: 25px; height: 20px;"></td><td style="width: 25px; height: 20px;"></td></tr> <tr><td style="width: 25px; height: 20px;"></td><td style="width: 25px; height: 20px;"></td><td style="width: 25px; height: 20px;"></td><td style="width: 25px; height: 20px;"></td></tr> <tr><td style="width: 25px; height: 20px;"></td><td style="width: 25px; height: 20px;"></td><td style="width: 25px; height: 20px;"></td><td style="width: 25px; height: 20px;"></td></tr> </table> <p><b>normal, interlocked with button "NORTH"</b></p> <p><input type="radio"/> normal, not interlocked</p> <p><input type="radio"/> toggle (on/off)</p> <p><input type="radio"/> inching .1 sec</p> <p><input type="radio"/> inching .2 sec</p> <p><input type="radio"/> inching .3 sec</p> <p><input type="radio"/> inching .4 sec</p> <p><input type="radio"/> inching .5 sec</p> </div>																																					<p>PASSWORD</p> <table style="width: 100%; border-collapse: collapse;"> <tr><td style="width: 25px; height: 20px;"></td><td style="width: 25px; height: 20px;"></td><td style="width: 25px; height: 20px;"></td><td style="width: 25px; height: 20px;"></td></tr> </table> <p><b>Default (no password)</b> Note: South and North may not be used in a password.</p> <table style="width: 100%; text-align: center;"> <tr><td style="width: 50px; height: 50px; border: 1px solid black;">UP</td><td style="width: 50px; height: 50px; border: 1px solid black;">DOWN</td></tr> <tr><td style="width: 50px; height: 50px; border: 1px solid black;">EAST</td><td style="width: 50px; height: 50px; border: 1px solid black;">WEST</td></tr> <tr><td style="width: 50px; height: 50px; border: 1px solid black;">SOUTH</td><td style="width: 50px; height: 50px; border: 1px solid black;">NORTH</td></tr> </table> <p><b>Auto Shut Down time</b> Default setting of 1 hour</p> <p><input type="radio"/> never</p> <p><input type="radio"/> 10 minutes</p> <p><input type="radio"/> 20 minutes</p> <p><input type="radio"/> 30 minutes</p> <p><input checked="" type="radio"/> 1 hour</p> <p><input type="radio"/> 2 hours</p> <p><input type="radio"/> 3 hours</p> <p><input type="radio"/> 4 hours</p>					UP	DOWN	EAST	WEST	SOUTH	NORTH	<div style="border: 1px solid black; padding: 5px; margin-bottom: 5px;"> <table style="width: 100%; border-collapse: collapse;"> <tr><td style="width: 25px; height: 20px;"></td><td style="width: 25px; height: 20px;"></td><td style="width: 25px; height: 20px;"></td><td style="width: 25px; height: 20px;"></td></tr> <tr><td style="width: 25px; height: 20px;"></td><td style="width: 25px; height: 20px;"></td><td style="width: 25px; height: 20px;"></td><td style="width: 25px; height: 20px;"></td></tr> <tr><td style="width: 25px; height: 20px;"></td><td style="width: 25px; height: 20px;"></td><td style="width: 25px; height: 20px;"></td><td style="width: 25px; height: 20px;"></td></tr> </table> <p><b>normal, interlocked with button "UP"</b></p> <p><input type="radio"/> normal, not interlocked</p> <p><input type="radio"/> toggle (on/off)</p> </div> <div style="border: 1px solid black; padding: 5px; margin-bottom: 5px;"> <table style="width: 100%; border-collapse: collapse;"> <tr><td style="width: 25px; height: 20px;"></td><td style="width: 25px; height: 20px;"></td><td style="width: 25px; height: 20px;"></td><td style="width: 25px; height: 20px;"></td></tr> <tr><td style="width: 25px; height: 20px;"></td><td style="width: 25px; height: 20px;"></td><td style="width: 25px; height: 20px;"></td><td style="width: 25px; height: 20px;"></td></tr> <tr><td style="width: 25px; height: 20px;"></td><td style="width: 25px; height: 20px;"></td><td style="width: 25px; height: 20px;"></td><td style="width: 25px; height: 20px;"></td></tr> </table> <p><b>normal, interlocked with button "EAST"</b></p> <p><input type="radio"/> normal, not interlocked</p> <p><input type="radio"/> toggle (on/off)</p> </div> <div style="border: 1px solid black; padding: 5px;"> <table style="width: 100%; border-collapse: collapse;"> <tr><td style="width: 25px; height: 20px;"></td><td style="width: 25px; height: 20px;"></td><td style="width: 25px; height: 20px;"></td><td style="width: 25px; height: 20px;"></td></tr> <tr><td style="width: 25px; height: 20px;"></td><td style="width: 25px; height: 20px;"></td><td style="width: 25px; height: 20px;"></td><td style="width: 25px; height: 20px;"></td></tr> <tr><td style="width: 25px; height: 20px;"></td><td style="width: 25px; height: 20px;"></td><td style="width: 25px; height: 20px;"></td><td style="width: 25px; height: 20px;"></td></tr> </table> <p><b>normal, interlocked with button "SOUTH"</b></p> <p><input type="radio"/> normal, not interlocked</p> <p><input type="radio"/> toggle (on/off)</p> <p><b>Second function of START position</b> <b>Sound Alarm</b></p> <p><input type="radio"/> Close RØ momentary</p> <p><input type="radio"/> Close RØ toggle</p> </div>																																				
UP	DOWN																																																																																			
EAST	WEST																																																																																			
SOUTH	NORTH																																																																																			

## Technical Sheet: F22-12S

### General Specifications

**Typical application:** Up to 6 motions, 1 step, overhead crane. Also A, B, A+B applications. Works great with variable frequency drives.

**Operating Distance:** 500+feet  
**Frequency:** 450Mhz band  
**Number of available frequencies:** 256  
**Frequency generation:** Synthesized phase lock loop.  
**Security coding:** 4 billion unique security codes available.  
**Environment rating:** Outdoor use, IP65

**Licensing:** FCC certified, no license needed.  
**Warranty:** 1 year, see manual  
**Temperature Rating:** -35 to +75°C

### Receiver Specifications

**Size:** 10" x 6.5" x 4.5" not including antenna or cable  
**Part #:** F22-12S-RX  
**Power supply input:** 120VAC (240VAC and 12 or 24V, AC or DC available)  
**Relay ratings:** 5amp/250VAC

**Error notification:** audible Morse Code via horn  
**Weight:** 7 lbs.  
**Includes:** Loud horn, large mainline indicator, emergency stop disconnect button. Totally pre-cabled.

**Accessories available:** Extended antenna kit for mounting receiver inside cabinets or mounting antenna in better position for reception.

#### Physical mounting specifications below

### Transmitter Specifications

**Part #:** F22-12S-TX  
**Transmitters:** 2 supplied standard.  
**Size:** W 2.25" x D 2.25" x L 7.25" (not including antenna)  
**Weight:** less than 1 lb.  
**Material:** shock resistant, fiber reinforced nylon

**Power source:** 4 AA alkaline batteries.  
**Battery power indication:** LED and audible alarm.  
**Buttons:** 12 programmable, 1 step, plus start and stop. See programming and custom labeling sheet. Rated to 2 million cycles

**Start key:** Removable  
**Stop Button:** mushroom style  
**Error notification:** audible Morse Code via buzzer  
**Includes:** shoulder straps and 4 AA batteries.

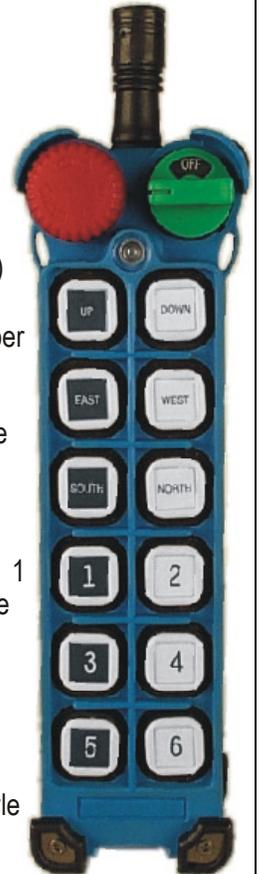

#### Receiver mounting

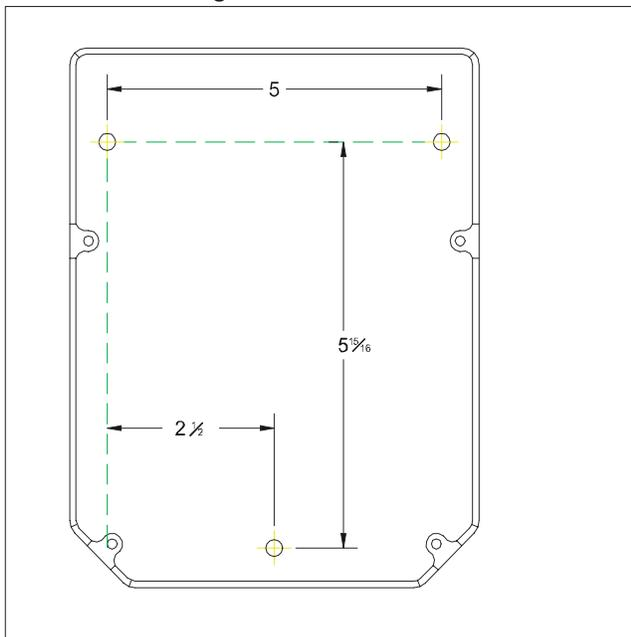

#### Receiver schematic

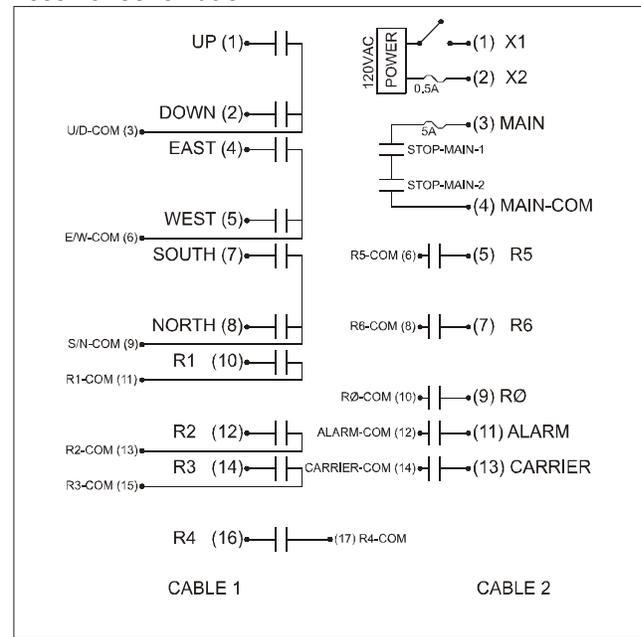

## Programming Sheet: F22-12S

<div style="border: 1px solid black; padding: 5px; margin-bottom: 5px;"> <table border="1" style="width: 100%; height: 30px; border-collapse: collapse;"> <tr><td style="width: 25px; height: 20px;"></td><td style="width: 25px; height: 20px;"></td><td style="width: 25px; height: 20px;"></td><td style="width: 25px; height: 20px;"></td></tr> <tr><td style="width: 25px; height: 20px;"></td><td style="width: 25px; height: 20px;"></td><td style="width: 25px; height: 20px;"></td><td style="width: 25px; height: 20px;"></td></tr> <tr><td style="width: 25px; height: 20px;"></td><td style="width: 25px; height: 20px;"></td><td style="width: 25px; height: 20px;"></td><td style="width: 25px; height: 20px;"></td></tr> </table> <p><b>normal, interlocked with button "DOWN"</b></p> <p><input type="radio"/> normal, not interlocked</p> <p><input type="radio"/> toggle (on/off)</p> </div>													<p><b>Second function of START position</b></p> <p><b>Sound Alarm</b></p> <p><input type="radio"/> Close RØ momentary</p> <p><input type="radio"/> Close RØ toggle</p> <p>PASSWORD</p> <table border="1" style="width: 100%; height: 20px; border-collapse: collapse;"> <tr><td style="width: 25px; height: 15px;"></td><td style="width: 25px; height: 15px;"></td><td style="width: 25px; height: 15px;"></td><td style="width: 25px; height: 15px;"></td></tr> </table> <p><b>Default (no password)</b> Note: 4,5,and 6 may not be used in a password.</p>					<div style="border: 1px solid black; padding: 5px; margin-bottom: 5px;"> <table border="1" style="width: 100%; height: 30px; border-collapse: collapse;"> <tr><td style="width: 25px; height: 20px;"></td><td style="width: 25px; height: 20px;"></td><td style="width: 25px; height: 20px;"></td><td style="width: 25px; height: 20px;"></td></tr> <tr><td style="width: 25px; height: 20px;"></td><td style="width: 25px; height: 20px;"></td><td style="width: 25px; height: 20px;"></td><td style="width: 25px; height: 20px;"></td></tr> <tr><td style="width: 25px; height: 20px;"></td><td style="width: 25px; height: 20px;"></td><td style="width: 25px; height: 20px;"></td><td style="width: 25px; height: 20px;"></td></tr> </table> <p><b>normal, interlocked with button "UP"</b></p> <p><input type="radio"/> normal, not interlocked</p> <p><input type="radio"/> toggle (on/off)</p> </div>												
<div style="border: 1px solid black; padding: 5px; margin-bottom: 5px;"> <table border="1" style="width: 100%; height: 30px; border-collapse: collapse;"> <tr><td style="width: 25px; height: 20px;"></td><td style="width: 25px; height: 20px;"></td><td style="width: 25px; height: 20px;"></td><td style="width: 25px; height: 20px;"></td></tr> <tr><td style="width: 25px; height: 20px;"></td><td style="width: 25px; height: 20px;"></td><td style="width: 25px; height: 20px;"></td><td style="width: 25px; height: 20px;"></td></tr> <tr><td style="width: 25px; height: 20px;"></td><td style="width: 25px; height: 20px;"></td><td style="width: 25px; height: 20px;"></td><td style="width: 25px; height: 20px;"></td></tr> </table> <p><b>normal, interlocked with button "WEST"</b></p> <p><input type="radio"/> normal, not interlocked</p> <p><input type="radio"/> toggle (on/off)</p> </div>													<div style="border: 1px solid black; padding: 5px; width: 40px; margin: 0 auto; margin-bottom: 10px;">UP</div> <div style="border: 1px solid black; padding: 5px; width: 40px; margin: 0 auto; margin-bottom: 10px;">DOWN</div>	<div style="border: 1px solid black; padding: 5px; margin-bottom: 5px;"> <table border="1" style="width: 100%; height: 30px; border-collapse: collapse;"> <tr><td style="width: 25px; height: 20px;"></td><td style="width: 25px; height: 20px;"></td><td style="width: 25px; height: 20px;"></td><td style="width: 25px; height: 20px;"></td></tr> <tr><td style="width: 25px; height: 20px;"></td><td style="width: 25px; height: 20px;"></td><td style="width: 25px; height: 20px;"></td><td style="width: 25px; height: 20px;"></td></tr> <tr><td style="width: 25px; height: 20px;"></td><td style="width: 25px; height: 20px;"></td><td style="width: 25px; height: 20px;"></td><td style="width: 25px; height: 20px;"></td></tr> </table> <p><b>normal, interlocked with button "EAST"</b></p> <p><input type="radio"/> normal, not interlocked</p> <p><input type="radio"/> toggle (on/off)</p> </div>																
<div style="border: 1px solid black; padding: 5px; margin-bottom: 5px;"> <table border="1" style="width: 100%; height: 30px; border-collapse: collapse;"> <tr><td style="width: 25px; height: 20px;"></td><td style="width: 25px; height: 20px;"></td><td style="width: 25px; height: 20px;"></td><td style="width: 25px; height: 20px;"></td></tr> <tr><td style="width: 25px; height: 20px;"></td><td style="width: 25px; height: 20px;"></td><td style="width: 25px; height: 20px;"></td><td style="width: 25px; height: 20px;"></td></tr> <tr><td style="width: 25px; height: 20px;"></td><td style="width: 25px; height: 20px;"></td><td style="width: 25px; height: 20px;"></td><td style="width: 25px; height: 20px;"></td></tr> </table> <p><b>normal, interlocked with button "NORTH"</b></p> <p><input type="radio"/> normal, not interlocked</p> <p><input type="radio"/> toggle (on/off)</p> </div>													<div style="border: 1px solid black; padding: 5px; width: 40px; margin: 0 auto; margin-bottom: 10px;">EAST</div> <div style="border: 1px solid black; padding: 5px; width: 40px; margin: 0 auto; margin-bottom: 10px;">WEST</div>	<div style="border: 1px solid black; padding: 5px; margin-bottom: 5px;"> <table border="1" style="width: 100%; height: 30px; border-collapse: collapse;"> <tr><td style="width: 25px; height: 20px;"></td><td style="width: 25px; height: 20px;"></td><td style="width: 25px; height: 20px;"></td><td style="width: 25px; height: 20px;"></td></tr> <tr><td style="width: 25px; height: 20px;"></td><td style="width: 25px; height: 20px;"></td><td style="width: 25px; height: 20px;"></td><td style="width: 25px; height: 20px;"></td></tr> <tr><td style="width: 25px; height: 20px;"></td><td style="width: 25px; height: 20px;"></td><td style="width: 25px; height: 20px;"></td><td style="width: 25px; height: 20px;"></td></tr> </table> <p><b>normal, interlocked with button "SOUTH"</b></p> <p><input type="radio"/> normal, not interlocked</p> <p><input type="radio"/> toggle (on/off)</p> </div>																
<div style="border: 1px solid black; padding: 5px; margin-bottom: 5px;"> <table border="1" style="width: 100%; height: 30px; border-collapse: collapse;"> <tr><td style="width: 25px; height: 20px;"></td><td style="width: 25px; height: 20px;"></td><td style="width: 25px; height: 20px;"></td><td style="width: 25px; height: 20px;"></td></tr> <tr><td style="width: 25px; height: 20px;"></td><td style="width: 25px; height: 20px;"></td><td style="width: 25px; height: 20px;"></td><td style="width: 25px; height: 20px;"></td></tr> <tr><td style="width: 25px; height: 20px;"></td><td style="width: 25px; height: 20px;"></td><td style="width: 25px; height: 20px;"></td><td style="width: 25px; height: 20px;"></td></tr> </table> <p><b>normal, not interlocked</b></p> <p><input type="radio"/> normal, interlocked with button "2"</p> <p><input type="radio"/> toggle (on/off)</p> <p><input type="radio"/> on (off is button 2)</p> </div>													<div style="border: 1px solid black; padding: 5px; width: 40px; margin: 0 auto; margin-bottom: 10px;">SOUTH</div> <div style="border: 1px solid black; padding: 5px; width: 40px; margin: 0 auto; margin-bottom: 10px;">NORTH</div>	<div style="border: 1px solid black; padding: 5px; margin-bottom: 5px;"> <table border="1" style="width: 100%; height: 30px; border-collapse: collapse;"> <tr><td style="width: 25px; height: 20px;"></td><td style="width: 25px; height: 20px;"></td><td style="width: 25px; height: 20px;"></td><td style="width: 25px; height: 20px;"></td></tr> <tr><td style="width: 25px; height: 20px;"></td><td style="width: 25px; height: 20px;"></td><td style="width: 25px; height: 20px;"></td><td style="width: 25px; height: 20px;"></td></tr> <tr><td style="width: 25px; height: 20px;"></td><td style="width: 25px; height: 20px;"></td><td style="width: 25px; height: 20px;"></td><td style="width: 25px; height: 20px;"></td></tr> </table> <p><b>normal, not interlocked</b></p> <p><input type="radio"/> normal, interlocked with button "1"</p> <p><input type="radio"/> toggle (on/off)</p> <p><input type="radio"/> off (on is button "1")</p> </div>																
<div style="border: 1px solid black; padding: 5px; margin-bottom: 5px;"> <table border="1" style="width: 100%; height: 30px; border-collapse: collapse;"> <tr><td style="width: 25px; height: 20px;"></td><td style="width: 25px; height: 20px;"></td><td style="width: 25px; height: 20px;"></td><td style="width: 25px; height: 20px;"></td></tr> <tr><td style="width: 25px; height: 20px;"></td><td style="width: 25px; height: 20px;"></td><td style="width: 25px; height: 20px;"></td><td style="width: 25px; height: 20px;"></td></tr> <tr><td style="width: 25px; height: 20px;"></td><td style="width: 25px; height: 20px;"></td><td style="width: 25px; height: 20px;"></td><td style="width: 25px; height: 20px;"></td></tr> </table> <p><b>normal, not interlocked</b></p> <p><input type="radio"/> normal, interlocked with button "4"</p> <p><input type="radio"/> toggle (on/off)</p> <p><input type="radio"/> on (off is button "4")</p> </div>													<div style="border: 1px solid black; padding: 5px; width: 40px; margin: 0 auto; margin-bottom: 10px;">1</div> <div style="border: 1px solid black; padding: 5px; width: 40px; margin: 0 auto; margin-bottom: 10px;">2</div>	<div style="border: 1px solid black; padding: 5px; margin-bottom: 5px;"> <table border="1" style="width: 100%; height: 30px; border-collapse: collapse;"> <tr><td style="width: 25px; height: 20px;"></td><td style="width: 25px; height: 20px;"></td><td style="width: 25px; height: 20px;"></td><td style="width: 25px; height: 20px;"></td></tr> <tr><td style="width: 25px; height: 20px;"></td><td style="width: 25px; height: 20px;"></td><td style="width: 25px; height: 20px;"></td><td style="width: 25px; height: 20px;"></td></tr> <tr><td style="width: 25px; height: 20px;"></td><td style="width: 25px; height: 20px;"></td><td style="width: 25px; height: 20px;"></td><td style="width: 25px; height: 20px;"></td></tr> </table> <p><b>normal, not interlocked</b></p> <p><input type="radio"/> normal interlocked with button "3"</p> <p><input type="radio"/> toggle (on/off)</p> <p><input type="radio"/> off (on is button "3")</p> </div>																
<div style="border: 1px solid black; padding: 5px; margin-bottom: 5px;"> <table border="1" style="width: 100%; height: 30px; border-collapse: collapse;"> <tr><td style="width: 25px; height: 20px;"></td><td style="width: 25px; height: 20px;"></td><td style="width: 25px; height: 20px;"></td><td style="width: 25px; height: 20px;"></td></tr> <tr><td style="width: 25px; height: 20px;"></td><td style="width: 25px; height: 20px;"></td><td style="width: 25px; height: 20px;"></td><td style="width: 25px; height: 20px;"></td></tr> <tr><td style="width: 25px; height: 20px;"></td><td style="width: 25px; height: 20px;"></td><td style="width: 25px; height: 20px;"></td><td style="width: 25px; height: 20px;"></td></tr> </table> <p><b>normal, not interlocked</b></p> <p><input type="radio"/> toggle (on/off)</p> <p><input type="radio"/> inching .1 second</p> </div>													<div style="border: 1px solid black; padding: 5px; width: 40px; margin: 0 auto; margin-bottom: 10px;">3</div> <div style="border: 1px solid black; padding: 5px; width: 40px; margin: 0 auto; margin-bottom: 10px;">4</div>	<div style="border: 1px solid black; padding: 5px; margin-bottom: 5px;"> <table border="1" style="width: 100%; height: 30px; border-collapse: collapse;"> <tr><td style="width: 25px; height: 20px;"></td><td style="width: 25px; height: 20px;"></td><td style="width: 25px; height: 20px;"></td><td style="width: 25px; height: 20px;"></td></tr> <tr><td style="width: 25px; height: 20px;"></td><td style="width: 25px; height: 20px;"></td><td style="width: 25px; height: 20px;"></td><td style="width: 25px; height: 20px;"></td></tr> <tr><td style="width: 25px; height: 20px;"></td><td style="width: 25px; height: 20px;"></td><td style="width: 25px; height: 20px;"></td><td style="width: 25px; height: 20px;"></td></tr> </table> <p><b>normal, not interlocked</b></p> <p><input type="radio"/> toggle (on/off)</p> </div>																
<div style="border: 1px solid black; padding: 5px; margin-bottom: 5px;"> <table border="1" style="width: 100%; height: 30px; border-collapse: collapse;"> <tr><td style="width: 25px; height: 20px;"></td><td style="width: 25px; height: 20px;"></td><td style="width: 25px; height: 20px;"></td><td style="width: 25px; height: 20px;"></td></tr> <tr><td style="width: 25px; height: 20px;"></td><td style="width: 25px; height: 20px;"></td><td style="width: 25px; height: 20px;"></td><td style="width: 25px; height: 20px;"></td></tr> <tr><td style="width: 25px; height: 20px;"></td><td style="width: 25px; height: 20px;"></td><td style="width: 25px; height: 20px;"></td><td style="width: 25px; height: 20px;"></td></tr> </table> <p><b>normal, not interlocked</b></p> <p><input type="radio"/> toggle (on/off)</p> <p><input type="radio"/> inching .1 second</p> </div>													<div style="border: 1px solid black; padding: 5px; width: 40px; margin: 0 auto; margin-bottom: 10px;">5</div> <div style="border: 1px solid black; padding: 5px; width: 40px; margin: 0 auto; margin-bottom: 10px;">6</div>	<div style="border: 1px solid black; padding: 5px; margin-bottom: 5px;"> <table border="1" style="width: 100%; height: 30px; border-collapse: collapse;"> <tr><td style="width: 25px; height: 20px;"></td><td style="width: 25px; height: 20px;"></td><td style="width: 25px; height: 20px;"></td><td style="width: 25px; height: 20px;"></td></tr> <tr><td style="width: 25px; height: 20px;"></td><td style="width: 25px; height: 20px;"></td><td style="width: 25px; height: 20px;"></td><td style="width: 25px; height: 20px;"></td></tr> <tr><td style="width: 25px; height: 20px;"></td><td style="width: 25px; height: 20px;"></td><td style="width: 25px; height: 20px;"></td><td style="width: 25px; height: 20px;"></td></tr> </table> <p><b>normal, not interlocked</b></p> <p><input type="radio"/> toggle (on/off)</p> </div>																
<div style="border: 1px solid black; padding: 5px; margin-bottom: 5px;"> <table border="1" style="width: 100%; height: 30px; border-collapse: collapse;"> <tr><td style="width: 25px; height: 20px;"></td><td style="width: 25px; height: 20px;"></td><td style="width: 25px; height: 20px;"></td><td style="width: 25px; height: 20px;"></td></tr> <tr><td style="width: 25px; height: 20px;"></td><td style="width: 25px; height: 20px;"></td><td style="width: 25px; height: 20px;"></td><td style="width: 25px; height: 20px;"></td></tr> <tr><td style="width: 25px; height: 20px;"></td><td style="width: 25px; height: 20px;"></td><td style="width: 25px; height: 20px;"></td><td style="width: 25px; height: 20px;"></td></tr> </table> <p><b>normal, not interlocked</b></p> <p><input type="radio"/> toggle (on/off)</p> <p><input type="radio"/> inching .1 second</p> </div>													<p><b>Auto Shut Down time</b> <b>Default setting of 1 hour</b></p> <p><input type="radio"/> never</p> <p><input type="radio"/> 10 minutes</p> <p><input type="radio"/> 20 minutes</p> <p><input type="radio"/> 30 minutes</p> <p><input type="radio"/> 1 hour</p> <p><input type="radio"/> 2 hours</p> <p><input type="radio"/> 3 hours</p> <p><input type="radio"/> 4 hours</p>	<div style="border: 1px solid black; padding: 5px; margin-bottom: 5px;"> <table border="1" style="width: 100%; height: 30px; border-collapse: collapse;"> <tr><td style="width: 25px; height: 20px;"></td><td style="width: 25px; height: 20px;"></td><td style="width: 25px; height: 20px;"></td><td style="width: 25px; height: 20px;"></td></tr> <tr><td style="width: 25px; height: 20px;"></td><td style="width: 25px; height: 20px;"></td><td style="width: 25px; height: 20px;"></td><td style="width: 25px; height: 20px;"></td></tr> <tr><td style="width: 25px; height: 20px;"></td><td style="width: 25px; height: 20px;"></td><td style="width: 25px; height: 20px;"></td><td style="width: 25px; height: 20px;"></td></tr> </table> <p><b>normal, not interlocked</b></p> <p><input type="radio"/> toggle (on/off)</p> </div>																
<div style="border: 1px solid black; padding: 5px; margin-bottom: 5px;"> <table border="1" style="width: 100%; height: 30px; border-collapse: collapse;"> <tr><td style="width: 25px; height: 20px;"></td><td style="width: 25px; height: 20px;"></td><td style="width: 25px; height: 20px;"></td><td style="width: 25px; height: 20px;"></td></tr> <tr><td style="width: 25px; height: 20px;"></td><td style="width: 25px; height: 20px;"></td><td style="width: 25px; height: 20px;"></td><td style="width: 25px; height: 20px;"></td></tr> <tr><td style="width: 25px; height: 20px;"></td><td style="width: 25px; height: 20px;"></td><td style="width: 25px; height: 20px;"></td><td style="width: 25px; height: 20px;"></td></tr> </table> <p><b>normal, not interlocked</b></p> <p><input type="radio"/> toggle (on/off)</p> <p><input type="radio"/> inching .1 second</p> </div>													<p><input type="radio"/> inching .2 seconds</p> <p><input type="radio"/> inching .3 seconds</p> <p><input type="radio"/> inching .4 seconds</p> <p><input type="radio"/> inching .5 seconds</p>	<div style="border: 1px solid black; padding: 5px; margin-bottom: 5px;"> <table border="1" style="width: 100%; height: 30px; border-collapse: collapse;"> <tr><td style="width: 25px; height: 20px;"></td><td style="width: 25px; height: 20px;"></td><td style="width: 25px; height: 20px;"></td><td style="width: 25px; height: 20px;"></td></tr> <tr><td style="width: 25px; height: 20px;"></td><td style="width: 25px; height: 20px;"></td><td style="width: 25px; height: 20px;"></td><td style="width: 25px; height: 20px;"></td></tr> <tr><td style="width: 25px; height: 20px;"></td><td style="width: 25px; height: 20px;"></td><td style="width: 25px; height: 20px;"></td><td style="width: 25px; height: 20px;"></td></tr> </table> <p><b>normal, not interlocked</b></p> <p><input type="radio"/> toggle (on/off)</p> </div>																

## Technical Sheet: F22-2S1

### General Specifications

**Typical application:** 1 motion, 1 step, hoist.

**Operating Distance:** 500+feet

**Frequency:** 450Mhz band

**Number of available frequencies:** 256

**Frequency generation:** Synthesized phase lock loop.

**Security coding:** 4 billion unique security codes available.

**Environment rating:** Outdoor use, IP65

**Licensing:** FCC certified, no license needed.

**Warranty:** 1 year, see manual

**Temperature:** -35 to +75°C

### Receiver Specifications

**Size:** 10" x 6.5" x 4.5" not including antenna or cable

**Part #:** F22-6S-RX

**Power supply input:** 120VAC (240VAC and 12 or 24V, AC or DC available)

**Relay ratings:** 5amp/250VAC

**Error notification:** audible Morse Code via horn

**Weight:** 7 lbs.

**Includes:** Loud horn, large mainline indicator, emergency stop disconnect button. Totally precabled.

**Accessories available:** Extended antenna kit for mounting receiver inside cabinets or mounting antenna in better position for reception.

**Physical mounting specifications below**

### Transmitter Specifications

**Part #:** F22-2S1-TX

**Transmitters:** 2 supplied standard.

**Size:** W 2.4" x D 2.75" x L 8.5" (not including antenna)

**Weight:** 1 lb.

**Material:** shock resistant, fiber reinforced nylon

**Power source:** 4 AA alkaline batteries.

**Battery power indication:** LED and audible alarm.

**Buttons:** 2 programmable, 1 step, plus start and stop. See programming and custom labeling sheet. Rated to 2 million cycles

**Start key:** Removable

**Stop Button:** mushroom style

**Error notification:** audible Morse Code via buzzer

**Includes:** shoulder straps and 4 AA batteries.



### Receiver mounting

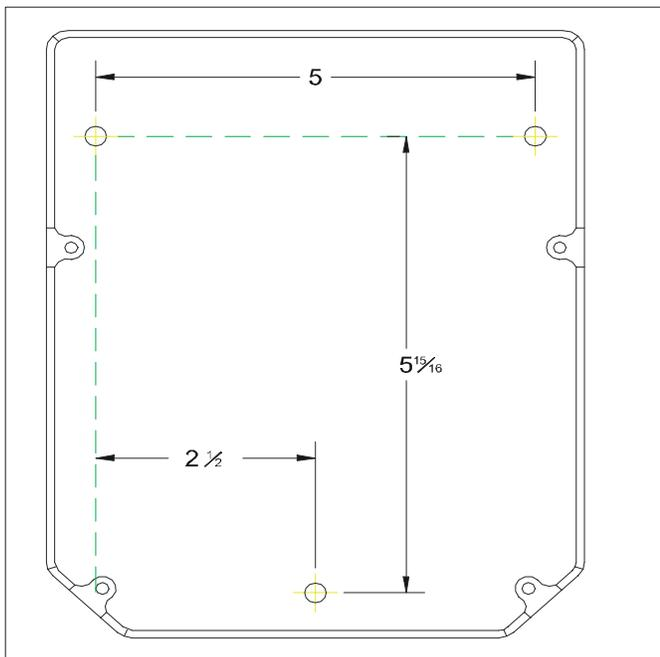

### Receiver schematic

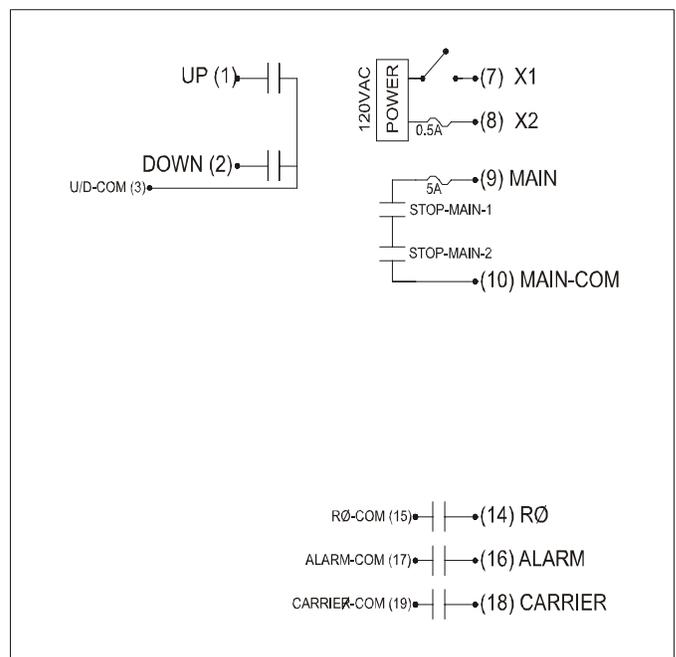

# Programming Sheet: F22-2S1

<p>PASSWORD</p> <table border="1"><tr><td> </td><td> </td><td> </td><td> </td></tr></table> <p>Default (no password)</p> <p><b>Auto Shut Down time</b> Default setting of 1 hour</p> <p><input type="radio"/> never <input type="radio"/> 10 minutes <input type="radio"/> 20 minutes <input type="radio"/> 30 minutes <input checked="" type="radio"/> <b>1 hour</b> <input type="radio"/> 2 hours <input type="radio"/> 3 hours <input type="radio"/> 4 hours</p>					<p>UP</p> <p>DOWN</p> <p><b>Second function of START position Sound Alarm</b></p> <p><input type="radio"/> Close RØ momentary <input type="radio"/> Close RØ toggle</p>	<table border="1"><tr><td> </td><td> </td><td> </td><td> </td><td> </td><td> </td></tr><tr><td> </td><td> </td><td> </td><td> </td><td> </td><td> </td></tr><tr><td> </td><td> </td><td> </td><td> </td><td> </td><td> </td></tr></table> <p><b>normal, interlocked with button "DOWN"</b></p> <p><input type="radio"/> normal, not interlocked <input type="radio"/> toggle (on/off)</p> <table border="1"><tr><td> </td><td> </td><td> </td><td> </td><td> </td><td> </td></tr><tr><td> </td><td> </td><td> </td><td> </td><td> </td><td> </td></tr><tr><td> </td><td> </td><td> </td><td> </td><td> </td><td> </td></tr></table> <p><b>normal, interlocked with button "UP"</b></p> <p><input type="radio"/> normal, not interlocked <input type="radio"/> toggle (on/off)</p>																																				



## Technical Sheet: F22-4S1

### General Specifications

**Typical application:** 2 motion, 1 step, monorail.

**Operating Distance:** 500+feet

**Frequency:** 450Mhz band  
**Number of available frequencies:** 256  
**Frequency generation:** Synthesized phase lock loop.

**Security coding:** 4 billion unique security codes available.

**Environment rating:** Outdoor use, IP65

**Licensing:** FCC certified, no license needed.

**Warranty:** 1 year, see manual

**Temperature Rating:** -35 to +75°C

### Receiver Specifications

**Size:** 10" x 6.5" x 4.5" not including antenna or cable  
**Part #:** F22-6S-RX

**Power supply input:** 120VAC (240VAC and 12 or 24V, AC or DC available)

**Relay ratings:** 5amp/250VAC  
**Error notification:** audible Morse Code via horn  
**Weight:** 7 lbs.

**Includes:** Loud horn, large mainline indicator, emergency stop disconnect button. Totally pre-cabled.

**Accessories available:** Extended antenna kit for mounting receiver inside cabinets or mounting antenna in better position for reception.

**Physical mounting specifications below**

### Transmitter Specifications

**Part #:** F22-4S1-TX

**Transmitters:** 2 supplied standard.

**Size:** W 2.4" x D 2.75" x L 8.5" (not including antenna)

**Weight:** 1 lb.

**Material:** shock resistant, fiber reinforced nylon

**Power source:** 4 AA alkaline batteries.

**Battery power indication:** LED and audible alarm.

**Buttons:** 4 programmable, 1 step, plus start and stop. See programming and custom labeling sheet. Rated to 2 million cycles

**Start key:** Removable

**Stop Button:** mushroom style

**Error notification:** audible Morse Code via buzzer

**Includes:** shoulder straps and 4 AA batteries.



### Receiver mounting

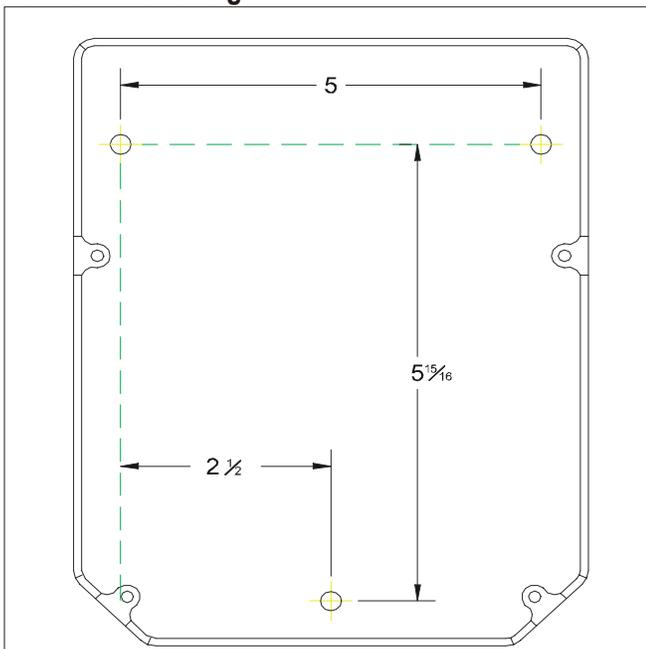

### Receiver schematic

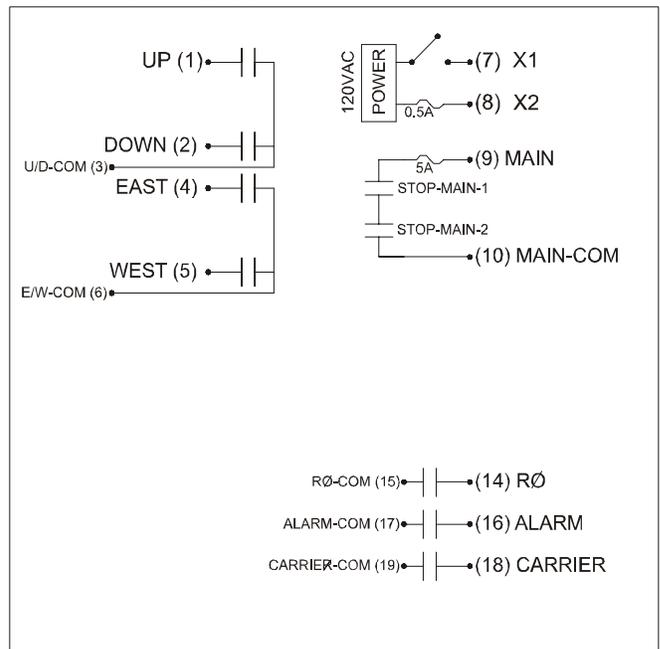

## Programming Sheet: F22-4S1

<p style="text-align: center;">PASSWORD</p> <table border="1" style="margin: auto; width: 80px; height: 20px;"> <tr> <td style="width: 20px; height: 20px;"></td> <td style="width: 20px; height: 20px;"></td> <td style="width: 20px; height: 20px;"></td> <td style="width: 20px; height: 20px;"></td> </tr> </table> <p style="text-align: center;">Default (no password)</p> <p><b>Auto Shut Down time</b> Default setting of 1 hour</p> <p> <input type="radio"/> never  <input type="radio"/> 10 minutes  <input type="radio"/> 20 minutes  <input type="radio"/> 30 minutes  <input checked="" type="radio"/> <b>1 hour</b>  <input type="radio"/> 2 hours  <input type="radio"/> 3 hours  <input type="radio"/> 4 hours         </p> <p><b>Second function of START position</b> <b>Sound Alarm</b></p> <p> <input type="radio"/> Close RØ momentary  <input type="radio"/> Close RØ toggle         </p>					<div style="border: 1px solid black; border-radius: 50%; width: 60px; height: 60px; margin: 10px auto; display: flex; align-items: center; justify-content: center;">UP</div> <div style="border: 1px solid black; border-radius: 50%; width: 60px; height: 60px; margin: 10px auto; display: flex; align-items: center; justify-content: center;">DOWN</div> <div style="border: 1px solid black; border-radius: 50%; width: 60px; height: 60px; margin: 10px auto; display: flex; align-items: center; justify-content: center;">EAST</div> <div style="border: 1px solid black; border-radius: 50%; width: 60px; height: 60px; margin: 10px auto; display: flex; align-items: center; justify-content: center;">WEST</div>	<table border="1" style="width: 100%; border-collapse: collapse;"> <tr> <td style="padding: 5px;"> <table border="1" style="width: 100%; border-collapse: collapse;"> <tr><td style="width: 20px; height: 20px;"></td><td style="width: 20px; height: 20px;"></td><td style="width: 20px; height: 20px;"></td><td style="width: 20px; height: 20px;"></td><td style="width: 20px; height: 20px;"></td><td style="width: 20px; height: 20px;"></td></tr> <tr><td style="width: 20px; height: 20px;"></td><td style="width: 20px; height: 20px;"></td><td style="width: 20px; height: 20px;"></td><td style="width: 20px; height: 20px;"></td><td style="width: 20px; height: 20px;"></td><td style="width: 20px; height: 20px;"></td><td style="width: 20px; height: 20px;"></td></tr> <tr><td style="width: 20px; height: 20px;"></td><td style="width: 20px; height: 20px;"></td><td style="width: 20px; height: 20px;"></td><td style="width: 20px; height: 20px;"></td><td style="width: 20px; height: 20px;"></td><td style="width: 20px; height: 20px;"></td></tr> </table> <p><b>normal, interlocked with button "DOWN"</b></p> <p> <input type="radio"/> normal, not interlocked  <input type="radio"/> toggle (on/off)         </p> </td> </tr> <tr> <td style="padding: 5px;"> <table border="1" style="width: 100%; border-collapse: collapse;"> <tr><td style="width: 20px; height: 20px;"></td><td style="width: 20px; height: 20px;"></td><td style="width: 20px; height: 20px;"></td><td style="width: 20px; height: 20px;"></td><td style="width: 20px; height: 20px;"></td><td style="width: 20px; height: 20px;"></td></tr> <tr><td style="width: 20px; height: 20px;"></td><td style="width: 20px; height: 20px;"></td><td style="width: 20px; height: 20px;"></td><td style="width: 20px; height: 20px;"></td><td style="width: 20px; height: 20px;"></td><td style="width: 20px; height: 20px;"></td><td style="width: 20px; height: 20px;"></td></tr> <tr><td style="width: 20px; height: 20px;"></td><td style="width: 20px; height: 20px;"></td><td style="width: 20px; height: 20px;"></td><td style="width: 20px; height: 20px;"></td><td style="width: 20px; height: 20px;"></td><td style="width: 20px; height: 20px;"></td></tr> </table> <p><b>normal, interlocked with button "UP"</b></p> <p> <input type="radio"/> normal, not interlocked  <input type="radio"/> toggle (on/off)         </p> </td> </tr> <tr> <td style="padding: 5px;"> <table border="1" style="width: 100%; border-collapse: collapse;"> <tr><td style="width: 20px; height: 20px;"></td><td style="width: 20px; height: 20px;"></td><td style="width: 20px; height: 20px;"></td><td style="width: 20px; height: 20px;"></td><td style="width: 20px; height: 20px;"></td><td style="width: 20px; height: 20px;"></td></tr> <tr><td style="width: 20px; height: 20px;"></td><td style="width: 20px; height: 20px;"></td><td style="width: 20px; height: 20px;"></td><td style="width: 20px; height: 20px;"></td><td style="width: 20px; height: 20px;"></td><td style="width: 20px; height: 20px;"></td><td style="width: 20px; height: 20px;"></td></tr> <tr><td style="width: 20px; height: 20px;"></td><td style="width: 20px; height: 20px;"></td><td style="width: 20px; height: 20px;"></td><td style="width: 20px; height: 20px;"></td><td style="width: 20px; height: 20px;"></td><td style="width: 20px; height: 20px;"></td></tr> </table> <p><b>normal, interlocked with button "WEST"</b></p> <p> <input type="radio"/> normal, not interlocked  <input type="radio"/> toggle (on/off)         </p> </td> </tr> <tr> <td style="padding: 5px;"> <table border="1" style="width: 100%; border-collapse: collapse;"> <tr><td style="width: 20px; height: 20px;"></td><td style="width: 20px; height: 20px;"></td><td style="width: 20px; height: 20px;"></td><td style="width: 20px; height: 20px;"></td><td style="width: 20px; height: 20px;"></td><td style="width: 20px; height: 20px;"></td></tr> <tr><td style="width: 20px; height: 20px;"></td><td style="width: 20px; height: 20px;"></td><td style="width: 20px; height: 20px;"></td><td style="width: 20px; height: 20px;"></td><td style="width: 20px; height: 20px;"></td><td style="width: 20px; height: 20px;"></td><td style="width: 20px; height: 20px;"></td></tr> <tr><td style="width: 20px; height: 20px;"></td><td style="width: 20px; height: 20px;"></td><td style="width: 20px; height: 20px;"></td><td style="width: 20px; height: 20px;"></td><td style="width: 20px; height: 20px;"></td><td style="width: 20px; height: 20px;"></td></tr> </table> <p><b>normal, interlocked with button "EAST"</b></p> <p> <input type="radio"/> normal, not interlocked  <input type="radio"/> toggle (on/off)         </p> </td> </tr> </table>	<table border="1" style="width: 100%; border-collapse: collapse;"> <tr><td style="width: 20px; height: 20px;"></td><td style="width: 20px; height: 20px;"></td><td style="width: 20px; height: 20px;"></td><td style="width: 20px; height: 20px;"></td><td style="width: 20px; height: 20px;"></td><td style="width: 20px; height: 20px;"></td></tr> <tr><td style="width: 20px; height: 20px;"></td><td style="width: 20px; height: 20px;"></td><td style="width: 20px; height: 20px;"></td><td style="width: 20px; height: 20px;"></td><td style="width: 20px; height: 20px;"></td><td style="width: 20px; height: 20px;"></td><td style="width: 20px; height: 20px;"></td></tr> <tr><td style="width: 20px; height: 20px;"></td><td style="width: 20px; height: 20px;"></td><td style="width: 20px; height: 20px;"></td><td style="width: 20px; height: 20px;"></td><td style="width: 20px; height: 20px;"></td><td style="width: 20px; height: 20px;"></td></tr> </table> <p><b>normal, interlocked with button "DOWN"</b></p> <p> <input type="radio"/> normal, not interlocked  <input type="radio"/> toggle (on/off)         </p>																				<table border="1" style="width: 100%; border-collapse: collapse;"> <tr><td style="width: 20px; height: 20px;"></td><td style="width: 20px; height: 20px;"></td><td style="width: 20px; height: 20px;"></td><td style="width: 20px; height: 20px;"></td><td style="width: 20px; height: 20px;"></td><td style="width: 20px; height: 20px;"></td></tr> <tr><td style="width: 20px; height: 20px;"></td><td style="width: 20px; height: 20px;"></td><td style="width: 20px; height: 20px;"></td><td style="width: 20px; height: 20px;"></td><td style="width: 20px; height: 20px;"></td><td style="width: 20px; height: 20px;"></td><td style="width: 20px; height: 20px;"></td></tr> <tr><td style="width: 20px; height: 20px;"></td><td style="width: 20px; height: 20px;"></td><td style="width: 20px; height: 20px;"></td><td style="width: 20px; height: 20px;"></td><td style="width: 20px; height: 20px;"></td><td style="width: 20px; height: 20px;"></td></tr> </table> <p><b>normal, interlocked with button "UP"</b></p> <p> <input type="radio"/> normal, not interlocked  <input type="radio"/> toggle (on/off)         </p>																				<table border="1" style="width: 100%; border-collapse: collapse;"> <tr><td style="width: 20px; height: 20px;"></td><td style="width: 20px; height: 20px;"></td><td style="width: 20px; height: 20px;"></td><td style="width: 20px; height: 20px;"></td><td style="width: 20px; height: 20px;"></td><td style="width: 20px; height: 20px;"></td></tr> <tr><td style="width: 20px; height: 20px;"></td><td style="width: 20px; height: 20px;"></td><td style="width: 20px; height: 20px;"></td><td style="width: 20px; height: 20px;"></td><td style="width: 20px; height: 20px;"></td><td style="width: 20px; height: 20px;"></td><td style="width: 20px; height: 20px;"></td></tr> <tr><td style="width: 20px; height: 20px;"></td><td style="width: 20px; height: 20px;"></td><td style="width: 20px; height: 20px;"></td><td style="width: 20px; height: 20px;"></td><td style="width: 20px; height: 20px;"></td><td style="width: 20px; height: 20px;"></td></tr> </table> <p><b>normal, interlocked with button "WEST"</b></p> <p> <input type="radio"/> normal, not interlocked  <input type="radio"/> toggle (on/off)         </p>																				<table border="1" style="width: 100%; border-collapse: collapse;"> <tr><td style="width: 20px; height: 20px;"></td><td style="width: 20px; height: 20px;"></td><td style="width: 20px; height: 20px;"></td><td style="width: 20px; height: 20px;"></td><td style="width: 20px; height: 20px;"></td><td style="width: 20px; height: 20px;"></td></tr> <tr><td style="width: 20px; height: 20px;"></td><td style="width: 20px; height: 20px;"></td><td style="width: 20px; height: 20px;"></td><td style="width: 20px; height: 20px;"></td><td style="width: 20px; height: 20px;"></td><td style="width: 20px; height: 20px;"></td><td style="width: 20px; height: 20px;"></td></tr> <tr><td style="width: 20px; height: 20px;"></td><td style="width: 20px; height: 20px;"></td><td style="width: 20px; height: 20px;"></td><td style="width: 20px; height: 20px;"></td><td style="width: 20px; height: 20px;"></td><td style="width: 20px; height: 20px;"></td></tr> </table> <p><b>normal, interlocked with button "EAST"</b></p> <p> <input type="radio"/> normal, not interlocked  <input type="radio"/> toggle (on/off)         </p>																			
<table border="1" style="width: 100%; border-collapse: collapse;"> <tr><td style="width: 20px; height: 20px;"></td><td style="width: 20px; height: 20px;"></td><td style="width: 20px; height: 20px;"></td><td style="width: 20px; height: 20px;"></td><td style="width: 20px; height: 20px;"></td><td style="width: 20px; height: 20px;"></td></tr> <tr><td style="width: 20px; height: 20px;"></td><td style="width: 20px; height: 20px;"></td><td style="width: 20px; height: 20px;"></td><td style="width: 20px; height: 20px;"></td><td style="width: 20px; height: 20px;"></td><td style="width: 20px; height: 20px;"></td><td style="width: 20px; height: 20px;"></td></tr> <tr><td style="width: 20px; height: 20px;"></td><td style="width: 20px; height: 20px;"></td><td style="width: 20px; height: 20px;"></td><td style="width: 20px; height: 20px;"></td><td style="width: 20px; height: 20px;"></td><td style="width: 20px; height: 20px;"></td></tr> </table> <p><b>normal, interlocked with button "DOWN"</b></p> <p> <input type="radio"/> normal, not interlocked  <input type="radio"/> toggle (on/off)         </p>																																																																																						
<table border="1" style="width: 100%; border-collapse: collapse;"> <tr><td style="width: 20px; height: 20px;"></td><td style="width: 20px; height: 20px;"></td><td style="width: 20px; height: 20px;"></td><td style="width: 20px; height: 20px;"></td><td style="width: 20px; height: 20px;"></td><td style="width: 20px; height: 20px;"></td></tr> <tr><td style="width: 20px; height: 20px;"></td><td style="width: 20px; height: 20px;"></td><td style="width: 20px; height: 20px;"></td><td style="width: 20px; height: 20px;"></td><td style="width: 20px; height: 20px;"></td><td style="width: 20px; height: 20px;"></td><td style="width: 20px; height: 20px;"></td></tr> <tr><td style="width: 20px; height: 20px;"></td><td style="width: 20px; height: 20px;"></td><td style="width: 20px; height: 20px;"></td><td style="width: 20px; height: 20px;"></td><td style="width: 20px; height: 20px;"></td><td style="width: 20px; height: 20px;"></td></tr> </table> <p><b>normal, interlocked with button "UP"</b></p> <p> <input type="radio"/> normal, not interlocked  <input type="radio"/> toggle (on/off)         </p>																																																																																						
<table border="1" style="width: 100%; border-collapse: collapse;"> <tr><td style="width: 20px; height: 20px;"></td><td style="width: 20px; height: 20px;"></td><td style="width: 20px; height: 20px;"></td><td style="width: 20px; height: 20px;"></td><td style="width: 20px; height: 20px;"></td><td style="width: 20px; height: 20px;"></td></tr> <tr><td style="width: 20px; height: 20px;"></td><td style="width: 20px; height: 20px;"></td><td style="width: 20px; height: 20px;"></td><td style="width: 20px; height: 20px;"></td><td style="width: 20px; height: 20px;"></td><td style="width: 20px; height: 20px;"></td><td style="width: 20px; height: 20px;"></td></tr> <tr><td style="width: 20px; height: 20px;"></td><td style="width: 20px; height: 20px;"></td><td style="width: 20px; height: 20px;"></td><td style="width: 20px; height: 20px;"></td><td style="width: 20px; height: 20px;"></td><td style="width: 20px; height: 20px;"></td></tr> </table> <p><b>normal, interlocked with button "WEST"</b></p> <p> <input type="radio"/> normal, not interlocked  <input type="radio"/> toggle (on/off)         </p>																																																																																						
<table border="1" style="width: 100%; border-collapse: collapse;"> <tr><td style="width: 20px; height: 20px;"></td><td style="width: 20px; height: 20px;"></td><td style="width: 20px; height: 20px;"></td><td style="width: 20px; height: 20px;"></td><td style="width: 20px; height: 20px;"></td><td style="width: 20px; height: 20px;"></td></tr> <tr><td style="width: 20px; height: 20px;"></td><td style="width: 20px; height: 20px;"></td><td style="width: 20px; height: 20px;"></td><td style="width: 20px; height: 20px;"></td><td style="width: 20px; height: 20px;"></td><td style="width: 20px; height: 20px;"></td><td style="width: 20px; height: 20px;"></td></tr> <tr><td style="width: 20px; height: 20px;"></td><td style="width: 20px; height: 20px;"></td><td style="width: 20px; height: 20px;"></td><td style="width: 20px; height: 20px;"></td><td style="width: 20px; height: 20px;"></td><td style="width: 20px; height: 20px;"></td></tr> </table> <p><b>normal, interlocked with button "EAST"</b></p> <p> <input type="radio"/> normal, not interlocked  <input type="radio"/> toggle (on/off)         </p>																																																																																						

# Technical Sheet: F22-6S1

## General Specifications

**Typical application:** 3 motion, 1 step, overhead crane.  
**Operating Distance:** 500+feet

**Frequency:** 450Mhz band  
**Number of available frequencies:** 256

**Frequency generation:** Synthesized phase lock loop.  
**Security coding:** 4 billion unique security codes available.  
**Environment rating:** Outdoor use, IP65

**Licensing:** FCC certified, no license needed.  
**Warranty:** 1 year, see manual

**Temperature Rating:** -35 to +75°C

### Receiver mounting

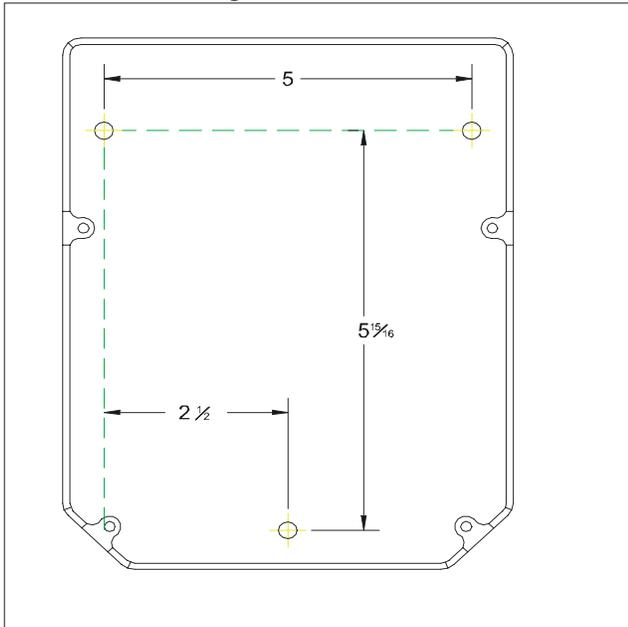

## Receiver Specifications

**Size:** 10" x 6.5" x 4.5" not including antenna or cable  
**Part #:** F22-6S-RX  
**Power supply input:** 120VAC (240VAC and 12 or 24V, AC or DC available)

**Relay ratings:** 5amp/250VAC  
**Error notification:** audible Morse Code via horn  
**Weight:** 7 lbs.  
**Includes:** Loud horn, large mainline indicator, emergency stop disconnect button. Totally pre-cabled.

**Accessories available:** Extended antenna kit for mounting receiver inside cabinets or mounting antenna in better position for reception.

**Physical mounting specifications below**

## Transmitter Specifications

**Part #:** F22-6S1-TX  
**Transmitters:** 2 supplied standard.  
**Size:** W 2.4" x D 2.75" x L 8.5" (not including antenna)  
**Weight:** 1 lb.  
**Material:** shock resistant, fiber reinforced nylon  
**Power source:** 4 AA alkaline batteries.  
**Battery power indication:** LED and audible alarm.  
**Buttons:** 6 programmable, 1 step, plus start and stop. See programming and custom labeling sheet. Rated to 2 million cycles  
**Start key:** Removable  
**Stop Button:** mushroom style  
**Error notification:** audible Morse Code via buzzer  
**Includes:** shoulder straps and 4 AA batteries.



### Receiver schematic

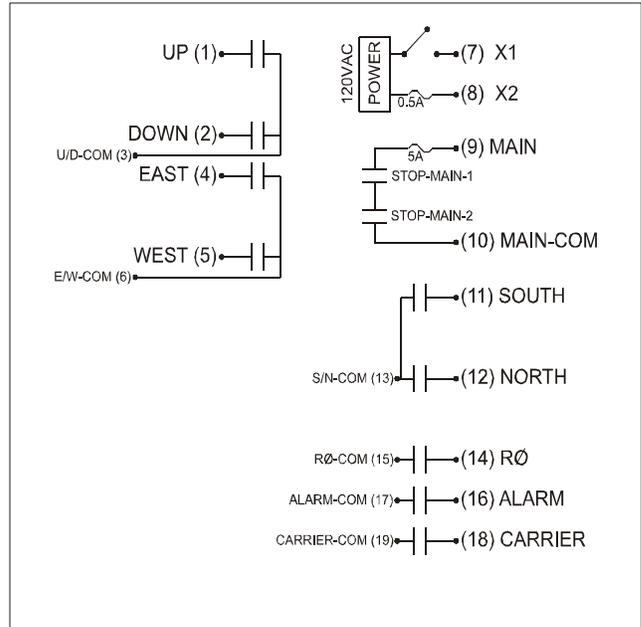

## Programming Sheet: F22-6S1

PASSWORD

--	--	--	--

**Default (no password)**  
Note: South and North may not be used in a password.

**Auto Shut Down time**  
Default setting of 1 hour

never

10 minutes

20 minutes

30 minutes

**1 hour**

2 hours

3 hours

4 hours

**Second function of START position**  
**Sound Alarm**

Close RØ momentary

Close RØ toggle

UP

DOWN

EAST

WEST

SOUTH

NORTH

**normal, interlocked with button "DOWN"**

normal, not interlocked

toggle (on/off)

**normal, interlocked with button "UP"**

normal, not interlocked

toggle (on/off)

**normal, interlocked with button "WEST"**

normal, not interlocked

toggle (on/off)

**normal, interlocked with button "EAST"**

normal, not interlocked

toggle (on/off)

**normal, interlocked with button "NORTH"**

normal, not interlocked

toggle (on/off)

**normal, interlocked with button "SOUTH"**

normal, not interlocked

toggle (on/off)

## Technical Sheet: F22-10S1

### General Specifications

**Typical application:** Up to 5 motions, 1 step, overhead crane. Also A, B, A+B applications. Works great with variable frequency drives.

**Operating Distance:** 500+feet

**Frequency:** 450Mhz band

**Number of available frequencies:** 256

**Frequency generation:** Synthesized phase lock loop.

**Security coding:** 4 billion unique security codes available.

**Environment rating:** Outdoor use, IP65

**Licensing:** FCC certified, no license needed.

**Warranty:** 1 year, see manual

**Temperature Rating:** -35 to +75°C

### Receiver mounting

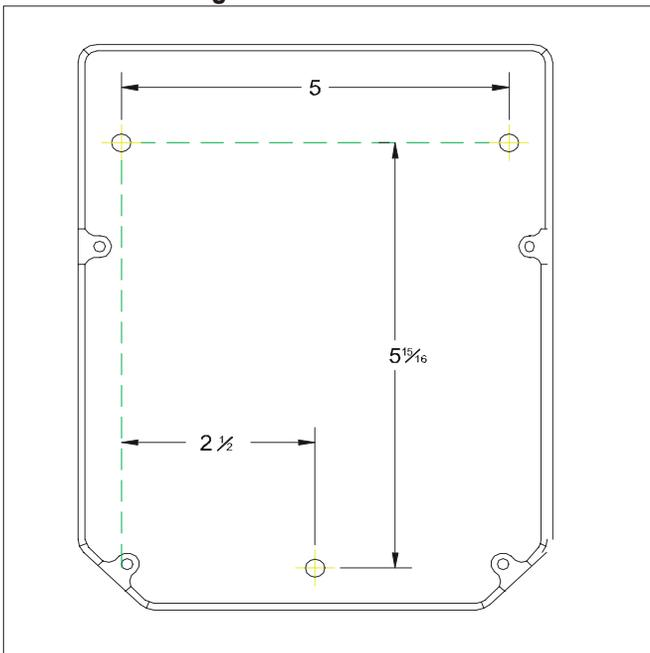

### Receiver Specifications

**Size:** 10" x 6.5" x 4.5", not including antenna or cable

**Part #:** F22-12S-RX

**Power supply input:** 120VAC (240VAC and 12 or 24V, AC or DC available)

**Relay ratings:** 5amp/250VAC

**Error notification:** audible Morse Code via horn

**Weight:** 7 lbs.

**Includes:** Loud horn, large mainline indicator, emergency stop disconnect button. Totally pre-cabled.

**Accessories available:** Extended antenna kit for mounting receiver inside cabinets or mounting antenna in better position for reception.

**Physical mounting specifications below**

### Transmitter Specifications

**Part #:** F22-10S1-TX

**Transmitters:** 2 supplied standard.

**Size:** W 2.4" x D 2.75" x L 8.5" (not including antenna)

**Weight:** 1 lb.

**Material:** shock resistant, fiber reinforced nylon

**Power source:** 4 AA alkaline batteries.

**Battery power indication:** LED and audible alarm.

**Buttons:** 10 programmable, 1 step, plus start and stop. See programming and custom labeling sheet. Rated to 2 million cycles

**Start key:** Removable

**Stop Button:** mushroom style

**Error notification:** audible Morse Code via buzzer

**Includes:** shoulder straps and 4 AA batteries.



### Receiver schematic

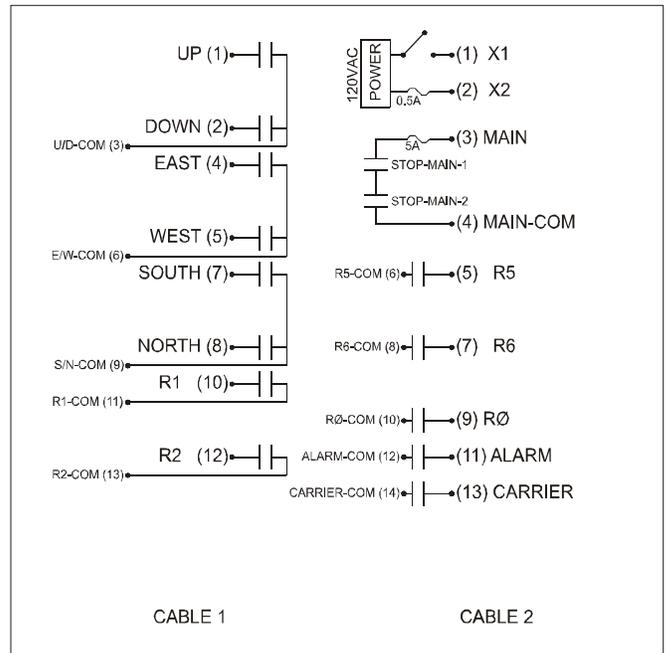

## Programming Sheet: F22-10S1

**Second function of START position  
Sound Alarm**

Close RØ momentary  
 Close RØ toggle

PASSWORD

--	--	--	--

**Default (no password)**  
Note: 5 and 6 may not be Used in a password.

**normal, interlocked with button "DOWN"**

normal, not interlocked  
 toggle (on/off)

**1**

**2**

**5**

**6**

UP

DOWN

EAST

WEST

SOUTH

NORTH

**normal, interlocked with button "UP"**

normal, not interlocked  
 toggle (on/off)

**normal, not interlocked**

normal, interlocked with button "1"  
 toggle (on/off)  
 off (on is button "1")

**2**

**normal, interlocked with button "WEST"**

normal, not interlocked  
 toggle (on/off)

**normal, not interlocked**

toggle (on/off)  
 inching .1 second  
 inching .2 seconds  
 inching .3 seconds  
 inching .4 seconds  
 inching .5 seconds

**6**

**normal, interlocked with button "EAST"**

normal, not interlocked  
 toggle (on/off)

**normal, not interlocked**

toggle (on/off)

**Auto Shut Down time  
Default setting of 1 hour**

never  
 10 minutes  
 20 minutes  
 30 minutes  
**1 hour**  
 2 hours  
 3 hours  
 4 hours

**normal, interlocked with button "NORTH"**

normal, not interlocked  
 toggle (on/off)

**normal, not interlocked**

toggle (on/off)

**6**

**normal, interlocked with button "SOUTH"**

normal, not interlocked  
 toggle (on/off)

## Technical Sheet: F22-2D

### General Specifications

**Typical application:** 1 motion, 2 step, hoist. Works great with variable frequency drives.

**Operating Distance:** 500+feet

**Frequency:** 450Mhz band

**Number of available frequencies:** 256

**Frequency generation:** Synthesized phase lock loop.

**Security coding:** 4 billion unique security codes available.

**Environment rating:** Outdoor use, IP65

**Licensing:** FCC certified, no license needed.

**Warranty:** 1 year, see manual

**Temperature Rating:** -35 to +75°C

### Receiver Specifications

**Size:** 10" x 6.5" x 4.5", not including antenna or cable

**Part #:** F22-6D-RX

**Power supply input:** 120VAC (240VAC and 12 or 24V, AC or DC available)

**Relay ratings:** 5amp/250VAC

**Error notification:** audible Morse Code via horn

**Weight:** 7 lbs.

**Includes:** Loud horn, large mainline indicator, emergency stop disconnect button. Totally precabled.

**Accessories available:**

Extended antenna kit for mounting receiver inside cabinets or mounting antenna in better position for reception.

**Physical mounting specifications below**

### Transmitter Specifications

**Part #:** F22-2D-TX

**Transmitters:** 2 supplied standard.

**Size:** W 2.5" x D 2.5" x L 6.5" (not including antenna)

**Weight:** less than 1 lb.

**Material:** shock resistant, fiber reinforced nylon

**Power source:** 4 AA alkaline batteries.

**Battery power indication:** LED and audible alarm.

**Buttons:** 2 programmable, 2 step, plus start and stop. See programming and custom labeling sheet. Rated to 2 million cycles

**Start key:** Removable

**Stop Button:** mushroom style

**Error notification:** audible Morse Code via buzzer

**Includes:** shoulder straps and 4 AA batteries.



**Receiver mounting**

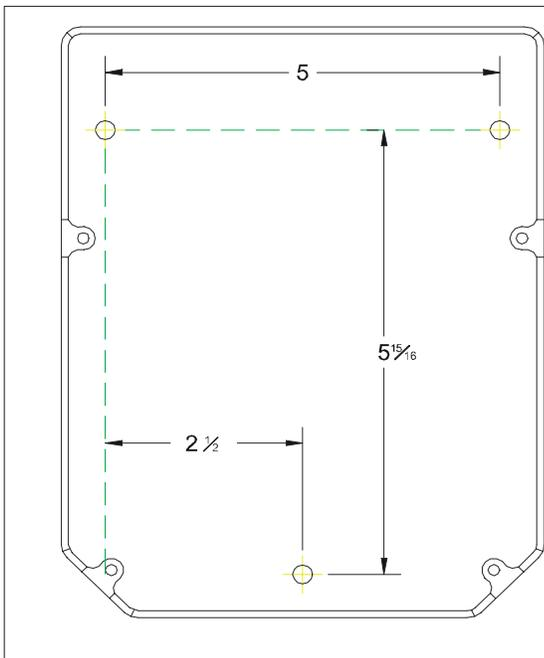

**Receiver schematic**

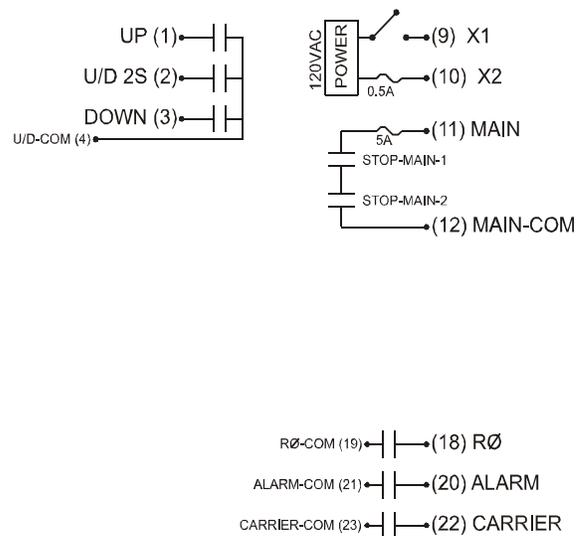

## Programming Sheet: F22-2D

<div style="border: 1px solid black; padding: 5px; margin-bottom: 10px;"> <table border="1" style="width: 100%; height: 30px; border-collapse: collapse;"> <tr><td style="width: 25px; height: 20px;"></td><td style="width: 25px; height: 20px;"></td><td style="width: 25px; height: 20px;"></td><td style="width: 25px; height: 20px;"></td></tr> </table> <table border="1" style="width: 100%; height: 30px; border-collapse: collapse;"> <tr><td style="width: 25px; height: 20px;"></td><td style="width: 25px; height: 20px;"></td><td style="width: 25px; height: 20px;"></td><td style="width: 25px; height: 20px;"></td></tr> </table> <table border="1" style="width: 100%; height: 30px; border-collapse: collapse;"> <tr><td style="width: 25px; height: 20px;"></td><td style="width: 25px; height: 20px;"></td><td style="width: 25px; height: 20px;"></td><td style="width: 25px; height: 20px;"></td></tr> </table> <p><b>normal, interlocked with button "DOWN"</b></p> <p><input type="radio"/> normal, not interlocked</p> <p><input type="radio"/> toggle (on/off)</p> </div> <p><b>Second function of START position</b></p> <p><b>Sound Alarm</b></p> <p><input type="radio"/> Close RØ momentary</p> <p><input type="radio"/> Close RØ toggle</p>													<p><b>Acceleration delay for all button relays.</b></p> <p><b>Default setting of ZERO</b></p> <p><input type="radio"/> .3 seconds    <input type="radio"/> 2 seconds</p> <p><input type="radio"/> 1 second    <input type="radio"/> 3 seconds</p> <p><input type="radio"/> 1.5 seconds    <input type="radio"/> 4 seconds</p> <p style="text-align: center;">PASSWORD</p> <table border="1" style="width: 100%; height: 20px; border-collapse: collapse;"> <tr><td style="width: 25px; height: 15px;"></td><td style="width: 25px; height: 15px;"></td><td style="width: 25px; height: 15px;"></td><td style="width: 25px; height: 15px;"></td></tr> </table> <p style="text-align: center;"><b>Default (no password)</b></p> <div style="display: flex; justify-content: space-around; align-items: center;"> <div style="border: 1px solid black; padding: 10px; width: 40px; text-align: center;">UP</div> <div style="border: 1px solid black; padding: 10px; width: 40px; text-align: center;">DOWN</div> </div> <p><b>Auto Shut Down time</b></p> <p><b>Default setting of 1 hour</b></p> <p><input type="radio"/> never</p> <p><input type="radio"/> 10 minutes</p> <p><input type="radio"/> 20 minutes</p> <p><input type="radio"/> 30 minutes</p> <p><b>1 hour</b></p> <p><input type="radio"/> 2 hours</p> <p><input type="radio"/> 3 hours</p> <p><input type="radio"/> 4 hours</p>					<div style="border: 1px solid black; padding: 5px; margin-bottom: 10px;"> <table border="1" style="width: 100%; height: 30px; border-collapse: collapse;"> <tr><td style="width: 25px; height: 20px;"></td><td style="width: 25px; height: 20px;"></td><td style="width: 25px; height: 20px;"></td><td style="width: 25px; height: 20px;"></td></tr> </table> <table border="1" style="width: 100%; height: 30px; border-collapse: collapse;"> <tr><td style="width: 25px; height: 20px;"></td><td style="width: 25px; height: 20px;"></td><td style="width: 25px; height: 20px;"></td><td style="width: 25px; height: 20px;"></td></tr> </table> <table border="1" style="width: 100%; height: 30px; border-collapse: collapse;"> <tr><td style="width: 25px; height: 20px;"></td><td style="width: 25px; height: 20px;"></td><td style="width: 25px; height: 20px;"></td><td style="width: 25px; height: 20px;"></td></tr> </table> <p><b>normal, interlocked with button "UP"</b></p> <p><input type="radio"/> normal, not interlocked</p> <p><input type="radio"/> toggle (on/off)</p> </div>												



## Technical Sheet: F22-4D

### General Specifications

**Typical application:** 2 motion, 2 step, monorail. Works great with variable frequency drives.

**Operating Distance:** 500+feet

**Frequency:** 450Mhz band

**Number of available frequencies:** 256

**Frequency generation:** Synthesized phase lock loop.

**Security coding:** 4 billion unique security codes available.

**Environment rating:** Outdoor use, IP65

**Licensing:** FCC certified, no license needed.

**Warranty:** 1 year, see manual

**Temperature Rating:** -35 to +75°C

### Receiver Specifications

**Size:** 10" x 6.5" x 4.5", not including antenna or cable

**Part #:** F22-6D-RX

**Power supply input:** 120VAC (240VAC and 12 or 24V, AC or DC available)

**Relay ratings:** 5amp/250VAC

**Error notification:** audible Morse Code via horn

**Weight:** 7 lbs.

**Includes:** Loud horn, large mainline indicator, emergency stop disconnect button. Totally pre-cabled.

**Accessories available:** Extended antenna kit for mounting receiver inside cabinets or mounting antenna in better position for reception.

**Physical mounting specifications below**

### Transmitter Specifications

**Part #:** F22-4D-TX

**Transmitters:** 2 supplied standard.

**Size:** W 2.5" x D 2.5" x L 6.5" (not including antenna)

**Weight:** less than 1 lb.

**Material:** shock resistant, fiber reinforced nylon

**Power source:** 4 AA alkaline batteries.

**Battery power indication:** LED and audible alarm.

**Buttons:** 4 programmable, 2 step, plus start and stop. See programming and custom labeling sheet. Rated to 2 million cycles

**Start key:** Removable

**Stop Button:** mushroom style

**Error notification:** audible Morse Code via buzzer

**Includes:** shoulder straps and 4 AA batteries.



#### Receiver mounting

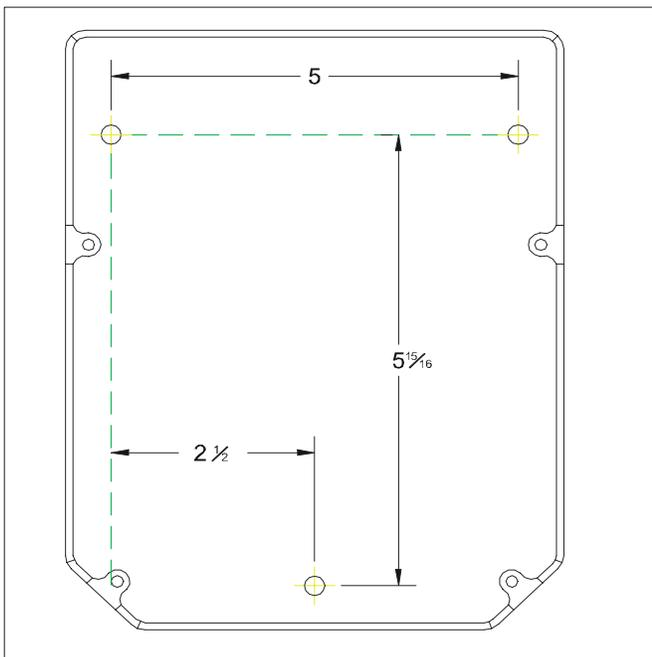

#### Receiver schematic

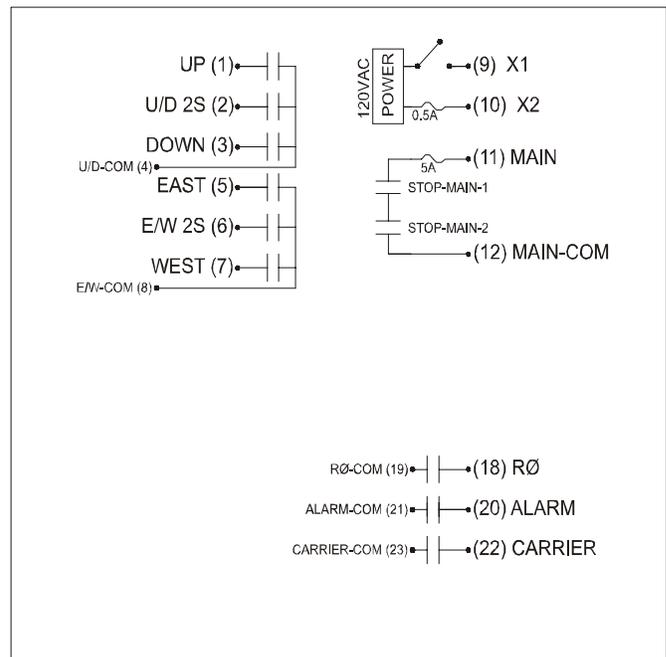

## Programming Sheet: F22-4D

**Acceleration delay for all button relays.**  
**Default setting of ZERO**

.3 seconds     2 seconds  
 1 second     3 seconds  
 1.5 seconds     4 seconds

**normal, interlocked with button "DOWN"**

normal, not interlocked  
 toggle (on/off)  
 on (off is button "DOWN")

**normal, interlocked with button "WEST"**

normal, not interlocked  
 toggle (on/off)  
 on (off is button "WEST")

**PASSWORD**

--	--	--	--	--

**Default (no password)**

UP

DOWN

EAST

WEST

**normal, interlocked with button "UP"**

normal, not interlocked  
 toggle (on/off)  
 off (on is button "UP")

**normal, interlocked with button "EAST"**

normal, not interlocked  
 toggle (on/off)  
 off (on is button "EAST")

**Second function of START position Sound Alarm**

Close RØ momentary  
 Close RØ toggle

**Auto Shut Down time**  
**Default setting of 1 hour**

never  
 10 minutes  
 20 minutes  
 30 minutes  
 **1 hour**  
 2 hours  
 3 hours  
 4 hours

## Technical Sheet: F22-6D

### General Specifications

**Typical application:** 3 motion, 2 step, overhead crane. Works great with variable frequency drives.

**Operating Distance:** 500+feet

**Frequency:** 450Mhz band  
**Number of available frequencies:** 256  
**Frequency generation:** Synthesized phase lock loop.

**Security coding:** 4 billion unique security codes available.

**Environment rating:** Outdoor use, IP65

**Licensing:** FCC certified, no license needed.

**Warranty:** 1 year, see manual

**Temperature Rating:** -35 to +75°C

#### Receiver mounting

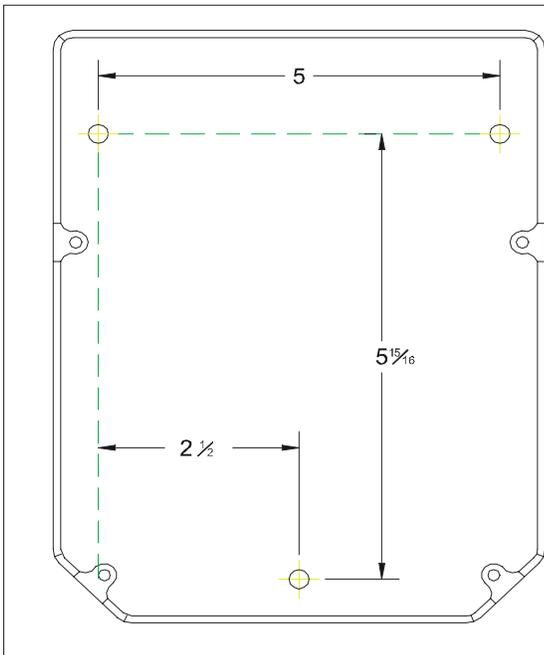

### Receiver Specifications

**Size:** 10" x 6.5" x 4.5", not including antenna or cable  
**Part #:** F22-6D-RX  
**Power supply input:** 120VAC (240VAC and 12 or 24V, AC or DC available)

**Relay ratings:** 5amp/250VAC  
**Error notification:** audible Morse Code via horn  
**Weight:** 7 lbs.  
**Includes:** Loud horn, large mainline indicator, emergency stop disconnect button. Totally pre-cabled.

**Accessories available:** Extended antenna kit for mounting receiver inside cabinets or mounting antenna in better position for reception.

#### Physical mounting specifications below

### Transmitter Specifications

**Part #:** F22-6D-TX  
**Transmitters:** 2 supplied standard.  
**Size:** W 2.5" x D 2.5" x L 6.5" (not including antenna)  
**Weight:** less than 1 lb.  
**Material:** shock resistant, fiber reinforced nylon  
**Power source:** 4 AA alkaline batteries.  
**Battery power indication:** LED and audible alarm.  
**Buttons:** 6 programmable, 2 step, plus start and stop. See programming and custom labeling sheet. Rated to 2 million cycles  
**Start key:** Removable  
**Stop Button:** mushroom style  
**Error notification:** audible Morse Code via buzzer  
**Includes:** shoulder straps and 4 AA batteries.



#### Receiver schematic

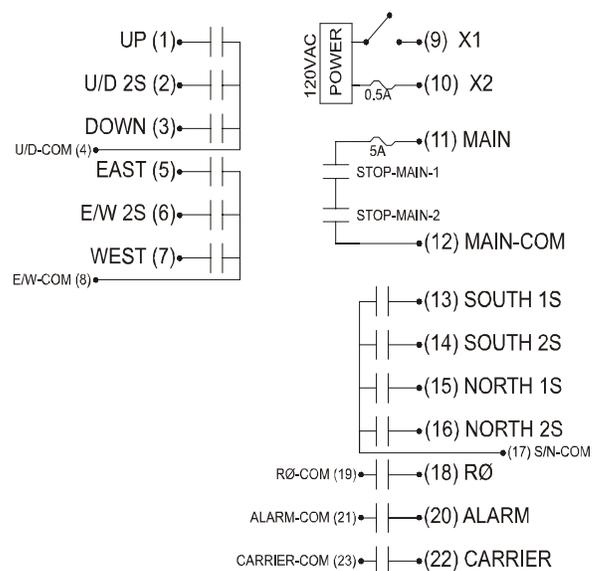

## Programming Sheet: F22-6D

**Acceleration delay for all button relays.**  
**Default setting of ZERO**

.3 seconds     2 seconds  
 1 second     3 seconds  
 1.5 seconds     4 seconds

**PASSWORD**

--	--	--	--

**Default (no password)**  
 Note: south and north can not be used in a password.

**normal, interlocked with button "DOWN"**

normal, not interlocked  
 toggle (on/off)  
 on (off is button "DOWN")

UP

DOWN

EAST

WEST

SOUTH

NORTH

**normal, interlocked with button "UP"**

normal, not interlocked  
 toggle (on/off)  
 off (on is button "UP")

**normal, interlocked with button "WEST"**

normal, not interlocked  
 toggle (on/off)  
 on (off is button "WEST")

**normal, interlocked with button "EAST"**

normal, not interlocked  
 toggle (on/off)  
 off (on is button "EAST")

**normal, interlocked with button "NORTH"**

normal, not interlocked  
 toggle (on/off)  
 ratchet up  
 inching .1 sec  
 inching .2 sec  
 inching .3 sec  
 inching .4 sec  
 inching .5 sec

**Auto Shut Down time**  
**Default setting of 1 hour**

never  
 10 minutes  
 20 minutes  
 30 minutes  
 **1 hour**  
 2 hours  
 3 hours  
 4 hours

**normal, interlocked with button "SOUTH"**

normal, not interlocked  
 toggle (on/off)  
 ratchet down

**Second function of START position Sound Alarm**

Close RØ momentary  
 Close RØ toggle

## Technical Sheet: F22-12D

### General Specifications

**Typical application:** Up to 6 motions, 2 step, overhead crane. Also A, B, A+B applications. Works great with variable frequency drives.

**Operating Distance:** 500+feet

**Frequency:** 450Mhz band

**Number of available frequencies:** 256

**Frequency generation:** Synthesized phase lock loop.

**Security coding:** 4 billion unique security codes available.

**Environment rating:** Outdoor use, IP65

**Licensing:** FCC certified, no license needed.

**Warranty:** 1 year, see manual

**Temperature Rating:** -35 to +75°C

### Receiver Specifications

**Size:** 10" x 6.5" x 4.5", not including antenna or cable

**Part #:** F22-12D-RX

**Power supply input:** 120VAC (240VAC and 12 or 24V, AC or DC available)

**Relay ratings:** 5amp/250VAC

**Error notification:** audible Morse Code via horn

**Weight:** 7 lbs.

**Includes:** Loud horn, large mainline indicator, emergency stop disconnect button. Totally pre-cabled.

**Accessories available:** Extended antenna kit for mounting receiver inside cabinets or mounting antenna in better position for reception.

**Physical mounting specifications below**

### Transmitter Specifications

**Part #:** F22-12D-TX

**Transmitters:** 2 supplied standard.

**Size:** W 2.5" x D 2.5" x L 7.25" (not including antenna)

**Weight:** less than 1 lb.

**Material:** shock resistant, fiber reinforced nylon

**Power source:** 4 AA alkaline batteries.

**Battery power indication:** LED and audible alarm.

**Buttons:** 12 programmable, 2 step, plus start and stop. See programming and custom labeling sheet. Rated to 2 million cycles

**Start key:** Removable

**Stop Button:** mushroom style

**Error notification:** audible Morse Code via buzzer

**Includes:** shoulder straps and 4 AA batteries.



#### Receiver mounting

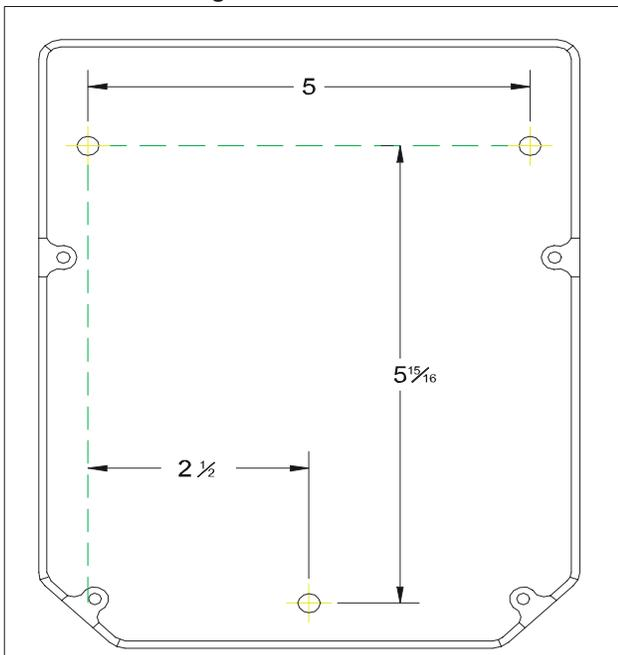

#### Receiver schematic

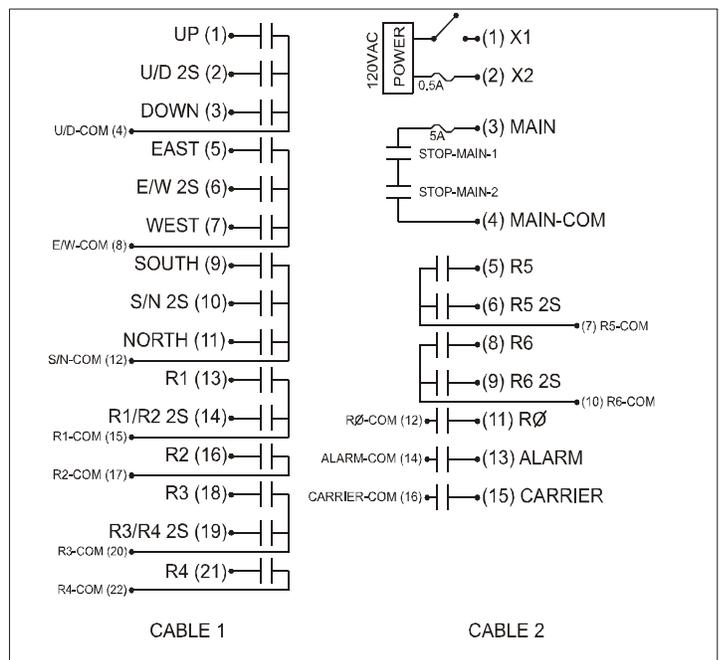

## Programming Sheet: F22-12D

<div style="border: 1px solid black; padding: 5px; margin-bottom: 5px;"> <table border="1" style="width: 100%; height: 30px; border-collapse: collapse;"> <tr><td style="width: 25px; height: 20px;"></td><td style="width: 25px; height: 20px;"></td><td style="width: 25px; height: 20px;"></td><td style="width: 25px; height: 20px;"></td></tr> <tr><td style="width: 25px; height: 20px;"></td><td style="width: 25px; height: 20px;"></td><td style="width: 25px; height: 20px;"></td><td style="width: 25px; height: 20px;"></td></tr> <tr><td style="width: 25px; height: 20px;"></td><td style="width: 25px; height: 20px;"></td><td style="width: 25px; height: 20px;"></td><td style="width: 25px; height: 20px;"></td></tr> </table> <p><b>normal, interlocked with button "DOWN"</b></p> <p><input type="radio"/> normal, not interlocked</p> <p><input type="radio"/> toggle (on/off)</p> <p><input type="radio"/> on (off is button "DOWN")</p> </div>													<p><b>Acceleration delay for all button relays.</b></p> <p><b>Default setting of ZERO</b></p> <p><input type="radio"/> .3 seconds    <input type="radio"/> 2 seconds</p> <p><input type="radio"/> 1 second    <input type="radio"/> 3 seconds</p> <p><input type="radio"/> 1.5 seconds    <input type="radio"/> 4 seconds</p> <p style="text-align: center;"><b>PASSWORD</b></p> <table border="1" style="width: 100%; height: 20px; border-collapse: collapse; margin: 0 auto;"> <tr><td style="width: 25px; height: 15px;"></td><td style="width: 25px; height: 15px;"></td><td style="width: 25px; height: 15px;"></td><td style="width: 25px; height: 15px;"></td></tr> </table> <p><b>Default (no password)</b> Note: 4, 5, and 6 can not be used in a password.</p>					<div style="border: 1px solid black; padding: 5px; margin-bottom: 5px;"> <table border="1" style="width: 100%; height: 30px; border-collapse: collapse;"> <tr><td style="width: 25px; height: 20px;"></td><td style="width: 25px; height: 20px;"></td><td style="width: 25px; height: 20px;"></td><td style="width: 25px; height: 20px;"></td></tr> <tr><td style="width: 25px; height: 20px;"></td><td style="width: 25px; height: 20px;"></td><td style="width: 25px; height: 20px;"></td><td style="width: 25px; height: 20px;"></td></tr> <tr><td style="width: 25px; height: 20px;"></td><td style="width: 25px; height: 20px;"></td><td style="width: 25px; height: 20px;"></td><td style="width: 25px; height: 20px;"></td></tr> </table> <p><b>normal, interlocked with button "UP"</b></p> <p><input type="radio"/> normal, not interlocked</p> <p><input type="radio"/> toggle (on/off)</p> <p><input type="radio"/> off (on is button "UP")</p> </div>												
<div style="border: 1px solid black; padding: 5px; margin-bottom: 5px;"> <table border="1" style="width: 100%; height: 30px; border-collapse: collapse;"> <tr><td style="width: 25px; height: 20px;"></td><td style="width: 25px; height: 20px;"></td><td style="width: 25px; height: 20px;"></td><td style="width: 25px; height: 20px;"></td></tr> <tr><td style="width: 25px; height: 20px;"></td><td style="width: 25px; height: 20px;"></td><td style="width: 25px; height: 20px;"></td><td style="width: 25px; height: 20px;"></td></tr> <tr><td style="width: 25px; height: 20px;"></td><td style="width: 25px; height: 20px;"></td><td style="width: 25px; height: 20px;"></td><td style="width: 25px; height: 20px;"></td></tr> </table> <p><b>normal, interlocked with button "WEST"</b></p> <p><input type="radio"/> normal, not interlocked</p> <p><input type="radio"/> toggle (on/off)</p> <p><input type="radio"/> on (off is button "WEST")</p> </div>													<div style="border: 1px solid black; width: 40px; height: 40px; margin: 0 auto; display: flex; align-items: center; justify-content: center;">UP</div> <div style="border: 1px solid black; width: 40px; height: 40px; margin: 0 auto; display: flex; align-items: center; justify-content: center;">DOWN</div>	<div style="border: 1px solid black; padding: 5px; margin-bottom: 5px;"> <table border="1" style="width: 100%; height: 30px; border-collapse: collapse;"> <tr><td style="width: 25px; height: 20px;"></td><td style="width: 25px; height: 20px;"></td><td style="width: 25px; height: 20px;"></td><td style="width: 25px; height: 20px;"></td></tr> <tr><td style="width: 25px; height: 20px;"></td><td style="width: 25px; height: 20px;"></td><td style="width: 25px; height: 20px;"></td><td style="width: 25px; height: 20px;"></td></tr> <tr><td style="width: 25px; height: 20px;"></td><td style="width: 25px; height: 20px;"></td><td style="width: 25px; height: 20px;"></td><td style="width: 25px; height: 20px;"></td></tr> </table> <p><b>normal, interlocked with button "EAST"</b></p> <p><input type="radio"/> normal, not interlocked</p> <p><input type="radio"/> toggle (on/off)</p> <p><input type="radio"/> off (on is button "EAST")</p> </div>																
<div style="border: 1px solid black; padding: 5px; margin-bottom: 5px;"> <table border="1" style="width: 100%; height: 30px; border-collapse: collapse;"> <tr><td style="width: 25px; height: 20px;"></td><td style="width: 25px; height: 20px;"></td><td style="width: 25px; height: 20px;"></td><td style="width: 25px; height: 20px;"></td></tr> <tr><td style="width: 25px; height: 20px;"></td><td style="width: 25px; height: 20px;"></td><td style="width: 25px; height: 20px;"></td><td style="width: 25px; height: 20px;"></td></tr> <tr><td style="width: 25px; height: 20px;"></td><td style="width: 25px; height: 20px;"></td><td style="width: 25px; height: 20px;"></td><td style="width: 25px; height: 20px;"></td></tr> </table> <p><b>normal, interlocked with button "NORTH"</b></p> <p><input type="radio"/> normal, not interlocked</p> <p><input type="radio"/> toggle (on/off)</p> <p><input type="radio"/> on (off is button "NORTH")</p> </div>													<div style="border: 1px solid black; width: 40px; height: 40px; margin: 0 auto; display: flex; align-items: center; justify-content: center;">EAST</div> <div style="border: 1px solid black; width: 40px; height: 40px; margin: 0 auto; display: flex; align-items: center; justify-content: center;">WEST</div>	<div style="border: 1px solid black; padding: 5px; margin-bottom: 5px;"> <table border="1" style="width: 100%; height: 30px; border-collapse: collapse;"> <tr><td style="width: 25px; height: 20px;"></td><td style="width: 25px; height: 20px;"></td><td style="width: 25px; height: 20px;"></td><td style="width: 25px; height: 20px;"></td></tr> <tr><td style="width: 25px; height: 20px;"></td><td style="width: 25px; height: 20px;"></td><td style="width: 25px; height: 20px;"></td><td style="width: 25px; height: 20px;"></td></tr> <tr><td style="width: 25px; height: 20px;"></td><td style="width: 25px; height: 20px;"></td><td style="width: 25px; height: 20px;"></td><td style="width: 25px; height: 20px;"></td></tr> </table> <p><b>normal, interlocked with button "SOUTH"</b></p> <p><input type="radio"/> normal, not interlocked</p> <p><input type="radio"/> toggle (on/off)</p> <p><input type="radio"/> off (on is button "SOUTH")</p> </div>																
<div style="border: 1px solid black; padding: 5px; margin-bottom: 5px;"> <table border="1" style="width: 100%; height: 30px; border-collapse: collapse;"> <tr><td style="width: 25px; height: 20px;"></td><td style="width: 25px; height: 20px;"></td><td style="width: 25px; height: 20px;"></td><td style="width: 25px; height: 20px;"></td></tr> <tr><td style="width: 25px; height: 20px;"></td><td style="width: 25px; height: 20px;"></td><td style="width: 25px; height: 20px;"></td><td style="width: 25px; height: 20px;"></td></tr> <tr><td style="width: 25px; height: 20px;"></td><td style="width: 25px; height: 20px;"></td><td style="width: 25px; height: 20px;"></td><td style="width: 25px; height: 20px;"></td></tr> </table> <p><b>normal, not interlocked</b></p> <p><input type="radio"/> normal, interlocked with button "2"</p> <p><input type="radio"/> toggle (on/off)</p> <p><input type="radio"/> on (off is button "2")</p> </div>													<div style="border: 1px solid black; width: 40px; height: 40px; margin: 0 auto; display: flex; align-items: center; justify-content: center;">1</div> <div style="border: 1px solid black; width: 40px; height: 40px; margin: 0 auto; display: flex; align-items: center; justify-content: center;">2</div>	<div style="border: 1px solid black; padding: 5px; margin-bottom: 5px;"> <table border="1" style="width: 100%; height: 30px; border-collapse: collapse;"> <tr><td style="width: 25px; height: 20px;"></td><td style="width: 25px; height: 20px;"></td><td style="width: 25px; height: 20px;"></td><td style="width: 25px; height: 20px;"></td></tr> <tr><td style="width: 25px; height: 20px;"></td><td style="width: 25px; height: 20px;"></td><td style="width: 25px; height: 20px;"></td><td style="width: 25px; height: 20px;"></td></tr> <tr><td style="width: 25px; height: 20px;"></td><td style="width: 25px; height: 20px;"></td><td style="width: 25px; height: 20px;"></td><td style="width: 25px; height: 20px;"></td></tr> </table> <p><b>normal, not interlocked</b></p> <p><input type="radio"/> normal, interlocked with button "1"</p> <p><input type="radio"/> toggle (on/off)</p> <p><input type="radio"/> off (on is button "1")</p> </div>																
<div style="border: 1px solid black; padding: 5px; margin-bottom: 5px;"> <table border="1" style="width: 100%; height: 30px; border-collapse: collapse;"> <tr><td style="width: 25px; height: 20px;"></td><td style="width: 25px; height: 20px;"></td><td style="width: 25px; height: 20px;"></td><td style="width: 25px; height: 20px;"></td></tr> <tr><td style="width: 25px; height: 20px;"></td><td style="width: 25px; height: 20px;"></td><td style="width: 25px; height: 20px;"></td><td style="width: 25px; height: 20px;"></td></tr> <tr><td style="width: 25px; height: 20px;"></td><td style="width: 25px; height: 20px;"></td><td style="width: 25px; height: 20px;"></td><td style="width: 25px; height: 20px;"></td></tr> </table> <p><b>normal, not interlocked</b></p> <p><input type="radio"/> normal, interlocked with button "4"</p> <p><input type="radio"/> toggle (on/off)</p> <p><input type="radio"/> on (off is button "4")</p> </div>													<div style="border: 1px solid black; width: 40px; height: 40px; margin: 0 auto; display: flex; align-items: center; justify-content: center;">3</div> <div style="border: 1px solid black; width: 40px; height: 40px; margin: 0 auto; display: flex; align-items: center; justify-content: center;">4</div>	<div style="border: 1px solid black; padding: 5px; margin-bottom: 5px;"> <table border="1" style="width: 100%; height: 30px; border-collapse: collapse;"> <tr><td style="width: 25px; height: 20px;"></td><td style="width: 25px; height: 20px;"></td><td style="width: 25px; height: 20px;"></td><td style="width: 25px; height: 20px;"></td></tr> <tr><td style="width: 25px; height: 20px;"></td><td style="width: 25px; height: 20px;"></td><td style="width: 25px; height: 20px;"></td><td style="width: 25px; height: 20px;"></td></tr> <tr><td style="width: 25px; height: 20px;"></td><td style="width: 25px; height: 20px;"></td><td style="width: 25px; height: 20px;"></td><td style="width: 25px; height: 20px;"></td></tr> </table> <p><b>normal, not interlocked</b></p> <p><input type="radio"/> normal interlocked with button "3"</p> <p><input type="radio"/> toggle (on/off)</p> <p><input type="radio"/> off (on is button "3")</p> </div>																
<div style="border: 1px solid black; padding: 5px; margin-bottom: 5px;"> <table border="1" style="width: 100%; height: 30px; border-collapse: collapse;"> <tr><td style="width: 25px; height: 20px;"></td><td style="width: 25px; height: 20px;"></td><td style="width: 25px; height: 20px;"></td><td style="width: 25px; height: 20px;"></td></tr> <tr><td style="width: 25px; height: 20px;"></td><td style="width: 25px; height: 20px;"></td><td style="width: 25px; height: 20px;"></td><td style="width: 25px; height: 20px;"></td></tr> <tr><td style="width: 25px; height: 20px;"></td><td style="width: 25px; height: 20px;"></td><td style="width: 25px; height: 20px;"></td><td style="width: 25px; height: 20px;"></td></tr> </table> <p><b>normal, not interlocked</b></p> <p><input type="radio"/> toggle (on/off)    <input type="radio"/> inching .2 seconds</p> <p><input type="radio"/> ratchet up    <input type="radio"/> inching .3 seconds</p> <p><input type="radio"/> inching .1 second    <input type="radio"/> inching .4 seconds</p> <p>                                  <input type="radio"/> inching .5 seconds</p> </div>													<div style="border: 1px solid black; width: 40px; height: 40px; margin: 0 auto; display: flex; align-items: center; justify-content: center;">5</div> <div style="border: 1px solid black; width: 40px; height: 40px; margin: 0 auto; display: flex; align-items: center; justify-content: center;">6</div>	<div style="border: 1px solid black; padding: 5px; margin-bottom: 5px;"> <table border="1" style="width: 100%; height: 30px; border-collapse: collapse;"> <tr><td style="width: 25px; height: 20px;"></td><td style="width: 25px; height: 20px;"></td><td style="width: 25px; height: 20px;"></td><td style="width: 25px; height: 20px;"></td></tr> <tr><td style="width: 25px; height: 20px;"></td><td style="width: 25px; height: 20px;"></td><td style="width: 25px; height: 20px;"></td><td style="width: 25px; height: 20px;"></td></tr> <tr><td style="width: 25px; height: 20px;"></td><td style="width: 25px; height: 20px;"></td><td style="width: 25px; height: 20px;"></td><td style="width: 25px; height: 20px;"></td></tr> </table> <p><b>normal, not interlocked</b></p> <p><input type="radio"/> toggle (on/off)</p> <p><input type="radio"/> ratchet down</p> </div>																

## Technical Sheet: F22-2D1

### General Specifications

**Typical application:** 1 motion, 2 step, hoist. Works great with variable frequency drives.

**Operating Distance:** 300+feet

**Frequency:** 450Mhz band

**Number of available frequencies:** 256

**Frequency generation:** Synthesized phase lock loop.

**Security coding:** 4 billion unique security codes available.

**Environment rating:** Outdoor use, IP65

**Licensing:** FCC certified, no license needed.

**Warranty:** 1 year, see manual

**Temperature Rating:** -35 to +75°C

### Receiver Specifications

**Size:** 10" x 6.5" x 4.5", not including antenna or cable

**Part #:** F22-6D-RX

**Power supply input:** 120VAC (240VAC and 12 or 24V, AC or DC available)

**Relay ratings:** 5amp/250VAC

**Error notification:** audible Morse Code via horn

**Weight:** 7 lbs.

**Includes:** Loud horn, large mainline indicator, emergency stop disconnect button. Totally precabled.

**Accessories available:** Extended antenna kit for mounting receiver inside cabinets or mounting antenna in better position for reception.

**Physical mounting specifications below**

### Transmitter Specifications

**Part #:** F22-2D1-TX

**Transmitters:** 2 supplied standard.

**Size:** W 2.4" x D 2.75" x L 8.5" (not including antenna)

**Weight:** 1 lb.

**Material:** shock resistant, fiber reinforced nylon

**Power source:** 4 AA alkaline batteries.

**Battery power indication:** LED and audible alarm.

**Buttons:** 2 programmable, 2 step, plus start and stop. See programming and custom labeling sheet. Rated to 2 million cycles

**Start key:** Removable

**Stop Button:** mushroom style

**Error notification:** audible Morse Code via buzzer

**Includes:** shoulder straps and 4 AA batteries.



### Receiver mounting

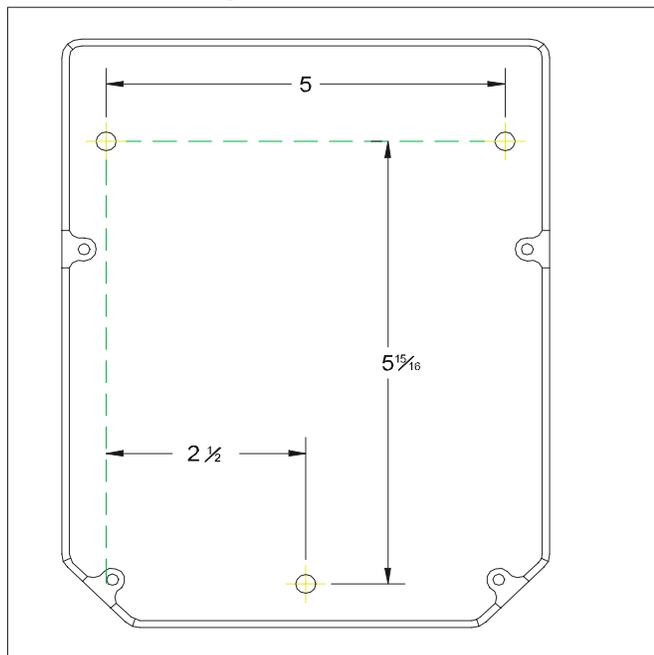

### Receiver schematic

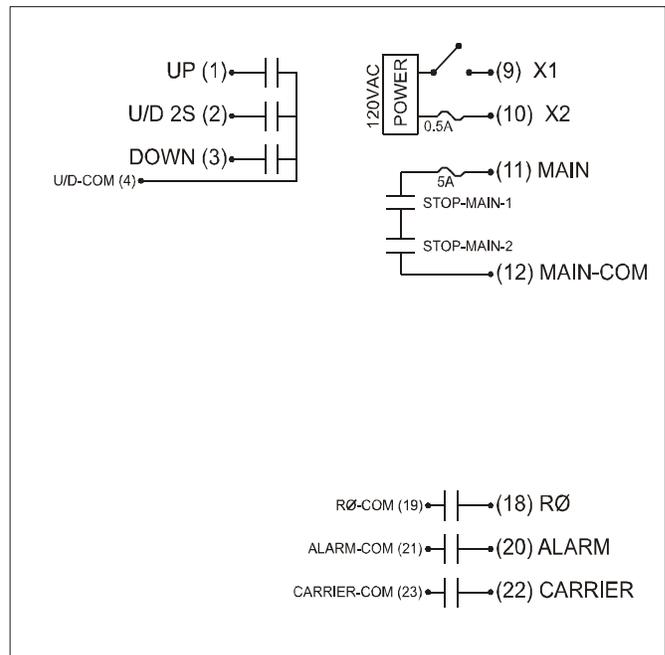

## Programming Sheet: F22-2D1

<p><b>Acceleration delay for all button relays.</b>  <b>Default setting of ZERO</b></p> <p> <input type="radio"/> .3 seconds    <input type="radio"/> 2 seconds  <input type="radio"/> 1 second     <input type="radio"/> 3 seconds  <input type="radio"/> 1.5 seconds   <input type="radio"/> 4 seconds         </p> <p style="text-align: center;">PASSWORD</p> <table border="1" style="margin: auto; border-collapse: collapse;"> <tr> <td style="width: 20px; height: 20px;"></td> <td style="width: 20px; height: 20px;"></td> <td style="width: 20px; height: 20px;"></td> <td style="width: 20px; height: 20px;"></td> </tr> </table> <p style="text-align: center;">Default (no password)</p> <p><b>Auto Shut Down time</b>  <b>Default setting of 1 hour</b></p> <p> <input type="radio"/> never  <input type="radio"/> 10 minutes  <input type="radio"/> 20 minutes  <input type="radio"/> 30 minutes  <input type="radio"/> <b>1 hour</b>  <input type="radio"/> 2 hours  <input type="radio"/> 3 hours  <input type="radio"/> 4 hours         </p>					<div style="border: 1px solid black; border-radius: 50%; width: 60px; height: 60px; margin: 0 auto; display: flex; align-items: center; justify-content: center;">UP</div>  <div style="border: 1px solid black; border-radius: 50%; width: 60px; height: 60px; margin: 0 auto; display: flex; align-items: center; justify-content: center;">DOWN</div>	<table border="1" style="width: 100%; border-collapse: collapse;"> <tr> <td style="width: 20px; height: 20px;"></td> <td style="width: 20px; height: 20px;"></td> <td style="width: 20px; height: 20px;"></td> <td style="width: 20px; height: 20px;"></td> <td style="width: 20px; height: 20px;"></td> <td style="width: 20px; height: 20px;"></td> <td style="width: 20px; height: 20px;"></td> <td style="width: 20px; height: 20px;"></td> </tr> <tr> <td style="width: 20px; height: 20px;"></td> <td style="width: 20px; height: 20px;"></td> <td style="width: 20px; height: 20px;"></td> <td style="width: 20px; height: 20px;"></td> <td style="width: 20px; height: 20px;"></td> <td style="width: 20px; height: 20px;"></td> <td style="width: 20px; height: 20px;"></td> <td style="width: 20px; height: 20px;"></td> </tr> <tr> <td style="width: 20px; height: 20px;"></td> <td style="width: 20px; height: 20px;"></td> <td style="width: 20px; height: 20px;"></td> <td style="width: 20px; height: 20px;"></td> <td style="width: 20px; height: 20px;"></td> <td style="width: 20px; height: 20px;"></td> <td style="width: 20px; height: 20px;"></td> <td style="width: 20px; height: 20px;"></td> </tr> </table> <p><b>normal, interlocked with button "DOWN"</b></p> <p> <input type="radio"/> normal, not interlocked  <input type="radio"/> toggle (on/off)  <input type="radio"/> on (off is button "DOWN")         </p> <hr/> <table border="1" style="width: 100%; border-collapse: collapse;"> <tr> <td style="width: 20px; height: 20px;"></td> <td style="width: 20px; height: 20px;"></td> <td style="width: 20px; height: 20px;"></td> <td style="width: 20px; height: 20px;"></td> <td style="width: 20px; height: 20px;"></td> <td style="width: 20px; height: 20px;"></td> <td style="width: 20px; height: 20px;"></td> <td style="width: 20px; height: 20px;"></td> </tr> <tr> <td style="width: 20px; height: 20px;"></td> <td style="width: 20px; height: 20px;"></td> <td style="width: 20px; height: 20px;"></td> <td style="width: 20px; height: 20px;"></td> <td style="width: 20px; height: 20px;"></td> <td style="width: 20px; height: 20px;"></td> <td style="width: 20px; height: 20px;"></td> <td style="width: 20px; height: 20px;"></td> </tr> <tr> <td style="width: 20px; height: 20px;"></td> <td style="width: 20px; height: 20px;"></td> <td style="width: 20px; height: 20px;"></td> <td style="width: 20px; height: 20px;"></td> <td style="width: 20px; height: 20px;"></td> <td style="width: 20px; height: 20px;"></td> <td style="width: 20px; height: 20px;"></td> <td style="width: 20px; height: 20px;"></td> </tr> </table> <p><b>normal, interlocked with button "UP"</b></p> <p> <input type="radio"/> normal, not interlocked  <input type="radio"/> toggle (on/off)  <input type="radio"/> off (on is button "UP")         </p>																																																
<p style="text-align: center;"><b>Second function of START position</b>  <b>Sound Alarm</b></p> <p> <input type="radio"/> Close RØ momentary  <input type="radio"/> Close RØ toggle         </p>																																																						



## Technical Sheet: F22-4D1

### General Specifications

**Typical application:** 2 motion, 2 step, monorail. Works great with variable frequency drives.

**Operating Distance:** 500+feet  
**Frequency:** 450Mhz band  
**Number of available frequencies:** 256  
**Frequency generation:** Synthesized phase lock loop.  
**Security coding:** 4 billion unique security codes available.

**Environment rating:** Outdoor use, IP65  
**Licensing:** FCC certified, no license needed.  
**Warranty:** 1 year, see manual  
**Temperature Rating:** -35 to +75°C

### Receiver Specifications

**Size:** 10" x 6.5" x 4.5", not including antenna or cable  
**Part #:** F22-6D-RX  
**Power supply input:** 120VAC (240VAC and 12 or 24V, AC or DC available)  
**Relay ratings:** 5amp/250VAC  
**Error notification:** audible Morse Code via horn  
**Weight:** 7 lbs.

**Includes:** Loud horn, large mainline indicator, emergency stop disconnect button. Totally pre-cabled.  
**Accessories available:** Extended antenna kit for mounting receiver inside cabinets or mounting antenna in better position for reception.

### Physical mounting specifications below

### Transmitter Specifications

**Part #:** F22-4D1-TX  
**Transmitters:** 2 supplied standard.  
**Size:** W 2.4" x D 2.75" x L 8.5" (not including antenna)  
**Weight:** 1 lb.  
**Material:** shock resistant, fiber reinforced nylon  
**Power source:** 4 AA alkaline batteries.  
**Battery power indication:** LED and audible alarm.  
**Buttons:** 4 programmable, 2 step, plus start and stop. See programming and custom labeling sheet. Rated to 2 million cycles  
**Start key:** Removable  
**Stop Button:** mushroom style  
**Error notification:** audible Morse Code via buzzer  
**Includes:** shoulder straps and 4 AA batteries.



### Receiver mounting

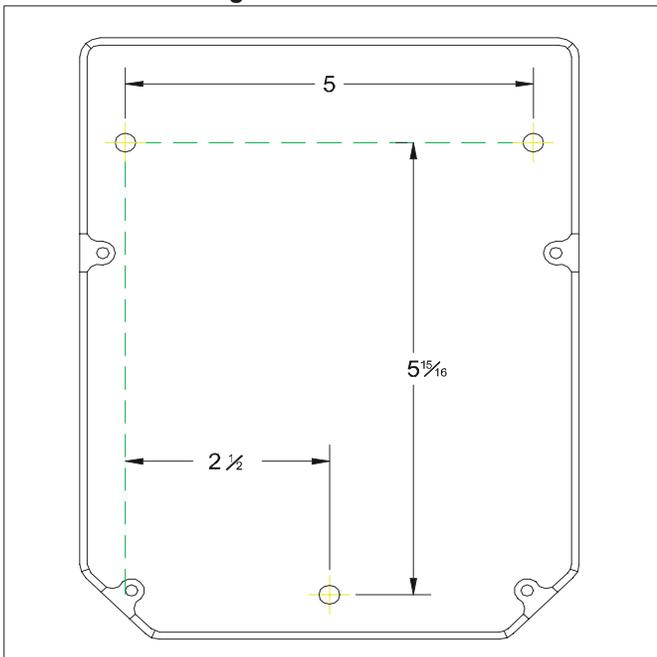

### Receiver schematic

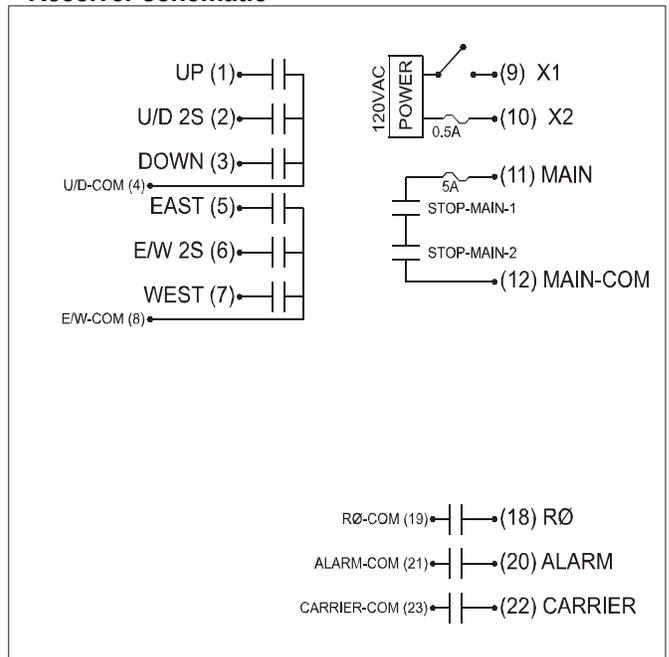

## Programming Sheet: F22-4D1

<p><b>Second function of START position</b> <b>Sound Alarm</b></p> <p><input type="radio"/> Close RØ momentary <input type="radio"/> Close RØ toggle</p> <p><b>Acceleration delay for all button relays.</b> <b>Default setting of ZERO</b></p> <p><input type="radio"/> .3 seconds    <input type="radio"/> 2 seconds <input type="radio"/> 1 second      <input type="radio"/> 3 seconds <input type="radio"/> 1.5 seconds   <input type="radio"/> 4 seconds</p> <p style="text-align: center;">PASSWORD</p> <table style="margin: auto; border: 1px solid black; width: 100px; height: 20px;"> <tr> <td style="width: 25px; height: 20px;"></td> <td style="width: 25px; height: 20px;"></td> <td style="width: 25px; height: 20px;"></td> <td style="width: 25px; height: 20px;"></td> </tr> </table> <p style="text-align: center;">Default (no password)</p> <p><b>Auto Shut Down time</b> <b>Default setting of 1 hour</b></p> <p><input type="radio"/> never <input type="radio"/> 10 minutes <input type="radio"/> 20 minutes <input type="radio"/> 30 minutes <b>1 hour</b> <input type="radio"/> 2 hours <input type="radio"/> 3 hours <input type="radio"/> 4 hours</p>					<p>UP</p> <p>DOWN</p> <p>EAST</p> <p>WEST</p>	<table border="1" style="width: 100%; border-collapse: collapse;"> <tr> <td style="width: 100px; height: 100px; vertical-align: middle; text-align: center;">UP</td> <td style="padding: 5px;"> <table style="width: 100%; border-collapse: collapse;"> <tr><td style="width: 25px; height: 20px;"></td><td style="width: 25px; height: 20px;"></td><td style="width: 25px; height: 20px;"></td><td style="width: 25px; height: 20px;"></td></tr> <tr><td style="width: 25px; height: 20px;"></td><td style="width: 25px; height: 20px;"></td><td style="width: 25px; height: 20px;"></td><td style="width: 25px; height: 20px;"></td></tr> <tr><td style="width: 25px; height: 20px;"></td><td style="width: 25px; height: 20px;"></td><td style="width: 25px; height: 20px;"></td><td style="width: 25px; height: 20px;"></td></tr> </table> <p><b>normal, interlocked with button "DOWN"</b></p> <p><input type="radio"/> normal, not interlocked <input type="radio"/> toggle (on/off) <input type="radio"/> on (off is button "DOWN")</p> </td> </tr> <tr> <td style="width: 100px; height: 100px; vertical-align: middle; text-align: center;">DOWN</td> <td style="padding: 5px;"> <table style="width: 100%; border-collapse: collapse;"> <tr><td style="width: 25px; height: 20px;"></td><td style="width: 25px; height: 20px;"></td><td style="width: 25px; height: 20px;"></td><td style="width: 25px; height: 20px;"></td></tr> <tr><td style="width: 25px; height: 20px;"></td><td style="width: 25px; height: 20px;"></td><td style="width: 25px; height: 20px;"></td><td style="width: 25px; height: 20px;"></td></tr> <tr><td style="width: 25px; height: 20px;"></td><td style="width: 25px; height: 20px;"></td><td style="width: 25px; height: 20px;"></td><td style="width: 25px; height: 20px;"></td></tr> </table> <p><b>normal, interlocked with button "UP"</b></p> <p><input type="radio"/> normal, not interlocked <input type="radio"/> toggle (on/off) <input type="radio"/> off (on is button "UP")</p> </td> </tr> <tr> <td style="width: 100px; height: 100px; vertical-align: middle; text-align: center;">EAST</td> <td style="padding: 5px;"> <table style="width: 100%; border-collapse: collapse;"> <tr><td style="width: 25px; height: 20px;"></td><td style="width: 25px; height: 20px;"></td><td style="width: 25px; height: 20px;"></td><td style="width: 25px; height: 20px;"></td></tr> <tr><td style="width: 25px; height: 20px;"></td><td style="width: 25px; height: 20px;"></td><td style="width: 25px; height: 20px;"></td><td style="width: 25px; height: 20px;"></td></tr> <tr><td style="width: 25px; height: 20px;"></td><td style="width: 25px; height: 20px;"></td><td style="width: 25px; height: 20px;"></td><td style="width: 25px; height: 20px;"></td></tr> </table> <p><b>normal, interlocked with button "WEST"</b></p> <p><input type="radio"/> normal, not interlocked <input type="radio"/> toggle (on/off) <input type="radio"/> on (off is button "WEST")</p> </td> </tr> <tr> <td style="width: 100px; height: 100px; vertical-align: middle; text-align: center;">WEST</td> <td style="padding: 5px;"> <table style="width: 100%; border-collapse: collapse;"> <tr><td style="width: 25px; height: 20px;"></td><td style="width: 25px; height: 20px;"></td><td style="width: 25px; height: 20px;"></td><td style="width: 25px; height: 20px;"></td></tr> <tr><td style="width: 25px; height: 20px;"></td><td style="width: 25px; height: 20px;"></td><td style="width: 25px; height: 20px;"></td><td style="width: 25px; height: 20px;"></td></tr> <tr><td style="width: 25px; height: 20px;"></td><td style="width: 25px; height: 20px;"></td><td style="width: 25px; height: 20px;"></td><td style="width: 25px; height: 20px;"></td></tr> </table> <p><b>normal, interlocked with button "EAST"</b></p> <p><input type="radio"/> normal, not interlocked <input type="radio"/> toggle (on/off) <input type="radio"/> off (on is button "EAST")</p> </td> </tr> </table>	UP	<table style="width: 100%; border-collapse: collapse;"> <tr><td style="width: 25px; height: 20px;"></td><td style="width: 25px; height: 20px;"></td><td style="width: 25px; height: 20px;"></td><td style="width: 25px; height: 20px;"></td></tr> <tr><td style="width: 25px; height: 20px;"></td><td style="width: 25px; height: 20px;"></td><td style="width: 25px; height: 20px;"></td><td style="width: 25px; height: 20px;"></td></tr> <tr><td style="width: 25px; height: 20px;"></td><td style="width: 25px; height: 20px;"></td><td style="width: 25px; height: 20px;"></td><td style="width: 25px; height: 20px;"></td></tr> </table> <p><b>normal, interlocked with button "DOWN"</b></p> <p><input type="radio"/> normal, not interlocked <input type="radio"/> toggle (on/off) <input type="radio"/> on (off is button "DOWN")</p>													DOWN	<table style="width: 100%; border-collapse: collapse;"> <tr><td style="width: 25px; height: 20px;"></td><td style="width: 25px; height: 20px;"></td><td style="width: 25px; height: 20px;"></td><td style="width: 25px; height: 20px;"></td></tr> <tr><td style="width: 25px; height: 20px;"></td><td style="width: 25px; height: 20px;"></td><td style="width: 25px; height: 20px;"></td><td style="width: 25px; height: 20px;"></td></tr> <tr><td style="width: 25px; height: 20px;"></td><td style="width: 25px; height: 20px;"></td><td style="width: 25px; height: 20px;"></td><td style="width: 25px; height: 20px;"></td></tr> </table> <p><b>normal, interlocked with button "UP"</b></p> <p><input type="radio"/> normal, not interlocked <input type="radio"/> toggle (on/off) <input type="radio"/> off (on is button "UP")</p>													EAST	<table style="width: 100%; border-collapse: collapse;"> <tr><td style="width: 25px; height: 20px;"></td><td style="width: 25px; height: 20px;"></td><td style="width: 25px; height: 20px;"></td><td style="width: 25px; height: 20px;"></td></tr> <tr><td style="width: 25px; height: 20px;"></td><td style="width: 25px; height: 20px;"></td><td style="width: 25px; height: 20px;"></td><td style="width: 25px; height: 20px;"></td></tr> <tr><td style="width: 25px; height: 20px;"></td><td style="width: 25px; height: 20px;"></td><td style="width: 25px; height: 20px;"></td><td style="width: 25px; height: 20px;"></td></tr> </table> <p><b>normal, interlocked with button "WEST"</b></p> <p><input type="radio"/> normal, not interlocked <input type="radio"/> toggle (on/off) <input type="radio"/> on (off is button "WEST")</p>													WEST	<table style="width: 100%; border-collapse: collapse;"> <tr><td style="width: 25px; height: 20px;"></td><td style="width: 25px; height: 20px;"></td><td style="width: 25px; height: 20px;"></td><td style="width: 25px; height: 20px;"></td></tr> <tr><td style="width: 25px; height: 20px;"></td><td style="width: 25px; height: 20px;"></td><td style="width: 25px; height: 20px;"></td><td style="width: 25px; height: 20px;"></td></tr> <tr><td style="width: 25px; height: 20px;"></td><td style="width: 25px; height: 20px;"></td><td style="width: 25px; height: 20px;"></td><td style="width: 25px; height: 20px;"></td></tr> </table> <p><b>normal, interlocked with button "EAST"</b></p> <p><input type="radio"/> normal, not interlocked <input type="radio"/> toggle (on/off) <input type="radio"/> off (on is button "EAST")</p>												
UP	<table style="width: 100%; border-collapse: collapse;"> <tr><td style="width: 25px; height: 20px;"></td><td style="width: 25px; height: 20px;"></td><td style="width: 25px; height: 20px;"></td><td style="width: 25px; height: 20px;"></td></tr> <tr><td style="width: 25px; height: 20px;"></td><td style="width: 25px; height: 20px;"></td><td style="width: 25px; height: 20px;"></td><td style="width: 25px; height: 20px;"></td></tr> <tr><td style="width: 25px; height: 20px;"></td><td style="width: 25px; height: 20px;"></td><td style="width: 25px; height: 20px;"></td><td style="width: 25px; height: 20px;"></td></tr> </table> <p><b>normal, interlocked with button "DOWN"</b></p> <p><input type="radio"/> normal, not interlocked <input type="radio"/> toggle (on/off) <input type="radio"/> on (off is button "DOWN")</p>																																																													
DOWN	<table style="width: 100%; border-collapse: collapse;"> <tr><td style="width: 25px; height: 20px;"></td><td style="width: 25px; height: 20px;"></td><td style="width: 25px; height: 20px;"></td><td style="width: 25px; height: 20px;"></td></tr> <tr><td style="width: 25px; height: 20px;"></td><td style="width: 25px; height: 20px;"></td><td style="width: 25px; height: 20px;"></td><td style="width: 25px; height: 20px;"></td></tr> <tr><td style="width: 25px; height: 20px;"></td><td style="width: 25px; height: 20px;"></td><td style="width: 25px; height: 20px;"></td><td style="width: 25px; height: 20px;"></td></tr> </table> <p><b>normal, interlocked with button "UP"</b></p> <p><input type="radio"/> normal, not interlocked <input type="radio"/> toggle (on/off) <input type="radio"/> off (on is button "UP")</p>																																																													
EAST	<table style="width: 100%; border-collapse: collapse;"> <tr><td style="width: 25px; height: 20px;"></td><td style="width: 25px; height: 20px;"></td><td style="width: 25px; height: 20px;"></td><td style="width: 25px; height: 20px;"></td></tr> <tr><td style="width: 25px; height: 20px;"></td><td style="width: 25px; height: 20px;"></td><td style="width: 25px; height: 20px;"></td><td style="width: 25px; height: 20px;"></td></tr> <tr><td style="width: 25px; height: 20px;"></td><td style="width: 25px; height: 20px;"></td><td style="width: 25px; height: 20px;"></td><td style="width: 25px; height: 20px;"></td></tr> </table> <p><b>normal, interlocked with button "WEST"</b></p> <p><input type="radio"/> normal, not interlocked <input type="radio"/> toggle (on/off) <input type="radio"/> on (off is button "WEST")</p>																																																													
WEST	<table style="width: 100%; border-collapse: collapse;"> <tr><td style="width: 25px; height: 20px;"></td><td style="width: 25px; height: 20px;"></td><td style="width: 25px; height: 20px;"></td><td style="width: 25px; height: 20px;"></td></tr> <tr><td style="width: 25px; height: 20px;"></td><td style="width: 25px; height: 20px;"></td><td style="width: 25px; height: 20px;"></td><td style="width: 25px; height: 20px;"></td></tr> <tr><td style="width: 25px; height: 20px;"></td><td style="width: 25px; height: 20px;"></td><td style="width: 25px; height: 20px;"></td><td style="width: 25px; height: 20px;"></td></tr> </table> <p><b>normal, interlocked with button "EAST"</b></p> <p><input type="radio"/> normal, not interlocked <input type="radio"/> toggle (on/off) <input type="radio"/> off (on is button "EAST")</p>																																																													

## Technical Sheet: F22-6D1

### General Specifications

**Typical application:** 3 motion, 2 step, overhead crane. Works great with variable frequency drives.

**Operating Distance:** 500+feet

**Frequency:** 450Mhz band

**Number of available frequencies:** 256

**Frequency generation:** Synthesized phase lock loop.

**Security coding:** 4 billion unique security codes available.

**Environment rating:** Outdoor use, IP65

**Licensing:** FCC certified, no license needed.

**Warranty:** 1 year, see manual

**Temperature Rating:** -35 to +75°C

#### Receiver mounting

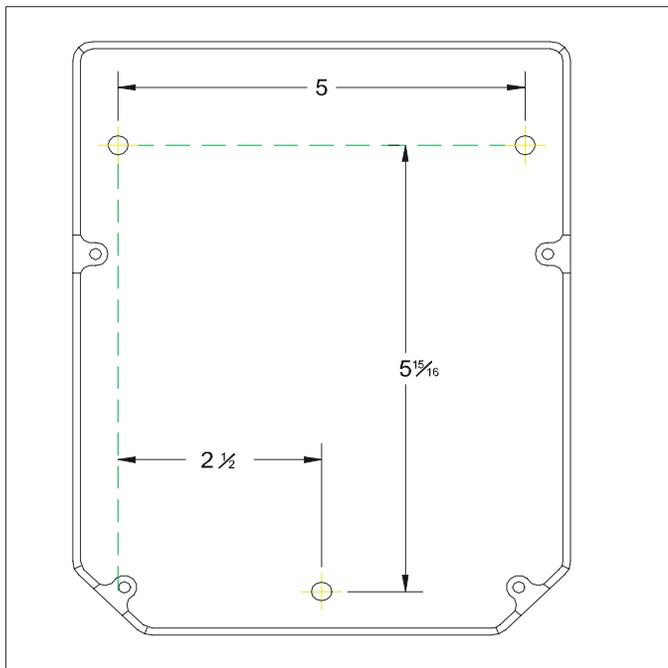

### Receiver Specifications

**Size:** 10" x 6.5" x 4.5", not including antenna or cable

**Part #:** F22-6D-RX

**Power supply input:** 120VAC (240VAC and 12 or 24V, AC or DC available)

**Relay ratings:** 5amp/250VAC

**Error notification:** audible Morse Code via horn

**Weight:** 7 lbs.

**Includes:** Loud horn, large mainline indicator, emergency stop disconnect button. Totally pre-cabled.

**Accessories available:** Extended antenna kit for mounting receiver inside cabinets or mounting antenna in better position for reception.

#### Physical mounting specifications below

### Transmitter Specifications

**Part #:** F22-6D1-TX

**Transmitters:** 2 supplied standard.

**Size:** W 2.4" x D 2.75" x L 8.5" (not including antenna)

**Weight:** 1 lb.

**Material:** shock resistant, fiber reinforced nylon

**Power source:** 4 AA alkaline batteries.

**Battery power indication:** LED and audible alarm.

**Buttons:** 6 programmable, 2 step, plus start and stop. See programming and custom labeling sheet. Rated to 2 million cycles

**Start key:** Removable

**Stop Button:** mushroom style

**Error notification:** audible Morse Code via buzzer

**Includes:** shoulder straps and 4 AA batteries.



#### Receiver schematic

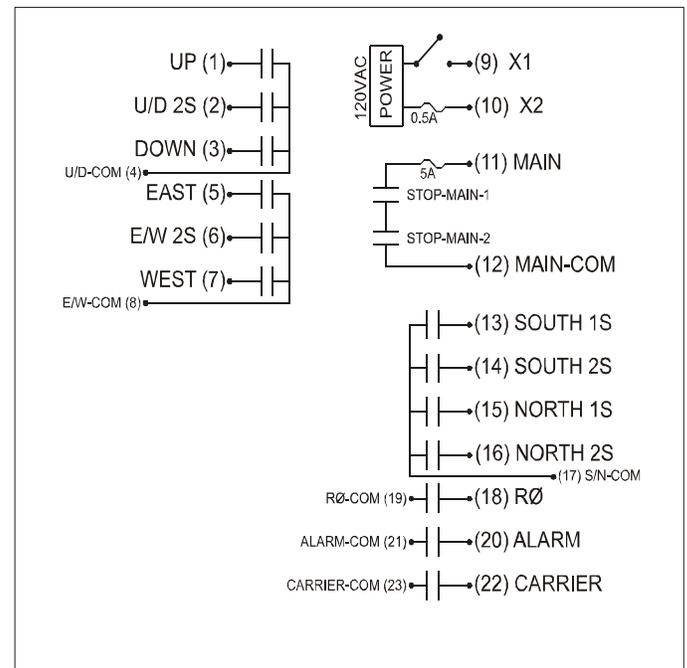

## Programming Sheet: F22-6D1

**Acceleration delay for all button relays.**

**Default setting of ZERO**

- .3 seconds       2 seconds
- 1 second         3 seconds
- 1.5 seconds      4 seconds

PASSWORD

--	--	--	--

**Default (no password)**

Note: south and north may not be used in a password.

**Auto Shut Down time**

**Default setting of 1 hour**

- never
- 10 minutes
- 20 minutes
- 30 minutes
- 1 hour**
- 2 hours
- 3 hours
- 4 hours

**normal, interlocked with button "NORTH"**

- normal, not interlocked
- toggle (on/off)
- ratchet up
- inching .1 sec
- inching .2 sec
- inching .3 sec
- inching .4 sec
- inching .5 sec

**normal, interlocked with button "SOUTH"**

- normal, not interlocked
- toggle (on/off)
- ratchet down

UP

DOWN

EAST

WEST

SOUTH

NORTH

**normal, interlocked with button "DOWN"**

- normal, not interlocked
- toggle (on/off)
- on (off is button "DOWN")

**normal, interlocked with button "UP"**

- normal, not interlocked
- toggle (on/off)
- off (on is button "UP")

**normal, interlocked with button "WEST"**

- normal, not interlocked
- toggle (on/off)
- on (off is button "WEST")

**normal, interlocked with button "EAST"**

- normal, not interlocked
- toggle (on/off)
- off (on is button "EAST")

**Second function of START position**  
**Sound Alarm**

- Close RØ momentary
- Close RØ toggle

# Technical Sheet: F22-10D1

## General Specifications

**Typical application:** Up to 5 motions, 2 step, overhead crane. Also A, B, A+B applications. Works great with variable frequency drives.

**Operating Distance:** 500+feet

**Frequency:** 450Mhz band

**Number of available frequencies:** 256

**Frequency generation:**

Synthesized phase lock loop.

**Security coding:** 4 billion unique security codes available.

**Environment rating:** Outdoor use, IP65

**Licensing:** FCC certified, no license needed.

**Warranty:** 1 year, see manual

**Temperature Rating:** -35 to +75°C

### Receiver mounting

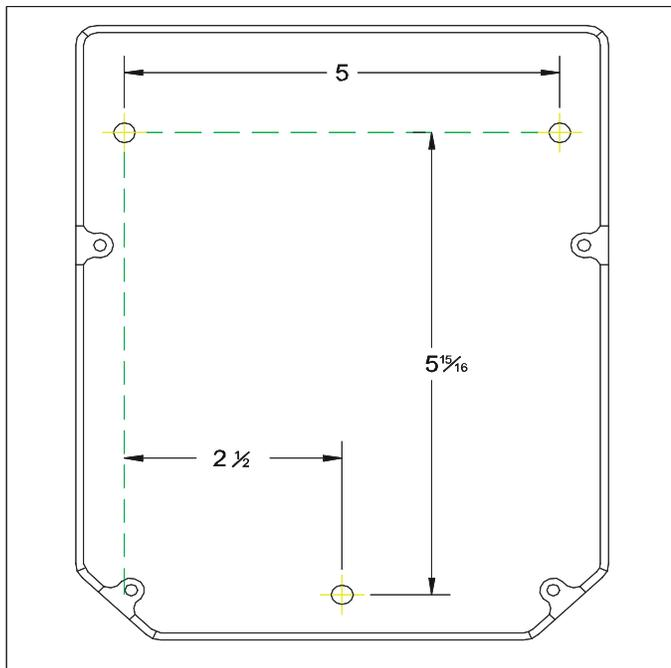

## Receiver Specifications

**Size:** 10" x 6.5" x 4.5", not including antenna or cable

**Part #:** F22-12D-RX

**Power supply input:** 120VAC (240VAC and 12 or 24V, AC or DC available)

**Relay ratings:** 5amp/250VAC

**Error notification:** audible Morse Code via horn

**Weight:** 7 lbs.

**Includes:** Loud horn, large mainline indicator, emergency stop disconnect button. Totally pre-cabled.

**Accessories available:** Extended antenna kit for mounting receiver inside cabinets or mounting antenna in better position for reception.

### Physical mounting specifications below

## Transmitter Specifications

**Part #:** F22-10D1-TX

**Transmitters:** 2 supplied standard.

**Size:** W 2.4" x D 2.75" x L 8.5" (not including antenna)

**Weight:** 1 lb.

**Material:** shock resistant, fiber reinforced nylon

**Power source:** 4 AA alkaline batteries.

**Battery power indication:** LED and audible alarm.

**Buttons:** 10 programmable, 2 step, plus start and stop. See programming and custom labeling sheet. Rated to 2 million cycles

**Start key:** Removable

**Stop Button:** mushroom style

**Error notification:** audible Morse Code via buzzer

**Includes:** shoulder straps and 4 AA batteries.



### Receiver schematic

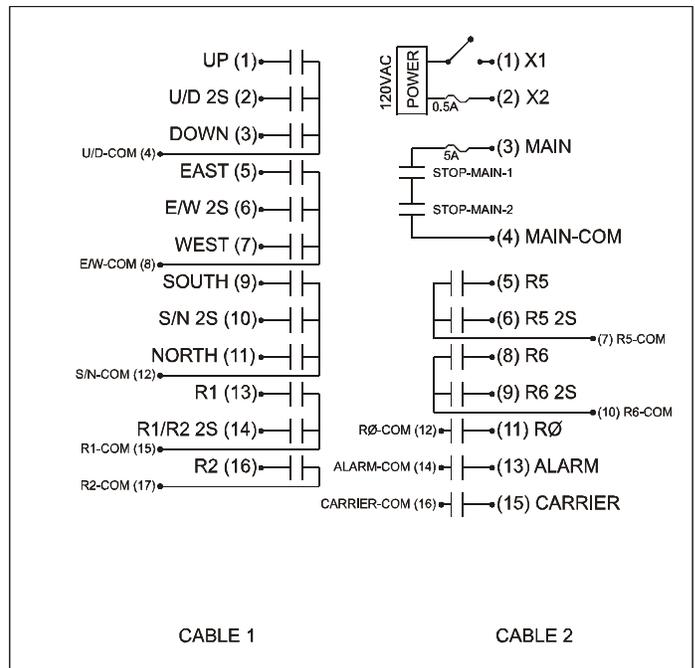

## Programming Sheet: F22-10D1

<p><b>Acceleration delay for all button relays.</b>  <b>Default setting of ZERO</b></p> <p> <input type="radio"/> .3 seconds    <input type="radio"/> 2 seconds  <input type="radio"/> 1 second    <input type="radio"/> 3 seconds  <input type="radio"/> 1.5 seconds    <input type="radio"/> 4 seconds         </p>	<p style="text-align: center;">PASSWORD</p> <div style="border: 1px solid black; width: 100px; height: 20px; margin: 0 auto;"></div> <p><b>Default (no password)</b>          Note: 5 and 6 may not be used in a password.</p>	<div style="border: 1px solid black; width: 100%; height: 100%; display: flex; flex-direction: column; align-items: center; justify-content: center;"> <div style="display: flex; align-items: center; margin-bottom: 10px;"> <div style="border: 1px solid black; border-radius: 50%; width: 40px; height: 40px; display: flex; align-items: center; justify-content: center; margin-right: 10px;">1</div> <div style="border: 1px solid black; border-radius: 50%; width: 40px; height: 40px; display: flex; align-items: center; justify-content: center;">UP</div> </div> <div style="display: flex; align-items: center; margin-bottom: 10px;"> <div style="border: 1px solid black; border-radius: 50%; width: 40px; height: 40px; display: flex; align-items: center; justify-content: center; margin-right: 10px;">2</div> <div style="border: 1px solid black; border-radius: 50%; width: 40px; height: 40px; display: flex; align-items: center; justify-content: center;">DOWN</div> </div> <div style="display: flex; align-items: center; margin-bottom: 10px;"> <div style="border: 1px solid black; border-radius: 50%; width: 40px; height: 40px; display: flex; align-items: center; justify-content: center; margin-right: 10px;">5</div> <div style="border: 1px solid black; border-radius: 50%; width: 40px; height: 40px; display: flex; align-items: center; justify-content: center;">EAST</div> </div> <div style="display: flex; align-items: center; margin-bottom: 10px;"> <div style="border: 1px solid black; border-radius: 50%; width: 40px; height: 40px; display: flex; align-items: center; justify-content: center; margin-right: 10px;">6</div> <div style="border: 1px solid black; border-radius: 50%; width: 40px; height: 40px; display: flex; align-items: center; justify-content: center;">WEST</div> </div> <div style="display: flex; align-items: center; margin-bottom: 10px;"> <div style="border: 1px solid black; border-radius: 50%; width: 40px; height: 40px; display: flex; align-items: center; justify-content: center; margin-right: 10px;"></div> <div style="border: 1px solid black; border-radius: 50%; width: 40px; height: 40px; display: flex; align-items: center; justify-content: center;">SOUTH</div> </div> <div style="display: flex; align-items: center;"> <div style="border: 1px solid black; border-radius: 50%; width: 40px; height: 40px; display: flex; align-items: center; justify-content: center; margin-right: 10px;"></div> <div style="border: 1px solid black; border-radius: 50%; width: 40px; height: 40px; display: flex; align-items: center; justify-content: center;">NORTH</div> </div> </div>
<div style="border: 1px solid black; padding: 5px; margin-bottom: 5px;"> <div style="border: 1px solid black; width: 100%; height: 100%; display: flex; flex-direction: column; align-items: center; justify-content: center;"> <div style="border: 1px solid black; width: 100%; height: 20px; margin-bottom: 5px;"></div> <div style="border: 1px solid black; width: 100%; height: 20px; margin-bottom: 5px;"></div> <div style="border: 1px solid black; width: 100%; height: 20px;"></div> </div> <p style="text-align: center;"><b>normal, not interlocked</b></p> <p> <input type="radio"/> normal, interlocked with button "2"  <input type="radio"/> toggle (on/off)  <input type="radio"/> on (off is button 2)         </p> </div> <div style="border: 1px solid black; padding: 5px; margin-bottom: 5px;"> <div style="border: 1px solid black; width: 100%; height: 100%; display: flex; flex-direction: column; align-items: center; justify-content: center;"> <div style="border: 1px solid black; width: 100%; height: 20px; margin-bottom: 5px;"></div> <div style="border: 1px solid black; width: 100%; height: 20px; margin-bottom: 5px;"></div> <div style="border: 1px solid black; width: 100%; height: 20px;"></div> </div> <p style="text-align: center;"><b>normal, not interlocked</b></p> <p> <input type="radio"/> normal, interlocked with button "1"  <input type="radio"/> toggle (on/off)  <input type="radio"/> off (on is button "1")         </p> </div> <div style="border: 1px solid black; padding: 5px; margin-bottom: 5px;"> <div style="border: 1px solid black; width: 100%; height: 100%; display: flex; flex-direction: column; align-items: center; justify-content: center;"> <div style="border: 1px solid black; width: 100%; height: 20px; margin-bottom: 5px;"></div> <div style="border: 1px solid black; width: 100%; height: 20px; margin-bottom: 5px;"></div> <div style="border: 1px solid black; width: 100%; height: 20px;"></div> </div> <p style="text-align: center;"><b>normal, not interlocked</b></p> <p> <input type="radio"/> toggle (on/off)  <input type="radio"/> ratchet up  <input type="radio"/> inching .1 seconds  <input type="radio"/> inching .2 seconds  <input type="radio"/> inching .3 seconds  <input type="radio"/> inching .4 seconds  <input type="radio"/> inching .5 seconds         </p> </div> <div style="border: 1px solid black; padding: 5px;"> <div style="border: 1px solid black; width: 100%; height: 100%; display: flex; flex-direction: column; align-items: center; justify-content: center;"> <div style="border: 1px solid black; width: 100%; height: 20px; margin-bottom: 5px;"></div> <div style="border: 1px solid black; width: 100%; height: 20px; margin-bottom: 5px;"></div> <div style="border: 1px solid black; width: 100%; height: 20px;"></div> </div> <p style="text-align: center;"><b>normal, not interlocked</b></p> <p> <input type="radio"/> toggle (on/off)  <input type="radio"/> ratchet down         </p> </div>	<div style="border: 1px solid black; padding: 5px; margin-bottom: 5px;"> <div style="border: 1px solid black; width: 100%; height: 100%; display: flex; flex-direction: column; align-items: center; justify-content: center;"> <div style="border: 1px solid black; width: 100%; height: 20px; margin-bottom: 5px;"></div> <div style="border: 1px solid black; width: 100%; height: 20px; margin-bottom: 5px;"></div> <div style="border: 1px solid black; width: 100%; height: 20px;"></div> </div> <p style="text-align: center;"><b>normal, interlocked with button "DOWN"</b></p> <p> <input type="radio"/> normal, not interlocked  <input type="radio"/> toggle (on/off)  <input type="radio"/> on (off is button "DOWN")         </p> </div> <div style="border: 1px solid black; padding: 5px; margin-bottom: 5px;"> <div style="border: 1px solid black; width: 100%; height: 100%; display: flex; flex-direction: column; align-items: center; justify-content: center;"> <div style="border: 1px solid black; width: 100%; height: 20px; margin-bottom: 5px;"></div> <div style="border: 1px solid black; width: 100%; height: 20px; margin-bottom: 5px;"></div> <div style="border: 1px solid black; width: 100%; height: 20px;"></div> </div> <p style="text-align: center;"><b>normal, interlocked with button "UP"</b></p> <p> <input type="radio"/> normal, not interlocked  <input type="radio"/> toggle (on/off)  <input type="radio"/> off (on is button "UP")         </p> </div> <div style="border: 1px solid black; padding: 5px; margin-bottom: 5px;"> <div style="border: 1px solid black; width: 100%; height: 100%; display: flex; flex-direction: column; align-items: center; justify-content: center;"> <div style="border: 1px solid black; width: 100%; height: 20px; margin-bottom: 5px;"></div> <div style="border: 1px solid black; width: 100%; height: 20px; margin-bottom: 5px;"></div> <div style="border: 1px solid black; width: 100%; height: 20px;"></div> </div> <p style="text-align: center;"><b>normal, interlocked with button "WEST"</b></p> <p> <input type="radio"/> normal, not interlocked  <input type="radio"/> toggle (on/off)  <input type="radio"/> on (off is button "WEST")         </p> </div> <div style="border: 1px solid black; padding: 5px; margin-bottom: 5px;"> <div style="border: 1px solid black; width: 100%; height: 100%; display: flex; flex-direction: column; align-items: center; justify-content: center;"> <div style="border: 1px solid black; width: 100%; height: 20px; margin-bottom: 5px;"></div> <div style="border: 1px solid black; width: 100%; height: 20px; margin-bottom: 5px;"></div> <div style="border: 1px solid black; width: 100%; height: 20px;"></div> </div> <p style="text-align: center;"><b>normal, interlocked with button "EAST"</b></p> <p> <input type="radio"/> normal, not interlocked  <input type="radio"/> toggle (on/off)  <input type="radio"/> off (on is button "EAST")         </p> </div> <div style="border: 1px solid black; padding: 5px; margin-bottom: 5px;"> <div style="border: 1px solid black; width: 100%; height: 100%; display: flex; flex-direction: column; align-items: center; justify-content: center;"> <div style="border: 1px solid black; width: 100%; height: 20px; margin-bottom: 5px;"></div> <div style="border: 1px solid black; width: 100%; height: 20px; margin-bottom: 5px;"></div> <div style="border: 1px solid black; width: 100%; height: 20px;"></div> </div> <p style="text-align: center;"><b>normal, interlocked with button "NORTH"</b></p> <p> <input type="radio"/> normal, not interlocked  <input type="radio"/> toggle (on/off)  <input type="radio"/> on (off is button "NORTH")         </p> </div> <div style="border: 1px solid black; padding: 5px;"> <div style="border: 1px solid black; width: 100%; height: 100%; display: flex; flex-direction: column; align-items: center; justify-content: center;"> <div style="border: 1px solid black; width: 100%; height: 20px; margin-bottom: 5px;"></div> <div style="border: 1px solid black; width: 100%; height: 20px; margin-bottom: 5px;"></div> <div style="border: 1px solid black; width: 100%; height: 20px;"></div> </div> <p style="text-align: center;"><b>normal, interlocked with button "SOUTH"</b></p> <p> <input type="radio"/> normal, not interlocked  <input type="radio"/> toggle (on/off)  <input type="radio"/> off (on is button "SOUTH")         </p> </div>	
<p><b>Second function of START position</b>  <b>Sound Alarm</b></p> <p> <input type="radio"/> Close RØ momentary  <input type="radio"/> Close RØ toggle         </p>	<p style="text-align: center;"><b>Auto Shut Down time</b>  <b>Default setting of 1 hour</b></p> <p> <input type="radio"/> never  <input type="radio"/> 10 minutes  <input type="radio"/> 20 minutes  <input type="radio"/> 30 minutes  <input type="radio"/> 1 hour  <input type="radio"/> 2 hours  <input type="radio"/> 3 hours  <input type="radio"/> 4 hours         </p>	

## Technical Sheet: F22-J

### General Specifications

**Typical application:** Multiple motion, multiple speed applications with numerous extra functions.

**Operating Distance:** 500+feet

**Frequency:** 450Mhz band

**Number of available frequencies:** 256

**Frequency generation:** Synthesized phase lock loop.

**Security coding:** 65,000 unique security codes available.

**Environment rating:** Outdoor use, IP65

**Licensing:** FCC certified, no license needed.

**Warranty:** 1 year, see manual

**Temperature Rating:** -35 to +75°C

#### Receiver mounting

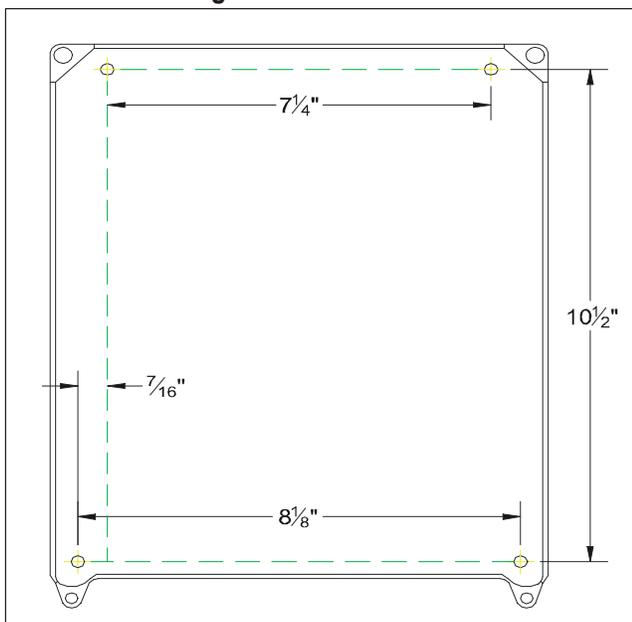

### Receiver Specifications

**Size:** 14.25" x 11" x 4.5" not including antenna or cables

**Receiver Part #** F22-J-RX

**Power supply input:** 120VAC-240VAC (auto adjusting)

**Relay ratings:** 5amp/250VAC

**Error notification:** audible Morse Code via horn

**Weight:** 12.5 lbs.

**Includes:** Loud horn, large mainline indicator, emergency stop disconnect button. Totally pre-cabled.

**Accessories available:** Extended antenna kit for mounting receiver inside cabinets or mounting antenna in better position for reception.

**Physical mounting specifications below**

### Transmitter Specifications

**Transmitter Part #:** F22-J-TX

**Transmitters:** 2 supplied standard.

**Size:** 8.5" x 4.25" x 4.25"

**Weight:** 2.3 pounds including batteries

**Material:** Fiber reinforced nylon

**Power source:** 4 AA alkaline batteries.

**Battery power indication:** LED and audible alarm.

**Joysticks:** 2 joysticks operating a total of 4 axis motions. Full 360 degree range of motion. Rated for 10 million cycles. See Joystick relay customization and label customization sheets.

**Dials:** 2 on/off dials and 2 A,B dials. See programming and custom labeling sheet.

**Buttons:** 6 programmable, 2 step, plus start and stop. Rated to 2 million cycles. See programming and custom labeling sheet.

**Start key:** removable

**Stop Button:** mushroom style

**Error notification:** audible Morse Code via buzzer

**Includes:** shoulder strap and 4 AA batteries.



## Receiver Schematic: F22-J

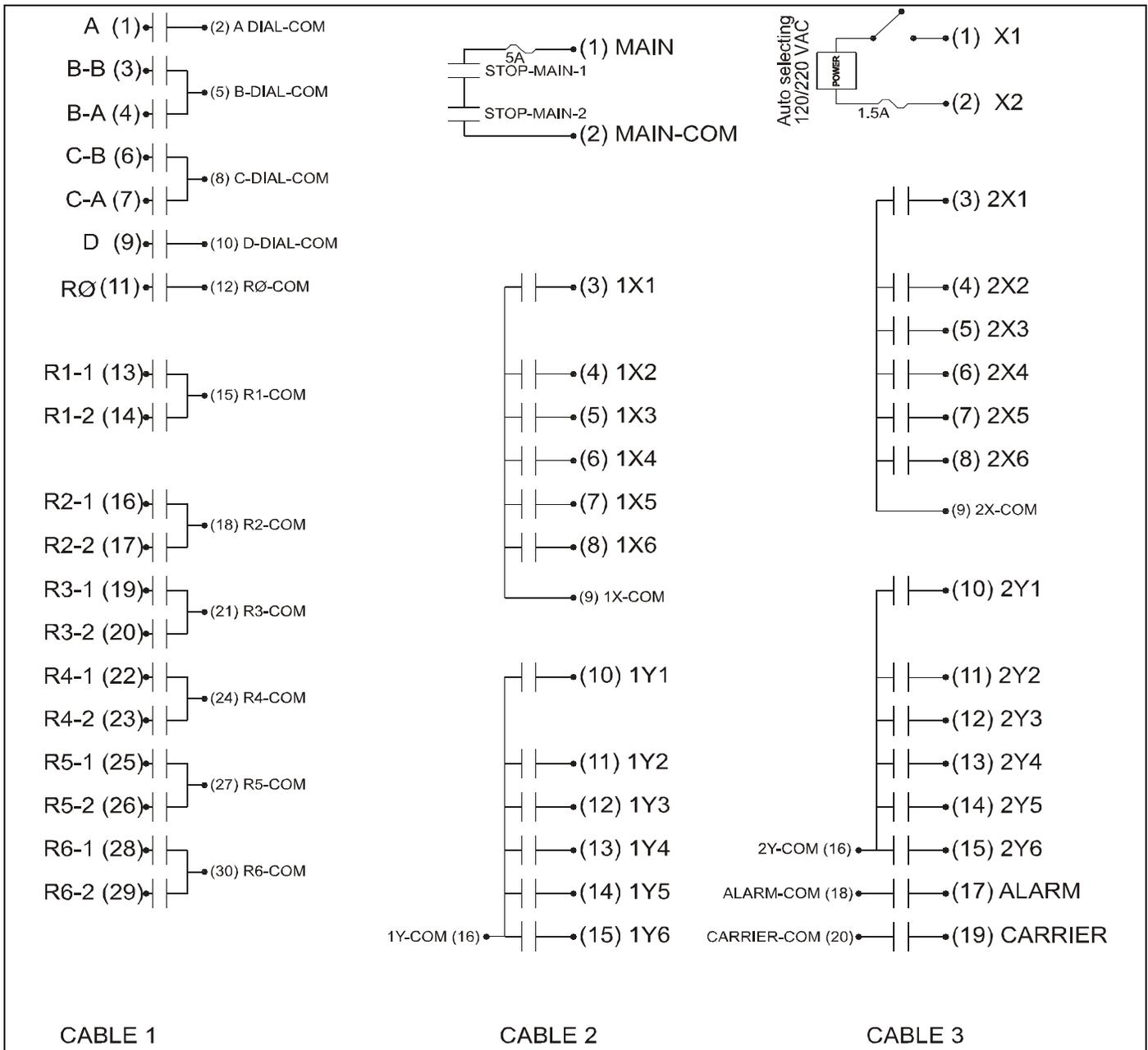



## Buttons and Dials Programming Sheet: F22-J

**normal, interlocked with button "2"**

normal, not interlocked

toggle (on/off)

on (off is button "2")

specific, for dual motors systems

**normal interlocked with button "4"**

normal, not interlocked

toggle (on/off)

on (off is button "4")

**normal, interlocked with button "6"**

normal, not interlocked

toggle (on/off)

on (off is button "6")

**Auto Shut Down time**  
Default setting of 1 hour

never       1 hour

10 minutes       2 hours

20 minutes       3 hours

30 minutes       4 hours

**normal, interlocked with button "1"**

normal, not interlocked

toggle (on/off)

off (on is button "1")

specific, for dual motors systems

**normal interlocked with button "3"**

normal, not interlocked

toggle (on/off)

off (on is button "3")

**normal, interlocked with button "5"**

normal, not interlocked

toggle (on/off)

off (on is button "5")

**Acceleration delay for all button relays.**  
Default setting of ZERO

.3 seconds       2.9 seconds

.5 seconds       3 seconds

.8 seconds       3.1 seconds

1 second       3.4 seconds

2 seconds       3.7 seconds

2.1 seconds       3.9 seconds

2.4 seconds       5 seconds

2.6 seconds

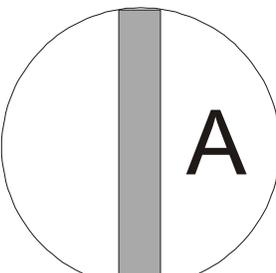

A

--	--	--	--	--

On / Off

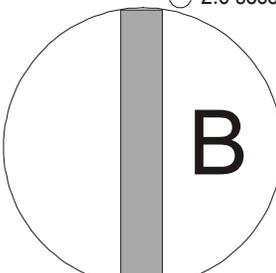

B

--	--	--	--	--

A, A+B, B

A, OFF, B

The A & B associated with dial B has nothing to do with the A & B associated with dial C.

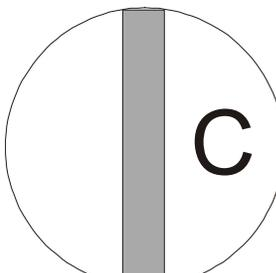

C

--	--	--	--	--

A, A+B, B

A, OFF, B

The A & B associated with dial C has nothing to do with the A & B associated with dial B.

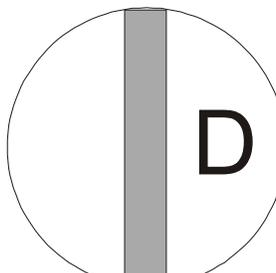

D

--	--	--	--	--

On / Off

**Second function of START position**  
**Sound Alarm**

Close RØ momentary

Close RØ toggle

**THIS PAGE INTENTIONALLY LEFT BLANK**

## Joystick Programming Sheet: F22-J

### Custom labels for F22-J

The words in bold appear on the joystick motion if you do not fill in the squares below.

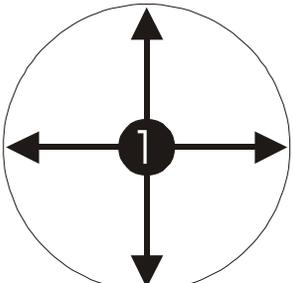
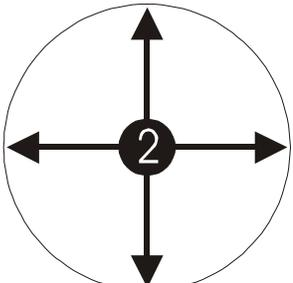
<b>WEST</b> <input type="text"/> <input type="text"/> <input type="text"/> <input type="text"/> <input type="text"/> <input type="text"/>	<b>EAST</b> <input type="text"/> <input type="text"/> <input type="text"/> <input type="text"/> <input type="text"/> <input type="text"/>	<b>aux DOWN</b> <input type="text"/> <input type="text"/> <input type="text"/> <input type="text"/> <input type="text"/> <input type="text"/>	<b>aux UP</b> <input type="text"/> <input type="text"/> <input type="text"/> <input type="text"/> <input type="text"/> <input type="text"/>
	<b>NORTH</b> <input type="text"/> <input type="text"/> <input type="text"/> <input type="text"/> <input type="text"/> <input type="text"/> <b>SOUTH</b> <input type="text"/> <input type="text"/> <input type="text"/> <input type="text"/> <input type="text"/> <input type="text"/>		<b>UP</b> <input type="text"/> <input type="text"/> <input type="text"/> <input type="text"/> <input type="text"/> <input type="text"/> <b>DOWN</b> <input type="text"/> <input type="text"/> <input type="text"/> <input type="text"/> <input type="text"/> <input type="text"/>

### Restrict maximum speed position of any motion

Circle the last detent that the that motion can achieve. Default detent is all the way through to the 5th step.

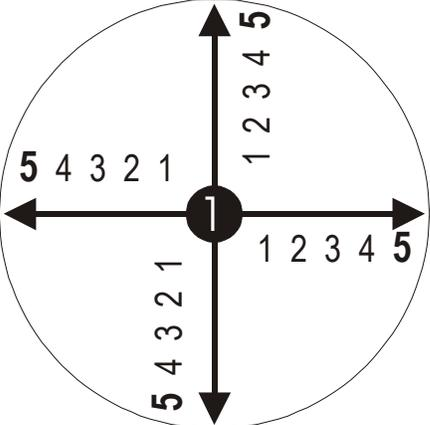
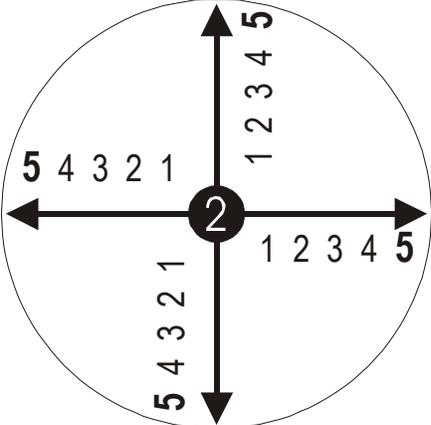
	<p>If you wish to eliminate all the detents from any of the 4 motions write <b>NO DETENTS</b> above the motion's arrow.</p> 
--	--

### Customize travel path of joystick

To customize where the joystick can travel circle one of the drawings below for each joystick or fill in the blank circle with the path desired. The fully black circle represents the default setting of complete 360 degree range of motion.

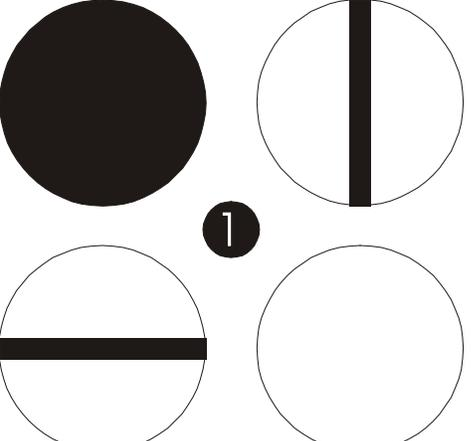
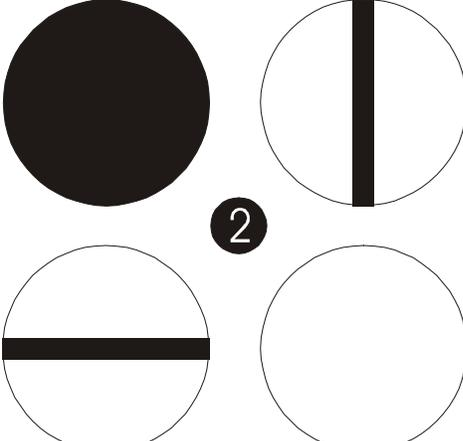
<p><b>1</b></p> 	<p><b>2</b></p> 
---	---

**THIS PAGE INTENTIONALLY LEFT BLANK**

# Custom relay configuration sheet for model: F22-J

## Standard Configurations

## Custom Configurations

	WEST					EAST					
	5	4	3	2	1	0	1	2	3	4	5
1X1	X	X	X	X	X						
1X2						X	X	X	X	X	X
1X3	X	X	X	X				X	X	X	X
1X4	X	X	X						X	X	X
1X5	X	X								X	X
1X6	X										X

	WEST					EAST					
	5	4	3	2	1	0	1	2	3	4	5
1X1											
1X2											
1X3											
1X4											
1X5											
1X6											

Acceleration delay in seconds: 0.0, 0.3, 0.5, 0.8, 1.0, 1.3, 1.6, 1.8, 2.1, 2.4, 2.6, 2.9, 3.1, 3.4, 3.7, 3.9

	OUTH					NORTH					
	5	4	3	2	1	0	1	2	3	4	5
1Y1	X	X	X	X	X						
1Y2						X	X	X	X	X	X
1Y3	X	X	X	X				X	X	X	X
1Y4	X	X	X						X	X	X
1Y5	X	X								X	X
1Y6	X										X

	SOUTH					NORTH					
	5	4	3	2	1	0	1	2	3	4	5
1Y1											
1Y2											
1Y3											
1Y4											
1Y5											
1Y6											

Acceleration delay in second : 0.0, 0.3, 0.5, 0.8, 1.0, 1.3, 1.6, 1.8, 2.1, 2.4, 2.6, 2.9, 3.1, 3.4, 3.7, 3.9

	AUX DOWN					AUX UP					
	5	4	3	2	1	0	1	2	3	4	5
2X1	X	X	X	X	X						
2X2						X	X	X	X	X	X
2X3	X	X	X	X				X	X	X	X
2X4	X	X	X						X	X	X
2X5	X	X								X	X
2X6	X										X

	AUX DOWN					AUX UP					
	5	4	3	2	1	0	1	2	3	4	5
2X1											
2X2											
2X3											
2X4											
2X5											
2X6											

Acceleration delay in seconds: 0.0, 0.3, 0.5, 0.8, 1.0, 1.3, 1.6, 1.8, 2.1, 2.4, 2.6, 2.9, 3.1, 3.4, 3.7, 3.9

	DOWN					UP					
	5	4	3	2	1	0	1	2	3	4	5
2Y1	X	X	X	X	X						
2Y2						X	X	X	X	X	X
2Y3	X	X	X	X				X	X	X	X
2Y4	X	X	X						X	X	X
2Y5	X	X								X	X
2Y6	X										X

	DOWN					UP					
	5	4	3	2	1	0	1	2	3	4	5
2Y1											
2Y2											
2Y3											
2Y4											
2Y5											
2Y6											

Acceleration delay in seconds : 0.0, 0.3, 0.5, 0.8, 1.0, 1.3, 1.6, 1.8, 2.1, 2.4, 2.6, 2.9, 3.1, 3.4, 3.7, 3.9

Notes:

\*The default relay configuration chart is on the left side. If you want the relays to close in different combinations than the default settings then mark the appropriate chart to the right with X's in the appropriate squares.

\*The acceleration delay time default for all joystick motions is set for 1/2 second. If you would like any of the axes' acceleration delay time changed circle the new time.