

CS40

Mobile Computer



User's Manual

Intermec Technologies Corporation

Worldwide Headquarters

6001 36th Ave.W.

Everett, WA 98203

U.S.A.

www.intermec.com

The information contained herein is provided solely for the purpose of allowing customers to operate and service Intermec-manufactured equipment and is not to be released, reproduced, or used for any other purpose without written permission of Intermec Technologies Corporation.

Information and specifications contained in this document are subject to change without prior notice and do not represent a commitment on the part of Intermec Technologies Corporation.

© 2010 by Intermec Technologies Corporation. All rights reserved.

The word Intermec, the Intermec logo, Norand, ArciTech, Beverage Routebook, CrossBar, dcBrowser, Duratherm, EasyADC, EasyCoder, EasySet, Fingerprint, i-gistics, INCA (under license), Intellitag, Intellitag Gen2, JANUS, LabelShop, MobileLAN, Picolink, Ready-to-Work, RoutePower, Sabre, ScanPlus, ShopScan, Smart Mobile Computing, SmartSystems, TE 2000, Trakker Antares, and Vista Powered are either trademarks or registered trademarks of Intermec Technologies Corporation.

There are U.S. and foreign patents as well as U.S. and foreign patents pending.

Contents

Before You Begin.....	vii
Safety Information.....	vii
Global Services and Support.....	vii
Warranty Information.....	vii
Web Support.....	viii
Telephone Support.....	viii
Service Location Support.....	viii
Who Should Read This Manual.....	ix
Related Documents.....	ix
Patent Information.....	x

1 Using the CS40.....	1
About the CS40 Mobile Computer.....	2
Overview of CS40 Features.....	3
CS40 Accessories.....	3
About the CS40 Battery.....	4
Charging the Battery.....	4
Replacing the Battery.....	5
About Battery Status.....	6
About Battery Life and Conservation.....	7
About the Keypad.....	8
About the Power Button.....	8
Entering Characters on the QWERTY Keypad.....	9
Entering Characters on the Numeric Keypad.....	9
Adjusting the Volume.....	10
Configuring Backlight Settings.....	11
About the Status LEDs.....	12
About the Imager.....	13
About Bar Codes.....	13
Reading Bar Codes.....	13
About Signature Capture.....	15

Contents

About the Color Camera.....	15
Taking a Picture	16
Recording Video	16
Saving Pictures and Videos to an SD Card.....	17
Inserting a microSD Card.....	17
How to Enable the Integrated GPS on the CS40	18
Using the GPSID Installed on the CS40.....	19
Improving GPS Performance on the CS40.....	20
About Additional GPS Options for the Computer	21
2 Connecting and Configuring the CS40	23
How to Configure the CS40.....	24
About SmartSystems Foundation	24
How to Connect the CS40 to a PC	25
How to Connect the CS40 to Your Network	25
Connecting the CS40 Using 802.11 Radio Communications.....	26
Connecting the CS40 Using Bluetooth Communications.....	27
Connecting the CS40 to a Wireless Printer	28
Connecting the CS40 Using Ethernet Communications	29
Connecting the CS40 Using USB Communications	30
About the Phone.....	30
Turning On the Phone Using the Wireless Manager.....	31
Activating the UMTS Radio.....	31
Making a Phone Call	32
Connecting to an ISP.....	32
Connecting to a Network With a VPN Server	34
3 Developing and Installing Applications	35
How to Develop Applications for the CS40	36
How to Package Your Application	36
How to Choose a Target Location	36

How to Install Applications on the CS40	37
Installing Applications Using SmartSystems Foundation Console.	37
Installing Applications Using Microsoft ActiveSync or Windows Mobile Device Center.	38
How to Install Applications Using a Scan-to-Connect Bar Code	38
Installing Applications Using a microSD Card.	38
How to Update the System Software	39
Updating Multiple CS40s Using SmartSystems Console.	40
How to Send Silent Update Packages to the Computer	41
Updating Individual CS40s	41
4 Troubleshooting and Maintaining the Computer	43
Calling Product Support.	44
Troubleshooting the Computer	45
Resetting the Computer	50
Warm Booting the Computer	50
Cold Booting the Computer	50
Clean Booting the Computer	51
Cleaning the Computer.	52
A Specifications	53
Physical and Environmental Specifications.	54
CS40 Micro-AB USB Connector Specifications	58
CS40 Docking Connector Specifications	58
EA11 Imager Reading Distances.	56
B Default Settings	59
Default Configuration	60
C Keypads and Keystrokes	65
Standard Characters	66

D Imager Configuration Bar Codes 71

 Imager Configuration Bar Codes 72

Before You Begin

This section provides you with safety information, technical support information, and sources for additional product information.

Safety Information

Your safety is extremely important. Read and follow all warnings and cautions in this document before handling and operating Intermec equipment. You can be seriously injured, and equipment and data can be damaged if you do not follow the safety warnings and cautions.

This section explains how to identify and understand warnings, cautions, and notes that are in this document.



A warning alerts you of an operating procedure, practice, condition, or statement that must be strictly observed to avoid death or serious injury to the persons working on the equipment.



A caution alerts you to an operating procedure, practice, condition, or statement that must be strictly observed to prevent equipment damage or destruction, or corruption or loss of data.



Note: Notes either provide extra information about a topic or contain special instructions for handling a particular condition or set of circumstances.

Global Services and Support

Warranty Information

To understand the warranty for your Intermec product, visit the Intermec web site at www.intermec.com and click **Support > Returns and Repairs > Warranty**.

Disclaimer of warranties: The sample code included in this document is presented for reference only. The code does not necessarily represent complete, tested programs. The code is provided “as is with all faults.” All warranties are expressly disclaimed, including the implied warranties of merchantability and fitness for a particular purpose.

Web Support

Visit the Intermec web site at www.intermec.com to download our current manuals (in PDF). To order printed versions of the Intermec manuals, contact your local Intermec representative or distributor.

Visit the Intermec technical knowledge base (Knowledge Central) at www.intermec.com and click **Support > Knowledge Central** to review technical information or to request technical support for your Intermec product.

Telephone Support

In the U.S.A. and Canada, call **1-800-755-5505**.

Outside the U.S.A. and Canada, contact your local Intermec representative. To search for your local representative, from the Intermec web site, click **About Us > Contact Us**.

Service Location Support

For the most current listing of service locations, click **Support > Returns and Repairs > Repair Locations**.

For technical support in South Korea, use the after service locations listed below:

AWOO Systems

102-1304 SK Ventium

522 Dangjung-dong

Gunpo-si, Gyeonggi-do Korea, South 435-776

Contact: Mr. Sinbum Kang

Telephone: +82-31-436-1191

Email: mjyun@awoo.co.kr

IN Information System PTD LTD

6th Floor

Daegu Venture Center Bldg 95

Shinchun 3 Dong

Donggu, Daegu City, Korea

E-mail: jmyou@idif.co.kr or korlim@gw.idif.co.kr

Who Should Read This Manual

This manual is written for the person who is responsible for installing, configuring, and maintaining the CS40 Mobile Computer.

This manual provides you with information about the features of the CS40, and how to install, configure, operate, maintain, and troubleshoot it.

Before you work with the CS40, you should be familiar with your network and general networking terms, such as IP address.

Related Documents

You may find these related software and programming documents useful:

- *Intermec Settings Command Reference Manual*
- *Intermec Developer Library (IDL) Resource Kit Developer's Guide*
- *Intermec Browser User's Manual*
- *Intermec Launcher User's Manual*
- *Intermec Connection Manager User's Guide*

The Intermec web site at www.intermec.com contains our documents (as PDF files) that you can download for free.

To download documents

- 1 Visit the Intermec web site at www.intermec.com.
- 2 Click the **Products** tab.
- 3 Using the **Products** menu, navigate to your product page. For example, to find the CS40 computer product page, click **Computers > Handheld Computers > CS40**.
- 4 Click the **Manuals** tab.

If your product does not have its own product page, click **Support > Manuals**. Use the **Product Category** field, the **Product Family** field, and the **Product** field to help you locate the documentation for your product.

Patent Information

Product is covered by one or more of the following patents:

5,155,659; 5,243,602; 5,278,487; 5,289,378; 5,305,181; 5,308,966;
5,317,691; 5,319,184; 5,322,991; 5,324,925; 5,327,308; 5,331,580;
5,342,210; 5,345,146; 5,347,115; 5,349,497; 5,349,678; 5,359,185;
5,362,953; 5,363,031; 5,371,858; 5,389,770; 5,397,885; 5,401,591;
5,401,592; 5,404,493; 5,408,382; 5,410,141; 5,413,529; 5,414,251;
5,416,463; 5,440,315; 5,442,167; 5,457,629; 5,463,305; 5,464,972;
5,465,207; 5,466,170; 5,468,945; 5,468,947; 5,468,948; 5,468,950;
5,473,242; 5,477,044; 5,486,689; 5,487,161; 5,493,199; 5,500,516;
5,502,297; 5,504,367; 5,510,589; 5,514,858; 5,515,215; 5,517,373;
5,517,434; 5,521,370; 5,534,684; 5,536,124; 5,536,924; 5,539,191;
5,541,419; 5,544,010; 5,548,108; 5,548,201; 5,550,362; 5,550,364;
5,553,084; 5,554,822; 5,555,459; 5,557,092; 5,563,748; 5,565,669;
5,568,016; 5,568,645; 5,576,529; 5,576,601; 5,576,981; 5,587,577;
5,598,007; 5,598,082; 5,608,578; 5,616,909; 5,625,555; 5,627,360;
5,630,090; 5,631,539; 5,640,001; 5,644,471; 5,659,431; 5,671,436;
5,672,860; 5,682,299; 5,684,290; 5,694,318; 5,710,728; 5,714,812;
5,717,313; 5,719,678; 5,726,937; 5,733,673; 5,736,725; 5,747,785;
5,747,938; 5,764,798; 5,773,159; 5,777,309; 5,780,992; 5,786,583;
5,795,664; 5,796,359; 5,798,513; 5,798,610; 5,802,379; 5,805,416;
5,805,474; 5,811,776; 5,811,777; 5,811,828; 5,818,027; 5,818,199;
5,821,523; 5,828,052; 5,834,749; 5,834,753; 5,834,760; 5,838,471;
5,841,402; 5,841,403; 5,842,070; 5,844,222; 5,854,478; 5,856,737;
5,862,267; 5,869,840; 5,872,354; 5,873,070; 5,877,486; 5,878,395;
5,886,338; 5,889,818; 5,892,971; 5,895,906; 5,896,214; 5,898,290;
5,902,987; 5,902,988; 5,912,452; 5,912,547; 5,914,585; 5,923,022;
5,936,224; 5,939,700; 5,943,421; 5,961,337; 5,969,326; 5,969,328;
5,969,502; 5,973,645; 5,979,768; 5,987,192; 5,987,499; 5,992,750;
5,992,751; 5,996,080; 5,996,896; 6,003,773; 6,003,775; 6,012,638;
6,012,640; 6,012,939; 6,016,960; 6,018,597; 6,024,289; 6,026,027;
6,031,524; 6,034,379; 6,036,093; 6,037,919; 6,039,252; 6,039,258;
6,042,414; 6,049,813; 6,052,279; 6,053,759; 6,058,000; 6,061,155;
6,064,763; 6,076,731; 6,091,227; 6,094,029; 6,095,422; 6,097,839;
6,102,266; 6,102,289; 6,102,295; 6,109,528; 6,112,206; 6,113,047;
6,119,941; 6,124,800; 6,128,414; 6,131,815; 6,135,810; 6,137,260;
6,149,059; 6,149,061; 6,149,063; 6,152,370; 6,155,490; 6,158,661;
6,161,123; 6,163,359; 6,164,542; 6,164,545; 6,173,893; 6,174,180;

6,177,926; 6,186,406; 6,199,044; 6,204,632; 6,204,825; 6,212,401;
6,213,400; 6,229,408; 6,234,393; 6,234,395; 6,236,186; 6,236,486;
6,243,258; 6,249,008; 6,259,044; 6,292,437; 6,295,461; 6,307,349;
6,321,986; 6,328,214; 6,330,972; 6,330,974; 6,330,975; 6,345,765;
6,356,949; 6,367,699; 6,375,076; 6,398,105; 6,404,325; 6,435,411;
6,478,223; 6,484,944; 6,488,209; 6,497,368; 6,532,152; 6,538,413;
6,539,064; 6,539,422; 6,641,046; 6,669,087; 6,687,403; 6,691,922;
6,694,359; 6,701,361; 6,724,510; 6,731,713; 6,732,930; 6,776,342;
6,857,013; 6,879,428; 6,897,776; 6,944,446; 6,967,280; 6,970,459;
6,976,062; 7,027,037; 7,034,659; 7,035,466; 7,090,137; 7,095,383;
7,117,374; 7,125,743; 7,139,870; 7,143,941; 7,152,797; 7,159,764;
7,180,640; 7,184,068; 7,185,819; 7,190,835; 7,206,338; 7,208,916;
7,210,633; 7,232,072; 7,249,302; 7,271,679; 7,296,749; 7,298,791;
7,325,741; 7,327,988; 7,347,375; 7,360,705; 7,392,951; 7,407,105;
7,411,501; 7,412,097; 7,413,125; 7,417,809; 7,418,157; 7,427,912;
7,444,516; 7,451,441; 7,451,931; 7,451,933

There may be other U.S. and foreign patents pending.

Before You Begin

1

Using the CS40

This chapter introduces the CS40 Mobile Computer with Windows® Mobile® 6.5 and describes the basic features of the computer. This chapter contains these topics:

- **About the CS40 Mobile Computer**
- **Overview of CS40 Features**
- **CS40 Accessories**
- **About the CS40 Battery**
- **About the Keypad**
- **Adjusting the Volume**
- **Configuring Backlight Settings**
- **About the Status LEDs**
- **About the Imager**
- **About Bar Codes**
- **About the Color Camera**
- **Inserting a microSD Card**
- **How to Enable the Integrated GPS on the CS40**

About the CS40 Mobile Computer

The Intermec CS40 Mobile Computer is a small, lightweight mobile computer built on the Microsoft® Windows® Mobile 6.5 operating system. This Personal Digital Assistant PDA-style mobile computer supports the latest High Speed Uplink Packet Access (HSUPA).

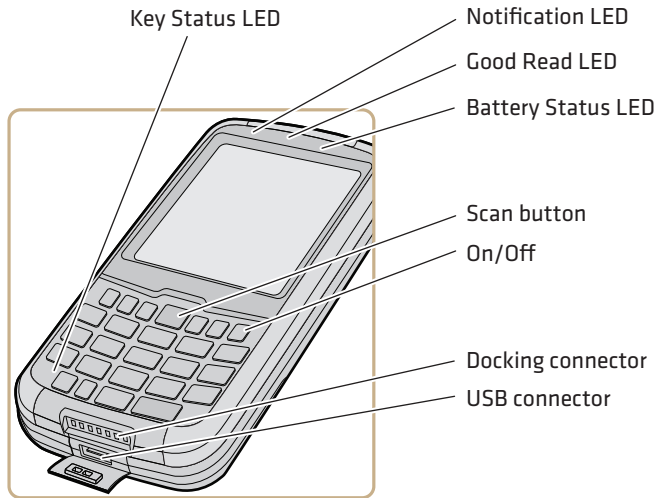

CS40 Front View

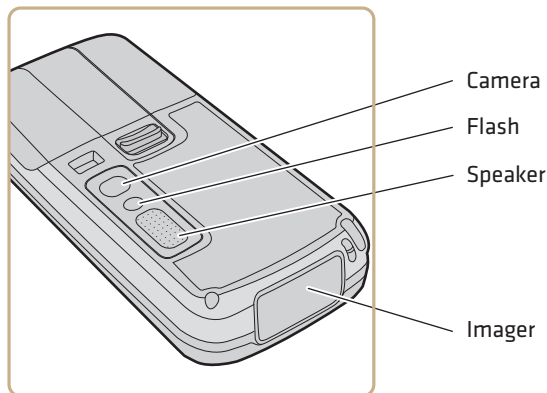

CS40 Back View

Overview of CS40 Features

The CS40 includes these standard features:

- EA11 area imager that can read bar codes and capture signatures
- Multi-processor architecture with 256 MB DRAM and 512 MB Flash (approximately 350 MB free for custom applications)
- 3.75G UMTS (with EDGE, GPRS, and GSM fallback), 802.11b/g, and Bluetooth® radio
- Integrated GPS receiver
- 3-megapixel color camera
- Customer-accessible micro-SD slot for removable memory cards up to 32 GB
- Customer-accessible SIM card slot
- Numeric or QWERTY keypad



The CS40 Mobile Computer with an IEEE 802.11b/g radio installed is Wi-Fi® certified for interoperability with other 802.11b/g wireless LAN devices.

CS40 Accessories

The CS40 accessories are sold and ordered separately. For help, contact your local Intermec sales representative.

CS40 Accessories

Accessory	Description
CS40 Battery (Model 1005AB01)	The battery provides main power to the CS40.
Universal Cell Phone Charger	Use the universal cell phone charger to provide power to your CS40 from an external power supply.
DX1 Desktop Dock (Model 1002UU02)	Use the desktop dock with the: <ul style="list-style-type: none"> • CS40 cup (Model 1002UC06) to charge the battery while it is installed in the CS40. • CS40 battery cup (Model 1002UC05) to charge the battery.

CS40 Accessories (continued)

Accessory	Description
DX2 Dual Base (Model 1002UU01) and DX4 Quad Base (Model 1002UU03)	Use these charger bases with the: <ul style="list-style-type: none">• CS40 cup (Model 1002UC06) to charge two or four batteries while they are installed in the CS40.• CS40 battery cup (Model 1002UC05) to charge two or four batteries.
Vehicle Power Adapter (Model 9005AX01)	Use the vehicle power adapter to provide power to the CS40 from your vehicle.
Power and Data Y-Cable	Use the power and data y-cable to provide power to your CS40 from an external power supply and provide USB communications with your PC.
Vehicle Holder	Use the vehicle holder to hold your CS40 while you are using it in a vehicle.
Holster and Purse Holster	Use the holster accessories to carry your CS40 when you are not using it.

About the CS40 Battery

The CS40 uses a battery pack (Model 1005AB01) as its main power source.



The battery used in this device may present a fire or chemical burn hazard if it is mistreated. Do not disassemble it, heat it above 100°C (212°F) or incinerate it. Dispose of used batteries promptly. Keep away from children.



Note: If the CS40 is not using external power and you remove the battery pack, the CS40 goes into a power off state and then cold boots.

Charging the Battery

You need to fully charge the battery before using your CS40 for the first time.

To charge the battery

- Use one of the charging accessories listed in the next table.

Charging Times for the CS40 Battery

Accessory	Charging Time
Universal cell phone charger	4 hours
DX1 desktop dock and CS40 cup	6 hours
DX1 desktop dock and CS40 battery cup	6 hours
DX2 or DX4 base and CS40 cup	6 hours
DX2 or DX4 base and CS40 battery cup	6 hours
Vehicle power adapter	
Data and power y-cable	variable*

* When you charge your CS40 from your PC, the charge time depends on the amount of power provided by the USB port on your PC.

Replacing the Battery

The CS40 resets when you remove the battery.

To replace the battery

- 1 Save your files and close any open applications.
- 2 Tap **Start** > **Shutdown** to turn off the CS40.
- 3 Push the battery release tab forward until the battery releases, and lift the battery away from the CS40.

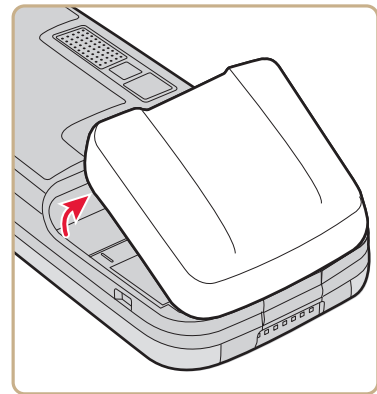
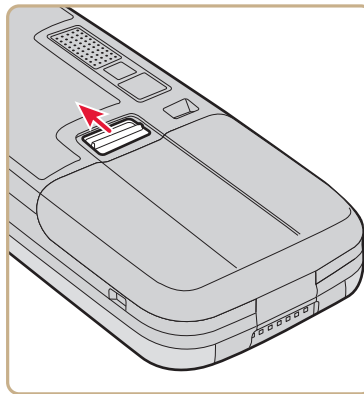





- 4 Insert the bottom of a fully charged battery into the CS40, and press down firmly on the top of the battery. Make sure that the battery release tab is fully engaged.

About Battery Status

Use the battery icon to see the power status of your battery.

Battery Icon Status

Icon	Status
	Battery is fully charged.
	Battery has a medium charge. You should be able to work for several more hours before changing batteries.
	Battery is low. You need to charge or replace the battery soon.
	Battery is critically low. You need to replace the battery now.
	Battery is charging.

Use the battery status LED to see the charging status of your battery.

Battery Status LED States

LED State	Description
Steady green	The CS40 is connected to a charger and the battery is more than 95% charged.
Blinking red	The battery is low. The CS40 goes into Suspend mode. Charge or replace the battery.
Steady red	The CS40 is connected to a charger and the battery is charging.
Steady amber	There is a battery error. The battery may be outside the allowable charging temperature or you may need to replace the battery.
Off	The CS40 is not on external power and the battery is operating normally.

About Battery Life and Conservation

Batteries that are stored outside the CS40 for long periods of time slowly discharge. Intermec recommends storing the battery in a charger to maintain battery performance.

Battery Conservation Tips

When You Want To:	Do This to Save Battery Power:
Use the CS40 and the Low Battery status icon appears or the Battery light comes on.	<ul style="list-style-type: none"> • Connect the CS40 to an external power source. • Or, save your data and tap Start > Shutdown. After the CS40 turns off, remove the battery and insert a fully charged battery.
Stop using the CS40 for 5 minutes or longer.	Make sure the low battery icon is not on the screen and the Battery light is not turned on. Press and hold the Power button for about 2 seconds to suspend the CS40.
Store the CS40 for more than a day.	<p>If you are storing the CS40 for a few days, such as over the weekend, install a charged battery or connect the CS40 to a power source.</p> <p>If you are storing the CS40 for longer, remove and charge the battery, and then store both the battery and CS40 in a cool location. If you store the battery for several months, recharge the battery to keep it at peak performance.</p>
Store the battery outside the CS40.	Store the batteries in a charger.

About the Keypad

The CS40 comes with either a QWERTY or numeric keypad.

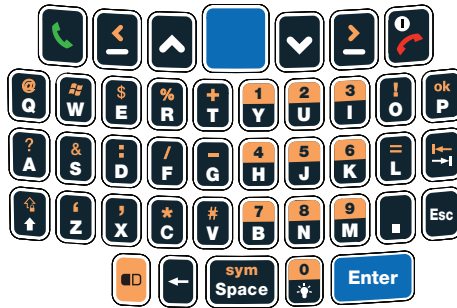

CS40 QWERTY Keypad





CS40 Numeric Keypad

About the Power Button

When you press and hold the **Power** button for about 2 seconds, you put the CS40 into suspend mode. In this lower power mode, the CS40 continues to supply power to all memory, but turns off power to most hardware, such as the display. This power-saving feature is designed to prolong battery life.

Entering Characters on the QWERTY Keypad

You need to use the orange modifier key  and the Shift key  to access all characters and functions.

To type a character

- Press the key for the character.



To type a character or access a function on the overlay



- 1 Press . The key status LED turns orange.
- 2 Press the key for the character or function.

To only type characters or access functions on the overlay



- Press  twice. The key status LED turns orange and stays on.

To type uppercase letters

- 1 Press   to turn on Caps Lock. The key status LED turns green.
- 2 Press the key for the character.



Caps Lock stays on until you press   again.

While Caps Lock is on:

- you can type orange modifier characters by pressing  and the key for that character.
- you can type lowercase letters by pressing  and the key for the character.

For information on how to enter specific characters with keystrokes, see Appendix C, “[Keypads and Keystrokes.](#)”

Entering Characters on the Numeric Keypad

You need to use the orange modifier key  and the green modifier key  to access all characters and functions.

To type a character

- Press the key for the character.





To type a character or access a function in orange on the overlay

- 1 Press . The key status LED turns orange.
- 2 Press the key for the character or function.



The orange modifier key stays on until you press  again.



To type lowercase letters

- 1 Press . The key status LED turns green.
- 2 Press the corresponding number key as many times as necessary depending on the position of the letter you want to type.



For example, to type a lowercase letter z, press     .

To type uppercase letters

- 1 Press   to turn on Caps Lock. The key status LED turns green.
- 2 Press the number key as many times as necessary depending on the position of the letter you want to type.

Caps Lock stays on until you press   again.

While Caps Lock is on:

- you can type orange modifier characters by pressing  and the key for that character.
- you can type lowercase letters by pressing  and the corresponding number key as many times as necessary depending on the position of the letter you want to type.

For information on how to enter specific characters with keystrokes, see Appendix C, “[Keypads and Keystrokes.](#)”

Adjusting the Volume

You can adjust the computer volume for your needs and your environment. The volume includes sounds you hear when you tap the screen or read bar codes with the imager. You can set the volume to off, very low, low, medium, high, very high (default), or vibrate.

To adjust the volume

- 1 Tap the Volume (🔊) icon at the top of the screen, and then tap the volume icon from the menu.

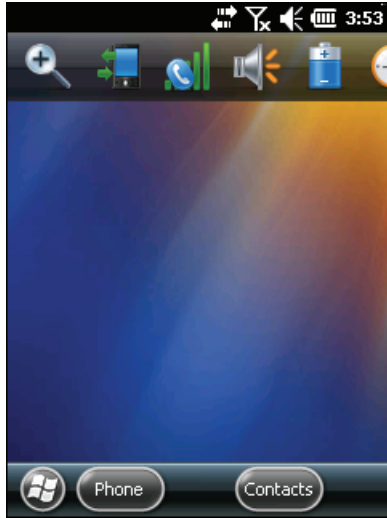

- 2 Use your stylus or the ⬆️ and ⬆️ keys to adjust the volume slider to the volume you want, select **Vibrate**, or select **Off**.

Configuring Backlight Settings

You can turn on the backlight to see the screen better, or you can turn off the backlight to help conserve battery power.

To turn the backlight on and off

- If you have a QWERTY keypad, press ⌘.
- If you have a numeric keypad, press Ⓜ Ⓜ.

By default, the CS40 goes into Screen Off mode when there is no activity. Screen Off mode turns off the backlight and display. Press a key or tap the screen to resume activity.

To configure the backlight

- 1 Tap the Battery (🔋) icon at the top of the screen, and then tap the battery icon from the menu.
- 2 With **Turn off backlight if device is not used for** checked, select the timeout value (30 seconds, or 1 to 5 minutes).

About the Status LEDs

The CS40 has four status LEDs.

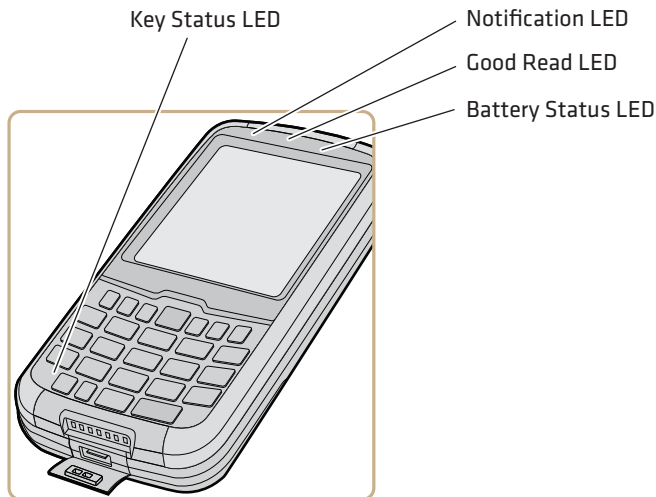

Location of the Status LEDs

Status LED Descriptions

LED	Color	Description
Notification	Amber	The computer is notifying you of a pending alarm or message.
Good Read	Green	The computer has successfully decoded a bar code.
Battery		See “About Battery Status” on page 6.
Key Status	Green	Caps Lock is enabled (QWERTY keypad). Green function keys are enabled (numeric keypad).
	Amber	Orange function keys are enabled.

About the Imager

The CS40 uses an area imager to perform these tasks:

- Read bar codes, including 1D, 2D, and composite symbologies and postal codes.
- Capture signatures. Use the imager to “photograph” signatures on business forms, or to capture onscreen signatures or line drawings.

About Bar Codes

To easily enable or disable bar code symbologies, read one of the bar codes in the table, “**Symbology Bar Codes**” on page 73.

You can use EasySet to create configuration bar codes specific to your system. You can download a free copy of EasySet from the CS40 web page on the Intermec web site at www.intermec.com.

To develop an application you can use to configure the imager, use the Data Collection Resource Kit. The resource kit is part of the Intermec Developer Library (IDL) and can be downloaded from the Intermec web site at www.intermec.com/idl.

Reading Bar Codes

Use the imager to scan 1D and 2D bar code symbologies, composite symbologies, and postal codes. You can position the CN4 in almost any orientation to scan a bar code label.



Note: When the Pictures & Videos application is running, you cannot use the imager.

To read a bar code

- 1 Enable only the bar code symbologies that you need.
- 2 Use Intermec Settings to choose the predefined imager mode that best suits your environment:

Predefined Mode	For Scanning
1D	Only 1D labels.
1D and 2D Standard (Default)	All types of bar code labels.
1D and 2D Bright Environment	In high ambient light, such as outdoors in the sunshine.
1D and 2D Reflective Surface	Glossy labels.
Custom	In conditions that require customized settings. For complete information about these settings, commands, and parameters, see the <i>Intermec Settings Command Reference Manual</i> .

- 3 Point the imager window at the bar code label, and hold the CS40 steady a few inches from the label.
- 4 Press the **Scan** button. The laser pointer and illumination beam and frame appear.

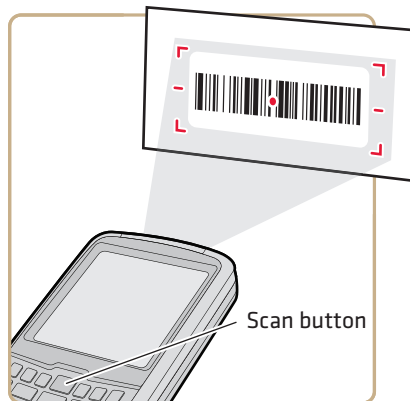

- 5 Use the laser pointer as a guide and aim toward the middle of the bar code. Make sure that the illumination frame covers the bar code you are trying to decode.

When the CS40 successfully reads a bar code label, the Good Read LED turns on briefly.

- 6 Release the **Scan** button.

About Signature Capture

A signature capture is a grayscale image of a signature on paper or other business form. To use signature capture in your applications, use the SignatureCapture components in the Data Collection Resource Kit.

Ink capture is the process of saving an onscreen image, such as a signature or simple line drawing, to a file. To use ink capture in your applications, use the InkCapture components in the Mobile Gadgets Resource Kit.

Both Resource Kits are part of the Intermec Developer Library (IDL) which you can download from the Intermec web site at www.intermec.com/idl.

About the Color Camera

You can use the color camera to:

- take, view, and edit pictures.
- record and launch video clips stored on the CS40 or a microSD card.
- configure camera options.

You can also send pictures and video clips to others or save an image as the background on the Today screen.





Note: While the Pictures & Videos application is running, you cannot use the imager.

Taking a Picture

You can take photos in high, normal, or low quality, with image sizes up to 2048 x 1536 pixels. When you take a picture, the image is saved as a .jpg file and stored in the /My Documents/My Pictures folder.

To take a picture with the camera

- 1 Tap **Start** > **Pictures & Videos**.
- 2 Tap the **Camera** icon, the **Camera** button, or press **Enter**.
- 3 Using the screen as a viewfinder, move the camera until you have the image you want to capture.

Press  to zoom in, or press  to zoom out.



- 4 Tap **Take Pic** or press **Enter** to take and save the picture. If you choose to save your pictures to Main memory, they are saved to permanent storage on the CS40.

Recording Video

You need to switch to video mode to record video. When you record video, the video is saved as an .mp4 file and stored in the /My Documents/My Pictures folder.

To switch to Video mode and record video

- 1 Tap **Start** > **Pictures & Videos**.
- 2 Tap the **Camera** icon, the **Camera** button, or press **Enter**.
- 3 Tap **Menu** > **Video**. The camera icon in the lower right corner turns into a video camera, and the **Record** button replaces the **Take Pic** button.
- 4 Using the screen as a viewfinder, move the camera until you see the scene you want to record.

Press  to zoom in, or press  to zoom out.

- 5 Tap **Record** or press **Enter** to start recording.
- 6 When you are done, tap **Stop** or press **Enter** to stop recording and save the video. If you choose to save your videos to Main memory, they are saved to permanent storage on the CS40.

Saving Pictures and Videos to an SD Card

Pictures and videos are automatically saved to the main memory on your CS40. You can save your pictures and video to an SD card to easily transport them to another device.

To save picture and video files to an SD card

- 1 Install a miniSD card.
- 2 Tap **Start** > **Pictures & Videos**.
- 3 Tap the camera icon.
- 4 Tap **Menu** > **Settings**.
- 5 From the **Save file to** list, select **SD card**, and tap **OK**.

Inserting a microSD Card

You can use a microSD card to increase file storage and install software. The CS40 supports an optional 32 GB maximum capacity microSD™ card.

To install a microSD card

- 1 Tap **Start** > **Shutdown** to turn off the CS40.
- 2 Push the battery release tab forward until the battery releases, and lift the battery away from the CS40.
- 3 Open the card access door.

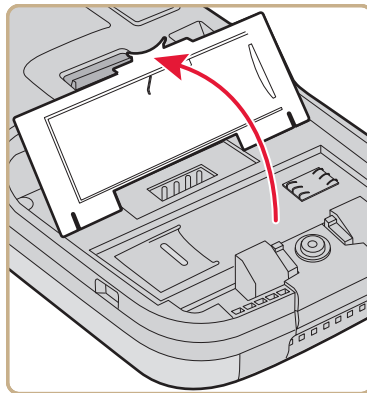

- 4 Slide the microSD card door to the left to unlock it and open the door.

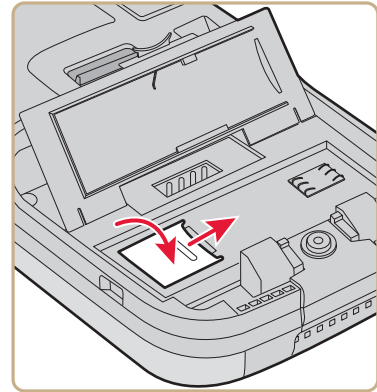
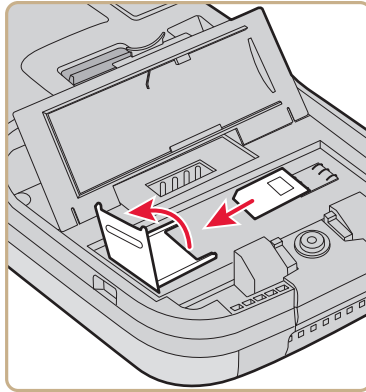

- 5 Slide the microSD card into place.
- 6 Close the microSD card door and slide it to the right to lock it in place.
- 7 Close the card access door.
- 8 Install the battery.
- 9 Press the **Power** button. The CS40 cold boots.

How to Enable the Integrated GPS on the CS40

The CS40 comes equipped with an integrated Global Positioning System (GPS) receiver. It can deliver standards-based National Marine Electronics Association (NMEA) data strings to GPS applications. Intermec recommends that you use the GPS Intermediate Driver (GPSID) instead of directly accessing the GPS hardware. The GPSID is a Microsoft software component that interacts between applications and the GPS hardware.

Using the GPSID allows Intermec support for Extended Ephemeris, which enhances GPS performance by:

- reducing the amount of time it takes your GPS receiver to acquire a fix.
- eliminating the need to obtain precise satellite data information from the GPS satellites.

And, as a Microsoft software component, the GPSID also provides these benefits:

- Allows multiple applications to simultaneously access the GPS data stream.
- Provides access to GPS data without requiring applications to recognize and parse NMEA syntax.

Using the GPSID Installed on the CS40

To use the GPSID installed on your computer, you need to configure the GPSID settings.

To configure your GPSID settings

- 1 Tap **Start > Settings > System > External GPS**. The GPS Settings screen appears with **Programs** selected.

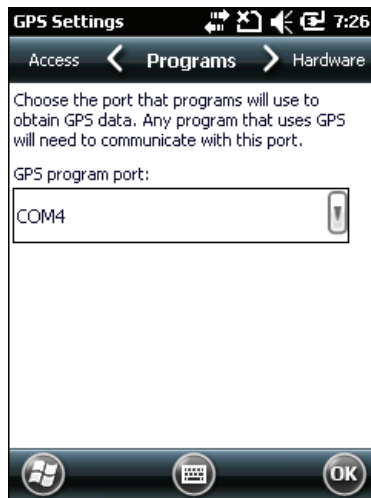

- 2 Select the COM port that you want your programs to use to get GPS data from your CS40.

- 3 Tap **Access** and select the **Manage GPS automatically** check box.

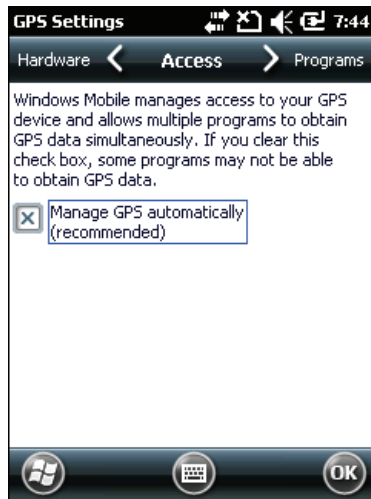

- 4 Tap **ok**.

Improving GPS Performance on the CS40

The integrated mobile computer GPS module has three operating modes:

- Standalone-GPS (default)
- Assisted GPS
- Qualcomm XTRA

In Standalone mode, the CS40 GPS module relies solely on GPS satellites to determine position.

In Assisted GPS mode, the mobile computer can determine position without receiving GPS signals directly from satellites; instead, the mobile computer receives GPS signals and information provided by the cellular network. Even when the mobile computer can receive a satellite signal, Assisted GPS can improve position accuracy and reduce the time to determine initial position (Time-To-First-Fix). Check with your cell phone carrier for availability and pricing for Assisted GPS service.

Qualcomm XTRA Assistance technology provides enhanced operation for Standalone-GPS. This option lets the CS40 automatically download a small assistance data file from the XTRA servers through a brief internet access session.

To improve GPS performance

- 1 Tap **Start > Settings > System > GPS Settings**.
- 2 Select **Improve accuracy** and choose an operating mode.

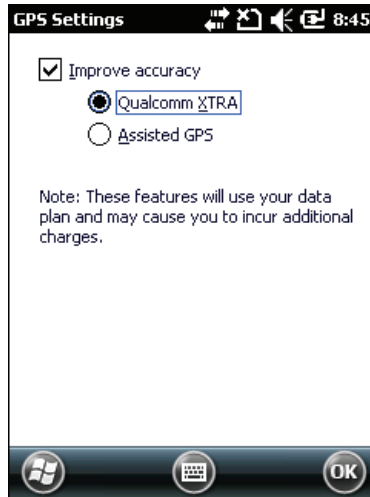

About Additional GPS Options for the Computer

Intermec provides enhanced feature support for the Extended Ephemeris data capability. For more information about programming for Extended Ephemeris GPS, visit the Intermec Developer Library at www.intermec.com/idl.

2

Connecting and Configuring the CS40

Use this chapter to understand how to configure the mobile computer to communicate in your network. This chapter contains these topics:

- **How to Configure the CS40**
- **About SmartSystems Foundation**
- **How to Connect the CS40 to a PC**
- **How to Connect the CS40 to Your Network**
- **About the Phone**
- **Connecting to an ISP**
- **Connecting to a Network With a VPN Server**

How to Configure the CS40

You can configure many parameters of the CS40, such as the bar code symbologies it decodes or the network settings. The values you set for these configuration parameters determine how the CS40 operates.

There are several ways to configure the mobile computer:

- You can use the Scan-to-Connect utility, which is part of SmartSystems Foundation, to quickly provide the computer with the minimal information necessary to connect to a secure network. For more information, see the next section “**About SmartSystems Foundation.**”
- You can use a third party device management product that supports the computer, such as the Microsoft System Center Mobile Device Manager. For more information, visit the Microsoft web site at <http://msdn.microsoft.com/en-us/default.aspx>.
- You can use Imager Configuration Bar codes to enable or disable symbologies, reset to factory defaults, and set predefined imager modes. For more information, see “**Imager Configuration Bar Codes**” on page 72.

About SmartSystems Foundation

SmartSystems™ Foundation is an Intermec software platform that lets you manage all of your SmartSystems-enabled devices simultaneously from a central server. The SmartSystems Console displays all SmartSystems-enabled computers and peripherals in your network.

Through the Console, you can:

- drag-and-drop configuration bundles, OS updates, and firmware upgrades to multiple computers.
- create a “golden” device configuration to use when updating other computers.
- remotely change settings on SmartSystems-enabled computers and peripherals.

With an AutoDeploy license, SmartSystems can automatically push software, configuration settings, and other files to connected mobile computers. AutoDeploy can report on asset locations and battery status, making it easier to manage your mobile devices. The license also enables Scan-to-Connect, which makes connecting additional mobile computers to your secure wireless network as easy as reading bar codes.

You can download SmartSystems Foundation at no charge from the Intermec web site. For more information on SmartSystems, go to www.intermec.com/SmartSystems. To purchase an AutoDeploy license, contact your local Intermec sales representative.

How to Connect the CS40 to a PC

You can use Microsoft ActiveSync (Windows XP or earlier) or Windows Mobile Device Center (Windows Vista or Windows 7) to establish a connection between your CS40 and PC. After you connect to your PC, you can transfer files, synchronize files, remotely debug, and perform other device management activities. ActiveSync and Windows Mobile Device Center are free applications available from the Microsoft web site at www.windowsmobile.com/getstarted.

To connect your CS40 and PC, you need to physically connect your CS40 to your PC using the power and data y-cable accessory.

How to Connect the CS40 to Your Network

The CS40 is a versatile mobile computer that you can easily add to your wireless or wired data collection network. You can connect your computer using:

- 802.11 radio communications.
- Bluetooth communications.
- Ethernet communications
- USB communications.

Connecting the CS40 Using 802.11 Radio Communications





Make sure all components with antennas are at least 30 cm (1 ft) apart when power is applied. Failure to comply could result in equipment damage.

Your CS40 has an 802.11 radio to transfer data using wireless communications. This section assumes that your wireless network is set up, including your access points.

To configure 802.11 radio parameters

- 1** Tap **Start** > **Settings** > **Connections**.
- 2** Tap **Wi-Fi**. The Wi-Fi page appears.
- 3** If the Network you want to connect to is available in the wireless networks list, tap the network name and continue with Step 4.
If the Network you want to connect to is not in the wireless networks list:
 - a** Tap **Add New**. The Configure Wireless Network page appears.
 - b** In the **Network name** field, enter the name of your network and tap **Next**. The Configure Network Authentication page appears.
- 4** From the **Authentication** list, choose either **Open**, **Shared**, **WPA**, **WPA-PSK**, **WPA2**, or **WPA2-PSK**.
 - If you choose **Open** or **Shared**, **Data Encryption** is automatically set to WEP and the key is automatically provided.
 - If you choose **WPA**, Data Encryption is automatically set to **TKIP**.
 - If you choose **WPA2**, Data Encryption should be set to **AES**.
 - If you choose **WPA-PSK**, **Data Encryption** is automatically set to TKIP and you need to enter a **Network key**.
 - If you choose **WPA2-PSK**, **Data Encryption** should be set to AES and you need to enter a **Network key**.

- 5** Tap **Next**.
- 6** For **EAP type**, select either **PEAP** or **Smart Card or Certificate** from the list and tap **Finish**. You return to the Configure Wireless Networks page.
- 7** Use the  and  arrow keys to select your network from the list and tap **Connect**.
- 8** When prompted, enter this network information:
 - User name
 - Password
- 9** Tap **OK**. Your CS40 connects to the network.
- 10** Make sure that your CS40 is talking to the network and that the network can see your CS40. If you are connected to the wireless network, a connected icon () appears on the navigation bar and the name of your network appears next to Wi-Fi in the Wireless Manager.

Connecting the CS40 Using Bluetooth Communications

Your CS40 is Bluetooth™-enabled, which lets you connect to other Bluetooth devices, such as printers.

You need to turn on the Bluetooth radio before you can discover and connect to other Bluetooth devices. By default, the radio is turned off.

To turn on the Bluetooth radio

- 1 Tap **Start > Settings > Bluetooth > Mode**.
- 2 Tap the **Turn on Bluetooth** check box.

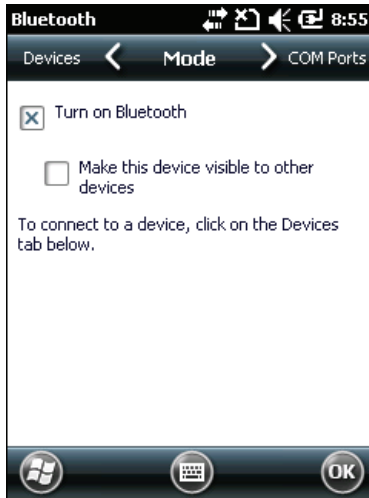

- 3 (Optional) If you want your CS40 to be visible to other Bluetooth devices, tap **Make this device visible to other devices**.
- 4 Tap **ok**.

The Bluetooth radio maintains its current state through a warm or cold boot and maintains virtual COM ports. If you clean boot your v, you need to recreate pairings to devices.

Connecting the CS40 to a Wireless Printer

To configure your CS40 for Bluetooth wireless printing, you need to:

- make sure Bluetooth power is on. For help, see the procedure in **“Connecting the CS40 Using Bluetooth Communications” on page 27**.
- create an application that opens the wireless printing COM port on your CS40. For help, see the Bluetooth Resource Kit, which is part of the Intermec Developer Library (IDL), available from the Intermec web site at www.intermec.com/idl.
- select the current wireless printer on your CS40. For help, see the next procedure.

To select the current wireless printer

- 1 Select **Start > Settings > System > Wireless Printing**.

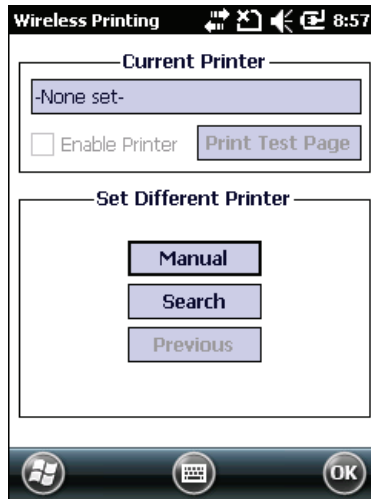

- 2 Tap **Search** to find a printer, or tap **Manual** to enter a device address. Follow the onscreen instructions to select the current wireless printer.
- 3 (Optional) Tap **Print Test Page**. The printer prints out the test page.



Note: You can also print wirelessly from inside your applications using Microsoft APIs with Bluetooth extensions for Winsock and Bluetooth virtual COM ports. For help, see the Bluetooth Resource Kit documentation.

Connecting the CS40 Using Ethernet Communications

You connect your CS40 to your Ethernet network using these accessories:

- USB Ethernet adapter cable
- Power and data y-cable

To use your computer in an Ethernet network

- 1** Connect your CS40 to the power and data y-cable.
- 2** Connect the power and data y-cable to the USB connector of the USB Ethernet adapter cable. Ethernet communications is automatically enabled on your CS40.
- 3** Make sure that your CS40 is communicating with the network. You should see the network connection icon () in the navigation bar.

Connecting the CS40 Using USB Communications

You can use the power and data y-cable accessory to transmit data to and receive data from a desktop PC through USB communications. The USB port supports both USB client and USB host. The port automatically senses the cable you are using and determines which drivers to use. For more information about this accessory and how to order it, see **“CS40 Accessories” on page 3**.

About the Phone

Your CS40 supports UMTS mobile wireless phone technology. With the radio module installed in your CS40, you can send and receive telephone calls as well as transmit data through wide-area (WAN) cellular networks.

The CS40 has a phone speaker, microphone, and speakerphone. It also supports the use of a Bluetooth headset or hands-free kit. The factory default setting for the phone is disabled.

After you turn on the phone and activate service with your wireless carrier, you can customize the features of the phone and network settings. For help, see the online help on your mobile computer.

Turning On the Phone Using the Wireless Manager

You can use the Wireless Manager to enable and disable Bluetooth, Wi-Fi, and the phone on your CS40.

To turn on the phone using the wireless manager

- 1 Tap **Start** > **Settings** > **Connections** > **Wireless Manager** > **Enable** > **Phone**. The phone turns on.
- 2 Tap the **Personal** tab, and then tap **Phone** to configure the phone. For help, see the next procedure, “[Activating the UMTS Radio](#).”
- 3 Tap **Done** to close the Wireless Manager.

Activating the UMTS Radio

You use a SIM card to activate the UMTS/HSPA phone on your CS40. You can purchase the SIM card from your network provider.

To install the SIM card and activate the UMTS radio

- 1 Tap **Start** > **Shutdown** to turn off the CS40.
- 2 Push the battery release tab forward until the battery releases, and lift the battery away from the computer.
- 3 Open the card access door.

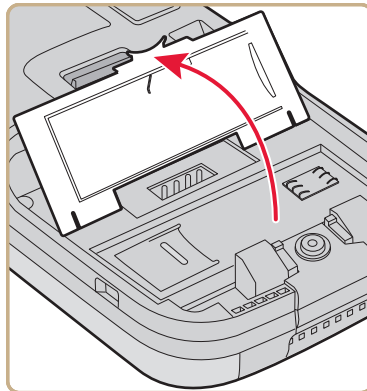

- 4 Slide the SIM card into the slot in the card access door.

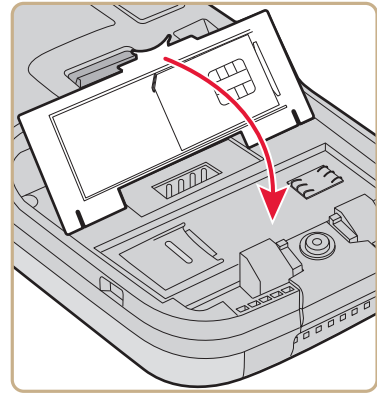
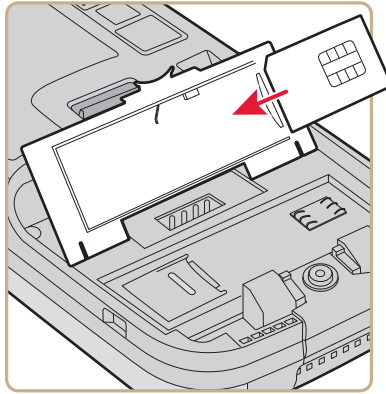

- 5 Close the card access door.
- 6 Install the battery.
- 7 Press the **Power** button. The CS40 cold boots.

Making a Phone Call

After you activate your phone, you are ready to start making phone calls. The icon on the navigation bar changes to indicate that the radio is now active.

To make a phone call

- 1 Tap **Start** > **Phone**.
- 2 Tap the keys to enter the telephone number you want to call.
- 3 Tap the **Talk** button.

Connecting to an ISP

You can connect to your Internet Service Provider (ISP), and use the connection to send and receive e-mail messages and view web pages. Get an ISP dial-up access telephone number, a user name, and a password from your ISP.

Tap the **Help** icon at any time to view additional information for the wizard or the settings.

To connect to an Internet service provider

- 1 Tap **Start** > **Settings** > **Connections**.
- 2 Under My ISP, tap **Add a new modem connection**.

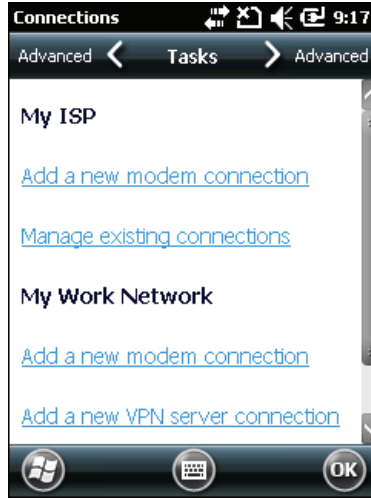

- 3 Enter a name for the connection, such as “ISP Connection.”
- 4 If you are using an external modem connected to your mobile computer with a cable, select **Hayes Compatible on COM1** from the Select a modem drop-down list.
- 5 Tap **Next**.
- 6 Enter the access phone number and tap **Next**.
- 7 Enter the **User name**, **Password**, and **Domain** (if provided by an ISP or your network administrator).
- 8 Tap **Finish**.
- 9 From the Connections screen, tap the **Advanced** tab, and then tap **Dialing Rules**.
- 10 Select **Use dialing rules**, tap **ok** at the dialog box, and then tap **Edit**.
- 11 Specify your current phone type and then tap **ok** until you exit and return to the Settings page.

After your mobile computer is connected, you can:

- send and receive message using Messaging (Outlook E-mail).
- visit web pages using Internet Explorer Mobile.

Connecting to a Network With a VPN Server

A VPN connection helps you to securely connect to servers, such as a corporate network, through the Internet. Before you can make a VPN connection, you need this information from your network administrator:

- User name
- Password
- Domain name
- TCP/IP settings
- Host name or IP address of the VPN server

To create a VPN server connection to work

- 1** Tap **Start > Settings > Connections**.
- 2** Under My Work Network, tap **Add a new VPN server connection**.

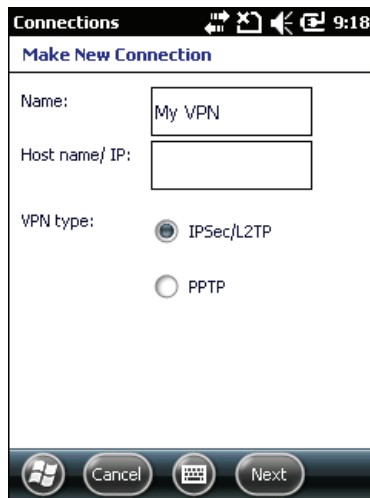

- 3** Step through the screens to set up your VPN connection.

3

Developing and Installing Applications

Use this chapter to understand the guidelines for developing applications for use on your CS40. This chapter contains these sections:

- **How to Develop Applications for the CS40**
- **How to Install Applications on the CS40**
- **How to Update the System Software**

How to Develop Applications for the CS40

Use the Intermec Resource Kits to develop new applications to run on your CS40. The Resource Kits are a library of components grouped by functionality that you can use to create applications for your CS40. The Resource Kits are part of the Intermec Developer Library (IDL), and you can download them from the Intermec web site at www.intermec.com/idl.

To use the Resource Kits, you need Microsoft Windows Mobile SDK and Microsoft Visual Studio 2005. For more information on IDL, see the *Intermec Developer Library Resource Kit Developer's Guide*.

How to Package Your Application

For very simple applications, the executable file may be the only file you need to deploy. More typically, you will have a set of files to install.

Intermec recommends using .cab files to install your applications. The CN4 uses standard Windows Mobile .cab files and will install third-party .cab files.

How to Choose a Target Location

You can have your .cab file place your application in any of these memory locations on the CN4:

- The ObjectStore.
- The optional miniSD card. Depending on available disk space, you may want to consider installing your application files on the miniSD card. Using a card creates the Storage Card folder on the CN4.
- The non-volatile Flash File Store. Applications and data in the Flash File Store will persist through a clean boot.

Note: The Flash File Store may be erased if you reflash the image.



Files copied to any of these locations are safe when you cold boot the computer as long as the AutoRun system is installed in the appropriate location. When AutoRun is installed on the computer, all .cab files in the CabFiles folder are automatically extracted after a cold boot. For more information about AutoRun, see the *Intermec Developer Library Resource Kit Developer's Guide*.

How to Install Applications on the CS40

There are several ways you can install files and applications on your CS40:

- SmartSystems console
- ActiveSync or Windows Mobile Device Center
- Scan to Load hands-free software loading function of SmartSystems Foundation
- microSD card

For more information about installing applications, see the *Intermec Developer Library Resource Kit Developer's Guide*.

Installing Applications Using SmartSystems Foundation Console

You can use the SmartSystems Foundation console to drag-and-drop Intermec applications onto your CS40.

To use SmartSystems Scan-to-Connect to connect your CS40 to your network and install software, see the SmartSystems Foundation online Help.

To use SmartSystems console to install an application

- 1** Download your application file from the Intermec web site and unzip it on your desktop PC.
- 2** Double-click the application file to install it. The application file should appear in the Software Vault.
- 3** From the SmartSystems console in the Software Vault, drag-and-drop the application onto each CS40 in your network, or drop the application on a group of CS40s contained in a folder.

For more information, go to the Intermec web site at www.intermec.com/SmartSystems.

Installing Applications Using Microsoft ActiveSync or Windows Mobile Device Center

If you only have a few CS40s to update with applications, you can copy files using Microsoft ActiveSync or Windows Mobile Device Center.

To install an application using Microsoft ActiveSync or Windows Mobile Device Center

- 1** On your PC, copy the .cab file you want to download to your CS40.
- 2** Create an ActiveSync or Windows Mobile Device Center connection between your PC and your CS40.
- 3** Copy the .cab files from your PC to your CS40.
- 4** Warm boot or cold boot your CS40. For help, see “[Resetting the Computer](#)” on page 50.
- 5** After the boot process is finished, browse to the .cab files and tap the files to install them.

How to Install Applications Using a Scan-to-Connect Bar Code

You can use the Scan-to-Connect function in SmartSystems Foundation to create a bar code that loads software. The bar code contains the address of the server where the software to download is located. Once you scan the bar code, it finds the server, downloads the file, and installs it on your CS40. For more information on installing applications using a Scan-to-Connect bar code, see the SmartSystems Foundation Help.

Installing Applications Using a microSD Card

If your application requires more disk space than your CS40 can comfortably handle, you can use a microSD card to install applications.

To install applications using the microSD card

- 1 Tap **Start** > **Shutdown** to turn off your CS40.
- 2 Remove the microSD card. For help, see **“Inserting a microSD Card” on page 17.**
- 3 Insert the microSD card into a microSD adapter card, and then place it in the storage card reader connected to your PC.
- 4 Copy your application file to the microSD card.
- 5 Remove the microSD card from the adapter card and insert it into your CS40.
- 6 On your CS40, navigate to the storage card folder and run your application.

How to Update the System Software

Your CS40 uses Image Update to update the operating system (OS) and system software. Image Update uses packages to allow for smaller and faster updates because the contents are stored in ROM. Packages persist through a cold or clean boot and cannot be removed by the end user. The Image Update process also provides strengthened security because all packages are signed.

Image Update packages (.pkg or .pks files) may contain elements such as DLLs, executable (.exe) files, and .cab files.

You can use either of these methods to update your CS40:

- You can update multiple computers at the same time using the SmartSystems Console. For help, see the next section, **“Updating Multiple CS40s Using SmartSystems Console.”**
- You can update individual computers by transferring the packages to your mobile computer and then installing them from the mobile computer.

If you are using SmartSystems to update your CS40 you can choose to send the updates silently. For more information, see **“How to Send Silent Update Packages to the Computer” on page 41.**

Updating Multiple CS40s Using SmartSystems Console

You can use the SmartSystems console to update the operating system or system software on your CS40. The console is part of SmartSystems Foundation and is available from the Intermec web site through the Intermec Developer Library (IDL). Before you can upgrade your CS40, you need:

- SmartSystems Foundation. To download SmartSystems Foundation, go to www.intermec.com/idl and open the Device Management page.
- the SmartSystems bundles you want to install. The SmartSystems bundle contains the Image Update package file. These SmartSystems bundles are available from the Intermec web site at www.intermec.com. Go to **Support > Downloads**.

To update your CS40 using SmartSystems Foundation

- 1 Open the SmartSystems console.
- 2 Make sure the SmartSystems console and your CS40 are on the same subnet and connected wirelessly or through Ethernet.
- 3 Make sure that power management is disabled on your CS40.
- 4 Download the SmartSystems bundle to your PC.
- 5 Double-click the SmartSystems bundle on your PC to extract the update files to the software vault.
- 6 From the SmartSystems console, locate the bundle(s) to install.
- 7 Drag the application to each mobile computer you want to update or to a group of mobile computers in a folder. The SmartSystems console installs the update on your computers.
- 8 After the download is complete, your mobile computer begins the update process and automatically performs a cold boot.

The mobile computer then boots into a special Update Loader mode where the computer has no connections and is completely unusable. This process can take anywhere from 30 seconds to 15 minutes depending on the update.

Note: The SmartSystems console indicates that your mobile computer is offline, by displaying a red stop sign symbol, until the mobile computer reboots and reconnects to the system.



- 9 After the update is complete, your mobile computer cold boots again. When a confirmation dialog box appears requesting user input, dismiss it.

How to Send Silent Update Packages to the Computer

If you want to automatically download and send update packages to your CS40, you can purchase a SmartSystems AutoDeploy License. The silent updates do not require any user intervention and begin when you choose to have the update process start. SmartSystems Foundation users are notified when update packages are released so that they can download them and update their Intermec computers. For more information, see the SmartSystems Foundation Help.

Updating Individual CS40s

You can download update packages from your PC to your CS40 using Microsoft ActiveSync (Windows XP or earlier), Windows Mobile Device Center (Windows Vista or Windows 7), or any other file transfer method you choose.

To update an individual CS40

- 1 Download the Image Update packages you want to install from the Intermec web site at www.intermec.com. Go to **Support > Downloads**.
- 2 Transfer the Image Update packages from your PC to your CS40.
- 3 On your CS40, tap **Start > File Explorer** and navigate to the location of the Image Update package.
- 4 Double-tap the package to install it. Your CS40 validates the update package and prompts you to continue with installation.
- 5 Tap **Install**.
Your CS40 boots and enters a special Update Loader mode where the computer has no connections and is completely unusable. This process can take anywhere from 30 seconds to 15 minutes depending on the update.
- 6 When the installation is complete, an Update Result page appears. Tap **Done**.

4

Troubleshooting and Maintaining the Computer

If you encounter any problems while using the mobile computer, look in this chapter to find a possible solution. You will also find information on routine maintenance. This chapter contains these sections:

- **Calling Product Support**
- **Troubleshooting the Computer**
- **Resetting the Computer**
- **Cleaning the Computer**

Calling Product Support

If you cannot find the answer to your problem in the “**Troubleshooting the Computer**” section, you can visit the Intermec technical knowledge base (Knowledge Central) at intermec.custhelp.com to review technical information or to request technical support. If you still need help after visiting Knowledge Central, you may need to call Product Support.

To talk to an Intermec Product Support representative, call **1-800-755-5505**.

Before you call Intermec Product Support, make sure you have the following information ready:

- Configuration number
- Serial number
- Firmware and software version numbers
- Know the language your custom application was written in and the tools you used to create it

Consult your application developer for information on your custom application.

To find your configuration number and serial number

- Look at the CN (configuration number) and SN (serial number) fields on the label inside the battery compartment.

To find software and firmware version numbers

- 1 Go to **Start > Settings > About**.
- 2 Tap the **Packages** tab to find software version numbers.
- 3 Tap the **Build** tab to find the firmware version.

Troubleshooting the Computer

Use this section to troubleshoot some common problems you may experience with your CS40.



Note: If you send your CS40 in for service, it is your responsibility to save the computer data and configuration. Intermec is responsible only for ensuring that the hardware matches the original configuration when repairing or replacing the computer.

Problems While Configuring the Mobile Computer

Problem	Possible Solution
You cannot type a character on the keypad or you can only type uppercase or lowercase letters.	You may have locked a modifier key on the keypad. Press the necessary key sequence to unlock the key. For help, see “About the Keypad” on page 8 .
You press Ⓞ and nothing happens.	<ul style="list-style-type: none"> • Make sure the backlight is on. • The battery may be discharged. Replace the battery with a spare charged battery, or charge the battery. • Reset the mobile computer. For help, see “Resetting the Computer” on page 50.
You insert a microSD card and cannot find the microSD card folder on the CS40.	<ul style="list-style-type: none"> • The microSD card may not be installed correctly. Insert the microSD card as described in “Inserting a microSD Card” on page 17. • The microSD card may be damaged. Try another microSD card.
The Battery status LED is on.	<ul style="list-style-type: none"> • If the battery status LED is a steady green, the battery is more than 95% charged and computer is on a charger. • If the battery status LED is blinking red, then the battery is low. Replace or charge the battery. • If the battery status LED is a steady red, the main battery is on charge.

Problems While Configuring the Mobile Computer

Problem	Possible Solution
The computer appears to be locked up and you cannot enter data.	<ul style="list-style-type: none">• Press and hold the power key to turn off the mobile computer, and then press the power key again to turn it on.• Cold boot the mobile computer. For help, see “Cold Booting the Computer” on page 50.• Try reloading the firmware. For help, see “How to Update the System Software” on page 39.• If the mobile computer does not boot or reset, contact your Intermec representative for help.
You tap the screen and nothing happens.	<ul style="list-style-type: none">• Make sure the mobile computer is not locked.• Align your touch screen.

Problems With Wireless Connectivity

Problem	Possible Solution
The mobile computer is connected to the network, and you move to a new site to collect data. Now, your mobile computer is not connected to the network.	Move closer to an access point or to a different location to reestablish communications until you reconnect with the network. Any data collected while the mobile computer is out of range is transmitted over the network once the network reconnects.
The mobile computer appears to be connected to the network, but the host computer is not receiving any information from the mobile computer.	There may be a problem with the connection between the access point and the host computer. Check with network administrator or use your access point user’s manual.

Problems While Configuring 802.1x Security

Problem	Possible Solution
The mobile computer indicates that it is authenticated, but it does not communicate with the host.	Make sure the mobile computer IP address, host IP address, subnet mask, default router are configured for the network.
The mobile computer does not appear to be authenticating and a network connection icon does not appear on the toolbar.	<ul style="list-style-type: none">• The mobile computer may not be communicating with the access point. Make sure the mobile computer network name matches the access point network name (SSID).• The 802.1x security network may not be active. Make sure the server software is properly loaded and configured on the server PC. See server software documentation for help.
A network connection icon appears in the toolbar, but then disappears.	<ul style="list-style-type: none">• The mobile computer may not be communicating with the intended access point. Make sure the mobile computer network name matches the access point network name.• The access point may not be communicating with the server. Ensure the access point is turned on, properly configured, and has 802.1x security enabled.
You are setting up multiple access points in a network, with different SSIDs, and the connection fails.	When you change the SSID, the WEP key values are not saved. Configure the WEP key values and save your changes.

Problems While Configuring 802.1x Security (continued)

Problem	Possible Solution
The mobile computer indicates it is not authenticated.	Make sure that: <ul style="list-style-type: none">• the User Name and Password parameters on the mobile computer match the user name and password on the authentication server. You may need to configure the password on both the mobile computer and the authentication server.• on your authentication server, the user and group are allowed and the group policy is allowed to log into the server. For help, see the documentation that shipped with your authentication server software.• the IP address and secret key for the access point match the IP address and secret key on the authentication server. You may need to configure the IP address and secret key on both your access point and authentication server.• the authentication server software is running on the server PC.
You clean boot the mobile computer and this message appears, “The server certificate has expired or your system date is incorrect.”	When you clean boot the mobile computer, the date and time are not saved. Configure the date and time and save your changes.

Problems While Scanning Bar Codes

Problem	Possible Solution
You press the Scan button, but you cannot see a red beam of light.	<ul style="list-style-type: none">• You may be too far away from the bar code label. Try moving closer to the bar code label and scan it again.• You may be scanning the bar code label “straight on.” Change the scanning angle and try again.• Move within two feet of a wall to test the effective scan of the imager. For help scanning bar codes, see “Reading Bar Codes” on page 13.

Problems While Scanning Bar Codes (continued)

Problem	Possible Solution
When you release Scan button, the Good Read LED does not turn off.	<p>If the mobile computer is configured to use continuous/edge triggering, the Good Read LED stays on.</p> <p>If the mobile computer is configured to use level triggering, there may be a problem. Press the Scan button again without scanning a bar code label. If the LED is still on, contact your local Intermec representative.</p>
The imager does not read the bar code label.	<ul style="list-style-type: none"> • Aim the scanning beam so that it crosses the entire bar code label in one pass. Try changing the scan angle. • Check the quality of the bar code label, Scan a bar code label that you know scans well. Compare the two bar code labels to see if the bar code quality is too low. You may need to replace the label that you cannot scan. • Make sure the bar code symbology is enabled. For help, see the Data Collection Resource Kit which is part of IDL. You can download the resource kit from www.intermec.com/idl. • Make sure the application is accepting input by scanning a bar code. You may need to type this information instead.
The imager does not read the bar code labels quickly, or the scanning beam seems to be faint or obscured.	The imager window may be dirty. Clean the window with a solution of ammonia and water. Wipe dry. Do not allow abrasive material to touch the window.
The scanned bar code data that appears in your application does not match the data encoded in the bar code label.	The mobile computer may have decoded the bar code label in a different bar code symbology. Try scanning the bar code label again. Make sure you scan the entire label.

Resetting the Computer

You rarely need to reset the mobile computer. If the CS40 does not resume after pressing the **Power** button, or if the CS40 or an application locks up, you may need to reset the CS40. The CS40 uses the configuration currently saved in flash memory during the boot process. There are three ways to reset the computer:

- Warm booting
- Cold booting
- Clean booting

Warm Booting the Computer

You may need to perform a warm boot to correct conditions when an application stops responding to the system.

To warm boot the computer

- 1 Tap **Start** > **Shutdown**. The CS40 systematically shuts down.
- 2 Press the **Power** button to turn on the CS40. The CS40 goes through the initialization process and restarts.

Cold Booting the Computer

In some cases when the computer completely stops responding, it may be necessary to perform a cold boot. Because cold booting may result in data loss, only use this method if all other recovery methods have failed.



Note: Cold booting the computer does not guarantee that cached disk data will be saved, so transactional data may be lost during the reset. All other data is preserved.

To cold boot your computer

- 1 Remove the battery pack from the computer and wait 30 seconds.
- 2 Install the battery pack and press .

Clean Booting the Computer

If the computer does not warm boot or cold boot, you may need to perform a clean boot. When you clean boot the computer, the computer only loads files and applications that are absolutely required by the operating system. A clean boot returns the computer to an “out of the box” or factory default state, so that you can run diagnostic tests to troubleshoot the normal boot process.



Caution

The clean boot process erases the mobile computer memory, including all applications and data files in the object store. To preserve applications through a clean boot, store them in the Flash File Store. For more information, see “How to Install Applications on the CS40” on page 37.

To clean boot the computer

- 1 Remove the battery pack.
- 2 Install the battery pack and press **(C)**.
- 3 When the computer starts the boot process, simultaneously press **(A)** and **(Z)** until the IPL Boot Configuration Menu appears on the screen.

```
IPL Boot Configuration Menu
-----
(1) Force Image Update: No
(2) Force Clean Boot   : No
(3) Passive KILL      : No
(0) Continue with Boot...
```

- 4 Press **(2)** to select **Force Clean Boot** and then press **(0)** to select **Continue with Boot**.

The computer executes the clean boot. This process takes a few minutes.

- 5 When prompted, tap the screen to set up the computer.
- 6 Follow the instructions to calibrate the screen.

Cleaning the Computer

To keep the computer in good working order, you may need to perform these minor maintenance tasks:

- Clean the imager window.
- Clean the computer screen.

Clean the imager window and computer screen as often as needed for the environment in which you are using the computer. To clean the computer, use a solution of one part ammonia and 3 parts water.



There are no user-serviceable parts inside the computer. Opening the unit will void the warranty and may cause damage to the internal components.

To clean the imager window and computer screen

- 1 Press  to turn off the computer.
- 2 Dip a clean towel or rag in the ammonia solution and wring out the excess. Wipe off the imager window and screen. Do not allow any abrasive material to touch these surfaces.
- 3 Wipe dry.

A

Specifications

Physical and Environmental Specifications

Physical Dimensions

Length:	13.1 cm (5.2 in)
Width (at widest part):	6.2 cm (2.4 in)
Height (at tallest part):	2.4 cm (0.9 in)
Weight (with battery):	200 g (7.1 oz)

Power and Electrical Specifications

Operating:	Rechargeable lithium-ion battery
Battery capacity:	1480 mAh (7.4 Wh)
Electrical rating:	5 V, 1.5 A

Temperature and Humidity Specifications

Operating temperature:	-10°C to 50°C (14°F to 122°F)
Storage temperature:	-20°C to 70°C (-4°F to 158°F)
Charging temperature:	0°C to 45°C (32°F to 113°F)
Relative humidity (operating):	5 to 95% non-condensing
Environmental rating:	IP54

Screen Specifications

- 240 RGB x 320 pixels
- 7.1 cm (2.8 in) diagonal square active area
- LED backlight with 5 levels of brightness, including Off
- LCD capable of both portrait and landscape operation

Keypad Options

- Numeric keypad
- Alphanumeric keypad (QWERTY)

Bar Code Symbolologies

The EA11 imager supports these bar code symbolologies:

- AustraliaPost
- Aztec
- BPO (British Post 4-state)
- ChinaPost
- CanadaPost
- Codabar
- Codablock A
- Codablock F
- Code 11
- Code 39
- Code 93
- Code 128/GS1-128
- DataMatrix
- DutchPost
- EAN/UPC
- GS1 Composite
- GS1 DataBar Expanded
- GS1 DataBar Limited
- GS1 DataBar Omnidirectional
- Infomail
- Interleaved 2 of 5
- JapanPost
- KoreanPost
- Matrix 2 of 5
- Maxicode
- Micro PDF417
- MSI
- PDF417
- Planet
- Plessey
- Postnet
- QR Code
- Standard 2 of 5
- SwedenPost
- Telepen
- TLC 39

CS40 Micro-AB USB Connector Specifications

The CS40 has a standard Micro-AB USB connector:

- 1A maximum charge when using the universal cell phone charger accessory
- maximum VBUS output power of 5 V @ 100 mA

CS40 Docking Connector Specifications

The CS40 has an array of seven pin surface contacts that provide USB “On the Go” (OTG) connectivity and charge power while docked.

CS40 Docking Connector Specifications

Pin Number	Signal Name	Description
1	VEXT	Computer power
2	ID	Identification pin
3	VBUS	VBUS (5 V @ 100 mA max)
4	D-	USB data signal
5	D+	USB data signal
6	GND	Ground (power return)
7	GND	Ground (power return)

EA11 Imager Reading Distances

Typical reading distances are done in an office environment using office lights (4 lux). Minimum distances are measured in the dark (0 lux). Both reading distances are provided in respective scan engine integration guides. Contact your local Intermec representative for more information.

Below are the typical and minimum standard reading distances for the CS40 built with an EA11 imager. When correctly mounted, an exit window reduces reading distances by about 4% for all scan engines.



Note: Minimum distances depend on the length of the bar code.

EA11 Standard Typical Reading Distances

Symbology	Density	Minimum Distance	Maximum Distance
Code 39	0.125 mm (5 mil)	7.2 cm (2.8 in)	13.1 cm (5.1 in)
	0.20 mm (8 mil)	3.8 cm (1.5 in)	22.5 cm (8.8 in)
	0.25 mm (10 mil)	3.4 cm (1.3 in)	27 cm (10.5 in)
	0.50 mm (20 mil)	5 cm (2 in)	44 cm (17.2 in)
	1 mm (40 mil)	8 cm (3.1 in)	83 cm (32.4 in)
UPC/EAN	0.33 mm (13 mils)	5 cm (2 in)	32 cm (12.5 in)
Data Matrix	0.191 mm (7.5 mils)	6.3 cm (2.5 in)	17.3 cm (6.7 in)
	0.254 mm (10 mils)	4.8 cm (1.9 in)	22 cm (8.6 in)
	0.381 mm (15 mils)	*	29 cm (11.3 in)
PDF417	0.168 mm (6.6 mils)	6.25 cm (2.46 in)	15.4 cm (6 in)
	0.254 mm (10 mils)	4.5 cm (1.8 in)	23 cm (9 in)
	0.381 mm (15 mils)	4 cm (1.6 in)	37 cm (14.4 in)

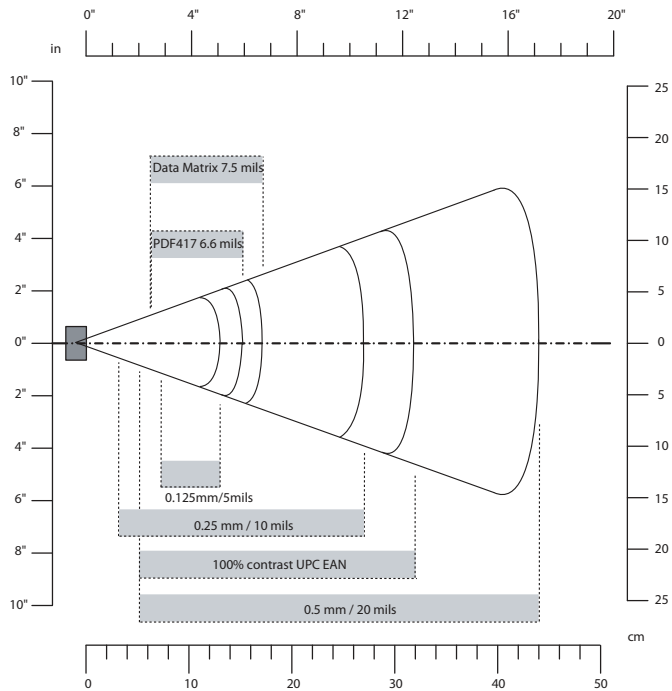

EA11 Standard Typical Reading Distances

EA11 Standard Minimum Reading Distances

Symbology	Density	Minimum Distance	Maximum Distance
Code 39	0.125 mm (5 mil)	7.26 cm (2.86 in)	12.09 cm (4.76 in)
	0.20 mm (8 mil)	3.96 cm (1.56 in)	20.98 cm (8.26 in)
	0.25 mm (10 mil)	3.45 cm (1.36 in)	25.04 cm (9.86 in)
	0.50 mm (20 mil)	4.98 cm (1.96 in)	40.28 cm (15.86 in)
UPC/EAN	0.33 mm (13 mils)	4.98 cm (1.96 in)	29.62 cm (11.66 in)
Data Matrix	0.191 mm (7.5 mils)	3.71 cm (2.46 in)	16.41 cm (6.46 in)
	0.254 mm (10 mils)	5.98 cm (2.35 in)	20.73 cm (8.16 in)
	0.381 mm (15 mils)	*	27.58 cm (10.86 in)
PDF417	0.168 mm (6.6 mils)	6.25 cm (2.46 in)	13.87 cm (5.46 in)
	0.254 mm (10 mils)	4.47 cm (1.76 in)	21.74 cm (8.56 in)
	0.381 mm (15 mils)	4.98 cm (1.96 in)	33.43 cm (13.16 in)

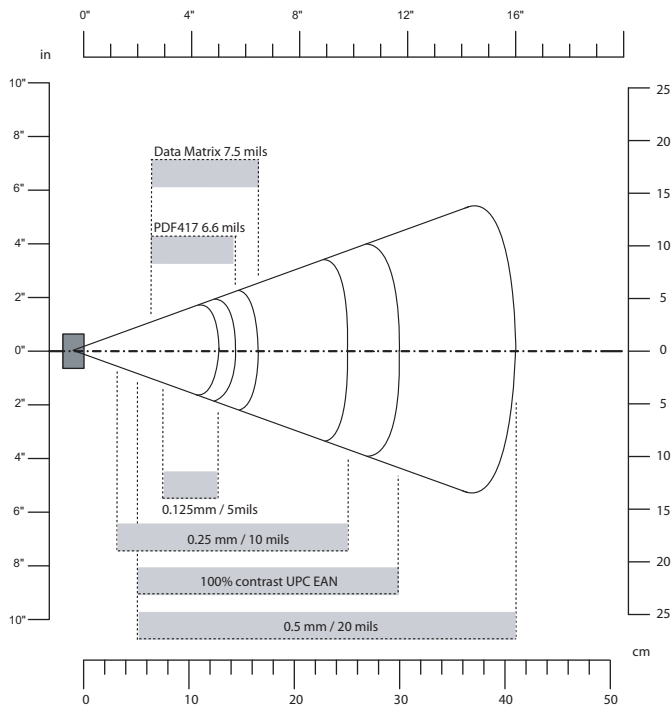

EA11 Standard Minimum Reading Distances

B

Default Settings

Default Configuration

The following tables list the default values of the configuration commands supported on the mobile computer. If you restore the computer to factory default settings, the computer uses these values.

The commands are grouped by function and reflect the organization of Intermec Settings. You can configure your computer with Intermec Settings from the SmartSystems Foundation console. For detailed information on most of the commands, see the *Intermec Settings Command Reference Manual*.

Data Collection

Symbology Settings

Symbology	Default Value
AustraliaPost	Disable
Aztec	Disable
BPO	Disable
CanadaPost	Disable
ChinaPost	Disable
Codabar	Disable
Codablock A	Disable
Codablock F	Disable
Code 11	Disable
Code 39	Enable
Code 93	Disable
Code 128/GS1-128	Enable
DataMatrix	Enable
DutchPost	Disable
EAN/UPC	Enable UPC A, UPC E, EAN 8, EAN 13
GS1 Composite	Disable
GS1 DataBar Expanded	Disable
GS1 DataBar Limited	Disable
GS1 DataBar Omnidirectional	Disable

Symbology Settings (continued)

Symbology	Default Value
Infomail	Disable
Interleaved 2 of 5	Disable
JapanPost	Disable
KoreanPost	Disable
Matrix 2 of 5	Disable
Maxicode	Disable
Micro PDF417	Disable
MSI	Disable
PDF417	Enable
Planet	Disable
Plessey	Disable
Postnet	Disable
QR Code	Disable
Standard 2 of 5	Disable
SwedenPost	Disable
Telepen	Disable
TLC 39	Disable

Symbology Option Settings

Symbology Option	Default Value
Preamble	None (disabled)
Postamble	None (disabled)
Global Symbology ID	Disable
Multicode	Disable

Imager Settings

Imager Setting	Default Value
Predefined Modes	1D and 2D Standard
Signature Image Capture	Disable
Document Imaging	Disable

Decode Security Settings

Decode Security Setting	Default Value
Consecutive Data Validation	0
Identical Consecutive Timeout	300 ms
Different Consecutive Timeout	0
Center Decoding	Disable
Center Decoding Tolerance	0

Communications

Communications Settings

Communications Setting	Default Value
Device Name	CS40xxxxxxxxxxx

Bluetooth Settings

Bluetooth Setting	Default Value
Bluetooth Power	Off
Bluetooth Discoverable	Disable
Bluetooth Connectable	Disable

802.11 Radio Settings

802.11 Radio Setting	Default Value
Allow Security Changes	Enable
Radio Measurement	0
Radio Enabled	Enable

Ethernet Adapter Settings

IP Settings	Default Value
DHCP	Enable
DHCP Client Identifier	Null
Primary DNS	0.0.0.0
Secondary DNS	0.0.0.0
Primary WINS	0.0.0.0
Secondary WINS	0.0.0.0

Certificates Settings

Certificates Setting	Default Value
Import Root Certificates	False
Import User Certificates	False
Import Pac Files	False

Ethernet Adapter IP Settings

Ethernet Adapter IP Setting	Default Value
DHCP	Enable
DHCP Client Identifier	Null
Primary DNS	Null
Secondary DNS	Null
Primary WINS	Null
Secondary WINS	Null

Device Settings

Device Settings

Device Setting	Default Value
Date	Null
Time	Null
Adjust for Daylight Time	Disable
Good Read Beep	One Beep

Appendix B – Default Settings

Device Settings (continued)

Device Setting	Default Value
Beeper Volume	Medium

C

Keypads and Keystrokes

Standard Characters

Use the following tables to learn how to enter standard and hidden characters and functions with the keypad.

Alphanumeric Characters

Character	QWERTY Keypad	Numeric Keypad
a	A	2
b	B	2 2
c	C	2 2 2
d	D	3
e	E	3 3
f	F	3 3 3
g	G	4
h	H	4 4
i	I	4 4 4
j	J	5
k	K	5 5
l	L	5 5 5
m	M	6
n	N	6 6
o	O	6 6 6
p	P	7
q	Q	7 7
r	R	7 7 7
s	S	7 7 7 7
t	T	8
u	U	8 8
v	V	8 8 8
w	W	9
x	X	9 9

Alphanumeric Characters (continued)

Character	QWERTY Keypad	Numeric Keypad
y		
z		
A		
B		
C		
D		
E		
F		
G		
H		
I		
J		
K		
L		
M		
N		
O		
P		
Q		
R		
S		
T		
U		
V		
W		
X		
Y		
Z		

Alphanumeric Characters (continued)

Character	QWERTY Keypad	Numeric Keypad
0		
1		
2		
3		
4		
5		
6		
7		
8		
9		

Characters and Functions

Function	QWERTY Keypad	Numeric Keypad
Forward Tab		
Back Tab		
Space		
Backspace		
Shift		or
Caps Lock		
Up Arrow		
Down Arrow		
Left Arrow		
Right Arrow		
!		Not available
@		Not available
#		
\$		Not available
%		Not available

Characters and Functions (continued)

Function	QWERTY Keypad	Numeric Keypad
&		Not available
*		
+		
ok		
-		
Start (Windows)		
?		Not available
:		Not available
/		Not available
=		Not available
‘ (apostrophe)		Not available
, (comma)		Not available
. (period)		
Esc		
Backlight		
Talk		
End call		

D

Imager Configuration Bar Codes

Imager Configuration Bar Codes

Use the following bar codes to quickly configure the mobile computer imager. These bar codes allow you to enable or disable symbologies, reset to factory defaults, and set predefined imager modes.

If you need to create a bar code for a specific setup, please download a free copy of EasySet from the CS40 web page on the Intermec web site at www.intermec.com.



Basic Configuration Bar Codes

Command	Bar Code
Disable all symbologies	
Reset to Factory Defaults	
Postamble with Carriage Return and Line Feed	

Imager Predefined Modes

Command	Bar Code
1D codes only	
Standard 1D and 2D codes	

Imager Predefined Modes (continued)









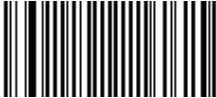
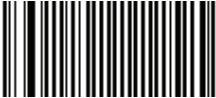

Command	Bar Code
1D and 2D codes bright environment	
1D and 2D codes with reflective surface	

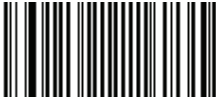
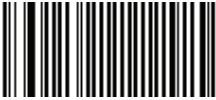
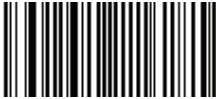
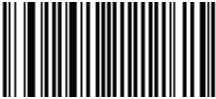
Symbology Bar Codes

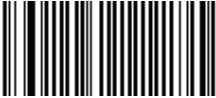
Symbology	Enable Bar Code	Disable Bar Code
AustraliaPost		
Aztec		
BPO		
CanadaPost		
Codabar		

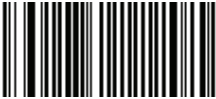
Appendix D – Imager Configuration Bar Codes

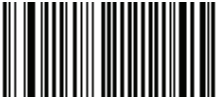
Symbology Bar Codes (continued)

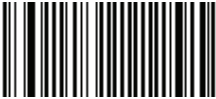





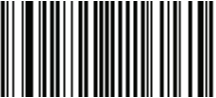
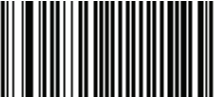

Symbology	Enable Bar Code	Disable Bar Code
Code 11		
Code 39		
Code 93		
Code 128		
DataMatrix		
DutchPost		
EAN 8		
EAN 13		

Symbology Bar Codes (continued)

Symbology	Enable Bar Code	Disable Bar Code
GS1 128		
Interleaved 2 of 5		
JapanPost		
Matrix 2 of 5		
MaxiCode		
Micro PDF417		
MSI Code		
PDF417		

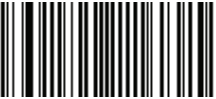
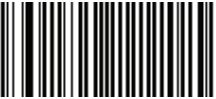
Appendix D – Imager Configuration Bar Codes

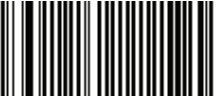
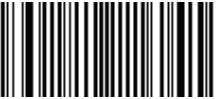
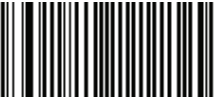
Symbology Bar Codes (continued)

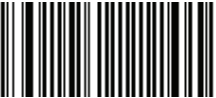
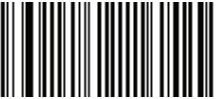
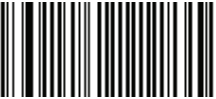
Symbology	Enable Bar Code	Disable Bar Code
Planet		
Plessey Code		
Postnet		
QR Code		
Standard 2 of 5		
Telepen		
TLC 39		
UPC-A		

Symbology Bar Codes (continued)

Symbology	Enable Bar Code	Disable Bar Code
UPC-E		
UPC-E1		

Appendix D – Imager Configuration Bar Codes



Worldwide Headquarters
6001 36th Avenue West
Everett, Washington 98203
U.S.A.

tel 425.348.2600

fax 425.355.9551

www.intermec.com

© 2010 Intermec Technologies
Corporation. All rights reserved.

CS40 Mobile Computer User's Manual



P/N 935-037-001