

70 Series

Mobile Computer

CK70, CK70NI, CK71, CK71NI, CN70, CN70NI, CN70e, CN70eNI



User Manual

Intermec Technologies Corporation

Worldwide Headquarters
6001 36th Ave.W.
Everett, WA 98203
U.S.A.

www.intermec.com

The information contained herein is provided solely for the purpose of allowing customers to operate and service Intermec-manufactured equipment and is not to be released, reproduced, or used for any other purpose without written permission of Intermec Technologies Corporation.

Information and specifications contained in this document are subject to change without prior notice and do not represent a commitment on the part of Intermec Technologies Corporation.

© 2011 by Intermec Technologies Corporation. All rights reserved.

The word Intermec, the Intermec logo, Norand, ArciTech, Beverage Routebook, CrossBar, dcBrowser, Duratherm, EasyADC, EasyCoder, EasySet, Fingerprint, i-gistics, INCA (under license), Intellitag, Intellitag Gen2, JANUS, LabelShop, MobileLAN, Picolink, Ready-to-Work, RoutePower, Sabre, ScanPlus, ShopScan, Smart Mobile Computing, SmartSystems, TE 2000, Trakker Antares, and Vista Powered are either trademarks or registered trademarks of Intermec Technologies Corporation.

There are U.S. and foreign patents as well as U.S. and foreign patents pending.

Wi-Fi is a registered certification mark of the Wi-Fi Alliance.

Microsoft, Windows, and the Windows logo are registered trademarks of Microsoft Corporation in the United States and/or other countries.

Bluetooth is a trademark of Bluetooth SIG, Inc., U.S.A.

Document Change Record

This page records changes to this document. The document was originally released as Revision 001.

Version Number	Revision Letter	Date	Description of Change
002	A	06/2011	Revised to add information on non-incendive (NI) versions of the computer, provisioning the computer, the new ScanDiagnostics application, and how to use the 70 Series as a USB mass storage device. Also corrected the cold boot procedure and removed the compass.

DRAFT

Contents

Before You Begin.....	xi
Safety Information.....	xi
Global Services and Support.....	xi
Warranty Information.....	xi
Web Support.....	xi
Send Feedback.....	xii
Telephone Support.....	xii
Service Location Support.....	xii
Who Should Read This Manual.....	xiii
Related Documents.....	xiii
Patent Information.....	xiv

1 Using the Computer..... 1

About the 70 Series Mobile Computers.....	2
What's New in This Release.....	4
Overview of 70 Series Features.....	5
About the Status LEDs.....	6
70 Series Accessories.....	8
About Language Provisioning.....	9
About the Battery.....	10
Charging the Battery.....	10
Changing the Battery.....	10
About Battery Status.....	13
About Battery Life and Conservation.....	15
About the Keypad.....	16
Entering Characters on the QWERTY Keypad.....	21
Entering Characters on the Numeric Keypad.....	22
Entering Characters on the CK70 and CK71 Keypads.....	23
About the Power Button.....	23
About the Intermec Dashboard Button.....	25
Configuring the Screen Backlight.....	26
Adjusting the Volume.....	26
Reading Bar Codes.....	27

Contents

Inserting a microSD Card.....	28
Installing a microSD Card in a CN70 or CN70e	28
Installing a microSD Card in a CK70 or CK71	31
Transferring Files To and From Your PC	33
Using Microsoft ActiveSync to Transfer Files	34
Using the Computer as a Mass Storage Device.....	35

2 Understanding the User Interface and Intermec Applications..... 37

About the User Interface.....	38
About the Home Screen	38
Interacting With the Screen.....	39
Title Bar Status Icons	40
Aligning the Screen	43
About Intermec Applications	43
Applications Available on the Mobile Computer	44
Applications You Can Download to the Mobile Computer.....	45

3 Using the Phone

About the Phone.....	50
Activating the UMTS Phone	50
Activating the CDMA Phone.....	52
Turning the Phone On and Off.....	53
Switching Network Carriers.....	54
Making a Phone Call	54
Making an Emergency Phone Call	54

4 Using the Camera..... 55

About the Color Camera.....	56
Taking a Picture	56
Recording a Video.....	57
Saving Pictures and Videos to an SD Card.....	57

5	Using GPS	59
	About the Integrated GPS on Your Computer	60
	Using the GPSID Installed on the Computer	60
	Improving GPS Performance on the Computer	61
6	Configuring the Computer	63
	How to Configure the Computer	64
	Using Intermec Settings on the Computer	64
	Starting Intermec Settings	65
	About the Structure of Intermec Settings	65
	Navigating in Intermec Settings	70
	Configuring Profile Settings With Intermec Settings	70
	Restoring Default Settings	71
	Hiding Menu Items in Intermec Settings	71
	Using Intermec Settings Remotely With SmartSystems Foundation	72
	About Network Communications	72
	Configuring 802.11a/b/g/n (Wi-Fi) Radio Communications	72
	Configuring Ethernet Communications	73
	Configuring Bluetooth Communications	74
	About Serial and USB Communications	77
	Creating an ISP Connection	78
	Creating a VPN Server Connection	80
	About Wireless Security	81
	Choosing Between Microsoft and Funk Security	81
	Loading a Certificate	90
7	Managing the Computer	93
	Managing the Computer in Your Network	94
	Managing the Computer Using SmartSystems	94
	Managing the Computer Using Third-Party Software	95
	Developing and Installing Applications	95
	Packaging Your Application	96
	Choosing a Target Location	96
	Installing Applications Using SmartSystems Foundation Console	96

Contents

Installing Applications Using Microsoft ActiveSync	97
Installing Applications Using a Storage Card	97
Launching Applications Automatically	97
Updating the System Software	98
Updating Multiple Computers Using SmartSystems Console	99
Updating Individual Mobile Computers	100
8 Troubleshooting and Maintaining the Computer	103
About the Intermec Dashboard	104
Troubleshooting Your Mobile Computer	105
Troubleshooting the Wi-Fi Connection	105
Troubleshooting 802.1x Security	106
Checking 802.11 Network Status	107
Troubleshooting Reading Bar Codes	109
Using ScanDiagnostic to Troubleshoot the Scanner	110
Troubleshooting Operating the Computer	111
Calling Product Support	112
Finding Your Configuration Number	112
Finding Your Operating System Version	113
Resetting the Computer	113
Rebooting the Computer	113
Cold Booting the Computer	113
Clean Booting the Computer	115
Cleaning the Computer	116
A Specifications and Default Settings	117
Physical and Environmental Specifications	118
CN70 Physical Dimensions	118
CN70e Physical Dimensions	118
CK70 Physical Dimensions	118
CK71 Physical Dimensions	118
Environmental Specifications	118
Power and Electrical Specifications	119
70 Series Non-Incendive Computer Specifications	119
Operating System	119
Hardware	119

Back Accessory Interface Pin-outs 120
Touch Screen Specifications 120
Standard Communications 120
Wireless LAN 120
Regulatory Approvals 121
Bar Code Symbologies 121
Imager Reading Distances 122
Default Configuration 130

B Keypads and Keystrokes 139

Standard Characters 140
 CN70 Keypads and Keystrokes 140
 CN70e Keypads and Keystrokes 145
 CK70 Keypads and Keystrokes 149

CK71 Keypads and Keystrokes 156

C ScanNGo Wi-Fi Configuration Bar Codes 165

Radio Configuration Bar Codes 166
 2D Configuration Bar Codes 166
 1D Configuration Bar Codes 167

I Index 175

DRAFT

Before You Begin

This section provides you with safety information, technical support information, and sources for additional product information.

Safety Information

Your safety is extremely important. Read and follow cautions in this document before handling and operating Intermec equipment. You can be seriously injured, and equipment and data can be damaged if you do not follow the safety cautions.

This section explains how to identify and understand cautions and notes that are in this document.



A caution alerts you to an operating procedure, practice, condition, or statement that must be strictly observed to prevent equipment damage or destruction, or corruption or loss of data.



Note: Notes either provide extra information about a topic or contain special instructions for handling a particular condition or set of circumstances.

Global Services and Support

Warranty Information

To understand the warranty for your Intermec product, visit the Intermec web site at www.intermec.com and click **Support > Returns and Repairs > Warranty**.

Disclaimer of warranties: The sample code included in this document is presented for reference only. The code does not necessarily represent complete, tested programs. The code is provided “as is with all faults.” All warranties are expressly disclaimed, including the implied warranties of merchantability and fitness for a particular purpose.

Web Support

Visit the Intermec web site at www.intermec.com to download our current manuals (in PDF).

Visit the Intermec technical knowledge base (Knowledge Central) at www.intermec.com and click **Support > Knowledge Central** to review technical information or to request technical support for your Intermec product.

Send Feedback

Your feedback is crucial to the continual improvement of our documentation. To provide feedback about this manual, please contact the Intermec Technical Communications department directly at TechnicalCommunications@intermec.com.

Telephone Support

In the U.S.A. and Canada, call **1-800-755-5505**.

Outside the U.S.A. and Canada, contact your local Intermec representative. To search for your local representative, from the Intermec web site, click **About Us > Contact Us**.

Service Location Support

For the most current listing of service locations, click **Support > Returns and Repairs > Repair Locations**.

For technical support in South Korea, use the after service locations listed below:

Awoo Systems

102-1304 SK Ventium
522 Dangjung-dong
Gunpo-si, Gyeonggi-do Korea, South 435-776
Contact: Mr. Sinbum Kang
Telephone: +82-31-436-1191
Email: mjyun@awoo.co.kr

IN Information System PTD LTD

6th Floor
Daegu Venture Center Bldg 95
Shinchun 3 Dong
Donggu, Daegu City, Korea
E-mail: jmyou@idif.co.kr or korlim@gw.idif.co.kr

Who Should Read This Manual

This manual is written for the person who is responsible for installing, configuring, and maintaining the 70 Series Mobile Computer.

This manual provides you with information about the features of the 70 Series mobile computer, and how to install, configure, operate, maintain, and troubleshoot it.

Before you work with the 70 Series mobile computer, you should be familiar with your network and general networking terms, such as IP address.

Related Documents

This is a list of related Intermec documents.

- *Intermec Settings Command Reference Manual*
- *Intermec Developer Library (IDL) Resource Kit Developer's Guide*

The Intermec web site at www.intermec.com contains our documents (as PDF files) that you can download for free.

To download documents

- 1** Visit the Intermec web site at www.intermec.com.
- 2** Click the **Products** tab.
- 3** Using the **Products** menu, navigate to your product page. For example, to find the CN70 computer product page, click **Computers > Handheld Computers > CN70**.
- 4** Click the **Manuals** tab.

If your product does not have its own product page, click **Support > Manuals**. Use the **Product Category** field, the **Product Family** field, and the **Product** field to help you locate the documentation for your product.

Patent Information

Product is covered by one or more of the following patents:

4882476; 4894523; 4953113; 4961043; 4970379; 4988852; 5019699;
5021642; 5038024; 5081343; 5095197; 5144119; 5144121; 5182441;
5187355; 5187356; 5195183; 5216233; 5216550; 5195183; 5195183;
5218191; 5227614; 5233172; 5241488; 5243602; 5258606; 5278487;
5288985; 5308966; 5322991; 5331136; 5331580; 5342210; 5349678;
5359185; 5371858; 5373478; 5389770; 5397885; 5410141; 5414251;
5416463; 5442167; 5464972; 5468947; 5468950; 5477044; 5486689;
5488575; 5500516; 5502297; 5504367; 5508599; 5514858; 5530619;
5534684; 5536924; 5539191; 5541419; 5548108; 5550362; 5550364;
5565669; 5567925; 5568645; 5572007; 5576529; 5592512; 5594230;
5598007; 5608578; 5616909; 5619027; 5627360; 5640001; 5657317;
5659431; 5671436; 5672860; 5684290; 5719678; 5729003; 5742041;
5761219; 5764798; 5777308; 5777309; 5777310; 5786583; 5793604;
5798509; 5798513; 5804805; 5805807; 5811776; 5811777; 5818027;
5821523; 5828052; 5831819; 5834753; 5834749; 5837987; 5841121;
5842070; 5844222; 5854478; 5862267; 5869840; 5873070; 5877486;
5878395; 5883492; 5883493; 5886338; 5889386; 5892971; 5895906;
5898162; 5902987; 5902988; 5912452; 5923022; 5936224; 5949056;
5969321; 5969326; 5969328; 5979768; 5986435; 5987192; 5987499;
5992750; 6003775; 6012640; 6016960; 6018597; 6024289; 6034379;
6036093; 6039252; 6064763; 6075340; 6095422; 6097839; 6102289;
6102295; 6109528; 6119941; 6128414; 6138915; 6149061; 6149063;
6152370; 6155490; 6158661; 6164542; 6164545; 6173893; 6195053;
6234393; 6234395; 6244512; 6249008; 6328214; 6330975; 6345765;
6356949; 6367699; 6375075; 6375076; 6375344; 6431451; 6435411;
6484944; 6488209; 6497368; 6532152; 6538413; 6539422; 6621942;
6641046; 6681994; 6687403; 6688523; 6732930

There may be other U.S. and foreign patents pending.

1

Using the Computer

This chapter introduces the 70 Series Mobile Computers with Windows® Embedded Handheld operating system. Use this chapter to learn about the basic features and functions of each computer, as well as the available accessories for it.

DRAFT

About the 70 Series Mobile Computers

The ergonomically designed Intermec 70 Series Mobile Computers are built on the Microsoft Windows Embedded Handheld operating system. They are lightweight, easy-to-use, and run most software developed for the Windows Embedded platform, including standalone, client-server, and browser-based applications.

The 70 Series family of computers consists of four different models: the CN70, CN70e, CK70 and CK71. The CN70 and CN70e have the same features except that the CN70e offers a larger keypad for data-input intensive applications. The CK70 and CK71 have most of the same features, but the CK71 offers a choice of imager options and does not offer a WWAN radio option (phone). For intrinsically safe environments, Intermec offers non-incendive (NI) models of each 70 Series computer. Throughout this manual, all versions of the mobile computer are referred to as 70 Series unless information is specific to a particular model of computer.

In most of the user's manual, pictures of the CN70 and CK70 represent the four models of the 70 Series computers.

CN70 Front View

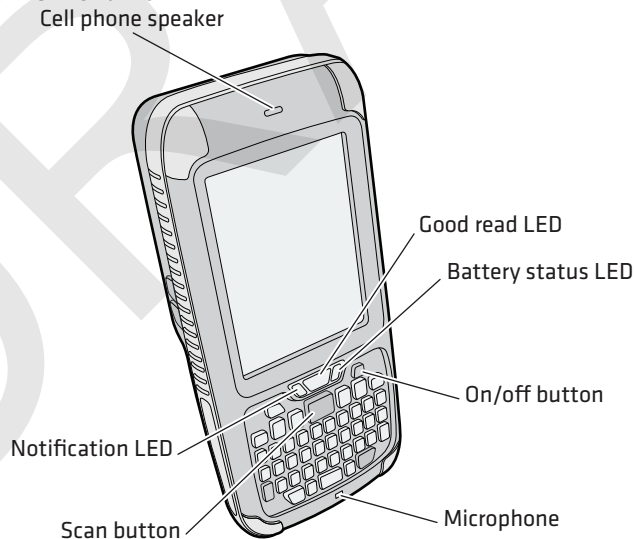

CN70 Back View

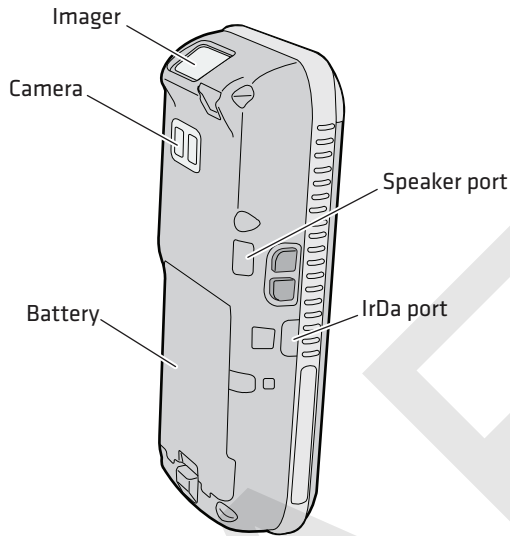

CK70 Front View



CK70 and CK71 Back View

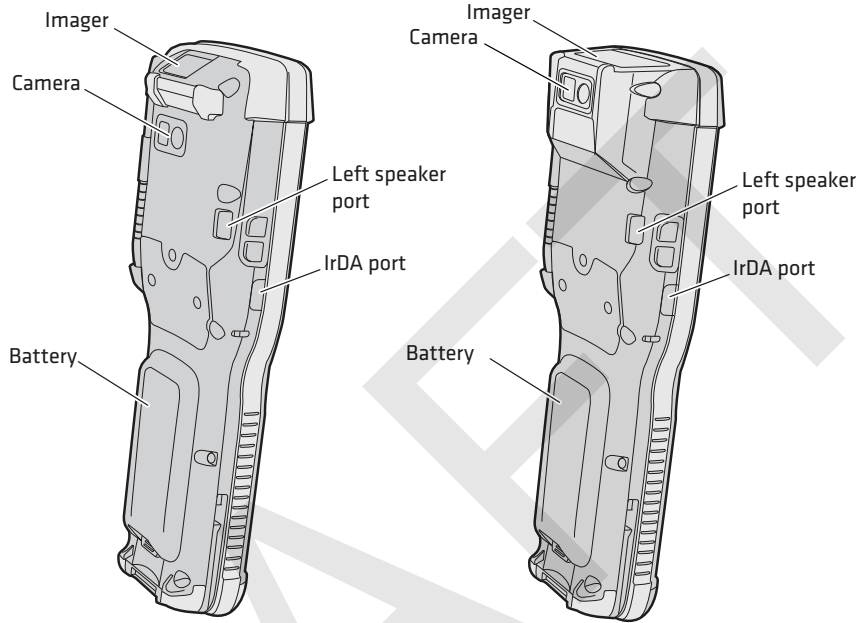

What's New in This Release

This version of the user's manual contains these updates:

Overview of 70 Series Features

The 70 Series includes these standard features:

- EA30 area imager that can read bar codes and capture images
- (CK71 only) Choice of EA30, EX25, or EV12 imagers
- Multi-processor architecture with 512 MB DRAM and 1G Flash
- CDMA, UMTS, or Flexible Network Radio capability (not available on CK71)
- 802.11a/b/g/n and Bluetooth® radios
- GPS radio on CDMA, UMTS, or Flexible Radio Network computers (not available on CK71)
- 5-megapixel auto-focus color camera
- Customer-accessible microSD slot for memory cards up to 32 GB
- Customer-accessible SIM card slot
- IrDA port with speeds up to 4 Mbps



The 70 Series Mobile Computer with an IEEE 802.11a/b/g/n radio installed is Wi-Fi® certified for interoperability with other 802.11a/b/g/n wireless LAN devices.

About the Status LEDs

Use the following illustrations and table to understand the status LEDs on your computer. All six status LEDs are not available on every 70 Series computer. For example, the QWERTY versions of the CN70 and CN70e do not have a Green key status LED.

Location of the CN70 Status LEDs

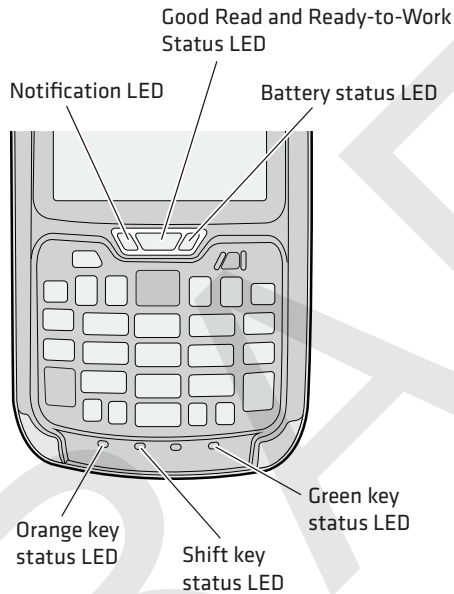

Location of the CK70 Status LEDs

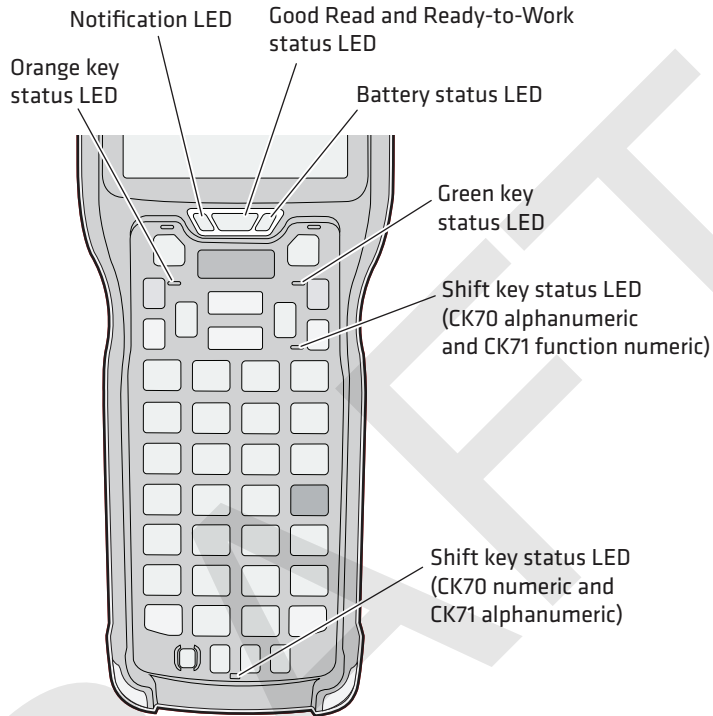

Status LED Descriptions

LED	Color	Description
Notification	Amber	This LED is user-programmable.
Good Read	Green	The computer successfully decoded a bar code.
Ready-to-Work	Blue	If you have Intermec Terminal Emulator (ITE), the application is running and connected to the host. If you do not have ITE, you can configure the Ready-to-Work indicator to turn on or off to indicate a healthy state.
	Blinking blue	ITE is running but not connected to the host.
Battery		See “About Battery Status” on page 13.
Key Status	Green	The Green function key is enabled.
	Orange	The Orange function key is enabled.
Shift	Red	The Shift key is enabled.

70 Series Accessories

The 70 Series computer ships with a battery. All other accessories are sold and ordered separately. For help, contact your local Intermec sales representative.

70 Series Accessories

Accessory	Description
Audio Snap-On Adapter	Use the audio adapter to connect the computer to a headset.
Back Accessory Interface	Use the back accessory interface to attach accessories such as the magstripe reader adapter to the CK70 and CK71.
CK70/CK71 Battery	This battery provides main power to the CK70 and CK71.
CK70/CK71 Magstripe Reader Adapter	Use the magnetic stripe reader to be able to read magnetic cards with the CK70 and CK71 computer.
CN70/CN70e Battery	This battery provides main power to the CN70 and CN70e.
CN70/CN70e Magstripe Reader Snap-On Adapter	Use the magnetic stripe reader to be able to read magnetic cards with the CN70 and CN70e computer.
Desktop Stand	Use the desktop stand to hold the 70 Series computer on your desk or a stable surface.
DEX/UCS Snap-On Adapter	Use this adapter to receive and send serial communications through a DEX/UCS connection.
DX1 Desktop Dock with USB connectivity	Use the desktop dock with the: <ul style="list-style-type: none">• Computer cup to charge the battery while it is installed in the computer.• Battery cup to charge the battery.
DX2 Dual Dock and DX4 Quad Dock. The DX2 and DX4 are available in charge-only and Ethernet configurations.	Use these charger bases with the: <ul style="list-style-type: none">• Computer cup to charge batteries while they are installed in the computer.• Battery cup to charge two batteries.

Accessory	Description
Ethernet Snap-On Adapter	Use the Ethernet adapter to be able to connect the computer to an Ethernet network.
Handstrap Replacement Kit	You can order and install a replacement handstrap for the CN70, CN70e, and CK70/CK71. Each kit contains 5 handstraps.
Holster	Use the holster to store the computer when you need your hands free.
RS-232 Snap-On Adapter	Use the RS-232 adapter to convert the connector on the bottom of the computer to a serial connector.
Scan Handle	Use the scan handle to provide better ergonomics to the computer for high-volume scanning applications.
Tethered Stylus Replacement Kit	You can order and install a replacement stylus.
USB Snap-On Adapter	Use this adapter to convert the bottom connector of the computer to a USB connector.
Vehicle Dock	Use the vehicle dock to provide power and hold your computer while you are using it in a vehicle.
Vehicle Holder	Use the vehicle holder to hold your computer while you are using it in a vehicle.
Vehicle Power Adapter	Use the vehicle power adapter to provide power to the computer from your vehicle.
Vocollect® Snap-On Adapter	Use this adapter to be able to use the Vocollect voice solution in your warehouse.

About Language Provisioning

If your 70 Series computer includes language provisioning, you are prompted to select a language provision when the computer starts for the first time. It may take up to 15 minutes to load your language.

Make sure you select the correct language before you tap **Provision**. If you need to have the language provisioning changed, you will need to send your computer to an Intermec Global Repair Center.

About the Battery

The computers use these rechargeable Lithium-ion battery pack as the main power source:

- 3.7 V, 4000 mAh (14.8 Wh) battery for the CN70 and CN70e
- 3.7 V, 5200 mAh (19.2 Wh) battery for the CK70 and CK71



The battery used in this device may present a fire or chemical burn hazard if it is mistreated. Do not disassemble it, heat it above 100°C (212°F) or incinerate it. Dispose of used batteries promptly. Keep away from children.

Charging the Battery

You need to fully charge the battery before using your computer for the first time. Use one of the charging accessories listed in the next table to charge the battery.

70 Series Charging Accessories

Charging Accessory	Charging Time
Snap-on adapters	Up to 6 hours
DX1, DX2, or DX4 dock	Up to 6 hours
CN70, CN70e, CK70, and CK71 Vehicle Power Adapter	Up to 6 hours

Changing the Battery

If your battery power is low, you need to either charge the battery in the computer, or replace it with a charged battery.

To change the battery:

- 1 Save your files and close any open applications.
- 2 Press the **Power** button and choose **Hibernate** from the menu to suspend the computer.

- 3** Detach the handstrap from the computer.

Detaching the Handstrap From a CN70 or CN70e

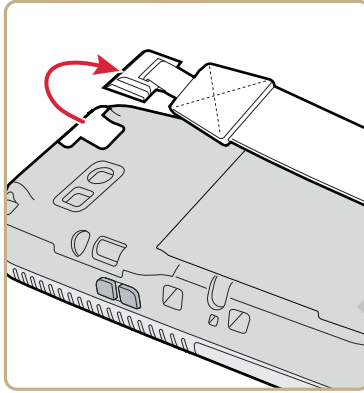

Detaching the Handstrap From a CK70 or CK71

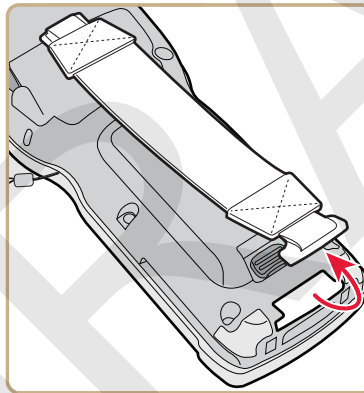

- 4** Make sure the computer is in hibernate mode and that the screen has turned off.
- 5** Remove the battery.

Chapter 1 – Using the Computer

- On the CN70 or CN70e, push the battery release toward the bottom of the computer until the battery releases and then lift it away from the computer.

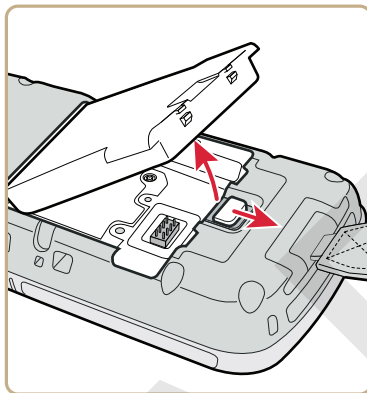

- On the CK70 or CK71, push the battery release toward the top of the computer until the battery releases and then lift it away from the computer.

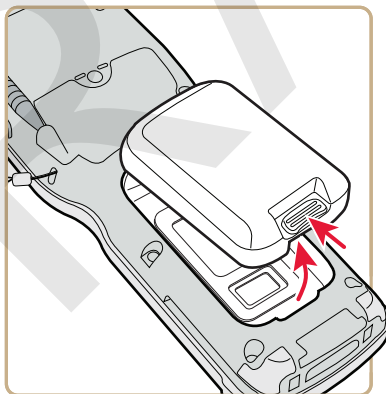







- 6 Insert the top end of a fully charged battery into the computer, and press down firmly on the bottom of the battery. Make sure that the battery release is fully engaged.

About Battery Status

Use the battery icon on the Title bar to see the power status of your battery. If you want more detailed information on your battery such as usage time or voltage, use the Intermec Dashboard. For more information on the Dashboard, see [“About the Intermec Dashboard” on page 104.](#)

Understanding the Battery Icon Status

Battery Icon	Status
	Battery is fully charged.
	Battery has a high charge.
	Battery has a medium charge. You should be able to work for several more hours before changing batteries.
	Battery is low. You need to charge or replace the battery soon.
	Battery is critically low. You need to replace the battery now.
	Battery is charging.
	The battery is not installed.

You can also use the battery status LED to see the charging status of your battery.

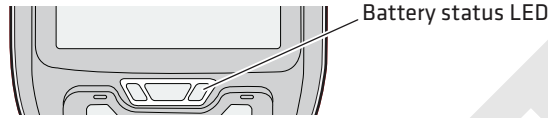

Understanding the Battery Status LED

LED State	Description
Steady green	The computer is connected to a charger and the battery is more than 95% charged.
Blinking red	The battery is very low. The computer will soon go into Suspend mode. Charge or replace the battery.
Steady red	The computer is connected to a charger and the battery is charging.
Blinking red-amber	The battery charging system has encountered an error. The battery is not charging.
Steady amber	The battery is outside of the allowable charging temperature range. Charging will resume when the battery temperature is back in the acceptable range of 0° to 45°C (32° to 113°F).
Off	The computer is not on external power and the battery is operating normally.

About Battery Life and Conservation

Batteries that are stored outside the computer for long periods of time slowly discharge. Intermec recommends storing the battery in a charger to maintain battery performance.

Battery Conservation Tips

When You Want To:	Do This to Save Battery Power:
Use the computer and the Low Battery status icon appears or the Battery light comes on.	<ul style="list-style-type: none"> • Connect the computer to an external power source. • Or, save your data and press the Power button and select Hibernate. After the computer turns off, remove the battery and insert a fully charged battery.
Stop using the computer for 5 minutes or longer.	Make sure that the low battery icon is not on the screen and the Battery LED is not on. Press the Power button and choose Suspend to suspend the computer.
Store the computer for more than a day.	<p>If you are storing the computer for a few days, like over the weekend, install a charged battery or connect the computer to a power source.</p> <p>If you are storing the computer for longer, remove and charge the battery, and then store both the battery and computer in a cool location. If you store the battery for several months, recharge the battery to keep it at peak performance.</p>
Store the battery outside the computer.	Store the batteries in a charger.

About the Keypad

The CN70 comes with either a QWERTY keypad or a numeric keypad. The CN70e comes with either a QWERTY numeric keypad or numeric keypad. The computer has an ambient light sensor that detects low light and turns on the keypad backlight. By default, the keypad backlight is enabled in low light conditions. You can disable the keypad backlight to conserve power. Use Intermec Settings to configure the backlight. For help, see [“Using Intermec Settings on the Computer” on page 64.](#)

CN70 QWERTY Keypad



CN70 Numeric Keypad



CN70e QWERTY Numeric Keypad



CN70e Numeric Keypad



The CK70 comes with either a large alpha or an alphanumeric keypad. The CK71 comes with either a numeric function keypad or an alphanumeric keypad. The computer has an ambient light sensor that detects low light and turns on the keypad backlight. By default, the keypad backlight is enabled in low light conditions. You can disable the keypad backlight to conserve power. Use Intermec Settings to configure the backlight. For help, see [“Using Intermec Settings on the Computer” on page 64](#).

CK70 Large Alpha Keypad





CK70 Alphanumeric Keypad



CK71 Numeric Function Keypad



CK71 Alphanumeric Keypad**Entering Characters on the QWERTY Keypad**

You need to use the orange modifier key  and the Shift key  to access all characters and functions on the QWERTY keypad.

To type a character:

- Press the key for that character.

To type a character or access a function on the overlay:

- Press  and then press the key for the character or function.



To only type characters or access functions on the overlay:

- Press  twice to lock the orange modifier key to stay on, and then press the keys for the characters or functions.

To type a single uppercase letter:

- Press  and then the letter key.

To type all uppercase letters:

- Press   to turn on Caps Lock, and then press the letter keys.

You can still type orange modifier characters by pressing  and then the key for that character.

To turn off Caps Lock, press .

Entering Characters on the Numeric Keypad

You need to use the orange modifier key  and the green modifier key  to access all characters and functions on the Numeric keypad.

To type a character or access a function printed in orange on the overlay:

- Press  and then press the key for the character or function.











To type a character or access a function printed in green on the overlay:

- Press  and then press the key for the character or function.



To type letters in the upper right corner of a key:

- Press  and then press the key one to three times depending on the position of the letter.

For example, in the upper right corner of the  key there are the letters “ABC”:

- To type “c”, press    .
- To type “C,” press   and then press    .

To only type letters:

- Press   to lock the green modifier key, and then press the key one to four times depending on the position of the letter.

While the green modifier key is locked, press  to toggle between only uppercase and lowercase letters.

To unlock the green modifier key, press .



Note: If uppercase letters are enabled and you unlock the green modifier key, you may need to press **⌘** **1** to type lowercase letters.

Entering Characters on the CK70 and CK71 Keypads

You need to use the orange modifier key **⌘**, the green modifier key **⌘**, and the Shift or Caps Lock key **⇧** to access all characters and functions on the Alpha, Alphanumeric, and Numeric Function keypads.

To type a character or access a function printed in orange on the overlay or in the upper left corner of a key:

- Press **⌘** and then press the key for the character or function.

To type a character or access a function printed in green on the overlay:

- Press **⌘** and then press the key for the character or function.

To type a single uppercase letter:

- Press **⇧** and then the letter key.

To type all uppercase letters:

- Press **⇧** **⇧** to turn on Caps Lock, and then press the letter keys.

You can still type orange or green modifier characters by pressing **⌘** or **⌘** and then the key for that character.

To turn off Caps Lock, press **⇧**.

About the Power Button

When you press the **Power** button, a dialog appears with a list of power options. If you do not select a power options setting, the currently selected action (the button outlined in bold) occurs after the timeout.

The Intermec Power Options Default Screen

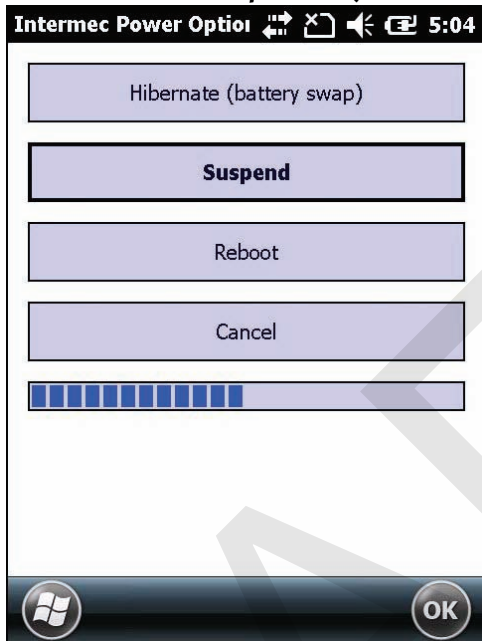

Use the following table to understand the Intermec Power Options.



Note: The Real Time Clock (RTC) will persist through all of the power options as long as it receives power from the Real Time Clock battery.

Intermec Power Options

Option	Description
Hibernate (battery swap)	High power saving mode. Use this setting only for swapping the battery. The computer saves the current system state, registry, and file system and then powers off all radios and internal devices. You can wake the computer by pressing the Power button or connecting the computer to external power.
Suspend	Medium power saving mode. The computer powers off all radios and internal devices not involved in saving the system state, but the phone stays on to receive calls. This option is the default setting. You can wake the computer by pressing the Power button, pulling the scanner trigger, receiving a call, scheduling an event such as an alarm, or by connecting external power.

Option	Description
Reboot	The computer does not save the current system state, but the registry and file systems are saved. The computer shuts down all running processes and restarts.
Cancel	The Power Options menu is cancelled.
Screen Off	Lowest power saving mode. The screen turns off, but the phone, all radios, and internal devices stay on. Tap the screen to turn the screen back on.
Shutdown	Very high power saving mode. The computer turns off everything. You must press Power or apply external power to restart the computer.

The Intermec Power Options screen is customizable. You can use Intermec Settings to determine which options are available to end users, the timeout until the default choice is selected, the default action if no option is selected, or to disable the Power Options screen. For more information on customizing the screen using Intermec Settings, see [“Using Intermec Settings on the Computer” on page 64](#) or see the *Intermec Settings Command Reference Manual*.

About the Intermec Dashboard Button

If the Ready-to-Work light blinks, your computer may be experiencing a problem. Press the Intermec Dashboard button (Ⓢ) to launch the Intermec Dashboard application and view troubleshooting and status information.

You can press the Ⓢ button at any time to bring up the Intermec Dashboard. If the computer is not healthy, the current issues are displayed at the top of the screen. If the device is healthy, you can use the Dashboard to view device information. For more information, see [“About the Intermec Dashboard” on page 104](#).

Configuring the Screen Backlight

The display has an ambient light sensor that automatically adjusts the backlight intensity to conserve power and ensure the display is readable.

By default, the screen turns off when there is no activity with the computer. Press a key or tap the screen to resume activity.

To configure the screen backlight to turn off:

- 1 Tap **Start > Settings > Power**.
- 2 Tap **Advanced** on the horizontal scroll bar.
- 3 Select the screen power off settings for when the computer is on battery power or external power.

To configure the screen brightness:

- 1 Tap **Start > Settings > System > Backlight**.
- 2 Adjust the slider to the desired brightness level.
- 3 Tap **OK**.



Adjusting the Volume

You can adjust the computer volume for your needs and your environment. The volume includes sounds you hear when you tap the screen or read bar codes with the imager. You can set the volume to off, very low, low, medium, high, very high (default), or vibrate.

You can also use the buttons on the right side of the computer to adjust the volume:

- The upper button increases the volume.
- The lower button decreases the volume.

To adjust the volume:

- 1 Tap the Volume icon at the top of the screen, and then tap the volume icon on the horizontal scroll menu.
- 2 Use your stylus or the  and  keys to adjust the volume slider to the volume you want, select **Vibrate**, or select **Off**.

Reading Bar Codes

The computer ships with an internal imager. Depending on the imager model in your computer, you can read 1D and 2D bar code symbologies, composite symbologies, and postal codes.

You can also connect the computer to:

- cordless scanners, such as the SF51 and SR61 through Bluetooth communications. For help, see **“Connecting to a Bluetooth Scanner” on page 74.**
- tethered scanners, such as the SR30, and SR61T through the RS-232 adapter (Model 1000AA03). For help, see **“Connecting to a Tethered Scanner” on page 78.**



Note: When the Pictures & Videos application is running, you cannot use the imager.

To read a bar code:

- 1 Enable only the bar code symbologies that you need.
- 2 Use Intermec Settings to choose the predefined imager mode that best suits your environment:

Predefined Mode	For Scanning
1D	Only 1D labels.
1D and 2D Standard	(Default) All types of bar code labels.
1D and 2D Bright Environment	In high ambient light, such as outdoors in the sunshine.
1D and 2D Reflective Surface	Glossy labels.



Note: You can also select the imager predefined mode in Profile Settings by tapping **Start > Profile Settings > Scanning.**

- 3 Point the imager window at the bar code label, and hold the computer steady a few inches from the label.
- 4 Press the **Scan** button. The laser pointer and illumination beam or frame appear.

Scanning With the EA30 Imager

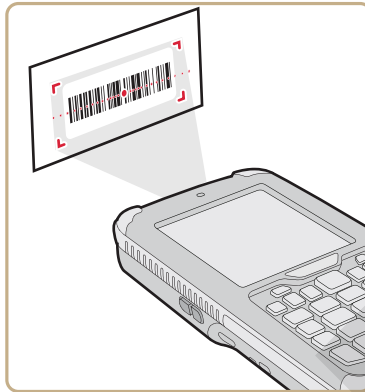

- 5 Use the laser pointer as a guide and aim toward the middle of the bar code. Make sure that the illumination beam or frame covers the bar code you are trying to decode.

When the computer successfully reads a bar code label, you hear a high beep, and the Good Read LED turns on briefly.

- 6 Release the **Scan** button.

Inserting a microSD Card

You can use a microSD™ card to increase file storage and install software. The computers support an optional 32 GB maximum capacity microSD card.



Note: The computer resets when you open the card access door to insert the microSD card. Make sure you completely close the card access door before you use your computer.

Installing a microSD Card in a CN70 or CN70e

To install a microSD card in a CN70 or CN70e:

- 1 Press the **Power** button to turn off the computer.
- 2 Remove the handstrap and the battery.

- 3** Remove the two Phillips screws and open the card access door.

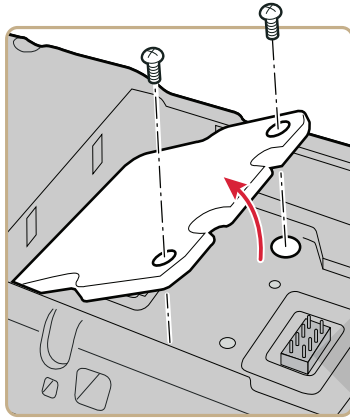

- 4** Slide the SIM card door to the left to unlock it and open the door.

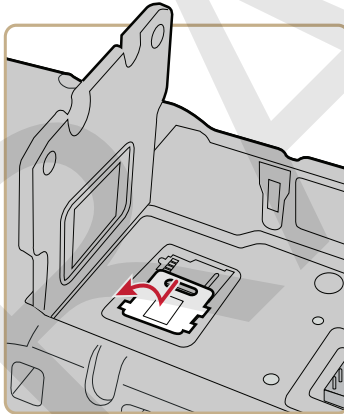

- 5 Slide the microSD card door towards the top of the computer to unlock it and open the door.

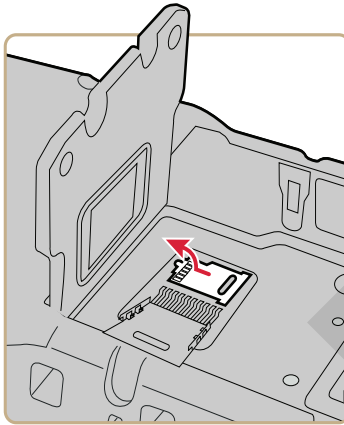

- 6 Slide the microSD card into place.

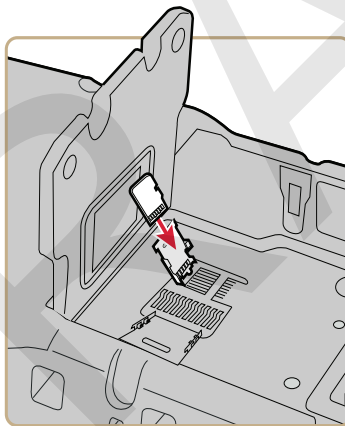

- 7 Close the microSD card door and slide it towards the bottom of the computer to lock it in place.
- 8 Close the SIM card door and slide it to the right to lock it in place.
- 9 Close the card access door and replace the two screws.
- 10 Install the battery. Press down firmly on the bottom of the battery, and make sure that the battery release tab is fully engaged.

- 11** Reattach the handstrap.
- 12** Press the **Power** button. The computer cold boots.

Installing a microSD Card in a CK70 or CK71

To install a microSD card in a CK70 or CK71:

- 1** Press the **Power** button to turn off the computer.
- 2** Remove the handstrap.
- 3** Remove the two screws that attach the interface adapter cover to the back of the computer.

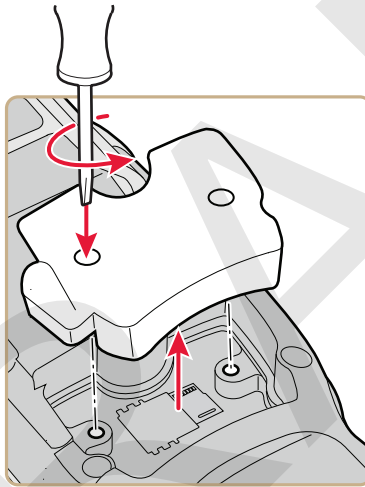

- 4 Slide the SIM card door to the left to unlock it and open the door.

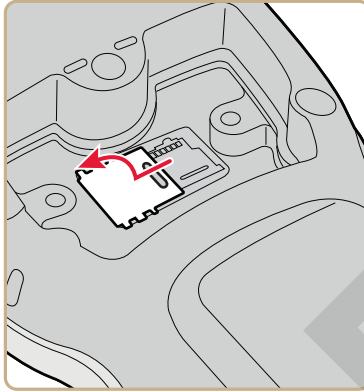

- 5 Slide the microSD card door towards the top of the computer to unlock it and open the door.

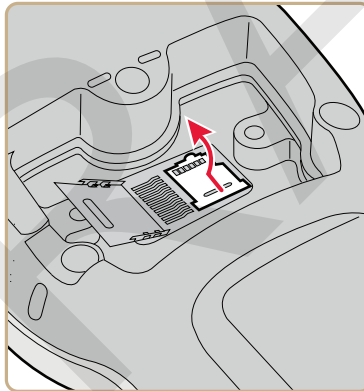

- 6 Slide the microSD card into place.

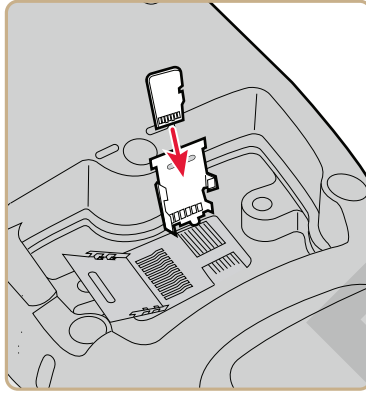

- 7 Close the microSD card door and slide it towards the bottom of the computer to lock it in place.
- 8 Close the SIM card door and slide it to the right to lock it in place.
- 9 Replace the interface adapter cover and attach with the two screws removed in Step 2.
- 10 Install the battery. Press down firmly on the bottom of the battery, and make sure that the battery release tab is fully engaged.
- 11 Reattach the handstrap.
- 12 Press the **Power** button. The computer cold boots.

Transferring Files To and From Your PC

The 70 Series computer supports these two methods for transferring files to and from your PC:

- Using Microsoft ActiveSync or Windows Mobile Device Center.
- Using the 70 Series computer as a mass storage device.

Using Microsoft ActiveSync to Transfer Files

You can use Microsoft ActiveSync (Windows XP or earlier) or Windows Mobile Device Center (Windows Vista or Windows 7) to establish a connection between your computer and a PC. After you connect to your PC, you can transfer files, synchronize files, remotely debug, and perform other device management activities. ActiveSync and Windows Mobile Device Center are free applications available from the Microsoft web site at www.windowsmobile.com/getstarted.

To establish a partnership between your computer and a PC, you need to physically connect your computer to your PC using these accessories:

- USB snap-on adapter (Model 1000AA07)
- USB cable

To transfer files to and from your PC using ActiveSync:

- 1 Connect your mobile computer to your desktop PC using the adapter and USB cable.
- 2 Download ActiveSync from the Microsoft web site and install ActiveSync on your PC.
- 3 Follow the onscreen instructions to establish a partnership. When the partnership is established, the Microsoft ActiveSync screen appears on your PC.

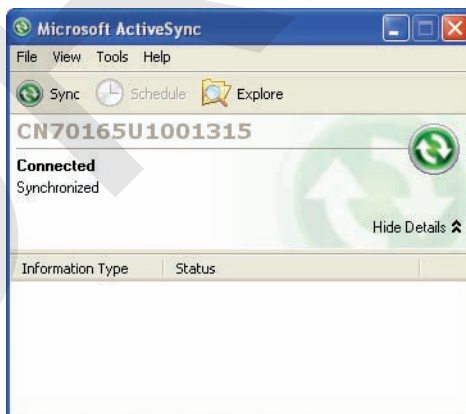

Using the Computer as a Mass Storage Device

You can connect the 70 Series computer as a mass storage device to your desktop PC. When connected as a mass storage device, you can easily copy files to and from the mobile computer.

To use the mobile computer as a mass storage device:

- 1 Go to www.datalight.com and download the Reliance Nitro Windows Driver (RNWD). You will need to login before you can download the driver.
- 2 Connect the mobile computer to your desktop PC using a USB cable.
- 3 Open Intermec Settings on the mobile computer by tapping **Start > Settings > System > Intermec Settings**.
- 4 From the Intermec Settings Main Menu, tap **Device Settings > USB Connections**.
- 5 From the USB Connections menu, select **Mass storage - Flash File Store** and tap **OK**.
- 6 Copy files to and from your desktop PC to the mobile computer.

DRAFT

2

Understanding the User Interface and Intermecc Applications

Use this chapter to learn about the Windows Embedded Handheld user interface and how to interact with the screen. You can also use this chapter to learn about the Intermecc applications on your computer, as well as additional Intermecc applications you can download.

About the User Interface

The user interface for the Windows Embedded Handheld 6.5 operating system is different from previous versions of Windows Mobile. The interface is touch-friendly and easy to navigate. Use the following sections to understand how to interact with Windows Embedded Handheld 6.5.

About the Home Screen

When you turn on your mobile computer, the Home screen is the first screen that appears. The Home screen contains three navigation bars: the Title bar, the horizontal scroll bar, and the Tile bar.

The Windows Embedded Handheld 6.5 Home Screen

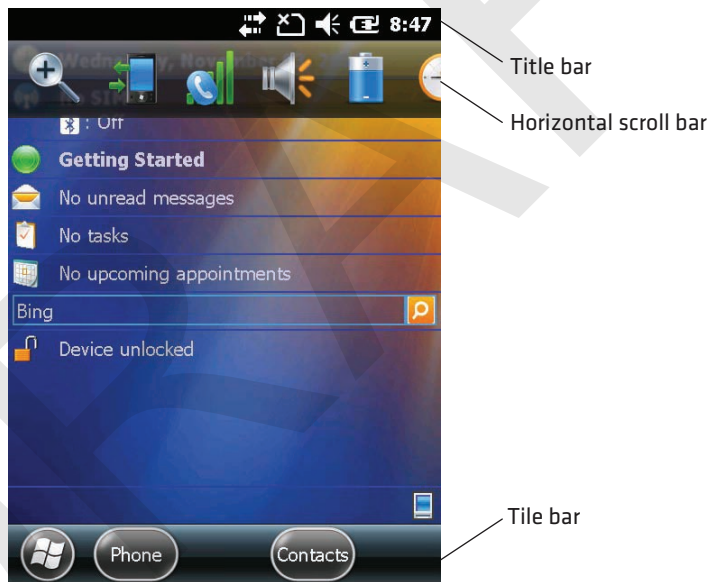

Use the Title bar icons to view the current status of information such as signal strength and battery power remaining. For more information on the Title bar icons, see **“Title Bar Status Icons” on page 40**.

A horizontal scroll bar appears when you tap an icon in the Title bar. This horizontal scroll bar makes it easy to access the applications associated with the Tile bar icons. The horizontal scroll bar also contains a magnifier which improves the touch experience by making parts of the screen large enough to tap with your finger.

The horizontal scroll bar also replaces tabs within Windows screens and allows for easier navigation.

Clock & Alarms Screen With Horizontal Scroll Bar

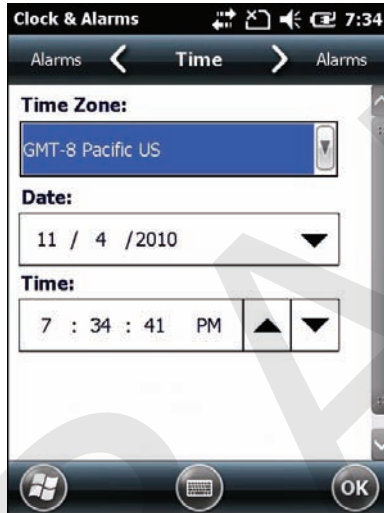

Use the Tile bar to navigate between screens and within applications. The icons available on the Tile bar change depending on the application you are using.

Interacting With the Screen

The Windows Embedded Handheld 6.5 interface supports the use of gestures with the finger or stylus to move around the screen. The table below explains the supported gestures.













Gesture	Description
Tap	Represents the left click of a mouse.
Double-tap	Represents the left double-click of a mouse.
Hold	Represents the right click of a mouse when you press and hold on the screen and a context menu appears.



















Gesture	Description
Flick	Initiates scrolling in the direction (horizontal or vertical) the finger or stylus moves across the screen.
Pan	Press and hold on the screen and then drag in any direction.



















Title Bar Status Icons









Tappable icons in the Title bar immediately show you the status of your network, your phone, the volume, the battery, and the time. Use the following table to understand what the icons mean.

Title Bar Status Icon Descriptions

Icon	Description
	You have a new notification.
	You have a new text message.
	You have a new e-mail message.
	You have a new instant message.
	You missed a call.
	The speakerphone is on.
	The phone is roaming.
	An alarm is set.
	The microphone is on.
	An internet call is in progress.
	A Bluetooth headset is detected.
	An ActiveSync connection has been established.
	There is a problem with the ActiveSync synchronization.

Icon	Description
	An ActiveSync synchronization is in progress over USB.
	A UMTS network is available.
	Connecting to a UMTS network.
	A UMTS connection is active.
	A 3G+ network is available.
	An EDGE network is available.
	Connecting to an EDGE network.
	An EDGE connection is active.
	A GPRS network is available.
	Connecting to a GPRS network.
	A GPRS connection is active.
	An HSDPA network is available.
	Connecting to an HSDPA network.
	An HSDPA connection is active.
	Bluetooth is on.
	Wi-Fi is on but not connected, and no networks are detected.
	Wi-Fi is not connected to a network, and other networks are detected.
	Other wireless networks are detected.
	Connected to a wireless network.

Icon	Description
	Synchronizing through a Wi-Fi connection.
	Connected to a wireless network, and other networks are detected.
	Information about a new wireless network is available.
	A network connection is active.
	A network connection is inactive.
	The phone has maximum signal strength.
	The phone has no signal.
	The phone capability is off.
	The phone has no service.
	The phone is searching for service.
	Data is being transferred.
	A voice call is in progress.
	A voice call is on hold.
	There is no SIM card present in the computer.
	The volume is off and the phone is set to vibrate.
	The volume is on.
	The volume is off.
	The battery has a full charge.
	The battery has a high charge.

Icon	Description
	The battery has a medium charge.
	The battery has a low charge.
	The battery has a very low charge.
	The battery is attached to external power and is charging.
	No battery is installed in the computer.
	Call forwarding is on.
	Voice mail is off.
	GPS locator is off.
	GPS locator is on.

Aligning the Screen

You may need to align your screen if you tap on one area and it registers in a different part of the screen. Make sure you only use the stylus to complete the alignment process.

To align the screen:

- 1 Tap **Start (⊞)** > **Settings** > **System** > **Screen**.
- 2 Follow the prompts on the screen to complete the alignment process.







About Intermec Applications





Intermec provides many useful applications to help you configure, troubleshoot, and connect your computer to other devices and networks. You can also download additional applications from the Intermec web site to help you use all of the features of your computer.

Applications Available on the Mobile Computer

Use this table to understand some of the Intermec applications available on your computer.

Intermec Applications Available on the Mobile Computer

Icon	Application	Description
	Bluetooth Audio	Use the Bluetooth Audio application to connect to a Bluetooth headset or hands-free device. For more information, see “Connecting to a Bluetooth Audio Device” on page 77.
	Carrier Selection	Use the Carrier Selection application to quickly change your network carrier. For more information, see “Switching Network Carriers” on page 54.
	iGPS	Use the iGPS application to improve the performance of GPS on your computer. For more information, see “Improving GPS Performance on the Computer” on page 61. iGPS is only available on computers with phone capability.
	Intermec Settings	Use Intermec Settings to configure your computer. You can use Intermec Settings to individually configure a computer or you can use it through SmartSystems to configure all of your computers. For more information, see “Using Intermec Settings on the Computer” on page 64.
	ISpyWiFi	Use ISpyWiFi to check your 802.11 status and diagnose issues with the connection. For more information, see “Checking 802.11 Network Status” on page 107.
	Profile Settings	Use Profile Settings to easily configure the computer for a specific use. You can choose predefined values for the Camera, Power, and Scanning. To apply a profile setting: <ul style="list-style-type: none"> • Tap the Profile Setting you want to use. You will see a message that changes are saved and a check mark appears next to your choice. For more information on modifying Profile Settings options, see “Configuring Profile Settings With Intermec Settings” on page 70.

Icon	Application	Description
	ScanDiagnostic	Use the ScanDiagnostic application to troubleshoot problems with the internal or external scanner. For more information, see “Using ScanDiagnostic to Troubleshoot the Scanner” on page 110.
	Wireless Center	Use the Wireless Center to turn radios (Wi-Fi, Bluetooth, phone) on and off and configure settings for each radio.
	Wireless Printing	Use the Wireless Printing application to connect to a Bluetooth printer. For more information, see “Connecting to a Bluetooth Printer” on page 76.
	Wireless Scanning	Use the Wireless Scanning application to connect to a Bluetooth scanner. For more information, see “Connecting to a Bluetooth Scanner” on page 74.

Applications You Can Download to the Mobile Computer

You can download several Intermec applications from the web site that extend the capabilities of your 70 Series computer. All of the applications listed below are available from the Intermec web site. Some of the applications require the purchase of a license to run. To find the application you want, go to www.intermec.com > **Support** > **Downloads** and then enter the information to find your 70 Series computer.

About eMDI

Intermec Enhanced Mobile Document Imaging Application (eMDI) is a professional document capture application that enables you to capture images of full page documents (8.5 x 11 or A4 paper sizes) with the camera. You can transfer the images from your mobile computer to a PC or server. For more information, see the [Intermec Enhanced Mobile Document Imaging User Guide](#). You can download and use eMDI for a 30-day evaluation period. After the evaluation period expires, you will need to purchase a license.

About Features Demo

Intermec Features Demo provides a simple way to explore the key features of your mobile computer. You will find applications that demonstrate scanning, document imaging, image capture, printing, and GPS functionality. Many of the applications that are part of Features Demo also have separate full-featured versions that you can download and license for your computer.

About Image Capture

The Intermec Image Capture application is provided for use on the 70 Series computers with an EA30 imager. Image capture provides a way for users to capture a high quality grayscale image with a mobile computer. Image Capture also allows you to change settings to provide the best image possible for the conditions present. You do not need to license Image Capture.

About Intermec Browser

Intermec Browser is a locked-down web application for your computer that is compatible with Internet Explorer 6.0. You can configure Intermec Browser for your specific application requirements and design your own web pages. You can download and use Intermec Browser for a 60-day evaluation period. After the evaluation period expires, you will need to purchase a license.

About Intermec Connection Manager

Intermec Connection Manager is a software application and API interface that provides seamless network roaming for Intermec mobile computers configured with one or more wired or wireless technologies (Ethernet, 802.11, GPRS, CDMA). Intermec Connection Manager works in the background to automatically establish and maintain connections. You can download and use Intermec Connection Manager for a 60-day evaluation period. the evaluation period expires, you will need to purchase a license.

About Intermec Launcher

Intermec Launcher is a Microsoft Windows application, designed for Intermec mobile computers, that provides a platform from which other applications may be launched while attempting to provide a locked-down environment. You can configure Intermec Launcher for your specific application requirements. You can download and use Intermec Launcher for a 60-day evaluation period. After the evaluation period expires, you will need to purchase a license.

About Intermec Terminal Emulator (ITE)

Intermec Terminal Emulator (ITE), part of Intermec Client Pack (ICP), is the next generation of Intermec's popular terminal emulation client designed for enterprise-level data collection. It provides a consistent user interface and a common menu structure to simplify the use and management of applications running on Intermec mobile and wireless computers.

ITE is packed with enhancements that improve productivity, reduce errors, and deliver fast return on investment. It supports multiple emulation protocols in a single client and has new features such as session persistence, remote management and configuration, and offers a maintenance plan to keep you up-to-date with the latest releases and upgrades. You can download and use ITE for a 60-day evaluation period. After the evaluation period expires, you will need to purchase a license and maintenance plan.

About SmartSystems Foundation

SmartSystems™ Foundation is an easy-to-use software platform that provides IT Administrators and Integrators a single, integrated portal for hands-free provisioning, deployment, and management of Intermec devices minimizing the effort spent on software upgrades, equipment monitoring, maintenance and troubleshooting.

SmartSystems Foundation provides a consistent way to manage Intermec devices including mobile computers, RFID readers, printers and bar code scanners, located on-site or remote, to make the most of limited IT resources, and lower the total cost of ownership for Intermec data collection equipment. SmartSystems Foundation can be downloaded at no charge from the Intermec web site. For more information, visit www.intermec.com/SmartSystems.

DRAFT

3

Using the Phone

You can use the phone feature to make and receive telephone calls, as well as transmit data through cellular wide-area networks (WANs).

DRAFT

About the Phone

The 70 Series mobile computer supports two types of cellular technology:

- CDMA
- UMTS

Phone features on the computer include a speaker and a microphone. You can also use a Bluetooth headset or hands-free kit. The phone feature is enabled by default on WWAN-equipped mobile computers.

After you turn on the phone and activate service with your wireless carrier, you can customize the phone features and network settings. For more information, see the online help on your mobile computer.

Activating the UMTS Phone

You use a SIM card to activate the UMTS phone on your computer. You can purchase the SIM card from your network provider.

To install the SIM card and activate the UMTS radio:

- 1** Press the **Power** button to turn off the computer.
- 2** On the CN70 or CN70e:
 - a** Push the battery release tab forward until the battery releases, and lift the battery away from the computer.
 - b** Remove the two Phillips screws and open the card access door.

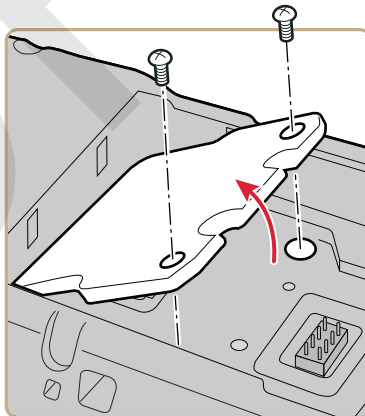

- 3** On the CK70, remove the two screws and lift the card access door away from the computer.

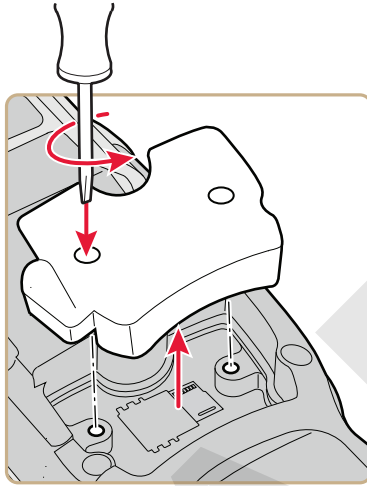

- 4** Slide the SIM card door to the left to unlock it and open the door.
- 5** Slide the SIM card into the slot in the card access door.

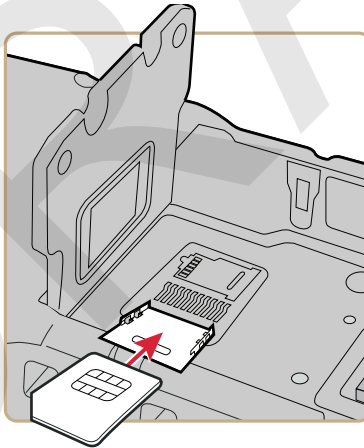

- 6** Close the SIM card door and slide it to the right to lock it in place.
- 7** Close the card access door and replace the two screws.

- 8 Install the battery. Press down firmly on the bottom of the battery, and make sure that the battery release tab is fully engaged.
- 9 Press the **Power** button. The computer cold boots.

Activating the CDMA Phone

To activate the CDMA radio module in your mobile computer, you need to contact your wireless carrier and set up an account for each mobile computer. The following table lists the carriers that Intermec currently supports. If your carrier is not listed in the table, please contact Intermec product support to see if it is now supported.

Currently Supported Carriers

Country	Carriers
United States	Sprint, Verizon

The carrier will require the Electronic Serial Number (ESN) to start the activation process. You can find the ESN:

- on a label located in the upper right corner of the battery compartment.
- on the outside of the computer shipping box.

The activation process is slightly different for each CDMA carrier. Your carrier sales contact and an Intermec representative can guide you through the process.

After you supply the ESN to your carrier, they will respond with values that you must enter using the Windows Mobile Activation Wizard (if required). Some of the supported carriers do not require you to enter any values. The following table shows the carriers, the correct activation method to use, and the values that you need to activate your phone.

Values Required for CDMA Phone

Carrier	Activation Method	Activation Values You Need
Sprint	Activation Wizard	<ul style="list-style-type: none"> • Master Subsidy Lock (MSL) or activation code • MDN • Mobile Station Identifier (MSID)
Verizon	<ul style="list-style-type: none"> • Dial *22899 • Activation Wizard 	None. All parameters are automatically transferred wirelessly.

After activation, the settings are permanently stored in the CDMA module. Changing the OS or SSPB loads will not affect any of the settings or activation parameters stored in the WAN modem.

Starting the Activation Wizard

Depending on your wireless carrier, you may need to use the Windows Mobile Activation Wizard to activate your phone.

To start the activation wizard:

- 1 Tap **Start > Phone**, or tap the **Phone** button on the Tile bar.
The phone application starts.
- 2 Tap **Menu > Activation Wizard**.

Turning the Phone On and Off

Before you can start using your phone, you need to enable it. You can use Wireless Center to enable and disable your phone, as well as Bluetooth and Wi-Fi communications.

To turn on the phone using Wireless Center:

- 1 Tap **Start > Settings > Connections > Wireless Center**.
- 2 Tap **Phone** to turn on the Phone
- 3 (Optional) To configure the phone, tap **Menu** in the tile bar at the bottom of the screen.
- 4 Tap **OK** when you are done configuring the options.
- 5 Tap **OK** to close Wireless Center.

Switching Network Carriers

Use the Carrier Selection application to quickly change your WWAN radio network carrier on your Flexible Radio Network enabled CN70, CN70e, or CK70 mobile computer.

To change the selected carrier:

- 1 Tap **Start** > **Carrier Selection**.
- 2 From the Carrier drop-down menu, select the new carrier and tap **OK**. A dialog box appears asking if you want to switch carriers.
- 3 Tap **Yes** to switch carriers.

If the update is successful, the Carrier Selection screen appears and displays the updated carrier information.

If the update is unsuccessful, a message box appears. Tap **Ok** to return to the Carrier Selection screen.

Making a Phone Call

After you activate your UTMMS or CDMA phone, you are ready to start making phone calls.

To make a phone call:

- 1 Press **Phone**.
- 2 Tap the keys to enter the telephone number you want to call, and tap **Talk**.

Making an Emergency Phone Call

You can use the UMTS phone to make an emergency phone call even if the SIM card is missing. When the SIM card is not installed, the phone will show that you have no service. However, if you dial certain emergency numbers (such as 112, 911, 000, 08, 118, 119, and 999) the call will go through.

4

Using the Camera

You can use the color camera to take pictures and record videos.

DRAFT

About the Color Camera

The camera and flash are located on the back of the computer. You run the Pictures & Videos application to access the camera features. In this application, you can:

- take, view, and edit pictures.
- record and launch video clips stored on the computer or a microSD card.
- configure camera options.

You can also send pictures and video clips to others or save an image as the background on the Home screen. If you download the eMDI application, it uses the camera to capture images.



Note: While the Pictures & Videos application is running, you cannot use the imager.

Taking a Picture

You can take photos in high, normal, or low quality, with image sizes up to 2048 x 1536 pixels. When you take a picture, the image is saved as a .jpg file and stored in the /My Documents/My Pictures folder.

To take a picture:

- 1** Tap **Start > Pictures & Videos**.
- 2** Tap the **Camera** icon in the grid or the **Camera** button on the Tile bar, or press **Enter**.
- 3** Using the screen as a viewfinder, move the camera until you have the image you want to take a picture of.
- 4** Press **Enter** to take and save the picture. If you choose to save your pictures to Main memory, they are saved to permanent storage on your mobile computer.

Recording a Video

You need to switch to video mode to record video. When you record video, the video is saved as an .mp4 file and stored in the /My Documents/My Pictures folder.

To switch to Video mode and record video:

- 1 Tap **Start > Pictures & Videos**.
- 2 Tap the **Camera** icon in the grid or the **Camera** button on the Tile bar, or press **Enter**.
- 3 Tap **Menu > Video**.
- 4 Using the screen as a viewfinder, move the video camera until you see the scene you want to video record.
- 5 Press **Enter** to start recording.
- 6 When you are done, tap **Stop** or press **Enter** to stop recording and save the video.

If you choose to save your videos to Main memory, they are saved to permanent storage on the computer.

Saving Pictures and Videos to an SD Card

Pictures and videos are automatically saved to the main memory on your computer. You can save your pictures and video to an SD card to easily transport them to another device.

To save picture and video files to an SD card:

- 1 Install a microSD card. For help, see [“Inserting a microSD Card” on page 28](#).
- 2 Tap **Start > Pictures & Videos**.
- 3 Tap the camera icon.
- 4 Tap **Menu > Options**.
- 5 From the **Save files to** list, select **SD card**, and tap **OK**.

DRAFT

5

Using GPS

The 70 Series computer comes equipped with an integrated Global Positioning System (GPS) receiver if your computer has phone capability (WWAN radio). The GPS receiver can deliver standards-based National Marine Electronics Association (NMEA) data strings to GPS applications.

About the Integrated GPS on Your Computer

Intermec recommends that you use the GPS Intermediate Driver (GPSID) instead of directly accessing the GPS hardware. The GPSID is a Microsoft software component that interacts between applications and the GPS hardware.

As a Microsoft software component, the GPSID:

- allows multiple applications to simultaneously access the GPS data stream.
- provides access to GPS data without requiring applications to recognize and parse NMEA syntax.

Using the GPSID Installed on the Computer

To use the GPSID installed on your mobile computer, you need to configure the GPSID settings.

To configure your GPSID settings:

- 1 Tap **Start > Settings > System > External GPS**. The GPS Settings screen appears with **Programs** selected.

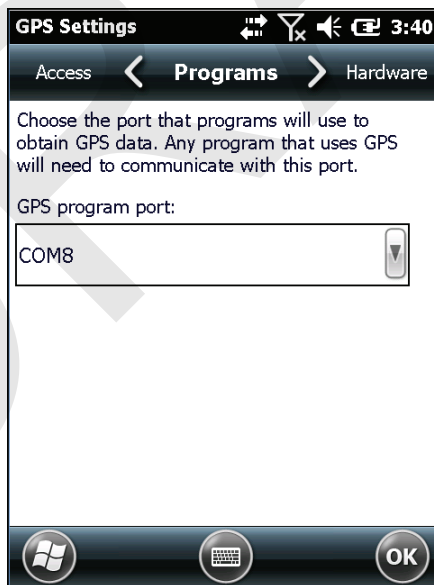

- 2 Select the COM port that you want your programs to use to get GPS data from your computer.
- 3 Tap **Access** in the horizontal scroll bar and select the **Manage GPS automatically** check box.

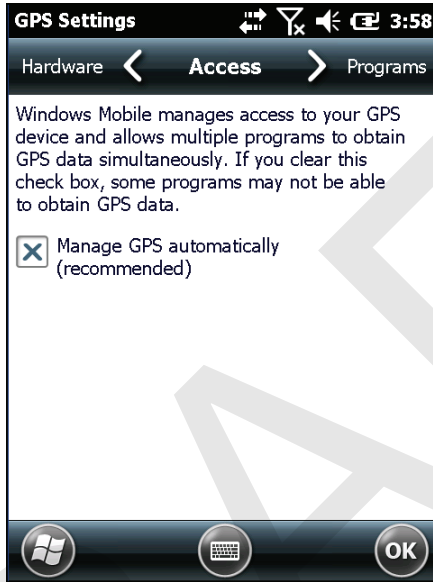

- 4 Tap **OK**.

Improving GPS Performance on the Computer

Use the iGPS application to improve the performance of the GPS on your CN70, CN70e, or CK70 computer. The integrated GPS module has three operating modes:

- Standalone
- MS Assisted
- gpsOneXTRA™ (UMTS computers only)

In Standalone mode, the GPS module relies solely on GPS satellites to determine position.

In MS Assisted mode, the computer can determine position without receiving GPS signals directly from satellites; instead, the computer receives GPS signals and information provided by the cellular network. Even when the computer can receive a satellite signal, MS Assisted can improve position accuracy and reduce the time to determine initial position (Time-To-First-Fix). Check with your cell phone carrier for availability and pricing for MS Assisted service.

Qualcomm's gpsOneXTRA Assistance technology provides enhanced operation for Standalone GPS. This option enables the UMTS-enabled computer to automatically download a small assistance data file from the XTRA servers through a brief internet access session.

Another option you can configure with iGPS is the fix interval. The fix interval defines how often the GPS should provide new information. Larger intervals use less power, but many applications require small intervals to work correctly. The default for fix interval is 4.



Note: Anytime you change the GPS settings, the phone module will reset automatically. It will not affect the functionality of the computer.

To improve GPS performance:

- 1 Go to **Start > Settings > System > iGPS**.
- 2 In the **Fix Interval** tab, enter a value for the fix interval. The default setting is 4 and should be optimized for most applications.
- 3 Tap the **Fix Type** tab and select one of these options: Standalone (1), MS assisted (2), or **Enable gpsOneXTRA** (check box).
- 4 Tap **OK**.

6

Configuring the Computer

Use this chapter to learn about the available methods for configuring your mobile computer and how to use Intermec Settings. You can also use this chapter to learn how to configure network communications and wireless security.

How to Configure the Computer

You can configure many parameters on the computer such as the bar code symbologies it decodes or the network settings. The values you set for these parameters determine how the computer operates.

There are several ways to configure the computer:

- Directly on the computer. You can use Intermec Settings directly on the computer to change only the settings on that computer. For more information, see **“Using Intermec Settings on the Computer” on page 64**.
- Remotely using Intermec SmartSystems Foundation. When you use SmartSystems, you can remotely configure all of your 70 Series mobile computers as well as other SmartSystems-enabled Intermec computers and peripherals. For more information, see **“Using Intermec Settings Remotely With SmartSystems Foundation” on page 72**.
- You can use a third-party device management product that supports the computer and Intermec Settings, such as Soti MobiControl or Wavelink Avalanche. For more information, visit the **Device Management** page on the Intermec web site.

You can also configure the computer with configuration bundles that you create using SmartSystems Foundation. For more information, see the SmartSystems Foundation Online Help.

Using Intermec Settings on the Computer

Use Intermec Settings to configure parameters for Intermec applications on the computer as well as some device-specific parameters like volume. You can configure parameters for important functions like data collection and communications.

Starting Intermec Settings

Intermec Settings is located on the System screen.

To start Intermec Settings:

- Tap **Start > Settings > System > Intermec Settings**.

The Intermec Settings Main Menu appears.

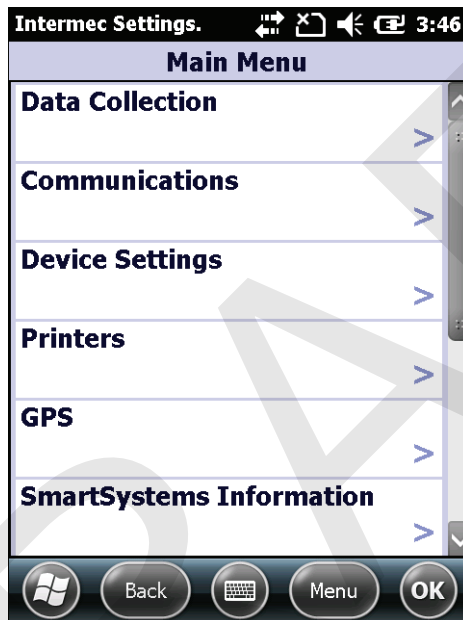

About the Structure of Intermec Settings

Use the tables below to help find the parameters in Intermec Settings that you want to configure. Each table contains the parameters for one of the Intermec Settings Main Menu options.

If you see > next to a menu option, there are more screens available in the next level. If you see ... next to a menu option, there is only one more screen available.

Most parameters are saved as soon as you tap **OK**. Some settings such as the Serial Port Switch require you to reboot the computer for the changes to take effect.

Data Collection Menu

Data Collection Options	Parameters You Can Configure
Internal Scanner	<ul style="list-style-type: none"> • Symbologies • Scanner settings • Imager settings • Decode security
Bluetooth Scanner	<ul style="list-style-type: none"> • Symbologies • Scanner settings • Imager settings • Decode security
Dock Tethered Scanner	<ul style="list-style-type: none"> • Symbologies • Scanner settings • Scanner port settings • Imager settings • Decode security
Camera	<ul style="list-style-type: none"> • Symbologies • Scanner settings • Camera settings • Decode security
BT-Configure on Connect	Bluetooth-configure on connect
Magstripe Reader	<ul style="list-style-type: none"> • Enable magstripe reader • Reader model (read-only)

Communications Menu

Communications Options	Parameters You Can Configure
Device Name	Device name
802.11 Radio	<ul style="list-style-type: none"> • Security choice (supplicant) • Security settings (includes Wi-Fi settings such as enable/disable radio) • IP settings • Certificates
Ethernet Adapter	IP settings
Bluetooth	Bluetooth settings (power, discoverable, connectable, and so on)

Communications Options	Parameters You Can Configure
WWAN Radio	<ul style="list-style-type: none"> • Add WWAN connection • Edit WWAN connections • Manage WWAN radio • Carrier Selection • WWAN information
Serial Port Switch	Serial port switch settings (IrDA, docking connector, and back interface)

Device Settings Menu

Device Settings Options	Parameters You Can Configure
Date and Time	Date and time settings
Good Read	<ul style="list-style-type: none"> • Internal scanner • Dock tethered scanner • Bluetooth scanner
Volume	Volume settings (beeper and voice, headset beeper, and vibrate mode)
Backlight	Backlight settings (display backlight, keypad backlight, and light level)
Screen	Screen rotation
Keypad	Scan button remapping
Power Management	<ul style="list-style-type: none"> • Power button • Battery power • External power
Sensors	<ul style="list-style-type: none"> • Screen rotation • Device off
USB Connections	USB connections
System Component Versions	System component versions (read-only)
IDL Runtime Versions	ITC50 (read-only)
Profile Settings Application	Whether these parameter options appear in Profile Settings: <ul style="list-style-type: none"> • Camera • Power • Scanning
Features Disabled by Policy	None (read-only)

Printer Menu

Printer Options	Parameters You Can Configure
Printer (if connected through Bluetooth)	Printer settings (Auto detect printer, memory, display, and so on)



Note: The Printer menu displays settings for Bluetooth connected printers. The settings that appear in the menu are dependent on the printer that is paired with the device. The printer needs to be using the Wireless Printer applet.

GPS Menu

GPS Options	Parameters You Can Configure
GPS	Bread crumbing settings

SmartSystems Information Menu

SmartSystems Information Options	Parameters You Can Configure
Identity	Identity information (hardware version, firmware version, OS version, and so on) (read-only)
Administrator	Administrator settings (name, phone, and email)
Location	Location settings (country, state, city, campus, and detail)
Information	Device Notes (read-only)

Virtual Wedge Menu

Virtual Wedge Options	Parameters You Can Configure
Enable Virtual Wedge	Enable virtual wedge
Bar Code Scanner Wedge	Bar code scanner wedge settings (bar code scanner grid and label encoding)
Magstripe Reader Wedge	Magstripe Reader Grid

Core Messaging Service Menu

Core Messaging Service Options	Parameters You Can Configure
Server IP	Server IP (read-only)
Associated Server IP	Associated server IP
Broadcast Name	Broadcast name
Port	Port (read-only)
Keep Alive Ping Interval	Keep alive ping interval

Device Monitor Menu

Device Monitor Options	Parameters You Can Configure
Device Health Controls	<ul style="list-style-type: none"> • Enable health data collection • Enable Blue light • Set rule file location • Set data refresh periods
Device Health Screen Captures	Device health screen capture settings (directory and screen capture allowed)
Disabled Executables	None (read-only)
Device Wipe	Device wipe settings (enable wipe and interval)

License Manager Menu

License Manager Options	Parameters You Can Configure
About	About settings (read-only)
License Vault	None (displays applications that are licensed)

Location Services Menu

Location Services Options	Parameters You Can Configure
Server	Server settings (port and enable server)
Virtual GPS	Virtual GPS settings

For more information on all parameters in Intermec Settings, see the *Intermec Settings Command Reference Manual*.

Navigating in Intermec Settings

You can easily navigate through the screens in Intermec Settings to find the parameter you need to configure.

To move down a level in Intermec Settings:

- Tap the menu item in the list.

To move back a level in Intermec Settings:

- Tap **Back** or **Cancel** on the Tile bar.

To save a parameter setting:

- Tap **OK**.

To exit Intermec Settings:

- Tap **Menu** > **Exit** or **OK**.

Configuring Profile Settings With Intermec Settings

A profile is a set of predefined values that you can easily apply to the computer to ensure optimal performance in a specific scenario. The end user does not need to figure out the “right” settings because we have already done that work for you. Profile Settings is available from the Start menu so you can make it available to the end user for easy configuration.

Use Intermec Settings to determine the profiles you want the end user to see in the Profile Settings application.

To configure the profile information an end user can access:

- 1** Go to **Device Settings** > **Profile Settings Application**.
- 2** Select **Camera**, **Power**, or **Scanning**.
- 3** From the Camera, Power, or Scanning submenu, check or clear the **Display** check box for the settings you want to have available to the end user.
- 4** Click **OK** to save your selection.

Restoring Default Settings

You can easily restore a menu to its default settings or all of the Intermec Settings parameters to their default settings if necessary.

To restore menu defaults:

- 1 Navigate to the menu that you want to restore to defaults.
- 2 Tap **Menu > Restore Menu Defaults**.
- 3 When prompted, tap **Yes** to restore the menu default settings.
- 4 If prompted to refresh the computer, tap **Yes**.

To restore all defaults:

- 1 Tap **Menu > Restore All Defaults**. The application asks if you are sure you want to restore all defaults.
- 2 Tap **Yes**.

After several minutes, all of the default settings are restored.

Hiding Menu Items in Intermec Settings

You can hide items in the Intermec Settings menus if you do not want to have them available for other users to access. Hidden items are not saved when you back up your settings in the SmartSystems console.

On the mobile computer, you can:

- hide menu items by tapping and holding the item, and then choosing **Hide Menu Item** from the popup list. When asked if you want to hide the menu, tap **Yes**.
- restore all hidden items in all menus, by tapping **Menu > Unhide All Items**.

 **Note:** When you restore default settings in Intermec Settings, only the settings for visible items are restored to defaults. The settings for hidden menu items are not affected.

Using Intermec Settings Remotely With SmartSystems Foundation

Your mobile computer is SmartSystems-enabled, which lets you open Intermec Settings from the SmartSystems console to remotely configure all of your mobile computers. For more information on SmartSystems, see “[Managing the Computer Using SmartSystems](#)” on page 94.

To open Intermec Settings from the SmartSystems console:

- 1 In the SmartSystems console, select a mobile computer and right-click.
- 2 From the menu, select **Intermec Settings**.
- 3 Configure the settings you need to change. As you choose parameters from the tree structure, help for each parameter appears in the upper right pane of Intermec Settings.
- 4 When you are done making changes, choose **File > Save Settings**.

For help using Intermec Settings, click **Help > Contents**. For information on all of the parameters in Intermec Settings, see the [Intermec Settings Command Reference Manual](#).

About Network Communications

You can easily add the mobile computer to your wireless or wired data collection network. You can connect your computer using:

- 802.11a/b/g/n radio communications.
- Ethernet communications.
- Bluetooth communications.
- USB and serial communications.

Configuring 802.11a/b/g/n (Wi-Fi) Radio Communications



Caution

Make sure all components with antennas are at least 30 cm (1 ft) apart when power is applied. Failure to comply could result in equipment damage.

The mobile computer contains an 802.11 radio to transfer data using wireless communications and to support the TCP/IP network protocols. This section of the manual assumes that your wireless network is set up, including your access points.

By default, the 802.11 radio is disabled. Use the following procedure to enable the Wi-Fi radio using Intermec Settings. If you would like to use ScanNGo bar codes to easily enable the radio and set the default security settings, see Appendix C **“ScanNGo Wi-Fi Configuration Bar Codes” on page 165.**

To enable the Wi-Fi radio on your computer and configure communications:

- 1** Tap **Start > Settings > System > Intermec Settings.**
- 2** From the Intermec Settings main menu, tap **Communications > 802.11 Radio > Radio Enabled.**
- 3** Select the **Radio Enabled** check box and tap **OK.** By default, the computer uses Funk security and enables DHCP.
- 4** Use Intermec Settings to configure any other parameters you need to use for communication with your network.
- 5** Configure 802.11 security. For help, see **“About Wireless Security” on page 81.**

Configuring Ethernet Communications

To configure Ethernet communications, connect your mobile computer to your Ethernet network using the Ethernet Snap-On Adapter (Model 1000AA01) or an Ethernet dock.

To configure Ethernet communications:

- 1** Connect the Ethernet snap-on adapter to your mobile computer.
- 2** Connect the Ethernet cable from your network to the snap-on adapter or dock.

Ethernet communications are automatically enabled on your mobile computer.

- 3** Make sure that your computer is communicating with the network. The network connection icon () should appear on the title bar.

Configuring Bluetooth Communications

Your mobile computer is Bluetooth™-enabled, which lets you connect to other Bluetooth devices, such as scanners, printers, or audio devices. You need to turn on the Bluetooth radio before you can discover and connect to other Bluetooth devices. By default, the radio is turned off. To turn on the Bluetooth radio and configure Bluetooth settings:

- 1 Tap **Start > Settings > Bluetooth > Mode**.
- 2 Select the **Turn on Bluetooth** check box.

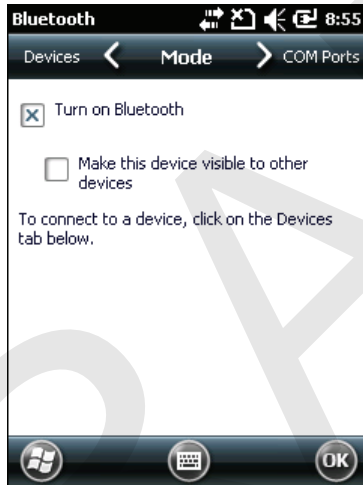

- 3 (Optional) If you want your computer to be visible to other Bluetooth devices, choose **Make this device visible to other devices**.
- 4 Tap **OK**.

The Bluetooth radio maintains its state through a reboot or cold boot and maintains virtual COM ports. But, if you clean boot your computer you need to recreate pairings to devices.

Connecting to a Bluetooth Scanner

You can connect the computer to an Intermec Bluetooth scanner, such as the SF51 or SR61.

To connect to an Intermec Bluetooth scanner:

- 1 Tap **Start > Settings > System > Wireless Scanning.**

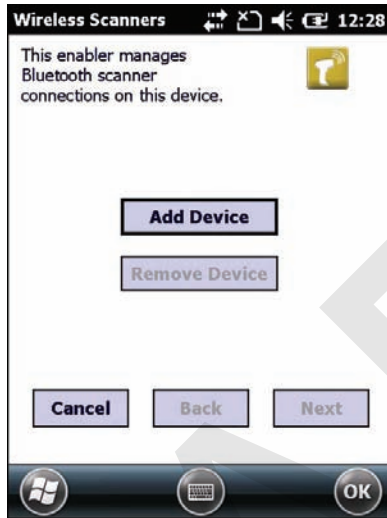

- 2 Tap **Add Device.**

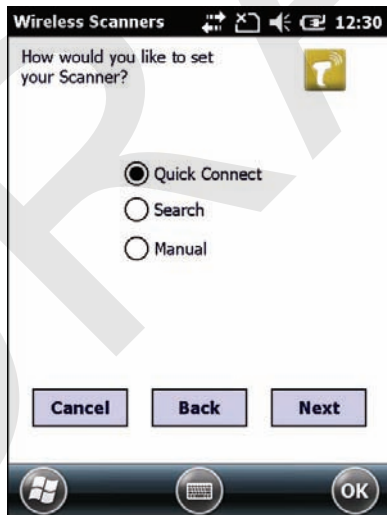

- 3 Select **Quick Connect, Search, or Manual.** Follow the onscreen instruction to add a wireless scanner.

Connecting to a Bluetooth Printer

To configure your computer for Bluetooth wireless printing, you need to:

- create an application that opens the wireless printing COM port on your computer. For help, see the Bluetooth Resource Kit, which is part of the Intermec Developer Library (IDL), available from the Intermec web site at www.intermec.com/idl.
- select the current wireless printer on your computer. For help, see the next procedure.



Note: You can also print wirelessly using Microsoft APIs with Bluetooth extensions for Winsock and Bluetooth virtual COM ports. For help, see the Bluetooth Resource Kit documentation.

To select the current wireless printer:

- 1 Tap **Start > Settings > System > Wireless Printing**.

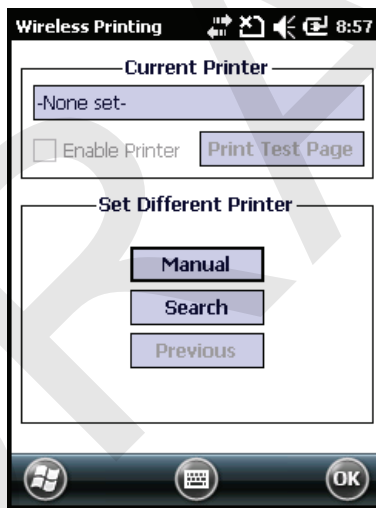

- 2 Tap **Search** to find a printer, or tap **Manual** to enter a device address. Follow the onscreen instructions to select the current wireless printer.
- 3 (Optional) Tap **Print Test Page**. The printer prints out a test page.

Connecting to a Bluetooth Audio Device

Use the Bluetooth Audio enabler to discover, activate, and connect to Bluetooth audio devices such as a headset. This enables system sounds to be monitored through the headset.

To connect to a Bluetooth audio device:

- 1 Tap **Start > Settings > System > Bluetooth Audio**.

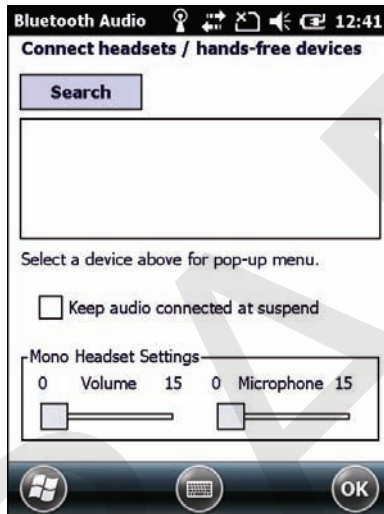

- 2 Tap **Search** to find your Bluetooth headset or hands-free device.
- 3 Select your device from the list and configure any settings.
- 4 Click **OK** when you are done.

About Serial and USB Communications

You can use these 70 Series accessories to transmit data to and receive data from another device through serial or USB communications:

- RS-232 Snap-On Adapter (Model 1000AA03)
- USB Snap-On Adapter (Model 1000AA07)

For more information about these accessories and how to order them, see [“70 Series Accessories” on page 8](#).

Connecting to a Tethered Scanner

Use this procedure to connect your mobile computer to an SR30, SR61T, or ASCII tethered scanner and enable RS-232 communications.

To connect the computer to a tethered scanner:

1 Tap **Start > Settings > System > Intermec Settings > Communications > Serial Port Switch**.

2 Select **Standard docking and IrDA** and tap **OK**.

If the serial port switch is set to one of the other options, you need to select **Standard docking and IrDA** and then save and reboot the computer before you proceed.

3 Tap **Back** to return to the Main Menu.

4 Tap **Data Collection > Dock Tethered Scanner > Enable scanner auto-detect**.

5 Select the **Enable scanner auto-detect** check box and tap **OK**.

6 Perform one of these items based on the type of scanner you are connecting:

- For an SR30 or SR61T scanner, tap **Scanner Settings**, select **SR Intermec Scanner**, and then tap **OK**.
- For an ASCII scanner, tap **Scanner Settings**, select **ASCII**, and then tap **OK**. Set up the appropriate COM port settings by selecting **Scanner Port Settings**.

7 Connect the RS-232 snap-on adapter with the attached scanner to the bottom of the mobile computer.

Creating an ISP Connection

You can create an Internet Service Provider (ISP) connection to send and receive e-mail messages using Messaging (Outlook E-mail) and view web pages using Internet Explorer Mobile. You need to get your ISP dial-up access telephone number, a user name, and a password from your ISP.

To create an ISP Connection:

- 1 Tap **Start** > **Settings** > **Connections** > **Connections**.
- 2 Under **My ISP**, tap **Add a new modem connection**.
- 3 Enter a name for the connection, such as “ISP Connection.”
- 4 If you are using an external modem connected to your mobile computer with a cable, select **Hayes Compatible on COM1** from the **Select a modem** list.
- 5 Tap **Next**.
- 6 Enter the access phone number and then tap **Next**.
- 7 Enter the **User name**, **Password**, and **Domain** (if provided by an ISP or your network administrator).
- 8 Tap **Finish**.
- 9 On the Connections screen, tap **Advanced** on the horizontal scroll.

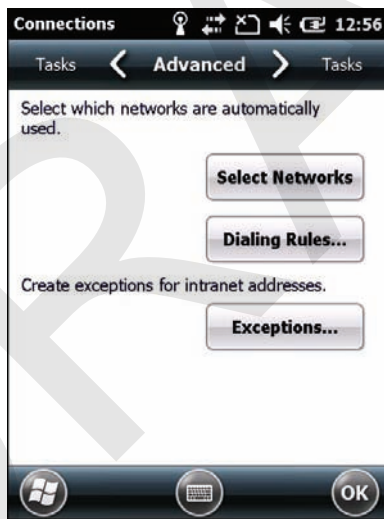

- 10 Tap **Dialing Rules**.
- 11 When the Enable Dialing Rules box appears, tap **OK**.
- 12 Tap **Edit**.

- 13 In the **Name** field, enter your phone type (**Home**, **Mobile**, or **Work**).
- 14 Tap **OK** until you exit the Connections screen.

Creating a VPN Server Connection

You can create a Virtual Private Network (VPN) connection to securely connect to servers, such as a corporate network, through the Internet. Before you can create a VPN connection, you need this information from your network administrator:

- User name
- Password
- Domain name
- TCP/IP settings
- Host name or IP address of the VPN server

To create a VPN server connection:

- 1 Tap **Start > Settings > Connections > Connections**.
- 2 Under **My Work Network**, tap **Add a new VPN server connection**.
- 3 Step through the screens to set up your VPN connection.

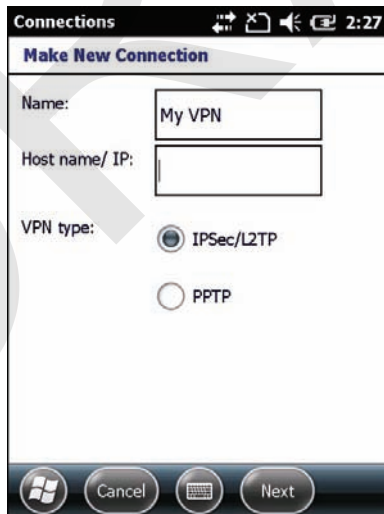

About Wireless Security

The computer provides four types of security for your wireless network:

- Wi-Fi Protected Access 2 (WPA2™)
- Wi-Fi Protected Access (WPA)
- 802.1x
- WEP

This section explains how to configure wireless security on your mobile computer. Intermec recommends that you implement WPA2 security using PSK (Personal) or 802.1X (Enterprise) key management as appropriate.

You must use either Funk or Microsoft security to implement your security solution. For details, see the next section, **“Choosing Between Microsoft and Funk Security.”**

If you are using WPA-802.1x, WPA2-802.1x, or 802.1x security, this section also assumes that your authentication server and authenticators are properly configured.



Note: Your security choice does not depend on your authentication server. For example, you can choose Funk security if you use Microsoft Active Directory® to issue certificates.

Choosing Between Microsoft and Funk Security

The computer supports both Funk and Microsoft security, which dynamically select wireless networks based on your preferences. The option you choose depends on your network security needs.

- If you are using the computer in a static environment that requires a high level of security, you should use Funk security, which offers CCX v4.0 compliance, support for LEAP and TTLS, and configuration for up to four profiles.

To use Funk security, you need to select a profile. For help, see the next section, **“Selecting a Funk Security Profile.”**

- If you are primarily using the computer to connect to Wi-Fi hotspots, you may want to use Microsoft security. To use Microsoft security, you need to select it as your security choice. For help, see “[Selecting Microsoft as Your Security Choice](#)” on page 86.

Selecting a Funk Security Profile

You can define up to four profiles for Funk security. Different profiles let your computer communicate in different networks without having to change all of your security settings. For example, you may want to set up one profile for the manufacturing floor and one for the warehouse. By default, the active profile is Profile 1.

Selecting a Funk Security Profile

Use the following procedure to select a Funk security profile.

- 1 Start Intermec Settings.
- 2 Choose **Communications > 802.11 Radio > Funk Security**.
- 3 Choose a profile. A list of configurable settings appears.
- 4 (Optional) In the **Profile Label** text box, enter a meaningful name for your profile.
- 5 Configure your security settings. For help, see the next sections.
- 6 Repeat Steps 3 through 5 for each profile you want to define.
- 7 Set an active profile by choosing it in the **Active Profile** list.
- 8 Save your settings.

Configuring WPA or WPA2 Enterprise (802.1x) Security With Funk

Use these procedures to set WPA-802.1x or WPA2-802.1x security on your computer with Funk security.

- 1 Make sure the communications and radio parameters on your 70 Series are configured.
- 2 Make sure Funk is selected as your security choice.
- 3 Start Intermec Settings.

- 4 Choose **Communications** > **802.11 Radio** > **Funk Security**.
- 5 Select the profile you want to configure.
- 6 For **Association**, choose **WPA** or **WPA2**. Encryption automatically defaults to **TKIP** or **AES**, respectively.
- 7 For **8021x**, choose **TTLS**, **PEAP**, **EAP-FAST**, or **TLS**.
- 8 If you choose **TTLS**, **EAP-FAST**, or **PEAP**:
 - a For **Prompt for Credentials**, choose **Enter credentials now**.
 - b Enter a **User Name** and **User Password**.
 - c For **Validate Server Certificate**, choose **Yes**.



Note: The correct date must be set on your computer when you enable **Validate Server Certificate**.

- 9 If you choose **TLS**:
 - a Load a user and root certificate on your computer. For help, see **“Loading a Certificate” on page 90**.
 - b Enter a **User Name** and **Subject Name**.
 - c For **Validate Server Certificate**, choose **Yes**.

Configuring WPA or WPA2 Personal (PSK) Security With Funk

Use the following procedure to configure WPA-PSK or WPA2-PSK with Funk security.

- 1 Make sure the communications and radio parameters on your computer are configured.
- 2 Make sure Funk is selected as your security choice.
- 3 Start Intermec Settings.
- 4 Choose **Communications** > **802.11 Radio** > **Funk Security**.
- 5 Select the profile you want to configure.
- 6 For **Association**, choose **WPA** or **WPA2**.
- 7 For **8021x**, choose **None**.

- 8** For **Pre-Shared Key**, enter the pre-shared key or passphrase.

The pre-shared key must be a value of 32 hex pairs preceded by 0x for a total of 66 characters. The value must match the key value on the access point. The passphrase must be from 8 to 63 characters. After you enter a passphrase, the 70 Series internally converts it to a pre-shared key. This value must match the passphrase on the authenticator.

- 9** Save your settings.

Configuring 802.1x Security With Funk Security

Use the following procedure to configure 802.1x-WEP security with Funk security. Intermec recommends that you use WPA2-802.1x instead of 802.1x-WEP if possible.

- 1** Make sure the communications and radio parameters on your computer are configured.
- 2** Make sure Funk is selected as your security choice.
- 3** Start Intermec Settings.
- 4** Choose **Communications > 802.11 Radio > Funk Security**.
- 5** Select the profile you want to configure.
- 6** For **Association**, choose **Open**.
- 7** For Encryption, choose **WEP**.
- 8** For **8021x**, choose **TTLS**, **PEAP**, or **TLS**.
- 9** If you chose **TTLS** or **PEAP**:
 - a** Enter a **User Name**.
 - b** For **Prompt for Credentials**, choose **Enter credentials now**.
 - c** Enter a **User Password**.
 - d** For **Validate Server Certificate**, choose **Yes**.
- 10** If you choose **TLS**:
 - a** Load a user and root certificate on your computer. For help, see **“Loading a Certificate” on page 90**.
 - b** For **Validate Server Certificate**, choose **Yes**.

- c Enter a **User Name** and **Subject Name**.

- 11 Save your settings.

Configuring Static WEP Security With Funk Security

Use the following procedure to configure static WEP security with Funk. Intermec recommends that you use WPA2-PSK instead of WEP if possible.

- 1 Make sure the communications and radio parameters on your computer are configured.
- 2 Make sure Funk is selected as your security choice.
- 3 Start Intermec Settings.
- 4 Choose **Communications** > **802.11 Radio** > **Funk Security**.
- 5 Select the profile you want to configure.
- 6 For **Association**, choose **Open**.
- 7 For **Encryption**, choose **WEP**.
- 8 For **8021x** choose **None**.
- 9 Define a value for the keys you want to use. You can define up to four keys (**Key 1** through **Key 4**).

Enter an ASCII key or a hex key that is either 5 bytes or 13 bytes long depending on the capability of the radio. Set a 5- byte value for 64-bit WEP or a 13-byte value for 128-bit WEP. Hex keys must be preceded by 0x and contain 5 or 13 hex pairs.

- 10 For **Transmit key**, choose the key you want to use for transmitting data.
- 11 Save your settings.

Using Open (No Security) Associations with Funk

Use the following procedure to configure your mobile computer for open security using Funk.

- 1 Start Intermec Settings.
- 2 Choose **Communications** > **802.11 Radio** > **Funk Security**.
- 3 Select the active profile you are using.

- 4** For **Association**, choose **Open**.
- 5** For **Encryption**, choose **None**.
- 6** Tap **OK**. Your settings are saved.

Selecting Microsoft as Your Security Choice

The default security setting is Funk. If you want to use Microsoft Wireless Zero Configuration (WZC) security, you need to select it as your security choice. After you select Microsoft as your security choice, you will be prompted to save your settings and reset the computer for your change to take effect.

With Microsoft as your security choice, you can configure:

- WPA or WPA2
- 802.1x
- Static WEP

Selecting Microsoft Security

Use the following procedure to select Microsoft security.

- 1** Start Intermec Settings. For help, see **“Configuring the Computer” on page 63**.
- 2** Choose **Communications > 802.11 Radio > Security Choice**.
- 3** From the **Security Choice list**, select **Microsoft Security**. An alert box appears telling you that you must save your settings and reboot the computer for the new security choice to take effect.
- 4** Choose **Yes**. The computer resets and starts with Microsoft Security as the Security Choice.

Configuring WPA or WPA2 Enterprise (802.1x) Security With Microsoft

Use these procedures to set WPA-802.1x security on your computer with Microsoft security.

- 1** Make sure the communications and radio parameters on your computer are configured.
- 2** Start Intermec Settings.

- 3 Choose **Communications > 802.11 Radio > Microsoft Security**.
- 4 For **Infrastructure Mode**, choose **Infrastructure**.
- 5 For **Network Authentication**, choose **WPA** or **WPA2**. Data Encryption automatically defaults to **TKIP** for WPA and **AES** for WPA2.
- 6 For **802.1x Authentication**, choose either **TLS**, or **PEAP**.
- 7 If you choose **TLS**:
 - a Load a user and root certificate on your computer. For help, see **“Loading a Certificate” on page 90**.
 - b Choose **Properties**. The Certificates dialog box appears.
 - c Select the certificate you want to use from the list. The User Logon dialog box appears.
 - d Enter a **User Name** and **Domain** and tap **OK**.
 - e Tap **OK** to exit the Certificates dialog box.
 - f Press **OK** to save the Microsoft Security settings.
- 8 If you choose **PEAP**:
 - a Load a root certificate of the authentication server on your computer. For help, see **“Loading a Certificate” on page 90**.
 - b Press **OK** to save the security settings and the User Logon dialog box appears.
 - c Enter a **User Name**, **Password**, and **Domain**. Select **Save Password** if you want to save the password for future authentication sessions.
 - d Press **OK** to save the Microsoft Security settings.

Enabling WPA or WPA2 Personal (PSK) Security With Microsoft

Use the following procedure to enable WPA-PSK With Microsoft Security.

- 1 Make sure the communications and radio parameters on your computer are configured.
- 2 Start Intermec Settings.

- 3** Choose **Communications > 802.11 Radio > Microsoft Security**.
- 4** For **Infrastructure Mode**, choose **Infrastructure**.
- 5** For **Network Authentication**, choose **WPA-PSK**. Data Encryption automatically defaults to **TKIP** for WPA and **AES** for WPA2.
- 6** For **Pre-Shared Key**, enter the pre-shared key or the passphrase.
The pre-shared key must be a value of 32 hex pairs preceded by 0x for a total of 66 characters. The value must match the key value on the authenticator. The passphrase must be from 8 to 63 characters. After you enter a passphrase, the computer internally converts it to a pre-shared key.
- 7** Save your settings.

Configuring 802.1x Security with Microsoft

Use the following procedure to configure 802.1x security with Microsoft security. Intermec recommends that you use WPA2-802.1x instead of 802.1x-WEP if possible.

- 1** Make sure the communications and radio parameters on your computer are configured.
- 2** Start Intermec Settings.
- 3** Choose **Communications > 802.11 Radio > Microsoft Security**.
- 4** For **Infrastructure Mode**, choose **Infrastructure**.
- 5** For **Network Authentication**, choose **Open**.
- 6** For **Data Encryption**, choose **WEP**.
- 7** For **802.1X Authentication**, choose **TLS** or **PEAP**.
- 8** If you choose TLS:
 - a** Load a user and root certificate on your computer. For help, see **“Loading a Certificate” on page 90**.
 - b** Choose **Properties**. The Certificates dialog box appears.
 - c** Select the certificate you want to use from the list. The User Logon dialog box appears.
 - d** Enter a **User Name** and **Domain** and tap **OK**.

- e Tap **OK** to exit the Certificates dialog box.
 - f Press **OK** to save the Microsoft Security settings.
- 9** If you choose PEAP:
- a Load a root certificate of the authentication server on your computer. For help, see **“Loading a Certificate” on page 90**.
 - b Press **OK** to save the security settings and the User Logon dialog box appears.
 - c Enter a **User Name**, **Password**, and **Domain**. Select **Save Password** if you want to save the password for future authentication sessions.
 - d Press **OK** to save the Microsoft Security settings.
- 10** For **Network Key Setting**, choose **Automatic**.
- 11** Save your settings.

Configuring Static WEP Security With Microsoft

Use the following procedure to configure static WEP security with Microsoft security. Intermec recommends that you use WPA2-PSK instead of WEP if possible.

- 1** Make sure the communications and radio parameters on your computer are configured.
- 2** Start Intermec Settings.
- 3** Choose **Communications > 802.11 Radio > Microsoft Security**.
- 4** For **Network Authentication**, choose **Open**.
- 5** For **Data Encryption**, choose **WEP**.
- 6** For **Network Key Setting**, choose **Enter Key and Index**.
- 7** For **Network Key Value**, enter an ASCII key or a hex key that is either 5 bytes or 13 bytes long depending on the capability of the radio.

Set a 5-byte value for 64-bit WEP or a 13-byte value for 128-bit WEP. Hex keys must be preceded by 0x and contain 5 or 13 hex pairs.

- 8 For **Network Key Index**, select the key you want to use for data transmission.
- 9 Save your settings.

Using Open (No Security) Associations With Microsoft

Use the following procedure to configure your mobile computer for open security using Microsoft WZC.

- 1 Start Intermec Settings.
- 2 Choose **Communications > 802.11 Radio > Microsoft Security**.
- 3 For **Network Authentication**, choose **Open**.
- 4 For **Data Encryption**, choose **Disabled**.
- 5 Tap **OK**. Your settings are saved.

Loading a Certificate

To use transport layer security (TLS) with WPA or 802.1x security, you need a unique client certificate on the computer and a trusted root certificate authority (CA) certificate. Certificates are pieces of cryptographic data that guarantee a public key is associated with a private key. They contain a public key and the entity name that owns the key. Each certificate is issued by a certificate authority.

To import a certificate chain:

- 1 Start Intermec Settings.
- 2 Go to **Start > Settings > System > Intermec Settings**.

- 3 Tap **Communications** > **802.11 Radio** > **Certificates**. The Certificates screen appears.

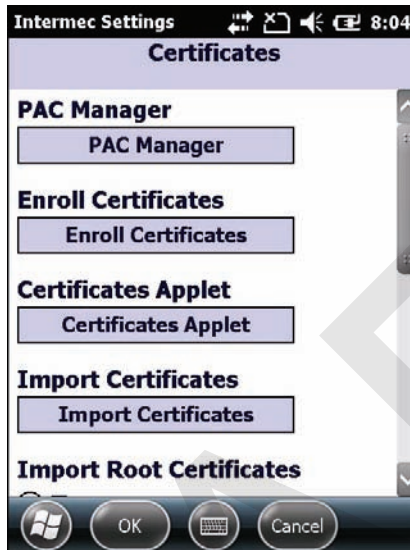

- 4 To import a certificate chain:
 - a Tap **Import Certificates** to install the selected certificate.
 - b In the CertImportUI screen, tap the <<< button next to the Select pfx to import text field.
 - c Select the root certificate from the list.
 - d Tap **Import Certificate**.
- 5 To import user and root certificates from a Microsoft IAS server:
 - a Tap **Import Certificates**.
 - b Tap **Web Enrollment**.
 - c Enter the **User**, **Password**, and **Server** (IP address) to log into the server.
 - d Tap **OK**. A dialog box appears asking if you want to load the root certificate.
 - e Tap **OK**. The Enrollment Tool message box appears telling you that the certificate has been added.
 - f Tap **OK** to close the message box.

DRAFT