



Device Features

- Compliant to Bluetooth specification V1.1
- Small footprint in 8mm x 8mm 81-ball BGA
- Fully integrated RF block with no external adjustments or trim
- USB V1.1 compliant
- Qualified Bluetooth firmware included
- Extensive built-in-self-test to minimise end product final test time
- RF reference designs available
- Low power consumption/optimisation
- Support for up to 7 slaves

General Description

BlueCore™ 01b is a single chip radio and baseband IC for Bluetooth™ 2.4GHz radios, and is implemented in CMOS technology.

When used with external flash containing the CSR Bluetooth software stack, it provides a fully compliant Bluetooth system for data and voice communications.

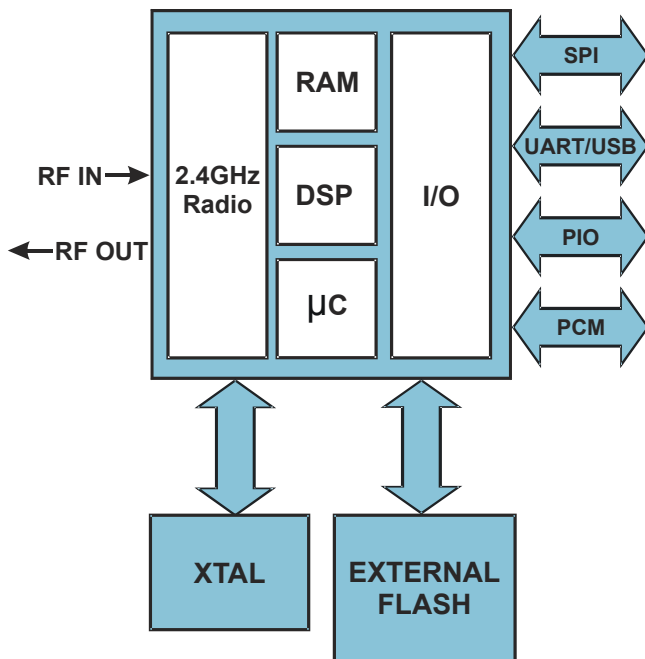

Figure 1: BlueCore01b Block Diagram

BlueCore™ 01b

Single Chip Bluetooth Device

Product Data Sheet For:
BC01b-USB
(USB and UART version)
(BGA Packaging)

BC01b-URT
(UART only version)
(BGA Packaging)

BC01bv-USB
(USB and UART version)
(VFBGA Packaging)

BC01bv-URT
(UART only version)
(VFBGA Packaging)

Applications

- Laptop and Desktop PCs
- Mobile Phones
- Cordless Headsets
- Personal Digital Assistants (PDAs)
- Computer Accessories (Compact Flash, PCMCIA and SD cards)
- Domestic and Industrial Appliances

The design is optimised to require very few external RF components to facilitate rapid design of the application printed wiring board, and therefore the fastest possible time to market and lowest overall cost.

A low intermediate frequency receiver is utilised to allow on-chip channel filtering. All hardware is fully compliant with the Bluetooth specification.

The device operates from a regulated supply in the range 2.7V to 3.3V and is available in an 81-ball BGA package.





Key Features

Radio

- Qualified Bluetooth component
- Extensive built-in-self-test to minimise end product final test time
- No external trimming required in production
- Full RF reference designs available

Transmitter

- Up to 2dBm output power for Class 2 operation
- Support for external PA for Class 1 operation with level control and RSSI >30dB dynamic range

Receiver

- High out-of-band blocking immunity, sufficient for embedding into mobile phones
- Integrated channel filters
- Digital demodulator for superior co-channel rejection

Synthesiser

- Fully integrated; no external VCO varactor diode or resonator
- Closed loop during TX burst resulting in no carrier drift

Baseband

- All packet types supported. Piconet and Scatternet support
- Multiple physical application interfaces:
 - UART:** Data and voice to 1.5Mbs⁻¹
 - PCM:** Programmable, for voice: 13-bit 8kss⁻¹ synchronous bi-directional serial audio interface
 - USB:** Data and voice. V1.1 Compliant. Supports OHCI and UHCI
- Trancoders for A-law, μ -law and CVSD for HCI voice traffic
- Support for up to seven slaves

Firmware

- Link Controller, Link manager and HCI
- Optional build includes embedded L2CAP, RFCOMM and Service Discovery
- Extensive power saving modes, including PARK, HOLD and SNIFF

Ancillary Features

- Internal low-dropout regulator with low stand-by current (uses one external transistor)
- Crystal oscillator with digital trimming allows use of low cost reference crystal
- Power-On-Reset

Device Diagram

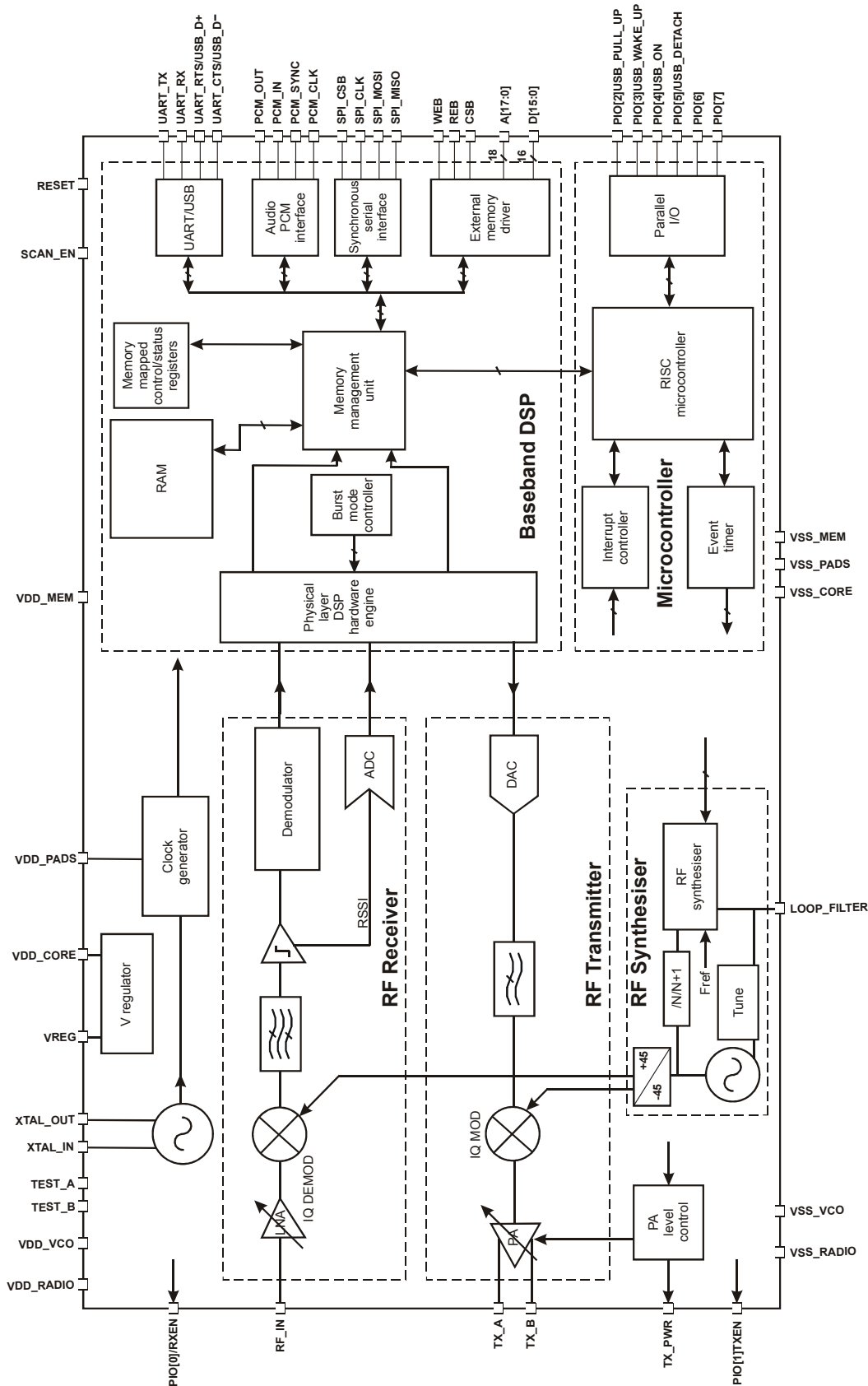

Figure 2: BlueCore01b Device Diagram

Device Pinout Diagram

Orientation from top of device

	1	2	3	4	5	6	7	8	9
A	VSS_PADS	VDD_PADS	UART_TX	UART_RTS / USB_D+	VDD_MEM	VSS_MEM	WEB	A[0]	A[1]
B	PIO[3] / USB_WAKE_UP	PIO[4] / USB_ON	UART_RX	UART_CTS / USB_D-	PCM_SYNC	A[6]	A[3]	A[4]	A[2]
C	RESET	PIO[2] / USB_PULL_UP	SPI_MISO	SPI_MOSI	PCM_IN	D[15]	A[9]	A[7]	A[5]
D	TX_PWR	PIO[0] / RXEN	SPI_CLK	SPI_CSB	PCM_CLK	A[12]	A[11]	A[10]	A[8]
E	RF_IN	VSS_RADIO	PCM_OUT	SCAN_EN	NC (1)	D[13]	A[15]	A[13]	A[14]
F	TX_B	VSS_RADIO	PIO[1] / TXEN	PIO[5] / USB_DETACH	D[11]	D[12]	D[10]	A[17]	CSB
G	TX_A	VDD_RADIO	PIO[6]	PIO[7]	D[14]	D[7]	D[9]	A[16]	REB
H	VSS_VCO	LOOP_FILTER	TEST_B	VDD_CORE	VSS_CORE	D[6]	D[4]	D[3]	D[0]
J	VDD_VCO	TEST_A	XTAL_OUT	XTAL_IN	VREG	D[8]	D[5]	D[2]	D[1]

Note:

(1) = Not connected.

Figure 3: BlueCore01b Device Pinout



Device Terminal Functions

Terminal Name	Pad Type	Ball	Description
Radio			
RF_IN	-	E1	Receiver RF input
TX_A	-	G1	Transmitter RF output
TX_B	-	F1	Transmitter RF output (complement of TX_A)
PIO[0] / RXEN	Bidirectional pulled down	D2	Control output for external switch or LNA (if fitted)
PIO[1] / TXEN	Bidirectional pulled down	F3	Control output for external switch or PA (if fitted)
TX_PWR	Current DAC	D1	Current DAC output to set external PA level
Synthesiser and Oscillator			
XTAL_IN	-	J4	Sense for crystal or external clock input
XTAL_OUT	-	J3	Drive for crystal
LOOP_FILTER	-	H2	Synthesiser external loop filter
External Memory Port			
A[17:0]	CMOS output	(1)	Address bus for external memory
D[15:0]	Bidirectional	(1)	Data bus for external memory
WEB	CMOS output	A7	Write enable for external memory (active low)
REB	CMOS output	G9	Read enable for external memory (active low)
CSB	CMOS output	F9	Chip select for external memory (active low)
PCM Interface			
PCM_SYNC	Bidirectional pulled down	B5	Synchronous data strobe
PCM_CLK	Bidirectional pulled down	D5	Synchronous data clock
PCM_IN	CMOS input pulled down	C5	Synchronous 8kss ⁻¹ data input
PCM_OUT	CMOS output	E3	Synchronous 8kss ⁻¹ data output

Note:

(1) See Address and Data Bus tables at the end of this section.



Terminal Name	Pad Type	Ball	Description
UART or USB⁽¹⁾			
UART_TX	CMOS output	A3	UART data output
UART_RX	CMOS input, 5V tolerant pulled down	B3	UART data input
UART_RTS / USB_D+	CMOS output	A4	UART ready to send / USB D+
UART_CTS / USB_D-	CMOS input	B4	UART clear to send / USB D-
PIO[2] / USB_PULL_UP	Bidirectional pulled down	C2	USB pull-up (via 1.5kΩ resistor to D+)
PIO[3] / USB_WAKE_UP	Bidirectional pulled down	B1	Output goes high to wake up PC when in USB mode
PIO[4] / USB_ON	Bidirectional pulled down	B2	USB on (input senses when VBUS is high, wakes BlueCore01b)
PIO[5] / USB_DETACH	Bidirectional pulled down	F4	Chip detaches from USB when this line is high
Test and Debug			
SPI_CSB	CMOS input, 5V tolerant pulled up	D4	SPI chip select
SPI_CLK	CMOS input, 5V tolerant pulled down	D3	SPI clock
SPI_MOSI	CMOS input, 5V tolerant pulled down	C4	SPI data input
SPI_MISO	CMOS output Tristate	C3	SPI data output
TEST_A	-	J2	Analog test port A
TEST_B	-	H3	Analog test port B
RESET	CMOS input with weak internal pull-down	C1	Reset
SCAN_EN	CMOS input with weak internal pull-down	E4	For test purposes only (leave unconnected)
PIO Port			
PIO[0] /RXEN	Bidirectional pulled down	D2	Input/Output port or high when RX is enabled
PIO[1] /TXEN	Bidirectional pulled down	F3	Input/Output port or high when TX is enabled
PIO[2] /USB_PULL_UP	Bidirectional pulled down	C2	Input/Output port or USB
PIO[3] /USB_WAKE_UP	Bidirectional pulled down	B1	Input/Output port or USB
PIO[4] /USB_ON	Bidirectional pulled down	B2	Input/Output port or USB
PIO[5] /USB_DETACH	Bidirectional pulled down	F4	Input/Output port or USB
PIO[6]	Bidirectional pulled down	G3	Input/Output port
PIO[7]	Bidirectional pulled down	G4	Input/Output port

Note:

⁽¹⁾ BC01b-USB supports both USB and UART (but not simultaneous operation). BC01b-URT supports UART only.



Terminal Name	Pad Type	Ball	Description
Power Supplies and Control			
VREG	-	J5	LDO voltage regulator output to external pass transistor
VDD_CORE	VDD	H4	For internal digital circuitry
VDD_RADIO	VDD	G2	For RF circuitry
VDD_VCO	VDD	J1	For VCO and synthesiser
VDD_PADS	VDD	A2	For all Input/Output except memory port
VDD_MEM	VDD	A5	For external memory port
VSS_CORE	VSS	H5	For internal digital circuitry
VSS_RADIO	VSS	F2, E2	For RF circuitry
VSS_VCO	VSS	H1	For VCO and synthesiser
VSS_PADS	VSS	A1	For Input/Output except memory port
VSS_MEM	VSS	A6	For external memory port

Address Lines	
Terminal	Ball
A[0]	A8
A[1]	A9
A[2]	B9
A[3]	B7
A[4]	B8
A[5]	C9
A[6]	B6
A[7]	C8
A[8]	D9
A[9]	C7
A[10]	D8
A[11]	D7
A[12]	D6
A[13]	E8
A[14]	E9
A[15]	E7
A[16]	G8
A[17]	F8

Data Bus	
Terminal	Ball
D[0]	H9
D[1]	J9
D[2]	J8
D[3]	H8
D[4]	H7
D[5]	J7
D[6]	H6
D[7]	G6
D[8]	J6
D[9]	G7
D[10]	F7
D[11]	F5
D[12]	F6
D[13]	E6
D[14]	G5
D[15]	C6



Electrical Characteristics

Absolute Maximum Ratings		
Rating	Min	Max
Storage Temperature	-30°C	85°C
Supply Voltage, VDD	-0.4V	3.6V
Other Terminal Voltages (except 5V tolerant)	VSS-0.4V	VDD+0.4V
5V Tolerant Terminals	-0.4V	5.5V

Recommended Operating Conditions		
Operating Condition	Min	Max
Temperature	-20°C ⁽¹⁾	70°C ⁽¹⁾
Supply Voltage, all VDD terminals	2.7V	3.3V ⁽²⁾
Supply Voltage, VDD_PADS for USB operation	3.0V	3.4V
Difference between any two VDD terminals	-	0.3V

Notes:

- ⁽¹⁾ The device is fully functional across this range.
The guaranteed radio performance is shown in the Radio Characteristics section.
- ⁽²⁾ The recommended supply voltage is 3.3V (to be compatible with industry standard regulators) but the device will function up to 3.4V.

Input/Output Terminal Characteristics

VDD = 3.0V (except as specified)

Digital Terminals	Min	Typ	Max	Unit
Input voltage				
V _L input logic level low	-0.4	-	0.3V x VDD	V
V _H input logic level high	0.7VDD	-	VDD+0.4	V
Input current				
CMOS input only (V _I = 0V or V _I = 3.3V, VDD = 3.3V)	-1	-	1	μA
CMOS input + pull-up (V _I = 0V, VDD = 3.3V)	-20	-	-125	μA
CMOS input + pull-down (V _I = 3.3V, VDD = 3.3V)	20/2 ⁽¹⁾	-	125/12.5 ⁽¹⁾	μA
Output voltage				
V _{OL} output logic level low (I _O = 4.0mA)	-	-	0.2	V
V _{OH} output logic level high (I _O = -4.0mA)	VDD-0.2	-	-	V
Tristate leakage current	-1	-	1	μA
C _I Input capacitance	2.5	-	10	pF

Note:

- ⁽¹⁾ PIO terminals have weak pull-down resistors (1/10th current of standard pull-down resistors).



Input/Output Terminal Characteristics (continued)				
Power-on Reset	Min	Typ	Max	Unit
VDD falling threshold	2.30	2.40	2.50	V
VDD rising threshold	2.50	2.60	2.70	V
Hysteresis	180	200	220	mV
USB Terminals	Min	Typ	Max	Unit
Input threshold				
V _{IL} input logic level low	-	-	0.3VDD_PADS	V
V _{IH} input logic level high	0.7VDD_PADS	-	-	V
Input leakage current	-1	-	1	μA
C _I Input capacitance	2.5	-	10	pF
Output levels to correctly terminated USB cable				
V _{OL} input logic level low	0	-	0.2	V
V _{OH} input logic level high	2.8	-	VDD_PADS	V
Voltage Regulator (VREG)	Min	Typ	Max	Unit
Output regulation voltage ⁽¹⁾	2.74	2.79	2.84	V
	3.1	3.15	3.2	V
Maximum allowable voltage on V _{reg} pad	-	-	5	V
Bias current	5	-	-	μA
Maximum regulation current	-	-	100	mA

Note:

⁽¹⁾ The regulated voltage is selected by a variable stored in the flash ROM.

Power Consumption⁽¹⁾

VDD = 3.0V Temperature = 20°C

Mode	Avg	Peak	Unit
SCO connection HV3 (1s interval sniff mode) (Slave)	41	-	mA
SCO connection HV3 (1s interval sniff mode) (Master)	42	-	mA
SCO connection HV1 (Slave)	78	-	mA
SCO connection HV1 (Master)	77	-	mA
ACL data transfer 115.2kbps UART (Master)	29	-	mA
ACL data transfer 720kbps USB (Slave)	81	-	mA
ACL data transfer 720kbps USB (Master)	82	-	mA
Peak current during RF burst	-	135	mA
ACL connection, Sniff Mode 40ms interval, 38.4kbps UART	5.5	-	mA
ACL connection, Sniff Mode 1.28s interval, 38.4kbps UART	1.1	-	mA
Parked Slave, 1.28s beacon interval, 38.4kbps UART	1.1	-	mA
Deep Sleep Mode	90		μA

Note:

⁽¹⁾ Power consumption is for BC01b-USB module including external flash ROM.



Radio Characteristics at 20°C

VDD = 3.0V f=2.45GHz

Receiver	Min	Typ	Max	Bluetooth Specification	Unit
Sensitivity at 0.1% BER ⁽¹⁾	-	-79	-75	≤-70	dBm
Sensitivity at 0.1% BER ⁽¹⁾ with additional off-chip LNA	-	-89	-	≤-70	dBm
Maximum received signal ⁽¹⁾	-	-5	-	≥-20	dBm
C/I co-channel ⁽¹⁾	-	9	-	≤11	dB
Adjacent channel selectivity C/I 1MHz ⁽¹⁾	-	-2	-	≤0	dB
2nd adjacent channel selectivity C/I 2MHz ⁽¹⁾	-	-34	-	≤-30	dB
3rd adjacent channel selectivity C/I >3MHz ^{(1) (2)}	-	-45	-	≤-40	dB
Image rejection C/I ^{(1) (3)}	-	-14	-	≤-9	dB
Maximum level of intermodulation interferers ^{(1) (4)}	-	-30	-	≤-39	dBm
1dB compression point at 1.9GHz	-	-12	-	-	dBm
Transmitter	Min	Typ	Max	Bluetooth Specification	Unit
RF transmit power ⁽¹⁾	-2	2	6	-6 to +4	dBm
RF power control range ⁽¹⁾	-	30	-	≥16	dB
RF power range control resolution	-	2	-	-	dB
20dB bandwidth for modulated carrier	-	885	-	≤1000	kHz
2nd adjacent channel transmit power ⁽¹⁾	-	-47	-	≤-20	dBc
3rd adjacent channel transmit power ⁽¹⁾	-	-52	-	≤-40	dBc

Radio Characteristics at 50°C

VDD = 3.0V f=2.45GHz

Receiver	Min	Typ	Max	Bluetooth Specification	Unit
Sensitivity at 0.1% BER ⁽¹⁾	-	-74	-70	≤-70	dBm
Sensitivity at 0.1% BER ⁽¹⁾ with additional off-chip LNA	-	-88	-	≤-70	dBm
Transmitter	Min	Typ	Max	Bluetooth Specification	Unit
RF transmit power ⁽¹⁾	-5	-1	3	-6 to +4	dBm

Notes:

- ⁽¹⁾ Measured according to the Bluetooth specification.
- ⁽²⁾ Up to five spurious responses within Bluetooth limits are allowed.
- ⁽³⁾ At carrier -3MHz.
- ⁽⁴⁾ Measured at f₁-f₂=5MHz.

These results were measured on the BlueCore01b chip. Results shown relate to power at the output of the balun and at the input to the RX matching network. The loss of the RF filter and switch in the application circuit are not taken into account.

BlueCore01b meets the Bluetooth specification when used in a suitable application circuit between -20°C and 50°C. When used with an off-chip LNA the sensitivity can be enhanced and the operating temperature range extended.

Package Dimensions

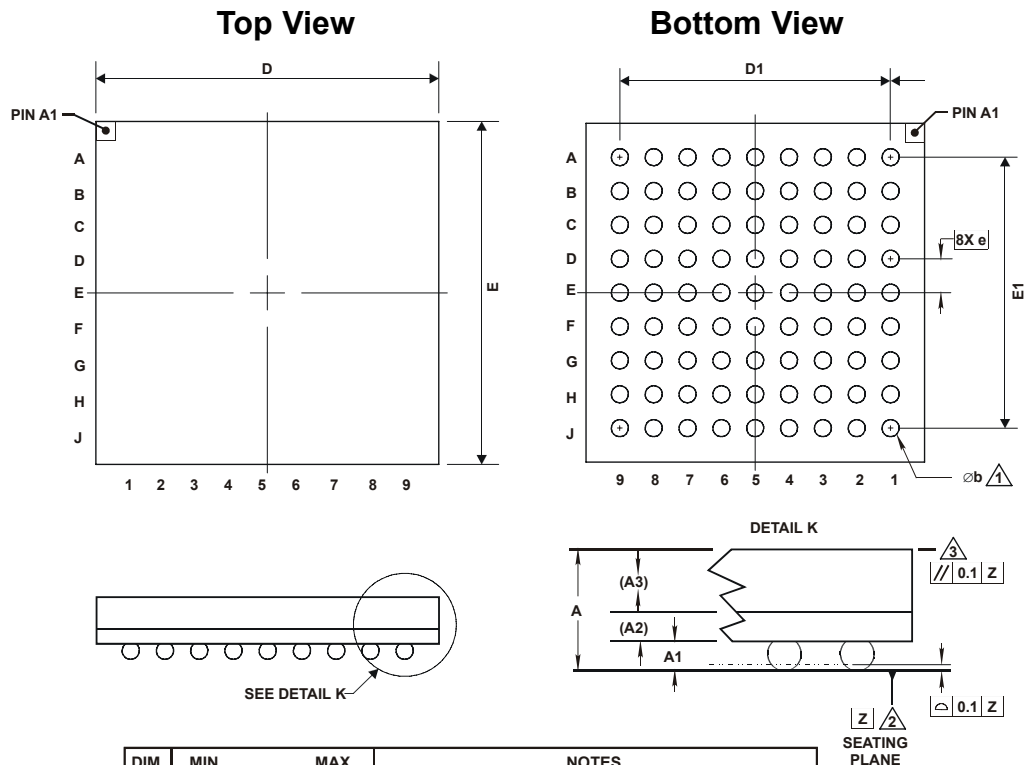

DIM	MIN	MAX	NOTES	
A	1.1	1.50	⚠ DIMENSION b IS MEASURED AT THE MAXIMUM SOLDER BALL DIAMETER PARALLEL TO DATUM PLANE Z.	
A1	0.25	0.35		
A2		0.36 REF	⚠ DATUM Z IS DEFINED BY THE SPHERICAL CROWNS OF THE SOLDER BALLS.	
A3		0.8 REF		
b	0.35	0.45	⚠ PARALLELISM MEASUREMENT SHALL EXCLUDE ANY EFFECT OF MARK ON TOP SURFACE OF PACKAGE.	
D		8 BSC		
E		8 BSC		
e		0.8 BSC		
D1		6.4 BSC		
E1		6.4 BSC		
BC01b-USB/URT BGA 81 BALLS 8X8X1 PKG PITCH POD (JEDEC MO-205)				UNIT MM

DIM	MIN	MAX	NOTES	
A	0.8	1	⚠ DIMENSION b IS MEASURED AT THE MAXIMUM SOLDER BALL DIAMETER PARALLEL TO DATUM PLANE Z.	
A1	0.25	0.35		
A2		0.22 REF	⚠ DATUM Z IS DEFINED BY THE SPHERICAL CROWNS OF THE SOLDER BALLS.	
A3		0.45 REF		
b	0.35	0.45	⚠ PARALLELISM MEASUREMENT SHALL EXCLUDE ANY EFFECT OF MARK ON TOP SURFACE OF PACKAGE.	
D		8 BSC		
E		8 BSC		
e		0.8 BSC		
D1		6.4 BSC		
E1		6.4 BSC		
BC01bv-USB/URT VFPGA 81 BALLS 8X8X1 PKG PITCH POD (JEDEC MO-225)				UNIT MM

Figure 4: BlueCore01b package dimensions

Assembly Guidelines

Figures 5 and 6 show the re-flow solder profile that was used to qualify the BlueCore01b packages.

This temperature profile was repeated three times during the qualification of the BlueCore01b packages with a maximum temperature of 235°C.

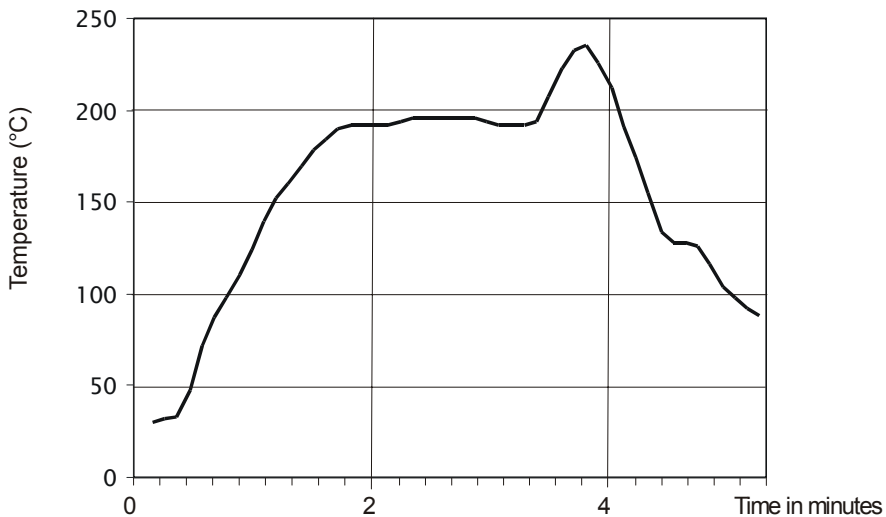

Figure 5: Re-flow solder profile 1

Whereas the above profile was used to confirm the reliability of the BlueCore01b packages, the following (figure 6) is the recommended solder profile to be used when assembling BlueCore01b onto a circuit board.

Recommended Re-flow Solder Profile

The recommended re-flow solder profile is shown in figure 6.

Important points to note are:

- Maximum peak temperature should not exceed 220°C.
- Time above liquidus should be between 45 to 90 seconds.
- Rapid quenching provides superior cosmetic appearance and bond strength.

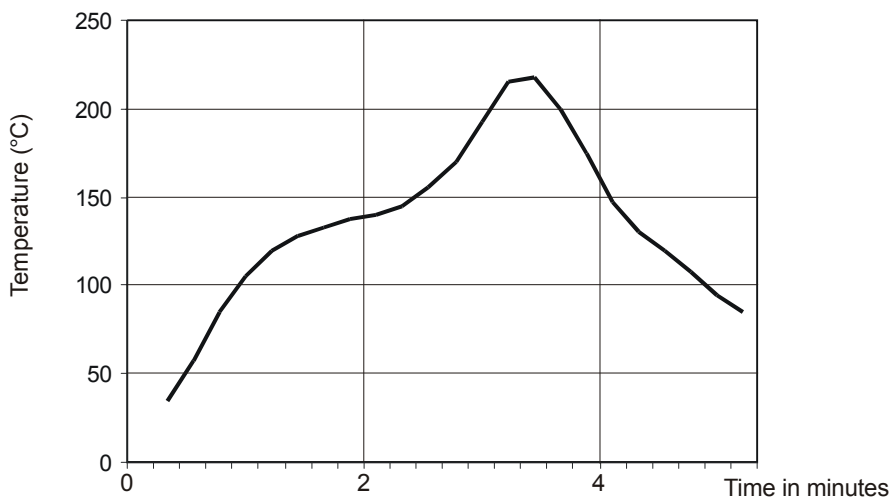

Figure 6: Re-flow solder profile 2



Ordering and Contact Information

Order Number	Interface Version	Shipment Method
BC01b-USB-TR	USB and UART	Tape and reel
BC01b-USB	USB and UART	Tray (dry pack)
BC01b-URT-TR	UART only	Tape and reel
BC01b-URT	UART only	Tray (dry pack)
BC01bv-USB-TR	USB and UART	Tape and reel
BC01bv-USB	USB and UART	Tray (dry pack)
BC01bv-URT-TR	UART only	Tape and reel
BC01bv-URT	UART only	Tray (dry pack)

Contact CSR Worldwide



CSR USA
 1651 N. Collins Blvd.
 Suite 210
 Richardson
 TX75080
 USA
 Tel: +1 972 238 2300
 Fax: +1 972 231 1440
 e-mail: sales@csr.com

CSR Head Office
 Cambridge Science Park
 Milton Road
 Cambridge, CB4 0WH
 United Kingdom
 Tel: +44 (0) 1223 692 000
 Fax: +44 (0) 1223 692 001
 e-mail: sales@csr.com

CSR Japan
CSR KK
 Miyasaka LK Building 3F
 43-23, 3 Chome Shimorenjaku
 Mitaka-shi, Tokyo
 Japan 181-0013
 Tel: +81 (0) 422 40 4760
 Fax: +81 (0) 422 40 4765
 e-mail: sales@csr.com

CSR Singapore
 Blk 5, Ang Mo Kio
 Industrial Park 2A
 AMK Tech II, #07-08
 Singapore 567760
 Tel: +65 484 2212
 Fax: +65 484 2219
 e-mail: sales@csr.com

CSR Denmark
 Novi Science Park
 Niels Jernes Vej 10
 9220 Aalborg East
 Denmark
 Tel: +45 72 200 380
 Fax: +45 96 354 599
 e-mail: sales@csr.com

To contact a CSR representative, please go to www.csr.com/contacts.htm



Status of Information

The progression of CSR Product Data Sheets follows the following format:

a) Advance Information

Information for designers on the target specification for a CSR product in development. All detailed specifications including pinouts and electrical specifications may be changed by CSR without notice.

b) Pre-Production Information

Final pinout and mechanical dimensions. All electrical specifications may be changed by CSR without notice.

c) Production Information

Final Data Sheet including the guaranteed minimum and maximum limits for the electrical specifications. Production Data Sheets supersede all previous document versions.

The status of this Data Sheet is **Production Information**.

The long form version of this Data Sheet is available separately from CSR.

Life Support Policy and Use in Safety-Critical Applications

CSR's products are not authorised for use in life-support or safety-critical applications.

Trademarks, Patents and Licenses

BlueCore is a trademark of CSR.

Bluetooth and the Bluetooth logos are trademarks owned by Bluetooth SIG Inc, USA and licensed to CSR. All other product, service, and company names are trademarks, registered trademarks, or service marks of their respective owners.

The publication of this information does not imply that any license is granted under any patent or other rights owned by CSR.

CSR reserves the right to make technical changes to its products as part of its development programme.

While every care has been taken to ensure the accuracy of the contents of this document, CSR cannot accept responsibility for any errors.

©CSR Ltd 2001



Record of Changes

Date:	Revision:	Reason for Change:
21st Feburary 2001	bc01b-ds-003a	Input/Output terminal characteristics information updated
23rd March 2001	bc01b-ds-003b	Minor modifications to RF characteristics based upon latest characterisation data
6th July 2001	bc01b-ds-003c	System features added and power consumption figures expanded
26th July 2001	bc01b-ds-003d	Package dimensions added for VFBGA packaging

BlueCore01b Product Data Sheet

bc01b-ds-003d

July 2001