

PB22&PB32

Portable Label and Receipt Printer

**User's
Guide**

Intermec®

Intermec Technologies Corporation

Worldwide Headquarters

6001 36th Ave.W.

Everett, WA 98203

U.S.A.

www.intermec.com

The information contained herein is provided solely for the purpose of allowing customers to operate and service Intermec-manufactured equipment and is not to be released, reproduced, or used for any other purpose without written permission of Intermec Technologies Corporation.

Information and specifications contained in this document are subject to change without prior notice and do not represent a commitment on the part of Intermec Technologies Corporation.

© 2009 by Intermec Technologies Corporation. All rights reserved.

The word Intermec, the Intermec logo, Norand, ArciTech, Beverage Routebook, CrossBar, dcBrowser, Duratherm, EasyADC, EasyCoder, EasySet, Fingerprint, i-gistics, INCA (under license), Intellitag, Intellitag Gen2, JANUS, LabelShop, MobileLAN, Picolink, Ready-to-Work, RoutePower, Sabre, ScanPlus, ShopScan, Smart Mobile Computing, SmartSystems, TE 2000, Trakker Antares, and Vista Powered are either trademarks or registered trademarks of Intermec Technologies Corporation.

There are U.S. and foreign patents as well as U.S. and foreign patents pending.

Wi-Fi is a registered certification mark of the Wi-Fi Alliance.

Bluetooth is a trademark of Bluetooth SIG, Inc., U.S.A.

Before You Begin

Before You Begin

This section provides you with safety information, technical support information, and sources for additional product information.

Safety Information

Your safety is extremely important. Read and follow all warnings and cautions in this document before handling and operating Intermec equipment. You can be seriously injured, and equipment and data can be damaged if you do not follow the safety warnings and cautions.

This section explains how to identify and understand warnings, cautions, and notes that are used in this document.



A warning alerts you of an operating procedure, practice, condition, or statement that must be strictly observed to avoid death or serious injury to the persons working on the equipment.



A caution alerts you to an operating procedure, practice, condition, or statement that must be strictly observed to prevent equipment damage or destruction, or corruption or loss of data.



Note: Notes either provide extra information about a topic or contain special instructions for handling a particular condition or set of circumstances.

Global Services and Support

Warranty Information

To understand the warranty for your Intermec product, visit the Intermec web site at www.intermec.com and click **Support > Returns and Repairs > Warranty**.

Web Support

Visit the Intermec web site at www.intermec.com to download our current manuals (in PDF). To order printed versions of the Intermec manuals, contact your local Intermec representative or distributor.

Visit the Intermec technical knowledge base (Knowledge Central) at intermec.custhelp.com to review technical information or to request technical support for your Intermec product.

Telephone Support

In the U.S.A. and Canada, call **1-800-755-5505**.

Outside the U.S.A. and Canada, contact your local Intermec representative. To search for your local representative, from the Intermec web site, click **About Us > Contact Us**.

Service Location Support

For technical support in South Korea, use the after service locations listed below:

AWOO Systems

102-1304 SK Ventium
522 Dangjung-dong
Gunpo-si, Gyeonggi-do Korea, South 435-776
Contact: Mr. Sinbum Kang
Telephone: +82-31-436-1191
Email: sbkang@awoo.co.kr

Sammi Information Systems Co Ltd

7-9FL, Seo Jo Building
103-15, Galwor-Dong
Seoul, Yong San-ku Korea, South 140-807
Contact: Kyung-Hee Koo
Telephone: +82-2-790-5508
Email: jlovekoo@sammicomputer.co.kr

Who Should Read This Manual

This user's guide is for the person who is responsible for installing, configuring, and maintaining the PB22/PB32 printer.

Before You Begin

This guide provides you with information about the features of the PB22/PB32, and how to install, configure, operate, maintain, and troubleshoot it.

Before you work with the PB22/PB32, you should be familiar with your network and general networking terms, such as IP address.

Related Documents

This table contains a list of related Intermec documents and their part numbers.

Document Title	Part Number
<i>Intermec Fingerprint Programmer's Reference Manual</i>	937-005-xxx
<i>Intermec Printer Language (IPL) Developer's Guide</i>	934-013-xxx
<i>Intermec Printer Language (IPL) Command Reference Manual</i>	937-007-xxx
<i>ESC/P Programmer's Reference Manual.</i>	937-010-xxx

The Intermec web site at www.intermec.com contains our documents (as PDF files) that you can download for free.

To download documents

- 1 Visit the Intermec web site at www.intermec.com.
- 2 Click **Support > Manuals**.
- 3 Use the **Product Category** field, the **Product Family** field, and the **Product** field to help you locate the product whose documentation you want to download.

1

Using the PB22/PB32 Portable Label and Receipt Printer

Use this chapter to familiarize yourself with the PB22/PB32 Portable Label and Receipt Printer. In this chapter you will find these sections:

- **Learning About the PB22/PB32 Mobile Label Printer**
- **Using the Batteries**
- **Loading Media**
- **Printing a Test Page**

Learning About the PB22/PB32 Mobile Label and Receipt Printer

The PB22/PB32 is a rugged direct thermal label and receipt printer that is designed for use with the CK3x, 700 series, CK6x, CN3, CN3e, CK3, CV30, and CV60 mobile computers as well as the SF51 and SR61 scanners. The PB22 uses 50.8 mm (2 in) media and the PB32 uses 76.2 mm (3 in) media.

The PB22/PB32 provides:

- print resolution of 203 dpi.
- print speeds of up to 100 mm per second (4 ips).
- 802.11 or Bluetooth radio options.

Identifying the Parts of the Printer

Use this illustration to familiarize yourself with some of the features of the PB22/PB32.

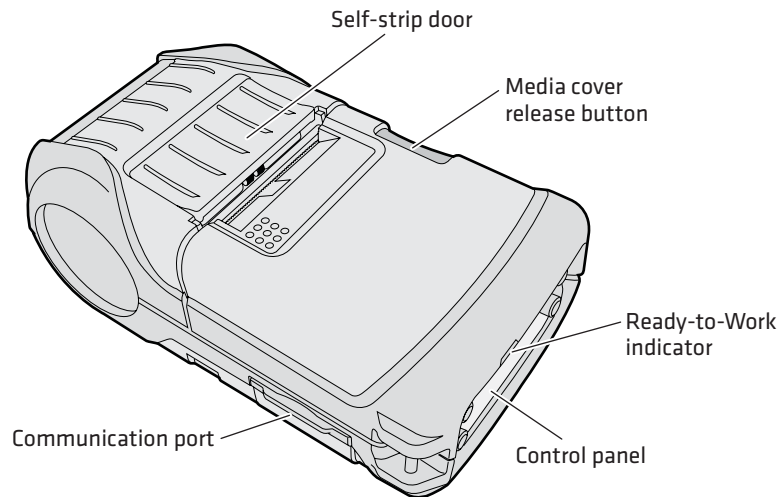



PB22/PB32 Printer: This illustration shows the important features of the PB22/PB32 printer. A weather-resistant flap protects the communications ports and the external power connector.

Understanding the Control Panel

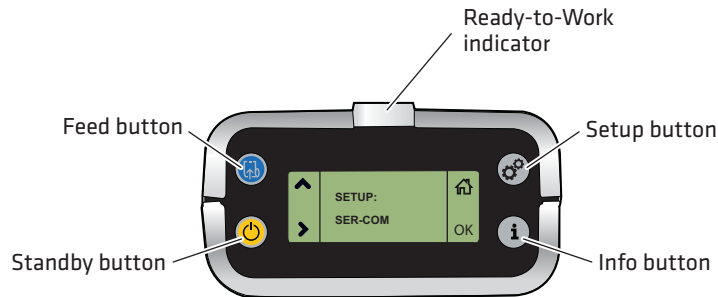
The PB22/PB32 control panel contains four buttons, a liquid crystal display (LCD), and one LED indicator. Use the four buttons to navigate the menu system and perform functions on the PB22/PB32 printer. See the following tables to understand the buttons, the menu system, and what the LED means.



Understanding How to Use the PB22/PB32 Buttons











Button Name	Button	Function
Feed		Press to advance label or receipt paper. The amount of media that feeds is dependent on the type of media you are using. It will advance by 5 mm (0.2 inch), feed out an entire label, or feed a configured length of media based on your media and settings. If the printer is printing, pressing this button causes the printer to pause. Press the button again to resume printing.
Setup		Press to display the Setup menu. Not used with ESC/P firmware.
Standby (Power)		Press to put the printer in Standby mode. In Standby mode, power to the radio, the display, and the backlight are turned off. Press to turn the printer back on and put in Ready mode.

Understanding How to Use the PB22/PB32 Buttons (continued)

Button Name	Button	Function
Info		Press to display a summary of network connection information and error conditions. Each setting in the summary information displays on the screen for five seconds.

All of the buttons can act as “soft keys,” which means that the function of each button depends on the state of the printer. A small icon appears in the screen next to the button to indicate the function it performs.

Understanding the Soft Keys

Button	Soft Keys	Description
		• Moves up one level in the menu system. This soft key appears in Setup mode.
		• Increases the value of a number when editing settings such as an IP address. This soft key appears in Setup mode.
		• Pauses the printing job. This icon appears only when you are printing.
		Exit Setup mode and return to Ready mode.
		Moves through the settings at the same level in the menu system.
	OK	• Moves down one level in the menu system and saves changes to a setting.
		• Exits a printing job or exits Information mode.

Chapter 1 – Using the PB22/PB32 Portable Label and Receipt Printer

There is only one LED on the PB22/PB32 printer: the Ready-to-Work™ indicator.

Understanding the Ready-to-Work Indicator

Indicator State	Description
Off	When the light is off, it can mean one of several conditions: <ul style="list-style-type: none">• The printer is in Standby mode.• The printer is in Info mode.• The printer is in Setup mode.
On	The PB22/PB32 is turned on and operating.
Blinking	A blinking light can mean one of several conditions: <ul style="list-style-type: none">• The printer is out of paper.• The media cover is open.• There is a printer error that requires you to perform an action. For a list of possible problems, see “Troubleshooting the PB22/PB32” on page 42.

Understanding the Printer Firmware

Your PB22/PB32 printer comes with Intermec Printer Language (IPL), Fingerprint, or Intermec Receipt Protocol (ESC/P) firmware. The choice of firmware affects the functionality of the printer and how you interact with it. This manual contains information for using the different types of printer firmware.

When the printer is shipped from the factory, the first person to turn on the printer will have the option of choosing which printer firmware to run on the printer. Press the appropriate button to choose a firmware type.

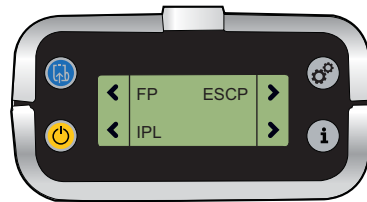

Choosing the Printer Firmware

Chapter 1 – Using the PB22/PB32 Portable Label and Receipt Printer

The current firmware type and version display on the PB22/PB32 screen when the printer is in Ready mode.



The screen of a PB22/PB32 running IPL firmware

Understanding the Printer Sounds

The PB22/PB32 plays sounds in response to several actions that you can take with the printer. Use the following table to understand when the sounds occur and what they mean.

Understanding the Printer Sounds

Sound	Occurs When:
Power	<ul style="list-style-type: none">You insert a battery in the printer.The PB22/PB32 starts charging the battery.You plug in the AC adaptor.
Hardware	You open the media door, close the media door, or insert a cable.
Button	You press any of the PB22/PB32 buttons.
Error	<ul style="list-style-type: none">The printer cannot feed paper or print a job because of a hardware issue such as the media door open, a paper jam, or there is no media.An error occurs such as a paper jam, a print error, or the printer is out of range.

Understanding the Backlight

The screen backlight on the PB22/PB32 behaves the same way as a screensaver on your PC. After a set amount of time elapses without any user interaction, the backlight goes off. The screen backlight turns on when:

- the printer begins printing.

Chapter 1 – Using the PB22/PB32 Portable Label and Receipt Printer

- you press a button.
- you connect the printer to external power.
- you are communicating with or sending data to the printer.

You can change the amount of time to have elapse before the backlight turns off using the Setup menu. Options for backlight are always off, always on, 5 seconds, 10 seconds, 20 seconds, 30 seconds, or 60 seconds.

Using the Batteries

The PB22/PB32 uses a rechargeable 2250 mAh lithium-ion battery (Model AB27) for power. You must fully charge the battery before you can use the PB22/PB32. A fully charged battery can last up to one week without needing to be recharged when the printer is in Standby mode.



Caution

Use Intermec Model AB27 battery only. Use of another battery may present a risk of fire or explosion.



Caution

The Model AB27 battery may present a fire or chemical burn hazard if mistreated. Do not disassemble, heat above 100°C (212°F), or incinerate.

Dispose of used batteries promptly. Keep away from children.

Installing the Battery

Make sure you fully charge the battery before you use your PB22/PB32. You can charge the battery before or after you install them into the PB22/PB32.

To install the battery

- 1 Lay the PB22/PB32 upside down on a flat surface.

Chapter 1 – Using the PB22/PB32 Portable Label and Receipt Printer

- 2** Insert the battery with the tab facing away from the front control panel.

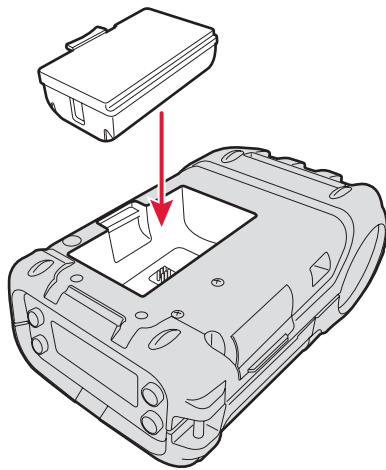

- 3** Insert the edge of the battery under the lip of the PB22/PB32 and then push down until you hear the battery latch click.

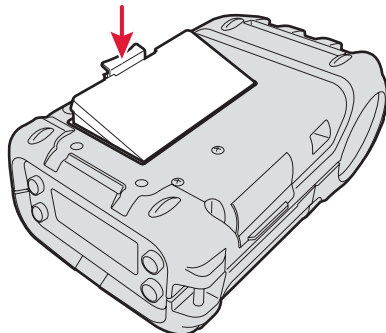

Charging the Batteries

There are two ways to charge the PB22/PB32 battery:

- Connect AC power to the printer using a 12 VDC power supply and charge the battery while it is in the PB22/PB32.
- Charge the battery in the AC18 4-bay battery charger.

For information on charging your battery in the 4-bay battery charger, see the *AC18 4-Bay Battery Charger Instructions* (P/N 943-128-xxx).

It takes approximately 3 hours to charge the battery while it is installed in the PB22/PB32 printer. To charge the battery inside the PB22/PB32, you need:

- an Intermec 12 VDC power supply (Model AE19).
- an AC power cord.



To charge the battery inside the PB22/PB32

- 1 Install the battery in the PB22/PB32. For help, see the previous section, [“Installing the Battery” on page 7](#).
- 2 Connect the power supply to the DC power connector on the printer.
- 3 Connect one end of the power cord to the power supply and then plug the other end into an AC outlet.



Understanding the Battery Icons

The easiest way to tell the status of your battery is to look at the battery icons on the control panel of the PB22/PB32.

Battery Icon Status

Icon	Status
	Battery is fully charged.
	Battery has a medium charge. You should be able to work for several more hours before charging or replacing the battery.
	Battery is low. Recharge the battery.

Battery Icon Status (continued)

Icon	Status
	Battery is critically low. You need to replace the battery now.
	Battery charging error. You may need to replace the battery.
	External power connected and there is no battery in the printer.

Extending Battery Life

Here are some tips for extending the overall life of your battery:

- Never expose the battery to direct sunlight or temperatures over 50°C (122°F).
- Only charge the battery inside the PB22/PB32 using a power supply or in the 4-bay battery charger (Model AC18).
- Do not set the backlight to always on. The always on setting disabled automatic power saving modes.

Here are some tips for extending the life of your battery between charges:

- Press the **Standby** button to put the printer in Standby mode.
- Remove the battery from the printer if you will not be using it for three days or more.
- Do not operate the PB22/PB32 in extremely cold temperatures, the allowable operating cold temperature is -20°C (-4°F). Using the PB22/PB32 in temperatures below freezing reduces the overall battery life.

Remember that any rechargeable battery loses its ability to maintain a charge over time. You can only recharge it a finite number of times before you must replace it.

Loading Media

You can use roll or fanfold receipt media with the PB22/PB32 printer. The PB22/PB32 ships with a small amount of media loaded and a test page printed to verify that the printer works. The PB22/PB32 supports self-strip printing applications. For information on how to correctly load media for self-strip printing, see [“To load media for self-strip printing” on page 14](#). For information on media, see [“Specifications” on page 52](#).

To load media

- 1 Press down on the blue media cover release button until the cover releases.

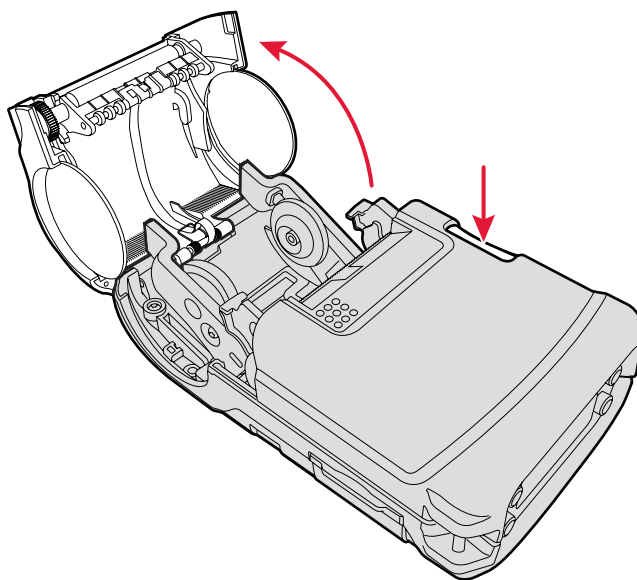

- 2 If necessary, unlock the media support lock before sliding the two media supports apart.

Chapter 1 – Using the PB22/PB32 Portable Label and Receipt Printer

- 3** Insert a roll of media and close the media supports so the roll is held firmly in place. Make sure you load the media clockwise so that it pulls off the core from the bottom of the printer.

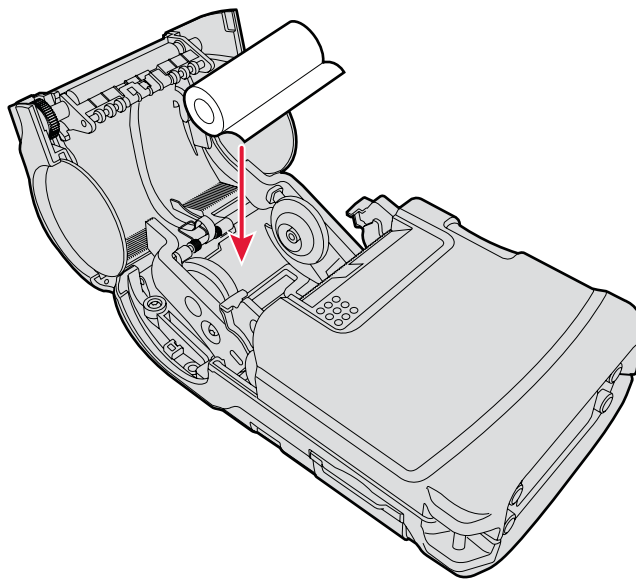

- 4** Lock the media support lock.
- 5** Pull out approximately 8 cm (3 in) of the media.

Chapter 1 – Using the PB22/PB32 Portable Label and Receipt Printer

- 6 Close the media cover until it latches. The printer emits the hardware sound to tell you that the media door closed correctly.

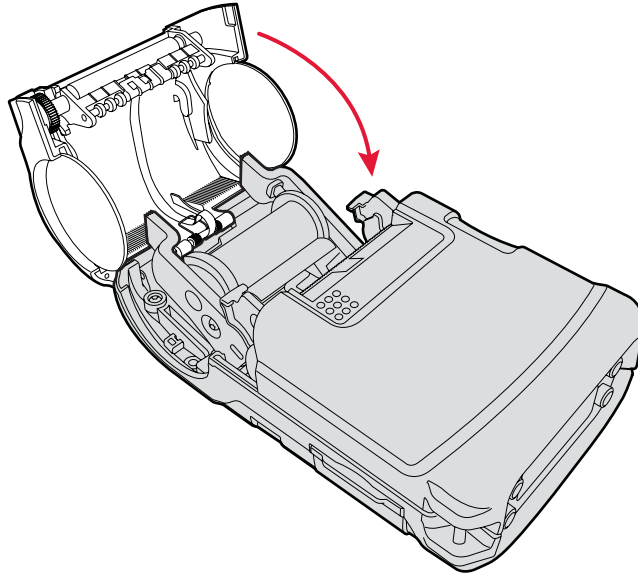

Chapter 1 – Using the PB22/PB32 Portable Label and Receipt Printer

- 7 Press down on the self-strip door to make sure the media cover is completely latched.

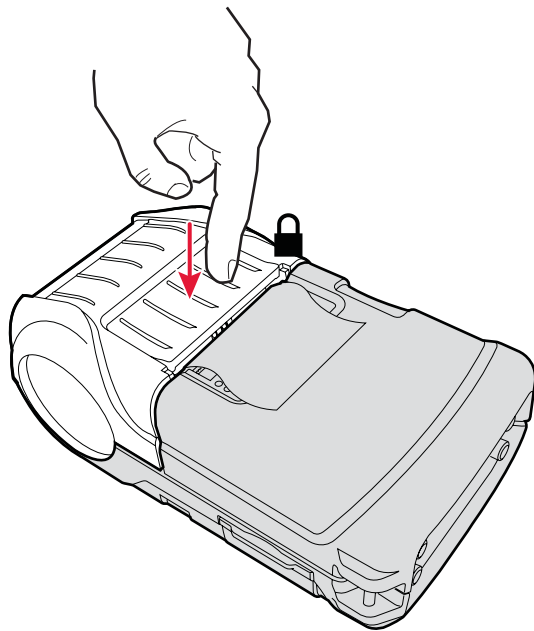

- 8 Press the **Feed** button to advance the media.

To load media for self-strip printing

- 1 Complete Steps 1 through 4 in the previous procedure.
- 2 Open the self-strip door in the media cover.

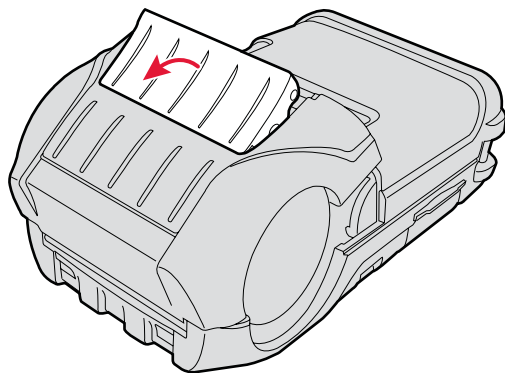

Chapter 1 – Using the PB22/PB32 Portable Label and Receipt Printer

- 3** Remove a label from the roll of media so that you are left with several inches of label liner.
- 4** Feed the label liner over the self-strip bar and out the back of the self-strip door.

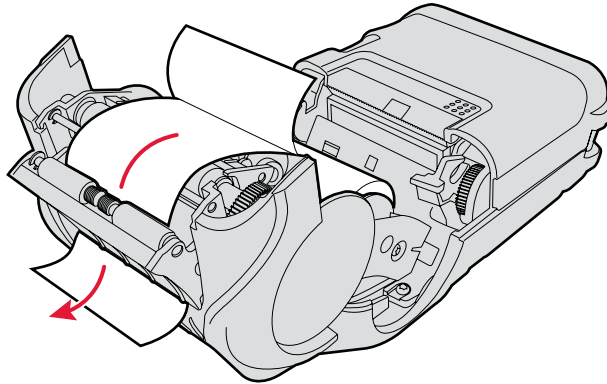

- 5** Close the media cover until it latches and press down on the self-strip door to make sure it locks. The separated liner and media spool from the self-strip mechanism.

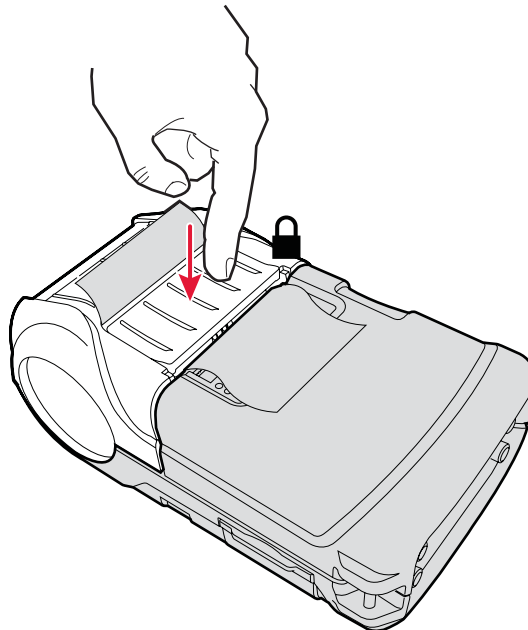

Printing a Test Page

After you have loaded media in the printer, you are ready to print a testprint. You can choose from several testprint options for each type of firmware. If you cannot get the testprint information to print, see [“Troubleshooting the PB22/PB32” on page 42](#).

To print a test print with a PB22/PB32 loaded with IPL firmware

- 1 Press the **Setup** button.
- 2 Press **▶** until you reach **Test/Service**.
- 3 Press **OK** to enter the Test/Service menu system.
- 4 Press **OK** to enter the Testprint Config menu.
- 5 Press **OK** to enter the Config menu.
- 6 Press **▶** to choose a testprint.
- 7 Press **OK** to print the Config testprint of your choice.

To print a testprint with a PB22/PB32 loaded with Fingerprint firmware

- 1 Press the **Setup** button.
- 2 Press **▶** until you reach **Print Defs**.
- 3 Press **OK** to enter the Print Defs menu system.
- 4 Press **▶** until you reach **Testprint**.
- 5 Press **OK** to enter the Testprint menu.
- 6 Press **▶** to choose a testprint.
- 7 Press **OK** to print the testprint of your choice.

To print a self test with a PB50 loaded with ESC/P firmware

- Send the ESC EZ{TP} command to the printer.

3

Troubleshooting and Maintaining the PB22/PB32

Use this chapter to solve problems you may encounter while using the PB22/PB32. You will also find information on booting the printer and routine maintenance.

Troubleshooting the PB22/PB32

You may have printer operation, print quality, or printer communication problems at some time during the life of the PB22/PB32 printer. It is easy to fix most of the problems and you will find solutions in **“Troubleshooting Printer Problems and Finding Solutions” on page 44**. If you cannot find the answer to your problem, you may need to contact Product Support.

Contacting Product Support

Before you call Intermec Product Support, you may want to visit the Intermec technical knowledge base (Knowledge Central) at intermec.custhelp.com to review technical information or to request technical support. If you still need help after visiting Knowledge Central, you may need to call Product Support.

To talk to an Intermec Product Support representative in the U.S.A. or Canada, call:

1-800-755-5505

Outside the U.S.A. and Canada, go to www.intermec.com and click **Contact** to find your local Intermec representative.

Before you call Intermec Product Support, make sure you have the following information ready:

- Printer serial number
- Firmware type and version
- Bluetooth, wireless, or serial port settings









You can find all of the information listed above in the printer menu system or on a test print page.

Understanding Error Messages



Use the following tables to troubleshoot some common error message you may see display on PB22/PB32 screen. Some of the error messages are specific to the type of firmware you have loaded on your PB22/PB32.

Chapter 3 – Troubleshooting and Maintaining the PB22/PB32

Possible PB22/PB32 Error Icons and Messages

Error Icon	Error Message	Description
	Pause	The print job is paused.
	Paper out (IPL) Out of Paper (Fingerprint)	The printer is out of paper. Load a new roll of media. For help, see “Loading Media” on page 11 .
	Testfeed not done	The printer did not perform a test feed before it printed out test labels. It is important to perform a test feed because it calibrates the sensor. To perform a testfeed: <ul style="list-style-type: none">• In Fingerprint, press the Feed button for more than 1 second.• In IPL and ESC/P, open and close the media door and then Press the Feed button.
	Printhead hot	The printhead is overheated and needs to cool down. In IPL, wait for printing to resume automatically. In Fingerprint and ESC/P, your print job is lost.
	Upgrading	The printer is loading new firmware.
	LSS too high, LSS too low	These errors can occur when you run a test feed without any media installed, or if you have incorrect media settings. Load the printer with media (see “Loading Media” on page 11), run Test mode (see “Understanding Test Mode” on page 21), and select the appropriate media type.
	IP configuration error	The printer is trying to acquire an IP address from the network. Wait for the printer to complete the task before taking any action.
	IP link error	No network connection.

Possible PB22/PB32 Error Icons and Messages (continued)

Error Icon	Error Message	Description
	Field out of label	You are attempting to print in an area that extends beyond the print window. See the programmer's reference manual for your type of firmware (IPL, Fingerprint, or ESC/P) for information on how to set the media parameters.
	Printhead lifted	The printer is not completely closed. Press down on the media cover to make sure it is latched.

Troubleshooting Printer Problems and Finding Solutions

Use the following tables to troubleshoot some common problems you may encounter with the PB22/PB32 printer.

Printer Problems and Solutions

Problem	Possible Solution
The printer does not turn on when you press Standby .	<ul style="list-style-type: none"> • Replace the battery with a charged battery. • Connect external power to make sure the printer works correctly and to charge the battery.
The blue light (Ready-to-Work indicator) is blinking.	<ul style="list-style-type: none"> • Make sure media is loaded and the media cover is closed. For help, see “Loading Media” on page 11. • There is a printing error. The screen displays an error message containing information on the error. • The printer is paused. The printer is cancelling a print job.
Printer keeps printing or feeding when it should stop.	<ul style="list-style-type: none"> • Check media settings. • Make sure the label gap sensor is clean. For help, see “Upgrading the Firmware” on page 48.
The printout is not in the desired position.	<ul style="list-style-type: none"> • Check for errors in the software application. • Make sure the label gap sensor and platen roller are clean.

Printer Problems and Solutions (continued)

Problem	Possible Solution
The printer is not printing with an 802.11 wireless connection.	<ul style="list-style-type: none"> • Verify that the wireless settings are correct. For help, see “Setting Up 802.11 Radio Communications” on page 28. • Make sure the printer has an IP address. • Make sure the printer is connected to the network. • Make sure the printer is in Ready mode.
The printer is not printing with a Bluetooth connection.	<ul style="list-style-type: none"> • Re-establish a Bluetooth connection with the mobile computer or scanner. For help, see your mobile computer user’s manual or “Setting Up Bluetooth Communications” on page 27. • Make sure the mobile computer can print to a known good printer. • Print a Bluetooth test print page to make sure that the mobile printer discovered your printer. For help, see “Printing a Test Page” on page 16. • Make sure the printer is in Ready mode.
When printing, the printer is skipping labels.	<p>Perform a testfeed:</p> <ul style="list-style-type: none"> • In Fingerprint, press the Feed button for more than 1 second. • In IPL, open and close the media door and then Press the Feed button. <p>Make sure the label gap sensor is clean. For help, see “Upgrading the Firmware” on page 48.</p>
Printout is faded or weak.	<ul style="list-style-type: none"> • Fingerprint users: adjust the media constant/factor and contrast (-10% to +10%). • IPL users: adjust the media sensitivity setting (-10 to +10). • ESC/P users: adjust the Media Sensitivity command or the Set Dark Adjust command. For help, see the <i>ESC/P Programmer’s Reference Manual</i> (P/N 937-010-xxx). • Check to see if the printhead needs cleaning. For help, see “Upgrading the Firmware” on page 48.

Printer Problems and Solutions (continued)

Problem	Possible Solution
The battery charge is not lasting as long as it should.	<ul style="list-style-type: none">• Check the battery date. If the battery is a few years old, the shortened life may be due to normal aging.• Replace the battery.
The test pages do not print.	<ul style="list-style-type: none">• Make sure that the blue light is not blinking. If it is, make sure your printer has media and that the media cover is closed.• Make sure that you can advance media by pressing the Feed button.
Print quality is poor.	<ul style="list-style-type: none">• Clean the printhead. For help, see “Upgrading the Firmware” on page 48.• Check the battery and recharge or replace as necessary. For help, see “Charging the Batteries” on page 9.• Check the quality of the media. Use only Intermec media to ensure superior print quality and product performance.• Check that the printer is set to the appropriate Constant/Factory or sensitivity number for the media you are using.

Troubleshooting Communication Problems

Use Dump mode to verify that the printer is receiving data from the host correctly.

Using the Line Analyzer in Fingerprint

In Dump mode, the printer runs a Fingerprint program called Line Analyzer. The Line Analyzer captures incoming characters on the communication ports and prints them on one or more labels.

The easiest way to enter Dump mode is through Test mode or Extended Test mode. For help, see **“Understanding Test Mode” on page 21**.

After the printer enters Dump mode, it tells you it has entered Dump mode by printing it on a label. The display shows the Dump mode icon and printer is ready to receive data.

Chapter 3 – Troubleshooting and Maintaining the PB22/PB32

While the printer is receiving data, the Ready-to-Work indicator blinks. After a half of a second, if no more characters have been received, the printer times out. The program considers the transmission terminated and prints out a label.

Printable characters are printed in black-on-white. Control characters and space characters (ASCII 000 to 032 dec) are printed in white-on-black.

As long as a continuous string of characters is being received, the program wraps the lines until the label is full and then starts to print another label. After each character transmission, the following information prints:

- Page number
- Number of characters printed on the label
- Total number of characters received so far

When you exit Dump mode, a final label prints to inform you that it is exiting from Dump mode.

Using Dump Mode in IPL

When you enter Dump mode, the printer captures incoming characters on the communication ports and prints them on one or more labels.

If you have IPL firmware on your printer, you can access Dump mode in two different ways with slightly different results:

- You can access Dump mode through Test mode or Extended Test mode and you will receive printouts that look exactly like those produced with the Line Analyzer program in Fingerprint. For more information, see the previous procedure, [“Using the Line Analyzer in Fingerprint” on page 46](#).
- You can access Dump mode from the Setup menu. If you access Dump mode this way, characters are printed on a continuous line along with corresponding hexadecimal numbers.

To enter Dump mode from the Setup menu

- 1** Press the **Setup** button.
- 2** Press **➤** until you reach **Test/Service**.
- 3** Press **OK** to enter the Test/Service menu.

- 4** Press **>** until you reach **Data Dump** and then press **OK**.
- 5** Press **>** to select Yes and then press **OK**.
- 6** Cold boot the printer to exit Dump mode. For help, see the next procedure, “Cold Booting the PB22/PB32.”

Cold Booting the PB22/PB32

You rarely need to cold boot the PB22/PB32 printer, unless you are upgrading the firmware. If your printer occasionally locks up, you will want to cold boot it. A cold boot reinitializes the 802.11 radio and clears the working memory.



Note: The Setup menu is not affected by a cold boot. Your printer retains all of your configuration settings after the printer powers back up.

To reset the PB22/PB32

- 1** Disconnect the PB22/PB32 from power if externally powered.
- 2** Remove the battery from the PB22/PB32 for at least one second.
- 3** Insert the battery back into the PB22/PB32.
- 4** Reconnect external power if your PB22/PB32 is externally powered.

Upgrading the Firmware

The latest firmware and software is always available for download from the Intermec web site at www.intermec.com.

To download firmware updates

- 1** Go to the Intermec web site at www.intermec.com.
- 2** Click **Support > Downloads**.
- 3** In the **Select a Product** field, choose PB22/PB32 mobile printer. The latest available software displays on the page.
- 4** Download the latest firmware version to your computer. Make sure you choose the correct firmware upgrade for your IPL, Fingerprint, or ESC/P printer.

Chapter 3 – Troubleshooting and Maintaining the PB22/PB32

- 5 Extract the .zip file to a folder on your computer.

You have options for upgrading the firmware based on whether your PB22/PB32 has a Bluetooth radio or an 802.11 b/g radio. Use one of the following procedures to upgrade your printer firmware. Your printer should reboot after you finish upgrading the firmware. If it does not reboot, you will need to cold boot the printer. For help, see **“Cold Booting the PB22/PB32” on page 48.**

To upgrade your printer using PrintSet

- 1 Download the latest version of PrintSet from the Intermec web site at www.intermec.com.
- 2 Select **File > Add Printer** to start the Add Printer Wizard which guides you through the process of adding your printer.
- 3 Select your printer under My Printers and then go to **Printer > Firmware Wizard**.

The Firmware Wizard guides you through the necessary steps to update your firmware.

To upgrade your printer using a serial connection

- 1 Make sure you have established a serial communications between your PC and the PB22/PB32. For help, see **“Setting Up Serial Communications” on page 36.**
- 2 Use Fingerprint, IPL, or ESC/P commands to send the upgrade file to the printer.

For help with Fingerprint, IPL, or ESC/P commands and information, see either the *Fingerprint Programmer's Reference Manual* (P/N 937-005-xxx), the *IPL Programmer's Reference Manual* (P/N 937-007-xxx), or the *ESC/P Programmer's Reference Manual* (P/N 937-010-xxx). You can download these documents from the Intermec web site at www.intermec.com.

Cleaning the Printer

To properly maintain your PB22/PB32, you should clean it at the recommended intervals.



Warning

To avoid possible personal injury or damage to the printer, never insert any pointed or sharp objects into the printer.



Caution

Use only the cleaning agents specified in this section. Intermec is not responsible for damage caused by any other cleaning materials used on this printer. Clean the printer with a cotton swab saturated with alcohol.

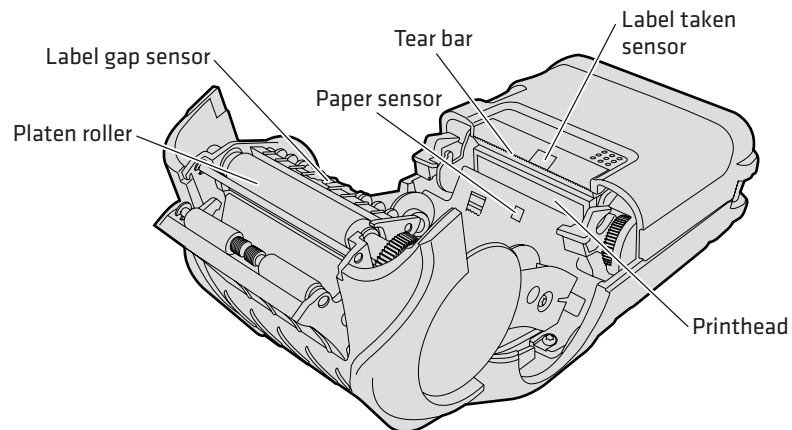

PB22/PB32 Mobile Label Printer: Identifying the parts of the PB22/PB32 to clean regularly

Cleaning the PB22/PB32 Printer

Printer Part	Cleaning Method	Cleaning Interval
Printhead	Use 70% isopropyl alcohol on a cotton swab to clean the print elements from end to end.	After every five rolls of media or more often if necessary.

Chapter 3 – Troubleshooting and Maintaining the PB22/PB32

Cleaning the PB22/PB32 Printer

Printer Part	Cleaning Method	Cleaning Interval
Platen roller	Rotate the platen roller and clean it thoroughly with 70% isopropyl alcohol on a cotton swab.	After every five rolls of media or more often if necessary.
Paper sensors	Clean thoroughly with 70% isopropyl alcohol and a cotton swab.	After every five rolls of media or more often if necessary.
Tear bar	Clean thoroughly with 70% isopropyl alcohol and a cotton swab.	As needed.
Exterior	Clean with a water-dampened cloth.	As needed.
Interior	Brush or air blow. Make sure the paper sensor is free of dust.	After every five rolls of media or more often if necessary.

Chapter 3 – Troubleshooting and Maintaining the PB22/PB32



A Specifications

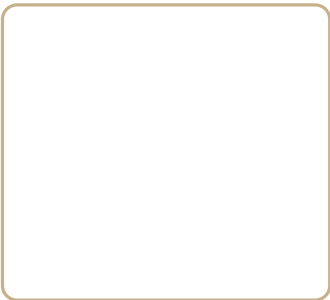

Specifications

Physical Dimensions

PB22

Depth:	71.1 mm (2.8 in)
Height:	176.4 mm (6.9 in)
Width:	101.6 mm (4.0 in)
Weight:	450 g (1 lb) with battery

PB32

Depth:	81.6 mm (3.21 in)
Height:	182.2 mm (7.2 in)
Width:	127.6 mm (5.0 in)
Weight:	700 g (1.54 lb) with battery

Power Specifications

AC power adapter voltage:	100 to 240 V, 43 to 63 Hz
Printer voltage:	12 VDC and 50 Hz to 60 Hz
Operating power:	Rechargeable 7.2 V 2250 mAh lithium-ion battery

Temperature and Humidity Specifications

Operating temperature:	-20°C to 50°C (-4°F to 122°F)
Storage temperature:	-40°C to 70°C (-40°F to 158°F)
Charging temperature:	0°C to 45°C (32°F to 113°F)
Relative humidity:	10 to 90% non-condensing
Sealing:	IP54

Memory

RAM:	16 MB
Flash:	64 MB

Print Speed and Resolution

Print speed:	4 ips (100 mm/s)
Resolution:	203 dpi (8 dots/mm)

Print Technology

Printhead:	Direct thermal
Maximum print width:	PB22 55.88 mm (2.2 in) PB32 83.82 mm (3.3 in)

Media Specifications

Minimum gap and black mark length:	3.17 mm (0.125 in)
Minimum gap, black mark, and notch length:	12.7 mm (0.50 in)
Minimum notch length:	6.35 mm (0.25 in)
Minimum notch width:	12.7 mm (0.50 in)
Black mark width:	Full width of media
Core inside diameter:	19.05 mm (0.75 in) 10.16 mm (0.40 in for receipt paper)
Roll outside diameter:	PB22 57.15 mm (2.25 in) PB32 67.31 mm (2.65 in)
Tracking1	Center
Minimum caliper for label with liner and receipts:	0.05 mm (0.002 in)
Maximum caliper for label with liner and receipts:	0.165 mm (0.0065 in)
Maximum caliper for tags:	0.15 mm (0.006 in)
Minimum media length:	12.7 mm (0.5 in)
Maximum media length:	Continuous

Receipt roll stock media is supplied as a continuous roll. Label, tag, and fanfold media use repeat indicators for non-continuous media. Gap, notch, and black marks are used as repeat indicators:

- **Gap:** Label and fanfold media
- **Notch:** Tag media
- **Black mark:** Label, tag, and fanfold media

Chapter A – Specifications

Here are a few things to keep in mind when ordering media for the PB22/PB32 printer:

- Black marks can only be sensed on the back side of the media.
- You can use higher caliper media in the printer, but print quality will be reduced.
- Receipt roll stock media has an end of roll indicator. The end of roll indicator is a red marking (on last 3 feet of roll) on the thermally sensitive side of the paper.

External Fanfold Media Specifications

Stack height:	70 mm (2.75 in)
Page length:	152 mm (6 in) to 305 mm (12 in)



Note: A 6-inch page length is supplied in 12-inch long stacks (two 6-inch stacks of equal height with the bottom page linked).

Specialty media is required for unique customer environments, including printer operating temperature extremes. Intermec recommends that you test the media in your application.

Supported Media

The PB22/PB32 printer supports direct thermal label, tag, and receipt media. Both North American and European label media are supported in multiple label lengths. Receipt media is supported in both a top coated and an uncoated paper in continuous roll stock only.

The default media sensitivity number is: 180.

Use the following table as a guide when setting sensitivity numbers.

Recommended Media Sensitivity and Constant

Sensitivity	Constant	Description
North American Label Media		
720	60	Duratherm Lightning Plus
470	52	Duratherm Lightning Perm
450	48	Duratherm III IR

Recommended Media Sensitivity and Constant (continued)

Sensitivity	Constant	Description
430	100	Duratherm III Synthetic
180	80	Duratherm II Label
180	80	Duratherm III Label
180	80	Duratherm Near IR
150	50	Duratherm 5 mil Tag
180	80	Duratherm II Floodcoated (NTC)
180	80	Duratherm III Floodcoated (TC)
420	63	Duratherm III NIR Floodcoated (FedEx)
North America Receipt Media		
401	45	Duratherm TC
102	32	Duratherm NTC - 2
101	30	Duratherm NTC
101	30	Duratherm Receipt - Fanfold
103	75	Duratherm Linerless
European Label Media		
440	47	Thermal Eco
140	70	Thermal Top
120	67	Thermal Eco Board 140 gr

Accessories for the PB22/PB32

You can use these accessories with the PB22/PB32 printer. To order accessories, contact your local Intermec sales representative.

AB27 Battery

Use the lithium-ion 2250 mAh battery to provide power to the printer.

AC18 4-Bay Battery Charger

Use the AC18 to charge up to four batteries at a time. The battery charger is designed to sense when a battery is fully charged and not overcharge it, ensuring long and consistent battery life.

Chapter A – Specifications

AV14 Vehicle Dock

Use the vehicle dock to attach the PB22/PB32 to a truck.

Belt Clip

Use the PB22/PB32 belt clip to attach the printer to your belt.

Handstrap

Use the PB42 and PB22/PB32 handstrap to conveniently carry your PB22/PB32 printer. With the handstrap attached, you can also attach the shoulder strap.

Power Supply (Model AE19)

Provides power to the PB22/PB32 and the 4-bay battery charger (Model AC18).

Serial Cable

The serial adapter is an 8-pin DIN to DB9 connector that connects from the PB22/PB32 printer to your desktop PC.

Shoulder Strap

Use the shoulder strap in combination with the handstrap to easily carry the PB22/PB32 printer. The wide padded strap makes it comfortable to wear the printer for long periods of time.

Cart Mount

Stands the printer vertically when placed on a flat surface. Excellent for cart or desktop use.