

The Intermec logo is displayed in a bold, blue, sans-serif font. It is positioned to the left of a decorative graphic consisting of several overlapping, light blue circles and lines that form a stylized orbital or network pattern. A vertical red line extends from the top of this graphic down towards the bottom of the page.

**Intermec**



**User's Guide**



**PB50 Portable Label  
Printer**

Intermec Technologies Corporation

Worldwide Headquarters  
6001 36th Ave.W.  
Everett, WA 98203  
U.S.A.

[www.intermec.com](http://www.intermec.com)

The information contained herein is provided solely for the purpose of allowing customers to operate and service Intermec-manufactured equipment and is not to be released, reproduced, or used for any other purpose without written permission of Intermec Technologies Corporation.

Information and specifications contained in this document are subject to change without prior noticed and do not represent a commitment on the part of Intermec Technologies Corporation.

© 2007 by Intermec Technologies Corporation. All rights reserved.

The word Intermec, the Intermec logo, Norand, ArciTech, Beverage Routebook, CrossBar, dcBrowser, Duratherm, EasyADC, EasyCoder, EasySet, Fingerprint, i-gistics, INCA (under license), Intellitag, Intellitag Gen2, JANUS, LabelShop, MobileLAN, Picolink, Ready-to-Work, RoutePower, Sabre, ScanPlus, ShopScan, Smart Mobile Computing, SmartSystems, TE 2000, Trakker Antares, and Vista Powered are either trademarks or registered trademarks of Intermec Technologies Corporation.

There are U.S. and foreign patents as well as U.S. and foreign patents pending.

Wi-Fi is a registered certification mark of the Wi-Fi Alliance.

Bluetooth is a trademark of Bluetooth SIG, Inc., U.S.A.

# Contents

Before You Begin . . . . .	iv
Safety Information . . . . .	iv
Global Services and Support . . . . .	iv
Warranty Information . . . . .	iv
Web Support . . . . .	v
Telephone Support . . . . .	v
Service Location Support . . . . .	vi
Who Should Read This Manual . . . . .	vi
Related Documents . . . . .	vi
<b>1 Using the PB50 Portable Label Printer . . . . .</b>	<b>1</b>
Learning About the PB50 Portable Label Printer . . . . .	2
Identifying the Parts of the Printer . . . . .	2
Understanding the Printer Firmware . . . . .	2
Understanding the Control Panel . . . . .	3
Understanding the Printer Sounds . . . . .	5
Understanding the Backlight . . . . .	6
Using the Batteries . . . . .	6
Installing the Battery . . . . .	6
Charging the Batteries . . . . .	7
Understanding the Battery Icons . . . . .	8
Extending Battery Life . . . . .	8
Loading Media . . . . .	9
Printing a Test Page . . . . .	13
<b>2 Configuring the PB50 . . . . .</b>	<b>15</b>
Configuring the PB50 . . . . .	16
Understanding the Display Modes . . . . .	16
Understanding Ready Mode . . . . .	16
Understanding Information Mode . . . . .	16
Understanding Pause Mode . . . . .	17
Understanding Setup Mode . . . . .	17
Understanding Error Mode . . . . .	19
Understanding Test Mode . . . . .	19
Changing Configuration Settings . . . . .	21
Changing the Configuration Settings From the Display . . . . .	21
Changing the Configuration Settings from PrintSet . . . . .	23

## Contents

Changing the Configuration Settings Using the Command Line . . . . .	23
Changing Configuration Settings from the Printer Home Page . . . . .	24
Changing Configuration Settings from SmartSystems Console . . . . .	24
Establishing Communications With a Host . . . . .	24
Setting Up Bluetooth Communications . . . . .	25
Setting Up 802.11 Radio Communications . . . . .	26
Configuring Wireless Printing Using IPL . . . . .	29
Configuring Wireless Printing Using Fingerprint . . . . .	31
Setting Up Serial Communications . . . . .	33
Upgrading the Firmware . . . . .	34
Downloading Fonts and Graphics . . . . .	35
<b>3 Troubleshooting and Maintaining the PB50 . . . . .</b>	<b>37</b>
Troubleshooting the PB50 . . . . .	38
Contacting Product Support . . . . .	38
Understanding Error Messages . . . . .	38
Troubleshooting Printer Problems and Finding Solutions . . . . .	40
Troubleshooting Communication Problems . . . . .	42
Using the Line Analyzer in Fingerprint . . . . .	42
Using Dump Mode in IPL . . . . .	42
Cold Booting the PB50 . . . . .	43
Cleaning the Printer . . . . .	44
<b>A Specifications . . . . .</b>	<b>47</b>
Specifications . . . . .	48
Accessories for the PB50 . . . . .	50
<b>B IPL and Fingerprint Setup Menus . . . . .</b>	<b>53</b>
IPL Setup Menu . . . . .	54
Fingerprint Setup Menu . . . . .	55

## Before You Begin

This section provides you with safety information, technical support information, and sources for additional product information.

### Safety Information

Your safety is extremely important. Read and follow all warnings and cautions in this document before handling and operating Intermec equipment. You can be seriously injured, and equipment and data can be damaged if you do not follow the safety warnings and cautions.

This section explains how to identify and understand dangers, warnings, cautions, and notes that are in this document. You may also see icons that tell you when to follow ESD procedures and when to take special precautions for handling optical parts.



Warning

**A warning alerts you of an operating procedure, practice, condition, or statement that must be strictly observed to avoid death or serious injury to the persons working on the equipment.**



Caution

**A caution alerts you to an operating procedure, practice, condition, or statement that must be strictly observed to prevent equipment damage or destruction, or corruption or loss of data.**



**Note:** Notes either provide extra information about a topic or contain special instructions for handling a particular condition or set of circumstances.

### Global Services and Support

#### Warranty Information

To understand the warranty for your Intermec product, visit the Intermec web site at [www.intermec.com](http://www.intermec.com) and click **Support > Returns and Repairs > Warranty**.

**Web Support**

Visit the Intermec web site at [www.intermec.com](http://www.intermec.com) to download our current manuals (in PDF). To order printed versions of the Intermec manuals, contact your local Intermec representative or distributor.

Visit the Intermec technical knowledge base (Knowledge Central) at [intermec.custhelp.com](http://intermec.custhelp.com) to review technical information or to request technical support for your Intermec product.

**Telephone Support**

These services are available from Intermec.

<b>Services</b>	<b>Description</b>	<b>In the USA and Canada call 1-800-755-5505 and choose this option</b>
Order Intermec products	<ul style="list-style-type: none"><li>Place an order.</li><li>Ask about an existing order.</li></ul>	1 and then choose 2
Order Intermec media	Order printer labels and ribbons.	1 and then choose 1
Order spare parts	Order spare parts.	1 or 2 and then choose 4
Technical Support	Talk to technical support about your Intermec product.	2 and then choose 2
Service	<ul style="list-style-type: none"><li>Get a return authorization number for authorized service center repair.</li><li>Request an on-site repair technician.</li></ul>	2 and then choose 1
Service contracts	<ul style="list-style-type: none"><li>Ask about an existing contract.</li><li>Renew a contract.</li><li>Inquire about repair billing or other service invoicing questions.</li></ul>	1 or 2 and then choose 3

Outside the U.S.A. and Canada, contact your local Intermec representative. To search for your local representative, from the Intermec web site, click **Contact**.

### **Service Location Support**

For technical support in South Korea, use the after service locations listed below:

#### **AWOO Systems**

102-1304 SK Ventium  
522 Dangjung-dong  
Gunpo-si, Gyeonggi-do Korea, South 435-776  
Contact: Mr. Sinbum Kang  
Telephone: +82-31-436-1191  
Email: [sbkang@awoo.co.kr](mailto:sbkang@awoo.co.kr)

#### **Sammi Information Systems Co Ltd**

7-9FL, Seo Jo Building  
103-15, Galwor-Dong  
Seoul, Yong San-ku Korea, South 140-807  
Contact: Kyung-Hee Koo  
Telephone: +82-2-790-5508  
Email: [jlovekoo@sammicomputer.co.kr](mailto:jlovekoo@sammicomputer.co.kr)

## **Who Should Read This Manual**

This user's guide is for the person who is responsible for installing, configuring, and maintaining the PB50 printer.

This guide provides you with information about the features of the PB50, and how to install, configure, operate, maintain, and troubleshoot it.

Before you work with the PB50, you should be familiar with your network and general networking terms, such as IP address.

## **Related Documents**

This table contains a list of related Intermec documents and their part numbers.

<b>Document Title</b>	<b>Part Number</b>
<i>Intermec Fingerprint Programmer's Reference Manual</i>	937-005-xxx
<i>Intermec Printer Language (IPL) Command Reference Manual</i>	066396

## ***Before You Begin***

The Intermec web site at [www.intermec.com](http://www.intermec.com) contains our documents (as PDF files) that you can download for free.

### **To download documents**

- 1** Visit the Intermec web site at [www.intermec.com](http://www.intermec.com).
- 2** Click **Support > Manuals**.
- 3** In the **Select a Product** field, choose the product whose documentation you want to download.

To order printed versions of the Intermec manuals, contact your local Intermec representative or distributor.





# **1 Using the PB50 Portable Label Printer**

## Learning About the PB50 Portable Label Printer

The PB50 is a rugged direct thermal label and receipt printer that is designed for use with the CK31, 700 series, CK61, CN2B, and CN3 handheld computers as well as the SF51 and SR61. scanners. The PB50 provides:

- print resolution of 203 dpi.
- print speeds of up to 75 mm per second (3 ips)
- 802.11 or Bluetooth radio options.

### Identifying the Parts of the Printer

Use this illustrations to familiarize yourself with some of the features of the PB50.

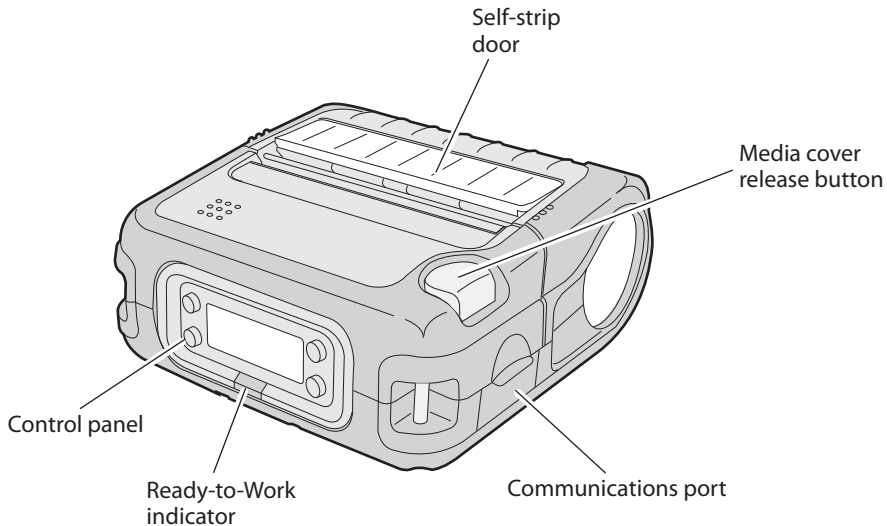

**PB50 Printer:** This illustration shows the important features of the PB50 printer. A weather-resistant flap protects the communications port.

### Understanding the Printer Firmware

Your PB50 printer comes with either Intermec Printer Language (IPL) or Fingerprint firmware. The choice of firmware affects the functionality of the printer and how you interact with it. This manual contains information for using both types of printer firmware.

The current firmware type and version display on the PB50 screen when the printer is in Ready mode.

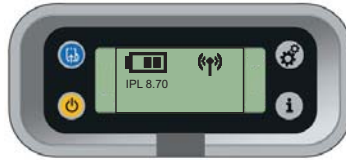

**The screen of a PB50 running IPL firmware**



## Understanding the Control Panel

The PB50 control panel contains four buttons, a liquid crystal display (LCD), and one LED indicator. Use the four buttons to navigate the menu system and perform functions on the PB50 printer. See the following tables to understand the buttons, the menu system, and what the LED means.





**PB50 Control Panel:** Use this illustration to familiarize yourself with the buttons and lights on the PB50.

## Understanding How to Use the PB50 Buttons











Button Name	Button	Function
Feed		Press to advance label or receipt paper by 5 mm (0.19 inch).  If the printer is printing, pressing this button causes the printer to pause. Press the button again to resume printing.
Setup		Press to display the Setup menu.

### Understanding How to Use the PB50 Buttons (continued)

Button Name	Button	Function
Standby (Power)		Press to put the printer in Standby mode. In Standby mode, power to the radio, the display, and the backlight are turned off.  Press to turn the printer back on and put in Ready mode.
Info		Press to display a summary of network connection information. Each setting in the summary information displays on the screen for five seconds.

All of the buttons can act as “soft keys,” which means that the function of each button depends on the state of the printer. A small icon appears in the screen next to the button to indicate the function it performs.

### Understanding the Soft Keys

Button	Soft Key(s)	Description
		<ul style="list-style-type: none"> <li>Moves up one level in the menu system. This soft key appears in Setup mode.</li> </ul>
		<ul style="list-style-type: none"> <li>Increases the value of a number when editing settings such as an IP address. This soft key appears in Setup mode.</li> </ul>
		<ul style="list-style-type: none"> <li>Pauses the printing job.</li> </ul>
		Exit Setup mode and return to Ready mode.
		Moves through the settings at the same level in the menu system.
		<ul style="list-style-type: none"> <li>OK</li> <li></li> </ul>

There is only one LED on the PB50 printer: the Ready-to-Work™ indicator.

### ***Understanding the Ready-to-Work Indicator***

<b>Indicator State</b>	<b>Description</b>
Off	The PB50 is not connected to a host through the radio or serial cable.
On	The PB50 is connected to a radio or the serial port is enabled.
Blinking	A blinking light can mean one of several conditions: <ul style="list-style-type: none"><li>• The printer is out of paper.</li><li>• The media cover is open.</li><li>• There is a printer hardware error. For a list of possible problems, see <a href="#">“Troubleshooting the PB50” on page 38</a>.</li></ul>

## **Understanding the Printer Sounds**

The PB50 plays sounds in response to several actions that you can take with the printer. Use the following table to understand when the sounds occur and what they mean.

### ***Understanding the Printer Sounds***

<b>Sound</b>	<b>Occurs when:</b>
Power	<ul style="list-style-type: none"><li>• You insert a battery in the printer.</li><li>• The PB50 starts charging the battery.</li><li>• You plug in the AC adaptor.</li></ul>
Hardware	You open or close the media door.
Button	You press any of the PB50 buttons.
Error	<ul style="list-style-type: none"><li>• The paper is not feeding out of the printer because the media door is open or the printer is out of paper.</li><li>• A print job failed because the media door is open or the printer is out of paper.</li></ul>

## Understanding the Backlight

The screen backlight on the PB50 behaves the same way as a screensaver on your PC. After a set amount of time elapses without any user interaction, the backlight goes off. The screen backlight turns on when:

- the printer begins printing.
- you press a button.
- you connect the printer to external power.

You can change the amount of time to have elapse before the backlight turns off using the Setup menu. Options for backlight are always off, always on, 5 seconds, 10 seconds, 20 seconds, 30 seconds, or 60 seconds.

## Using the Batteries

The PB50 uses a rechargeable 2200 mAh lithium-ion battery (Model AB13) for power. You must fully charge the battery before you can use the PB50. A fully charged battery can last up to one week without needing to be recharged.



Caution

**Use Intermec Model AB13 battery only. Use of another battery may present a risk of fire or explosion.**



Caution

**The Model AB13 battery may present a fire or chemical burn hazard if mistreated. Do not disassemble, heat above 100°C (212°F), or incinerate.**

Dispose of used batteries promptly. Keep away from children.

## Installing the Battery

Make sure you fully charge the battery before you use your PB50. You can charge the battery before or after you install them into the PB50.

### To install the battery

- 1 Lay the PB50 upside down on a flat surface.

- 2 Insert the battery with the tab facing away from the front control panel.

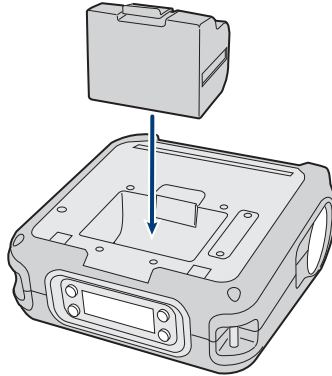

- 3 Insert the edge of the battery under the lip of the PB50 and then push down until you hear the battery latch click.

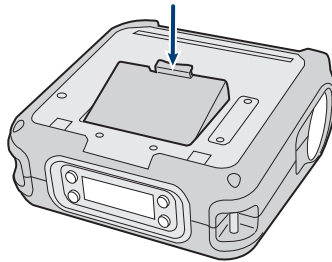

## **Charging the Batteries**

There are two ways to charge the PB50 battery:

- connect AC power to the printer and charge the battery while it is in the PB50.
- Charge the battery in the AC18 4-bay battery charger.

For information on charging your battery in the 4-bay battery charger, see the *AC18 4-Bay Battery Charger Instructions* (P/N 943-128-001).

It takes approximately 4 hours to charge the battery while it is installed in the PB50 printer. To charge the battery inside the PB50, you need:

- an Intermec 12 VDC power supply (Model AE19).

- an AC power cord.







### To charge the battery inside the PB50

- 1 Install the battery in the PB50. For help, see the previous section, “Installing the Battery.”
- 2 Connect the power supply to the DC power connector on the printer.
- 3 Connect one end of the power cord to the power supply and then plug the other end into an AC outlet.

## Understanding the Battery Icons

The easiest way to tell the status of your battery is to look at the battery icons on the control panel of the PB50.

### Battery Icon Status

Icon	Status
	Battery is fully charged.
	Battery has a medium charge. You should be able to work for several more hours before charging or replacing the battery.
	Battery is low. You need to replace the battery soon.
	Battery is critically low. You need to replace the battery now.
	Battery charging error. You may need to replace the battery.
	External power connected and there is no battery in the printer.

## Extending Battery Life

Here are some tips for extending the overall life of your battery:

- Never expose the battery to direct sunlight or temperatures over 40°C (104°F).
- Only charge the battery inside the PB50 using a power supply or in the 4-bay battery charger (Model AC18).



Here are some tips for extending the life of your battery between charges:

- Press the **Standby** button to put the printer in Standby mode.
- Remove the battery from the printer if you will not be using it for three days or more.
- Do not operate the PB50 in extremely cold temperatures. Using the PB50 in temperatures below freezing reduces the overall battery life.

Remember that any rechargeable battery loses its ability to maintain a charge over time. You can only recharge it a finite number of times before you must replace it.

## **Loading Media**

You can use roll or fanfold receipt media with the PB50 printer. The PB50 ships with a small amount of media loaded and a test page printed to verify that the printer works. The PB50 supports self-strip printing applications. See the second procedure for information on how to correctly load media for self-strip printing.

For information on media specifications, see Appendix A.

### **To load media**

- 1 Press down on the blue media cover release button until the cover releases.

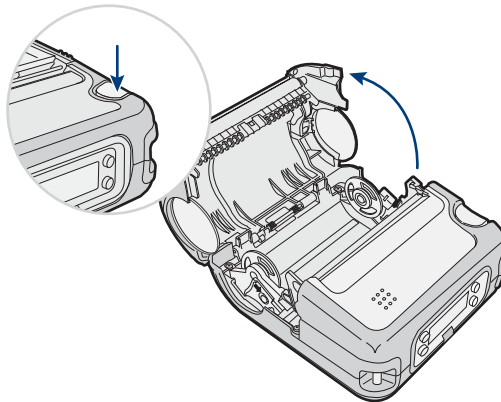

- 2 Press down on the media adjust guide and slide the two media supports apart.

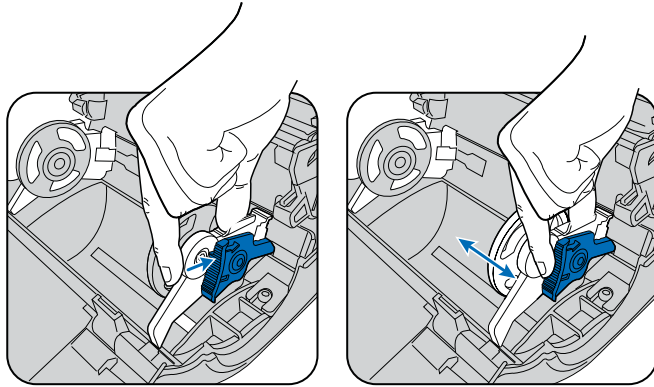

- 3 Insert a roll of media and press the media adjust guide until the roll is held firmly in place. Make sure you load the media clockwise so that it pulls off the core from the bottom of the printer.

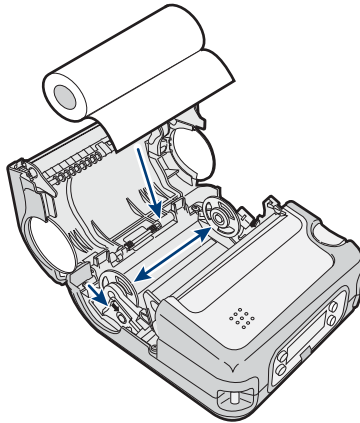

- 4 Pull out a few inches of the media.

- 5 Close the media cover until it latches. The printer emits the hardware sound to tell you that the media door closed correctly.

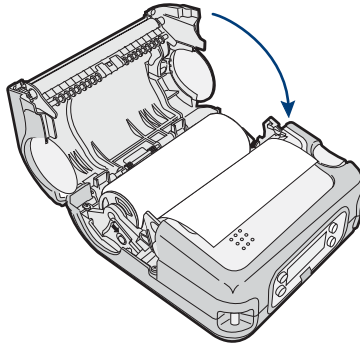

- 6 Press down on the self-strip door to make sure the media cover is completely latched.

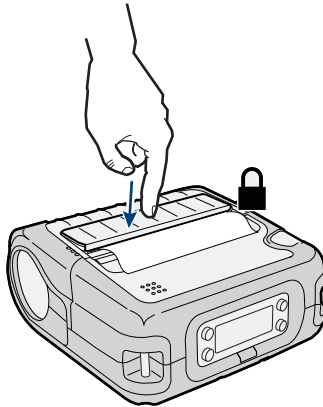

- 7 Press the **Feed** button several times to advance the media.

**To load media for self-strip printing**

- 1 Complete Steps 1 through 4 in the previous procedure.
- 2 Open the self-strip door in the media cover.

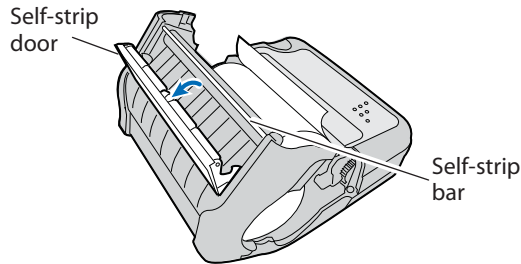

- 3 Remove a label from the roll of media so that you are left with several inches of label liner.
- 4 Feed the label liner over the self-strip bar and out the back of the self-strip door.

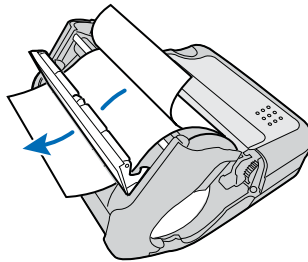

- 5 Close the media cover until it latches and press down on the self-strip door to make sure it locks.

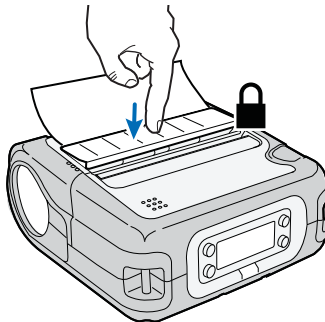

## Printing a Test Page

After you have loaded media in the printer, you are ready to print a testprint. You can choose from several different testprints including: setup info, hardware info, Bluetooth info, network info, diamonds, chess, bar codes #1, and bar codes #2. If you cannot get the testprint information to print, see “Troubleshooting the PB50” in Chapter 3.

### To print a test print with a PB50 loaded with IPL firmware

- 1 Press the **Setup** button.
- 2 Press **▶** until you reach **Test/Service**.
- 3 Press **OK** to enter the Test/Service menu system.
- 4 Press **OK** to enter the Testprint Config menu.
- 5 Press **OK** to enter the Config menu.
- 6 Press **▶** to choose a testprint.
- 7 Press **OK** to print the Config testprint of your choice.

### To print a testprint with a PB50 loaded with Fingerprint firmware

- 1 Press the **Setup** button.
- 2 Press **▶** until you reach **Print Defs**.
- 3 Press **OK** to enter the Print Defs menu system.
- 4 Press **▶** until you reach **Testprint**.
- 5 Press **OK** to enter the Testprint menu.
- 6 Press **▶** to choose a testprint.
- 7 Press **OK** to print the testprint of your choice.

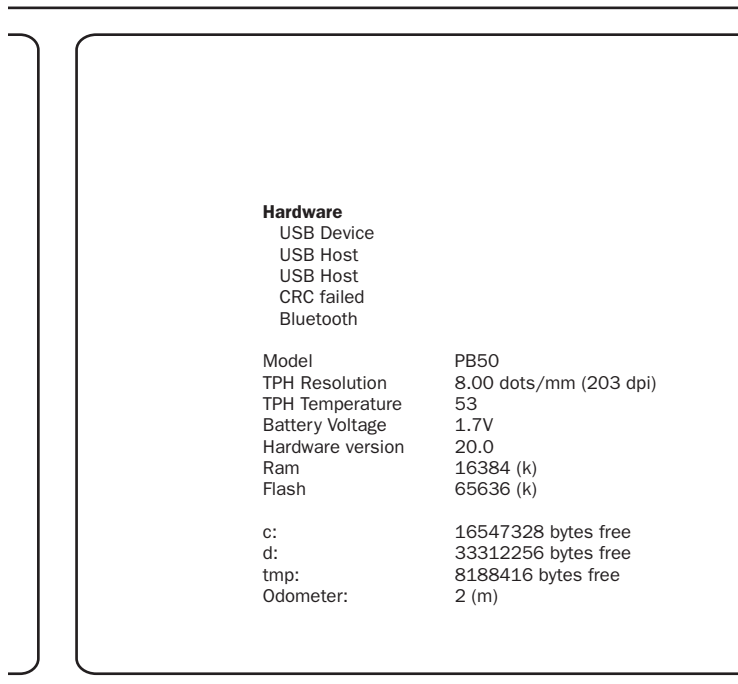

**Sample Network Test Print Page**



## 2 Configuring the PB50

In this chapter you will find these sections:

- Configuring the PB50
- Establishing Communications With a Host
- Upgrading the Firmware
- Downloading Fonts and Graphics

## Configuring the PB50

There are several different ways you can change the configuration settings of the printer. You can change them directly from the display, or remotely from the SmartSystems console.

For more information on the IPL menu system, see Appendix B, “IPL and Fingerprint Setup Menus.”

### Understanding the Display Modes

The PB50 has six display modes to help you effectively interact with the printer: Ready, Information, Paused, Setup, Error, and Test. Use the following sections to understand the different printer modes

#### Understanding Ready Mode

The printer is in Ready mode when the printer is on and ready to print. The main screen displays the power status, the radio status, and the printer language and version.

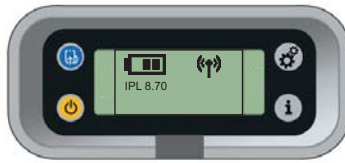

*The PB50 in Ready Mode*

#### Understanding Information Mode

When the printer is in Information mode, it displays a subset of pertinent information about the printer. If the printer experienced an error, the error message displays first followed by the printer information. Each message displays on the screen for five seconds. After five seconds on the last information screen, the printer exits Information mode.

#### To enter Information mode

- Press the **Information** button on the control panel.



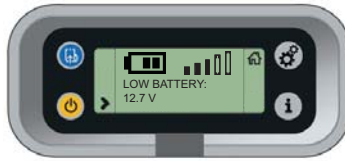

*The PB50 in Information Mode*

### Understanding Pause Mode

Use Pause mode to momentarily stop printing or to cancel a current print job. Once you pause the printer, the Pause mode screen appears. Use the **Feed** button to both pause and resume printing.

#### To enter Pause mode

- Press the **Feed** button while the printer is printing.

#### To resume printing

- Press the **Feed** button (or **||** soft key).

#### To cancel a print job

- 1 Press the **Feed** button to pause printing.
- 2 Press the **Information** button (or **⊗** soft key) to cancel the print job.

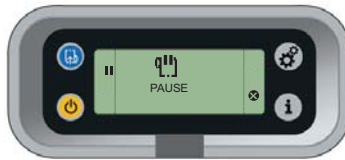

*The PB50 in Pause Mode*

### Understanding Setup Mode

Use Setup mode to change the settings on the printer.

#### To enter or exit Setup mode

- Press the **Setup** button.



**Sample Setup Mode Screen**

Once you enter Setup mode, there are two editing modes: normal and enhanced.

### **Editing Settings in Setup Mode**

<b>Editing Mode</b>	<b>To Navigate</b>	<b>To Accept Value</b>
Normal	<ul style="list-style-type: none"><li>• Press <b>&gt;</b> to move among choices.</li><li>• Press <b>▲</b> to go up a level in menu system.</li></ul>	Press <b>OK</b> .
Enhanced	<ul style="list-style-type: none"><li>• Press <b>&gt;</b> to move within the editable fields. When the field blinks, you can edit it.</li><li>• Press <b>+</b> to increase the value of the field.</li></ul>	Press <b>OK</b> .

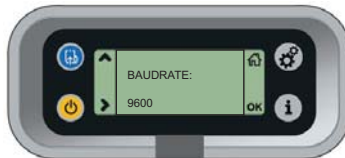

**Normal Editing Mode:** In normal editing mode, you see an up arrow and a right arrow for making selections.



**Enhanced Editing Mode:** In enhanced editing mode you have a plus sign and a right arrow to change the value of numeric fields.

## Understanding Error Mode

The printer enters Error mode when it detects an error condition such as a low battery or a paper fault. Some error messages appear on the screen immediately when they occur, such as DOOR OPEN. Other error messages do not appear until you press the **Information** button. If there is more than one error at a given time, the highest priority error message displays first.



**Sample Error Mode Screen**

If you encounter an error message, see [“Understanding Error Messages” on page 38](#) for information on how to fix the problem.

## Understanding Test Mode

Use Test mode when you want to verify printer settings, print test labels, restore factory default settings, or enter Dump mode for troubleshooting purposes. Two test modes are available: Test mode and Extended Test mode.

### Using Test Mode

Test mode is a simple sequence of events which requires little user interaction. Extended Test mode requires more user interaction and lets you choose which actions you want the printer to perform.

### To enter Test mode

- 1 Make sure the printer is in Ready mode and is loaded with media.
- 2 Press the **Feed** and **Standby** buttons at the same time and hold until Select Media appears on the screen and it displays the time of media you are using (gap, mark, or continuous).
- 3 Release both buttons. The printer performs a test feed (sensor calibration), prints a series of test labels, and then enters Dump mode.

The printer is now in Dump mode and it scans the communication ports. Any characters received on the

communication ports are printed on a label when you exit Dump mode.

- 4 Press **Feed** to exit Dump mode.

After you exit Dump mode, the printer returns to Ready mode. For more information on Dump mode, see “[Troubleshooting Communication Problems](#)” on page 42.

### **Using Extended Test Mode**

You can use Extended Test mode to run additional diagnostic tests. Additional options include printing specific test labels, entering Dump mode, and resetting to factory defaults.

#### **To enter Extended Test mode**

- 1 Make sure that the printer is loaded with media.
- 2 Press the media cover release button to open the media cover.
- 3 Press the **Standby** button to turn the printer off.
- 4 Press **Feed** and **Standby** buttons at the same time until CLOSE PRINTER DOOR appears on the screen.
- 5 Close the media cover. You are now in Extended Test mode.
  - Press **▶** to cycle through the options.
  - Press **OK** to select a test option.
  - Press **Home** to exit Extended Test mode.



***Sample Extended Test Mode Screen***

**Options in Extended Test Mode**

Function	Description
Select Media	This option is almost the same as the process in Test mode, except that the printer performs a slow test feed in Extended Test mode. The slow test feed enables the printer to perform a slow sensor calibration which can help resolve gap or mark detection problems.
Test Labels	This option allows you to print test labels one at a time. Press <b>OK</b> to print the next label.
Dump Mode	This options enters Dump mode. For more information on Dump mode, see <a href="#">“Troubleshooting Communication Problems” on page 42</a> .
Factory Default	This option restores the factory default settings. Press <b>OK</b> to select this option and then follow the instructions on the screen.
Setup and Exit	This option exits Extended Test mode and puts the printer in Setup mode.
Exit	This option exits Extended Test mode.

**Changing Configuration Settings**

There are several ways you can change the configuration settings of the printer. You can change the configuration settings:

- from the display.
- from the host PC using PrintSet.
- from the host PC using the command line.
- from the printer home page.
- from the SmartSystems Console.

**Changing the Configuration Settings From the Display**

You need to enter Setup mode before you can change configuration settings. For more information on entering Setup mode and navigating through the settings, see [“Understanding Setup Mode” on page 17](#).

The top levels of the Setup menu are organized in a one-way loop. Each level has several sub-levels. When the printer starts up, the firmware determines the options available on the printer and adds this information to the Setup menu.

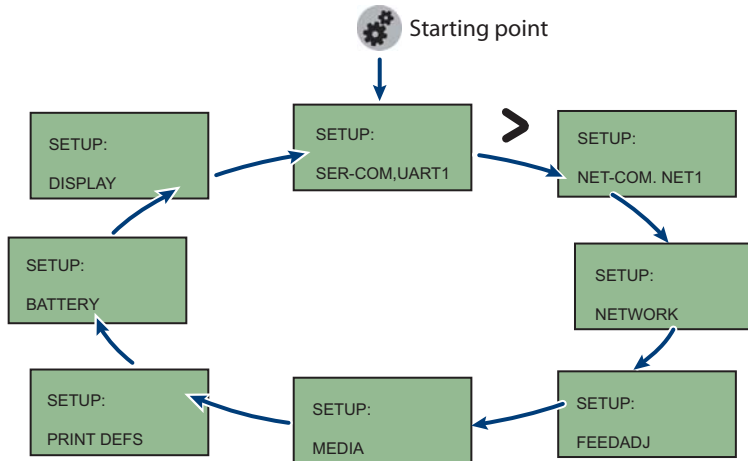

**The Main Levels of the Setup Menu in Fingerprint**

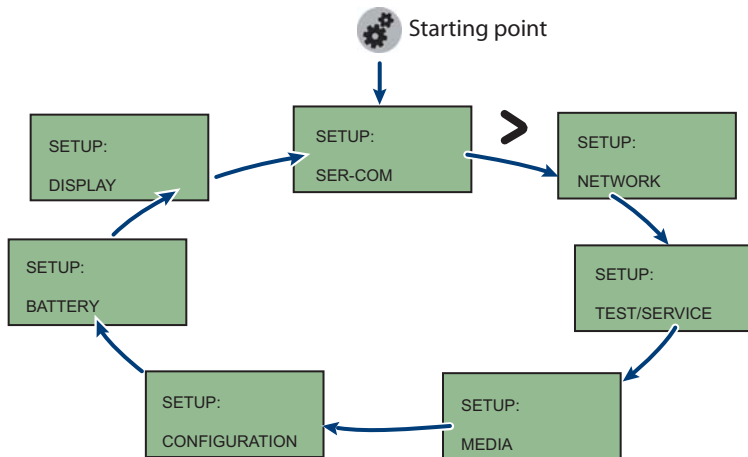

**The Main Levels of the Setup Menu in IPL**

### Changing the Configuration Settings from PrintSet

PrintSet Version 4.2 is a printer configuration tool that you can download from the Intermec web site. PrintSet can communicate with your printer through a serial cable or a network connection. It works on all PCs running Windows 98 (or later). PrintSet allows you to easily change all of the setup parameters. It also includes setup wizards to guide you through some common configuration tasks.

### Changing the Configuration Settings Using the Command Line

You can change configuration parameters by sending commands directly to the printer using your terminal program (Hyperterminal) and a serial or network connection.

If your printer uses the Fingerprint language, you use the SETUP command, followed by the node, subnode, and parameters setting. Here is a Fingerprint example that sets your media setting to labels with gaps:

```
SETUP "MEDIA,MEDIA TYPE,LABEL (w GAPS)"
```

If your printer uses the IPL language, you would send this command:

```
<STX><SI>T1<ETX>
```

Fingerprint automatically sends feedback to Hyperterminal as you type. If you want to see what you are typing with IPL, you need to complete the following procedure.

#### To see IPL commands as you type

- 1 From the Hyperterminal menu, select **File > Properties** > the **Settings** tab.
- 2 Click the **ASCII Setup** button.
- 3 Select **Echo typed characters locally**.
- 4 Click **OK** twice.

For more information on how to change configuration settings, see either the *Fingerprint Programmer's Reference Manual* (P/N 937-005-xxx) or the *IPL Programmer's Reference Manual* (P/N 066396). You can download both documents from the Intermec web site at [www.intermec.com](http://www.intermec.com).

### Changing Configuration Settings from the Printer Home Page

If you have an 802.11 radio in your PB50 printer and it is connected to the network, you can use your web browser to open the printer home page and make any desired configuration changes. To connect to a wireless network, follow the procedure in “Setting Up 802.11 Radio Communications” on page 26.



EasyCoder PB50	
Name (WINS):	INTERMEC000000
Firmware Version:	MCS 1863, 27-Sep-07 14:53:07
Active Command Set:	IPL 11.1.0
MAC Address:	00:1a:73:40:93:ef
IP Address:	10.20.111.166
Image buffer:	<a href="#">label.png</a>
RtW™:	Operational

#### The PB50 Printer Home Page

From the home page, click **Configuration** to make your changes.

### Changing Configuration Settings from SmartSystems Console

You can use the SmartSystems Console to change configuration settings on your printer. The PB50 ships with the SmartSystems client loaded on it. The console is part of SmartSystems Foundation and is available from the IntermeC web site. To download SmartSystems Foundation, go to [www.intermec.com/products/smrtsysfoundation/index.aspx](http://www.intermec.com/products/smrtsysfoundation/index.aspx).

## Establishing Communications With a Host

The PB50 must establish communications with a host that will send the data for the printer to print. The PB50 provides three ways to communicate with a host:

- Bluetooth radio communications
- 802.11 b/g radio communications
- Serial communications



## Setting Up Bluetooth Communications

The PB50 can contain a Bluetooth radio that allows wireless communications with a remote device from distances up to 100 meters (approximately 328 feet) depending on the Bluetooth range capabilities of the remote device, environmental conditions, and obstructions. For the Bluetooth-enabled devices to exchange data, both devices must establish a connection. Bluetooth software is always running in the background.

The PB50 cannot initiate a Bluetooth connection. One of the devices, such as a CK31, CK61, 700 series, CN2B, or CN3 mobile computer, must request a connection with the printer. The PB50 then accepts or rejects the connection. Use Intermec Settings on the mobile computer to enable the Bluetooth settings on the PB50.

The PB50 can also connect to Bluetooth scanners such as the SF51 and the SR61. You can create the bar code labels you need to connect the printer to a Bluetooth scanner using EasySet software. If you are going to create the bar code labels using EasySet, you will need to know the Bluetooth Device Address and the PIN of the PB50. You can download a free version of EasySet from the Intermec web site at [www.intermec.com](http://www.intermec.com).

Each PB50 equipped with a Bluetooth radio has a unique Bluetooth Device Address (BDA) loaded into its module when manufactured. You can find the BDA on the certification label located on the bottom of the printer.

### To set up Bluetooth communications with a mobile computer

- Follow the procedure to discover and connect to Bluetooth devices in your mobile computer user's manual.





**Note:** For maximum security, you need to configure a Bluetooth passcode for the PB50. The default passcode for the PB50 is “1234.”

### To set up Bluetooth communications with a scanner

- 1 Download and install EasySet.
- 2 Create the following bar code labels using EasySet:
  - Administrator reset factory defaults
  - Bluetooth parameters - security - not active

- Bluetooth parameters - connect/disconnect - compose BT address
  - Bluetooth parameters - security - compose PIN:
- 3 Scan the bar code labels with the Bluetooth scanner.
  - 4 *Will the printer blink in response??*

### Understanding Bluetooth Radio Icons

Icon	Description
	The Bluetooth radio is on and the printer is not connected to a serial cable.
	The Bluetooth radio is turned off. The Bluetooth radio turns off when you connect a serial cable.

## Setting Up 802.11 Radio Communications





The PB50 can have an internal 802.11 b/g radio to transfer and receive data using wireless communications. This manual assumes that you have already set up your wireless communications network including your access points. The following procedures include information on setting up wireless security for both IPL and Fingerprint versions of the PB50.

The PB50 supports these authentication modes: none, WEP, WPA Personal and Enterprise mode, WPA2 Personal and Enterprise mode (802.1x authentication).



WPA and WPA2 Enterprise mode currently support PEAP, TTLS, and LEAP. For LEAP authentication, EAP is not supported.

### Understanding 802.11 Radio Icons

Icon	Description
	Excellent signal
	Strong signal
	Good signal
	Poor signal

**Understanding 802.11 Radio Icons (continued)**

Icon	Description
	Very poor signal
	No Signal
	Radio is off

To set up the PB50 to work in your wireless network, you will need:

- Serial cable (P/N 075497-001)
- Host PC running Windows or Linux
- Serial port software such as Hyperterminal



**Note:** If you are using IPL commands with Hyperterminal, you may want to be able to see the commands as you type them on your screen. For help, see [“Changing the Configuration Settings Using the Command Line” on page 23.](#)

**To set up the PB50 for wireless communications**

- 1 Connect the 8-pin circular DIN connector to the serial port on the PB50.
- 2 Connect the other end of the serial cable to a serial port on the back of your PC or to a serial adapter on your mobile computer.
- 3 Open Hyperterminal on your PC and configure the following parameters for the serial port:

Parameter	Default Setting
Baud rate	115200
Data bits	8
Parity	None
Stop bits	1

- 4 From the host PC, check the wireless settings.

If you have an IPL version of the printer, send these commands to the PB50:

```
<STX><SI>wt,SSID<ETX>
<STX><SI>wt,WEP1<ETX>
<STX><SI>wt,WEP2<ETX>
<STX><SI>wt,WEP3<ETX>
<STX><SI>wt,WEP4<ETX>
<STX><SI>wt,AUTH<ETX>
<STX><SI>wt,WPA<ETX>
<STX><SI>wt,WPA2<ETX>
<STX><SI>wt,WPA_PSK<ETX>
<STX><SI>wt,ROAM<ETX>
<STX><SI>wt,PWR_MODE<ETX>
<STX><SI>wt,CHANNEL<ETX>
<STX><SI>wt,AP_MAC<ETX>
<STX><SI>wt,SIGNAL<ETX>
<STX><SI>wt,SPEED<ETX>
<STX><SI>wt,ACTIVE<ETX>
```

If you have a Fingerprint version of the printer, send this command to the PB50:

```
setup write "wlan","uart1:"
```

- 5 Set up the PB50 to use the correct SSID and authentication modes. See one of the following procedures to configure wireless printing on your IPL or Fingerprint printer.
- 6 If you are going to use certificates for validation, transfer the certificate to the printer. The printer can accept .pfx, .pem, and .der certificates.
- 7 Verify that the PB50 is connected to the access point and make sure it has an IP address allocated to it.

Use the following sections to set most of your wireless communication settings. For help with additional commands and information, see either the *Fingerprint Programmer's Reference Manual* (P/N 937-005-xxx) or the *IPL Programmer's Reference Manual* (P/N 066396). You can download both documents from the Intermec web site at [www.intermec.com](http://www.intermec.com).

## Configuring Wireless Printing Using IPL

Use the following procedures to configure your PB50 with IPL for wireless printing.

### To configure the printer to use WEP authentication

- 1 Send the following commands to login as an admin and set the SSID:

```
<STX><ESC>.s,su -p pass admin<ETX>  
<STX><SI>ws,SSID,xxxxx<ETX>
```

Where *xxxxx* can be from 0 to 32 alphanumeric characters.

- 2 Send the following commands to configure the WEP keys. The following example sets WEP key 1 to 1234 and enables WEP key 1.

```
<STX><SI>ws,WEP1,0x0001020304<ETX>  
<STX><SI>ws,.WEP_KEY,1<ETX>
```

- 3 Send the following command to activate the settings.

```
<STX><SI>ws,ACTIVE,1<ETX>
```

### To configure the printer to use WPA-PSK or WPA2-PSK mode

- 1 Send the following commands to login as an admin and set the SSID:

```
<STX><ESC>.s,su -p pass admin<ETX>  
<STX><SI>ws,SSID,xxxxx<ETX>
```

Where *xxxxx* can be from 0 to 32 alphanumeric characters.

- 2 Send the following commands to set up WPA-PSK or WPA2-PSK authentication:

```
<STX><SI>ws,WPA,ON<ETX>  
<STX><SI>ws,WPA2,ON<ETX>  
<STX><SI>ws,WPA_PSK,xxxxxxxxxxx<ETX>
```

Where *xxxxxxxxxxx* is a value between 8 and 64 characters.

- 3 Send the following command to activate the settings:

```
<STX><SI>ws,ACTIVE,1<ETX>
```

### To configure the PB50 to use WPA or WPA2 Enterprise mode

- 1 Send the following commands to login as an admin and set the SSID:

```
<STX><ESC>.s,su -p pass admin<ETX>  
<STX><SI>ws,SSID,xxxxx<ETX>
```

Where *xxxxx* can be from 0 to 32 alphanumeric characters.

- 2 Send the following commands to enable WPA-802.1x or WPA2-802.1x authentication:

```
<STX><SI>ws , WPA , ON<ETX>  
<STX><SI>ws , WPA2 , ON<ETX>  
<STX><SI>ws , WPA_PSK , <ETX>
```

- 3 Send these commands to configure the EAP\_TYPE:

```
<STX><SI>ws , EAP_TYPE , xxxxx<ETX>
```

Where *xxxxx* can be OFF, LEAP, PEAP, or TTLS.

```
<STX><SI>ws , .EAP_USER , xxxxx<ETX>  
<STX><SI>ws , .EAP_PASS , xxxxx<ETX>
```

Where *xxxxx* can be an alphanumeric value up to *???* characters.

- 4 If you are using TTLS, you may need to send this command to set the TTLS outer name:

```
<STX><SI>ws , TTLS_USER , xxxxx <ETX>
```

Where *xxxxx* can be an alphanumeric value up to *???* characters.

- 5 If you are using certificates for validation, here are some commands you may need to use.

- Send the following commands to set a certificate and enable validation:

```
<STX><SI>ws , CA_CERT , c:/testCA.pfx@export<ETX>  
<STX><SI>ws , VALIDATE , ON<ETX>
```

Where *c:/testCA.pfx* is the location and name of the certificate and *export* is the passphrase.

- Send the following commands to set a common name for server 1 and server 2:

```
<STX><SI>ws , .SERVER_CN1 , xxxxxxxxxxxx <ETX>  
<STX><SI>ws , .SERVER_CN2 , xxxxxxxxxxxx <ETX>
```

Where *xxxxxxxxxx* can be a value from 0 to 64 characters.

- Send the following command to make sure your values match those used by the access point:

```
<STX><SI>wt , [variable name]<ETX>
```

All variables are returned with the exception of EAP\_PASS which always returns “\*\*\*\*” if configured and CA\_CERT which transmits the name of the last certificate authority successfully installed. An additional read-only variable for the supplicant state, called STATE, is also returned.

- You may need to send the following command several times for the wireless station to connect:

```
<STX><SI>ws,ACTIVE,1<ETX>
```

### Configuring Wireless Printing Using Fingerprint

Use the following procedures to configure your PB50 with Fingerprint for wireless printing.

#### To configure the printer to use WEP authentication

- 1 Send the following commands to login as an admin and set the SSID:

```
run"su-p pass admin"  
setup write "wlan","uart1:"  
setup "wlan","SSID","xxxxx"
```

Where *xxxxx* can be from 0 to 32 alphanumeric characters.

- 2 Send the following commands to configure the WEP keys. The following example sets WEP key 1 to 1234 and enables WEP key 1.

```
setup "wlan","WEP1","0x0001020304"  
setup "wlan",".WEP_KEY","1"  
setup "wlan","ACTIVE","1"  
setup write "wlan","uart1:"
```

#### To configure the printer to use WPA-PSK or WPA2-PSK mode

- 1 Send the following commands to login as an admin and set the SSID:

```
run"su-p pass admin"  
setup write "wlan","uart1:"  
setup "wlan","SSID","xxxxx"
```

Where *xxxxx* can be from 0 to 32 alphanumeric characters.

- 2 Send the following commands to set up WPA-PSK or WPA2-PSK authentication:

```
setup "wlan","WPA","ON"  
setup "wlan","WPA2","ON"  
setup "wlan","WPA_PSK","xxxxxxxxxxxxx"
```

```
setup "wlan", "ACTIVE", "1"  
setup write "wlan", "uart1:"
```

Where `xxxxxxxx` is a value between 8 and 64 characters.

### To configure the PB50 to use WPA or WPA2 Enterprise mode

- 1 Send the following commands to login as an admin and set the SSID:

```
run"su-p pass admin"  
setup write "wlan", "uart1:"  
setup "wlan", "SSID", "xxxxx"
```

Where `xxxxx` can be from 0 to 32 alphanumeric characters.

- 2 Send the following commands to set up WPA-802.1x or WPA2-802.1x authentication:

```
setup "wlan", "WPA", "ON"  
setup "wlan", "WPA2", "ON"  
setup "wlan", "WPA_PSK", ""  
setup write "wlan", "uart1:"
```

- To view the 802.1x values, send this command:

```
setup write "8021x", "uart1:"
```

- 3 Send these commands to configure the EAP\_TYPE:

```
setup "8021x", "EAP_TYPE", "xxxx"
```

Where `xxxx` can be OFF, LEAP, PEAP, or TTLS.

```
setup "8021x", ".EAP_USER", "xxxx"  
setup "8021x", "EAP_PASS", "xxxx"
```

Where `xxxx` can be an alphanumeric value up to ?? characters.

- 4 If you are using TTLS, you may need to send this command to set the TTLS outer name:

```
setup "8021x", "TTLS_USER", "xxxx"
```

Where `xxxx` can be an alphanumeric value up to ??? characters.

- 5 If you are using certificates for validation, here are some commands you may need to use.

- Send the following commands to set a certificate and enable validation:

```
setup "8021x", "CA_CERT", "c:/test.pfx@export"  
setup "8021x", "VALIDATE", "ON"
```



Where *c:/test.pfx* is the location and name of the certificate and *export* is the passphrase.

- Send the following commands to set a common name for server 1 and server 2:

```
setup "8021x", ".SERVER_CN1", xxxxxxxxxxxx <ETX>  
setup "8021x", ".SERVER_CN2", xxxxxxxxxxxx <ETX>
```

Where xxxxxxxxxxxx can be a value from 0 to 64 characters.

- Send the following command to make sure your values match those used by the access point:

```
setup write "8021x", "uart1:"
```

- You may need to send the following command several times for the wireless station to connect:

```
setup "wlan", "ACTIVE", "1"<ETX>
```

## Setting Up Serial Communications

You can use a serial cable (P/N 075497-001) to connect the PB50 to a PC or a mobile computer. For the mobile computer, you may need to purchase a serial adapter. For more information, contact your local Intermec sales representative.

Before you can establish a serial connection, you need to make sure that the settings on the PC or mobile computer match those of the PB50.

### Serial Port Settings on the PB50

Parameter	Default Setting
Baud rate	115200
Data bits	8
Parity	None
Stop bits	1
Flow control	XON_XOFF

### To connect the PB50 to a PC or mobile computer

- 1 Connect the 8-pin circular DIN connector to the serial port on the PB50.

- 2 Connect the other end of the serial cable to a serial port on the back of your PC or to a serial adapter on your mobile computer.

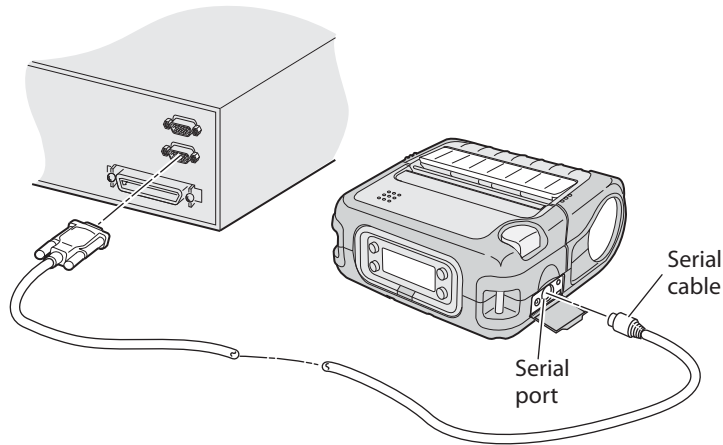

**Connecting the PB50 to the Serial Port of a PC**

## Upgrading the Firmware

The latest firmware and software is always available for download from the Intermec web site at [www.intermec.com](http://www.intermec.com).

### To download firmware updates

- 1 Go to the Intermec web site at [www.intermec.com](http://www.intermec.com).
- 2 Click **Support > Downloads**.
- 3 In the **Select a Product** field, choose PB50 portable printer. The latest available software displays on the page.
- 4 Download the latest firmware version to your computer. Make sure you choose the correct firmware upgrade for your IPL or Fingerprint printer.
- 5 Extract the .zip file to a folder on your computer.

You have options for upgrading the firmware based on whether your PB50 has a Bluetooth radio or an 802.11 b/g radio. Use one of the following procedures to upgrade your printer firmware. Your printer should reboot after you finish upgrading the firmware. If it does not reboot, you will need to cold boot the printer. For help, see “**Cold Booting the PB50**” on page 43.

### To upgrade your printer using PrintSet

- 1 Download the latest version of PrintSet from the Intermec web site at [www.intermec.com](http://www.intermec.com).
- 2 Select **File > Add Printer** to start the Add Printer Wizard which guides you through the process of adding your printer.
- 3 Select your printer under My Printers and then go to **Printer > Firmware Wizard**.

The Firmware Wizard guides you through the necessary steps to update your firmware.

### To upgrade your printer using an 802.11 network connection

- 1 Browse to the home page of the printer. For help, see “[Changing Configuration Settings from the Printer Home Page](#)” on page 24.
- 2 From the home page, click **Maintenance**.
- 3 From the Firmware upgrade page, browse to the upgrade firmware file.
- 4 Click **Upgrade**.

### To upgrade your printer using a serial connection

- 1 *Add Rod's procedure here...????*

## Downloading Fonts and Graphics

The easiest way to download fonts and graphics is to use the free Intermec printer application called PrintSet. You can download PrintSet from the downloads page for the PB50 printer on the Intermec web site at [www.intermec.com](http://www.intermec.com).

Follow the procedures in the PrintSet online help to download fonts and graphics.





# **3 Troubleshooting and Maintaining the PB50**

## Troubleshooting the PB50

You may have printer operation, print quality, or printer communication problems at some time during the life of the PB50 printer. It is easy to fix most of the problems and you will find solutions in the “Printer Problems and Solutions” section of this chapter. If you cannot find the answer to your problem, you may need to contact Product Support.

### Contacting Product Support

Before you call Intermec Product Support, you may want to visit the Intermec technical knowledge base (Knowledge Central) at [intermec.custhelp.com](http://intermec.custhelp.com) to review technical information or to request technical support. If you still need help after visiting Knowledge Central, you may need to call Product Support.

To talk to an Intermec Product Support representative in the U.S.A. or Canada, call:

**1-800-755-5505**

Outside the U.S.A. and Canada, go to [www.intermec.com](http://www.intermec.com) and click **Contact** to find your local Intermec representative.

Before you call Intermec Product Support, make sure you have the following information ready:









- Printer serial number
- Firmware type and version
- Bluetooth, wireless, or serial port settings

You can find all of the information listed above in the printer menu system or on a test print page.

### Understanding Error Messages

Use the following tables to troubleshoot some common error message you may see display on PB50 screen. Some of the error messages are specific to the type of firmware you have loaded on your PB50.

**Possible PB50 Error Icons and Messages**

Error Icon	Error Message	Description
	Pause	The printer is paused.
	Paper out	The printer is out of paper. Load a new roll of media. For help, see <a href="#">“Loading Media” on page 9</a> .
	Test feed not done	The printer did not perform a test feed before it printed out test labels. It is important to perform a test feed because it calibrates the sensor. Press the <b>Feed</b> button to perform a test feed.
	Printhead hot	The printhead is overheated and needs to cool down. Wait for printing to resume automatically.
	Upgrading	The printer is loading new firmware.
	LSS too high, LSS too low	These errors can occur when you run a test feed without any media installed, or if you have incorrect media settings.  Load the printer with media (see <a href="#">“Loading Media” on page 9</a> ), run Test mode (see <a href="#">“Using Test Mode” on page 19</a> ), and select the appropriate media type.
	IP configuration error	The printer is trying to acquire an IP address from the network. Wait for the printer to complete the task before taking any action.
	IP link error	????
	Field out of label	You are attempting to print in an area that extends beyond the print window. See the programmer’s reference manual for your type of firmware (IPL or Fingerprint) for information on how to set the media parameters.

## Troubleshooting Printer Problems and Finding Solutions

Use the following tables to troubleshoot some common problems you may encounter with the PB50 printer.

### **Printer Problems and Solutions**

<b>Problem</b>	<b>Possible Solution</b>
The printer does not turn on when you press <b>Standby</b> .	<ul style="list-style-type: none"><li>• Replace the battery with a charged battery.</li><li>• Connect external power to make sure the printer works correctly and to charge the battery.</li></ul>
The blue light is blinking.	<ul style="list-style-type: none"><li>• Make sure media is loaded and the media cover is closed. For help, see <a href="#">“Loading Media” on page 9</a>.</li><li>• There is a printing error. The screen displays an error message containing information on the error.</li><li>• The printer is paused. The printer is cancelling a print job.</li><li>• The printer is in Setup mode. Press <b>Setup</b> to exit Setup mode.</li></ul>
The printer is not printing with a Bluetooth connection.	<ul style="list-style-type: none"><li>• Re-establish a Bluetooth connection with the mobile computer or scanner. For help, see your mobile computer user’s manual or <a href="#">“Setting Up Bluetooth Communications” on page 25</a>.</li><li>• Make sure the mobile computer can print to a known good printer.</li><li>• Print a Bluetooth test print page to make sure that the mobile printer discovered your printer. For help, see <a href="#">“Printing a Test Page” on page 13</a>.</li><li>• Make sure the printer is in Ready mode.</li></ul>
The printer is not printing with an 802.11 wireless connection.	<ul style="list-style-type: none"><li>• Check your wireless settings??</li><li>•</li></ul>



**Printer Problems and Solutions (continued)**

Problem	Possible Solution
When printing, the printer is skipping labels.	<ul style="list-style-type: none"> <li>• Go into Test mode and run a test feed. For help, see <a href="#">“Using Test Mode” on page 19</a>.</li> <li>• Make sure the label gap sensor is clean. For help, see <a href="#">“Cleaning the Printer” on page 44</a>.</li> </ul>
Printer keeps printing or feeding when it should stop.	<ul style="list-style-type: none"> <li>• Check media settings.</li> <li>• Make sure the label gap sensor is clean. For help, see <a href="#">“Cleaning the Printer” on page 44</a>.</li> </ul>
Printout is faded or weak.	<ul style="list-style-type: none"> <li>• Fingerprint users: adjust the media constant, factor, and contrast.</li> <li>• IPL users: adjust the media sensitivity setting.</li> <li>• Check to see if the printhead needs cleaning. For help, see <a href="#">“Cleaning the Printer” on page 44</a>.</li> </ul>
The battery charge is not lasting as long as it should.	<ul style="list-style-type: none"> <li>• Check the battery date. If the battery is a few years old, the shortened life may be due to normal aging.</li> <li>• Replace the battery.</li> </ul>
The test pages do not print.	<ul style="list-style-type: none"> <li>• Make sure that the blue light is not blinking. If it is, make sure your printer has media and that the media cover is closed.</li> <li>• Make sure that you can advance media by pressing the <b>Feed</b> button.</li> </ul>
Print quality is poor.	<ul style="list-style-type: none"> <li>• Clean the printhead. For help, see <a href="#">“Cleaning the Printer” on page 44</a>.</li> <li>• Check the battery and recharge or replace as necessary. For help, see <a href="#">“Charging the Batteries” on page 7</a>.</li> <li>• Check the quality of the media. Use only Intermec media to ensure superior print quality and product performance.</li> </ul>
The printout is not in the desired position.	<ul style="list-style-type: none"> <li>• Check for errors in the software application.</li> <li>• Make sure the label gap sensor and platen roller are clean.</li> </ul>

## Troubleshooting Communication Problems

Use Dump mode to verify that the printer is receiving data from the host correctly.

### Using the Line Analyzer in Fingerprint

In Dump mode, the printer runs a Fingerprint program called Line Analyzer. The Line Analyzer captures incoming characters on the communication ports and prints them on one or more labels.

The easiest way to enter Dump mode is through Test mode or Extended Test mode. For help, see [“Understanding Test Mode” on page 19](#).

After the printer enters Dump mode, it tells you it has entered Dump mode by printing it on a label. The display shows the Dump mode icon and printer is ready to receive data.

While the printer is receiving data, the Ready-to-Work indicator blinks (true??) After a half of a second, if no more characters have been received, the printer times out. The program considers the transmission terminated and prints out a label.

Printable characters are printed in black-on-white. Control characters and space characters (ASCII 000 to 032 dec) are printed in white-on-black.

As long as a continuous string of characters is being received, the program wraps the lines until the label is full and then starts to print another label. After each character transmission, the following information prints:

- Page number
- Number of characters printed on the label
- Total number of characters received so far

When you exit Dump mode, a final label prints to inform you that it is exiting from Dump mode.

### Using Dump Mode in IPL

When you enter Dump mode, the printer captures incoming characters on the communication ports and prints them on one or more labels.

If you have IPL firmware on your printer, you can access Dump mode in two different ways with slightly different results:

- You can access Dump mode through Test mode or Extended Test mode and you will receive printouts that look exactly like those produced with the Line Analyzer program in Fingerprint. For more information, see the previous procedure, “[Using the Line Analyzer in Fingerprint](#)” on [page 42](#).
- You can access Dump mode from the Setup menu. If you access Dump mode this way, characters are printed on a continuous line along with corresponding hexadecimal numbers.

**To enter Dump mode from the Setup menu**

- 1 Press the **Setup** button.
- 2 Press **▶** until you reach **Test/Service**.
- 3 Press **OK** to enter the Test/Service menu.
- 4 Press **▶** until you reach **Data Dump** and then press **OK**.
- 5 Press **▶** to select Yes and then press **OK**.
- 6 Cold boot the printer to exit Dump mode. For help, see the next procedure, “Cold Booting the PB50.”

## **Cold Booting the PB50**

You rarely need to cold boot the PB50 printer, unless you are upgrading the firmware. If your printer occasionally locks up, you will want to cold boot it.



**Note:** The Setup menu is not affected by a cold boot. Your printer retains all of your configuration settings after the printer powers back up.

**To reset the PB50**

- 1 Disconnect the PB50 from power if externally powered.
- 2 Remove the battery from the PB50 for at least one second.
- 3 Insert the battery back into the PB50.
- 4 Reconnect external power if your PB50 is externally powered.

A cold boot reinitializes the 802.11 radio and clears the working memory.

## Cleaning the Printer

To properly maintain your PB50, you should clean it at the recommended intervals.



Warning

**To avoid possible personal injury or damage to the printer, never insert any pointed or sharp objects into the printer.**



Caution

**Use only the cleaning agents specified in this section. Intermec is not responsible for damage caused by any other cleaning materials used on this printer. Clean the printer with a cotton swab saturated with alcohol.**

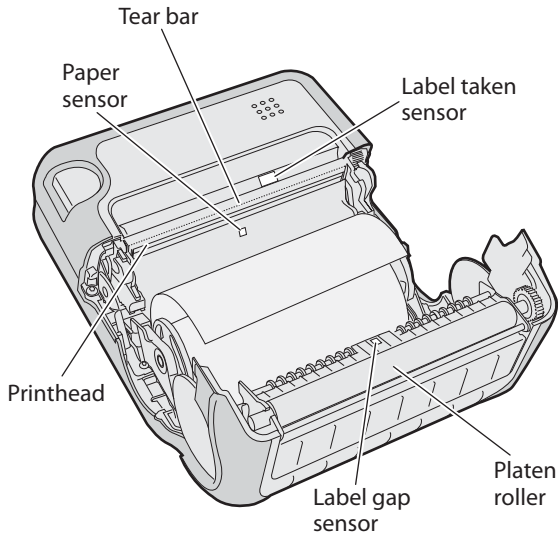

**PB50 Portable Label Printer:** Identifying the parts of the PB50 to clean regularly.

#### ***Cleaning the PB50 Printer***

<b>Printer Part</b>	<b>Cleaning Method</b>	<b>Cleaning Interval</b>
Printhead	Use 70% isopropyl alcohol on a cotton swab to clean the print elements from end to end.	After every five rolls of media or more often if necessary.
Platen roller	Rotate the platen roller and clean it thoroughly with 70% isopropyl alcohol on a cotton swab.	After every five rolls of media or more often if necessary.
Paper sensors	Clean thoroughly with 70% isopropyl alcohol and a cotton swab.	After every five rolls of media or more often if necessary.
Tear bar	Clean thoroughly with 70% isopropyl alcohol and a cotton swab.	As needed.
Exterior	Clean with a water-dampened cloth.	As needed.
Interior	Brush or air blow. Make sure the paper sensor is free of dust.	After every five rolls of media or more often if necessary.



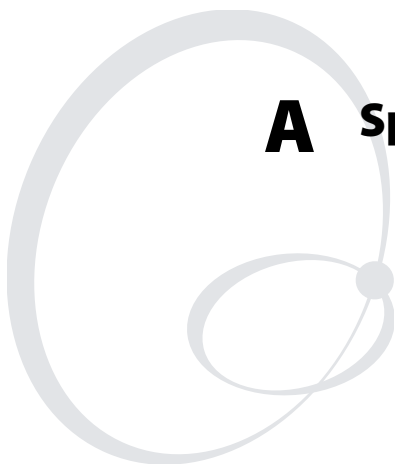

# **A Specifications**

# Specifications

## Physical Dimensions

Depth	78.7 mm (3.1 in)
Height	174.5 mm (6.9 in)
Width	159.5 mm (6.3 in)
Weight	1190 g (2 lb)

## Power Specifications

AC power adapter voltage	100 to 240V
Printer voltage	100V to 240V and 50 Hz to 60 Hz
Operating power	Rechargeable 16.8 V 2200 mAh lithium-ion battery

## Temperature and Humidity Specifications

Operating temperature	-15°C to 50°C (5°F to 122°F)
Non-operating temperature	0°C to 45°C (32°F to 113°F)???
Relative humidity	0 to 95% non-condensing

## Media Specifications

Core inside diameter, standard	19 mm (0.75in)
Core inside diameter, with adapter	10.2 mm (0.4 in)
Maximum roll outside diameter	67.3 mm (2.65 in)
Media width, label with liner/receipt	49mm (1.9 in) to 111.5 mm (4.4 in)
Media length, label	25.4 mm (1.0 in) to 609.6 mm (24 in)
Media length, receipt	Continuous
Media caliper, label with liner/receipt	0.05 mm (0.002 in) to 0.165 mm (0.0065 in)
Media caliper, tag	0.15 mm (0.006 in)
Gap length (centered on perforation)	3.17 mm (0.125 in) to 12.7 mm (0.50 in)
Notch length (centered on perforation)	6.35 mm (0.25 in)
Notch width (centered on perforation)	12.7 mm (0.50 in)
Black mark length (centered on perforation)	3.17 mm (0.125 in) to 12.7 mm (0.50 in)
Black mark width (centered on media width)	12.7 mm (0.50 in) to full width of media



Receipt roll stock media is supplied as a continuous roll. Label, tag, and fanfold media use repeat indicators for non-continuous media. Gap, notch, and black marks are used as repeat indicators:

- **Gap:** Label and fanfold media
- **Notch:** Tag media
- **Black mark:** Label, tag, and fanfold media

Here are a few things to keep in mind when ordering media for the PB50 printer:

- Black marks can be sensed on either side of the media.
- You can use higher caliper media in the printer, but print quality will be reduced.
- Receipt roll stock media has an end of roll indicator. The end of roll indicator is a red marking (on last 3 feet of roll) on the thermally sensitive side of the paper.

#### **External Fanfold Media Specifications**

Stack height	70 mm (2.75 in)
Page length	152 mm (6 in) to 305 mm (12 in)



**Note:** The stack height is for a 6-inch page length supplied in 12-inch stacks (two 6-inch stacks of equal height with the bottom page linked).

Specialty media is required for unique customer environments, including printer operating temperature extremes. Intermec recommends that you test the media in your application.

#### **Supported Media**

The PB50 printer supports direct thermal label, tag, and receipt media. Both North American and European label media are supported in multiple label lengths. Receipt media is supported in both a top coated and an uncoated paper in continuous roll stock only.

The default media sensitivity number is: 180.

Use the following table as a guide when setting sensitivity numbers.

<b>Sensitivity</b>	<b>Media Description</b>
180	Duratherm II Label
180	Duratherm III Label
101	Duratherm 2.3 mil Uncoated Receipt
401	Duratherm 3.3 mil Coated Receipt
720	Duratherm Lightning Plus
150	Duratherm II 5 mil Tag
180	Duratherm Near IR
430	Duratherm Synthetic
450	Duratherm Lightning IR
470	Duratherm Lightning
103	Linerless
102	Duratherm 2.3 mil Uncoated Receipt
440	Thermal Eco
140	Thermal Topcoated

## Accessories for the PB50

You can use these accessories (sold and ordered separately) with the PB50 printer. To order accessories, contact your local Intermec sales representative.

### **AB13 Battery**

Use the lithium-ion 2200 mAh battery to provide power to the printer.

### **AC18 4-Bay Battery Charger**

Use the AC18 to charge up to four batteries at a time. The battery charger is designed to sense when a battery is fully charged and not overcharge it, ensuring long and consistent battery life.

### **AV8 Vehicle Dock**

Use the vehicle dock to attach the PB50 to a truck.

### **Belt Clip (**

Use the PB50 belt clip to attach the printer to your belt.

**Handstrap**

Use the PB42 and PB50 handstrap to conveniently carry your PB50 printer. With the handstrap attached, you can also attach the shoulder strap.

**Power Supply (Model AE19)**

Provides power to the PB50 and the 4-bay battery charger (Model AC18).

**Serial Cable**

The serial adapter is an 8-pin DIN to DB9 connector that connects from the PB50 printer to your desktop PC.

**Shoulder Strap**

Use the shoulder strap in combination with the handstrap to easily carry the PB50 printer. The wide padded strap makes it comfortable to wear the printer for long periods of time.



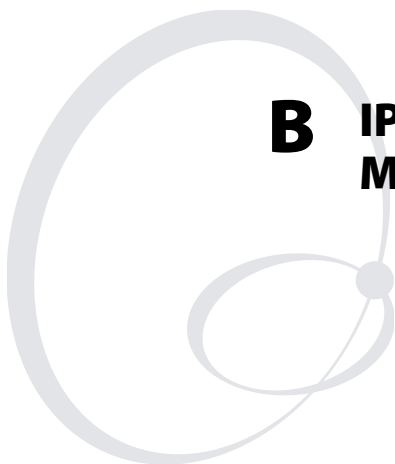

## **B** IPL and Fingerprint Setup Menus

# IPL Setup Menu

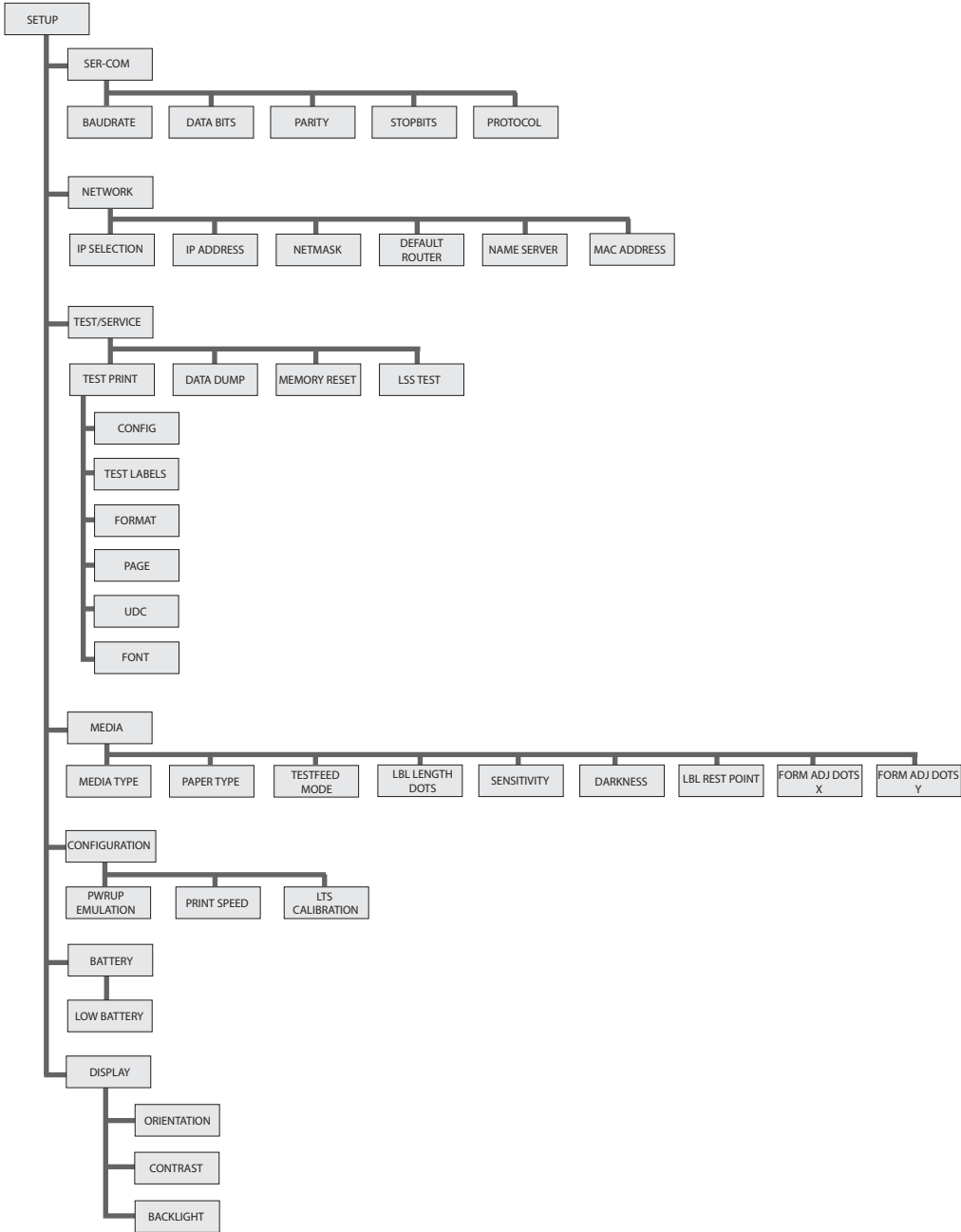

# Fingerprint Setup Menu

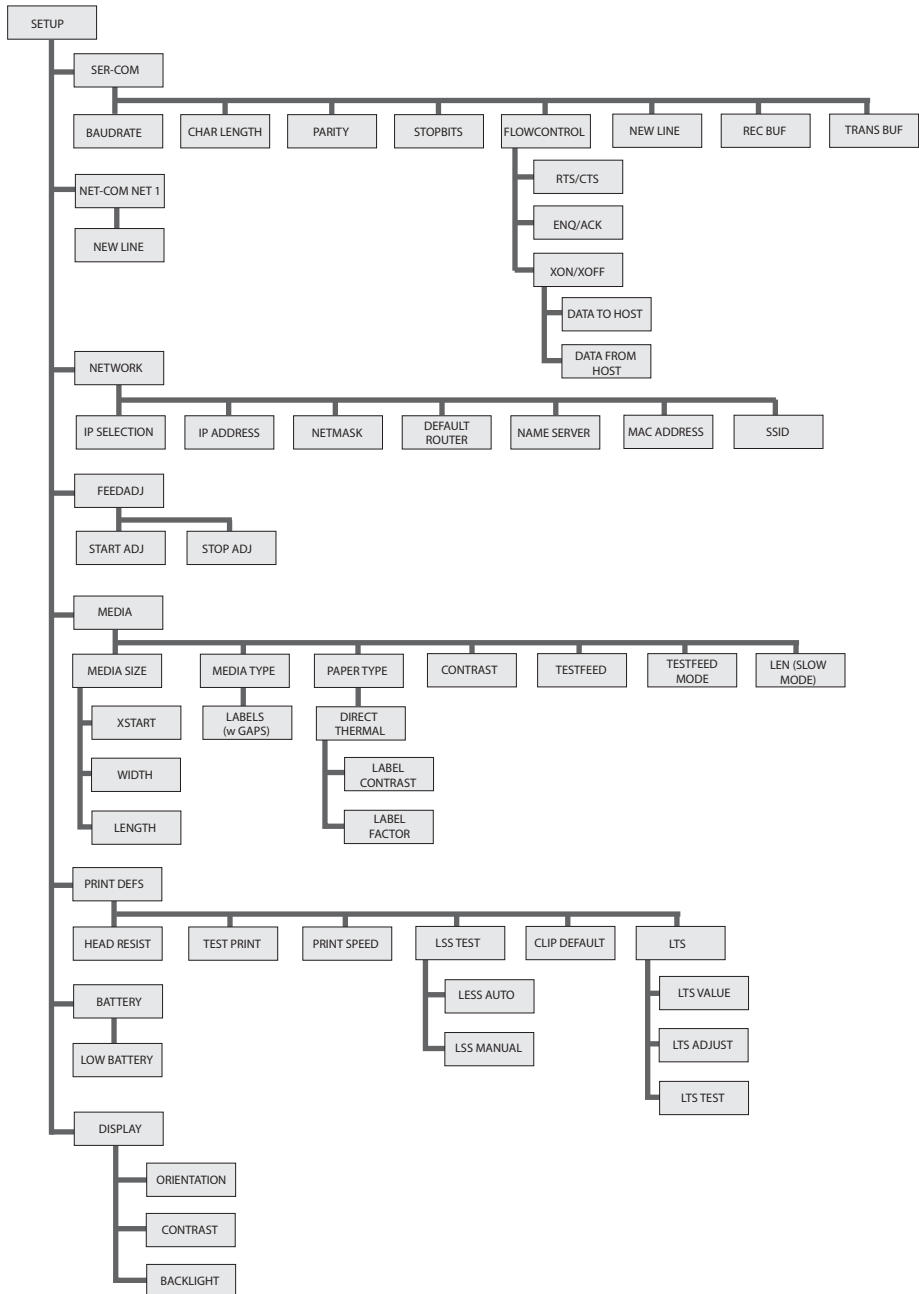







**Worldwide Headquarters**  
6001 36th Avenue West  
Everett, Washington 98203  
U.S.A.

**tel** 425.348.2600

**fax** 425.355.9551

[www.intermec.com](http://www.intermec.com)

PB50 Portable Label Printer User's Guide



P/N 934-012-001

# Important WUBB-151GB Radio Information!

**Note:** You need to read this information only if your Intermec product contains the WUBB-151GB 802.11b/g radio.

## For Users in the United States and Canada

This device complies with Part 15 of the FCC rules and with RSS-210 of Industry Canada. Operation is subject to the following two conditions: (1) This device may not cause harmful interference, and (2) This device must accept any interference received, including interference that can cause undesired operation.



Caution

**Changes or modifications not expressly approved by Intermec could void the user's authority to operate this equipment.**

## For Users Outside of the United States and Canada

Intermec Technologies Corporation declares that this module is in compliance with the essential requirements and other relevant provisions of R&TTE Directive (1999/5/EC).

The transmitter module's output power is ??? mW or less. The products using this module are intended for business and industrial environments. They should not be used in residential environments and by children.

**CE 0560** ⓘ This product is marked with this logo and uses radio frequency bands that are not harmonized throughout the European Community.

The following table indicates the areas of intended use of the equipment and any known restrictions.

Country of Intended Use	Yes	No	License Required	Restrictions	Details
Austria	X				
Belgium	X				
Cyprus	X				
Czech Republic	X				
Denmark	X				
Estonia	X				
Finland	X				
France	X			X	Outdoor frequency operation restricted to 10 mW in 2454 to 2483.5 MHz band.
Germany	X				
Greece	X				
Hungary	X				
Ireland	X				
Italy	X				
Latvia	X				
Lithuania	X				
Luxembourg	X				
Malta	X				
The Netherlands	X				
Poland	X				
Portugal	X				
Slovakia	X				
Slovenia	X				
Spain	X				
Sweden	X				

Country of Intended Use	License		Restrictions	Details
	Yes	No		
United Kingdom	X			
Other non-EU:				
Iceland	X			
Liechtenstein	X			
Norway	X			
Switzerland	X			

### 美国和加拿大以外的用户请注意：

Intermec Technologies Corporation 声明，此模块符合 R&TTE 指令 (1999/5/EC) 的基本要求和其它相关规定。

发射模块的输出功率为 100mW 或以下。使用此模块的产品计划用于商业和工业环境。不能在住宅环境中或由儿童使用。

**CE 0560** ⓘ 本产品上标有此徽标，并在整个欧盟范围内使用不同的无线电频段。

下表列出了计划使用该设备的地区以及任何已知限制。

计划使用该设备的国家	是	否	需要的许可证	限制	详细信息
法国		X		X	户外频率操作限制在 2446.5 MHz 到 2483.5 MHz 之间

### Pour les utilisateurs en dehors du Canada et des Etats-unis

Intermec Technologies Corporation déclare que ce module est conforme aux exigences de base et autres exigences pertinentes de la Directive R&TTE (1999/5/EC).

La puissance de sortie du module émetteur-récepteur est de 100 mW ou moins. Les produits utilisant ce module sont destinés à des environnements commerciaux et industriels. Ils ne doivent pas être utilisés dans des environnements résidentiels et par des enfants.

**CE 0560** ⓘ Ce produit porte ce logo et utilise des bandes RF qui ne sont pas harmonisées à travers l'Union Européenne.

Le tableau suivant répertorie les zones d'utilisation prévues pour l'équipement et les restrictions connues.

Pays d'utilisation prévu	License		Restrictions	Détails
	Oui	Non		
France	X		X	L'opération extérieure de fréquence est limitée à une valeur variant entre 2 446,5 MHz et 2 483,5 MHz.

### Für Benutzer außerhalb der USA und Kanada

Intermec Technologies Corporation erklärt hiermit, dass dieses Modul die wesentlichen Anforderungen und anderen relevanten Bestimmungen der R&TTE-Direktive (1999/5/EC) erfüllt.

Die Ausgangsleistung des Sendermoduls beträgt maximal 100 mW. Die Produkte, in denen dieses Modul verwendet wird, sind für gewerbliche und industrielle Umgebungen vorgesehen. Sie dürfen nicht in Wohngebieten und nicht von Kindern benutzt werden.

**CE 0560** ⓘ Dieses Produkt wird mit diesem Logo vertrieben und verwendet Funkfrequenzbänder, die in der Europäischen Gemeinschaft nicht harmonisiert sind.

Die folgende Tabelle führt die vorgesehenen Einsatzbereiche der Ausrüstung sowie bekannte Einschränkungen an.

Vorgesehen zur Verwendung in diesem Land	Ja	Nein	Lizenz obligatorisch	Einschränkungen	Einzelheiten
Frankreich	X			X	Frequenzbereich für Verwendung im Freien eingeschränkt auf 2446,5 MHz bis 2483,5 MHz.

### 미국 및 캐나다 이외의 거주자의 경우

Intermec Technologies Corporation 은 이 모듈이 R&TTE Directive (1999/5/EC) 필수 조건 및 기타 관련 규정을 준수함을 보증합니다.

송신기 모듈의 출력 전력은 100mW 이하입니다. 이 모듈을 사용하는 제품은 업무 및 산업용으로 설계되었습니다. 이 제품을 가정용으로 사용하거나 어린이가 사용해서는 절대 안됩니다.

**CE 0560** 이 제품에는 이 로고가 부착되어 있으며 고주파 대역을 사용하므로 EU (유럽 공동체)의 경우 사용이 적합하지 않습니다.

아래 표에 이 장비의 용도 및 알려진 규정 사항이 표시되어 있습니다.

장비 사용 국가	예	아니오	필요 라이선스	규정 사항	상세 정보
프랑스	X			X	외부에서 사용 시 주파수 범위는 2446.5MHz 에서 2483.5MHz 사이로 사용이 제한되어 있습니다.

### Para usuários que residem fora dos Estados Unidos e do Canadá

A Intermec Technologies Corporation declara que este módulo está em conformidade com os requisitos essenciais e outras disposições relevantes da Diretiva R&TTE (1999/5/EC).

A potência produzida pelo módulo transmissor é de 100 mW ou menos. Os produtos que usam este módulo foram projetados para ambientes comerciais e industriais e não devem ser usados em ambientes residenciais, nem por crianças.

**CE 0560** Este produto é identificado por este logotipo e usa faixas de radiofrequência não harmonizadas em toda a Comunidade Europeia.

A tabela a seguir identifica as áreas às quais o equipamento destina-se para uso e todas as restrições conhecidas.

País destinado para uso	Sim	Não	Licença requerida	Restrições	Detalhes
França	X			X	Frequência de operação ao ar livre restrita à faixa de 2446,5 MHz a 2483,5 MHz.

### Для пользователей вне Соединенных Штатов или Канады

Intermec Technologies Corporation заявляет, что данный модуль отвечает основным требованиям и другим существенным положениям директивы R&TTE (1999/5/EC).

Выходная мощность передатчика не превышает 100 мВт. Продукты, в которых используется этот модуль, предназначены для условий бизнеса и промышленных условий. Они не должны использоваться в жилых районах и не предназначаются для детей.

**CE 0560** Этот продукт маркирован данным логотипом и использует диапазоны радиочастот, не гармонизированные на территории Европейского Сообщества.

В следующей таблице приведены области предполагаемого применения оборудования и все известные ограничения.

Страна предполагаемого использования	Да	Нет	Требуется лицензия	Ограничения	Подробности
Франция	X			X	Работа вне помещений ограничена диапазоном частот 2446,5 МГц – 2483,5 МГц.

## Para usuarios fuera de los Estados Unidos y Canadá

Intermec Technologies Corporation declara que este módulo está conforme a los requisitos esenciales y otras disposiciones pertinentes de la Directriz R&TTE (1999/5/EC).

La potencia de salida del módulo transmisor es de 100mW o menor. Los productos que usan este módulo están destinados a entornos comerciales e industriales. No deben utilizarse en entornos residenciales ni quedar en manos de niños.

**CE 0560** Este producto está marcado con este logotipo y utiliza bandas de radiofrecuencia no armonizadas en toda la Comunidad Europea.

La tabla siguiente indica las áreas de uso a las cuales se destina el equipo y toda restricción conocida.

País donde se intenta usar	Si	No	Se requiere licencia	Restricciones	Detalles
Francia	X			X	La operación de frecuencias en exteriores está restringida entre 2446.5 MHz y 2483.5 MHz.



**Worldwide Headquarters**  
6001 36th Avenue West  
Everett, Washington 98203  
U.S.A.

**tel** 425.348.2600

**fax** 425.355.9551

[www.intermec.com](http://www.intermec.com)

© 2006 Intermec Technologies Corporation. All rights reserved.

Important WUBB-151 GB Radio Information!



P/N 933-110-001

# PB50 Compliance Insert



## For Users in the United States and Canada



**Caution:** This marking indicates that the user should read all included documentation before use.

**Attention:** Ce marquage indique que l'utilisateur doit, avant l'utilisation, lire toute la documentation incluse.



**Caution:** For use with Intermec battery pack Model AB13 only. For power supply, use Intermec Model 073573 or AE19. No user-serviceable parts.

**Attention:** Pour utilisation seulement avec bloc-batterie Intermec modèle AB13. Pour l'alimentation, utilisez le modèle Intermec 073573 ou AE19. Il ne contient aucune pièce réparable par l'utilisateur.

The users of this product are cautioned to use accessories and peripherals approved by Intermec Technologies Corporation. The use of accessories other than those recommended, or changes to this product that are not approved by Intermec Technologies Corporation, may void the compliance of this product and may result in the loss of the user's authority to operate the equipment.

## FCC Digital Emissions Compliance

This equipment has been tested and found to comply with the limits for a Class B digital device, pursuant to Part 15 of the FCC Rules. These limits are designed to provide reasonable protection against harmful interference in a residential installation. This equipment generates uses and can radiate radio frequency energy and, if not installed and used in accordance with the instructions, may cause harmful interference to radio communications. However, there is no guarantee that interference will not occur in a particular installation. If this equipment does cause harmful interference to radio or television reception, which can be determined by turning the equipment off and on, the user is encouraged to try to correct the interference by one or more of the following measures:

- Reorient or relocate the radio or television receiving antenna.
- Increase the separation between the computer equipment and receiver.
- Connect the equipment into an outlet on a circuit different from that to which the radio or television receiver is connected.
- Consult the dealer or an experienced radio television technician for help.

## Canadian Digital Apparatus Compliance

This Class B digital apparatus meets all requirements of the Canadian Interference-Causing Equipment Regulations.

## Conformité aux normes canadiennes sur les appareils numériques

Cet appareil numérique de la classe B respecte toutes les exigences du Règlement sur le matériel brouilleur du Canada.

## Battery Information



**Caution:** The battery pack used in this device may ignite, create a chemical burn hazard, explode, or release toxic materials if mistreated. Do not incinerate, disassemble, or heat above 100°C (212°F). Charge only with Intermec Model AC18. Do not short circuit; may cause burns. Keep away from children.

Use only Intermec battery pack Model AB13. Use of incorrect battery pack may present risk of fire or explosion. Promptly dispose of used battery pack according to the instructions.

**Attention:** Le bloc-piles utilisé dans cet appareil peut prendre feu, constituer un risque de brûlure chimique, exploser ou dégager des substances toxiques s'il est manipulé de façon inappropriée. Ne pas jeter au feu, démonter ou chauffer à plus de 100 °C (212 °F). Rechargez uniquement avec le chargeur Intermec modèle AC18. Ne pas court-circuiter; cela pourrait causer des brûlures. Garder hors de la portée des enfants.

N'utiliser que le modèle de bloc-piles Intermec AB13. L'utilisation d'un mauvais bloc-piles pourrait constituer un risque d'incendie ou d'explosion. Mettre rapidement au rebut tout bloc-piles usé, conformément aux instructions.

## Battery Recycling Information

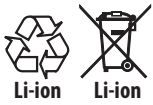

This product contains or uses a lithium-ion (Li-ion) main battery. When the battery reaches the end of its useful life, the spent battery should be disposed of by a qualified recycler or hazardous materials handler. Do not mix this battery with the solid waste stream. Contact your Intermec Technologies Service Center for recycling or disposal information.

Ce produit contient ou utilise une pile principale au lithium-ion (Li-ion). Lorsque la batterie atteint la fin de sa durée de vie utile, la batterie usées doivent être mises aux rebuts par un agent de recyclage ou un manipulateur de matériaux dangereux agréé. Il ne faut pas mélanger la batterie aux autres déchets solides. Pour plus d'informations sur le recyclage ou la mise aux rebuts, contacter votre centre de services Intermec Technologies.

**Note:** In the U.S.A., the EPA does not consider spent Li-ion batteries as hazardous waste.

## Battery Chargers



**Caution:** For use with Intermec battery pack Model AB13 only. For power supply, use Intermec Model 073573 or AE19. No user-serviceable parts.

**Attention:** Pour utilisation seulement avec bloc-batterie Intermec modèle AB13. Pour l'alimentation, utilisez le modèle Intermec 073573 ou AE19. Il ne contient aucune pièce réparable par l'utilisateur.

## Vehicle Docks



**Caution:** For use with Intermec Model PB50 and battery pack Model AB13 only. For power supply, use Intermec Model 073573 or AE19. No user-serviceable parts.

**Attention:** Add translation here.



**Caution:** For continued protection against risk of fire, replace only with same type and ratings of fuse.

**Attention:** Pour une protection continue contre les risques d'incendies, remplacez seulement avec des fusibles du même type et du même calibre.

## Specific Absorption Rate (SAR)

### Radio Wave Exposure and Specific Absorption Rate (SAR) Information for Model BSM-RN41 Configurations with Bluetooth Radio

The FCC permits a maximum SAR value of 1.6 W/kg. For body worn operation, the highest SAR value for the Model PB50, as tested by [\(enter test lab here\)](#), is [\(enter value here\)](#).

This product has been tested and meets the FCC RF exposure guidelines when used with the Intermec accessories supplied or designated for this product. Use of other accessories may not ensure compliance with FCC RF exposure guidelines.

## For Users Outside of the United States or Canada



**Caution:** This marking indicates that the user should read all included documentation before use.



**Caution:** For use with Intermec battery pack Model AB13 only. For power supply, use Intermec Model 073573 or AE19. No user-serviceable parts.

Users of this product are cautioned to use accessories and peripherals approved by Intermec Technologies Corporation. The use of accessories other than those recommended, or changes to this product that are not approved by Intermec Technologies Corporation, may void the compliance of this product and may result in the loss of the user's authority to operate the equipment.

**CE Marking:** Refer to the Declaration of Conformity for a list of the EU Directives and Standards that this product complies with.

## Battery Information



**Caution:** The battery pack used in this device may ignite, create a chemical burn hazard, explode, or release toxic materials if mistreated. Do not incinerate, disassemble, or heat above 100°C (212°F). Charge only with Intermec Model AC18. Do not short circuit; may cause burns. Keep away from children.

Use only Intermec battery pack Model AB13. Use of incorrect battery pack may present risk of fire or explosion. Promptly dispose of used battery pack according to the instructions.

## Battery Recycling Information



This product contains or uses a lithium-ion (Li-ion) main battery. When the battery reaches the end of its useful life, the spent battery should be disposed of by a qualified recycler or hazardous materials handler. Do not mix this battery with the solid waste stream. Contact your Intermec Technologies Service Center for recycling or disposal information.

## Battery Chargers



**Caution:** For use with Intermec battery pack Model AB13 only. For power supply, use Intermec Model 073573 or AE19. No user-serviceable parts.

## Vehicle Docks



**Caution:** For use with Intermec Model PB50 and battery pack Model AB13 only. For power supply, use Intermec Model 073573 or AE19. No user-serviceable parts.



**Caution:** For continued protection against risk of fire, replace only with same type and ratings of fuse.

## 对于美国或加拿大以外的用户



**警告：**该标志表明，用户应在使用前通读所有随附的文档。



**警告：**仅供与 Intermec AB13 型电池组配合使用。请使用 Intermec 073573 或 AE19 型电源。没有可供用户维修的零部件。

敬告本产品的用户，请务必使用 Intermec Technologies Corporation 许可的附件和外围设备。如果使用推荐附件之外的其它附件，或未经 Intermec Technologies Corporation 许可而擅自改装本产品，都可能会使本产品的符合性无效，并可能会导致用户失去操作本设备的权利。

**CE 标记：**请参考“符合性声明”来了解该产品遵守的一揽子 EU 指令和标准。

## 电池信息



**警告：**该装置中所使用的电池包可能着火、造成化学燃烧危险、爆炸，而且如果处理不当会释放有毒物质。请勿烧毁、分解电池，或者加热到 100 摄氏度 (212 华氏度) 以上。只能使用 Intermec AC18 型充电器充电。请勿使电池短路，以免引起火灾。请不要让儿童接触到电池。

仅供使用的 Intermec 电池包型号是 AB13。使用电池包错误可能引起火灾或爆炸。请根据说明及时处理用过的电池包。

## 电池循环利用



本产品包含或使用锂离子 (Li-ion) 主电池。电池达到使用寿命后，请交由合格的回收者或危险材料处理者进行处理。请勿将使用后的电池混同其他固体废弃物处理。请联系 Intermec 技术服务中心了解有关回收或处理的信息。

## 电池充电器



**警告：**仅供与 Intermec AB13 型电池组配合使用。请使用 Intermec 073573 或 AE19 型电源。没有可供用户维修的零部件。

## 车载底座



**注意：**仅限与 Intermec PB50 型和 AB13 型电池配套使用。请使用 Intermec 073573 或 AE19 型电源。无用户可维修的部件。



**注意：**为长期防止火灾的发生，请仅使用相同类型和额定值的保险丝进行更换。

## Für Benutzer außerhalb von Kanada oder den Vereinigten Staaten



**Vorsicht:** Diese Kennzeichnung weist darauf hin, dass der Benutzer vor dem Gebrauch alle mitgelieferten Unterlagen lesen soll.





**Vorsicht: Nur zur Verwendung mit dem Intermec-Akkusatz, Modell AB13. Als Netzteil Intermec Modell 073573 oder AE19 verwenden. Enthält keine Teile, die vom Benutzer gewartet werden können.**

Die Benutzer dieses Produkts werden darauf hingewiesen, nur Zubehörteile und Peripheriegeräte zu verwenden, die von Intermec Technologies Corporation genehmigt sind. Falls nicht empfohlene Zubehörteile verwendet oder an diesem Produkt Änderungen vorgenommen werden, die nicht von Intermec Technologies Corporation genehmigt sind, kann dadurch die behördliche Konformität des Produkts verletzt werden und der Benutzer die Berechtigung zur Verwendung des Geräts verlieren.

**CE-Kennzeichnung:** Die Konformitätserklärung enthält eine Liste der EU-Richtlinien und Normen, denen das Produkt entspricht.

## Akku-Informationen



**Vorsicht: Der in diesem Gerät verwendete Akkusatz kann sich bei Missbrauch entzünden, chemische Verätzungen verursachen, explosieren oder toxische Substanzen freisetzen. Nicht verbrennen, zerlegen oder über 100 °C (212 °F) erwärmen. Nur mit Intermec Modell AC18 aufladen. Keinen Kurzschluss verursachen; Verbrennungsgefahr. Von Kindern fern halten.**

**Nur Intermec Akkusatz-Modell AB13 verwenden. Wenn ein falscher Akkusatz verwendet wird, besteht Brand- oder Explosionsgefahr. Den verbrauchten Akkusatz sofort gemäß Anweisungen entsorgen.**

## Informationen zum Recycling von Batterien

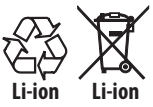

Dieses Produkt enthält oder verwendet einen Lithiumionen-Hauptakku. Wenn die Batterie ausgedient hat, sollte sie durch einen qualifizierten Recycler oder durch den Sondermüll entsorgt werden. Werfen Sie die Batterie nicht in den Abfall. Setzen Sie sich mit Ihrem Intermec Technologies Service-Zentrum in Verbindung, um weitere Informationen zum Recycling oder Entsorgen zu erhalten.

## Akkuladegeräte



**Vorsicht: Nur zur Verwendung mit dem Intermec-Akkusatz, Modell AB13. Als Netzteil Intermec Modell 073573 oder AE19 verwenden. Enthält keine Teile, die vom Benutzer gewartet werden können.**

## Fahrzeug-Andockstationen



**Vorsicht: Nur zur Verwendung mit dem Intermec Modell PB50 und Akkusatz, Modell AB13. Als Netzteil Intermec Modell 073573 oder AE19 verwenden. Enthält keine Teile, die vom Benutzer gewartet werden können.**



**Vorsicht: Für fortwährenden Schutz gegen Brand nur durch eine Sicherung gleichen Typs und Nennwertes ersetzen.**

## 미국 및 캐나다 이외의 거주자의 경우



주의 : 이 표시는 제품 사용 전에 모든 설명서 내용을 읽어야 한다는 것을 나타냅니다 .



주의 : 인터멕 건전지 AB13 모델과 함께만 사용 . 전원 공급은 Intermec 073573 또는 AE19 모델을 사용하십시오 . 사용자 조작 사용 부품 아님 .

Intermec Technologies Corporation 에서 승인한 부속품 및 주변 기기를 사용하는 본 제품의 사용자는 주의를 기울여야 합니다 . 권장되지 않은 부속품을 사용하거나 Intermec Technologies Corporation 의 승인 없이 본 제품을 변경할 경우 , 본 제품의 보증이 무효화되거나 장비 조작에 대한 사용자의 권한이 박탈될 수 있습니다 .

**유럽인증마크 (CE Marking):** 이 제품이 준수하는 EU 지침 및 표준 목록에 대한 적합성 선언을 참조하십시오 .

## 배터리 정보



T 주의 : 이 장치에 사용된 배터리 팩은 잘못 다룰 경우 불이 붙거나 화학 반응을 일으키거나 폭발하거나 또는 유독 물질이 흘러나올 수 있습니다 . 배터리를 불에 태우거나 분해하거나 100°C (212°F) 이상의 열을 가하지 마십시오 . Intermec AC18 모델로만 충전하십시오 . 배터리를 단락시키지 마십시오 . 화재가 발생할 수 있습니다 . 어린이 손이 닿지 않는 곳에 보관하십시오 .

Intermec 배터리 팩 AB13 모델만 사용하십시오 . 그 외 배터리 팩을 사용할 경우 화재나 폭발 위험이 있습니다 . 다 쓴 배터리 팩은 지침에 따라 올바르게 폐기하십시오 .

## 배터리 재활용 정보



이 제품은 리튬 이온 배터리를 내장 또는 사용하고 있습니다. 배터리의 수명이 다한 경우, 다 쓴 배터리는 반드시 공인된 폐기 업체나 위험 물질 처리 작업장을 통해 안전하게 폐기하십시오. 이 배터리는 다른 쓰레기와 함께 처리할 수 없습니다. 재활용이나 폐기에 대한 기타 자세한 사항은 Intermec 기술 서비스 센터에 문의하십시오.

## 배터리 충전기



주의: 인터맥 건전지 AB13 모델과 함께만 사용. 전원 공급은 Intermec 073573 또는 AE19 모델을 사용하십시오. 사용자 조작 사용 부품 아님.

## 차량 독



주의: Intermec 모델 PB50 및 배터리 팩 모델 AB13 만 사용하십시오. 전원 공급은 Intermec 모델 073573 또는 AE19 를 사용하십시오. 사용자 서비스 가능한 부품이 없습니다.



주의: 화재의 위험으로부터 향후 지속적으로 예방하려면 동일한 유형 및 정격의 퓨즈로만 교체하십시오.

## Para usuários fora do Canadá ou dos Estados Unidos



**Cuidado:** Esta identificação indica que o usuário deve ler toda a documentação fornecida antes do uso.



**Cuidado:** Para uso apenas com a bateria modelo AB13 da Intermec. Use o modelo 073573 ou AE19 da Intermec como fonte de alimentação. Este equipamento não contém peças que possam ser reparadas pelo usuário.

Se advierte a los usuarios de este producto que usen accesorios y periféricos aprobados por Intermec Technologies Corporation. El uso de accesorios aparte de los recomendados, o los cambios a este producto que no estén aprobados por Intermec Technologies Corporation, pueden anular el cumplimiento de este producto y ocasionar la pérdida de la autorización del usuario para operar el equipo.

**Marcas CE:** Consulte na Declaração de Conformidade a lista de Diretivas e Normas da União Europeia com as quais este produto está em conformidade.

## Informações sobre a bateria



**Cuidado:** A bateria utilizada neste dispositivo pode pegar fogo, criar risco de queimadura química, explodir ou exalar materiais tóxicos se abusada. Não incinerar, desmontar nem aquecer a bateria a mais de 100°C (212°F). Carregar apenas com o modelo de carregador AC18 da Intermec. Não provocar curto-circuito, pois pode causar queimaduras. Manter afastada de crianças.

Apenas a bateria da Intermec modelo AB13. O uso de uma bateria incorreta pode gerar risco de incêndio ou explosão. Descartar imediatamente as baterias usadas segundo as instruções fornecidas.

## Informações de Reciclagem de Bateria



Este produto contém ou usa uma bateria principal de íon de lítio (Li-ion). Quando a bateria chega ao fim da sua vida útil, deve ser descartada por um profissional de reciclagem qualificado ou por um especialista no manuseio de materiais perigosos. Não misture a bateria com fluxo de lixo sólido. Entre em contato com seu Centro de Serviços de Tecnologia Intermec para informações de reciclagem ou descarte.

## Corregadores de baterias



**Cuidado:** Para uso apenas com a bateria modelo AB13 da Intermec. Use o modelo 073573 ou AE19 da Intermec como fonte de alimentação. Este equipamento não contém peças que possam ser reparadas pelo usuário.

## Acopladores para veículos



**Cuidado:** Para uso apenas com o modelo PB50 e a bateria modelo AB13 da Intermec. Use o modelo 073573 ou AE19 da Intermec como fonte de alimentação. Este equipamento não contém peças que possam ser reparadas pelo usuário.



**Cuidado:** Para desfrutar de proteção contínua contra risco de incêndio, trocar apenas por fusível do mesmo tipo e mesmas especificações elétricas.

## Для пользователей вне Соединенных Штатов или Канады



**Осторожно:** Эта пометка означает, что пользователь должен прочитать всю прилагаемую документацию, прежде чем начинать работу.



**Осторожно:** Для использования только с батарейным источником питания модели Intermec AB13. В качестве блока питания используйте Intermec модели 073573 или AE19. Детали, обслуживаемые пользователем, отсутствуют.

Пользователи этого продукта предупреждаются, что они должны использовать принадлежности и периферийные устройства, утвержденные Intermec Technologies Corporation. Использование принадлежностей, не являющихся рекомендованными, или внесение в этот продукт изменений, не утвержденных Intermec Technologies Corporation, может сделать продукт не соответствующим требованиям и привести к утрате пользователем права работать с данным оборудованием.

**Маркировка CE:** Список директив и стандартов ЕС, которым соответствует данный продукт, см. в Декларации соответствия.

## Информация по батареям



**Осторожно:** При неправильном обращении батарейный источник питания, используемый в этом устройстве, может воспламениться, создать опасность химического ожога, взорваться или выделять ядовитые материалы. Не сжигайте, не разбирайте, не допускайте нагрева выше 100°C (212 °F). Для зарядки используйте только устройство Intermec модели AC18. Не замыкайте контакты коротко – это может причинить ожог. Прячьте от детей.

Используйте только батарейный источник питания Intermec модели AB13. Использование неподходящего батарейного источника питания сопряжено с опасностью возгорания или взрыва. Незамедлительно ликвидируйте использованный батарейный источник питания в соответствии с инструкциями.

## Информация по утилизации батареек



В данном изделии содержится или используется литиево-ионная (Li-ion) батарейка. Ликвидацию использованной батарейки, исчерпавшей свой ресурс, должно осуществлять специализированное предприятие по утилизации или обращению с опасными материалами. Эта батарейка ни в коем случае не должна попасть в обычные твердые отходы. По вопросам утилизации или ликвидации обращайтесь в соответствующий сервис-центр компании Intermec Technologies.

## Зарядные устройства



**Для использования только с батарейным источником питания модели Intermec AB13. В качестве блока питания используйте Intermec модели 073573 или AE19. Детали, обслуживаемые пользователем, отсутствуют.**

## Автомобильные стойки



**Осторожно:** для использования только с Intermec Model PB50 и батарейным источником питания Intermec AB13. В качестве блока питания используйте Intermec 073573 или AE19. Детали, обслуживаемые пользователем, отсутствуют.



**Осторожно:** Для постоянной защиты от риска пожара заменяйте только плавкой вставкой того же типа и номинала.

## Para usuarios fuera de Canada o de los Estados Unidos



**Precaución:** Esta marca indica que el usuario debe leer toda la documentación incluida antes del uso.



**Precaución:** Para usarse solamente con la batería Intermec Modelo AB13. Para la fuente de alimentación, use el Modelo 073573 o AE19 de Intermec. No hay piezas a las cuales pueda dar servicio el usuario.

Os usuários deste produto devem usar acessórios e periféricos aprovados pela Intermec Technologies Corporation. Usar acessórios não recomendados, ou fazer alterações neste produto não aprovadas pela Intermec Technologies Corporation, poderá anular a conformidade deste produto e resultar na perda da permissão do usuário de utilizar o equipamento.

**Marcas de la CE:** Remítase a la Declaración de Conformidad para ver una lista de las Directrices y Estándares de la UE con los cuales cumple este producto.

## Información de la batería



**Precaución:** La batería que se usa en este dispositivo puede encenderse, crear un peligro de quemadura química, explotar o expedir materiales tóxicos si se trata indebidamente. No la incinere, desarme ni caliente sobre 100°C (212°F). Cargue solamente con el Modelo AC18 de Intermec. No haga cortocircuitos porque pueden causar quemaduras. Manténgala alejada de los niños.

Use sólo la batería Intermec modelo AB13. El uso de la batería incorrecta puede presentar peligro de incendio o de explosión. Descarte rápidamente la batería usada según las instrucciones.

## Información acerca del reciclaje de la batería

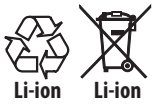

Este producto contiene o usa una batería principal de iones de litio (Li-ion). Cuando la batería llega al final de su vida útil, debe ser desechada por personal especializado en reciclaje de materiales o manejo de materiales peligrosos. No mezcle la batería con otros residuos sólidos. Pónganse en contacto con su Centro de servicio de Intermec Technologies para obtener información sobre reciclaje o desecho de materiales.

## Cargadores de batería



**Caution:** Para usarse solamente con la batería Intermec Modelo AB13. Para la fuente de alimentación, use el Modelo 073573 o AE19 de Intermec. No hay piezas a las cuales pueda dar servicio el usuario.

## Acopladores para vehículos



**Precaución:** Para usarse solamente con el Modelo PB50 y la batería Modelo AB13. Para la fuente de alimentación, use el Modelo 073573 o AE19 de Intermec. No hay piezas a las cuales pueda dar servicio el usuario.



**Precaución:** Para continuar la protección contra el peligro de incendio, cambie sólo por el mismo tipo y capacidad nominal de fusible.



**Worldwide Headquarters**  
6001 36th Avenue West  
Everett, Washington 98203  
U.S.A.

**tel** 425.348.2600

**fax** 425.355.9551

[www.intermec.com](http://www.intermec.com)

© 2007 Intermec Technologies  
Corporation. All rights reserved.

PB50 Compliance Insert



P/N 933-108-001