

G6 OPT

Installation Guide

Revision 5

July 2014



Table of Contents

1	Introduction	4
2	Safety & Compliance Information.....	5
2.1	Preliminary Precautions	5
2.2	Emergency Total Electrical Shut-Off	5
2.3	Total Electrical Shut-Off Before Access	5
2.4	Evacuation, Barricading and Shut-Off	5
2.5	Read the Manual.....	5
2.6	Follow the Regulations.....	5
2.7	Replacement Parts.....	5
2.8	Safety Symbols and Warning Words.....	6
2.9	Prevent Explosions and Fires	6
2.10	No Open Flames	6
2.11	No Sparks - No Smoking.....	6
2.12	Working Alone.....	6
2.13	Working With Electricity Safely.....	6
2.14	Hazardous Materials	7
2.15	Informing Emergency Personnel	7
2.16	Computer Programs and Documentation	7
2.17	Approvals	7
2.18	European Directives.....	7
2.19	Important Radio, FCC and Interference Information	8
2.20	RF Exposure information	8
2.21	Laser Warning.....	8
3	Product Features	9
3.1	Location of Features	9
3.2	Accessories in the box	10
3.3	Location of Mounting Points.....	10
4	Installation.....	11
4.1	Considerations for New Enclosures	11
4.2	Tools Required.....	13
4.3	In A New Pump or Cabinet.....	13

4.4	Replacement of a G5 Product.....	14
4.4.1	Power Supply Considerations	14
4.4.2	Selection of Retrofit Options	15
4.4.3	Physical Retrofit.....	15
4.4.4	Retrofit Kit Parts.....	16
4.5	Wiring.....	17
4.5.1	Protective Earth	17
4.5.2	Ethernet LAN	17
4.5.3	DC Power Supply.....	17
4.5.4	Main Power Supply Wiring	18
4.5.5	Wiring Completion.....	18
5	First Power-Up	19
6	Basic Maintenance.....	20
6.1	Cleaning.....	20
6.2	Paper-Roll Replacement (only for models with printer).....	20
6.3	Clearing a Paper Jam (only for models with printer)	22
7	Removal & Reinstallation	24
8	Drawings	26
8.1	Dimensions	26
8.2	Mounting – New Installation	28
8.3	Retrofit for G5 OPT with Motorised Card Reader.....	30
8.4	Retrofit for G5 OPT with Manual Card Reader.....	31
9	Typical Wiring	32
10	Notes.....	33

1 Introduction

Congratulations on your purchase of a Generation 6 Outdoor Payment Terminal (G6 OPT). This product is the result of years of development and experience crafting terminal products for the retail petroleum industry and represents the state of the art in equipment for your customers.

When properly installed and maintained your terminal will provide many years of service. There are few moving parts and minimal connections, and all parts have been designed to give a good service life.

Please read this guide thoroughly before starting installation.

This guide is intended for the following variants of the G6 OPT:

Model →	6500x	6505x	6520x	6525x
Features ↓				
Contactless		✓		✓
2D Barcode			✓	✓

The G6 OPT is intended for use on fuel station forecourts, but is also suitable for mounting into any appropriate, physically secure cabinet.

This guide deals primarily with the requirements for mounting into a fuel pump-head, however the steps are applicable to any cabinet. Specific steps and precautions for pump head installation are highlighted.

2 Safety & Compliance Information

This section introduces the hazards and safety precautions associated with installing, inspecting, maintaining or servicing this product. Before performing any task on this product, read this safety information and the applicable sections in this manual, where additional hazards and safety precautions for your task will be found. Fire, explosion or electrical shock could occur and cause death or serious injury if these safe service procedures are not followed.

2.1 Preliminary Precautions

You are working in a potentially dangerous environment of flammable fuels, vapours, and high voltage. Only trained or authorized individuals knowledgeable in the related procedures should install, inspect, maintain or service this equipment.

2.2 Emergency Total Electrical Shut-Off

The first and most important information you must know is how to stop all fuel flow to the pump and island. Locate the switch or circuit breakers that shut-off all power to all fuelling equipment and dispensing devices.

2.3 Total Electrical Shut-Off Before Access

Any procedure requiring access to electrical components or the electronics of a pump/dispenser requires total electrical shut-off of that unit. Know the function and location of this switch or circuit breaker before inspecting, installing, maintaining, or servicing.

2.4 Evacuation, Barricading and Shut-Off

Any procedures requiring accessing a pump/dispenser head requires the following three actions:

- An evacuation of all unauthorized persons and vehicles
- Using safety tape or cones as barricades to the effected units
- A total electrical shut-off of that unit

2.5 Read the Manual

Read, understand and follow this manual and any other labels or related materials supplied with this equipment. If you do not understand a procedure, call an Invenco Authorized Service Contractor. It is imperative to your safety and the safety of others to understand the procedures before beginning work.

2.6 Follow the Regulations

There is applicable information in OSH regulations; and national, state, and local codes which must be followed. Failure to install, inspect, maintain or service this equipment in accordance with these codes, regulations and standards may lead to legal citations with penalties or affect the safe use and operation of the equipment.

2.7 Replacement Parts

Use only genuine Invenco replacement parts and retrofit kits on your installation. Using parts other than genuine Invenco replacement parts could create a safety hazard and violate local regulations.

2.8 Safety Symbols and Warning Words

This section provides important information about warning symbols and boxes.

Alert Symbol: This safety alert symbol is used in this manual to alert you to a precaution which must be followed to prevent potential personal safety hazards. Obey safety directives that follow this symbol to avoid possible injury or death.



Signal Words: These signal words used in this manual and on warning labels tell you the seriousness of particular safety hazards. The precautions that follow must be followed to prevent death, injury or damage to the equipment:

- **WARNING** - This alerts you to a hazard or unsafe practice that could result in death or serious injury.
- **CAUTION with Alert symbol** - This signal word designates a hazard or unsafe practice which may result in minor injury.
- **CAUTION without Alert symbol** - When used by itself, **CAUTION** designates a hazard or unsafe practice which may result in property or equipment damage.

2.9 Prevent Explosions and Fires

Fuels and their vapours will become explosive if ignited. Spilled or leaking fuels cause vapours. Even filling customer tanks will cause explosive vapours in the vicinity of dispenser or island.

2.10 No Open Flames

Open flames from matches, lighters, welding torches or other sources can ignite fuels and their vapours.

2.11 No Sparks - No Smoking

Sparks from starting vehicles, starting or using power tools, burning cigarettes, cigars or pipes can also ignite fuels and their vapours. Static electricity, including an electrostatic charge on your body, can cause a spark sufficient to ignite fuels and their vapours. After getting out of a vehicle, touch the metal of your vehicle to discharge any electrostatic charge before you approach the dispenser island.

2.12 Working Alone

It is highly recommended that someone who is capable of rendering first aid be present during servicing. Be familiar with Cardiopulmonary Resuscitation (CPR) methods if you are working with or around high voltages. This information is available from the Red Cross. Always advise the station personnel about where you will be working, and caution them not to activate power while you are working on the equipment. Use the OSHA tag out and lock out procedures. If you are not familiar with this requirement, refer to information in the service manual and OSHA documentation.

2.13 Working With Electricity Safely

Be sure to use safe and established practices in working with electrical devices. Poorly wired devices may cause a fire, explosion or electrical shock. Be sure grounding connections are properly made. Make sure that sealing devices and compounds are in place. Be sure not to pinch wires when replacing covers. Follow OSHA Lock-Out and Tag-Out requirements. Station employees and service contractors need to understand and comply with this program completely to ensure safety while the equipment is down.

2.14 Hazardous Materials

Some materials present inside electronic enclosures may present a health hazard if not handled correctly. Be sure to clean hands after handling equipment. Do not place any equipment in mouth.

2.15 Informing Emergency Personnel

Compile the following information for emergency personnel:

- Location of accident (e.g. address, front/back of building, etc.)
- Nature of accident (e.g. possible heart attack, run over by car, burns, etc.)
- Age of victim (e.g. baby, teenager, middle-age, elderly)
- Whether or not victim has received first aid (e.g. stopped bleeding by pressure, etc.)
- Whether or not victim has vomited (e.g. if swallowed or inhaled something, etc.)

IMPORTANT: Oxygen may be needed at scene if gasoline has been ingested or inhaled. Seek medical advice immediately.

2.16 Computer Programs and Documentation

All Invenco Group Ltd., computer programs (including software on discs and within memory chips) and documentation are copyrighted by, and shall remain the property of, Invenco Group Ltd. Such computer programs and documents may also contain trade secret information. The duplication, disclosure, modification, or unauthorized use of computer programs or documentation is strictly prohibited, unless otherwise licensed by Invenco Group Ltd.

2.17 Approvals

Invenco develops and maintains its hardware and software products using industry-standard quality processes, and is audited by the MasterCard TQM (Terminal Quality Management) scheme.

The G6 OPT has the following approvals:

- TQM (Quality)
- PCI (Payment Card Industry) EMV standards (Security)
- EN 55022 (Emissions)
- EN55024 (Immunity)
- EN 60950 (Safety)
- EN 301 489 & EN 302 291 (Radio)

2.18 European Directives

The G6 OPT complies with the necessary European Directives for the CE mark.



2.19 Important Radio, FCC and Interference Information

Changes or modifications not expressly approved by the manufacturer could void the user's authority to operate the equipment.

As stated on the device: This device complies with Part 15 of the FCC Rules. Operation is subject to the following two conditions: (1) this device may not cause harmful interference, and (2) this device must accept any interference received, including interference that may cause undesired operation.

The G6 OPT device is an FCC Class A device that complies with the Class B limits

NOTE: This equipment has been tested and found to comply with the limits for a Class B digital device, pursuant to Part 15 of the FCC Rules. These limits are designed to provide reasonable protection against harmful interference in a residential installation. This equipment generates, uses and can radiate radio frequency energy and, if not installed and used in accordance with the instructions, may cause harmful interference to radio communications. However, there is no guarantee that interference will not occur in a particular installation. If this equipment does cause harmful interference to radio or television reception, which can be determined by turning the equipment off and on, the user is encouraged to try to correct the interference by one or more of the following measures:

- Increase the separation between the equipment and receiver.
- Connect the equipment into an outlet on a circuit different from that to which the receiver is connected.

2.20 RF Exposure information

Versions of this device have contactless card reading circuitry that transmits electromagnetic waves. The energy from this circuitry is mostly a magnetic field. The power output of this transmitter is much less than 200mW threshold for any SAR risk and is therefore exempt from SAR evaluation and considered to be safe to use in normal operation.

To further minimise any risk of exposure it is recommended that the device be installed such that there are no obstructions that would prevent a user from having a minimum 20cm clearance between their head and the contactless symbol displayed on the device when the user is in the process of presenting a contactless payment card to the device.

2.21 Laser Warning

Some models of the G6 OPT incorporate a barcode reader. The barcode reader incorporates a laser aiming system. The Laser has a Class 2 output power to IEC 60825-1:2007:

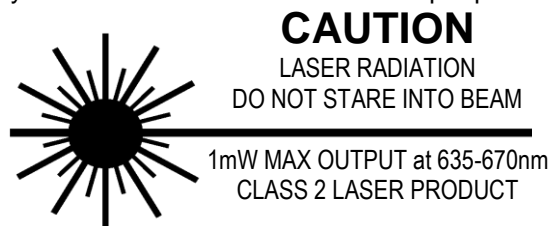





3 Product Features

3.1 Location of Features



3.2 Accessories in the box

<p>1. Spindle for Paper Roll retention</p>	
<p>2. Paper Roll 57mm x 110mmDia, 72gsm, thermal, top-coated, outdoor rated. Recommended replacement paper is NCR, P/N 0202090</p>	
<p>3. Mounting screws Stainless Steel, M4 x 10mm, 12 pieces (Use Hex or Allen 3mm screw driver)</p>	
<p>4. Mounting Gasket</p>	

3.3 Location of Mounting Points

Green highlights are standard mounting points for a new installation.
Blue highlights are for retro-fit mounting when replacing a G5 OPT.
See the Drawings at the end of this manual for panel cut-out information.

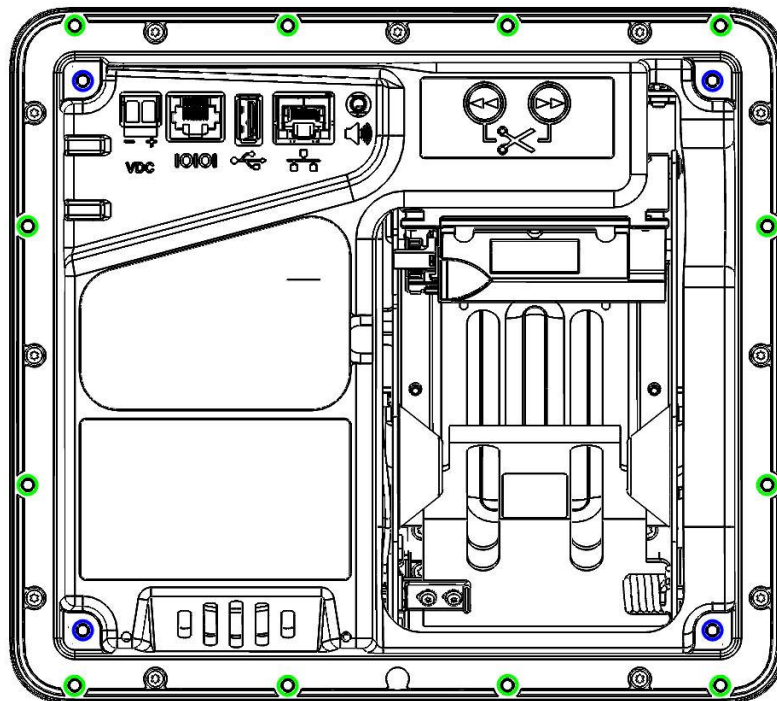

4 Installation

4.1 Considerations for New Enclosures

Pump manufacturers generally will not allow third parties to modify their pumps because they have many safety certifications that can easily be invalidated. Therefore if installing into a pump head the pump manufacturer **MUST** perform the necessary modifications for you.

The following factors need to be considered in designing an installation for the G6 OPT:

1. Fire

The enclosure must be designed to meet the requirements of ISO/EN 60950-1 for **FIRE ENCLOSURES**.

2. ATEX (Explosive Atmospheres)

The G6 OPT has openings that prevent it being gas-tight, and consequently it must be located away from any hazardous zone. Refer to local laws and regulations for hazardous zones to determine a suitable mounting arrangement for the G6 OPT. The enclosure in which the G6 OPT is mounted should also be designed to prevent a dangerous build-up of explosive gases.

3. Security

The enclosure must provide sufficient physical security to protect the public from the hazards within, and to reduce the possibility of tampering with the OPT.

4. Power & Data

- a. The enclosure must provide mains power. The requirements are:
 - i. A permanently-wired connection or a socket.
 - ii. A protective earth connection
 - iii. The outlet **may** be switched if it is a socket, and **must** be switched if it is permanently wired.
- b. The enclosure must provide an Ethernet data connection. The requirements are:
 - i. Capable of at least 10Mbps (preferably 100Mbps)
 - ii. The connection must be either a socket into which a standard Ethernet patch cable can be connected, or a cable that is terminated in a standard RJ45 plug suitable for direct connection into the OPT LAN socket.
 - iii. Minimum cable standard should be Cat5e
- c. The enclosure may provide an alternative data connection for terminals that have optional communications modules installed. Please consult with Invenco for what options are available.

5. Accessibility

The enclosure must be designed and mounted so that disabled persons are able to operate the OPT.

6. Materials

The enclosure and all its components must be constructed of durable materials suitable for the intended location.

7. Door cut-out

- a. Use the wireframe drawings in Section 8 to determine the extra space required for the front of the terminal (larger than cut-out).
- b. The edge of the cut-outs should be smooth and free of burrs, and the surface of the door around the cut-out should be clean, and planar within ± 1 mm.

8. Hinging

Use the following diagrams as a guide when designing an enclosure and/or door to house the G6 OPT. This will ensure there is a clearance between the G6 OPT

housing and the opening. Right-side hinging is recommended by Invenco.

Description	Photo reference
<p>Side hinging points diagram.</p>	<p>A 3D perspective diagram of the device from the side. It shows the 'Closest Left-Hinging Point' and 'Closest Right-Hinging Point'. A 'Mounting Plane' is indicated with a horizontal line. Dimensions are provided: 96 and 110 for the left side, and 321 and 336 for the total width. Radii R240 and R335 are shown at the top corners.</p>
<p>Top-bottom hinging diagram.</p>	<p>A 3D perspective diagram of the device from the top. It shows the 'Closest Upper-Hinging Point' and 'Closest Lower-Hinging Point'. A 'Mounting Plane' is indicated with a horizontal line. Dimensions are provided: 116 and 130 for the upper section, and 116, 130, 316, and 331 for the lower section. Radii R330 are shown at the front corners.</p>

9. Water-Tightness

The G6 OPT is rated for IP24 on its external parts.

The parts sitting inside the pump/pedestal enclosure are designed to reduce the likelihood of rain splashes entering the electronics but the enclosure must provide good protection from water.

The door should have a water seal against the enclosure, and there should be good drainage and/or a system to reduce excessive condensation build-up and dripping.

4.2 Tools Required

The following tools are required to mount the G6 OPT:

- Torx T20 screw driver (if replacing a G5 OPT)
- Hex 3mm screw driver or Allen key (for mounting the G6 OPT)
- Philips #1 or Flat 5mm screw driver (for connections on the power supply)
- Small adjustable spanner (for earth connections inside the cabinet)
- Side cutters (to trim the cable tie(s))
- Cable ties
- Additional hand tools may be required if retrofitting into a non-standard existing enclosure.



WARNING – Do NOT use power tools if working on a fuel station forecourt. Any spark could cause an explosion.

4.3 In A New Pump or Cabinet

When the doors have been pre-fabricated the G6 OPT mounting can take place:

- Unpack the G6 OPT from its packing.
There will be twelve M4x8mm screws for mounting the G6 OPT.
- Unlock and open the pump door
- Stick the mounting gasket onto the OPT.
 - Peel the thin backing off to expose the adhesive.
 - Carefully align the gasket over the mounting surface.
 - Gently press the gasket down to get a good bond.
 - Remove the thick backing, taking care not to tear the gasket.
- Hold the OPT outside the pump, and locate at least one of the top mounting screws.
Semi-tighten.
- Start several of the remaining support screws around the OPT.
- Check the OPT is aligned with any features on the pump door, and then tighten the screws.
- Insert and tighten all remaining screws.

See section 8.2 for a mounting diagram.

Once the physical mounting is complete, proceed to Section 4.5 for wiring instructions.

4.4 Replacement of a G5 Product

The G6 OPT is designed to fit into the existing cut-out created for the G5 OPT to allow an easy upgrade.

To simplify this process a Retrofit Kit is available for either side-mounting or top/bottom-mounting, depending on the model of G5 OPT being replaced.

Before beginning, determine whether the existing G5 OPT is:

- side-mounted (with a motorised card reader), or
- top/bottom-mounted (with a manual card reader).

4.4.1 Power Supply Considerations

The G5 OPT was typically installed with one of the following power supplies:

- Meanwell S-100-24
- Franmar S-100F-24

Either of these power supplies is quite capable of driving a single G6 OPT.

Some installations may have used a single supply to drive two G5 OPTs, in which case care needs to be paid to the maximum internal temperature of the enclosure, to avoid the power supply becoming overloaded after de-rating for temperature.

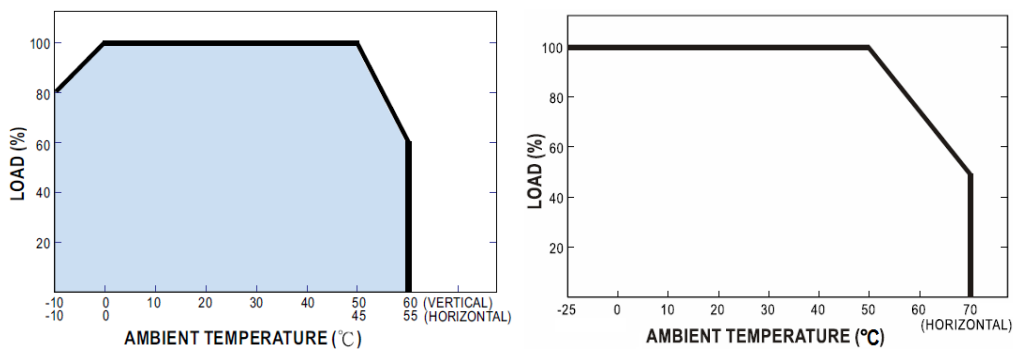

The G6 OPT draws considerably more power than the older terminals and while two terminals will likely operate from a single supply, Invenco does not guarantee error-free operation.



De-rating curves for typical G5 OPT (left) and recommended G6 OPT (right) power supplies.

4.4.2 Selection of Retrofit Options

There are two distinct models of G5 OPT that can be replaced with a G6 OPT. Below are the models of G5 OPT, and the list of associated parts needed for a retrofit for each.

<p>Motorised Card Reader (Side-Mounted)</p> 	<p>Requires EZ0123 Retrofit Kit 1, containing:</p> <ul style="list-style-type: none"> • MP0146 – Left Side Bracket • MP0147 – Right Side Bracket • MS0044 – M4 Screws (qty=8)
<p>Manual Card Reader (Top/Bottom-Mounted)</p> 	<p>Requires EITHER EZ0124 Retrofit Kit 2, containing:</p> <ul style="list-style-type: none"> • MP0136 – Top Bracket • MP0137 – Bottom Bracket • MS0044 – M4 Screws (qty=8) <p>OR EZ0125 Retrofit Kit 3, containing:</p> <ul style="list-style-type: none"> • MP0156 – Front Escutcheon Mount • MS0044 – M4 Screws (qty=8)

4.4.3 Physical Retrofit

Step	Description
1.	Remove the existing G5 OPT.
2.	Disconnect the mains power to the power supply in the normal way.
3.	<p>Unplug both the low-voltage connector and Ethernet connector. Retain the Ethernet cable for later reconnection.</p> <p>Disconnect the low-voltage cable from the power supply and replace it with either:</p> <ul style="list-style-type: none"> ➤ cable EK0070 (available from Invenco), or ➤ the cable specified and supplied by your customer.
4.	Remove the plastic front bezel around the G5 OPT and discard.
5.	Loosen, and then remove the four M4 mounting screws holding the G5 OPT to the door.
6.	Remove the G5 OPT from the back of the door, and package it for disposal or return.
7.	Open the retrofit kit and check the contents. It should have one or two brackets (depending on kit purchased) appropriate to convert the existing to G6 OPT version, and eight screws.
8.	Check the bracket placing – they are not symmetric. Use the pictures below as a guide.
9.	Use four of the supplied screws to mount the bracket(s) onto the door. Leave the screws loose so the brackets can move a little.
10.	Remove the G6 OPT from its packaging, and inspect it for damage.

11.	<p>The sealing gasket will be in the carton with the G6 OPT.</p> <ul style="list-style-type: none"> • Place the G6 OPT face-down onto a soft clean surface. • Stick the mounting gasket onto the OPT. <ul style="list-style-type: none"> ➤ Peel the thin backing off to expose the adhesive. ➤ Carefully align the gasket over the mounting surface. ➤ Gently press the gasket down to get a good bond. ➤ Remove the thick backing, taking care not to tear the gasket.
12.	Insert but don't tighten screws onto the upper bracket (top/bottom mount) or upper positions of each bracket (side mount).
13.	Insert the remaining two screws.
14.	Tighten all four screws into the G6 OPT.
15.	<p>The existing mounting points for the old G5 OPT should be slotted to allow for adjustment of the mounting.</p> <p>Gently press the G6 OPT onto the door to ensure the gasket forms a good seal, and then tighten the screws holding the mounting brackets to the door.</p>
16.	Check for a good seal around the G6 OPT, and for proper alignment of the G6 OPT with any external features on the pump and adjust the mountings if necessary.
17.	<p>Plug both the Ethernet and the new low-voltage cables into the correct ports on the G6 OPT.</p> <ul style="list-style-type: none"> ➤ Use cable ties to secure the cables to the G6 OPT and to other parts of the pump as necessary. ➤ Ensure the cables allow the door to open and close properly and the cables are not pinched or snagged anywhere.
18.	When the rest of the site is ready, reconnect the mains power to the power supply.

4.4.4 Retrofit Kit Parts

<p>EZ0123 Side Mount Kit</p>	<p>MP0146 – Left: MP0147 – Right:</p>
<p>EZ0124 Top/Bottom Mount Kit</p>	<p>MP0136 – Top: MP0137 – Bottom: MPO</p>
<p>EZ0125 Escutcheon Mount Kit</p>	<p>MP0156 – Escutcheon:</p>

4.5 Wiring

Three connections need to be made to the G6 OPT:

1. Protective Earth
2. Ethernet LAN
3. DC Power supply

The DC power supply cable also needs to be connected to the power supply.

4.5.1 Protective Earth

The G6 OPT is provided with an Earth Tab.

- Models with a printer have the tab mounted on the bottom of the paper-holder frame.
- Models without a printer have the tab in the lower area of the rear plastic cover.

The tab must be connected to the pump (or cabinet) frame to provide protection from both power faults and static discharges. The earth wire must be minimum 1.5mm² and both it and the earth stud must meet local regulations.

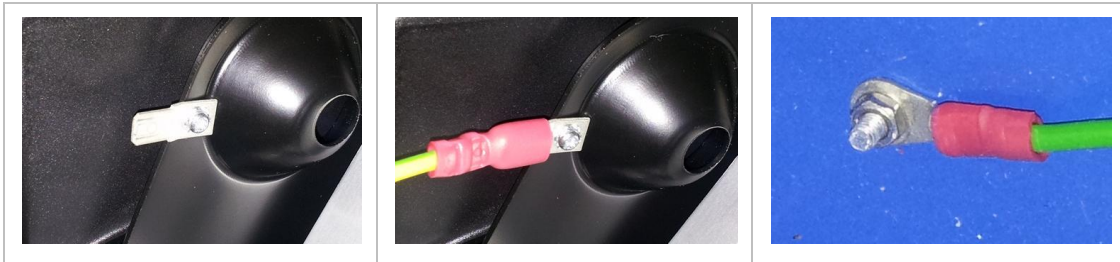

4.5.2 Ethernet LAN

The Ethernet cable is plugged into the correct connector on the rear of the G6 OPT:

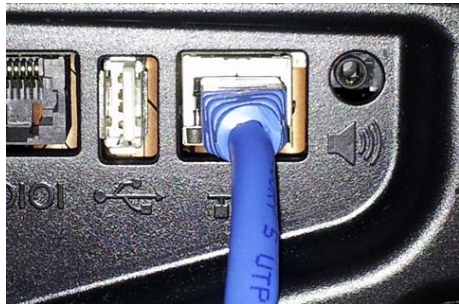

4.5.3 DC Power Supply

The low-voltage DC Cable is plugged into the correct connector on the rear of the G6 OPT:

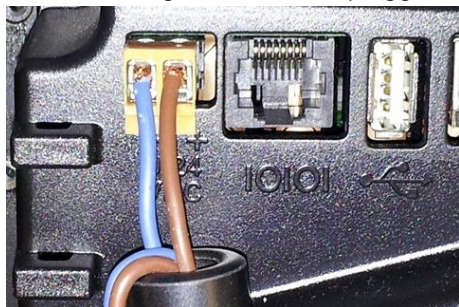

4.5.4 Main Power Supply Wiring

The other end of the low-voltage DC Cable is connected into the AC-DC power supply as below:

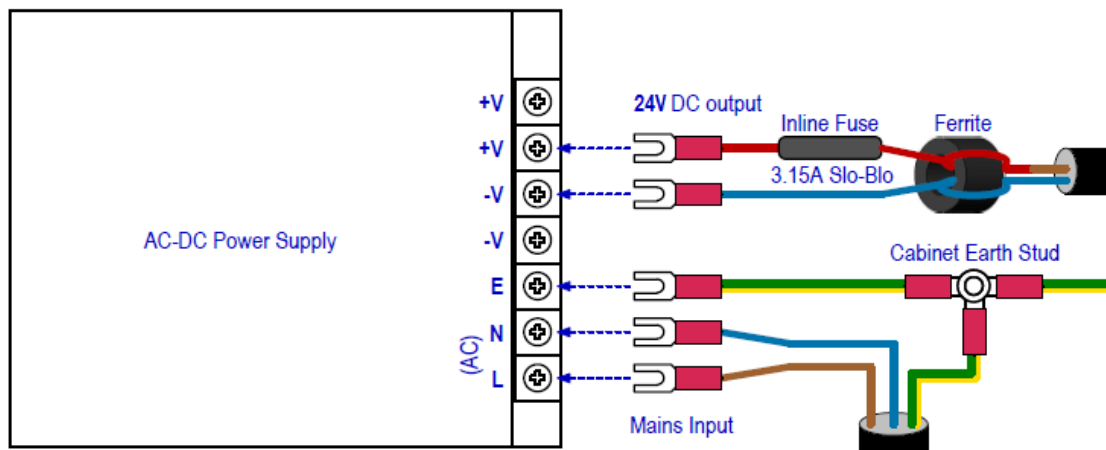

Note: If retrofitting in place of a G5 OPT, the power supply may be able to be re-used. In this case the old 24V DC cable that powered the G5 OPT must be disconnected and replaced with the new cable for the G6 OPT.

- ! **WARNING – Once all the wiring to the power supply terminals has been completed, install the terminal cover to prevent accidental contact with the live mains connections.**

4.5.5 Wiring Completion

When all the cables have been installed, use cable ties to provide strain relief. The rear of the G6 OPT has two plastic loops close to the connectors that are intended to assist with this. Also ensure that all cables are tidy and cannot become snagged or pinched when the door of the cabinet is opened and closed.

- ! **WARNING – Local regulations may also require that the installation is electrically tested and certified BEFORE switch-on.**

5 First Power-Up

Once the installation is complete and the wiring is certified (if necessary), the main power may be switched on.

The G6 OPT takes a couple of minutes to complete its start-up phase during which several information screens will be presented (these vary depending on the customer).

When the terminal is trying to connect to the Ethernet LAN it will display the following screen:



If the Ethernet LAN is not operational the terminal will keep the above screen displayed. If the terminal is successful in connecting to the Ethernet LAN it will display the following screen and the rest of the normal start-up sequence will continue (this also varies depending on the customer):



Follow the steps in Section 6.2 to load a fresh roll of paper.

6 Basic Maintenance

6.1 Cleaning

The G6 OPT is designed to be easy to keep looking good. Please follow these tips to keep your G6 OPT clean:

- Use a soft cloth dampened with water for daily cleaning.
- If grime builds up, use a diluted mild detergent on a soft cloth.
- Take extra care when cleaning the display window – make sure the cloth is clean and do the window before using the cloth on other parts of the terminal.
- **CAUTION** – Do NOT use petroleum-based solvent cleaners – they may damage surfaces making the terminal much harder to clean, and shorten the life of the parts.
- **CAUTION** – Do NOT use a high-pressure hose to clean the terminal. The printer chute and card reader openings will fill with water which will damage the terminal.

Over time the printer may accumulate dust and debris from the paper and cutting function. Please do not attempt to remove dust build-up from the printer – refer cleaning to a qualified service agent.







6.2 Paper-Roll Replacement (only for models with printer)

The G6 OPT has a precision printer mechanism that will give a long life when handled well. After extensive testing, Invenco recommends only the following paper be used in the G6 OPT:

Manufacturer:	NCR
Part Number:	020209
Paper Specification:	72GSM (74µm), Outdoor rated, Top-coated Thermal, 57mm wide.
Roll Size:	110mm dia, Core Hole size 12mm

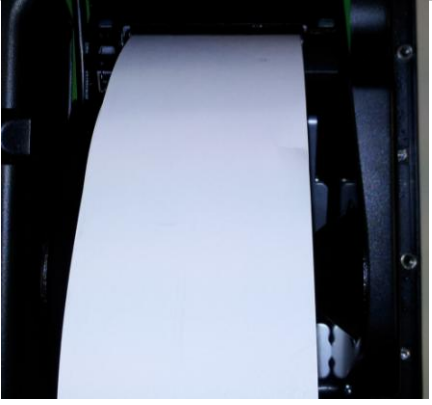
Follow the steps below to load paper into the G6 OPT. Use this full-view image as a guide:

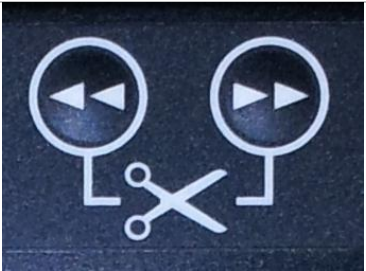



Step	Description	Photo reference
1.	Ensure the paper roll has a neat cut edge.	
2.	<p>Remove spindle from the paper holder position</p> <p>Insert roll in place – the paper tension flap is spring-loaded so you will need to apply some pressure.</p> <p>Insert the spindle through the middle of the roll to hold in place.</p>	
3.	<p>Insert the cut edge of the paper into the slot as shown in the photo opposite.</p> <p>Note: Insert until the printer grips and feeds automatically.</p>	
4.	The photo opposite shows the paper loaded.	
5.	<p>The photo opposite shows the feed button.</p> <p>Press either button   to move the paper forward or back.</p> <p>Press both buttons together to cut the paper.</p>	
6.	<p>Feed the paper through the terminal until it appears out the chute.</p> <p>Cut the paper using both feed buttons, and remove the cut length from the chute.</p>	

6.3 Clearing a Paper Jam (only for models with printer)

DO NOT use sharp tools (scissors, screwdriver, etc) to clear a paper-jam. The printer is a precision mechanism that can be easily damaged by hard sharp objects. Damage resulting from sharp objects is not covered under warranty.

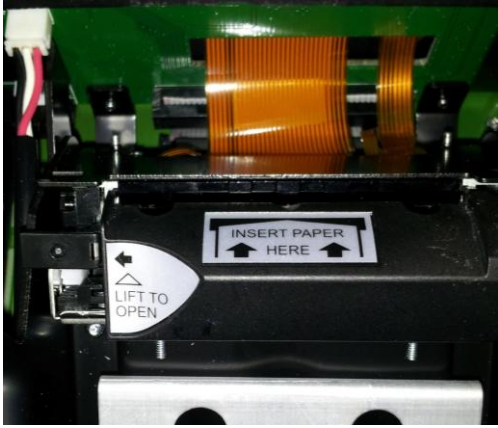
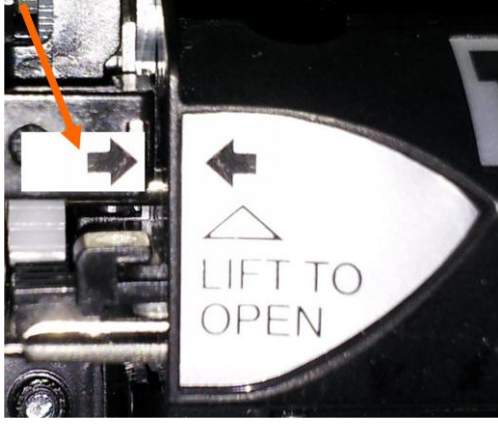
Follow the steps below to clear a paper jam.

Step	Description	Photo reference
1.	<p>Remove the paper roll if necessary. The photo opposite shows the paper controls.</p>	
2.	<p>Lift the lever beside the 'LIFT TO OPEN' flap. This will release the paper guide.</p>	
3.	<p>Any paper jammed will be visible behind the vertical slots of the paper roll holder. See photo opposite. Carefully remove any paper visible behind these slots.</p>	

4. Close the Printer.
Press the lever until the arrows are aligned.

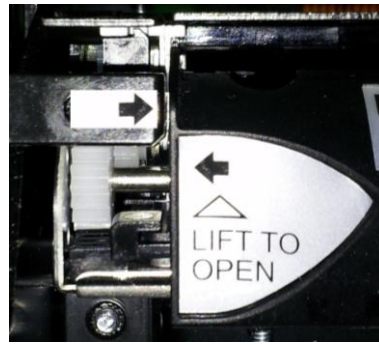

Printer unlatched

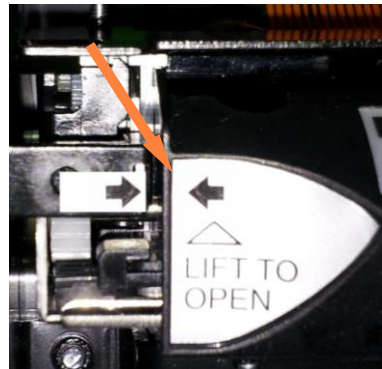

Arrows aligned

7 Removal & Reinstallation

If the G6 OPT needs to be removed from its installation, please follow these steps:

Step	Description
1.	Ensure the terminal is not being used by a customer.
2.	Open the pump/pedestal door.
3.	Reverse-feed the paper to extract it from the printer. Remove the paper roll from the terminal.
4.	Switch off the mains power to the power supply.
5.	Carefully cut the cable ties holding the cables to the G6 OPT. Any other cable ties should be left in place.
6.	Unplug the LAN cable and the low-voltage power cable from the G6 OPT. Remove the Ground wire.
7.	Loosen and remove the screws holding the G6 OPT to the door. There will be either - <ol style="list-style-type: none"> a. 12 screws around the outside of the rear plastics if the terminal was installed new, or b. 4 screws into a pair of adaptor brackets if it was a retrofit. The brackets can remain in place unless they cause interference, or if you need to replace them as well.
8.	There is a soft foam gasket that seals the G6 OPT to the outside face of the door, and over time this is likely to stick to the door. Use gentle hand pressure to push the G6 OPT off the door, while holding the terminal on the outside to prevent it falling.
9.	Place the G6 OPT into suitable packaging for transport or perform the necessary maintenance.
10.	If the sealing gasket was stuck to the door, clean off any pieces of gasket material with a soft scraper, being careful not to damage the door surface.

Follow the steps below to reinstall a G6 OPT:

Step	Description
1.	<p>If you are swapping one G6 OPT for another, proceed to step 2.</p> <p>To prepare the terminal, you will need to remove the existing sealing gasket and replace it with a new one.</p> <ol style="list-style-type: none"> The gasket is strongly fixed to the terminal and must be scraped off with a soft scraper. Use isopropyl alcohol to remove any remaining adhesive. Apply a new gasket by removing the THIN paper backing and carefully positioning it over the G6 OPT rear cover. Align the gasket before pressing down gently all around. Gently remove the cardboard backing just before you reinstall the terminal.
2.	Place the G6 OPT carefully into the cut-out in the door, and align it with the screw-holes or with the brackets if this is a retrofit.
3.	Start the screws into the G6 OPT but don't tighten them.
4	<p>Make sure the G6 OPT is properly aligned, and then tighten the screws.</p> <ol style="list-style-type: none"> If this is a retrofit and you are reinstalling the brackets, press the G6 OPT onto the door before tightening the screws, to ensure a good seal. If this is a retrofit and you are only replacing the G6 OPT, make sure the terminal is not twisted in the cut-out, and lines up with external features of the door/pump before tightening the screws.
5	Plug in the LAN cable and the low-voltage power cable, and reconnect the Ground wire.
6.	<p>Use new cable ties to secure the cables to the G6 OPT.</p> <p>Ensure that the cables are tied so that they will not be snagged or pinched when the door is opened and closed.</p>
7.	Switch on the mains power supply and check that the G6 OPT powers up correctly.
8.	Replace the paper roll in the G6 OPT and feed the paper into the printer.
9.	Check that the G6 OPT has come online correctly, and then close the door.

8 Drawings

8.1 Dimensions

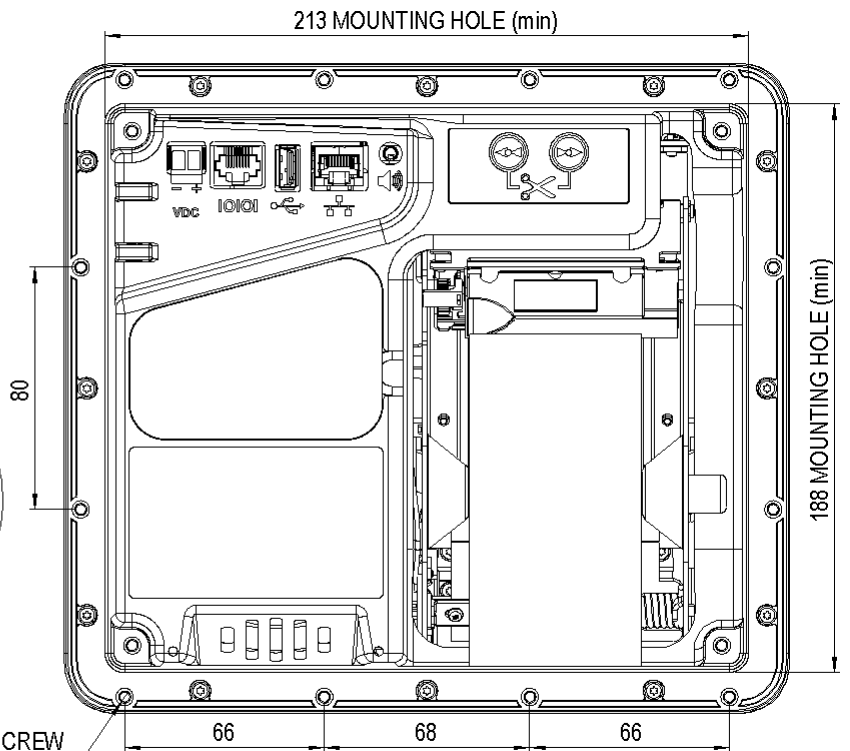
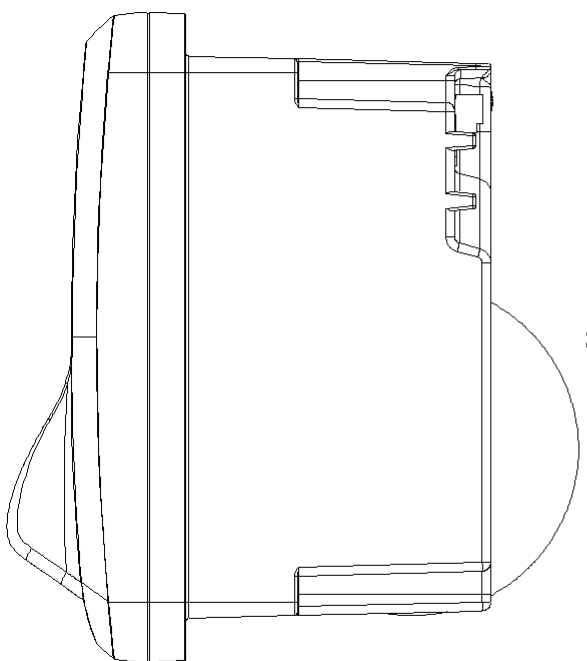
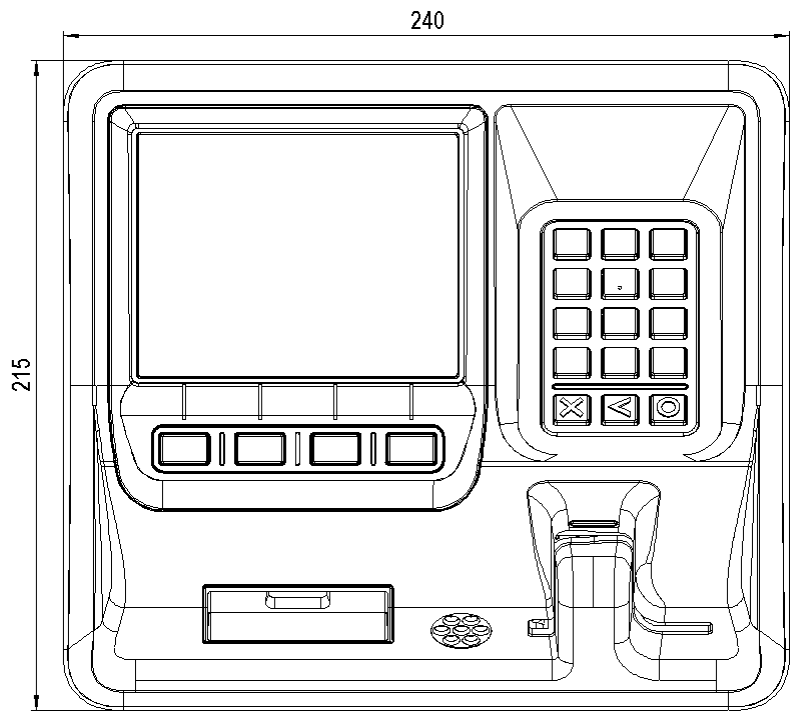
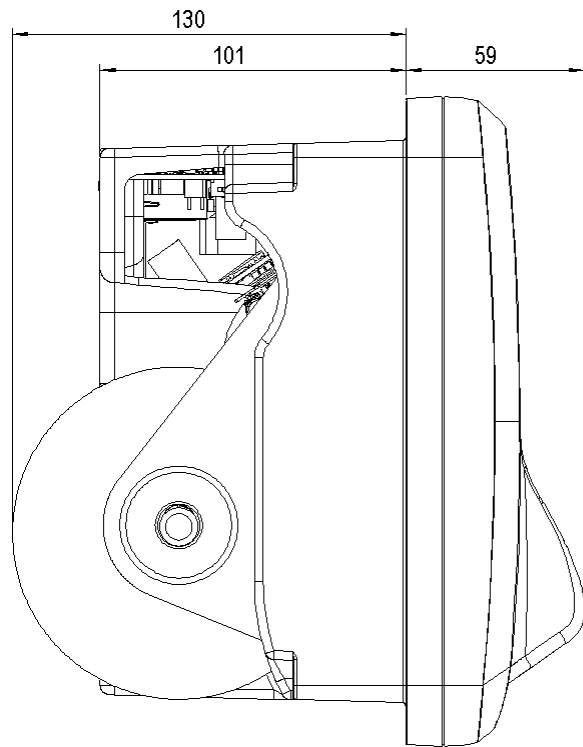

12 X MOUNTING SCREW LOCATIONS \varnothing M4

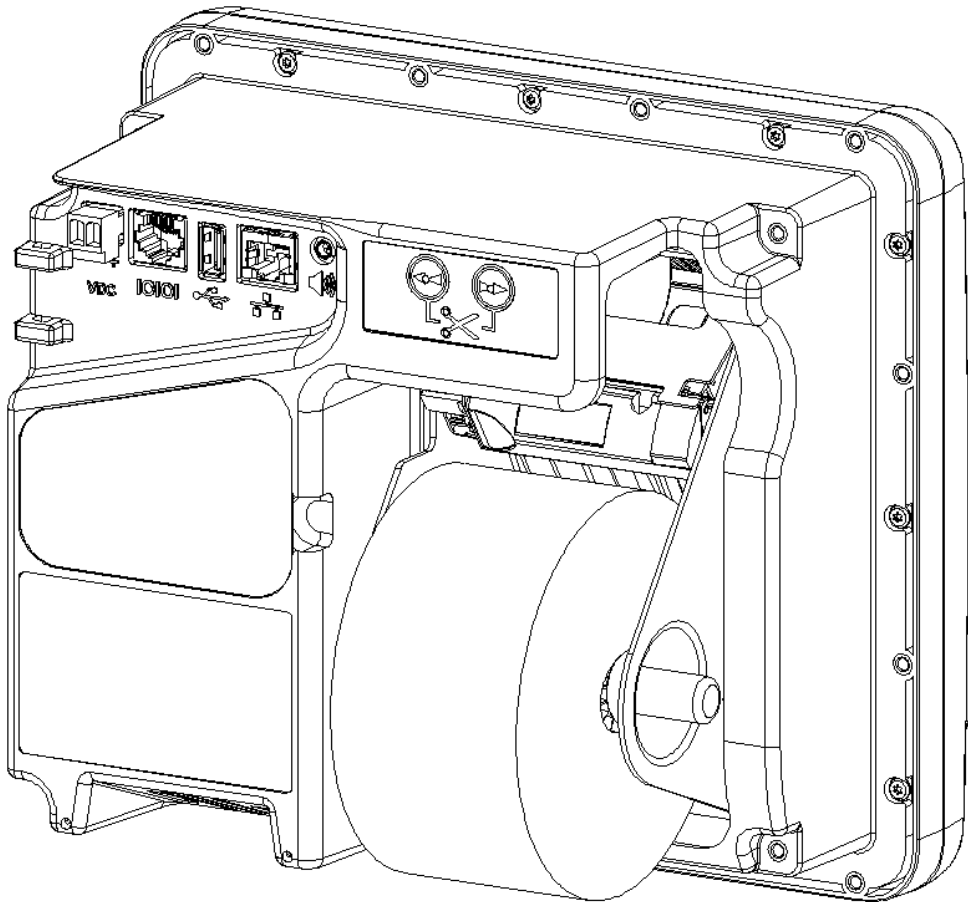
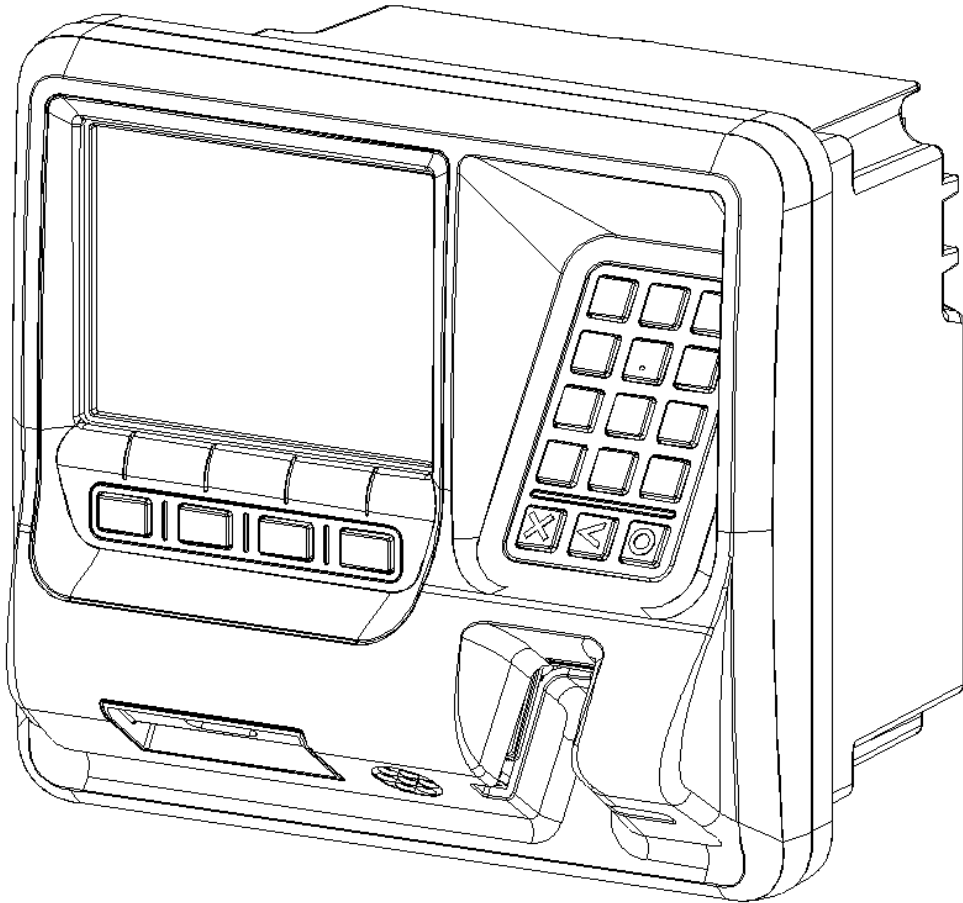

8.2 Mounting – New Installation

Note: This drawing is not to scale – **Do NOT** use as a template.

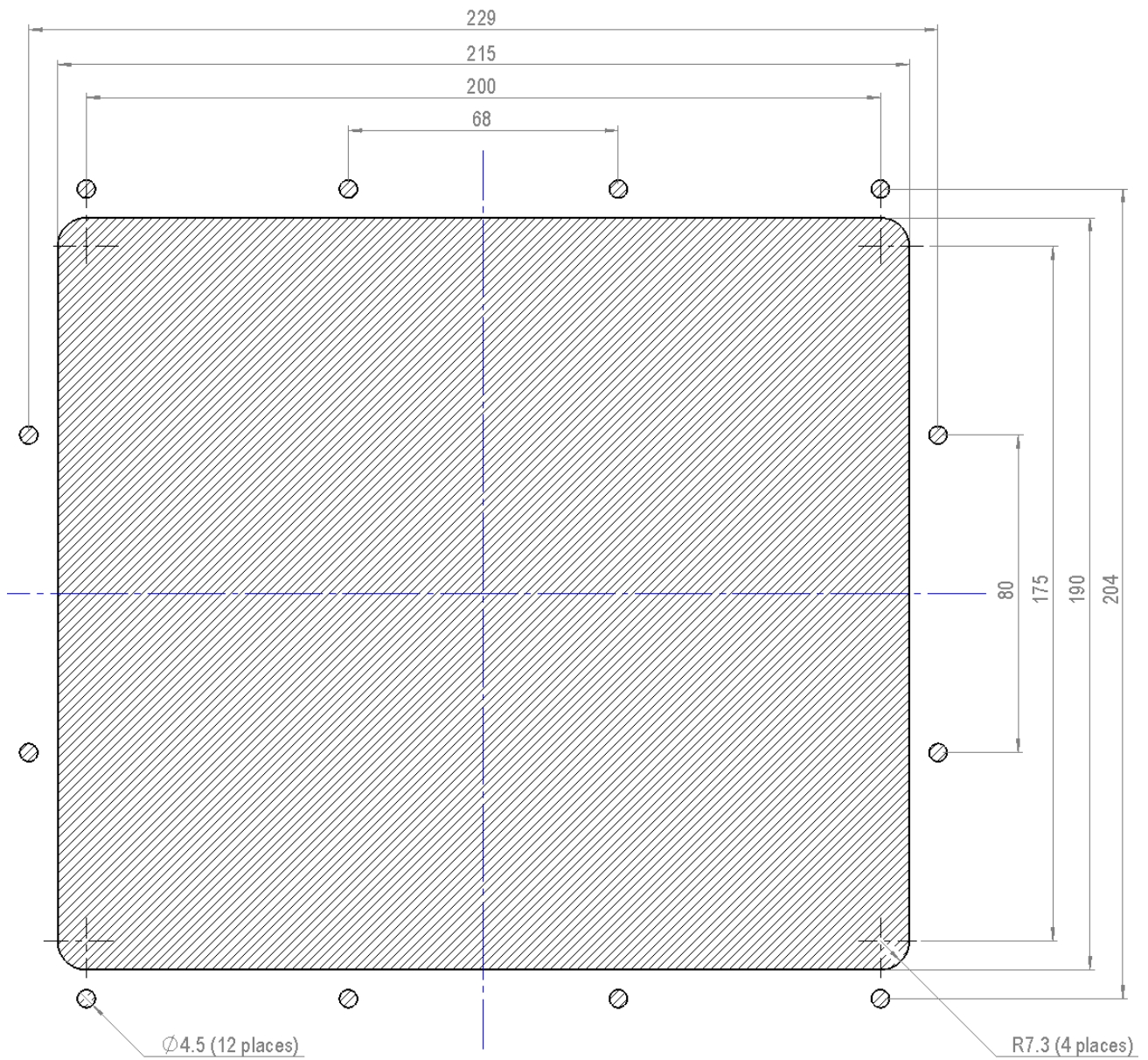

ITEM NO.	PART NUMBER	DESCRIPTION	Back Mount/QTY.
1	EZ0091 (OPT)	OPT MAIN ASSY	1
2	MP0148	MOUNTING GASKET	1
3	DI0004 (Mounting Holes)	Cutout in Pump Door	1
4	MS0031	SCREW, M4 X 7, PAN HEAD, MACHINE, TORX T20	12

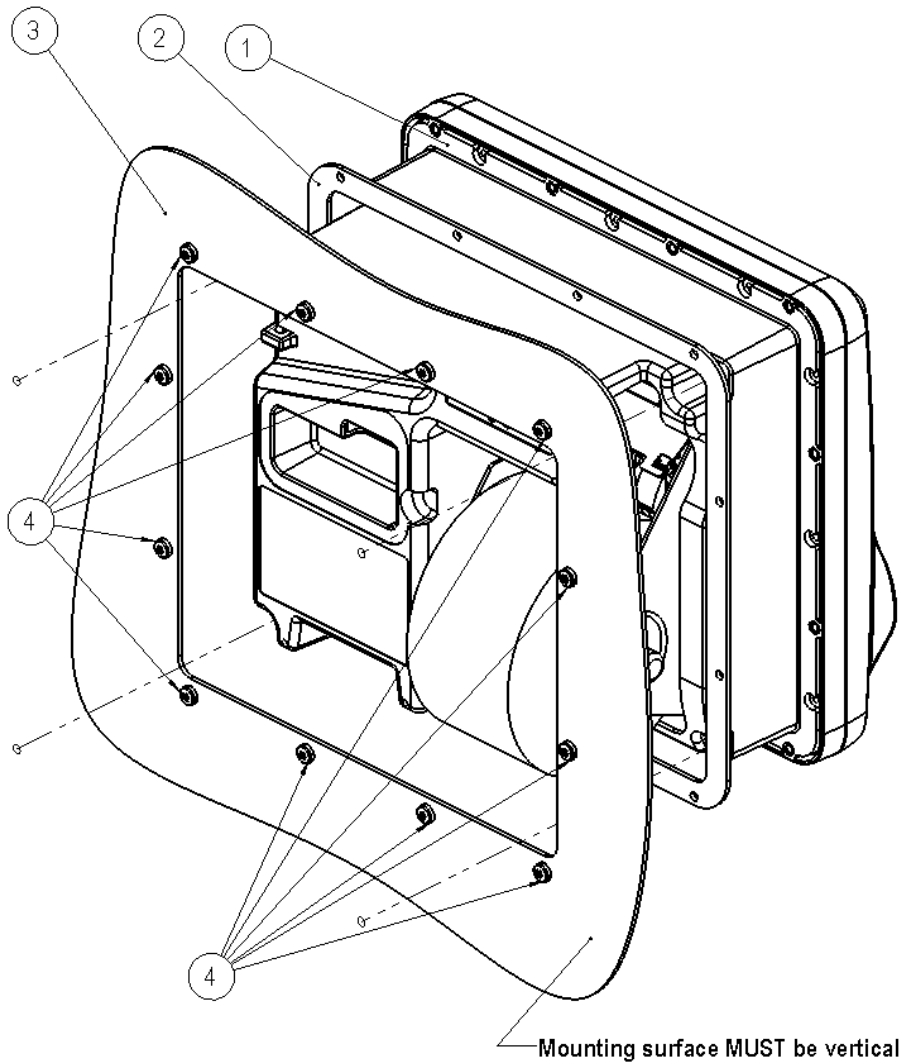

8.3 Retrofit for G5 OPT with Motorised Card Reader

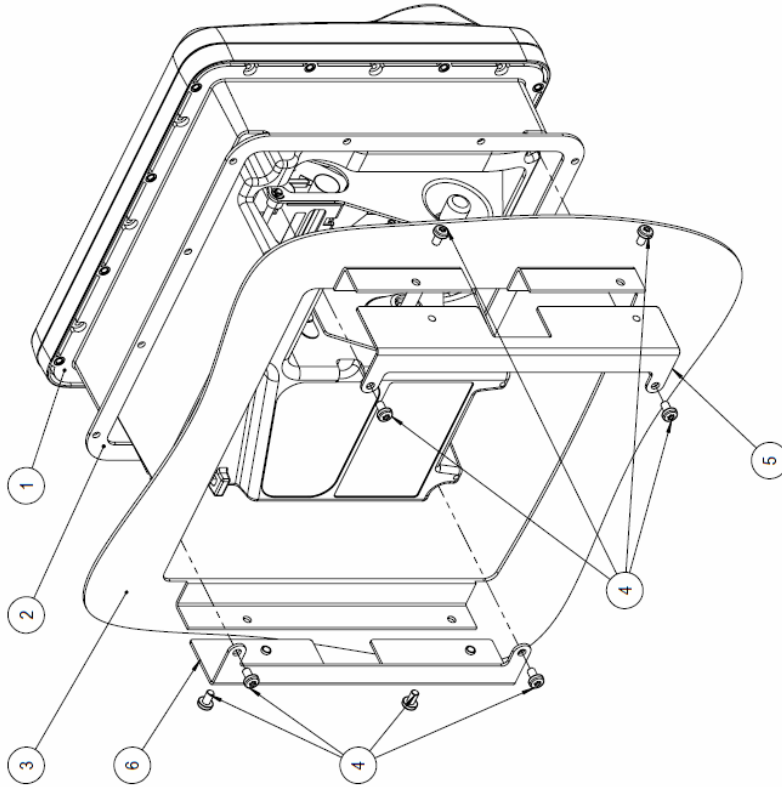

ITEM NO.	PART NUMBER	DESCRIPTION	Side Mounting/QTY.
1	EZ0091 (OPT)	OPT MAIN ASSY	1
2	MP0148	MOUNTING GASKET	1
3	DI0004 (Mounting Holes)	Cutout and mounting in existing pump	1
4	MS0031	SCREW, M4 X 7, PAN HEAD, MACHINE, TORX T20	8
5	MP0147	RIGHT SIDE MOUNTING BRACKET	1
6	MP0146	LEFT SIDE MOUNTING BRACKET	1

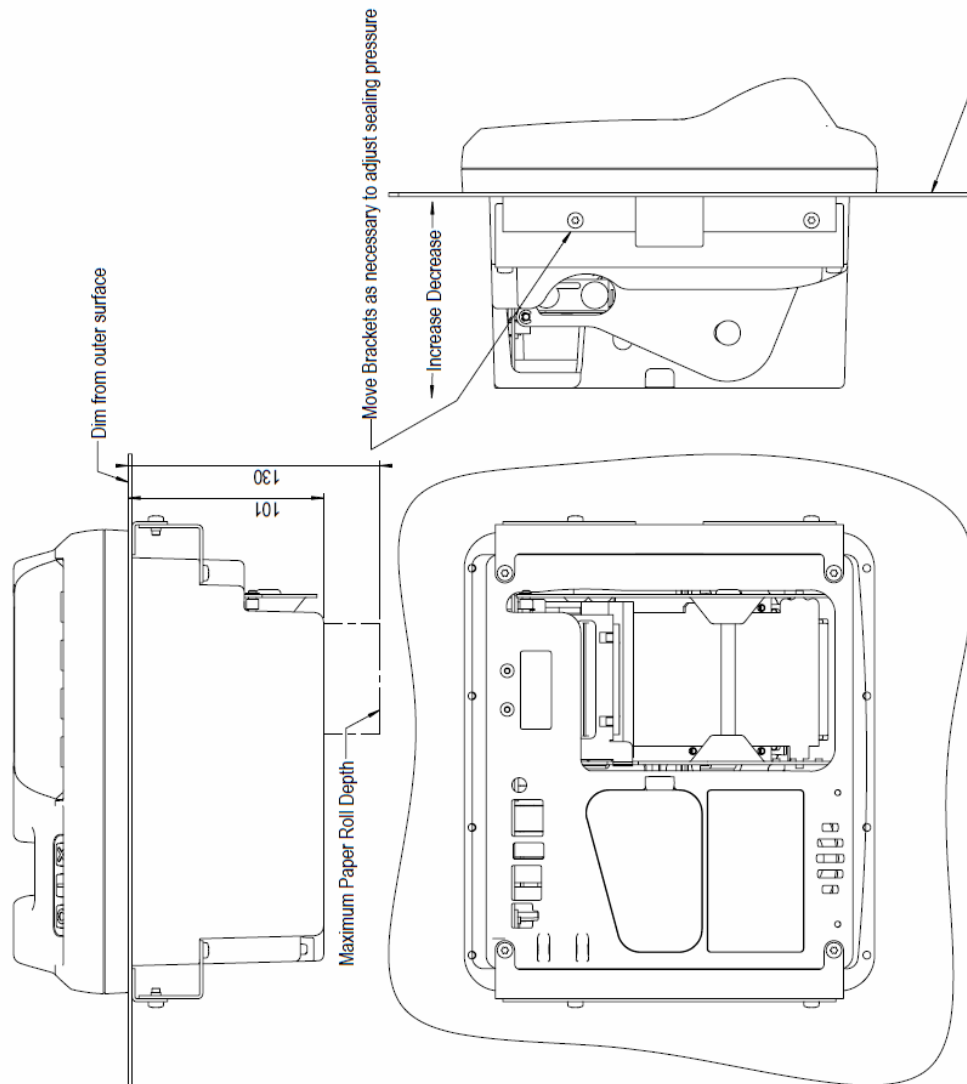

1. Screw Left (9) and Right (8) mounting brackets using four M4x7 screws (6) but do not tighten.
2. Slide Mounting Gasket (2) over the OPT (1).
3. Screw OPT (1) onto Left (9) and Right (8) mounting brackets using four M4x7 screws (6) but do not tighten.
4. Check alignment of OPT in existing cutout. Also check that the OPT will seat firmly against the pump door.
5. If necessary, adjust the Left and Right mounting bracket positions toward the rear of the slots in the existing mounts before tightening.
6. Finally, tighten the OPT mounting screws to pull the OPT tight against the pump door.

8.4 Retrofit for G5 OPT with Manual Card Reader

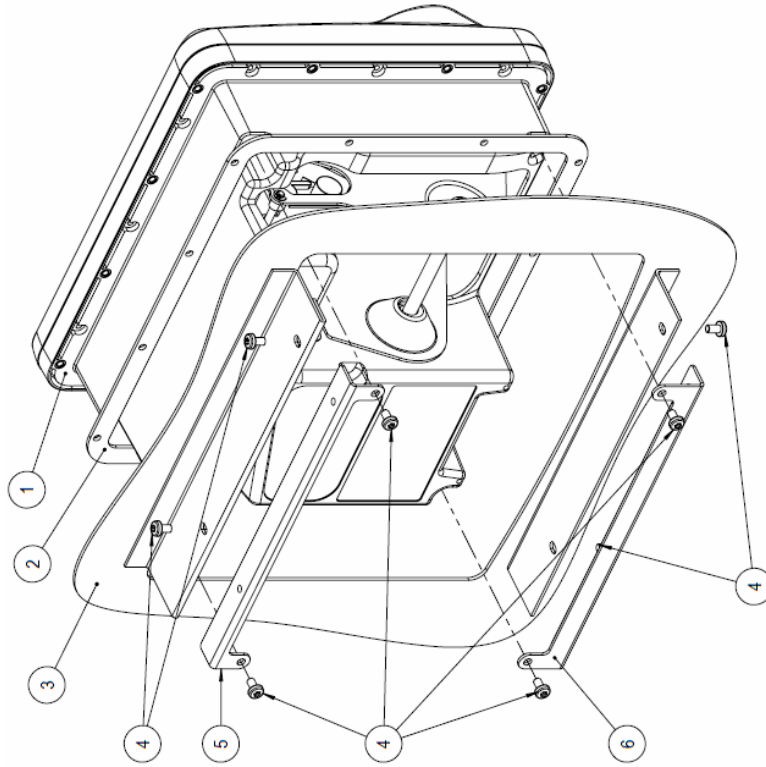

ITEM NO.	PART NUMBER	DESCRIPTION	Top and Bottom Mounting/QTY.
1	EZ0091 (OPT)	OPT MAIN ASSY	1
2	MP0148	MOUNTING GASKET	1
3	D10004 (Mounting Holes)	Cutout and mounting in existing pump	1
4	MS0031	SCREW, M4 X 7, PAN HEAD, MACHINE, TORX T20	8
5	MP0136	TOP MOUNTING BRACKET	1
6	MP0137	BOTTOM MOUNTING BRACKET	1

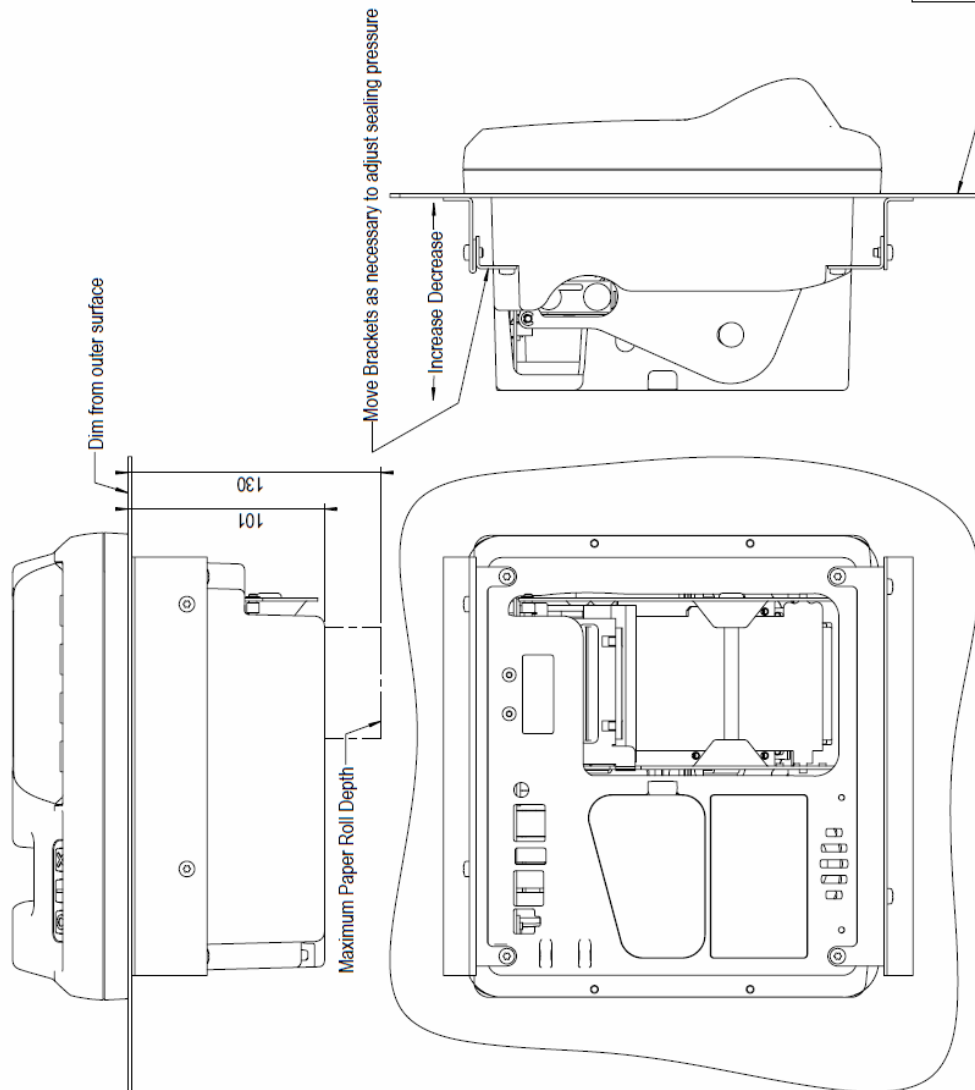

Mounting surface **MUST** be vertical

1. Screw Top (4) and Bottom (5) mounting brackets using four M4x7 screws (6) but do not tighten.
2. Slide Mounting Gasket (2) over the OPT (1).
3. Screw OPT (1) onto Top (4) and Bottom (5) mounting brackets using four M4x7 screws (6) but do not tighten.
4. Check alignment of OPT in existing cutout. Also check that the OPT will seat firmly against the pump door. If necessary, adjust the Top and Bottom mounting bracket positions toward the rear of the slots in the existing mounts before tightening.
5. Finally, tighten the OPT mounting screws to pull the OPT tight against the pump door.
- 6.

9 Typical Wiring

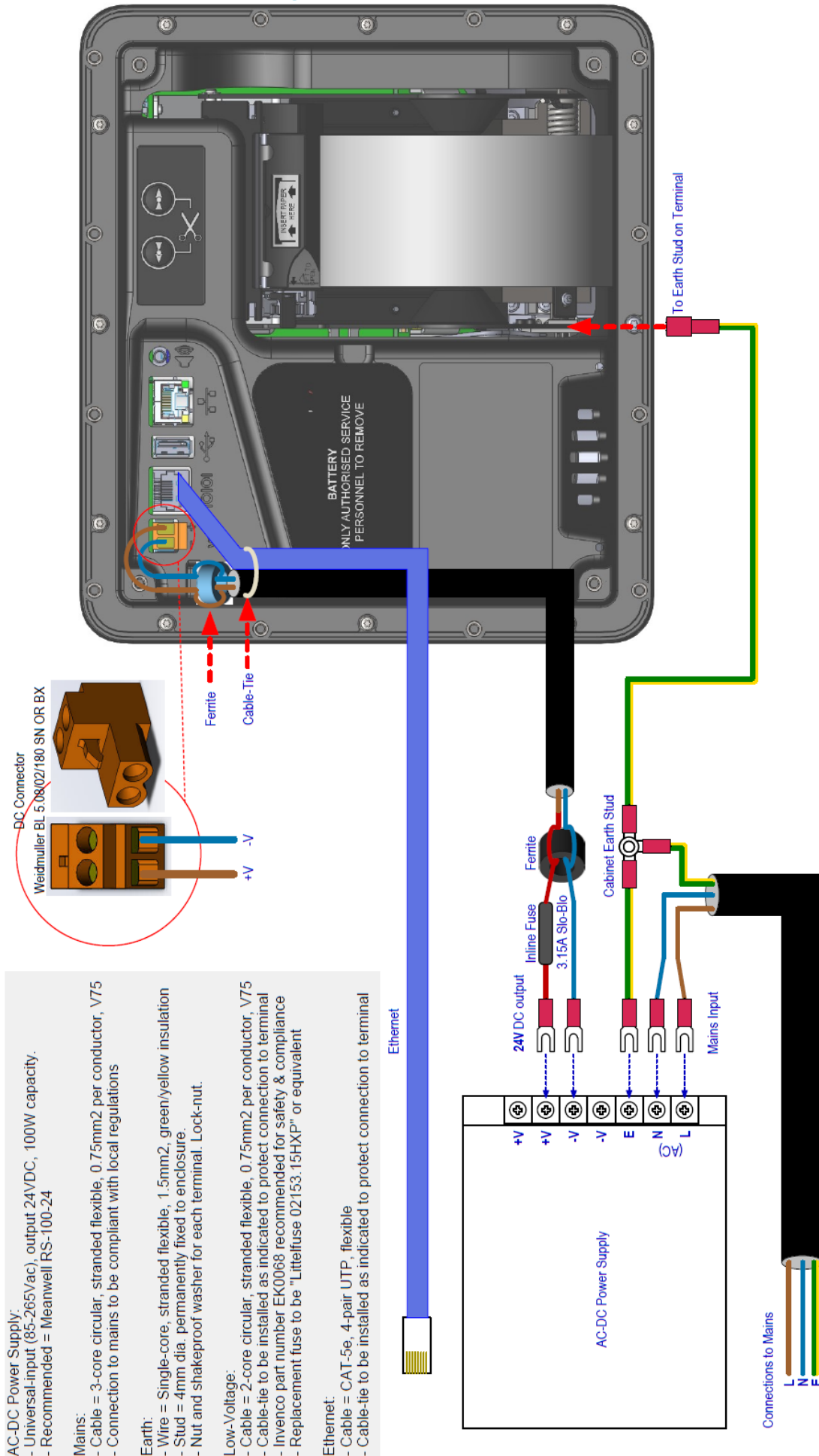

- AC-DC Power Supply:**
- Universal-input (85-265Vac), output 24VDC, 100W capacity.
 - Recommended = Meanwell RS-100-24
- Mains:**
- Cable = 3-core circular, stranded flexible, 0.75mm² per conductor, V75
 - Connection to mains to be compliant with local regulations
- Earth:**
- Wire = Single-core, stranded flexible, 1.5mm², green/yellow insulation
 - Stud = 4mm dia. permanently fixed to enclosure.
 - Nut and shakeproof washer for each terminal. Lock-nut.
- Low-Voltage:**
- Cable = 2-core circular, stranded flexible, 0.75mm² per conductor, V75
 - Cable-tie to be installed as indicated to protect connection to terminal
 - Invenco part number EK0088 recommended for safety & compliance
 - Replacement fuse to be "Littelfuse 02153.15HXP" or equivalent
- Ethernet:**
- Cable = CAT-5e, 4-pair UTP, flexible
 - Cable-tie to be installed as indicated to protect connection to terminal

Weidmuller BL 5.08mm pitch 2-way; Part Designation: BL-5.08-2-SN-OR; Order No: 1716320000

10 Notes

Auckland

Ph: + 64 9 369 2900
111 Franklin Rd
Freemans Bay
Auckland 1011
New Zealand

Asia

Ph: +60 3 2785 1888
Suite 2B-1-1, Level 1, Block 2B
Plaza Sentral
Jalan Stesen Sentral 5
50470 Kuala Lumpur
Malaysia

© 2015 Invenco Group Ltd. All rights reserved.

No part of this document may be copied or reproduced in any form without prior written consent of Invenco Group Ltd.

The information in this document is subject to change without notice and should not be construed as a commitment by Invenco Group Ltd. Invenco Group Ltd has taken great effort to verify the accuracy of this document but assumes no responsibility for any technical inaccuracies or typographical errors.