



User's Manual



**Fixed RFID Reader
XCRF-860**

www.invengo.cn

**Thank you for your use of RFID Reader XCRF-860 from
Invengo Information Technology Co., Ltd.**

NOTE:

**THE MANUFACTURER IS NOT RESPONSIBLE FOR ANY
RADIO OR TV INTERFERENCE CAUSED BY
UNAUTHORIZED MODIFICATIONS TO THIS EQUIPMENT.
SUCH MODIFICATIONS COULD VOID THE USER'S
AUTHORITY TO OPERATE THE EQUIPMENT.**



Preface

This User's Manual applies to:



Fixed RFID Reader XCRF-860

This manual provides the information on the product's installation, operation, maintenance and repair and other features, for the personnel installs, operates and maintains this product.

This manual's version is V1.4, printed on **/**/**** (MM/DD/YY).

Revision history:

Mar. 03, 2008	Initial Version V1.0
Mar. 17, 2008	First Revision V1.1
Apr. 08, 2008	Second Revision V1.2
Apr. 14, 2008	Third Revision V1.3
May 13, 2008	Fourth Revision V1.4

Both  and  are the logs of Invengo.

Important Information and Disclaimer: The information provided on this User's Manual represents Invengo's knowledge

and belief as of the date that it is provided, and all the information in this User's Manual are believed to be accurate and correct. In a continuing effort to improve our products, Invengo reserves the right to change specifications and instructions without prior notice.

Invengo reserves the right to make changes without notice to any products herein for any reason at any time, including but not limited to improving the reliability, form, fit, function or design.

For more information, please contact Invengo at:

86-0755-26711633 (Shenzhen China)

65-67960366 (Singapore)

1-703 793 0085 (USA)

Safety Instructions



Warning

Personal injury may be caused in the case of incorrect operation.

The equipment may be susceptible to damage if incorrect operation is performed.



Notice

Your operation may not be performed successfully by negligence of the instructions.

Unexpected result may be caused by negligence of the instructions.

Table of Contents

1	Package and Unpacking Inspection.....	1
1.1	Package.....	1
1.2	Unpacking.....	1
2	Attentions to use.....	2
2.1	Model and Specification.....	2
2.2	User Environment.....	2
2.3	Safety Instructions.....	3
3	Installation and Commissioning.....	4
3.1	Conditions of Installation.....	4
3.1.1	Choosing an Installation Location.....	4
3.1.2	Checking the Operating Configuration.....	5
3.2	Installation Procedure.....	5
3.2.1	Fixing the XCRF-860 Reader.....	5
3.2.2	Connecting the XCRF-860 to Other Equipments.....	5
3.2.3	External AC Power.....	7
3.2.4	Configuring Antenna.....	8
3.3	Common Faults in Commissioning.....	8
3.4	Attentions to install.....	10
4	Performance Specifications.....	11
4.1	Main Functions.....	11
4.2	Technical specifications.....	11
4.3	Dimensions and Weight.....	12

5	Structure Characteristics.....	12
5.1	Back and front panels	13
5.1.1	Front panel	14
5.1.2	Back panel	14
5.1.3	Top panel	17
5.1.4	Bottom panel	17
5.2	The Internal Structure and the Modules.....	18
5.2.1	Power Unit.....	18
5.2.2	Data Interface Unit	18
5.2.3	Cabinet.....	19
5.3	Auxiliaries.....	19
5.3.1	PC	19
5.3.2	RF Cable	19
5.3.3	Reader Interface Software	20
5.3.4	Antenna.....	20
5.3.5	Communication Cable	20
6	Operation Instructions.....	21
6.1	Application environment Demo Software	21
6.2	Initiating of Demo Software	21
6.3	Complementary tool for XCRF-860 Demo Software	
	Source	24
6.4	Reader Configuration	24
6.5	Operation Instructions on Demo Software	29
6.6	Common Faults and Troubleshooting	33
7	After-sale Service and Contact Information	35

7.1	After-sale Service.....	35
7.1.1	The Reader	35
7.1.2	PC	35
7.2	Contact Information.....	35
7.3	Other Issues	36

1 Package and Unpacking Inspection

1.1 Package

XCRF-860 reader is packed with a color box, and suitable for large transportation turnover tank.

1.2 Unpacking

Save the XCRF-860 and shipping material in case you need to ship or store the XCRF-860.

The items in the package include:

Fig. 1-1 The Packing List

No.	Item	Unit	Quantity	Note
1	XCRF-860	Unit	1	
2	3-core Power Cable	Piece	1	
3	RS-232 Cross Cable (1.5m)	Piece	1	
4	Cross Network Cable	Piece	1	
5	USB2.0 cable (1.5m) with two A type male connectors	Piece	1	
6	RF (N-SMA) Cable	Piece	4	
7	CD-ROM	Disk	1	
8	Certificate of Qualification	Sheet	1	
9	Warranty Card	Sheet	1	
10	User's Manual	Copy	1	



Please check if the items are complete by the packing list, and contact us in time if any discrepancy or damage occurs.

2 Attentions to use

2.1 Model and Specification

The Fixed RFID Reader XCRF-860 from Invengo is the latest member of a product family, including XCRF-860, XCRF-804, XC2800, XCRSF-800 series reader modules and XCRF-804 (EU edition), that can operate with either ISO18000-6B, ISO18000-6C (Gen2) or both.

This User's Manual applies to XCRF-860.

2.2 User Environment

A complete RFID data collecting system (consisting of reader, electronic tag, PC/s and reader interface software) is essential to XCRF-860 reader's operation.

Please assure that all the components constituting a RFID data collecting system are complete, before use of XCRF-860. Assure that all components are connected according to the instructions.

The requirements of XCRF-860 reader on its working environment are as follows:

- ☞ Temperature range:
-20°C ~ +55°C (-4°F ~ +131°F)

☞ Humidity range:

20%~95%

☞ Power voltage:

AC: 100V to 240V/50Hz to 60Hz

2.3 Safety Instructions

The power range for this equipment is AC 100V to 240V/60Hz. Please assure that the power requirement is met prior to the installation and operation!



The installation and commissioning personnel must keep a minimum distance of 30cm away from the reader while it is operating (radiating microwave power), so as to provide appropriate protection against harmful interference in an installation in accordance with FCC regulations on the limits of radio frequency (RF) radiation exposure for human body.

The instruction is intended for site installation and commissioning of this equipment.



Radio transmission equipments, including this reader, may cause disturbance to the performance of the medical equipments that have no proper protection. You may consult the manufacturers of such medical devices to prevent such event from occurring. This equipment may

also cause disturbance to other electronic equipment during the operation.

3 Installation and Commissioning

3.1 Conditions of Installation

Before installing XCRF-860, please assure that this equipment is in good condition, and that the accessories are complete; please timely contact local suppliers for replacement, if any damage or shortage. In addition, assure that the following installation requirements are met.

- ✧ Conform to the requirements of working environment;
- ✧ The required accessories are complete and of the specified standards, for constituting a complete reader application environment.

3.1.1 Choosing an Installation Location

XCRF-860 can be installed either on desktop or wall mounted depending on the different application environments.

Select the installation locations according to installation requirements. Generally, the reader must be installed in a location where is safe and convenient for operation.



To comply with RF radiation exposure requirements, the antenna/s for XCRF-860 reader must be installed with

appropriate separation distance between all persons and the antenna.

3.1.2 Checking the Operating Configuration

If the network communication mode was selected, configure the network via the serial port and check if there is any mistake before installation (No collision between IP and other devices in the same network segment).

3.2 Installation Procedure

3.2.1 Fixing the XCRF-860 Reader

Following are two methods to fixing the XCRF-860 reader depending on the installation location:

1. **Mounting on Desktop**

XCRF-860 reader is horizontally placed on a desktop.

2. **Mounting to a Wall**

Fix XCRF-860 reader on a vertical surface with its 4 installation ports. The fixing method: insert expansion bolts into a vertical surface (a wall or side face of a rainproof box); or fix the reader with bolts and nuts.

3.2.2 Connecting the XCRF-860 to Other Equipments

Connect the reader to antennas and PC.

1. **Connecting to External Antennas**

The 4 SMA ports for coaxial cable are on the back panel of XCRF-860 reader for connecting the reader to external antennas. Low-loss RF cable is used as the connection cable. Tightened connections are required among cable, antenna and the reader.

2. Installing External Antennas

The external antennas of XCRF-860 readers are usually installed outdoors. The beam coverage is the effective range of reading and writing electronic tags by the system.

The external antennas can be installed in a horizontal top-mounting way (the gantry of a vehicle channel) or a vertical side-mounting way (pillar mounted). Adjust the antennas' positioning (inclination or rotation) to achieve the optimum position through read/write test.

Antennas of various specifications can be configured to XCRF-860 reader according to application requirements.

Linear polarized antennas are recommended for XCRF-860 reader (to eliminate the decrease of antenna gain). During on-site installation, polarization matching of the reader's antennas and the electronic tags' antennas should be considered; neglecting this factor results in the affected reader's read/write distance to the electronic tags.

3. Connecting to PC

XCRF-860 reader offers RS-232 serial port, USB port, and Ethernet port.

The serial port is used for a short-distance connection (less than 5m), and the RS-232 serial connector shall be connected to PC via a piece of 1.5 m dedicated cable that comes with standard delivery.

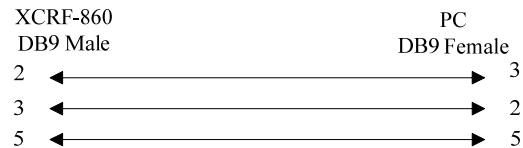

Fig.3.1 XCRF-860's connections to RS-232 port via the dedicated cable

The network port is used for a long-distance high-speed connection (up to 100m).The network port can be connected to the switch or the concentrator via the network cable, or directly connected to the network port of PC.

3.2.3 External AC Power

Connect XCRF-860 reader to the external AC power supply. The steps include:

1. Assure that the AC power's voltage and operating frequency are of AC100V - 240V/50Hz;
2. Assure that XCRF-860 reader's switch is "Off" ;
3. Connect one end a power cable with the AC power's socket, and then connect the other end with XCRF-860 reader's 3-core AC power input port;
4. Turn on the power switch on XCRF-860 reader's front panel; the power supply indicator lamp will be on after the reader

emits a notice sound, which indicates that the reader is initializing; after the initialization, the reader is on standby.



The XCRF-860 reader will go on standby status after power on. The reader does not emit during initializing or on standby status (RF power is off); its power amplifier will turn on only if it is connected to an antenna or a load and receives the instruction of “Read and Write Tag” or “Power Amplifier On” from the PC.



The reader may be susceptible to damage if Power on amplifier without an antenna connection or without a dummy load.

3.2.4 Configuring Antenna

The reader's read/write range can be preliminarily decided according to the site application. Select an installation location of an antenna. Fix the antenna and adjust its inclination (striking) angle through XCRF-860 reader's read test, to achieve the optimum position for best read performance.

Finally, Install the antenna and fix the inclination (striking) angle.

3.3 Common Faults in Commissioning

The common faults during commissioning are described in details in this section, including the general faults resulted from incorrect installation, and the solutions.

The common faults during commissioning are as follows:

- The reader does not response

- ☆ Indicator lamps off → check the power supply;

- ☆ The indicator lamp for power supply is on → Check cable connections, and check corresponding items by the relevant indicator lamps' status;

- ☆ In the status of network port communication → Check if the connected IP is correct; And check if any collision to the IP address;

- In serial port communication status → if the application software's ports and communication rates are correctly configured; Check if the antenna port configuration is correct.

- Read/write error

- ☆ Check if reader configuration on the application software is correct;

- ☆ if the reader is compatible to the tags;

- ☆ Are tags positioned within the effective read range of XCRF-860 reader?

- ☆ if electromagnetic interference between readers or other devices occur;

- ☆ if access passwords are required, and if they are correct;

- ☆ if the tags are damaged.
- The read/write range does not meet the requirements:
 - ☆ The positioning of the antennas;
 - ☆ If any interference exists on site.

3.4 Attentions to install

To guarantee personal and property safety, the following preparations must be performed before installing and operating the XCRF-860 reader:



Check the performance of the power plug, and if the power supply conforms to the power requirement of the reader.



Equipments should be connected to ground!



The installation location must be damp proof and have sunscreen, and be well-ventilated;



The distances between the equipments and the system (e.g. the reader and the antennas, the reader and the PC, and the reader and the power plug) must be measured and estimated;



Check if the installation locations and directions of the reader and the antennas result in signal interference to data transmission between the reader and the tags;



The length limits to the serial port cable and the network cable and the selection of network cable (through line and cross line) should be observed.



The equipment must undergo status test prior to installation and operation;



During installation and collocation of multiple readers, the positioning and the minimum distance between antennas of multiple readers should be observed in order to avoid interference.

4 Performance Specifications

4.1 Main Functions

Air interface protocol: ISO18000-6C

Tag data rate: 62.5kbps

Number of antennas: maximum 4, controlled by electronic switches

Isolation between antennas: $\geq 22\text{dB}$

Modulation mode: ASK, PR-ASK

Available frequency points: 50

Emission bandwidth: $< 400\text{kHz}$

4.2 Technical specifications

Operating Frequency: 902 to 928MHz

RF output power: 1.0W (+30dBm)

Frequency stability: $\leq \pm 5$ ppm

Operating mode: fixed frequency/frequency hopping
(optional)

Maximum read distance: 4 m (combined with Invengo antenna XCAF-11L)

Maximum write distance: 2m

Multi-tag reading rate: ≥ 60 per second (depending on protocols)

4.3 Dimensions and Weight

Dimensions of the XCRF-860 Reader:

300 x 210 x 70mm / 12.4 x 8.7 x 2.9(in)

Weight of XCRF-860:

2.2kg (4.8lb)

5 Structure Characteristics

XCRF-860 reader consists of the RF unit, the baseband unit, the power unit, the data interface unit and the cabinet. As illustrated in Fig. 5.1:

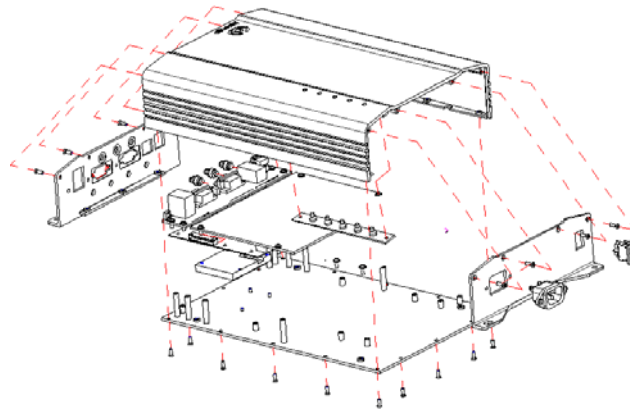

Fig.5.1 Structural Drawing of the XCRF-860 Reader

The XCRF-860 reader and antenna, tag and computer form a complete RFID application system. The reader executes the instructions from PCs and transmits energy and commands to the tags, while the tags use that energy to talk back (backscatter reflection) to the reader. The RFID tags can power itself with the induced current, and its backscatter is a pulse-width modulated (PMW) response. The PWM signal can be interpreted as a digital of ones and zeros.

RF block generates, modulates, amplifies and emits the carrier frequency; Reception block is designed for signal modulation, amplification and comparison.

MCU enables the communication with the PC.

5.1 Back and front panels

The Front and Back Panels, LEDs and Ports

5.1.1 Front panel

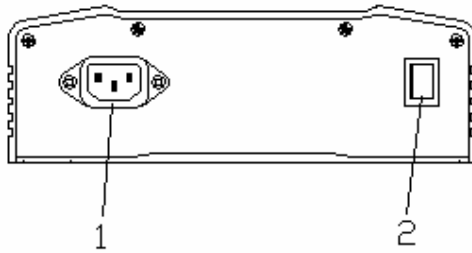

Fig. 5-2 The Front Panel of XCRF-860 Reader

- 1 – AC electric outlet;
- 2– Power switch.

5.1.2 Back panel

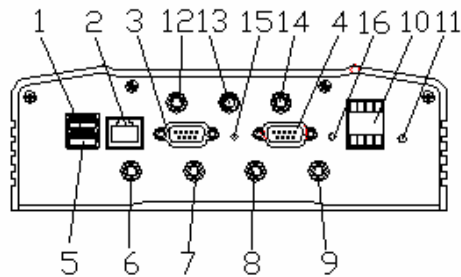

Fig. 5-3 The Back Panel of XCRF-860

- 1 – Main USB interface (for future use)
- 2 – Network port is a RJ-45 port, for data transmission to and from PCs or equipments; the data rate of the network port is 10/100Mbps (adaptive);

3 – RS-232 serial port, for data transmission to and from PCs or equipment; Its pin numbers, signal names and signal flow directions are shown in table below, of which the pin numbers are identical with the numbers marked on DB9 plug.

Pin Number	Signal Names	Signal Flow Direction
2	RXDRXD	Input
3	TXDTXD	Output
5	GndGnd	Grounding

4 – Connector is only available for serial communication debugging.

5 – Secondary USB interface, for data transmission to and from PCs or other equipments.

6 – Antenna port 1;

7 – Antenna port 2;

8 – Antenna port 3;

9 – Antenna port 4;

10 – IO control interface;

11 – Rest key;



USB communication should be disconnected after the Reset of XCRF-860!

12 – Bluetooth interface;

13 – WIFI Interface;

14 – GPRS Interface;

15 – Lamp of WIFI;

 **Port 12, 13 and 14 are only available for Enhanced Edition of the XCRF-860.**

16—Lamp of L1.

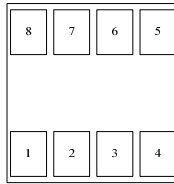

5.4 – IO control interface

- 1 – 5v power supply, (maximum current 200mA)
- 2 – Input port 1;
- 3 – Input port 2;
- 4 – Gnd Grounding;
- 5 – Output port 1;
- 6 – Output port 2;
- 7 – Output port 3;
- 8 – Output port 4;

Note: Low electrical level: the input and output voltage of IO control interface respectively are 0V; high electrical level: +3.3V

 **There are four antenna ports available on the Back Panel of XCRF-860, each of which can be connected to an antenna or a load of 50 Ω (optional). Four pieces of RF cable for RP-SMA to RP-N type connectors are included in the standard delivery. The antenna port of the XCRF-860 reader may be susceptible to damage if power on the reader**

without an antenna connection or without a dummy load mounted to the port.

5.1.3 Top panel

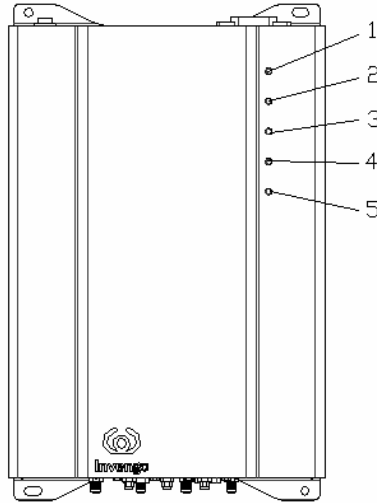

Fig. 5-5 The Top Panel of XCRF-860

- 1—Power indicator lamp;
- 2—Lamp of antenna port 1;
- 3—Lamp of antenna port 2;
- 4—Lamp of antenna port 3;
- 5—Lamp of antenna port 4.

(Note: green indicates the port is selected, flickering of green and red lamps indicate that the tags are read via the port.)

5.1.4 Bottom panel

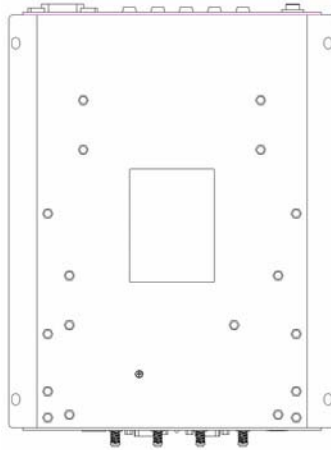

Fig. 5-6 The Bottom Panel of the XCRF-860 Reader

Four ports on bottom panel are available for mounting the XCRF-860 on a wall.

A nameplate is attached to the bottom panel.

5.2 The Internal Structure and the Modules

5.2.1 Power Unit

- ✎ Transform AC input voltage into DC output voltage, to provide DC power to the XCRF-860 reader.



No internal UPS power supply is provided to the XCRF-860.

5.2.2 Data Interface Unit

- ✎ Connect the RS-232, network port and power port of

the XCRF-860 reader to the back panel of the cabinet via standard connectors.

5.2.3 Cabinet

- ✎ The cabinet uses aluminum alloy sections with exterior protective layer of oxide metal.

5.3 Auxiliaries

A complete RFID data collecting system is comprised of an RFID reader, tags, antennas, PC and reader interface software. The specific requirements of the auxiliaries are as follows.

5.3.1 PC

The minimum PC requirements:

- ✎ 9-pin RS-232 serial port;
- ✎ Windows 98/2000/XP with stable performance;

5.3.2 RF Cable

The requirements of RF cables:

- ✎ Maximum length: 10m;
- ✎ Impedance: 50Ω.



A piece of RF cable of excessive length will result in attenuation of transmitted signals, and the attenuation of received echo signals will also be augmented, both of which will therefore reduce the distance of read and write.

5.3.3 Reader Interface Software

- ✎ API dynamic link library for XCRF-860 reader;
- ✎ Demo Software for the XCRF-860 reader



For more information, please refer to *the Technical Reference Handbook to XCRF-860 Reader* and *the Demo software user's manual of XCRF-860 reader*.

5.3.4 Antenna

User of the XCRF-860 reader is recommended to use UHF antennas of linear polarized XCAF-11L or circular polarized XCAF-12L from Invengo Information Technology Co., Ltd.

In addition, various options are also available. The antennas you use can be compatible to the XCRF-860 reader if they conform to the following specifications:

- ✎ Impedance: 50Ω.
- ✎ Operating Frequency: 902 to 928MHz
- ✎ Antenna Gain:6dBi



The XCRF-860 reader must be sold together with UHF Antennas of XCAF-11L or XCAF-12L, and this antennas can not be sold by single.

5.3.5 Communication Cable

There are 3 modes of communication between the reader and a PC available: the network connection and the serial

connection and USB connection. The requirements on the network cable and the serial cable are as follows:

- ✎ Maximum length of network cable: 10m. The cable for connection to a switch and the cable for direct connection to a PC are of different requirements. A through line is required for the former; while a cross wire is required for the latter.
- ✎ Serial cable: a piece of cross line with a maximum length of 5m
- ✎ USB cable: USB 2.0 cable with 2 A type male connectors

6 Operation Instructions

6.1 Application environment Demo Software

- ✎ Software environment
Windows9x, Windows2000, Windows XP
- ✎ Hardware requirements
P4/1.7GHz plus CPU; 128M plus memory .

6.2 Initiating of Demo Software

Copy the file named “set up” to a directory on a local PC.

1. Installing Demo Software

Click the file named “setup”

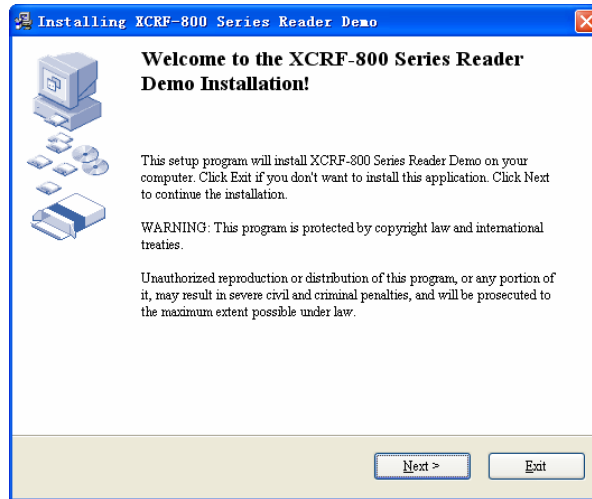

Fig. 6.1 Installation Step 1

Click "Next".

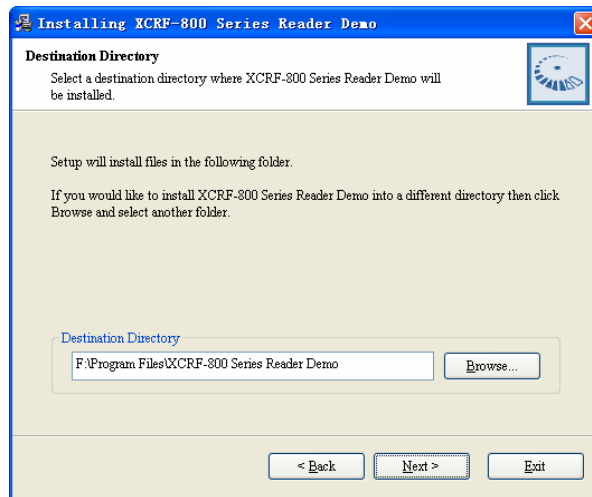

Fig. 6.2 Installation Step 2

Select the installation directory, and click "Next".

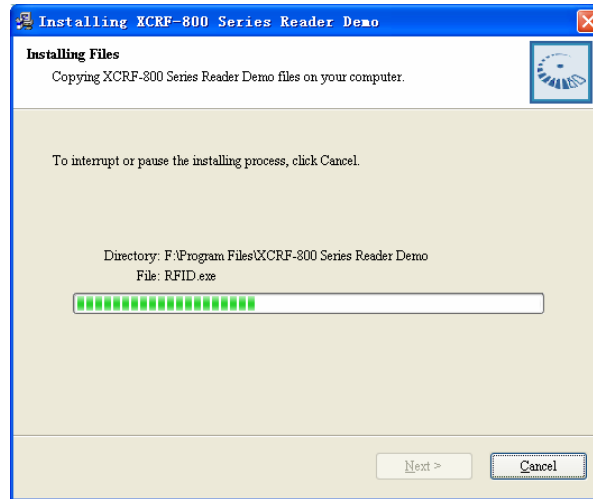

Fig. 6.3 Installation Step 3

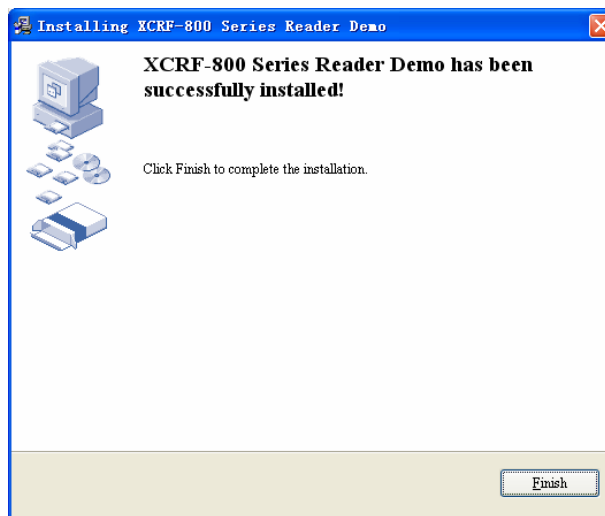

Fig. 6.4 Installation Step 4

Click “Finish” to complete the installation.

2. Running the Demo Software

Click the file named XCRF-800 Series Reader Demo.exe that both on the installation directory and the desktop, and run it.

6.3 Complementary tool for XCRF-860 Demo Software Source

The XCRF-860 reader CD-ROM include Installation file named “setup”, USB driver program, dynamic link library of API interface functions (e.g. XCRFAPI.dll, XCRFAPI.Lib, XCRFAPI.h), etc.

6.4 Reader Configuration

Run the Demo Software, as illustrated in Fig. 6.5:

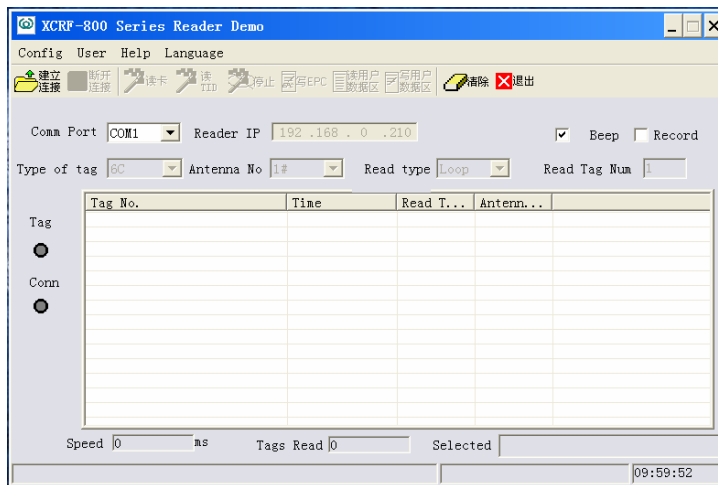
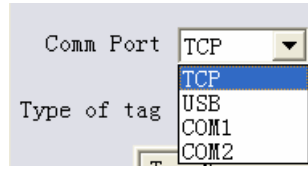

Fig. 6.5 Main Interface of the Software

1. Port Configuration

Select “TCP”, “USB”, or “Com1” etc. under “communication port selection”, as illustrated in Fig. 6.6.



6.6. Port Configuration

If “Serial Communication” is selected, the Serial Port should be connected to the serial port on the PC via serial cable. Select the serial number listed on the pop-down manual.

If select “TCP”, input the XCRF-860 reader’s IP.

If the Reader's IP is not configured yet, configure the IP address by completing the following steps.

- 1) Connect the Communication Port

Connect the serial port on the XCRF-860 reader to the port on the Host. Select “Serial Communication Mode” as “Communication Port” as illustrated in Fig. 6.7:



Fig. 6.7 The Communication Port Selection

- 2) IP Address Configuration

Select “config” —> “Config Reader parameter”, configure the IP address on the Pop-up manual as illustrated in Fig. 6.8.

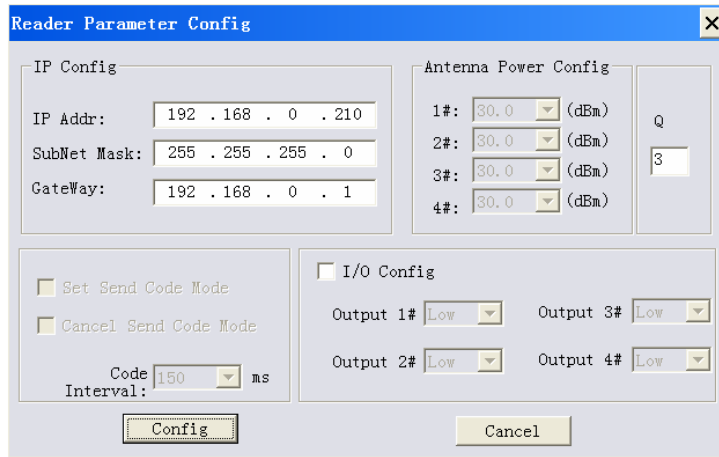



Fig. 6.8 IP Address Configuration

Click OK to close the dialog box.

 **Complete the IP address configuration as illustrated in “1. Port Configuration”**

 **If the network connection is successful, the domain name of the set IP address must be identical with that of the host (the reader's default IP address is: 192.168.0.210).**

3) Restart the equipment

Turn off the reader. And then turn on the power supply to restart the reader.

4) Select the Communication Mode

Select TCP as Communication Mode.

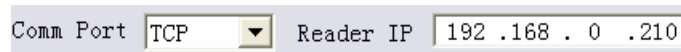

Fig. 6.9 Select TCP as Communication Port

If select USB communication mode, please assure that the USB driver is installed on the PC and the PC is ready for USB operation. The installation of USB drive is illustrated as follows:

Connect the Reader and the PC with A USB cable. Power on the Reader and “Found New Hardware” message will pop up on the bottom right of the PC screen.

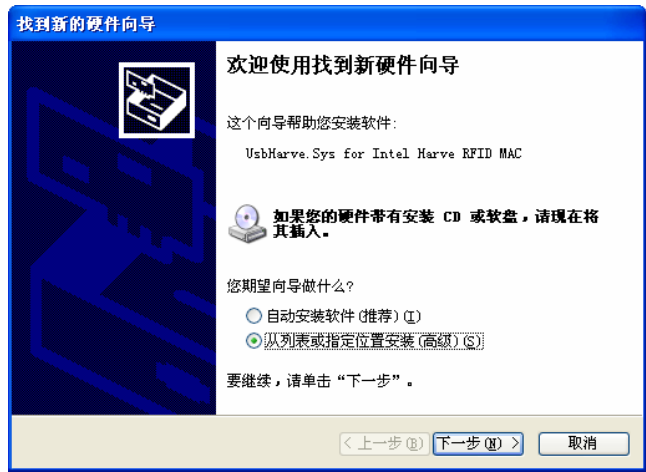

Fig. 6.10 USB Driver Installation Step 1

Click “Next”.

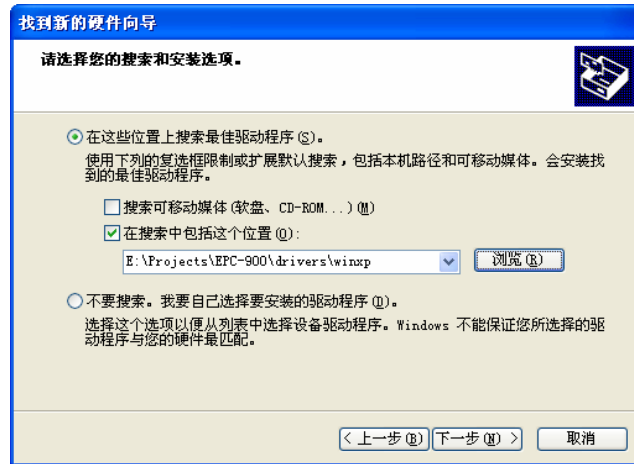

Fig. 6.11 USB Driver Installation Step 2

In Explorer, locate the driver folder.

Click “Next”.



Fig. 6.12 USB Driver Installation Step 3

Click “Next”.



Fig. 6.13 USB Driver Installation Step 4

Click “finish”. “Found New Hardware ready for use” message will pop up on the bottom right of the PC screen. The communication between the USB port and reader is established.

6.5 Operation Instructions on Demo Software

Select the communication port, click , and a message of “connection established” pops up on the screen. (Meanwhile, the connection status lamb will turn green, and the type of reader and the version information of baseband software display on the title bar.)

Select “6C” as “the type of tags” in the choice box, to perform the operations on ISO18000-6C compliant tags.

Select the number of antenna in use; “1” indicates that antenna port 1 is connected to an antenna; “1# - 2#” indicates

that the reader operates alternately on the specified antennas of “1# - 2#”. “1# - 3#” indicates that the reader operates alternately on the specified antennas of “1# - 2# - 3#”. “1# - 4#” indicates that the reader operates alternately on the specified antennas of “1# - 2# - 3# - 4#”.

1. Reader interrogates RFID tags

Configure the “estimated number of tags to read” approximate to “number of tags which are read”; select “circulatory” (circulatory read of tags) or “one time” (read tags for one time) in pull-down manual of “read mode”; then click , and “tag number”, “read time”, “read times” and “antenna number” display on main interface.

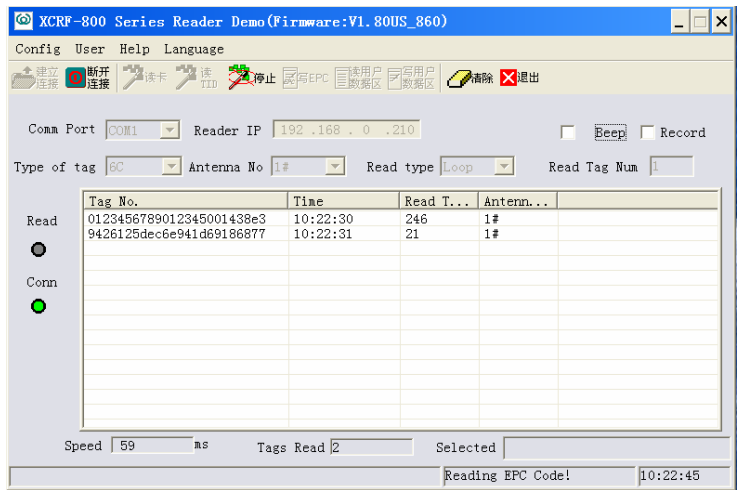



Fig. 6.14 Tag Read

2. Operating Frequency Configuration

The reader's operating frequency is 902.75MHz to 927.25MHz. The frequency gaping is 500KHz, and the reader has 50 operating frequency points. The default operating frequency configuration is "frequency hopping": "Default A"; the frequency points range from 902.75MHz to 910.25MHz, with 16 frequency points. RFID Demo software also provides a "Default B" for frequency-hopping, of which the frequency points are , with 16 frequency points.

How to configure the frequency point: click "configuration" on the main interface → select "Frequency Hoping Manager" → select "Frequency Hoping" on the pull-down menu named "Frequency Hoping Selection" → select the frequency on the left list box by clicking  or  → the frequencies selected will display on right list box → click "confirm" to complete the reader's operating frequency configuration.

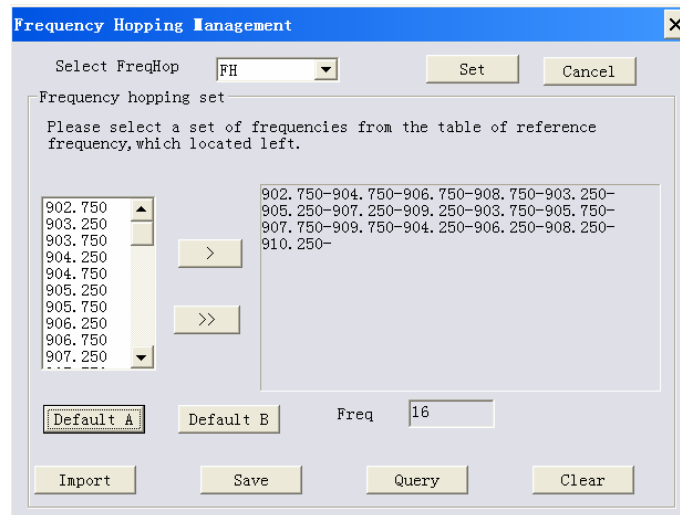

Fig. 6.15 Reader's Operating Frequency Configuration

3. Configuration of Multiple Readers Operation

As illustrated in Fig. 6.16, if two or more readers operate in proximity, the instructions below must be followed during installation and commissioning, so as to eliminating interference to each other.

1. The minimum distance of the centers of the antennas of two adjacent readers must be 3m;
2. The operating frequencies of two adjacent readers must be respectively configured as "Default A" and "Default B".

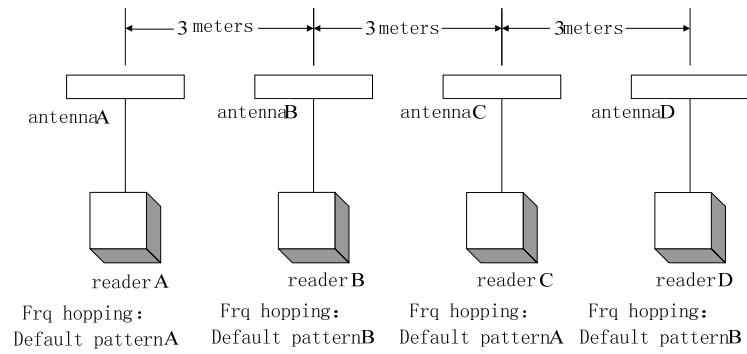

Fig. 6.16 Layout of Multiple Readers Operation

6.6 Common Faults and Troubleshooting

Power supply system failure

- ☆ Check if the AC power supply is OK, and if the AC power voltage is of 100V to 240V;
 - if other indicator lamps are on, a failure may occur to the internal MCU; users must contact Invengo for technical support;

Network Port Connection Failure:

The default IP address is 192.168.0.210. If the PC IP address (e.g. "192.168.0.XXX") and reader's IP address (e.g. "192.168.0.XXX") are of one segment network, the connection between the reader and PC can be established. The reader IP can be reconfigured by using Demo software on a computer with RS-232 connectivity.

Network Port Connection Failure:

☆ The baud rate of reader is 115200bps; Check if the value of XC_BaudRate in the file:sysit.cfg under the installation directory is 115200.

☆ Check if COM port matches the connection of XCRF-860 reader and PC.

☆ If the serial port cable is correctly connected, as disconnection or loose connection may result in the failure to receive the PC's instructions to XCRF-860 reader.

Network Port Connection Failure:

☆ Check if the USB driver is installed in the PC; if not, install the USB driver as instructed in 6.4.

☆ Check if the USB cable is correctly connected, as disconnection or loose connection may result in the reader's failure to receive the PC's instructions to XCRF-860 reader.

Card Read Failure

☆ Check if the serial port cable, USB cable or network cable is connected, as disconnection or loose connection may result in the reader's failure to receive the PC's instructions to XCRF-860 reader.

☆ Check if SMA connector of antennas are screwed up, and if the tags are damaged.

☆ Check if the selected "antenna number" is that of the antenna used.

☆ Check if the "estimated number of tags to read" is approximate to that of the tags within Antenna's coverage range.

For more technical support, please contact Invengo.

7 After-sale Service and Contact Information

7.1 After-sale Service

Please contact our customer service center if the technical support is required.

Please provide the following information, when you contact our customer service center:

7.1.1 The Reader

- ✎ The model of the reader;
- ✎ The reader's S/N (on the bottom of the reader);
- ✎ The modification information of the reader or the tags;
- ✎ The reader's installation location;
- ✎ The application software for the XCRF-860 reader.

7.1.2 PC

- ✎ Brand and model of the PC;
- ✎ CPU information and RAM available;
- ✎ The COM port used;
- ✎ The information of the PC's OS.

7.2 Contact Information

Invengo Information Technology Co., Ltd.

Add: 3/F, No. T2-B, High-Tech Industrial Park South, Shenzhen, China

Post code: 518057

Tel: 0755-26711686; 26711633

Fax: 0755-26711693

URL: <http://www.invengo.cn>

E-mail: sales@invengo.cn

7.3 Other Issues

A Return Merchandise Authorization (RMA) will be sent to you if the equipment/s is/are required to return back to Invengo Information Technology Co., Ltd. Please mark the number of RMA on the surface of the package and within the package, so as to assure that the returned product will be repaired in time.

Please follow the following steps to return the reader for repair:

- ☞ Carefully pack the reader and its accessories and put them into the original antistatic foam package; Please find a package with equal protection if the original package is unavailable;
- ☞ Cover the items in the package with filling materials;
- ☞ A note marking the RMA number attached within the package;
- ☞ Mark the RMA number and “Fragile” on the surface of the package.

***For more information, contact
sales toll free at
800-830-7036***