

# **Mercury User Manual**

Version 1.2

December 12, 2005

**Table of Contents**

<b>Chapter 1. Knowing Your Device .....</b>	<b>7</b>
1.1 Introduction.....	8
1.1.1 Views of the device.....	8
1.1.2 Hardware keyboard.....	9
1.1.3 Stylus.....	10
1.1.4 Notification LED .....	11
1.2 Accessories.....	11
1.3 Install SIM card and battery.....	12
1.4 Charging the Battery .....	14
1.5 Mini-SD cards .....	14
<b>Chapter 2. Basic Operations .....</b>	<b>17</b>
2.1 Getting Started .....	18
2.1.1 Power on/off the device .....	18
2.1.2 Device calibration .....	18
2.1.3 Lock/Unlock the device .....	18
2.2 Input methods.....	19
2.2.1 On-screen keyboard .....	20
2.2.2 Letter Recognizer.....	20
2.2.3 Block Recognizer.....	21
2.2.4 Transcriber .....	21
2.3 Today Screen components .....	22
2.3.1 Today screen .....	22
2.3.2 What do those status icons indicate?.....	23
2.4 Start Menu.....	25
2.5 Settings.....	27
2.5.1 Personal.....	27
2.5.2 System.....	27
2.5.3 Connections.....	28
2.6 Calendar .....	28
2.6.1 Schedule an appointment .....	29
2.6.2 Delete an appointment .....	29
2.6.3 Change the reminder time .....	29
2.6.4 Change views in Calendar .....	30
2.6.5 Change the display of the work week .....	31

2.7 Notes .....	31
2.7.1 Set the default input mode .....	31
2.7.2 Create a note .....	31
2.7.3 Delete a note .....	32
2.7.4 Create a voice recording .....	32
2.8 Tasks.....	32
2.8.2 Delete a task .....	33
2.8.3 Change task priority .....	33
2.8.4 Sort/Filter your tasks .....	33
2.8.5 Set Tasks options.....	34
<b>Charter 3. Phone Features .....</b>	<b>36</b>
3.1 Making a call.....	37
3.1.1 Make a call by entering a phone number .....	37
3.1.2 Make a call from Call History .....	37
3.1.3 Make a call from Contacts .....	37
3.1.4 Use a speed dial .....	37
3.1.5 Create a speed dial .....	38
3.2 Receiving/Rejecting a call .....	38
3.2.1 Receive a call .....	38
3.2.2 End a call.....	38
3.2.3 Block incoming or outgoing calls .....	38
3.3 Call options .....	39
3.3.1 Conference Call .....	39
3.3.2 Call waiting.....	39
3.3.3 Turn Speaker On/Off.....	39
3.3.4 Mute/Unmute the microphone .....	39
3.4 Flight mode .....	40
<b>Chapter 4. Synchronizing Information .....</b>	<b>43</b>
4.1 Install and set up ActiveSync .....	44
4.2 Connect the device .....	47
4.3 Start and stop synchronization .....	47
4.4 Change ActiveSync settings.....	47
4.5 Change settings for an information type .....	48
4.6 Set up an Exchange Server connection .....	48
4.7 Connect to a PC using infrared .....	49
4.8 Connect to a PC using Bluetooth .....	49

<b>Chapter 5. Bluetooth/Infrared Connections.....</b>	<b>51</b>
5.1 Overview of Bluetooth.....	52
5.2 Sending/Receiving beamed information.....	52
5.2.1 Turn Bluetooth on and off.....	52
5.2.2 Make your device discoverable .....	53
5.2.3 Create a Bluetooth partnership.....	53
5.2.4 Receive beamed information (Bluetooth & Infrared).....	55
5.2.5 Beam an item (Bluetooth & Infrared).....	57
<b>Chapter 6. Transferring files to your device.....</b>	<b>59</b>
6.1 Using ActiveSync to transfer files .....	60
6.2 Transferring files from memory cards .....	61
6.3 Using infrared to transfer a file.....	62
6.4 Using Bluetooth to transfer a file.....	63
<b>Chapter 7. Setting up Internet Connection .....</b>	<b>67</b>
7.1 Create a GPRS connection.....	68
7.2 Create a proxy connection .....	69
7.3 Delete a connection.....	70
<b>Chapter 8. Internet Explorer .....</b>	<b>73</b>
8.1 Browsing the Internet.....	74
8.2 Add a Web page to the Favorite list .....	74
8.3 Delete a favorite.....	75
8.4 Change the size of text on Web pages.....	75
8.5 Show or hide pictures on Web pages .....	75
8.6 Change Web page display options .....	75
8.7 Clear history, cookies, or temporary files .....	75
8.8 View a page in full screen mode .....	76
<b>Chapter 9. Messaging &amp; Contact .....</b>	<b>78</b>
9.1 Text messages .....	79
9.1.1 Create a text message.....	79
9.1.2 Using preset text messages .....	79
9.1.3 Read a text message.....	80
9.1.4 Message options.....	80
9.2 Multimedia Messaging Service.....	80
9.2.1 Set up a MMS account.....	80
9.2.2 Compose a MMS message.....	80
9.2.3 Read a MMS message.....	81

9.2.4 Preview a MMS message.....	81
9.2.5 Configure MMS settings.....	81
9.3 Outlook E-mail.....	81
9.3.1 Set up an Internet e-mail account manually.....	81
9.3.2 Compose an e-mail message.....	83
9.3.3 Read an Outlook E-mail message.....	84
6.3.4 Message options.....	84
9.4 Change Messaging account options.....	84
9.5 Contacts.....	84
9.5.1 Create a new contact.....	84
9.5.2 View and edit contact information.....	84
9.5.3 Add a picture to a contact.....	85
9.5.4 Assign a ring tone to a contact.....	85
9.5.5 Find a contact.....	85
9.5.6 Send an e-mail to a contact.....	85
9.5.7 Send a text message to a contact.....	86
9.5.8 Create a SIM contact.....	86
<b>Chapter 10. Photo Contacts .....</b>	<b>88</b>
10.1 Transfer photographs to your device.....	89
10.2 Add a new photo contact.....	89
10.3 Add a photo to a SIM contact.....	90
<b>Chapter 11. Other Applications .....</b>	<b>95</b>
11.1 Word Mobile.....	96
11.1.1 Create a document.....	96
11.1.2 Word Mobile formatting toolbar.....	96
11.2 Excel Mobile.....	97
11.2.1 Create a new spreadsheet.....	97
11.2.2 Excel Mobile formatting toolbar.....	98
11.3 PowerPoint Mobile.....	98
11.3.1 Start a PowerPoint presentation.....	99
11.3.2 Stop a PowerPoint presentation.....	99
11.3.3 Navigate between slides.....	99
11.4 MSN Messenger.....	99
11.4.1 Sign in/out MSN Messenger.....	99
11.4.2 Add/Delete a MSN Messenger contact.....	100
11.4.3 Send an instant message.....	100

11.4.4 Change MSN Messenger display name .....	100
11.4.5 Block/Unblock a contact.....	101
11.4.6 Change MSN Messenger settings .....	101

<b>Inventec</b>	<b>Manual</b>	版 本 : 01
	Mercury	日 期 : 95/12/12

# Chapter 1. Knowing Your Device

### 1.1 Introduction

#### 1.1.1 Views of the device

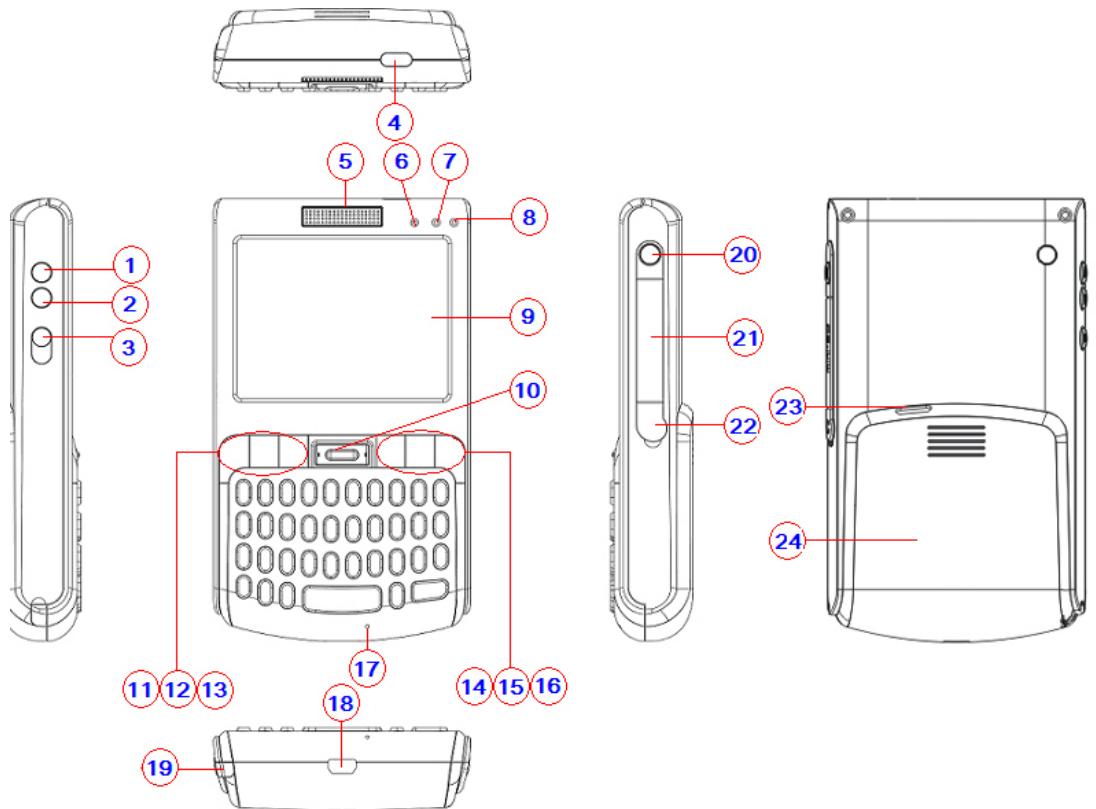

1	Volume up	Press the Volume up button to turn up the receiver volume
2	Volume down	Press the Volume down button to turn down the receiver volume
3	Voice Record	Press record to record a voice note
4	IrDA	Transfer information with other device through infrared
5	Receiver	Listen to a phone call here
6	Message LED	Please refer to Notification LED section of this chapter
7	Bluetooth LED	Please refer to Notification LED section of this chapter
8	GSM/Battery LED	Please refer to the Notification LED





		section of this chapter
9	Display	2.8-inch TFT touch screen
10	4-way navigation and action input key	Press this button up, down, left, or right to move through menus.
11	Talk key	Press this key to dial or answer a call
12	Start key	Pull down the Start menu
13	Soft key 1	
14	Soft key 2	
15	OK key	Press OK key to make a selection
16	End key	End a call or close Phone application
17	Microphone	Speak into the microphone when talking on the phone or recording a voice note
18	USB slot	Mini USB slot for PC sync and battery charging
19	Stylus	Write, draw, or make selection with the stylus
20	Power key	Power on or off the device
21	Mini SD card slot	Insert a mini SD card to expand device memory
22	Ear phone connector	Connect a 2.5 mm ear phone
23	Speaker	Listen to audio media or listen to a phone call hands-free
24	Battery pack	

### 1.1.2 Hardware keyboard

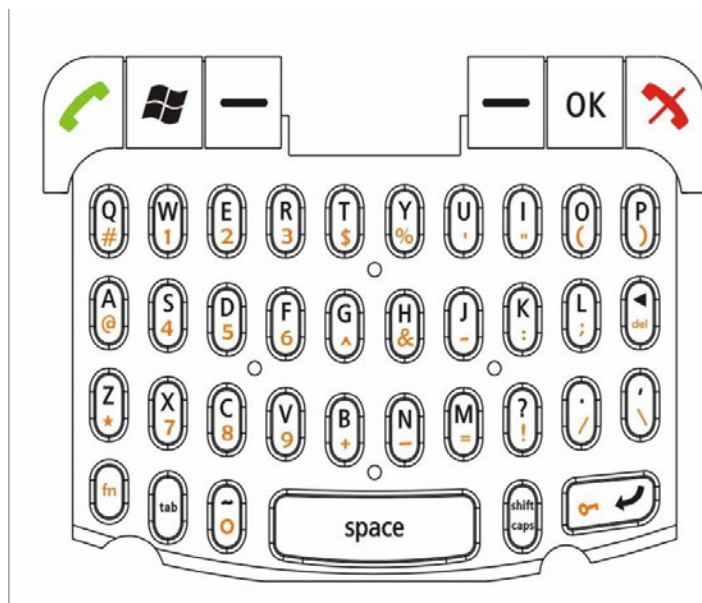
Other than the on-screen keyboard, this device is equipped with a hardware keyboard.



To enter capital letters and/or numbers using the hardware keyboard:

	<p>Press this key and the <b>Fn</b> icon appears. You can then enter numbers and symbols.</p>
	<p>Press this key once the first letter you enter is capitalized (for example: Abc.)</p> <p>Hold this key until the <b>caps</b> icon appears. All letters you enter will be capitalized (for example: ABC.) Press this key again to enter lower case letters.</p>

### 1.1.3 Stylus

- Use the stylus to tap a selection, to drag-and-drop an item, to write, or to draw on the TFT touch screen.
- Tap and hold the stylus on the screen,  icon is displayed and then a shortcut menu is displayed.



#### 1.1.4 Notification LED

The device has 3 notification LEDs, starting from left to right: Message LED, Bluetooth LED, and GSM/Battery LED.

Message LED lets you know that you have unread SMS/MMS message(s) or unanswered call(s):

Color	Missing Call SMS/MMS in GSM on	Clear Missing Call/SMS/MMS Notification
Orange	Blink	Off

Bluetooth LED (blue) tells you about the device's Bluetooth status:

Color	Bluetooth on	Bluetooth off
Blue	Blink	Off

GSM/Battery LED (green/red) tells you about the device's GSM status and battery status:

Color	GSM on	GSM off	GSM on (battery full)	GSM off (battery full)	Charging
Green	Blink	Off	Blink	ON	off
Red	Off	Off	Off	off	ON

#### 1.2 Accessories



1	AC Adapter	Recharge the device battery
2	Stereo headset	Listen to a phone conversation hands-free
3	USB Cable	Connect the device to a PC

### 1.3 Install SIM card and battery

- Install SIM card:

If you want to use phone features, you must install a GSM SIM card.

1. Push the back cover down and slide it open.
2. Lift up the SIM card slot's metal plate.
3. Place the SIM card in the SIM card slot with the gold contacts facing down.  
The SIM card's cut-off corner should match the cut-off corner in the SIM card slot.
4. Snap the metal plate to lock the SIM card in place.

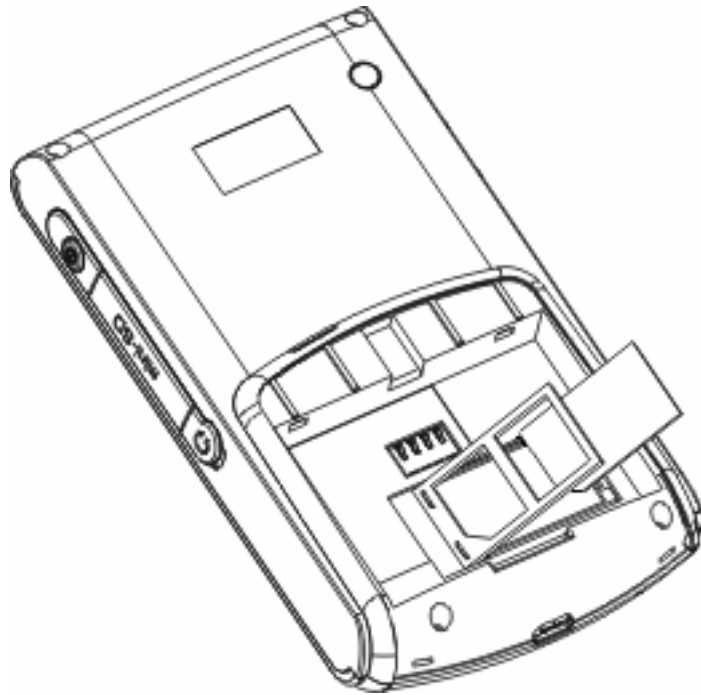

- Install battery:
  1. Place the battery in proper place by pressing it's protrusions on the side of the battery against the sockets inside the battery slot.
  2. Press the battery down into the battery slot and close the back cover.

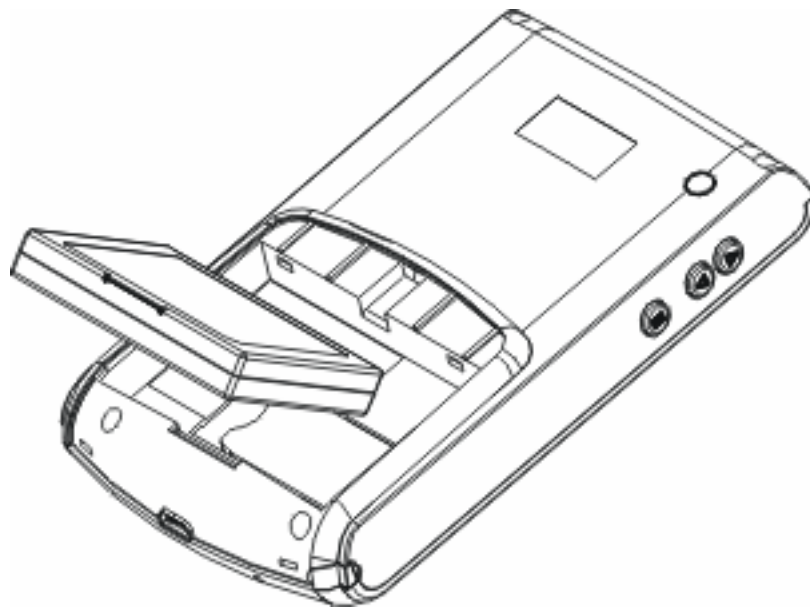

**Warning**

The device contains a rechargeable Li-ion polymer battery completely discharged and should be charged for at least 8 hours before first use. Use only manufacturer-specified original batteries. Damages caused by using batteries not specified by manufacturer are not covered under warranty.

#### 1.4 Charging the Battery

1. To charge the battery, place the battery into the battery slot correctly. See previous section for how to install the battery.
2. Do one of the following:
  - Connect the device with the AC adapter and plug the AC adapter into a power outlet.
  - Connect the device to a PC with the USB cable.

**Note**

To charge the device with the USB cable, you must connect the device to a functioning USB port on a PC that is powered on.

#### 1.5 Mini-SD cards

Mini-SD is one of the most popular formats for mobile devices. Your device contains a mini-SD card slot in which you can expand the device's memory up to 4GB.

Mini-SD provides functions such as built-in security for copyrighted content along with great performance for storing music, video, and photographs.

##### Inserting a mini-SD card into the device

1. Lift the mini-SD card slot cover.
2. Insert the mini SD card with the logo side up and push into place until it clicks down and is held in place.
3. Replace the mini-SD card slot cover.

**Caution**

Mini-SD cards can only be inserted in one direction. Inserting the card in the wrong direction by force can cause damage to the card and the card slot.

## Removing a mini SD card from the device

1. Gently press the mini-SD card inward and the card will eject itself.
2. Take out the mini-SD card from the card slot by hand.

<b>Inventec</b>	Manual	版 本 : 01
	Mercury	日 期 : 95/12/12



<b>Inventec</b>	<b>Manual</b>	版 本 : 01
	Mercury	日 期 : 95/12/12

## **Chapter 2. Basic Operations**

## 2.1 Getting Started

### 2.1.1 Power on/off the device

Press the POWER button to turn on the device. The POWER button is located on the right side of the device. When you power on the device for the first time, you are asked to calibrate the device. Please refer to the “Device calibration” section in this chapter for calibration steps. Press the POWER button again to switch the device to sleep mode. You can still receive phone calls and messages when the device is operating on sleep mode.

### 2.1.2 Device calibration

Calibrating the device ensures the tapped item is activated. To calibrate your device, tap the center of the cross with the stylus as the cross moves around the screen. If you would like to re-calibrate the device, follow the steps below:

1. Tap  > **Settings** > **System** tab > **Screen**
2. Tap the **Align Screen** button and follow the on-screen instructions.



Tap the target firmly and accurately at each location on the screen. The target will continue to move until the screen is aligned. 

### 2.1.3 Lock/Unlock the device

Locking the device turns off keyboard functionality. This is a helpful feature if, for example, the device is turned on and in your pocket, and you want to prevent accidental key presses.

To lock the device, press the fn key followed by the Enter key. Once the device is locked, the left soft key label changes to **Unlock**. You can also tap on the  icon to lock the device.

**Note**

You can still receive calls and make emergency calls when the keypad is locked.

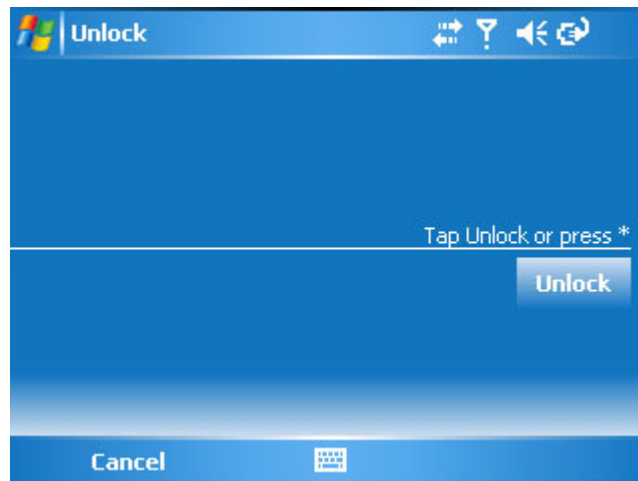

Unlocking the device turns on the keyboard functionality. To unlock the device, tap **Unlock** and press the \* key or tap the **Unlock** button on the screen.



## 2.2 Input methods

The device contains 4 different input methods: On-screen Keyboard, Letter Recognizer, Block Recognizer, and Transcriber.

Icon	Input Method
	On-screen Keyboard

	Letter/Block Recognizer
	Transcriber

### 2.2.1 On-screen keyboard

- Tap  to launch the on-screen keyboard. If On-screen Keyboard is not the selected input method, tap the input method selector arrow (the upward arrow next to the input method icon) and select **Keyboard**.
- To enter text, tap the keys on the on-screen keyboard.



- Tap the CAP key on the on-screen keyboard to enter capital letters and/or symbols.



### 2.2.2 Letter Recognizer

Letter Recognizer recognizes one letter, number, or symbol at a time.

- To launch Letter Recognizer, tap the input method selector arrow (the upward arrow next to the input method icon) and select **Letter Recognizer**.
- Write uppercase letters in the left recognition area (the ABC box.)
- Write lowercase letters in the middle recognition area (the abc box.)
- Write numbers and symbols in the right recognition area (the 123 box.)

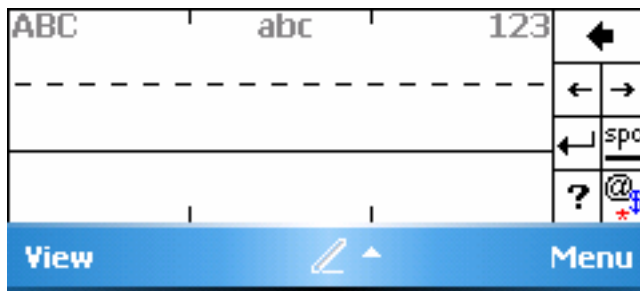

### Tip

Tap ? in Letter or Block Recognizer to see a demo on how to write recognizable characters.

### 2.2.3 Block Recognizer

Block Recognizer recognizes letters written in one stroke.

- To launch Block Recognizer, tap the input method selector arrow (the upward arrow next to the input method icon) and select **Block Recognizer**.
- Write lowercase letters in the text recognition area (the abc box.)
- Write numbers and symbols in the numeric recognition area (the 123 box.)
- To input symbols, tap any recognition area, text or numeric, once and write symbols.

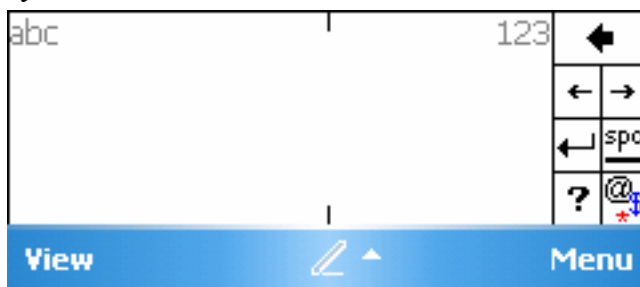

### Tip

Tap ? in Letter or Block Recognizer to see a demo on how to write recognizable characters.

### 2.2.4 Transcriber

Transcriber recognizes handwritings in cursive and/or print. It uses the full screen as its recognition area. It interprets the movement of the stylus on the screen as you

write.

- To launch Transcriber, tap the input method selector arrow (the upward arrow next to the input method icon) and select **Transcriber**.
- Write anywhere on the screen.



The Transcriber comes with a detailed help. Tap ? if you need further assistance.

## 2.3 Today Screen components

### 2.3.1 Today screen

The Today Screen is usually the first screen that appears when you turn on the device for the first time each day. It displays a summary of information for the day, shows you the system status and contains a list of shortcuts to programs. The Today screen looks like this:



1	Mobile/Wireless status
2	Unread messages including text messages, MMS messages, and e-mails



















3	Active tasks
4	Device lock status
5	Upcoming appointments
6	Sign in to Pocket MSN































**Note**

You can also access the Today screen by selecting **Today** from the Start menu.







2.3.2 What do those status icons indicate?

Status indicators appear at the top of the screen and on the Home screen. The following table lists common status indicators and their meanings.

Indicator	Meaning
	New e-mail or text message (SMS)
	New voice mail
	New instant message
	Voice call
	Voice call in progress
	Data call in progress
	Calls are forwarded
	Call on hold
	Missed call
1 / 2	Line 1/Line 2
	Battery level
	Low battery
	Battery charging
	No battery
	Signal strength
	No signal
	Roaming
	Sync error
	Radio off

	Ringer off
	1XRTT connection available
	No voice mail
	Voice mail Line 1
	Voice mail Line 2
	Voice mail Lines 1 and 2
	Call Forwarding Line 1
	Call Forwarding Line 2
	Call Forwarding Lines 1 and 2
	Wi-Fi connected
	Pending alarm
<b>Indicator</b>	<b>Meaning</b>
	New e-mail
	New voice mail
	New instant message
	Voice call
	Voice call in progress
	Data call in progress
	Calls are forwarded
	Call on hold
	Missed call
	Battery level
	Low battery
	Battery charging
	No battery
	Signal strength
	No signal
	GPRS available
	GPRS in use
	Roaming
	Sync error



	Radio off
	Ringer off
	Missing SIM card
	Faulty SIM
	No voice mail
	Wi-Fi connected
	Pending alarm

### 2.4 Start Menu



















The Start menu is divided into 3 groups as described in the following:

1	Recently accessed applications
2	Commonly used items
3	List of all programs, device settings, and system help











#### 2.4.1 List of all programs

	<b>Games</b>	Windows Mobile comes with 2 games: Bubble Breaker and Solitaire.
---	--------------	--





	<b>ActiveSync</b>	See “Chapter 4. Synchronizing Information” for details.
	<b>Calculator</b>	
	<b>Download Agent</b>	Download Windows Mobile updates.
	<b>Excel Mobile</b>	See “11.3 Excel Mobile” for details.
	<b>File Explorer</b>	Manage the files on the device with File Explorer.
	<b>Modem Link</b>	Use the device as a modem.
	<b>Notes</b>	See “2.7 Notes” for details
	<b>Photo Contact</b>	See “Chapter 10 Photo Contacts” for details.
	<b>Pictures &amp; Video</b>	Manage pictures and video clips.
	<b>Pocket MSN</b>	MSN services for mobile devices.
	<b>PowerPoint Mobile</b>	See “11.3 PowerPoint Mobile” for details.
	<b>Search</b>	Search the data stored in your device.
	<b>SIM Contacts</b>	Manage your SIM phonebook.
	<b>SIM Toolkit</b>	A software toolkit comes with the SIM card.
	<b>Tasks</b>	See “2.8 Tasks” for details
	<b>Terminal Services Client</b>	
	<b>Word Mobile</b>	See “11.1 Word Mobile” for details.









## 2.5 Settings

### 2.5.1 Personal





	<b>Buttons</b>	Configure the device's buttons.
	<b>Input</b>	Input method configurations.
	<b>Lock</b>	Set a password to unlock the device.
	<b>Menus</b>	Configure the Start menu.
	<b>MSN Options</b>	Configure MSN services.
	<b>Owner Information</b>	Enter information about the owner of the device.
	<b>Phone</b>	Configure the Phone features. See "Chapter 3 Phone Features" for details.
	<b>Sounds &amp; Notifications</b>	Configure program and event sounds.
	<b>Today</b>	Configure the Today screen items and theme.
	<b>Voice Command</b>	Enable or disable voice in applications.

### 2.5.2 System

	<b>About</b>	Windows Mobile information and device name.
	<b>Backlight</b>	Configure the display backlight.
	<b>Certificates</b>	Manage personal and root certificates.
	<b>Clock &amp; Alarms</b>	Set time and alarms.
	<b>Contrast</b>	Adjust the display contrast.

	<b>Error Reporting</b>	Enable or disable Microsoft product error reporting.
	<b>GPS</b>	GPS configuration.
	<b>Memory</b>	Memory and process management.
	<b>Mercury Version</b>	Display the device software version.
	<b>Power</b>	Power management settings.
	<b>Regional Settings</b>	Configure the device's locale.
	<b>Remove Programs</b>	Remove an install application.
	<b>Screen</b>	Screen alignment. See "2.1.2 Device Calibration" for details.

### 2.5.3 Connections

	<b>Beam</b>	Turn on/off the beam feature.
	<b>Bluetooth</b>	Configure Bluetooth settings. See "Chapter 5 Bluetooth/Infrared Connections" for detail.
	<b>Connections</b>	Configure the device's connections.
	<b>Network Cards</b>	Configure Network adapter.
	<b>Wireless Manager</b>	Turn on/off wireless and phone features with the Wireless Manager.

### 2.6 Calendar

Use Calendar to schedule appointments, including meetings and other events. Your appointments for the day can be displayed on the Today screen. If you use Outlook on your PC, you can synchronize appointments between your device and PC. You can also set Calendar to remind you of appointments with a sound or flashing light, for example.

You can look at your appointments in several different views (Day, Week, Month, and Agenda). To see detailed appointment information in any view, tap the appointment. For information about changing the Calendar view, see Change views in Calendar.

### 2.6.1 Schedule an appointment

1. Tap  > **Calendar**.
2. Tap **Menu** > **New Appointment**.
3. Enter information about the appointment.
4. To schedule an all-day event, under **All Day**, select **Yes**.
5. Tap **Ok**.

#### **Note**

All-day events do not occupy blocks of time in Calendar; instead, they appear in banners at the top of the calendar.

### 2.6.2 Delete an appointment

1. Tap  > **Calendar**.
2. In Agenda view, select the appointment to delete.
3. Tap **Menu** > **Delete Appointment**.
4. If the appointment is recurring, tap **Yes** to delete the series, or tap **No** to delete only the current occurrence.

#### **Notes**

When you delete an appointment in Calendar on your phone, it is also deleted on your PC the next time you synchronize. If the appointment has not been synchronized with a PC, it will be deleted only from the phone.

Calendar items can be deleted only from Agenda view or from an open calendar appointment. To delete from other views, open the appointment, and Tap **Menu** > **Delete**.

### 2.6.3 Change the reminder time





By default, the reminder time is set 15 minutes prior to an appointment.

1. Tap  > **Calendar**.
2. Tap **Menu** > **Options**.
3. Tap **Appointment** tab and change the time.
4. Tap **Ok**.

### 2.6.4 Change views in Calendar

You can look at your appointments in Agenda, Day, Week, or Month view. To see detailed appointment information in any view, tap the appointment. To see a list of available actions for an appointment, tap and hold the appointment.

1. Tap  > **Calendar**.
2. Tap **Menu** > **View** and select the view you want.

View	See
Agenda	Your current day's activities at a glance. Upcoming appointments are bold; past appointments are dimmed.
Day	Your schedule for a single day in a day-planner layout.  Free and busy times in time slots of 1/2 hour or 1 hour.
Week	Your schedule for the whole week.
Month	Your free and booked days for a month:   : morning appointment  : afternoon appointment  : morning and afternoon appointments  : all-day event with time not marked free
Year	A calendar for the entire year.

#### Notes

In Month view, a date will appear in red when the Holiday category is assigned to any appointment for that day.

#### Tips

You can also change the view by tapping Agenda, Day, Week, Month, or Year on the menu bar.

To quickly see your appointments for the current day, tap **Start** > **Today**

### 2.6.5 Change the display of the work week.

1. Tap  > **Calendar**.
2. Tap **Menu** > **Options** and do one of the following:
  - To specify the first day of the week, in **First day of week**, tap **Sunday** or **Monday**.
  - To specify the number of days you want to appear in a week, in **Week view**, tap **5-day week**, **6-day week**, or **7-day week**.
3. Tap **Ok**.

### 2.7 Notes

Notes helps you to quickly capture thoughts, questions, reminders, to-do lists, and meeting notes. You can create handwritten and typed notes, record voice notes, convert handwritten notes to text for easy readability, and send notes to others.

Your notes and recordings are displayed in the note list. If you have a long list, tap the sort list (labeled Name by default), and select the option you want. To open a note or play a recording, tap it. To see a list of available actions for a note or recording, tap and hold the note or recording.

#### 2.7.1 Set the default input mode

1. Tap  > **Programs** > **Notes**.
2. Tap **Menu** > **Options**.
3. Select one of the following modes in **Default mode**:
  - Select **Writing** if you prefer your notes to be handwritten.
  - Select **Typing** if you would like your notes to be typed.
4. Tap **Ok**.

#### 2.7.2 Create a note

1. Tap  > **Programs** > **Notes**.
2. Tap **New** and enter text.

3. Tap **Ok** to save your note.

### 2.7.3 Delete a note

1. Tap  > **Programs** > **Notes**.
2. Select the note and tap **Menu** > **Tools** > **Delete**.
3. Tap the **Yes** button to delete the selected note.

### 2.7.4 Create a voice recording

You can create a stand-alone voice recording or add voice recording to a note.

1. Tap  > **Programs** > **Notes**.
2. Do one of the following:
  - If you prefer to create a stand-alone voice recording, record your voice in the notes list.
  - If you prefer to add a voice recording to a note, create a new note or open an existing note from the notes list before recording.
3. Tap **Menu** > **View Recording Toolbar**.
4. Tap the RECORD button on the recording toolbar and speak to the device's microphone.
5. Tap the STOP button on the recording toolbar when finished.
6. Tap **Ok** to return to the notes list if you are adding a voice recording to a note.

## 2.8 Tasks

Use Tasks to keep track of things you need to do. A task can occur once or repeatedly (recurring). You can set reminders for your tasks and you can organize them using categories.

Your tasks are displayed in a task list. Overdue tasks are displayed in red.

If you use Outlook on your PC, you can synchronize tasks between your device and PC so that tasks you create or update on your PC will also be updated on your device and vice versa.

### **Notes**

To quickly see the number of active tasks you have, tap **Start** > **Today**.



### 2.8.1 Create a task

1. Tap  > **Programs** > **Tasks**.
2. In the **Tap here to add a new task** box, enter the task name and press ENTER.

#### **Notes**

You can synchronize information on your phone with your PC to keep your task list up to date in both locations.

If you create a new task with a reminder on your PC and then synchronize tasks with your phone, the reminder will play at the time it was set on your PC.

### 2.8.2 Delete a task

1. Tap  > **Programs** > **Tasks**.
2. Select the task, and tap **Menu** > **Delete**.

### 2.8.3 Change task priority

1. Tap  > **Programs** > **Tasks**.
2. Select the task, and tap **Edit**.
3. In the **Priority** box, select a priority.

### 2.8.4 Sort/Filter your tasks

1. Tap  > **Programs** > **Tasks**.
2. Do one of the following:
  - To sort the tasks, tap **Menu** > **Sort** by and select a sorting option.
  - To Filter the tasks by category, **Menu** > **Filter** and select a category to display.

### 2.8.5 Set Tasks options

1. Tap  > **Programs** > **Tasks**.
2. Tap **Menu** > **Options**, there are 3 options you can set:
  - Set reminders for new items
  - Show start and due dates
  - Show Tasks entry bar

<b>Inventec</b>	Manual	版 本 : 01
	Mercury	日 期 : 95/12/12

<b>Inventec</b>	Manual	版 本 : 01
	Mercury	日 期 : 95/12/12

### Charter 3. Phone Features

Other than the PDA features, you can use your device to place a call, send messages, video and audio files to other mobile phones. This chapter describes the phone features of your device.

### 3.1 Making a call

#### 3.1.1 Make a call by entering a phone number

1. On the Phone keypad screen, begin entering the phone number.
2. Do one of the following:
  - If you see the number or contact name to call, select it and press TALK (📞).
  - If you do not see the number or contact name, finish entering the number and press TALK (📞).

#### 3.1.2 Make a call from Call History

Call History displays call you have made, received, and missed.

1. On the Phone keypad screen, tap the **Call History** button on the Phone keypad.
2. Select the name or phone number to call.
3. Tap **Call** or press TALK (📞).

#### 3.1.3 Make a call from Contacts

1. On the Phone keypad screen, tap **Contacts**.
2. Tap the desired contact and tap **Call** or press TALK (📞) to dial.

#### **Tips**

You can tap on the desired contact in the list and tap on the number you want to dial.

You can also tap and hold the desired contact in the list and select **Call Work**, **Call Home**, or **Call Mobile** from the shortcut menu.

#### 3.1.4 Use a speed dial

On the Phone keypad screen, press and hold the number on the keypad that you have assigned as a speed dial for the phone number, e-mail address, or Web page. If the

speed dial is two digits, press the first digit, and press and hold the second digit. The phone dials the phone number, opens a new e-mail message, or goes to the Web page.

### 3.1.5 Create a speed dial

You can create a speed dial for a phone number, e-mail address, or Web page address that is stored in Contacts.

1. On the Phone keypad screen, tap **Contacts**.
2. Tap the contact for whom to create a speed dial.
3. Select the phone number, e-mail address, or Web page address for which to create a speed dial.
4. Tap **Menu > Add to Speed Dial**.
5. In **Location**, select the speed dial number to use.
6. Tap **Ok** when finished.

#### **Note**

The number 1 is reserved for calling your voice mailbox.

## 3.2 Receiving/Rejecting a call

### 3.2.1 Receive a call

Tap **Answer** or press TALK () to accept an incoming call.

You can also set your phone to answer by pressing any key.

1. Tap  > **Settings**.
2. Tap **Phone > Call Options**.
3. Tap **Call Options**.
4. Select **Any key answer** and tap **Ok**.

### 3.2.2 End a call

Tap **Ignore** or press END () to hang up a call.

### 3.2.3 Block incoming or outgoing calls

You will not be able to receive or make calls according to the options you choose.

1. Tap  > **Settings > Phone > Call Barring**.
2. Choose the calls you want to block, and tap **Ok**.

### 3.3 Call options

#### 3.3.1 Conference Call

1. Either put a call on hold and dial a second number; or accept a second incoming call when you have one in progress.
2. Tap **Conference**.

**Tip**

If the conference connection is successful, the word “Conference” will appear at the top of the screen. To add additional persons to your conference call, tap **Hold**, enter the phone number, and then tap **Resume** to return and continue.

**Note**

Not all service providers support conference calling. Contact your service provider for details.

#### 3.3.2 Call waiting

##### 3.3.2.1 Turn call waiting notifications on and off

When you are in another call, you will be notified of an incoming call if this option is selected.

1. Tap  > **Settings** > **Phone** > **Call Waiting**.
2. Select or clear **Provide call waiting notifications**, and tap **Ok**.

##### 3.3.3.2 Switch between phone lines

On the Home screen, press and hold the # key to switch between phone lines. This feature is available if your phone supports two phone lines.

#### 3.3.3 Turn Speaker On/Off

Talk hands-free or let others hear your conversation with the built-in speakerphone in your device.

- Tap **Speaker On** during a call to turn the speaker on.
- Tap **Speaker Off** to turn the speaker off.

#### 3.3.4 Mute/Unmute the microphone

The device’s microphone can be turned off during a call. If you turn off the microphone the caller cannot hear you. However, you can still hear the caller.

- Tap **Mute** during a call to turn the microphone off.
- Tap **Unmute** to turn the microphone on.

### 3.4 Flight mode

For flight safety reasons, you may be required to turn off your phone by law while traveling on an aircraft. Powering off the device only switches the device to sleep mode. It does not actually turn off the device. You must switch the device to flight mode in order to turn off the phone features.

1. Tap on the signal icon, and tap **Wireless Manager**.



2. Tap on **Phone** to switch to flight mode or to turn off phone features.

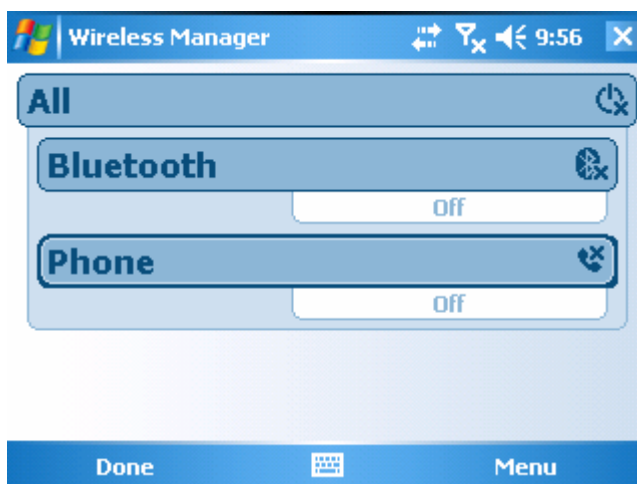

Another way to switch the device to flight mode is using the flight mode shortcut on the Today screen.



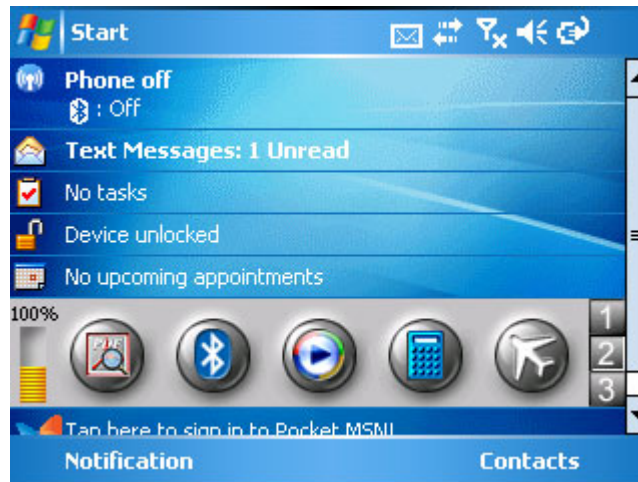

Flight mode on / Phone features disabled

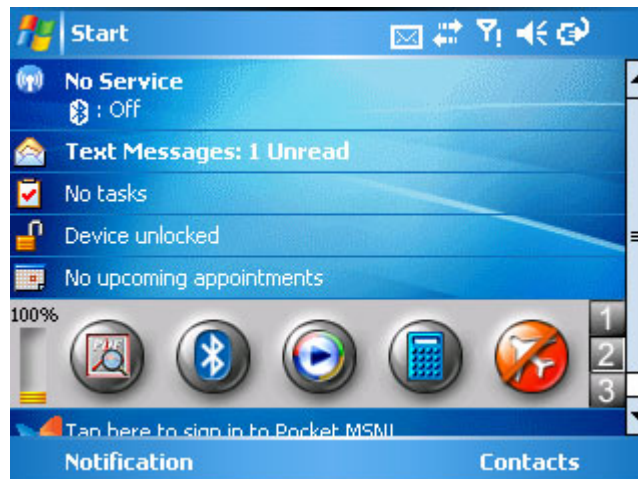

Flight mode off / Phone features enabled

<b>Inventec</b>	Manual	版 本 : 01
	Mercury	日 期 : 95/12/12

<b>Inventec</b>	Manual	版 本 : 01
	Mercury	日 期 : 95/12/12

## Chapter 4. Synchronizing Information

With ActiveSync on both your PC and mobile device, you can synchronize information between a PC or Exchange Server and your device. First, you must install ActiveSync on the PC. Then you can:

- Synchronize information so that you have the latest information in all locations.
- Change synchronization settings and synchronization schedule.
- Copy files between your device and PC.
- Add and remove programs on your device.

Once you install ActiveSync on your PC, you will be prompted to connect your device and create a synchronization relationship with the device by using a cable, cradle, Bluetooth, or infrared connection. While you are setting up this relationship you can choose the information you want to synchronize with either your PC or with Exchange Server.

#### 4.1 Install and set up ActiveSync

1. Install ActiveSync on your PC, as described on the Windows Mobile Getting Started Disc. After Setup completes, the Sync Setup Wizard automatically starts when you connect your phone to the PC.
2. Follow the instructions on the screen to complete the wizard. In the Sync Setup Wizard, you can:
  - Create a synchronization relationship between your PC and the device.
  - Configure an Exchange Server connection to synchronize directly with Exchange Server. To synchronize your device with Exchange Server, obtain the name of the Exchange Server, your user name, password, and domain name from your administrator before completing the wizard.
  - Choose information types to synchronize.

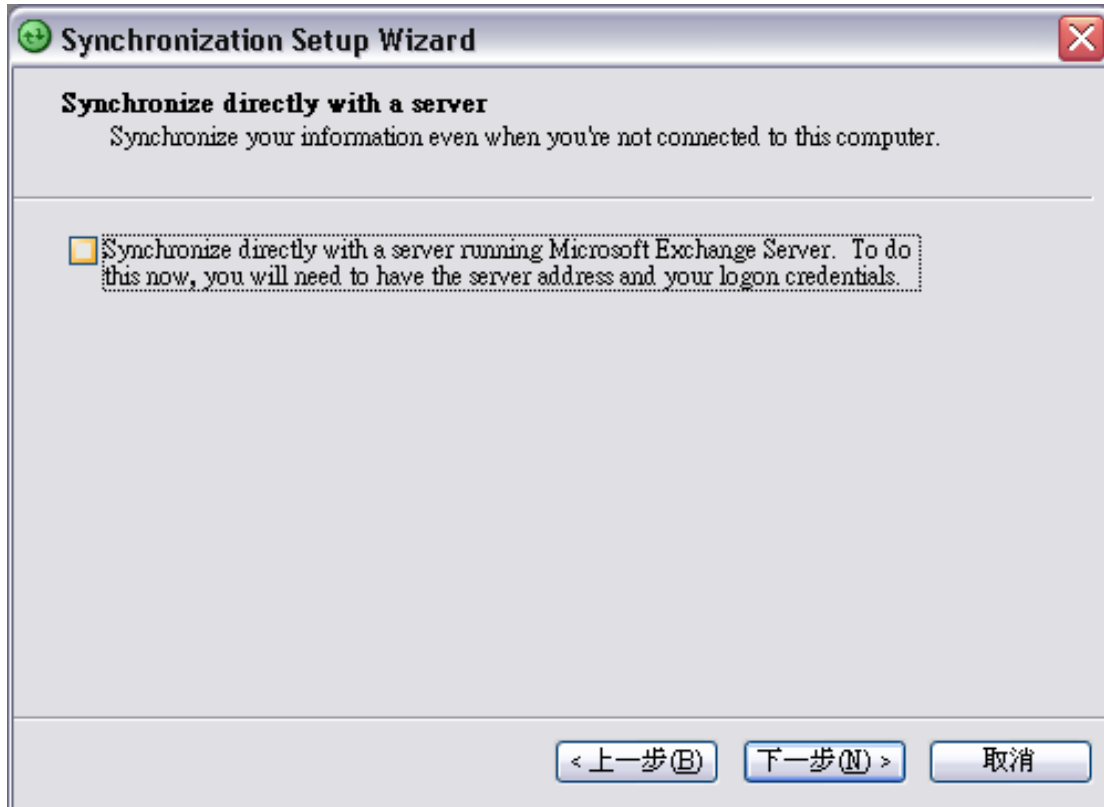
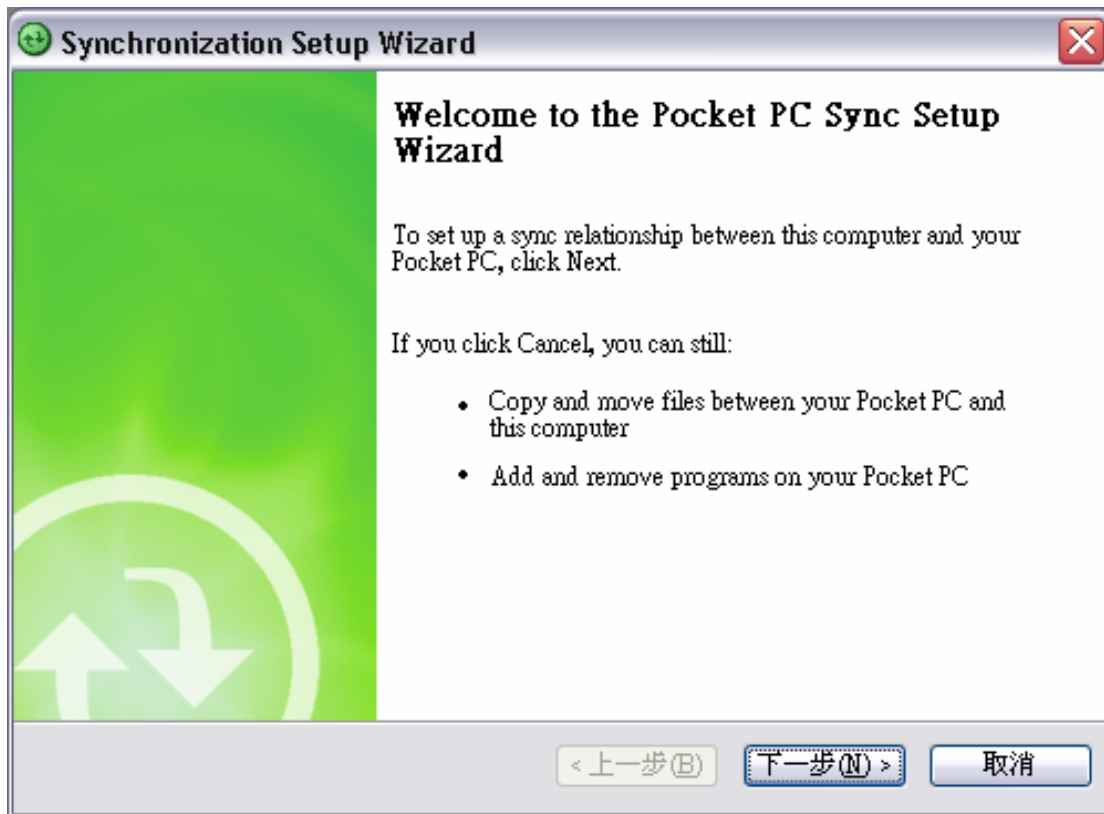

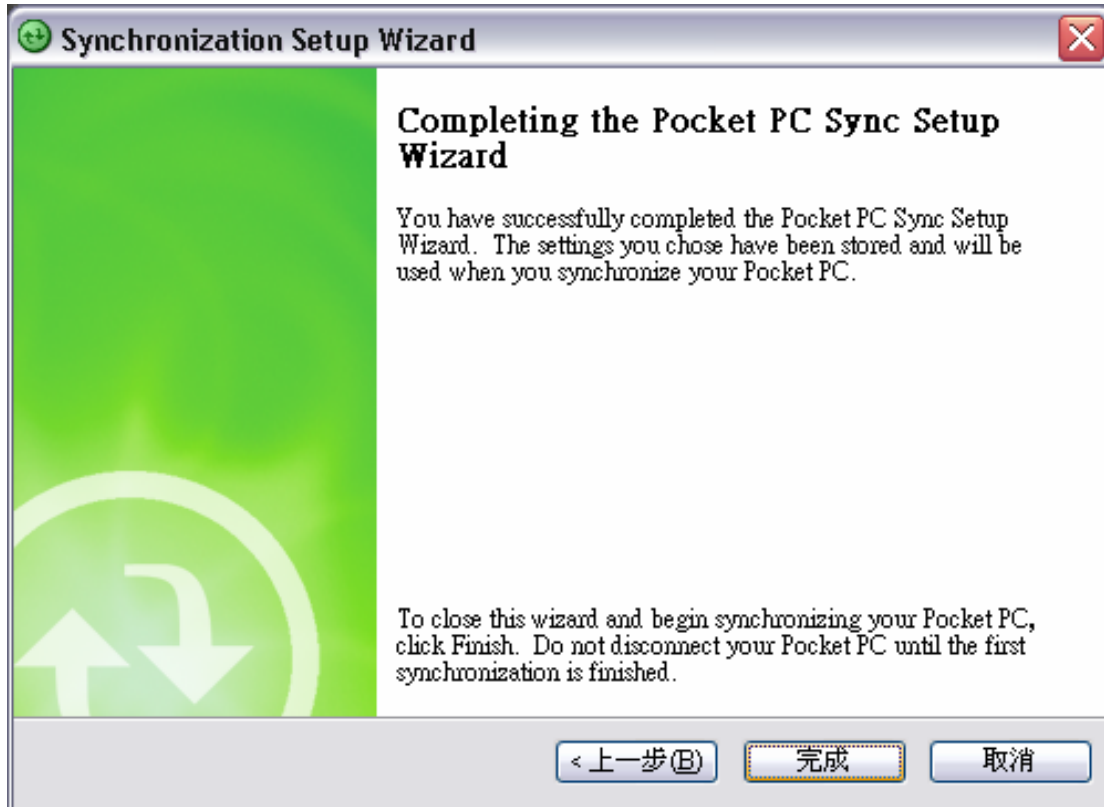
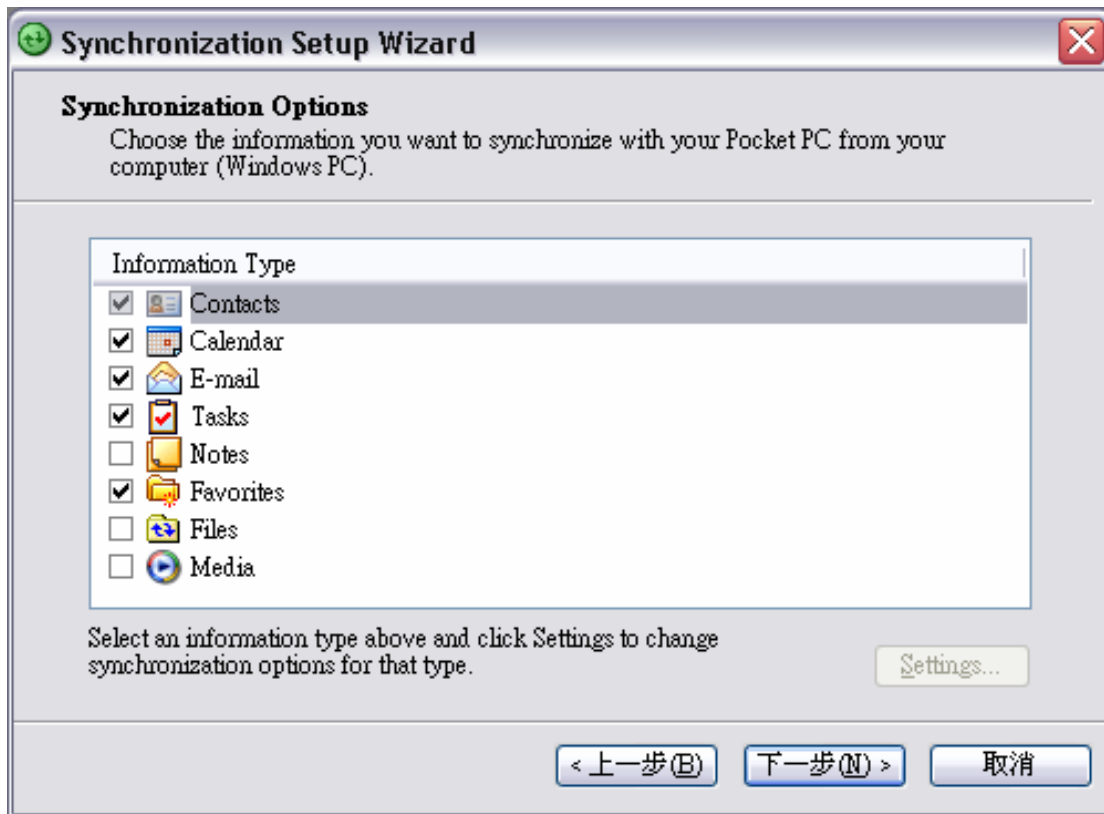

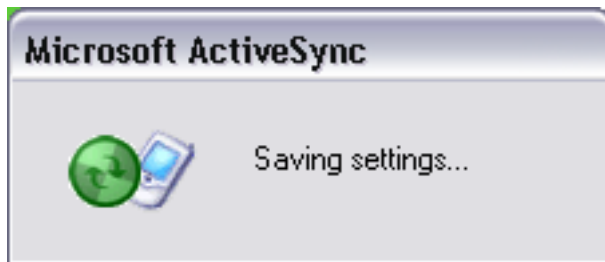
**Note**

When you finish the wizard, ActiveSync synchronizes your phone automatically. Once synchronization completes, you can disconnect your phone from your PC.

#### 4.2 Connect the device

**Important note**

To synchronize using ActiveSync, you must install ActiveSync on your PC before connecting your device to the PC.

1. Turn on the device.
2. Connect your device to your PC using a serial cable, USB cable, Bluetooth, or infrared connection. For more detailed information, see "Connecting a mobile device to a PC" in ActiveSync Help on your PC.

#### 4.3 Start and stop synchronization

1. Tap  > **Programs** > **ActiveSync**.
2. To start synchronization, tap **Sync**.
3. To stop synchronizing, tap **Stop**.

**Note**

You can start and stop synchronization only if your device already has a sync relationship with a PC or Exchange Server.

#### 4.4 Change ActiveSync settings

Once you set up synchronization using the Sync Setup wizard on the PC, you can later

change your synchronization settings:

- If you want to change ActiveSync settings for synchronizing with a PC, use ActiveSync on the PC. For more information, see "Changing the amount of information synchronized" in ActiveSync Help on the PC.
- If you want to change ActiveSync settings for synchronizing with Exchange Server, use ActiveSync on your phone, as described in "Change settings for an information type."

#### 4.5 Change settings for an information type

**Note**

Before changing synchronization settings on the device, disconnect it from your PC.

1. Tap  > **Programs** > **ActiveSync** > **Menu** > **Options**.
2. Select one of the information types.
3. Do one of the following:
  - To view or change settings for an information type (when available), tap **Settings**.
  - To view or change settings for a computer or Exchange Server, tap **Menu** > **Settings**.
4. Change the amount of information to be synchronized or other settings.
5. Tap **Ok** (or **Finish** in the Exchange Server settings wizard).

#### 4.6 Set up an Exchange Server connection

To complete this configuration, you will need to get the name of the server and the server domain name from your service provider or system administrator. You must also know your Exchange user name and password.

**Note**

Before changing synchronization settings on the device, disconnect it from your PC.

1. On your device screen, tap  > **Programs** > **ActiveSync** > **Menu** >



**Configure Server.** If you have not yet set up sync with Exchange Server, this will say Add Server Source.

2. In **Server address**, enter the name of the server running Exchange Server, and tap **Next**.
3. Enter your user name, password, and domain name, and tap **Next**.
4. If you want the device to save your password so that you will not need to enter it again when connecting, select the **Save password** check box.
5. Select the check boxes for the types of information items that you want to synchronize with Exchange Server.
6. To change available synchronization settings, select the type of information, and tap **Menu > Settings**.
7. To change the rules for resolving synchronization conflicts, tap **Menu > Advanced**.
8. Tap **Finish**.

#### 4.7 Connect to a PC using infrared

1. Follow the instructions in ActiveSync Help on the PC for setting up your PC to receive infrared beams.
2. Line up the infrared (IR) ports so that they are unobstructed and within close range.
3. Tap  > **Program > ActiveSync**.
4. Tap **Menu > Connect via IR**.
5. Tap **Sync**.

#### 4.8 Connect to a PC using Bluetooth

1. Follow the instructions in ActiveSync Help on the PC for configuring Bluetooth on your PC to support ActiveSync.
2. Tap  > **Programs > ActiveSync**.
3. Tap **Menu > Connect via Bluetooth**. Ensure that the device and PC are within close range.
4. If this is the first time you have connected to this PC via Bluetooth, you must complete the Bluetooth wizard on the phone and set up a Bluetooth partnership with the PC before synchronizing.
5. Tap **Sync**.
6. When finished, tap **Menu > Disconnect Bluetooth**.
7. To preserve battery power, turn off Bluetooth.



<b>Inventec</b>	Manual	版 本 : 01
	Mercury	日 期 : 95/12/12

## **Chapter 5. Bluetooth/Infrared Connections**

### 5.1 Overview of Bluetooth

Bluetooth is a short-range wireless communications technology. Devices with Bluetooth capabilities can beam (exchange information) over a distance of about 10 meters (30 feet) without requiring a physical connection.

Unlike infrared, you don't need to line up the devices to beam information with Bluetooth. You can even beam information to a device in a different room, as long as it's within range.

You can use Bluetooth as follows:

- Beam information, such as files, appointments, tasks, and contact cards, between devices that have Bluetooth capabilities.
- Create a connection between your device and a Bluetooth phone to use the phone as a modem.

### 5.2 Sending/Receiving beamed information

#### 5.2.1 Turn Bluetooth on and off

By default Bluetooth is turned off. If you turn it on, and then turn off your device, Bluetooth also turns off. When you turn on your device again, Bluetooth turns on automatically.

1. Tap  > **Settings** > **Connections** > **Bluetooth**.
2. Check or uncheck the checkbox in front of **Turn on Bluetooth** to turn on or off Bluetooth.

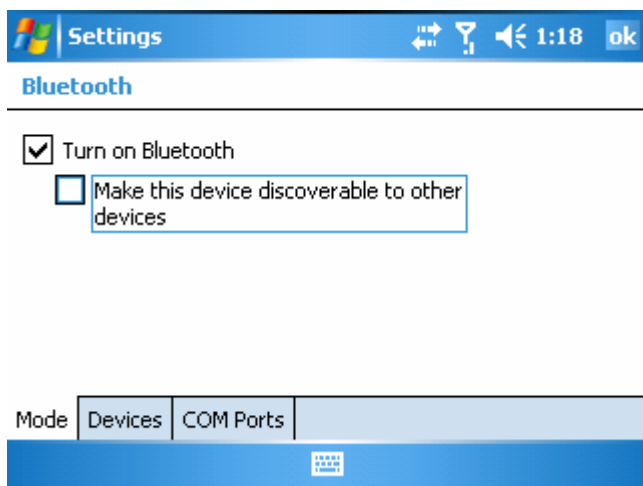

### 5.2.2 Make your device discoverable

To receive beamed information, beaming devices or computers must be able to detect your device.

1. Tap  > **Settings**.
2. Tap **Connections** > **Bluetooth**.
3. Select **Make this device discoverable to other devices**, and tap **Ok**.

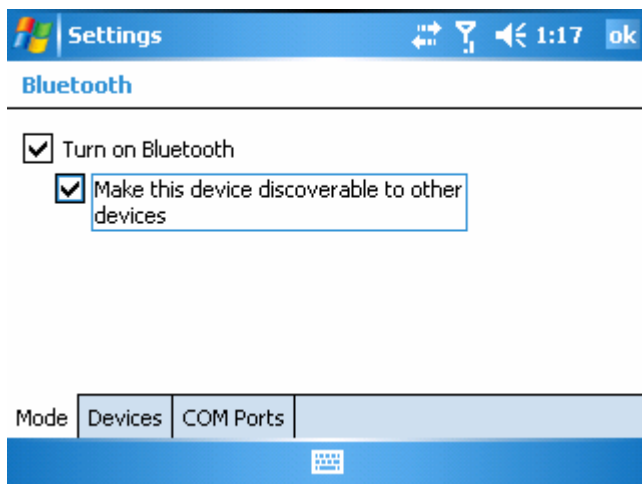

Other Bluetooth-enabled devices can now detect your phone and attempt to beam information to it, establish a Bluetooth partnership, or use a Bluetooth service.

#### Notes

Selecting Discoverable also turns on Bluetooth.

Turning off Bluetooth will make your device not discoverable, and it will also prevent you from sending a Bluetooth beam.

### 5.2.3 Create a Bluetooth partnership

Ensure that the two devices are within close range and that both Bluetooth-enabled devices are discoverable.

1. Tap  > **Settings** > **Connections** > **Bluetooth**.
2. Tap **Menu** > **Devices** > **New Partnership**. Your device searches for other Bluetooth-enabled devices and displays them in the list.

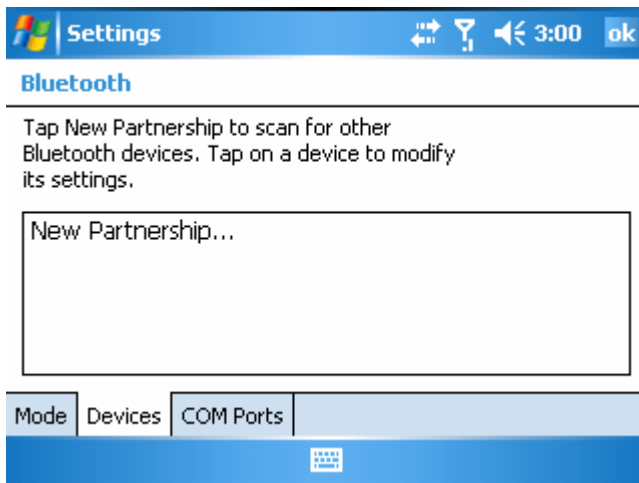

3. Select the device with which you want to create a Bluetooth partnership, and tap **Next**.

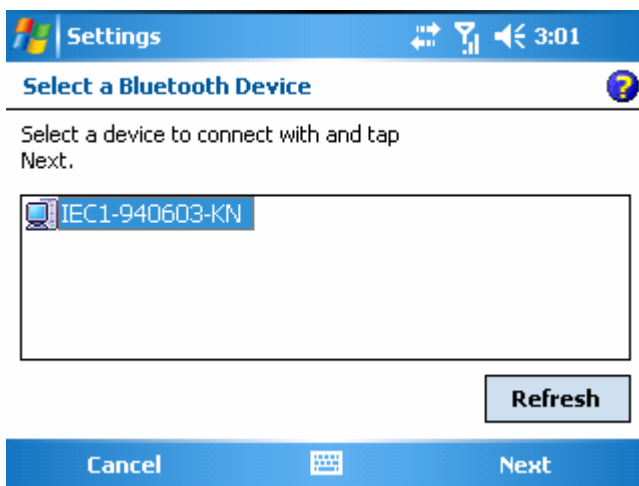

4. In Passkey, if you want to use a passkey (recommended for enhanced security), enter an alphanumeric passkey between 1 and 16 characters, and tap **Next**. Otherwise, leave the passkey blank.

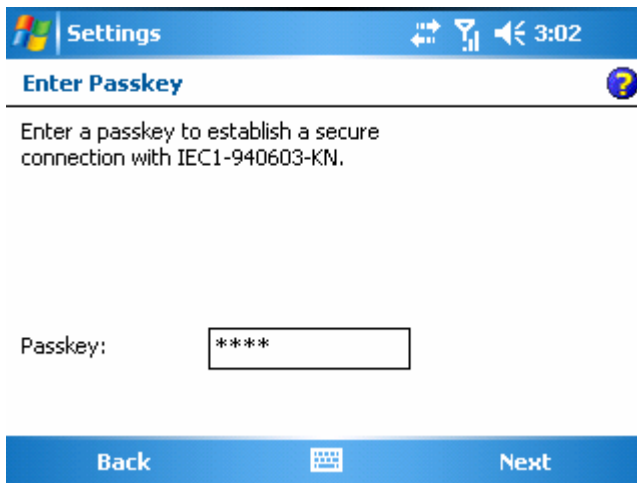

5. Select the service to use from the device, and tap **Finish**.

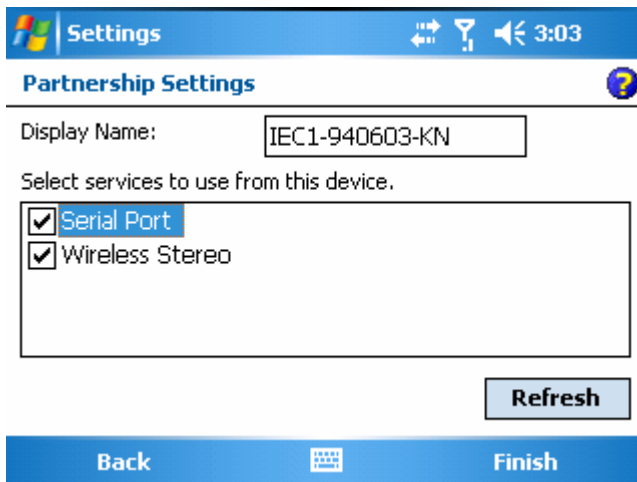

6. Enter the same passkey on the other device.

### Tip

Once you create a partnership, the Bluetooth-enabled devices don't need to be discoverable to beam information between them; Bluetooth needs only to be turned on.

#### 5.2.4 Receive beamed information (Bluetooth & Infrared)

1. Tap  > **Settings**.
2. Tap **Connections** > **Beam**.

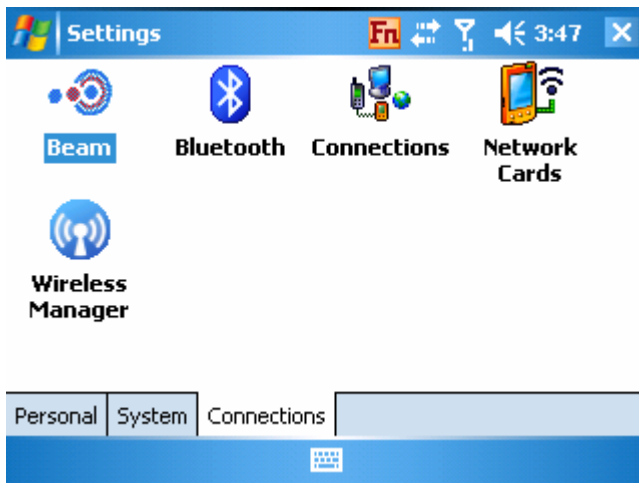

3. Select **Receive all incoming beams**.

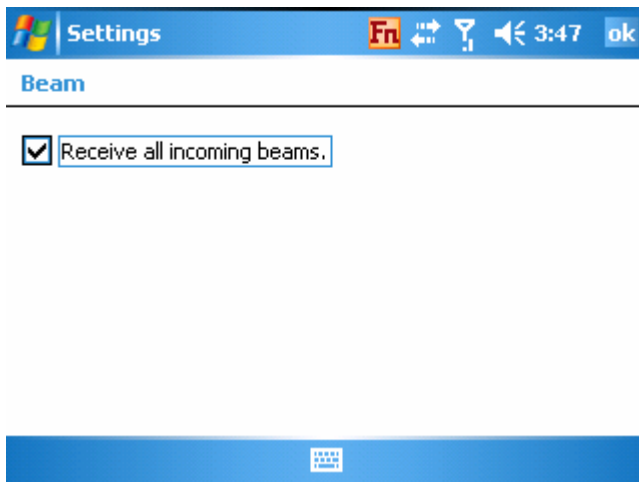

4. Do one of the following:
  - To receive beams by using infrared, align the infrared (IR) ports so that they are unobstructed and within close range of each other.
  - To receive beams by using Bluetooth, ensure Bluetooth is turned on and that your phone is discoverable and within close range.
5. Tap **Yes**.



**Notes**

Once you select Receive incoming beams, your phone automatically receives beams until you clear this check box.

Your phone can receive all types of beamed files, but you may not be able to view all types of files on the phone. You may need to copy some files to a PC for viewing.

### 5.2.5 Beam an item (Bluetooth & Infrared)

In the Calendar, Contacts, Notes, Tasks, and Pictures programs, you can beam files and information to other devices using Bluetooth or infrared.

1. From the program, select the item you want to beam, such as an appointment in Calendar, a task in Tasks, a contact card in Contacts, a picture in Pictures, a file in File Explorer. In Calendar, first open the appointment in Agenda view.
2. Tap **Menu > Beam [type of item]**.
3. Do one of the following:
  - If using Bluetooth, select the device to which you want to send the item.
  - If using infrared, align the infrared (IR) ports at close range until the target device name appears, and then select the device to which you want to send the item.
4. Tap **Beam**.

**Tip**

When using Bluetooth, if the device that you want to beam to doesn't appear in the list, ensure that the device is turned on, discoverable, and within close range of your phone. Also, ensure that Bluetooth is turned on.

<b>Inventec</b>	Manual	版 本 : 01
	Mercury	日 期 : 95/12/12

<b>Inventec</b>	Manual	版 本 : 01
	Mercury	日 期 : 95/12/12

## Chapter 6. Transferring files to your device

You may need to transfer application data such as Word documents, Excel spreadsheets, PowerPoint slides, and/or media files from your PC to your device. This section describes different methods to transfer files from a PC to your device.

#### 6.1 Using ActiveSync to transfer files

##### Note

To transfer files from PC to your device with ActiveSync, you must install Microsoft ActiveSync on the PC first. Please refer to Chapter 4 Synchronizing Information for detail on how to install and set up ActiveSync.

1. Connect your device to the PC with the USB cable. Microsoft ActiveSync should be automatically launched on the PC if it is set up correctly.
2. Select **Files** under Synchronization Options in the Synchronization Setup Wizard by checking the checkbox in front of Files.

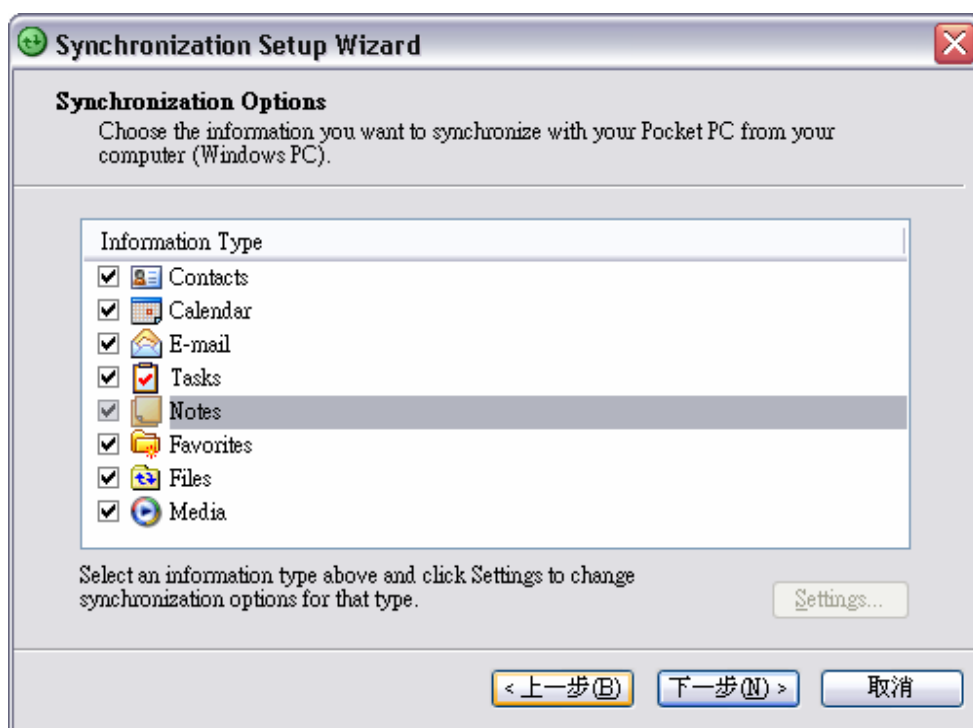

3. Click the **Settings** button and add the files you want to transfer. Click the **OK** button when you finish.

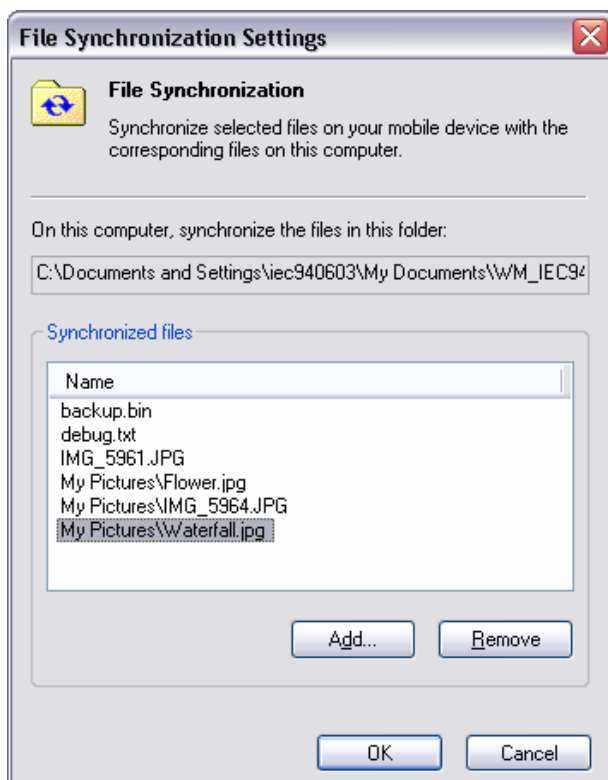

4. Click **Next**, and then click **Finish** to start the synchronization process.
5. On your device, tap  > **Programs** > **Pictures & videos**. The files should be saved to **My Pictures**. Check to see if the files have been transferred to your device successfully.

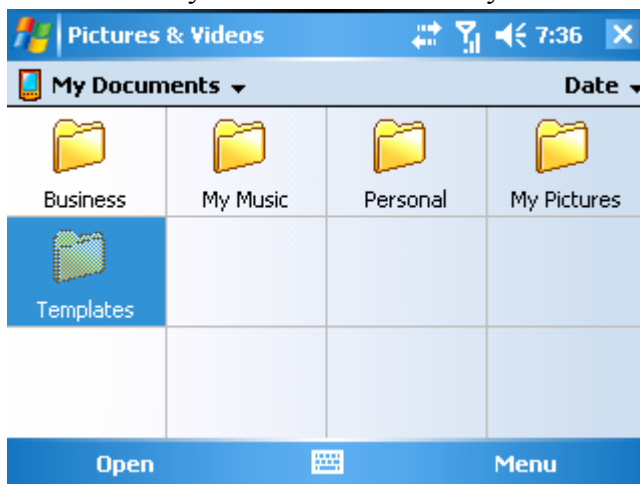

### 6.2 Transferring files from memory cards

1. Insert your memory card into the device's mini-SD card slot. (See "1.5 Mini-SD cards" for details.)
2. Tap  > **Programs** > **File Explorer**.

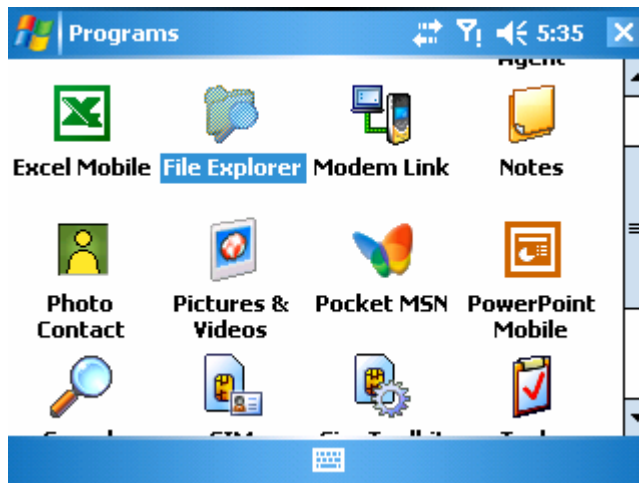

- In the Show list, select **Storage Card**.

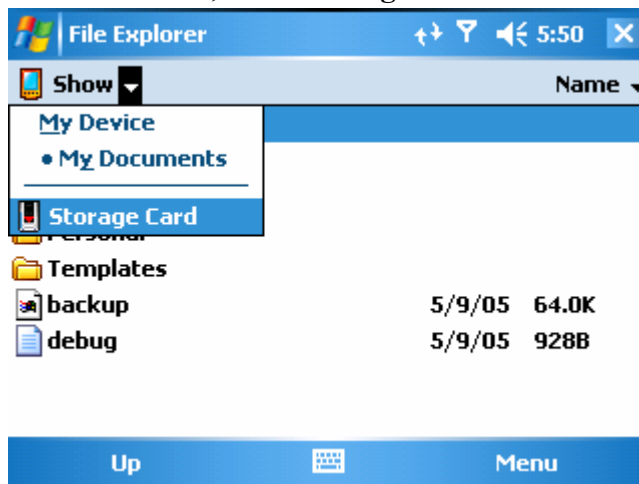

- File Explorer should display all the files stored in your memory card. Tap and hold the file you want to transfer, and select **Copy**.
- From the Show list in File Explorer, go to destination folder. (For example, **My Device > My Documents > My Pictures**.)
- Tap **Menu > Edit > Paste**.

### 6.3 Using infrared to transfer a file

#### Note

Before receiving files, you must make your device capable of receiving incoming beams by tapping  > **Settings > Connections > Beam** and check the checkbox in front of **Receive all incoming beams**.

1. Align the infrared port on your device with the infrared port on your PC so that they are unobstructed and within close range.
2. After your PC detects a new infrared connection, select a file to send to your device and click the **Send** button.
3. Tap **Yes** when your device prompts about receiving a file.
4. On your PC, you can see the file transmission information such as the filename and percentage.

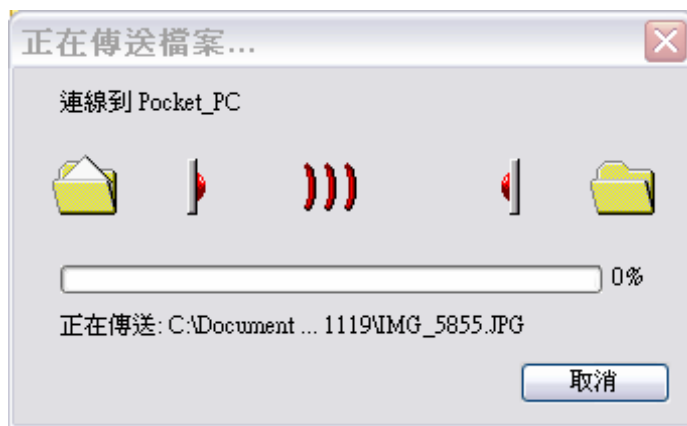

5. After the transmission process is finished, the file should be saved in your device under My Documents in the File Explorer.

#### 6.4 Using Bluetooth to transfer a file

**Note**

Before receiving files, you must turn Bluetooth on and establish a Bluetooth partnership between your PC and your device. (See “Chapter 5. Bluetooth/Infrared Connections” for details.)

1. On your PC, locate the file you want to send using Bluetooth with Windows Explorer.
2. Right-click the file and select the device you want to transfer the file to under “to Bluetooth.”

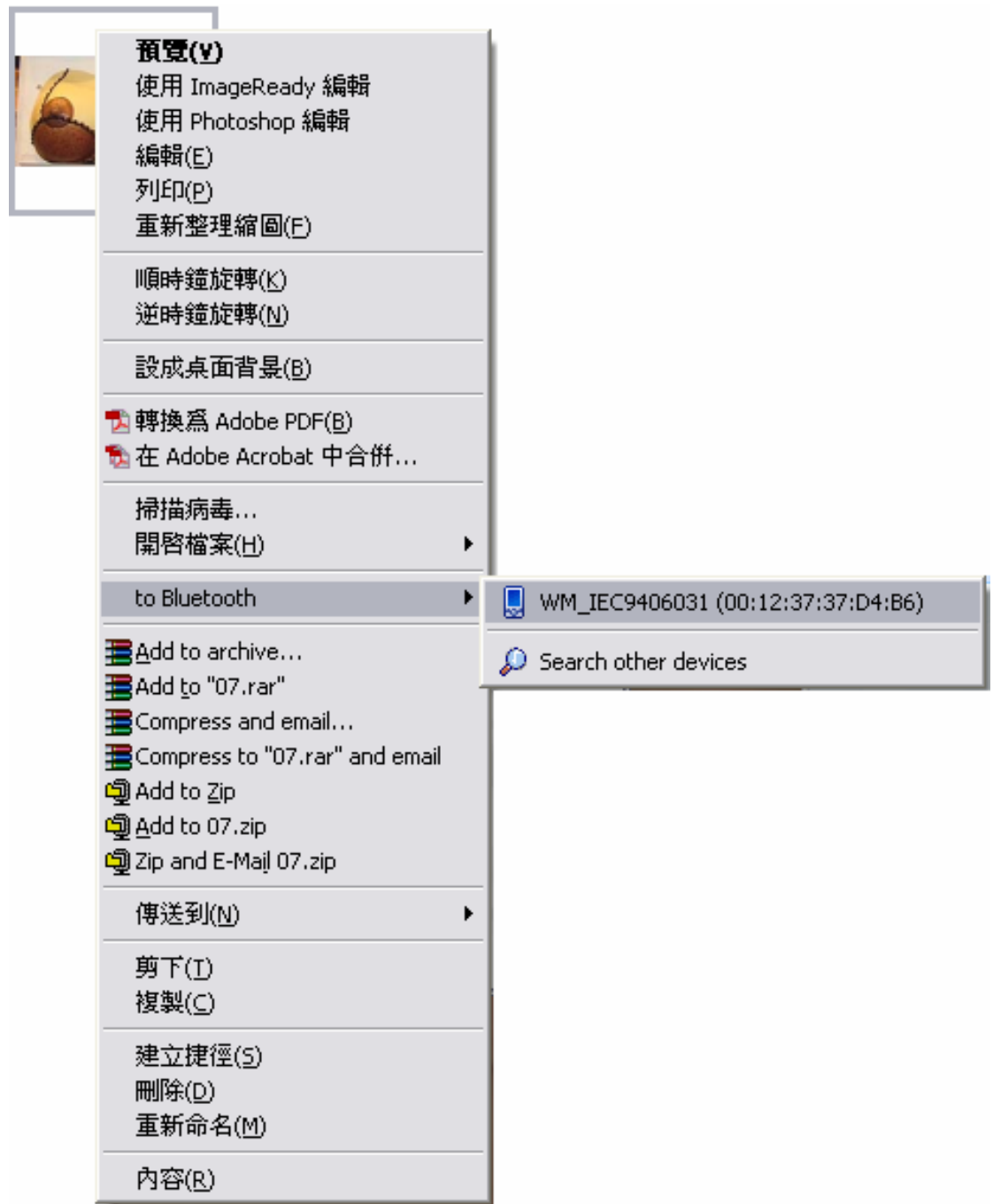

3. Tap **Yes** when your device prompts about receiving a file.



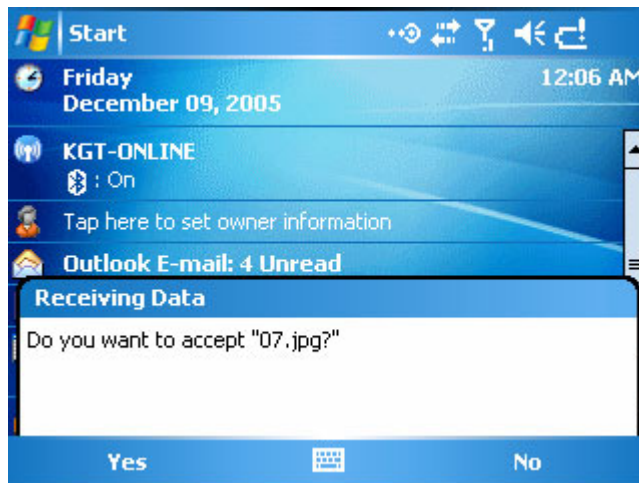

4. After the transmission process is finished, the file should be saved in your device under My Documents in the File Explorer.



<b>Inventec</b>	<b>Manual</b>	版 本 : 01
	Mercury	日 期 : 95/12/12

## **Chapter 7. Setting up Internet Connection**

You can connect to the Internet with your device through a Global Packet Radio Service (GPRS) network or a proxy server. This chapter describes how to setup such connections so you can surf the Internet with you device.

### 7.1 Create a GPRS connection

Every network connection is different. You should gather all of the relevant information or network settings you need before starting this process.

1. Tap  > **Settings** > **Connections** > **Connections**.
2. Tap **Add a new modem connection**.



3. Enter the following information (you may or may not need to enter all of the following information), and tap **Finish**.
  - Enter a name for the connection.
  - In **Select a modem**, select **Cellular Line (GPRS)**.

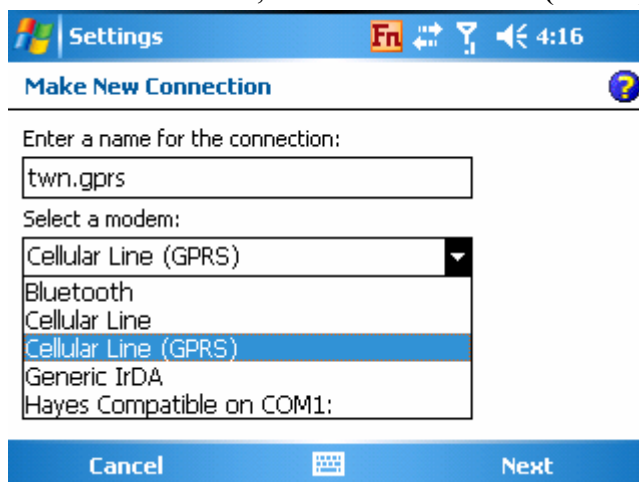

- In Access point, enter the access point name.

Settings Fn 4:17

twn.gprs

Access point name:  
internet

Back Next

- In User name, enter your user name for the GPRS network, if required.
- In Password, enter your password, if required.

Settings Fn 4:18

twn.gprs

User name:

Password:

Domain:\*

\* If provided by ISP or network administrator.

Advanced...

Back Finish

- In Primary DNS, enter the primary Domain Name System (DNS) address, if required.
- In Secondary DNS, enter the secondary DNS address, if required.
- In IP address, enter the Internet Protocol (IP) address for the device, if required.

The phone uses this connection when you open a program that connects to the Internet.

### 7.2 Create a proxy connection

Every network connection is different. You should gather all of the relevant

information or network settings you need before starting this process.

1. Tap  > **Settings** > **Connections** > **Connections**.
2. Tap **Set up my proxy server**.



3. Check the checkbox in front of **This network connects to the Internet**.
4. Check the checkbox in front of **This network uses a proxy server to connect to the Internet**.
5. Under Proxy server, enter the proxy server name.

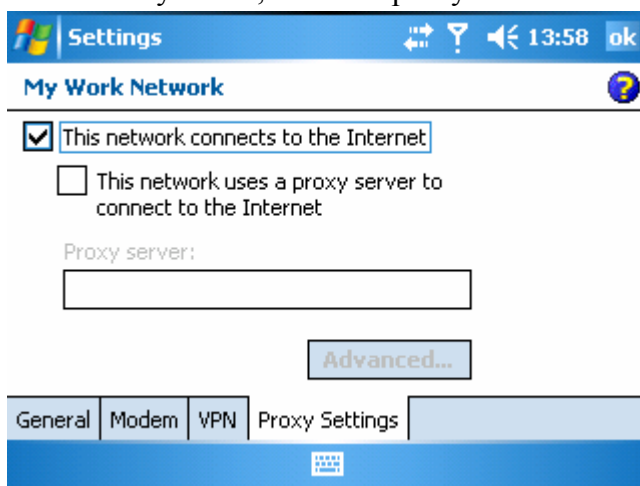

6. If the proxy server uses a different port or requires a username and password tap **Advanced**, select the proxy type to change its settings, then enter username, password and/or port number in the proper fields.
7. Tap **Ok**.

### 7.3 Delete a connection

1. Tap  > **Settings** > **Connections**.

<b>Inventec</b>	<b>Manual</b>	版 本 : 01
	Mercury	日 期 : 95/12/12

2. Tap **Manage existing connections**.
3. Tap and hold on the connection you want to delete and select **Delete**.

<b>Inventec</b>	Manual	版 本 : 01
	Mercury	日 期 : 95/12/12





<b>Inventec</b>	<b>Manual</b>	版 本 : 01
	Mercury	日 期 : 95/12/12

## **Chapter 8. Internet Explorer**



Internet Explorer is a full-featured Web browser. You can use Internet Explorer to browse the Internet once you have set up your Internet connection (if you haven't done so, please read the previous chapter before continuing.)

### 8.1 Browsing the Internet

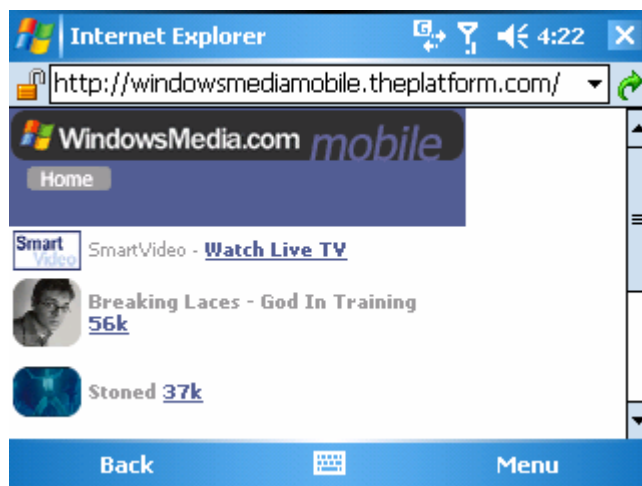
1. To browse the Internet you must have a valid connection established.
2. Tap  > **Internet Explorer**.
3. Do either of the following:
  - Enter the address in the address bar, and tap .
  - Tap **Favorites** then select a favorite, and tap .



### 8.2 Add a Web page to the Favorite list

1. Tap  > **Internet Explorer**.
2. To go to the page you want to add, tap **Menu** > **Address Bar**, enter the address, and tap .
3. Tap **Menu** > **Add to Favorites**.
4. Confirm or change the name and Web page address.
5. In Folder, select a folder for this favorite.
6. Tap **Add**.

#### Tip

A quick way to add favorites to your phone is to synchronize with your PC using ActiveSync. For more information, see ActiveSync Help on your PC.

### 8.3 Delete a favorite

1. Tap  > **Internet Explorer**.
2. Tap **Favorites**.
3. Select the favorite to delete.
4. Tap **Menu** > **Delete**.
5. Tap **Yes** to confirm the deletion.

### 8.4 Change the size of text on Web pages

1. Tap  > **Internet Explorer**.
2. Tap **Menu** > **Zoom** and select the size you want.

### 8.5 Show or hide pictures on Web pages

1. Tap  > **Internet Explorer**.
2. Tap **Menu** > **View** > **Show Pictures**.

A check mark next to Show Pictures indicates that pictures will be displayed.

### 8.6 Change Web page display options

1. Tap  > **Internet Explorer**.
2. Tap **Menu** > **View**.
3. Select one of the following:
  - **One Column**. Arranges the content into one column that is as wide as the screen. This means that you will rarely have to scroll horizontally.
  - **Default**. Maintains a layout similar to what you see on a desktop computer, but makes items smaller and arranges the content so that you can see most of it without having to scroll horizontally.
  - **Desktop**. Keeps the same layout and size as on a desktop computer, which will require both horizontal and vertical scrolling.

### 8.7 Clear history, cookies, or temporary files

1. Tap  > **Internet Explorer**.
2. Tap **Menu** > **Tools** > **Options**.
3. Tap **Memory**.
4. Select the type of memory to clear.
5. Tap **Clear**, tap **Yes**, and then tap **Ok**.

### 8.8 View a page in full screen mode

1. Tap  > **Internet Explorer**.
2. Tap **Menu** > **View** > **Full Screen**.

**Tip**

To exit full screen mode, press either SOFT KEY, and then tap **Menu** > **View** > **Full Screen** to cancel the selection.

<b>Inventec</b>	Manual	版 本 : 01
	Mercury	日 期 : 95/12/12

<b>Inventec</b>	Manual	版 本 : 01
	Mercury	日 期 : 95/12/12

## Chapter 9. Messaging & Contact

Messaging is the center of all messages in your device. With Messaging, you can send and receive text messages, e-mails, and MMS messages.

Contacts helps you to manage your contact information. Using Contacts you can quickly communicate with people.

This section describes the procedure on sending and receiving different kinds of messages, and using Contacts to manage addresses and phone numbers.

## 9.1 Text messages

### 9.1.1 Create a text message

1. Tap  > **Messaging**.
2. In the message list, tap **Menu** > **Switch Accounts** > **Text Messages**.
3. Tap **New**.
4. Enter the recipient's text message number in the **To** field. Insert a semicolon (;) between multiple text message numbers.
5. Enter your message and tap **Send**. Text messages are sent immediately.

#### **Tip**

You can quickly enter text message numbers from your contact cards. In **To**, press **ENTER** and select a recipient from the list. Then, select the recipient's phone number.

### 9.1.2 Using preset text messages

You can quickly insert preset or frequently used messages into your text message. While composing a message, tap **Menu** > **My Text** and select a preset message to insert.

To edit a preset message:

1. While composing a message, tap **Menu** > **My Text** > **Edit My Text Messages**.
2. Select a message and edit.
3. Tap **Ok**.

### 9.1.3 Read a text message

1. Tap  > **Messaging**.
2. Tap **Inbox** and select Inbox under Text Messages.
3. In the message list, tap the text message you want to read.

### 9.1.4 Message options

1. Tap  > **Message**, and select **Text Messages** account.
2. Tap **New**.
3. Tap **Menu** > **Message Options**.
4. Select the type of options to change.
5. Tap **Ok**.

## 9.2 Multimedia Messaging Service

### 9.2.1 Set up a MMS account

1. Tap  > **Message**.
2. Tap **Menu** > **Switch Accounts** > **MMS**.

### 9.2.2 Compose a MMS message

MMS messages can be composed in a combination of various slides where each slides can be any combinations of audio or video clip, an image, and/or text.

1. Tap  > **Message**.
2. Tap **Menu** > **Switch Accounts** > **MMS**.
3. Tap **New**.
4. In **To**, **Cc**, and/or **Bcc**, enter recipient e-mail addresses. Insert a semicolon (;) between multiple addresses.
5. In **Subj**, enter a subject.
6. To create a slide, do any combinations of the following:
  - Tap **Insert Picture/Video** and select a picture or video clip.
  - Tap **Insert Audio** and select an audio clip.
  - Tap **Insert Text** and enter a message.
  - Tap **Menu** > **Insert** > **Sound Recorder** and tap RECORD ( ) button to record a new audio clip. Tap STOP ( ) button to stop recording.
  - Tap **Menu** > **Options** > **Background** and select a background color for the slide.
7. Tap **Send**.



**Tip**

After the first slide is filled with content, you can tap **Menu > Slides > Insert** to add another slide to your MMS message.

9.2.3 Read a MMS message

4. Tap  > **Messaging**.
5. Tap **Inbox** and select Inbox under MMS.
6. In the message list, tap the text message you want to read.

9.2.4 Preview a MMS message

You can preview a MMS message before sending it.

1. To preview your MMS message, tap **Menu > Preview** after you composed your message.
2. Tap **Done** or **Replay**.

9.2.5 Configure MMS settings

1. Tap  > **Message**.
2. Tap **Menu > Switch Accounts > MMS**.
3. Tap **New**.
4. Tap **Menu > Options > MMS Settings**.
5. Select the type of options to change.
6. Tap **Ok**.

9.3 Outlook E-mail

9.3.1 Set up an Internet e-mail account manually

Before you set up your Internet e-mail account, please ensure that you have the necessary information.

<b>Setting</b>	<b>Description</b>
User name	Usually the first part of your e-mail address, which appears before the at sign (@).
Password	Choose a strong password. You will have the option to save your password, so that you do not need to enter it each time you connect to your e-mail server.

Domain	The domain name. This may be required.
Server type	The type of e-mail server that hosts your mailbox (POP3 or IMAP4).
Account name	A name for this account. You must use a different name for each account that you set up.
Network	The type of network your e-mail server connects to.
Incoming mail server	The name of your e-mail server (POP3 or IMAP4).
Require SSL connection	Select this to ensure you always receive e-mail for this account using an SSL connection. This enables you to receive personal information more securely. Please note that if you select this and your ISP does not support an SSL connection, you will not be able to connect to receive e-mail.
Outgoing mail server	The name of your outgoing e-mail server (SMTP).
Outgoing server requires authentication	Your outgoing e-mail server (SMTP) may require authentication. Note: Your user name and password from above will be used.
Outgoing server settings	Your outgoing e-mail server may require different authentication settings than your incoming e-mail server.
Use different user name for outgoing server	A check box that lets you enter separate settings for your outgoing e-mail server.
User name	Your user name for the outgoing e-mail server.
Password	Your password for the outgoing e-mail server.
Domain	The domain name of the outgoing e-mail server.
Require SSL connection (Outgoing mail server only)	A connection that enables you to send personal information more securely. Note that if you select this and your ISP does not support an SSL connection, you will not be able to send e-mail.

Now you are ready to set up your account.

1. Tap  > **Messaging**.
2. Tap **Menu** > **Tools** > **New Account**.
3. Enter your e-mail address and tap **Next**.
4. On the **Auto configuration** setup page, tap **Next**. Auto configuration

attempts to obtain necessary e-mail server settings from your service provider.

5. If auto configuration was successful, the **Your name** and **User name** is automatically filled out for you. Tap **Next** and then tap **Finish** to complete the account setup. If auto configuration was not successful, enter information above appropriate until setup is complete.

**Tip**

Enter a name that you want to display when you send e-mail in the **Your name** field.

**Caution**

If you save your password and then lose your phone, someone finding your phone might be able to gain access to your e-mail.

### 9.3.2 Compose an e-mail message

1. Tap  > **Messaging**.
2. Select an e-mail account.
3. Tap **New**.
4. In **To**, **Cc**, and/or **Bcc**, enter recipient e-mail addresses. Insert a semicolon (;) between multiple addresses.
5. In **Subj**, enter a subject.
6. Enter a message.
7. Tap **Send**. E-mail messages are stored in Outbox and are sent to recipients the next time you synchronize or connect to your e-mail server and send and receive mail.

**Tip**

You can quickly enter e-mail addresses from your contact cards. In **To**, press ENTER and select a recipient from the list. Then, select the recipient's e-mail address.

To set the e-mail priority, tap **Menu** > **Message Options**.

### 9.3.3 Read an Outlook E-mail message

1. Tap  > **Messaging**.
2. Tap **Inbox** and select Inbox under Outlook E-mail.
3. In the message list, tap the text message you want to read.

### 6.3.4 Message options

1. Tap  > **Message**, and select **Outlook** account.
2. Tap **New**.
3. Tap **Menu** > **Message Options**.
4. Select the type of options to change.
5. Tap **Ok**.

### 9.4 Change Messaging account options

1. Tap  > **Message**, and select the Messaging account you want to change options for.
2. Tap **Menu** > **Tools** > **Options**.
3. Select the type of options to change.
4. Tap **Ok**.

## 9.5 Contacts

### 9.5.1 Create a new contact

1. Tap  > **Contacts** > **New**.
2. Enter information for the new contact.
3. Tap **Ok**.

#### **Tips**

If someone who isn't in your list of contacts calls you or sends you a message, you can create a contact from Call History or from the message by tapping **Menu** > **Save to Contacts**.

To save an existing contact to your SIM, open the contact and tap **Menu** > **Save to SIM**.

### 9.5.2 View and edit contact information

1. Tap  > **Contacts**.

2. Tap the contact whose information you want to view.
3. To edit the information, tap **Menu > Edit**.
4. When finished making changes, tap **Ok**.

#### 9.5.3 Add a picture to a contact

1. Tap  > **Contacts**.
2. Tap the contact you want to add a picture to.
3. Tap **Menu > Edit**.
4. Tap **Picture**.
5. Tap the picture you want to add.

#### 9.5.4 Assign a ring tone to a contact

To easily identify who is calling you by the ring tone, you can assign a custom ring tone to each contact.

1. Tap  > **Contacts**.
2. Tap the contact you want to assign a ring tone to.
3. Tap **Menu > Edit**.
4. Tap **Ring tone** and select the ring tone you want.
5. Tap **Ok**.

#### 9.5.5 Find a contact

1. Tap  > **Contacts**.
2. Begin entering the name or phone number of the contact until the contact is displayed.

**Note**

SIM contacts appear at the bottom of the contacts list in alphabetical order.

#### 9.5.6 Send an e-mail to a contact

1. Tap  > **Contacts**.
2. Tap the contact you want to send an e-mail to.
3. Tap the e-mail address.
4. Select the e-mail account to use.
5. Enter a subject, compose your message, and then tap **Send**.

### 9.5.7 Send a text message to a contact

1. Tap  > **Contacts**.
2. Tap the contact you want to send a text message to, and tap **Menu > Send Text Message**.
3. Compose your message, and tap **Send**.

### 9.5.8 Create a SIM contact

Contacts can be created and stored on a subscriber identity module (SIM.) If you move the SIM to another phone, your SIM contacts are moved as well.

1. Tap  > **Contacts**.
2. Tap **Menu > New SIM Contact**.
3. Enter the name and phone number of the contact and tap **Ok**.

**Note**

SIM contacts appear at the bottom of the contacts list in alphabetical order.

**Tip**

To save an existing contact to your SIM, open the contact and tap **Menu > Save to SIM**.

<b>Inventec</b>	Manual	版 本 : 01
	Mercury	日 期 : 95/12/12

<b>Inventec</b>	Manual	版 本 : 01
	Mercury	日 期 : 95/12/12

## Chapter 10. Photo Contacts



Other than using Contacts, you can also use Photo Contacts to add a new contact. With Photo Contact, you can add a picture to each contact. You can dial contacts by selecting their photograph; when someone calls you, you will easily see his or her photo on the device's screen before you choose to answer.



### 10.1 Transfer photographs to your device

Before you can add a photograph to a contact, you must transfer the photograph from your PC to your device. See "Chapter 6. Transferring files to your device" for different methods to transfer files from a PC to your device.

### 10.2 Add a new photo contact

#### Note

You must first add a picture to a contact in Contacts in order to add him or her to Photo Contacts. (See "9.5.3 Add a picture to a contact" for details.)

1. Tap  > **Programs** >  **Photo Contact**.
2. Tap **Menu** > **Add**.

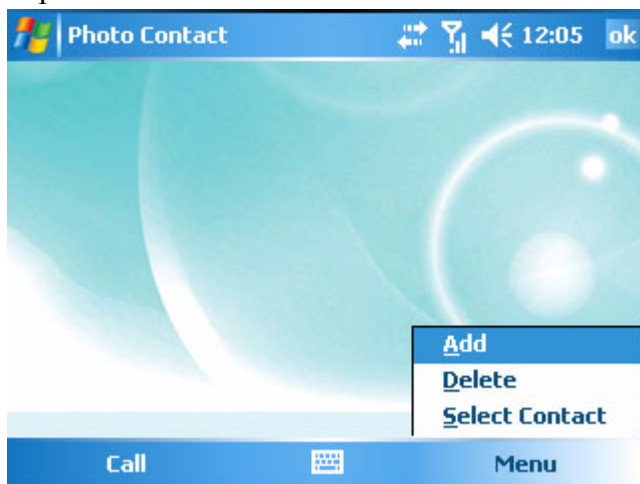

3. Select a contact to add.



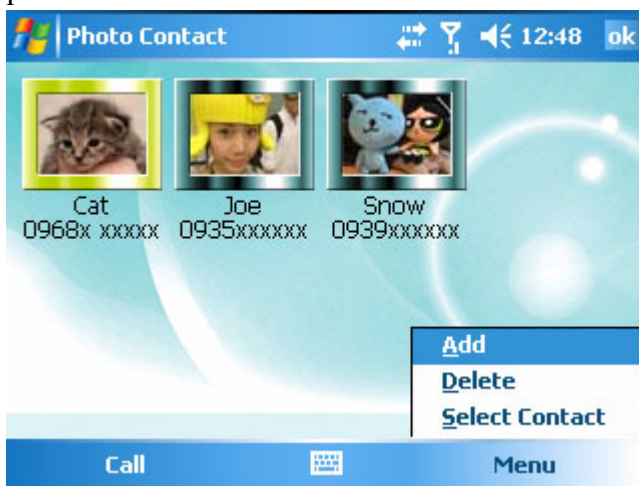

After a contact is added, you should see his or her name and phone number with a photo. You can then select a contact's photo and tap **Call** to make a phone call.





### 10.3 Add a photo to a SIM contact

#### Note

SIM contacts must be saved to Contacts before you can add a photograph to it.

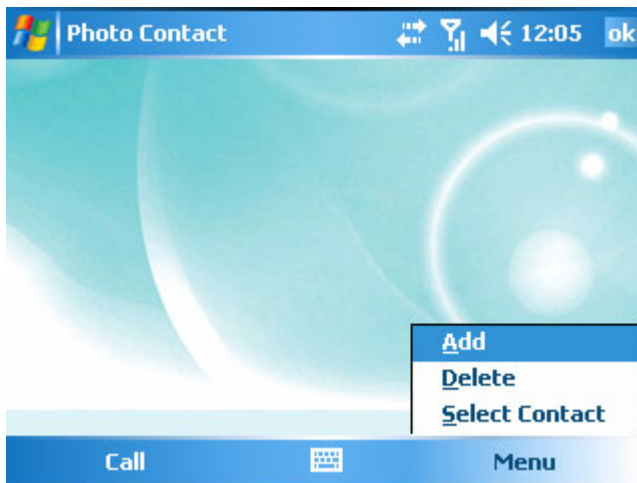
1. Tap  > **Programs** >  **Photo Contact**.
2. Tap **Menu** > **Add**.



3. Select a SIM contact to add. SIM contacts are listed in Contacts with a  icon.



After you select the SIM contact you want to add, his or her information is displayed.



4. Tap **Menu > Save to Contact**.

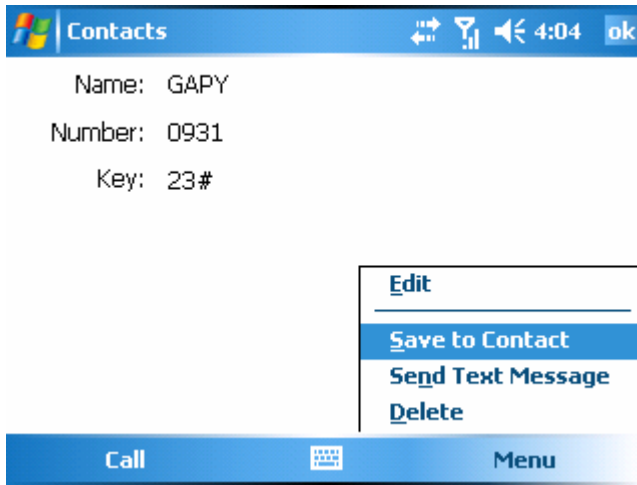

5. Tap **Select a picture** and select a picture for the contact.

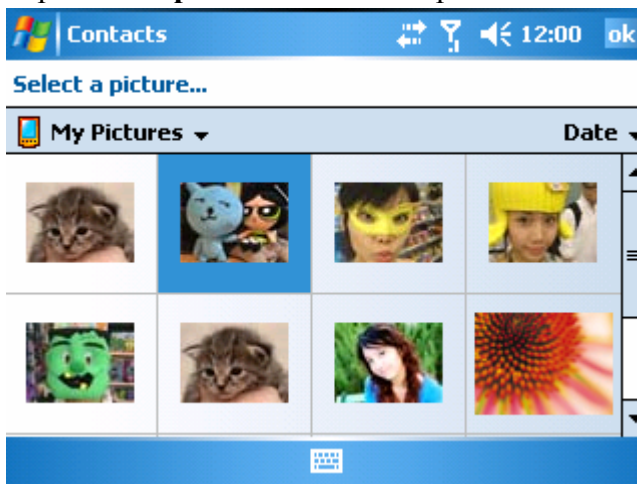

You can also assign a ring tone to the contact. To do so, tap **Ring tone** and select a ring tone for the contact.

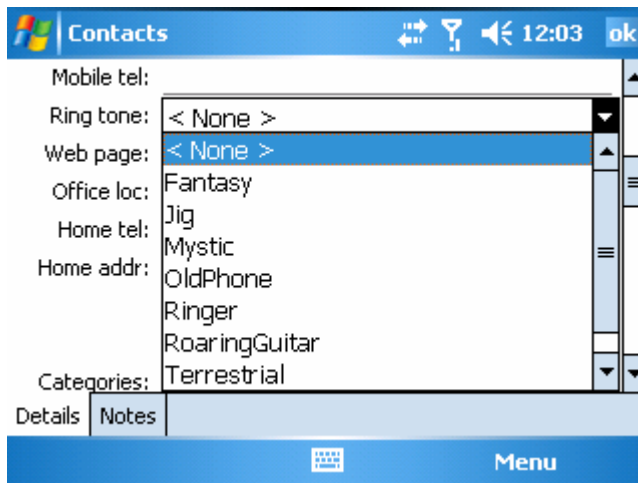

6. Tap **Ok** to save the contact in Contacts.
7. Follow the instruction in the previous section to add the contact to Photo Contacts.

<b>Inventec</b>	Manual	版 本 : 01
	Mercury	日 期 : 95/12/12

<b>Inventec</b>	Manual	版 本 : 01
	Mercury	日 期 : 95/12/12

## Chapter 11. Other Applications

Your device comes with a variety of useful companion applications. This chapter describes the procedure on how to utilize these applications.

### 11.1 Word Mobile

With Word Mobile, you can create and edit Microsoft Word documents and templates, plain text files, and/or rich text format files.

**Note**

Unlike Microsoft Word, you can only have one document open at a time in Word Mobile.

#### 11.1.1 Create a document

1. Do one of the following:
  - Tap  > **Programs** > **Word Mobile**.
  - Tap on the Word Mobile icon in the program shortcut of the Today screen.
2. Tap **New**.
3. Enter text as desired.
4. Tap **Menu** > **File** > **Save as**.
5. Enter a name for the document and tap the **Save** button.

**Note**

You can also tap **Ok** to save a document after you finish entering text. This way, the first few words of the document is being used as the filename.







#### 11.1.2 Word Mobile formatting toolbar

The Formatting toolbar in Word Mobile provides a quick way to apply common formatting such as bold type, bulleted or numbered lists, and paragraph indentation to your text.

- In a Word Mobile document, tap **View** > **Toolbar**.

A check mark appears next to **Toolbar** when the toolbar is visible.



To	Tap
Make the selected text bold	<b>B</b>
Make the selected text italic	<i>I</i>
Underline the selected text	<u>U</u>
Align text to the left	
Center the text	
Align text to the right	
Add or remove a numbered list in the selected text	
Add or remove bullets in the selected text	
Increase the indent of numbered or bulleted list text one tab stop to the right	
Decrease the indent of numbered or bulleted list text one tab stop to the left	

## 11.2 Excel Mobile

With Excel Mobile, you can create and view spreadsheet on you device.

### Note

Unlike Microsoft Excel, you can only have one document open at a time in Excel Word Mobile.

### 11.2.1 Create a new spreadsheet

- Do one of the following:
  - Tap  > **Programs** > **Excel Mobile**.
  - Tap on the Excel Mobile icon in the program shortcut of the Today screen.
- Tap **New**.
- Enter text, numbers, and formulas as desired.

4. Tap **Menu** > **File** > **Save as**.
5. Enter a name for the document and tap the **Save** button.

#### Note







You can also tap **Ok** to save a spreadsheet and Excel Mobile gives it a name automatically.

### 11.2.2 Excel Mobile formatting toolbar

The formatting toolbar in Excel Mobile provides a quick way to apply common formatting such as bold type, bulleted or numbered lists, and paragraph indentation to your text.

- In an Excel Mobile workbook, tap **View** > **Toolbar**.

A check mark appears next to Toolbar when the toolbar is visible.

To	Tap
Create a chart from the selected cells	
Align text to the left	
Center the selected text	
Align text to the right	
Add all contiguous numbers in a column or row	
Add a currency symbol	
Add the default thousands separator	,
Add a decimal point	.00
Increase and decrease the magnification	

### 11.3 PowerPoint Mobile

With PowerPoint Mobile, you can view PowerPoint slides on you device.

**Note**

PowerPoint Mobile only supports slides in .ppt and .pps formats.

### 11.3.1 Start a PowerPoint presentation

1. Do one of the following:
  - Tap  > **Programs** > **PowerPoint Mobile**.
  - Tap on the PowerPoint Mobile icon in the program shortcut of the Today screen.
2. Tap the slide show you want to view in the presentation list.
3. Tap the current slide to advance to the next slide if slides don't advance automatically.
4. Tap **Menu** > **File** > **Save as**.
5. Enter a name for the document and tap **Save**.

### 11.3.2 Stop a PowerPoint presentation

- In a slide show, tap ( ) > End Show.

### 11.3.3 Navigate between slides

- Tap ( ) > **Next** to go to the next slide.
- Tap ( ) > **Previous** to go back to the previous slide.
- To jump to any slide in the slide show, tap ( ) > **Go to Slide** and tap on the slide you want to view.

## 11.4 MSN Messenger

You can send instant messages with MSN Messenger.

**Note**

Your device must be connected to the Internet before you can start using MSN Messenger.

### 11.4.1 Sign in/out MSN Messenger

With MSN Messenger, you can send and receive instant messages from other MSN Messenger users.

**Note**

You must have a valid Microsoft .NET Passport or Hotmail account before you can sign in to MSN Messenger.

Sign in:

1. Tap  > **Programs** > **Pocket MSN**.
2. Tap **MSN Messenger**.
3. Tap **Sign In**, anywhere on the MSN Messenger screen, or **Menu** > **Sign In** to sign in MSN Messenger.
4. Enter your e-mail and password and tap **Sign In**.

Sign out:

- Tap **Menu** > **Sign out**.

#### 11.4.2 Add/Delete a MSN Messenger contact

1. Sign in MSN Messenger.
2. Do any of the following:
  - To add a contact, tap **Menu** > **Add a Contact**, and follow the on-screen instructions.
  - To delete a contact, tap and hold the contact name in the MSN contact list, then tap **Delete Contact**.

#### 11.4.3 Send an instant message

1. Sign in MSN Messenger.
2. Tap the contact's name to whom you want to send a message to.
3. Enter a message and tap Send.

**Tip**

To add a preset message, tap **Menu** > **My Text** and select a preset message.

#### 11.4.4 Change MSN Messenger display name

1. Sign in MSN Messenger.
2. Tap **Menu** > **Options** > **Messenger** tab.

3. Enter a new display name and tap **Ok**.

#### 11.4.5 Block/Unblock a contact

- To block a contact from seeing you on-line, tap and hold the contact's name and select **Block**.
- To unblock a contact, tap and hold the contact's name and select **Unblock**.

#### 11.4.6 Change MSN Messenger settings

1. Sign in MSN Messenger.
2. Tap **Menu > Options**.
3. Select the type of options to change.
4. Tap **Ok**.

<b>Inventec</b>	Manual	版 本 : 01
	Mercury	日 期 : 95/12/12

## **FCC Regulations:**

●This mobile phone complies with part 15 of the FCC Rules. Operation is subject to the following two conditions: (1) This device may not cause harmful interference, and (2) this device must accept any interference received, including interference that may cause undesired operation.

●This mobile phone has been tested and found to comply with the limits for a Class B digital device, pursuant to Part 15 of the FCC Rules. These limits are designed to provide reasonable protection against harmful interference in a residential installation. This equipment generates, uses and can radiated radio frequency energy and, if not installed and used in accordance with the instructions, may cause harmful interference to radio communications. However, there is no guarantee that interference will not occur in a particular installation. If this equipment does cause harmful interference to radio or television reception, which can be determined by turning the equipment off and on, the user is encouraged to try to correct the interference by one or more of the following measures:

- Reorient or relocate the receiving antenna.
- Increase the separation between the equipment and receiver.
- Connect the equipment into an outlet on a circuit different from that to which the receiver is connected.
- Consult the dealer or an experienced radio/TV technician for help.

Changes or modifications not expressly approved by the party responsible for compliance could void the user's authority to operate the equipment.

## ▶ RF Exposure Information (SAR)

This model phone meets the government's requirements for exposure to radio waves. This phone is designed and manufactured not to exceed the emission limits for exposure to radio frequency (RF) energy set by the Federal Communications Commission of the U.S. Government.

The exposure standard for wireless mobile phones employs a unit of measurement known as the Specific Absorption Rate, or SAR. The SAR limit set by the FCC is 1.6W/kg. \*Tests for SAR are conducted using standard operating positions accepted by the FCC with the phone transmitting at its highest certified power level in all tested frequency bands. Although the SAR is determined at the highest certified power level, the actual SAR level of the phone while operating can be well below the maximum value. This is because the phone is designed to operate at multiple power levels so as to use only the power required to reach the network. In general, the closer you are to a wireless base station antenna, the lower the power output.

The highest SAR value for the model phone as reported to the FCC when tested for use at the ear is 0.664 W/kg for GSM850 / 0.971 W/kg for PCS1900 and when worn on the body, as described in this user guide, is 0.424 W/kg for GSM850 / 0.771 W/kg for PCS1900 (Body-worn measurements differ among phone models, depending upon available enhancements and FCC requirements.)

While there may be differences between the SAR levels of various phones and at various positions, they all meet the government requirement.

The FCC has granted an Equipment Authorization for this model phone with all reported SAR levels evaluated as in compliance with the FCC RF exposure guidelines. SAR information on this model phone is on file with the FCC and can be found under the Display Grant section of <http://www.fcc.gov/oet/fccid> after searching on FCC ID: DGIBC0037AAA000.

For body worn operation, this phone has been tested and meets the FCC RF exposure guidelines for use with an accessory that contains no metal and the positions the handset a minimum of 1.5 cm from the body. Use of other enhancements may not ensure compliance with FCC RF exposure guidelines. If you do not use a body-worn accessory and are not holding the phone at the ear, position the handset a minimum of 1.5 cm from your body when the phone is switched on.