



IRIDIUM

9522B L-Band Transceiver Product Information Guide



Iridium Satellite LLC
6701 Democracy Blvd., Suite 500
Bethesda, MD 20817 USA
www.iridium.com

Toll Free: +1.866.947.4348 [US Only]
International +1.480.752.5155
email: info@iridium.com

Contents

Revision History	3
1.0 Product Overview	4
2.0 Standards Compliance	5
2.1 FCC Compliance.....	5
2.2 CE Compliance	5
3.0 Physical Specifications	6
3.1 Environmental.....	6
3.2 Dimensions	6
3.3 Interface Connectors	8
3.3.1 Multi-Interface Connector	9
3.3.2 Antenna Connector	10
3.3.3 GPS Feed-thru Connector	10
3.3.4 SIM Chip Reader	10
3.4 Mounting.....	10
3.5 Mounting in Harsh Environments.....	11
4.0 Electrical Interfaces	12
4.1 DC Power Interface.....	12
4.1.1 DC Power Interface Signal Descriptions	12
4.1.2 DC Power Input Specifications.....	12
4.2 Control/Digital Audio (DPL bus) Interface	12
4.2.1 Control/Digital Audio Interface Signal Descriptions	12
4.3 RS232 Data Interface.....	13
4.3.1 RS232 Data Signal Descriptions.....	13
4.3.2 Autobaud.....	13
4.4 Analog Audio Interface.....	13
4.4.1 Analog Audio Interface Signal Descriptions	13
4.5 SIM Interface	13
4.6 RF Interface	14
4.6.1 RF Interface Specifications	14
4.6.2 GPS Feed Thru Specifications	14
4.6.3 Radio Characteristics	14
5.0 Instructions for the safe Installation and use of the 9522B LBT	15
5.1 Instructions for the Integrator	15
5.2 Instructions from the integrator to the user.....	15
6.0 Modem Commands and Configuration.....	15
7.0 Installation of the 9522B in place of a 9522A	16
7.1 Physical characteristics	16
7.2 Power Supply	17

Revision History

Revision	Date	Comment
V0.1		First revision based on 9522A product information guide
V0.2	17 April 2008	Updated mechanical drawings, mass and power.
V0.3	22 May 2008	Updated Header and DC Power Input Specification
V0.4	16 Jun 2008	Added 9522A adapter information. Updated DC Power Input Specification
V1.0	30 June 2008	Initial Release

Export Compliance Information

This product is controlled by the export laws and regulations of the United States of America. The U.S. Government may restrict the export or re-export of this product to certain individuals and/or destinations. For further information, contact the U.S. Department of Commerce, Bureau of Industry and Security or visit www.bis.doc.gov.

1.0 Product Overview

The 9522B L-Band Transceiver (LBT) is designed to be integrated into a specific application with other hardware and software to produce a solution designed for a specific application or vertical market. Some examples of these solutions include a maritime voice telephony terminal or a vehicle tracking solution.

The LBT functionally supports all of Iridium's voice and data services. Applications can be built to use one or multiple services using the voice and data interfaces. The 9522B is a functional replacement to the 9522A LBT, although the mechanical design and the electrical connectors differ. Connection adaptors are available to enable the 9522B to be used in place of the 9522A.

A pass thru connector is provided to allow a GPS receiver to share the same antenna as the 9522B LBT.

The 9522B is regulatory approved for FCC, Canada, and CE assuming an antenna with a gain of ~3dBi. This allows the LBT to be integrated into a variety of subscriber products, or retrofitted into existing LBT-based products. These products, when integrated together will require regulatory testing to be conducted by the integrator.

The LBT is essentially provided as a 'black box' with all interfaces provided via a 26-way 0.1" pitch connector. The product provides the core transceiver module and SIM card reader. All other functions and hardware such as keypad, display, power supply, antenna etc. must be provided by the solution developer. The connector provides the following interfaces and connections:

- Analog Audio
- Control / Digital Audio
- RS232
- Power Input
- On / Off

2.0 Standards Compliance

The 9522B is designed to comply with the standards for Radio Emissions Compliance, Electromagnetic Compatibility, and AC Safety in the United States, European Union and Canada.

2.1 *FCC Compliance*

The 9522B is certified under 47 CFR Part 25 as FCC ID: Q639522B. It also complies with Part 15 of the FCC Regulations. Operation is subject to the condition that this device does not cause harmful interference. Any changes or modifications, including the use of a non-standard antenna, not expressly approved by the party responsible for compliance could void the user's authority to operate the equipment.

IMPORTANT: To comply with FCC RF exposure requirements, a minimum separation of 20 cm is required between the antenna and all persons.

2.2 *CE Compliance*

This product, when marked with the CE symbol, complies with the European Community Council Directive for R&TTE, 99/5/EC, provided that the integrator/user adheres to the instructions detailed in this LBT Interface Specification. This product is in compliance with applicable ETSI standards. Compliance with the requirements of ETSI EN 301 489 requires the use of a shielded digital data interface cable.

3.0 Physical Specifications

The 9522B is depicted in Figure 1 below.

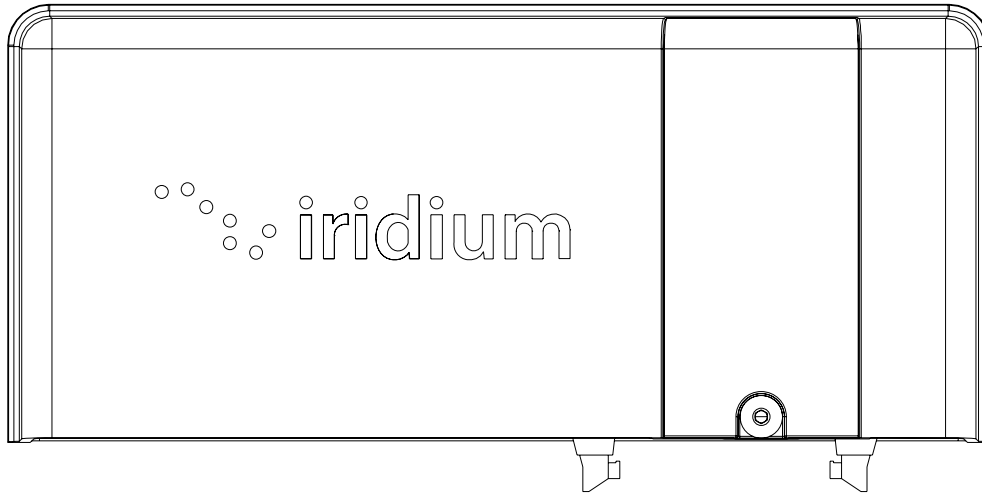

Figure 1: Top View of 9522B

3.1 Environmental

The environmental specifications of the 9522B LBT are summarized in Table 1 below.

Table 1: Environmental Specifications

Parameter	Value
Operating Temperature Range	-30°C to + 70°C
Operating Humidity Range	25 to 75% RH
Storage Temperature Range	-40°C to + 85°C
Storage Humidity Range	≤ 93% RH

3.2 Dimensions

The overall dimensions of the 9522B LBT and its weight are summarized in Table 2 below. Dimensioned views of the 9522B LBT are shown in Figures 2-5 which follow. All dimensions are in mm unless otherwise stated.

Table 2: Mechanical Dimensions

Parameter	Value
Length	162 mm (6.38")
Width	81 mm (3.16")
Depth	28 mm (1.10")
Weight (approximate)	420 g

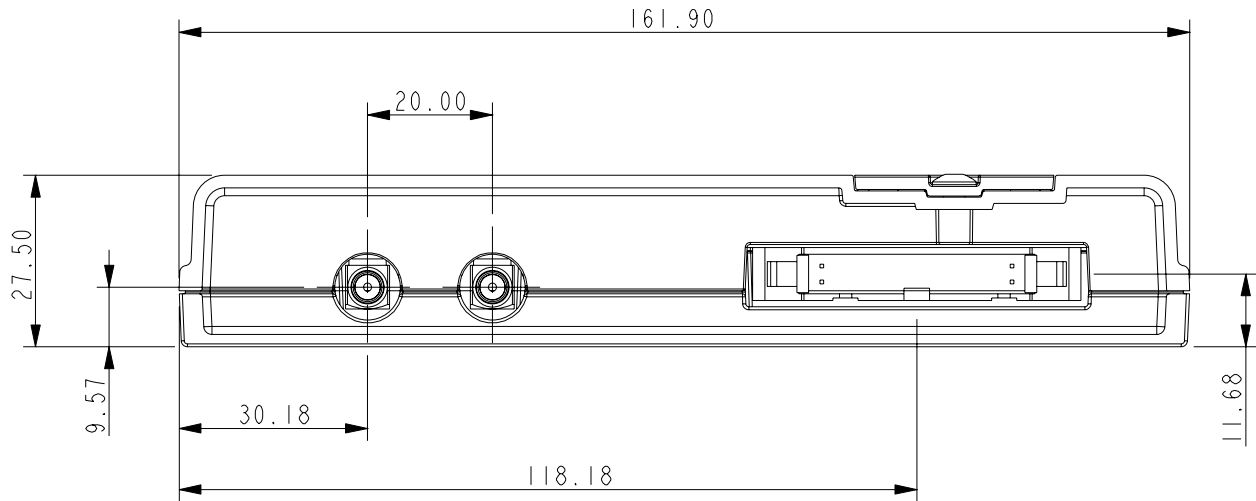

Figure 2: Bottom (connector) View

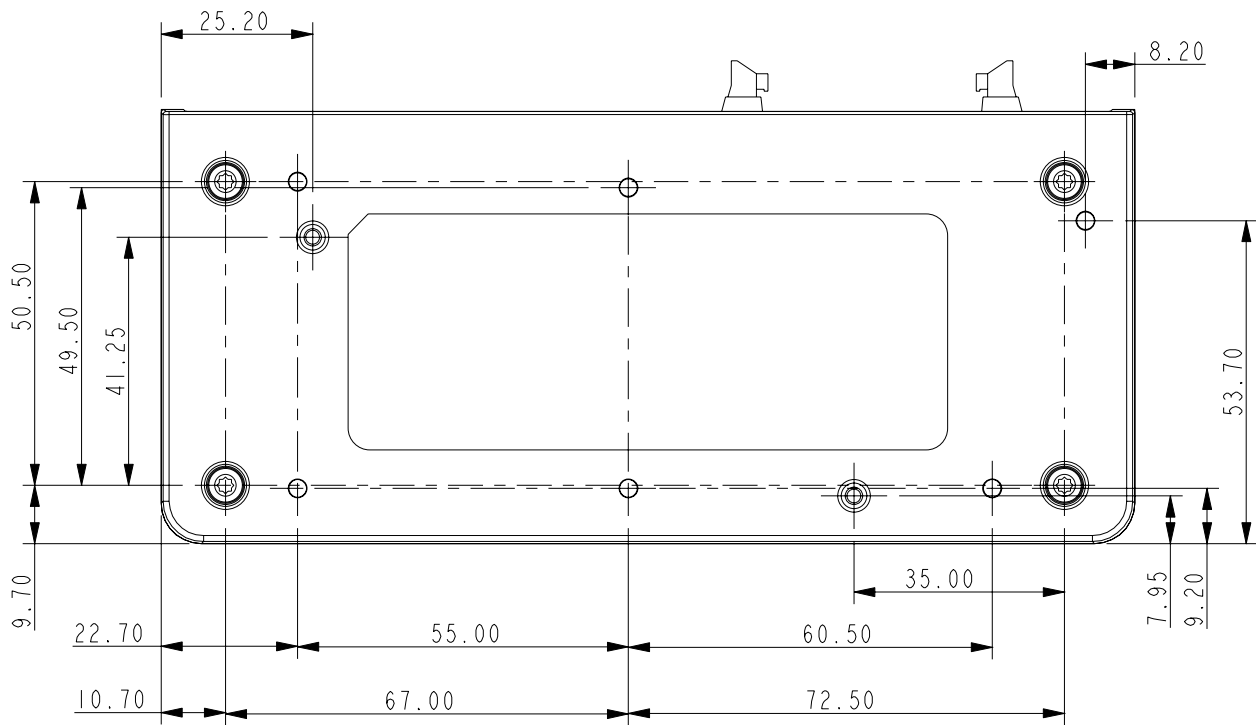

Figure 3: Back (mounting) View

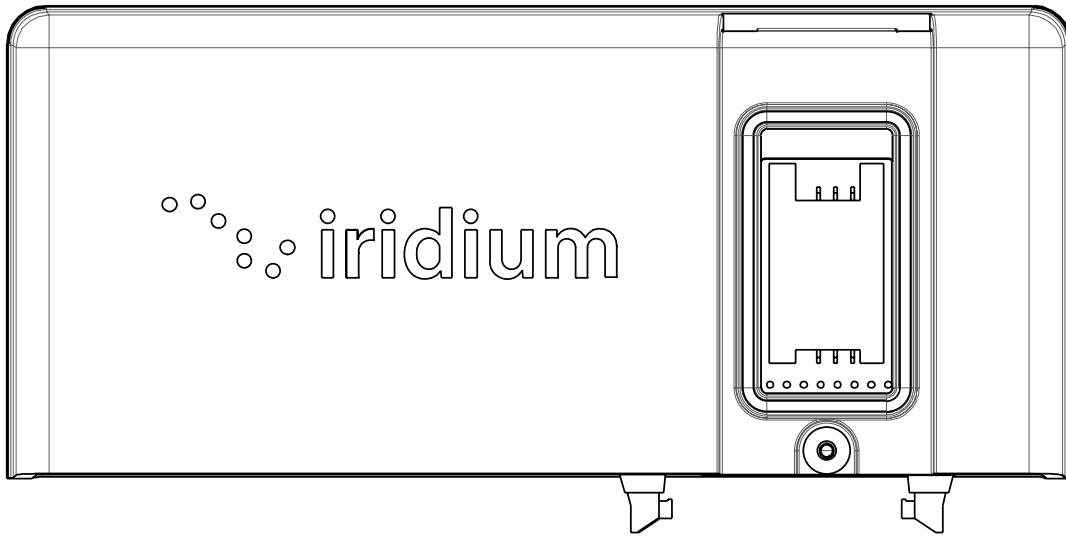

Figure 4: Front (SIM access) View

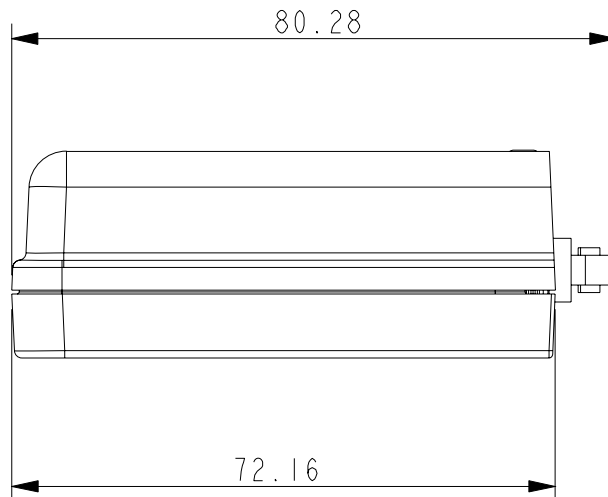

Figure 5: End View

3.3 Interface Connectors

The 9522B LBT incorporates four interface connectors:

- Multi-Interface Connector (located at the right-hand end of the bottom of the 9522B LBT)
- Antenna Connector (located at the left-hand end of the bottom of the 9522B LBT)
- GPS pass-thru Connector (located in the middle of the bottom of the 9522B LBT)
- Subscriber Identity Module (SIM) Chip Connector (located beneath a cover plate on the front of the 9522B LBT)

3.3.1 Multi-Interface Connector

The multi-interface connector is a standard 26-pin 0.1” pitch short latch IDC header with pins in two rows of 13. Connection to this is made using a 26-way IDC without strain relief (such as AVX/Kyocera 00 8290 026 000 0X 1 or Harting 09 18 526 7803). To support legacy applications, a cable is available that converts its pin-out to a DB25 connector with the same pin-out as the 9522A. The connector includes four interfaces:

- DC Power
- Control/Digital Audio (DPL bus)
- RS232 Data
- Analog Audio

The pin out information for this connector is given in Table 3 below. The pin out from the DB25 adapter is given in Table 4 below.

Table 3: 26-way connector pin-out

Contact	Signal	Description
1	EXT_ON_OFF	External connection for On / Off key input to LBT
2	0V	Signal ground, 0V signal reference and return
3	EXT_11HZ	90ms “frame sync” signal (used in testing)
4	MIC_AUD	Microphone audio input to LBT
5	EXT_GND	Power Ground input to LBT
6	EXT_PWR	Power input to LBT
7	EXT_PWR	Power input to LBT
8	EXT_GND	Power Ground input to LBT
9	SPKR_AUD	Speaker audio output from LBT
10	DPL_TX	Digital Peripheral Link (UART) data output from LBT
11	DA_TX	PCM digital audio output from LBT
12	DF_DTR	Data / Fax Data Terminal Ready input to LBT
13	DF_RI	Data / Fax Ring Indication output from LBT
14	DPL_RX	Digital Peripheral Link (UART) data input to LBT
15	DF_RTS	Data / Fax Request to Send input to LBT
16	DF_DSR	Data / Fax Data Set Ready output from LBT
17	DF_S_TX	Data / Fax (UART) data input to LBT
18	DF_CTS	Data / Fax Clear to Send output from LBT
19	DF_DCD	Data / Fax Data Carrier Detect output from LBT
20	0V	Signal ground, 0V signal reference and return
21	DA_FS	PCM digital audio frame sync output from LBT
22	DA_RX	PCM digital audio input to LBT
23	DA_CLK	PCM digital 2.048MHz audio clock output from LBT
24	0V	Signal ground, 0V signal reference and return
25	DF_S_RX	Data / Fax data (UART) output from LBT
26	NETWORK_AVAILABLE	Network available output from LBT

Table 4: 25-way D connector pin-out

Contact	Signal	Description
1	EXT_ON_OFF	External connection for On / Off key input to LBT
2	EXT_11HZ	90ms "frame sync" signal (used in testing)
3	EXT_GND	Power Ground input to LBT
4	EXT_PWR	Power input to LBT
5	SPKR_AUD	Speaker audio output from LBT
6	DA_TX	PCM digital audio output from LBT
7	DF_RI	Data / Fax Ring Indication output from LBT
8	DF_RTS	Data / Fax Request to Send input to LBT
9	DF_S_TX	Data / Fax (UART) data input to LBT
10	DF_DCD	Data / Fax Data Carrier Detect output from LBT
11	DA_FS	PCM digital audio frame sync output from LBT
12	DA_CLK	PCM digital 2.048MHz audio clock output from LBT
13	DF_S_RX	Data / Fax data (UART) output from LBT
14	0V	Signal ground, 0V signal reference and return
15	MIC_AUD	Microphone audio input to LBT
16	EXT_PWR	Power input to LBT
17	EXT_GND	Power Ground input to LBT
18	DPL_TX	Digital Peripheral Link (UART) data output from LBT
19	DF_DTR	Data / Fax Data Terminal Ready input to LBT
20	DPL_RX	Digital Peripheral Link (UART) data input to LBT
21	DF_DSR	Data / Fax Data Set Ready output from LBT
22	DF_CTS	Data / Fax Clear to Send output from LBT
23	0V	Signal ground, 0V signal reference and return
24	DA_RX	PCM digital audio input to LBT
25	0V	Signal ground, 0V signal reference and return

3.3.2 Antenna Connector

The 9522B LBT provides a single 50 Ω, SMA type antenna connector both transmit and receive. An adaptor is available to convert this connector to TNC to enable the 9522B to be used as a replacement for a 9522A.

3.3.3 GPS Feed-thru Connector

To enable a GPS receiver to share the antenna, the 9522B LBT passes the received signal through to a 50 Ω, SMA type connector. It is intended that this be connected to a GPS receiver. Note that this signal will not be usable during a call.

3.3.4 SIM Chip Reader

An integrated SIM chip reader is provided on the 9522B LBT. This connector allows installation of the chip form of the SIM beneath a cover plate on the 9522B LBT housing.

3.4 Mounting

The 9522B LBT incorporates (6) mounting holes on its bottom surface that can aid in its mounting. See Figure 3 for locations of these features. It is recommended that a thread-forming screw be used to mount the 9522B LBT via these features. Particularly, a Textron Camcar® Taptite® II Thread-Rolling Fastener of M3.5x0.6 thread type is recommended. This fastener has a 15IP Torx Plus® pan head and is available in lengths of 6, 8, 12, 16, and 20 mm as part number 3BE-P802-00, 3BE-P803-00, 3BE-P8185-00, 3BE-P804-00, 3BEP8186-00, and 3BE-P8187-00 respectively. Length should be chosen to ensure that penetration into the 9522B LBT housing does not exceed 11 mm. If a 6-32 thread type is desired, a

Textron Camcar® Taptite® II Thread-Rolling Fastener with a 15IP Torx Plus® pan head is available in lengths of 1/4, 5/16, 3/8, 1/2, 5/8, 3/4, and 1 inch as part number 3BE-P814-00, 3BE-P8123-00, 3BE-P815-00, 3BE-P816-00, 3BE-P8124-00, 3BE-P817-00, and 3BE-P818-00 respectively. A 10IP Torx Plus® flat head version is also available in a single length of 1/2 inch as part number 3BE-P801-00. Another 6-32 thread type option is to insert a helical coil insert with a 6-32 internal thread into these features thus accommodating 6-32 threaded fasteners as mounting hardware for the 9522B LBT. National Aerospace Standard NASM122238 serves as a technical reference for the recommended helical coil insert.

3.5 *Mounting in Harsh Environments*

If the 9522B LBT is to be used in a harsh environment with exposure to high humidity, water or dust, the LBT must be installed in the correct orientation, with all connectors facing downwards.

4.0 Electrical Interfaces

The subsections to follow contain interface information for the electrical interfaces of the 9522B LBT.

4.1 DC Power Interface

4.1.1 DC Power Interface Signal Descriptions

The DC power interface is comprised of the DC power inputs and a control signal as summarized in Table 5 below. The EXT_PWR and GND inputs are used to supply DC power to the 9522B LBT. The EXT_ON_OFF control input is pulled to a GND level to toggle the 9522B LBT on and off. Note that both pairs of pins should be connected for EXT PWR and EXT GND.

Table 5: Control/Audio Interface Signal Descriptions

Signal Name	Signal Description
EXT_PWR (pin 6 and 7)	External power input
EXT_GND (pin 5 and 8)	External power GND input
EXT_ON_OFF (pin 1)	Power on/off control input

4.1.2 DC Power Input Specifications

The DC power requirements for the 9522B LBT are summarized in Table 5 below. Note that these requirements apply to DC power measured at the 9522B LBT multi-interface connector input.

Table 5: DC Power Input Specifications

Parameter	Value
Main Input Voltage Range	+4.0 VDC to +32 VDC
Main Input Voltage - Nominal	5VDC, 12VDC or 24VDC
Main Input Voltage – Ripple	40 mV peak to peak
Consumption at +5 VDC	
Input Standby Current (average)	250mA
Max current during call	2.5A
Typical current during call (see note)	800mA
Power Average – Voice/Data Call (see note)	4W

Note: The average power consumption depends on the view of the satellite constellation from the antenna.

4.2 Control/Digital Audio (DPL bus) Interface

4.2.1 Control/Digital Audio Interface Signal Descriptions

The control/digital audio interface enables peripherals such as handsets and SIM card readers to be interfaced to the 9522B LBT. The interface utilizes an Iridium Proprietary communication bus not detailed in this fact sheet. Details can be made available after appropriate Non-Disclosure and/or License Agreements are executed.

4.3 RS232 Data Interface

4.3.1 RS232 Data Signal Descriptions

The RS232 data interface is comprised of eight standard RS232 data, control, and status signals plus a ground level signal reference. This interface allows a connected Data Terminal Equipment (DTE) to utilize the 9522B LBT's modem functionality via AT command control. A 3-wire RS232 Data minimal interface may also be implemented however the 9 wire interface offers better control and is the recommended implementation.

4.3.2 Autobaud

Autobaud is enabled by default. Autobaud will occur on the following characters 'a', 'A', or CR (carriage return). Autobaud will also occur on the escape sequence character, provided this is an odd number character. Normally this is set to '+' in register S2. See the AT Command Reference for details.

4.4 Analog Audio Interface

4.4.1 Analog Audio Interface Signal Descriptions

The analog audio interface is comprised of the analog audio input and output signals referenced to the 0V signal ground as summarized in Table 6 below.

Table 6: Analog Audio Interface Signal Descriptions

Signal Name	Signal Description
MIC_AUD (pin 4)	Analogue audio input to LBT
SPKR_AUD (pin 9)	Analogue audio output from LBT
0V (pins 2, 20, 24)	Signal ground

4.5 SIM Interface

An integrated SIM chip reader is provided on the 9522B LBT. An external SIM card reader may also be interfaced as a peripheral to the 9522B LBT via the DPL bus (control/audio interface). A SIM card in the external reader will take precedence over the SIM chip in the integrated connector when both are present.

4.6 RF Interface

4.6.1 RF Interface Specifications

The RF interface requirements for the 9522B LBT are summarized in Table 7 below.

Table 7: General RF Parameters

Parameter	Value
Frequency Range	1616 MHz to 1626.5 MHz
Duplexing Method	TDD (Time Domain Duplex)
Oscillator Stability	± 1.5 ppm
Input/Output Impedance	50 Ω
Multiplexing Method	TDMA/FDMA

4.6.2 GPS Feed Thru Specifications

The RF interface of the GPS feed thru connector are summarized in below.

Table 8: General RF Parameters

Parameter	Value
Frequency Range	1575 MHz
Input/Output Impedance	50 Ω
Insertion Loss	≤ 3 dB
Noise Figure	≤ 7 dB

4.6.3 Radio Characteristics

The tables within this section contain radio characteristics of the 9522B LBT.

Table 9: In-Band Characteristics

Parameter	Value
Average Power during a transmit slot (max)	7 W
Average Power during a frame (typical)	0.6 W
Receiver Sensitivity at 50 Ω (typical)	-118.5 dBm
Receiver Spurious Rejection at offsets > 1 MHz (typical)	60 dB

Table 10: Link Margin

Configuration	Cable Loss	Link Margin
9522B LBT with accessory antennas (Note 1)	2 dB (Note 2)	13.1 dB (Note 3)

Note 1: Other antenna options are available

Note 2: Cable losses should be minimized

Note 3: Link Margin given for free space

5.0 Instructions for the safe Installation and use of the 9522B LBT

The 9522B LBT is intended for integration into a finished product. The integrator of the 9522B LBT is required to connect a power supply, antenna, and user interface to the 9522B LBT. To ensure that the 9522B LBT is correctly installed the following general instructions (sub-section 5.1) are provided for the installer.

The integrator will be required to supply the end user of the integrated product, incorporating the 9522B LBT, with operating instructions and any other information relating to the maintenance and safety of the equipment (sub-section 5.2).

5.1 *Instructions for the Integrator*

- The 9522B LBT must be installed by an appropriately qualified installer and mounted securely as described in section 3.4 of this document.
- The power supply used to power the 9522B LBT must be checked to ensure it meets the requirements of sub-section 4.1.2 of this document.
- Electrical connections to the 9522B LBT multi-interface connector shall be as designated in Table 3 of sub-section 3.3.1 of this document.
- The current and voltage rating of the multi-interface connector cable shall meet the requirements of the LBT DC power input.
- The electrical characteristics of the multi-interface connector cable shall not degrade the 9522B LBT digital communications and analog audio signals.
- The multi-interface connector cable will provide adequate screening from external electromagnetic interference.
- The 9522B LBT shall not be located in close proximity to sources of extreme temperature which will cause it to be operated outside of its temperature specification.
- The 9522B LBT shall not be operated without an appropriate antenna connected to its Antenna connector via a suitable 50 Ohm coaxial cable. This antenna shall be sited at least 20cm away from any person.

5.2 *Instructions from the integrator to the user*

To comply with the requirements of sub-clause 1.7.2 (Safety instructions) of the European Information technology equipment safety standard EN60950-1:2002 the integrator must ensure that:

'Sufficient information shall be provided to the USER concerning any condition necessary to ensure that, when used as prescribed by the manufacturer, the equipment is unlikely to present a hazard within the meaning of this standard. If it is necessary to take special precautions to avoid the introduction of hazards when operating, installing, servicing, transporting or storing equipment, the necessary instructions shall be made available.'

As part of these instructions the installer should inform the user that they should not service the 9522B LBT.

6.0 Modem Commands and Configuration

The 9522B is configured through the use of AT commands. A full listing of the supported AT commands can be found in the AT Command Reference document.

7.0 Installation of the 9522B in place of a 9522A

The 9522B is designed to replace the 9522A with the assistance of an optional adapter plate and cables. An adapter plate is mounted onto the 9522B and provides mounting points similar to those of the 9522A. The antenna cable adapter provides a cable-mounted TNC connector similar to the 9522A. The Multi-interface adapter cable provides a mechanical and electrical interface similar to the 9522A (although please see the note in section 7.2 below)

7.1 Physical characteristics

The physical design of the 9522B adapter is given in Figures 7-10 which follow. All dimensions are in mm unless otherwise stated. The TNC adapter is cable-mounted to allow flexibility in the routing of the antenna cable.

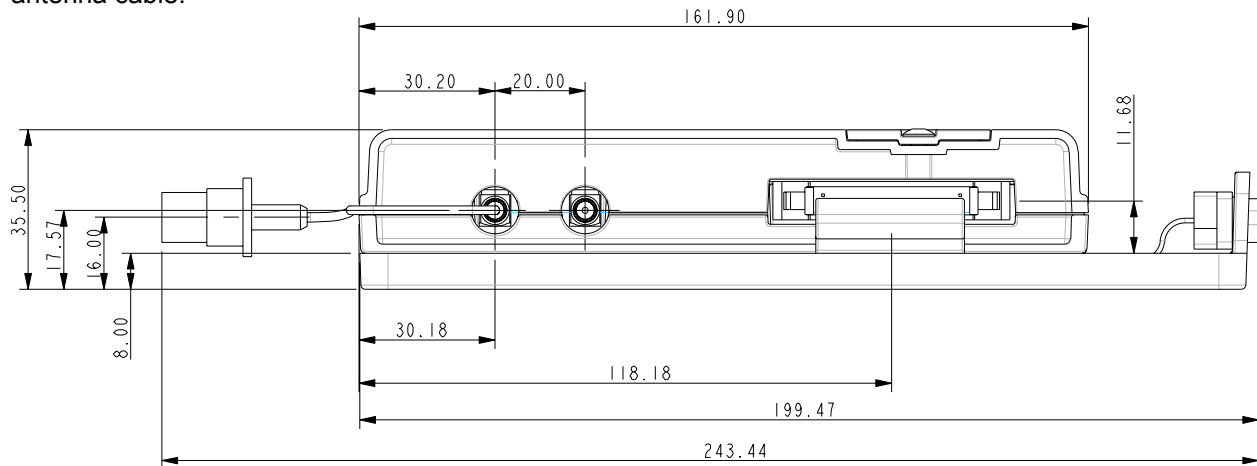

Figure 6: Bottom (connector) View

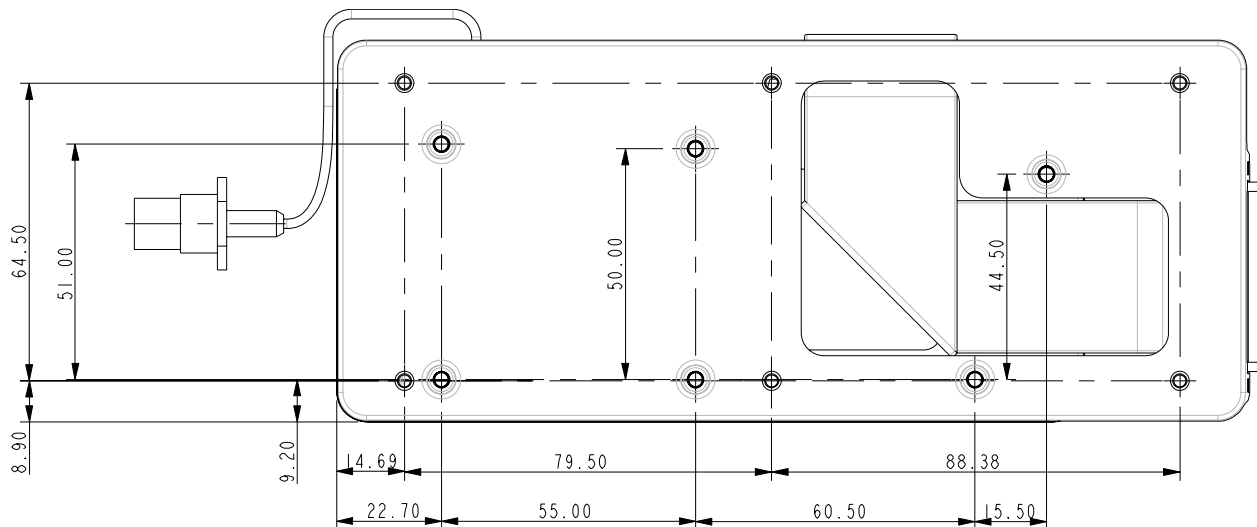

Figure 7: Back (mounting) View

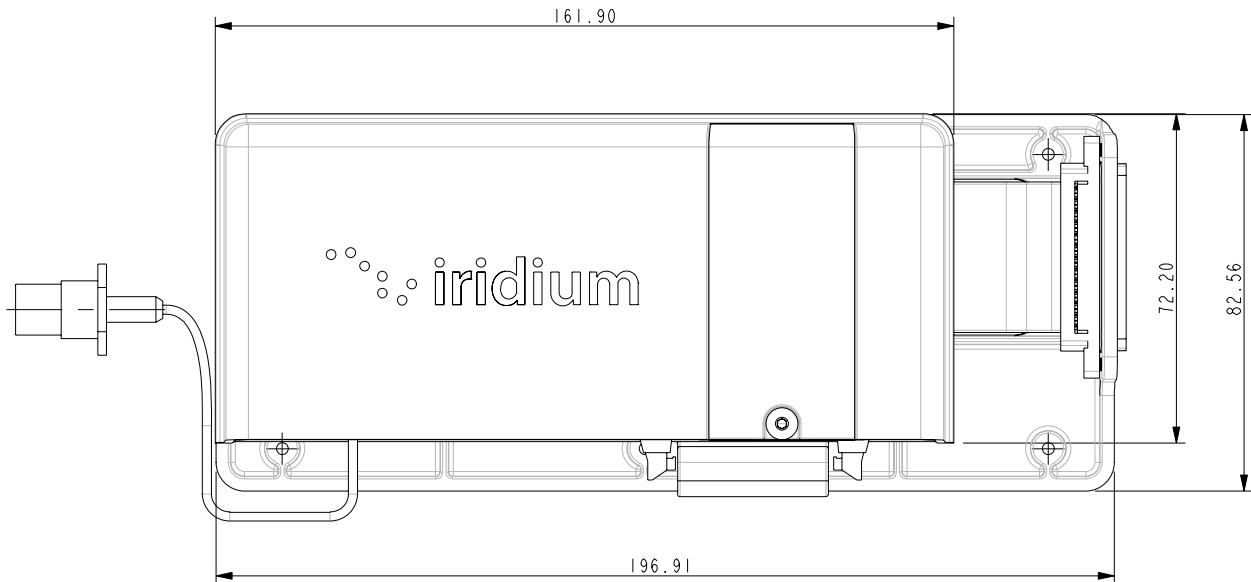

Figure 8: Front (SIM access) View

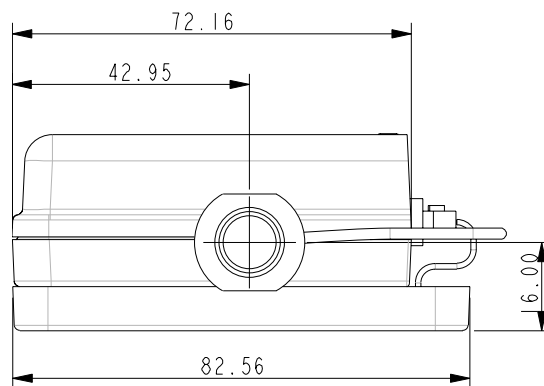

Figure 9: End View

7.2 Power Supply

With the adapter cables in use, the requirements for the signals to and from the 9522B are as given in section 3.3. Note that it is important to ensure that the power supply voltage measured at the 9522B multi-way connector does not fall below 4.0v. In order to allow for the voltage drop due to the resistance of the adapter cable and connectors, it is recommended that the voltage at the 25-way D-type connector should be 4.2v minimum. If it is possible to change the supply voltage in the application, it is recommended that 5v, 12v or 24v is used, as the effect of voltage drop will be reduced and the 9522B operates more efficiently.