



Iridium Core 9523/9523N Product Developer's Guide



Iridium Communications, Inc.
Proprietary & Confidential Information

LEGAL DISCLAIMER AND CONDITIONS OF USE

This document contains information for the Iridium Core 9523/9523N ("Product") and is provided "as is." The purpose of providing such information is to enable Value Added Resellers and Value Added Manufacturers (collectively, "Product Developer(s)") to understand the Product and how to integrate it into a wireless solution. Reasonable effort has been made to make the information in this document reliable and consistent with specifications, test measurements and other information. However, Iridium Communications Inc. and its affiliated companies, directors, officers, employees, agents, trustees or consultants ("Iridium") assume no responsibility for any typographical, technical, content or other inaccuracies in this document. Iridium reserves the right in its sole discretion and without notice to you to change Product specifications and materials and/or revise this document or withdraw it at any time. This document is provided in conjunction with the purchase of the Product and is therefore subject to the Product Sales Terms and Conditions set forth at <http://www.Iridium.com/support/library/LegalNotices.aspx>. The Product Developer assumes any and all risk of using the Product specifications and any other information provided.

Your use of this document is governed by your Partner Agreement with Iridium. Please review your Partner Agreement and the Iridium Product Sales Terms and Conditions that govern your relationship with Iridium. This document is strictly Proprietary and Confidential to Iridium. Consistent with your Partner Agreement with Iridium, you may not this document (or any portion thereof) to others without express written permission from Iridium. Any violation of your Agreement's Proprietary and Confidentiality obligations shall result in remedies to the fullest extent available to Iridium at law or in equity.

IRIDIUM MAKES NO REPRESENTATIONS, GUARANTEES, CONDITIONS OR WARRANTIES, EITHER EXPRESS OR IMPLIED, INCLUDING WITHOUT LIMITATION, ANY IMPLIED REPRESENTATIONS, GUARANTEES, CONDITIONS OR WARRANTIES OF MERCHANTABILITY AND FITNESS FOR A PARTICULAR PURPOSE, NON-INFRINGEMENT, SATISFACTORY QUALITY, NON-INTERFERENCE, ACCURACY OF INFORMATIONAL CONTENT, OR ARISING FROM A COURSE OF DEALING, LAW, USAGE, OR TRADE PRACTICE, USE, OR RELATED TO THE PERFORMANCE OR NONPERFORMANCE OF ANY PRODUCTS AND/OR SERVICES ACCESSORIES, FACILITIES OR SATELLITE SERVICES OR INFORMATION EXCEPT AS EXPRESSLY STATED IN THIS DOCUMENT AND/OR THE PRODUCT AND/OR SATELLITE SERVICE DOCUMENTATION. ANY OTHER STANDARDS OF PERFORMANCE, GUARANTEES, CONDITIONS AND WARRANTIES ARE HEREBY EXPRESSLY EXCLUDED AND DISCLAIMED TO THE FULLEST EXTENT PERMITTED BY LAW. THIS DISCLAIMER AND EXCLUSION SHALL APPLY EVEN IF THE EXPRESS LIMITED WARRANTY CONTAINED IN SUCH DOCUMENTATION FAILS OF ITS ESSENTIAL PURPOSE.

IN NO EVENT SHALL IRIDIUM BE LIABLE, REGARDLESS OF LEGAL THEORY, INCLUDING WITHOUT LIMITATION CONTRACT, EXPRESS OR IMPLIED WARRANTY, STRICT LIABILITY, GROSS NEGLIGENCE OR NEGLIGENCE, FOR ANY DAMAGES IN EXCESS OF THE PURCHASE PRICE OF THIS DOCUMENT, IF ANY. NOR SHALL IRIDIUM BE LIABLE FOR ANY DIRECT, INDIRECT, INCIDENTAL, SPECIAL OR CONSEQUENTIAL DAMAGES OF ANY KIND, OR LOSS OF REVENUE OR PROFITS, LOSS OF BUSINESS, LOSS OF PRIVACY, LOSS OF USE, LOSS OF TIME OR INCONVENIENCE, LOSS OF INFORMATION OR DATA, SOFTWARE OR APPLICATIONS OR OTHER FINANCIAL LOSS CAUSED BY THE PRODUCT/SERVICE (INCLUDING HARDWARE, SOFTWARE AND/OR FIRMWARE) AND/OR THE IRIDIUM SATELLITE SERVICES, OR ARISING OUT OF OR IN CONNECTION WITH THE ABILITY OR INABILITY TO USE THE PRODUCT/SERVICE (INCLUDING HARDWARE, SOFTWARE AND/OR FIRMWARE) AND/OR THE IRIDIUM SATELLITE SERVICES TO THE FULLEST EXTENT THESE DAMAGES MAY BE DISCLAIMED BY LAW AND WHETHER ADVISED OF THE POSSIBILITIES OF SUCH DAMAGES. IRIDIUM IS NOT LIABLE FOR ANY CLAIM MADE BY A THIRD PARTY OR MADE BY YOU FOR A THIRD PARTY.

Your use of the information contained in this Guide is restricted to the development activity authorized under the agreement(s) between you and Iridium, and is otherwise subject to all

applicable terms and conditions of such agreement(s), including without limitation software license, warranty, conditions of use and confidentiality provisions.

Export Compliance Information

This Product is controlled by the export laws and regulations of the United States of America. The U.S. Government may restrict the export or re-export of this Product to certain individuals and/or destinations. Diversion contrary to U.S. law is prohibited. For further information, contact the U.S. Department of Commerce, Bureau of Industry and Security or visit www.bis.doc.gov.

Revision History

Revision	Date	Comment
1.0	Nov 11, 2015	First Draft.
2.0	May 9, 2011	Second Draft Following Internal Review
2.3	Jul 26, 2011	Revision sent with Alpha prototype Developer's Kit
2.5	Sep 12, 2011	Revision sent with Beta prototype Developer's Kit
2.6	Oct 11, 2011	- Added FCC and IC warning statements (sections 1.3 and 1.4) - Removed reference to mounting screws in section 2.1 "Dimensions and Layout" - Clarified screw/hole specifications in section 2.2 "Field Application Board Mounting" - Unified formatting of examples and removed references to AT*Rn in section 8 "Informative Examples"
2.7	Oct 17, 2011	- Replaced reference to AT*F with AT*P0 in section 3.2.3 "Power On/Off Control" - Added note on digital I/O ESD protection in section 3.1.2 "User Connector Pin Allocation"
3.0	Oct 21, 2011	First published revision
3.1	Oct 27, 2011	Added note on non-portable regulatory certification to section 1.2
3.2	Feb 23, 2012	Significantly reduced sections "Data/Fax Port" and "AT Interface" and added references to the ISU AT Command Reference. Removed sections "S-Register Definitions", "Summary of Result Codes", "Informative Examples", and "Supported AT Commands" as this information is contained in the ISU AT Command Reference.
7.0	Aug 20, 2012	- Updated section "Legal Disclaimer and Conditions of Use". - Removed description of PCB digital audio ports as "15 bits" in section 3.3 "PCM Digital Audio" since the ports use 16-bit PCM samples.
7.1	Jul 29, 2014	- Changed all references to the product to "Iridium Core 9523" - Corrected section 4 sub-section numbering - Revised introductory paragraph of section 2.3.2
7.2 DRAFT2	Nov 17, 2015	Updated to include 9523N. For internal review. Incorporated comments from Mike Senzig.
7.2 DRAFT3	Jan 12, 2016	Updated in accordance with comments from the IEC 60950-1 safety testing at TUV (see Interim Test Summary_75932207_Issue1): Clarified part numbering in section 2.1. Clarified number of power supplies and the nominal and maximum voltage and maximum current in section 3.2.1 and included recommendation to incorporate a current limiting device in the host application. Added details on requirements of the enclosure provided by the host product/application in section 2.2. Updated Declaration of Conformity.
7.2 DRAFT4	Jan 28, 2016	Updated in accordance with comments from the IEC 60950-1 safety testing at TUV (see Interim Test Summary_75932207_Issue2).

Export Compliance Information

This product is controlled by the export laws and regulations of the United States of America. The U.S. Government may restrict the export or re-export of this product to certain individuals and/or destinations. For further information, contact the U.S. Department of Commerce, Bureau of Industry and Security or visit www.bis.doc.gov.

Contents

Revision History	3
Contents	5
List of Abbreviations	6
1 Product Overview	7
1.1 Key Features	7
1.2 Iridium Core 9523/9523N Packaging and Regulatory Certification	7
1.3 Software Revision	8
1.1 Unauthorised Changes	9
1.1 Radio Interference	9
1.2 RF Exposure	9
1.3 FCC Class B Digital Device Notice	10
1.4 Labelling Requirements for the Host device	10
1.5 CAN ICES-3 (B) / NMB-3 (B)	11
1.6 R&TTE Statement	11
1.7 Reference	13
2 Physical Specification	14
2.1 Dimensions and Layout	16
2.1 Part Numbering	17
2.2 Field Application Board Mounting	18
2.3 Environmental	21
2.3.1 Environmental Specification	21
2.3.2 Environmental Tests	21
3 Electrical Interfaces	23
3.1 User Connector	23
3.1.1 User Connector Type	23
3.1.2 User Connector Pin Allocation	24
3.2 DC Power Supply Interface	26
3.2.1 DC Power Supply Inputs	26
3.2.2 Power On/Off Control, TRX_ON	27
3.2.3 Typical Power Usage Profile	27
3.3 PCM Digital Audio	29
3.3.1 Port 1	30
3.3.2 Port 2	30
3.3.3 11Hz Signal for Manufacturing and Regulatory Testing	31
3.4 DPL port	31
3.5 Data/Fax port	31
3.6 SIM interface	31
3.7 GPIO Signals	32
3.7.1 Transmit power Control	32
3.7.2 External GPS Receiver Switch	32
3.7.3 Modem/Handset Mode Select Signal	32
4 RF Interface	32
4.1 RF Connector Type	32
4.1.1 Antenna Characteristics	33
4.2 RF Interface Specifications	33
4.3 Radio Characteristics	34
4.4 S-meter Performance	34
5 AT Interface	34

List of Abbreviations

Abbreviation	Description
CE	Conformité Européene
CTS	(V.24 signal) Clear To Send. This signal is used to control the flow of data to the Iridium Core 9523
DC	Direct Current
DCD	(V.24 signal) Data Carrier Detect
DCE	Data Communications Equipment. In this Product, DCE refers to the Iridium Core 9523
DSR	(V.24 signal) Data Set Ready. This signal, from the Iridium Core 9523, indicates readiness to accept communication over the data port
DTE	Data Terminal Equipment. In this Product, DTE refers to the FA
DTR	(V.24 signal) Data Terminal Ready. This signal, from the FA, requests the Iridium Core 9523 to accept communication over the data port
ESD	Electro-static Discharge
FA	Field Application; the application controlling the Iridium Core 9523
FCC	Federal Communications Commission
GND	Ground
GSS	Gateway SBD Subsystem (synonymous with ESS)
IC	Industry Canada
IMEI	International Mobile Equipment Identity
LBT	L-Band Transceiver
MO	Mobile Originated
MOMSN	Mobile Originated Message Sequence Number
MT	Mobile Terminated
MTMSN	Mobile Terminated Message Sequence Number
PCM	Pulse Code Modulation
RHCP	Right Hand Circular Polarization
RI	(V.24 signal) Ring Indicate. This signal, from the Iridium Core 9523, indicates that an MT message is present at the GSS
RTS	(V.24 signal) Request To Send. This signal is used to control the flow of data from the Iridium Core 9523.
SBD	Short Burst Data
SMS	Short Message Service
TBA	To Be Advised
UART	Universal Asynchronous Receiver Transmitter
VAM	Value Added Manufacturer
VAR	Value Added Reseller
VSWR	Voltage Standing Wave Ratio

1 Product Overview

1.1 Key Features

The Iridium Core 9523/9523N is a voice and data transceiver module for the Iridium global satellite network. It is designed to be integrated with field application (FA) hardware and software to produce a solution designed for a specific application or vertical market. These solutions drive a wide range of applications in industries such as Oil and Gas, Rail, Maritime, Aeronautical, Utilities and Government/Military.

The Iridium Core 9523/9523N is designed to meet the regulatory requirements for approval for FCC, Canada, and CE assuming an antenna with a gain of ~3 dBi and adequate shielding.

The Iridium Core 9523/9523N supports all Iridium's voice and data services. Applications can be built to use one or multiple services using the voice and data interfaces. The product provides the core transceiver module. All other functions and hardware such as SIM card reader, keypad, display, power supply antenna etc. must be provided by the Product Developer. The Iridium Core 9523/9523N consists of the following:

- Iridium radio transceiver with 8 watt transmitter and dual receivers
- Call Processor function that implements the Iridium L-Band AIS protocol
- Iridium speech Vocoder
- Coaxial RF connector for the antenna
- 40-way inter-PCB connector with the following interfaces:
 - Digital audio interfaces
 - DPL serial asynchronous control port
 - Serial asynchronous interface for SIM
 - Data/Fax port – serial asynchronous data plus 6 control signals
 - GPIO control signals
 - Power

The Iridium Core 9523N is a second generation version of the Iridium Core 9523 and is identical in form and function to the Iridium Core 9523. This document applies to both the Iridium Core 9523 and Iridium Core 9523N as indicated by the term 'Iridium Core 9523/9523N'. Where the contents of this document apply specifically to either the Iridium Core 9523 or Iridium Core 9523N then this is indicated by the use of the terms 'Iridium Core 9523' and 'Iridium Core 9523N' respectively.

The Iridium Core 9523/9523N is described within this document as "9523/9523N" and "ISU." All of these terms refer to the same product.

1.2 Iridium Core 9523/9523N Packaging and Regulatory Certification

The Iridium Core 9523/9523N is a regulatory approved daughter module transceiver that can be fitted within an enclosed host system. With appropriate external connections, the host system can be designed to meet full transceiver regulatory tests and sold as a Regulatory Certified product that meets CE, FCC and IC requirements.

The Iridium Core 9523 is tested to the regulatory and technical certifications shown in Table 1. The Iridium Core 9523N is tested to the regulatory and technical certifications shown in Table 2.

Table 1: Iridium Core 9523 Regulatory and Technical Certifications

Regulatory Approvals	Radio Tests	EMC Tests	Electrical / Mechanical / Operational Safety Tests
CE	ETSI EN 301 441 V1.1.1 (2000-05)	ETSI EN 301 489-1 V1.8.1 (2008-04) ETSI EN 301 489-20 V1.2.1 (2002-11)	EN60950-1:2006 Part 1
FCC	FCC CFR47 parts 2, 15, and 25	EN61000-4-2 : 1995/A2 : 2001 Part 4.2 EN61000-4-3 : 2002 Part 4.3 EN61000-4-4 : 2004 EN61000-4-6 : 1996/A1 : 2001 Part 4.6 EN55022:2006	
Industry Canada	RSS170 Issue 2, March, 2011		

Table 2: Iridium Core 9523N Regulatory and Technical Certifications

Regulatory Approvals	Radio Tests	EMC Tests	Electrical / Mechanical / Operational Safety Tests
CE	ETSI EN 301 441 V1.1.1 (2000-05)	ETSI EN 301 489-1 V1.9.2 (2011-09) ETSI EN 301 489-20 V1.2.1 (2002-11)	EN 60950-1:2006 /A12:2011/A2:2013 AS/NZS 60950.1: 2011/A1:2012
FCC	FCC CFR47 parts 2 (2014), 15B (2014), and 25 (2014)	EN61000-4-2 : 2009 EN61000-4-3 : 2006+A2:2010 EN61000-4-4 : 2012 EN61000-4-6 : 2013 EN55022:2010	
Industry Canada	RSS170 Issue 3, Jul 2015 RSS-GEN Issue 4, Nov 2014 ICES-003 Issue 5, Aug 2012		

1.3 Software Revision

Product Developers should read this document in conjunction with the “Software Release Notes” relevant to the revision of the software that is loaded into their Iridium Core 9523/9523N. The software release notes are available on the Iridium for Partners section of the Iridium.com website.

There may be multiple software releases over the lifespan of the Iridium Core 9523/9523N. A software upgrade utility is provided with each software release. The utility runs on a Windows-compatible OS and will automatically upgrade the modem with the latest version.

Production procedures for finished goods should ensure that the appropriate software release is loaded on each Iridium Core 9523/9523N module used. The software release loaded on a particular Iridium Core 9523/9523N module can be read out using the AT command interface.

1.1 *Unauthorised Changes*

Iridium has not approved any changes or modifications to this device by the user. Any changes or modifications could void the user's authority to operate the equipment.

Iridium n'approuve aucune modification apportée à l'appareil par l'utilisateur, quelle qu'en soit la nature. Tout changement ou modification peuvent annuler le droit d'utilisation de l'appareil par l'utilisateur.

1.1 *Radio Interference*

This device complies with Part 15 of the FCC Rules and Industry Canada licence-exempt RSS standard(s). Operation is subject to the following two conditions: (1) this device may not cause interference, and (2) this device must accept any interference, including interference that may cause undesired operation of the device.

Under Industry Canada regulations, this radio transmitter may only operate using an antenna of a type and maximum (or lesser) gain approved for the transmitter by Industry Canada. To reduce potential radio interference to other users, the antenna type and its gain should be so chosen that the equivalent isotropically radiated power (EIRP) is not more than that necessary for successful communication.

Le présent appareil est conforme aux CNR d'Industrie Canada applicables aux appareils radio exempts de licence. L'exploitation est autorisée aux deux conditions suivantes : (1) l'appareil ne doit pas produire de brouillage, et (2) l'utilisateur de l'appareil doit accepter tout brouillage radioélectrique subi, même si le brouillage est susceptible d'en compromettre le fonctionnement.

Conformément à la réglementation d'Industrie Canada, le présent émetteur radio peut fonctionner avec une antenne d'un type et d'un gain maximal (ou inférieur) approuvé pour l'émetteur par Industrie Canada. Dans le but de réduire les risques de brouillage radioélectrique à l'intention des autres utilisateurs, il faut choisir le type d'antenne et son gain de sorte que la puissance isotrope rayonnée équivalente (PIRE) ne dépasse pas l'intensité nécessaire à l'établissement d'une communication satisfaisante.

1.2 *RF Exposure*

This equipment complies with FCC and IC radiation exposure limits set forth for an uncontrolled environment. The antenna should be installed and operated with minimum distance of 20 cm between the radiator and your body. Antenna gain must be below: 3.0 dBi. This transmitter must not be co-located or operating in conjunction with any other antenna or transmitter.

Cet appareil est conforme aux limites d'exposition aux rayonnements de la IC pour un environnement non contrôlé. L'antenne doit être installée de façon à garder une distance minimale de 20 centimètres entre la

source de rayonnements et votre corps. Gain de l'antenne doit être ci-dessous: 3.0 dBi. L'émetteur ne doit pas être colocalisé ni fonctionner conjointement avec à autre antenne ou autre émetteur.

1.3 FCC Class B Digital Device Notice

This equipment has been tested and found to comply with the limits for a Class B digital device, pursuant to part 15 of the FCC Rules. These limits are designed to provide reasonable protection against harmful interference in a residential installation. This equipment generates, uses and can radiate radio frequency energy and, if not installed and used in accordance with the instructions, may cause harmful interference to radio communications. However, there is no guarantee that interference will not occur in a particular installation. If this equipment does cause harmful interference to radio or television reception, which can be determined by turning the equipment off and on, the user is encouraged to try to correct the interference by one or more of the following measures:

- Reorient or relocate the receiving antenna.
- Increase the separation between the equipment and receiver.
- Connect the equipment into an outlet on a circuit different from that to which the receiver is connected.
- Consult the dealer or an experienced radio/TV technician for help.

1.4 Labelling Requirements for the Host device

The host device shall be properly labelled to identify the modules within the host device. The certification label of the module shall be clearly visible at all times when installed in the host device, otherwise the host device must be labelled to display the FCC ID and IC of the module, preceded by the words "Contains transmitter module", or the word "Contains", or similar wording expressing the same meaning, as follows:

Iridium Core 9523

Contains FCC ID: Q639523 or Contains transmitter module FCC ID: Q639523
Contains IC: 4629A-9523 or Contains transmitter module IC: 4629A-9523

Iridium Core 9523N

Contains FCC ID: Q639523N or Contains transmitter module FCC ID: Q639523N
Contains IC: 4629A-9523N or Contains transmitter module IC: 4629A-9523N

L'appareil hôte doit être étiqueté comme il faut pour permettre l'identification des modules qui s'y trouvent. L'étiquette de certification du module donné doit être posée sur l'appareil hôte à un endroit bien en vue en tout temps. En l'absence d'étiquette, l'appareil hôte doit porter une étiquette donnant le FCC ID et le IC du module, précédé des mots « Contient un module d'émission », du mot « Contient » ou d'une formulation similaire exprimant le même sens, comme suit:

Iridium Core 9523

Contains FCC ID: Q639523 or Contains transmitter module FCC ID: Q639523
Contains IC: 4629A-9523 or Contains transmitter module IC: 4629A-9523

Iridium Core 9523N

Contains FCC ID: Q639523N or Contains transmitter module FCC ID: Q639523N
Contains IC: 4629A-9523N or Contains transmitter module IC: 4629A-9523N

1.5 CAN ICES-3 (B) / NMB-3 (B)

This Class B digital apparatus complies with Canadian ICES-003¹.

Cet appareil numérique de classe B est conforme à la norme canadienne ICES-003².

1.6 R&TTE Statement

Iridium Communications Inc. hereby declares that the 9523N is in compliance with the essential requirements and other relevant provisions of Directive 1999/5/EC. A copy of the Declaration of Conformity is given below.

¹Applicable to 9523N only.

²Applicable à 9523N seulement.

E C Directive

Declaration of Conformity

We, Iridium Satellite LLC of 1750 Tysons Blvd, Suite 1400, McLean, VA 22102 USA declare under our sole responsibility that the product '9523N Voice and Data Satellite Transceiver Module', to which this declaration relates, is in conformity with the following standards and/or other normative documents:

Standard	Description
EN 60950-1:2006/A12:2011/A2:2013 AS/NZS 60950.1:2011/A1:2012	Information technology equipment – Safety – Part 1: General requirements
EN 62311:2008	Assessment of electronic and electrical equipment related to human exposure restrictions for electromagnetic fields (0 Hz - 300 GHz)
EN 301 489-01 V1.9.2 (2011-09)	Electromagnetic compatibility and Radio spectrum Matters (ERM); ElectroMagnetic Compatibility (EMC) standard for radio equipment and services; Part 1: Common technical requirements
EN 301 489-20 V1.2.1 (2002-11)	Electromagnetic compatibility and Radio spectrum Matters (ERM); ElectroMagnetic Compatibility (EMC) standard for radio equipment and services; Part 20: Specific conditions for Mobile Earth Stations (MES) used in the Mobile Satellite Services (MSS)
EN 301 441 V1.1.1 (2000-05)	Satellite Earth Stations and Systems (SES); Harmonized EN for Mobile Earth Stations (MESs), including handheld earth stations, for Satellite Personal Communications Networks (S-PCN) in the 1,6/2,4 GHz bands under the Mobile Satellite Service (MSS) covering essential requirements under Article 3.2 of the R&TTE directive

We hereby declare that all essential radio test suites have been carried out and that the above named product is in conformity to all the essential requirements of Directive 1999/5/EC. The conformity assessment procedure referred to in Article 10 and detailed in Annex IV of Directive 1999/5/EC has been followed with the involvement of the following Notified Body: TÜV SÜD BABT, Octagon House, Concorde Way, Segensworth North, Fareham, Hampshire, PO15 5RL, UK.

The technical documentation relevant to the above equipment will be held at Iridium Satellite LLC, 1750 Tysons Blvd, Suite 1400, McLean, VA 22102 USA.



Hermon Pon
Vice President, Technology Development & Network Engineering

Iridium Satellite LLC
January 8, 2016

1.7 Reference

- [1] ITU-T Recommendation V.25ter, 08/95
- [2] ETS 300 642: Digital Cellular Telecommunications System (Phase 2); AT Command Set for GSM Mobile Equipment (GSM 07.07)
- [3] ETS 300 585: Digital Cellular Telecommunications System (Phase 2); Use of DTE-DCE Interface SMS and CBS (GSM 07.05)
- [4] ETS 300 520: Digital Cellular Telecommunications System (Phase 2) (GSM); Call Barring (CB) Supplementary Services – Stage 1 (GSM 02.88)
- [5] ETS 300 511: Digital Cellular Telecommunications System (Phase 2) (GSM); Man–Machine Interface (MMI) of the Mobile Station (MS) (GSM 02.30)
- [6] ETS 300 516: Digital Cellular Telecommunications System (Phase 2) (GSM); Call Waiting (CW) and Call Hold (HOLD) Supplementary Services; Stage 1 (GSM 02.83)
- [7] ETS 300 557: Digital Cellular Telecommunications System (Phase 2) (GSM); Mobile radio interface; Layer 3 Specification (GSM 04.08)
- [8] ETS 300 559: Digital Cellular Telecommunications System (Phase 2) (GSM); Point-to-Point (PP) Short Message Service (SMS) support on mobile radio interface (GSM 04.11)
- [9] ETS 300 536: Digital Cellular Telecommunications System (Phase 2) (GSM); Technical realization of Short Message Service (SMS) Point-to-Point (PP) (GSM 03.40)
- [10] ETS 300 537: Digital Cellular Telecommunications System (Phase 2) (GSM); Technical realization of Short Message Service Cell Broadcast (SMSCB) (GSM 03.41)
- [11] ETS 300 515: Digital Cellular Telecommunications System (Phase 2) (GSM); Call Forwarding (CF) Supplementary Services (GSM 02.82)
- [12] 3GPP TS 27.007: 3rd Generation Partnership Project; Technical Specification Group Terminals; AT command set for User Equipment (UE)

2 Physical Specification

For illustrative purposes, pictures of the Iridium Core 9523 and Iridium Core 9523N, fitted with its aluminum shielding frame, are shown in Figure 1 and Figure 2 respectively.

Figure 1: Photos of Iridium Core 9523

Top View



Bottom View

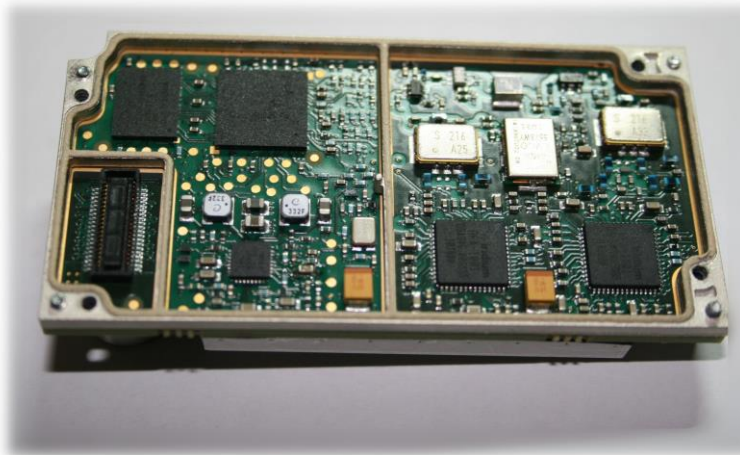

Left View



Figure 2: Photos of Iridium Core 9523N



Top View

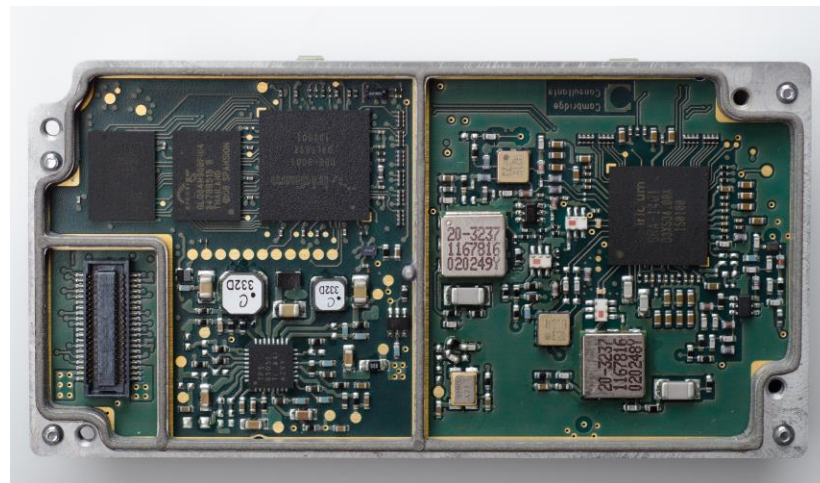

Bottom View



Left View

2.1 Dimensions and Layout

The overall dimensions of the Iridium Core 9523 and its weight are summarized in Table 3 and represented graphically in Figure 3.

Table 3: Iridium Core 9523 Mechanical Dimensions

Parameter	Value
Length	70.44 mm
Width	36.04 mm
Height (from FA board)	14.6 mm max (reservoir capacitors) 8.9 mm (screening can)
Weight (approximate)	32g

The Iridium Core 9523/9523N consists of a single PCB with components mounted on top and bottom sides.

On the top side, there are three reservoir capacitors, the RF connector, and a screening can covering all the remaining circuits.

The bottom side has a Molex 40-pin multi-way user interface connector. The bottom side does not have a screening can, but instead the PCB artwork has an exposed ground ring all around the edge of the board. This ground ring makes contact with an aluminum screening frame, attached to the Iridium Core 9523/9523N by four corner thread-forming screws. The tips of these screws protrude through the aluminum frame and act as alignment pins when mounting onto the FA board. The aluminum frame also has at its center a 1.0mm diameter alignment pin.

There are a further four corner screw holes through the aluminum frame and PCB for securing the Iridium Core 9523/9523N to the FA board.

The two height values provided in Table 3 do not include the height of the compressible gasket on the bottom of the Iridium Core 9523/9523N that will mate to the FA board. It is assumed that this gasket will compress to near zero thickness if screws are torqued sufficiently.

Figure 3: Dimensions of the Iridium Core 9523/9523N

(Dimensions in millimeters)

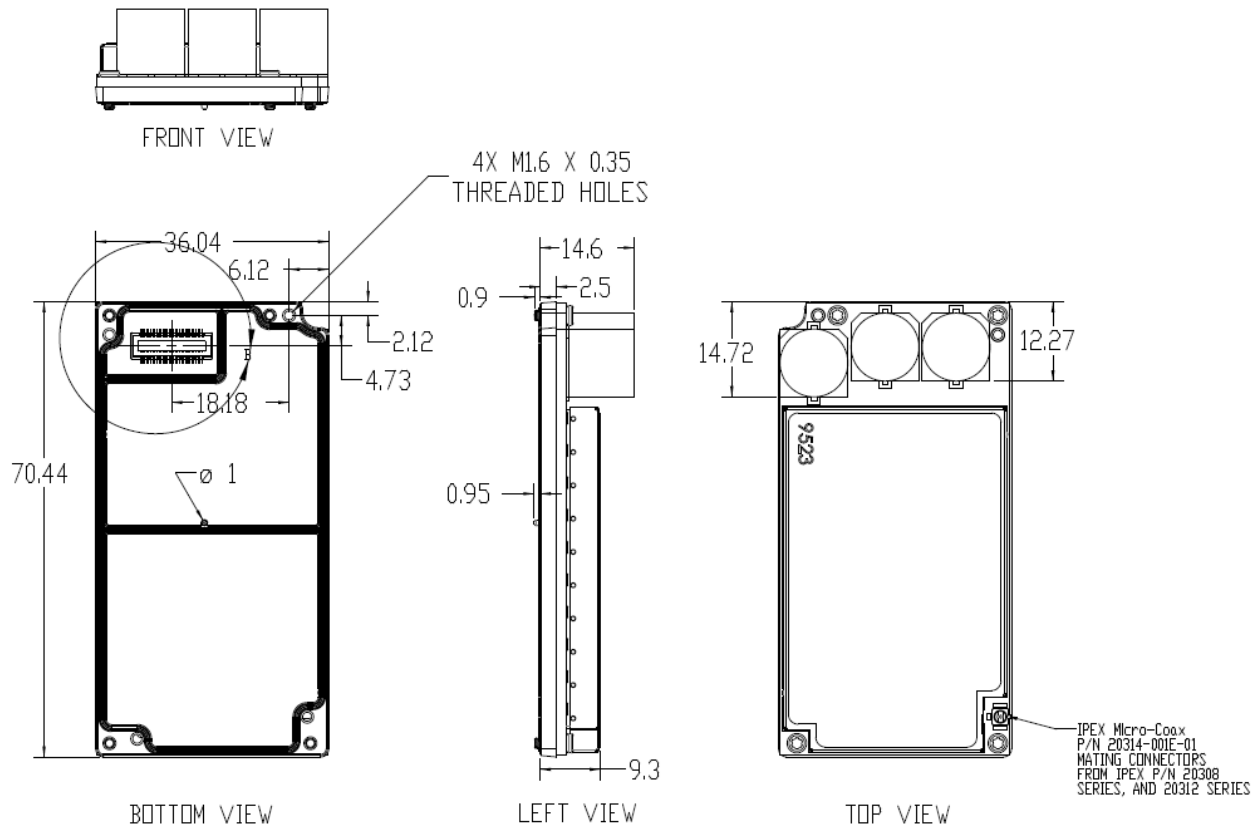

2.1 Part Numbering

The part numbers for the Iridium Core 9523/9523N are as shown in Table 4. The part number is stated on the product label.

Table 4: Iridium Core 9523/9523N Part Numbering

Model	Part Number
Iridium Core 9523	IRID0125X
Iridium Core 9523N	IRIDN0125X

2.2 Field Application Board Mounting

The Iridium Core 9523/9523N is designed to be mounted to an FA board as illustrated in Figure 4.

Figure 4: Illustration of mounting module to application board

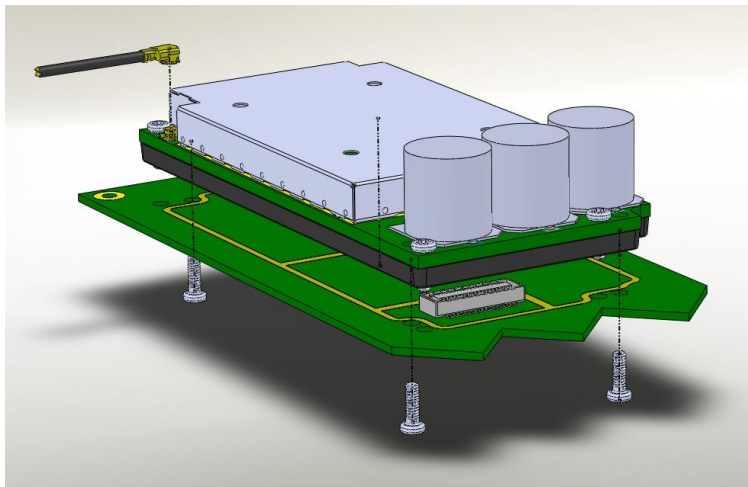

The FA board must have a socket mating to the Molex 40-pin multi-way user interface connector on the bottom of the Iridium Core 9523/9523N. See section 3.1.1 for the connector part number. The Molex connectors and aluminum frame set the separation between the Iridium Core 9523/9523N and FA boards at 2.5 mm.

In order to meet type approval standards for EMC, the FA board should include a ground ring and a good ground layer on its top surface to act as the fifth side of the screening can.

The layout of the mounting location for the Iridium Core 9523/9523N on the FA board – including the locations and diameters of all nine holes, layout of the grounding ring, and identification of areas with different grounding requirements – is shown in Figure 5. A CAD file showing this information in DXF format can be obtained from Iridium in order to assist layout of FA boards.

The FA board must have screw holes lining up with the Iridium Core 9523/9523N's four 1.8mm corner mounting screw holes. The Iridium Core 9523/9523N must be secured to the FA board with four M1.6x0.35 screws through these holes. The FA board must also have four corner alignment holes and one center alignment hole lining up, respectively, with the Iridium Core 9523/9523N's four 1.6mm corner protruding screws and one 1mm center alignment pin. The screw holes should be at least 1.8mm and the alignment hole at least 1.2mm, but they may be made slightly larger for greater tolerance. In Figure 5 below, one of the screw holes is 2.08mm, providing the primary alignment, while the other three screw holes are 2.1mm. In the same figure, the center alignment hole is 1.3mm. These dimensions are recommendations; other dimensions may be used so long as the Iridium Core 9523/9523N is properly aligned with the user interface connector and ground trace.

In Figure 4, area 'A' of the FA board sits under sensitive analog circuitry on the Iridium Core 9523/9523N's bottom side, and it is essential that no components or tracks on the FA board appear in this area; it must be filled entirely with a solid ground plane on the top layer of the FA board.

Area 'D' sits under digital and power circuits. Ideally, this will also be shielded with a solid ground plane. However, it is acceptable to place tracks and low-profile components in area 'D', so long as care is taken to avoid mechanical clashes and due consideration is taken of EMC issues.

Area 'C' contains the Molex user interface connector and should be free of surface copper.

The FA board must provide a sufficient margin free of conductive elements around the Iridium Core 9523/9523N perimeter in order to avoid electrical shorts with the Iridium Core 9523/9523N. This is indicated by the 'SMT Placement Keepout Zone'.

Partner solutions must be provide sufficient clearance above the conductive capacitors and shield can on the top of the Iridium Core 9523/9523N to prevent an electrical short.

When operating the Iridium Core 9523/9523N at ambient temperatures of 50°C or greater, the external surface temperature of the Iridium Core 9523/9523N may exceed 70°C. In the case where the ambient temperature in the host product incorporating the Iridium Core 9523/9523N can exceed 50°C, the host product must prevent direct access to the Iridium Core 9523/9523N module by the end user/operator in order to comply with EN 60950-1 clause 4.5.

It is recommended that Iridium Core 9523/9523N be powered from a Limited Power Supply (LPS)³ as detailed in EN60950-1 clause 2.5. Where this is not the case then the host product that incorporates the Iridium Core 9523/9523N must provide the electrical enclosure, mechanical enclosure and fire enclosure for the Iridium Core 9523/9523N in order to comply with EN60950-1 clause 1.7.

³ An LPS is a power supply where the maximum supply power is limited to 100VA.

Figure 5: Mounting location dimensions and layout
(Dimensions in millimeters)

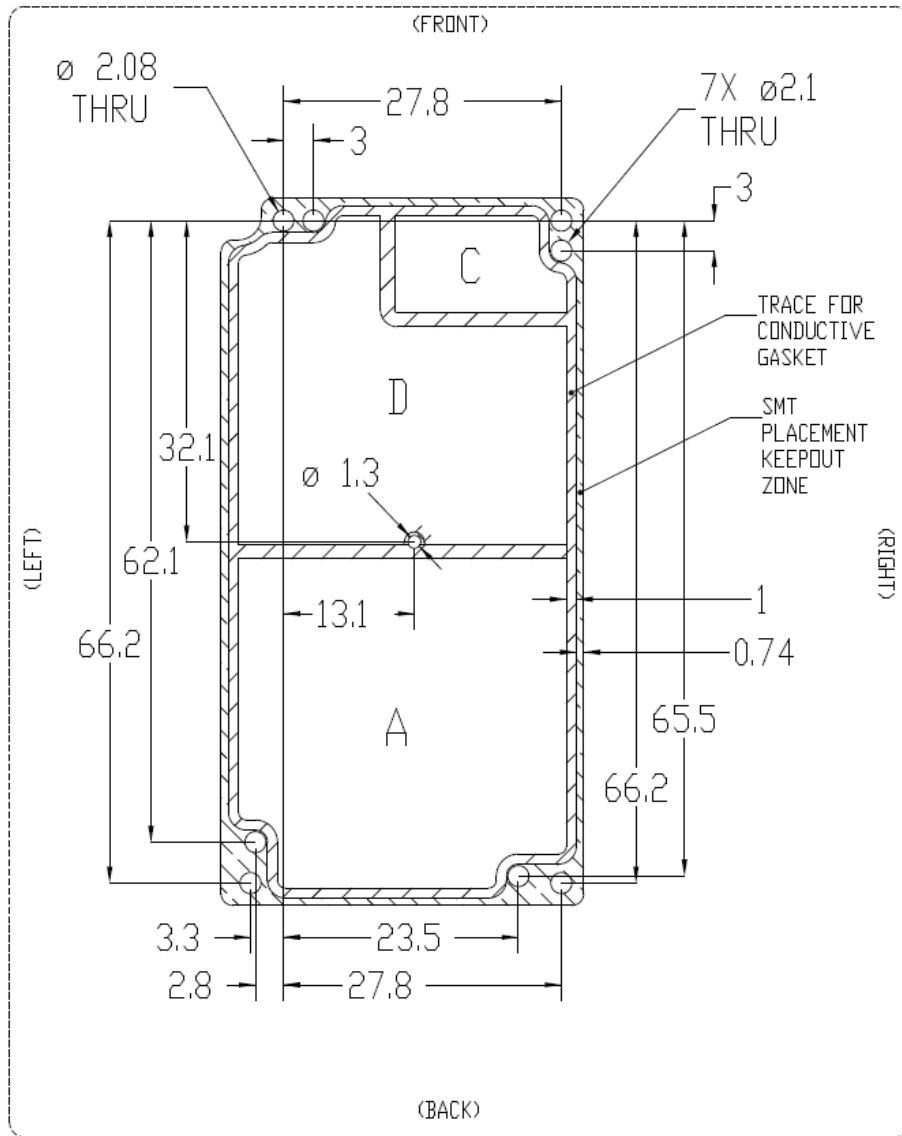

APPLICATION BOARD MOUNTING HOLE LOCATIONS
(ALL DIMENSIONS $\pm 0.15\text{mm}$)

2.3 Environmental

2.3.1 Environmental Specification

The environmental specifications of the Iridium Core 9523/9523N are summarized in Table 5 below.

Table 5: Environmental Specifications

Parameter	Value
Operating Temperature Range	-30°C to +70°C
Operating Humidity Range	≤ 75% RH
Storage Temperature Range	-40°C to +85°C
Storage Humidity Range	≤ 93% RH

2.3.2 Environmental Tests

An Iridium system that incorporates the Iridium Core 9523 has passed the tests listed in Table 6. The Iridium Core 9523N has passed the tests in Table 7. It is expected that a system incorporating the Iridium Core 9523/9523N designed according to this document should also pass these tests.

Table 6: Iridium Core 9523 Environmental Tests

Test Name	Test Reference	Test Description
IEC	Vibration (IEC60068-2-64)	Mount unit to a vibration table and excite between 15 and 500 Hz
MIL-STD-810GF	Low Pressure (500.4 - II)	Decrease pressure to 57.2 kPa (equivalent to 15,000 ft) at a rate not to exceed 10 m/s and hold for 1 hour
	High Temperature (501.4 - I)	Over 24 hours, cycle the unit from 33°C to 71°C and back to 33°C. Repeat 7 times.
	High Temperature (501.4 - II)	Test is a subset of High Temperature 501.4 - Part I, focused on the first three cycles.
	Low Temperature (502.4 - I)	Soak unit for 24 hours at -45°C
	Low Temperature (502.4 - II)	Soak unit for 4 hours at -10°C
	Temperature Shock (503.4 - I)	Soak unit at -40C for 4 hours. Transfer to 85C chamber and soak additional 4 hours. Repeat 3 times. Each transfer from one temperature environment to the other should be made in less than 1 minute.
	Vibration (514.5 - I, Cat. 8)	Secure unit to a vibration table and excite randomly from 15-2000 Hz at 0.01 - 0.03 g ² /Hz.
Shock (516.4 - I)	Expose unit to 3 shocks of 40g over approximately 11ms in each of 3 primary axes (9 total shocks).	

Table 7: Iridium Core 9523N Environmental Tests

Test Name	Test Reference	Test Description
IEC	Change of Temperature (EN60068-2-14 2009)	Five cycles of 1 hour each from -30°C to +70°C.
	Mechanical Shock (EN60068-2-27 2009)	Mount unit on a vibration table and excite with three half sine pulses in each of three axis (pulse peak amplitude: 10g, pulse duration: 11ms).
	Vibration (EN60068-2-64 2008)	Mount unit on a vibration table and excite from 5Hz to 20Hz at 0.96m ² /s ³ and from 21Hz to 500Hz at 0.96m ² /s ³ rolling of at -3dB per octave for 1 hour per axis in each of three axes.
	Damp Heat Steady State (EN60068-2-78 2012)	40°C, 93%RH for 4 days
SAE	Thermal Shock SAE J1455:2012 Section 4.1.3.2	Five cycles of 2 hours each from -40°C to +85°C.
	Handling Drop Test SAE J1455:2012 Section 4.11.3.1	Drop from a height of 1m onto a concrete surface, one time in each of the three mutually perpendicular planes (three drops in total).
	SAE J1455:2012 Section 4.10.4.2 Vibration	Mount unit on a vibration table and excite from 10 Hz to 40 Hz at 0.02g ² /Hz and from 40 Hz to 500 Hz at 0.02g ² /Hz dropping of at -6 dB per octave for 1 hour per axis in each of three axes.
MIL-STD-810G	Low Pressure Method 500.5 Procedure II - Operation/Air Carriage	Decrease pressure to 57.2 kPa (equivalent to 15,000 feet) at a rate not to exceed 10 m/s at a temperature of 23°C ±3°C and hold for 1 hour.
	High Temperature Method 501.5 Procedure I – Storage	Over 24 hours, cycle the unit from 35°C to 71°C and back to 35°C. Repeat 7 times.
	High Temperature Method 501.5 Procedure II - Operation	This test is a subset of the High Temperature test (Method 500.5, Procedure – I) in which the operation is verified at 71°C over the first 3 cycles of Procedure I.
	Low Temperature Method 502.5 Procedure I – Storage	Ramp from ambient conditions to -45°C ±2°C in 1 hour. Soak at -45°C for 24 hours. Ramp from -45°C to ambient conditions in 1 hour.
	Low Temperature Method 502.5 Procedure II – Operation	Ramp from ambient conditions to -10°C ±2°C in 1 hour. Soak at -10°C for 24 hours. Ramp from -10°C to ambient conditions in 1 hour.
	Temperature Shock Method 503.5 Procedure I-C	Soak at -40°C for 4 hours. Transfer to +85°C and soak for an additional 4 hours. Repeat 4 times (4 cold to hot transitions and 4 hot to cold transitions).
	Humidity Method 507.5 Procedure II – Aggravated	Held at 95% RH with the ambient temperature changed from 30°C to 60°C and then down to 20°C over a 48 hour cycle, with the cycle repeated 5 times.
	Vibration Method 514.6 Procedure I – General Vibration (Category 8)	Secure unit to a vibration table and excite randomly with the following profile: Category 8:15-2000 Hz, L ₀ =0.30 g ² /Hz, f ₀ = 68 Hz, 1 hour per axis in each of 3 axes.
	Shock Method 516.6 Procedure I – Functional Shock	Expose unit to 3 shocks of 40g over approximately 11ms in +/- direction of each of the 3 primary axes (18 total shocks).

Electrical Interfaces

The following subsections contain information for the electrical interfaces of the Iridium Core 9523/9523N for the non-RF connections. The RF interface is covered in Section 0.

3.1 User Connector

Table 8 lists the connections to the Iridium Core 9523/9523N on the user connector.

Table 8: Signal Groups on User Connector

Signal group	Signal function
PCM Digital Audio	Two synchronous serial interfaces carrying 16-bit, 8 kHz sample rate PCM audio data Each port has 4 wires – data in each direction, clock and frame signals Only one digital audio port is in use at any time Port 1 has a secondary function during factory testing, to carry the 90ms frame synchronization from the test equipment
DPL port	Serial asynchronous control interface 2 wires – data in each direction
Data/Fax port	Serial asynchronous control interface 8 wires – data in each direction plus control signals The full set of control signals may be used for a Data/Fax port
SIM interface	Standard SIM signals 5 wires – data, clock, reset, enable, voltage select
Power	Battery Supply to Iridium Core 9523/9523N 5 power pins – 3x battery voltage and 2x boost voltage 6 grounds 1 boost regulator control line (PA_BOOST_EN)
GPIO, antenna configuration	2 wires – ANT_DET_PWR and FULL_POWER_EN. Signals provided as a mechanism to restrict the transmitted power – for example in order to meet SAR standards.
Other GPIO	2 wires – TX_ACTIVE which may be used as an output to indicate when the transmitter is active, and LBT_HSTB which determines the operating mode of the software on the Iridium Core 9523/9523N.

3.1.1 User Connector Type

The connector on the Iridium Core 9523/9523N is a 40-way, 0.5 mm pitch Molex low-profile header connector, part number 54102-0404.

This connector provides the ability for a stackable board-to-board configuration, allowing connection to the host system motherboard via a mating 53885-0408 socket.

Data sheets on these connectors can be found at: <http://www.molex.com>

Pin numbering schemes for the Molex connectors on the Iridium Core 9523/9523N and the host FA board are shown in Figure 6 (both pictures show the pin-out when looking down onto the boards).

Figure 6: Pin numbering scheme for User Connector

Molex 54102-0404 on Iridium Core 9523/9523N:

Molex 53885-0408 on FA PCB:

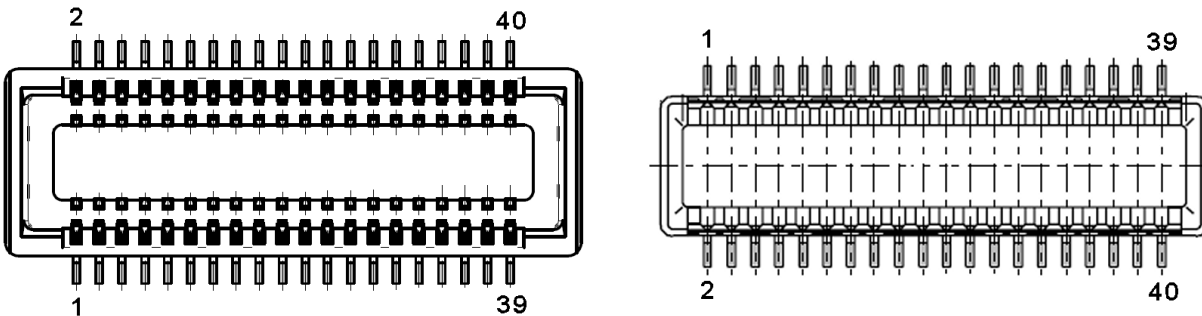
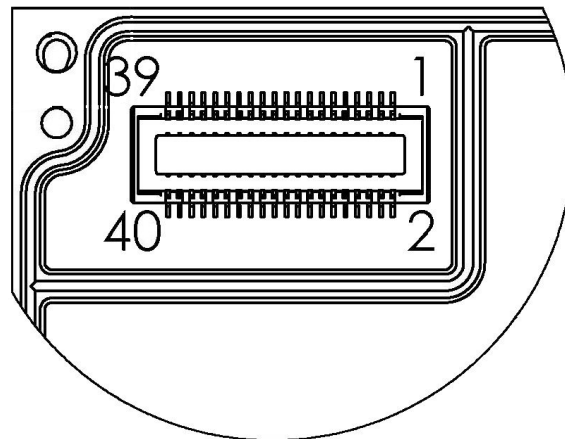

Figure 7 provides a reference for the pin designation and shows the connector's location and rotation with respect to the corner of the Iridium Core 9523/9523N board. This view is for illustrative purposes only. This view designation is when looking into the user connector towards the Iridium Core 9523/9523N.

Figure 7: User Connector Pin Number Designation



3.1.2 User Connector Pin Allocation

The user connector is a 2-row 40-way header. Individual pin assignments are shown in Table 9 and the limits for the digital signals are listed in Table 10. Multiple supply grounds are provided and all supply rails and supply grounds are required to be connected to the power supply in order to limit the current on any one pin.

Note that the Iridium Core 9523/9523N provides limited ESD protection on its digital I/O signals: Human Body Model 2kV and Machine Model 200V ESD protection. Partners should design their FA boards to include appropriate ESD protection on these signals.

Table 9: User Connector Pin Allocation

Pin No.	Signal Name	Signal direction (WRT modem)	Signal function	Signal group
1	CODEC_PCMCLK	Out	Clock	PCM audio port 1
2	CODEC_PCMIN	Out	Data from modem	PCM audio port 1
3	CODEC_PCMSYNC	Out	Frame Sync	PCM audio port 1
4	CODEC_PCMOUT	In	Data to modem	PCM audio port 1
5	0V		Ground	Power supply
6	0V		Ground	Power supply
7	UC_DACLK	Out	Clock	PCM audio port 2
8	UC_DATX	Out	Data from modem	PCM audio port 2
9	UC_DAFS	Out	Frame Sync	PCM audio port 2
10	UC_DARX	In	Data to modem	PCM audio port 2
11	0V		Ground	Power supply
12	0V		Ground	Power supply
13	DPL_RXD	In	Data to modem	DPL port
14	DPL_TXD	Out	Data from modem	DPL port
15	DF_RX	Out	Data from modem	Data/Fax port
16	DF_TX	In	Data to modem	Data/Fax port
17	DF_CTS	Out	Clear to Send	Data/Fax port
18	DF_DCD	Out	Carrier Detect	Data/Fax port
19	DF_DSR	Out	Data Set Ready	Data/Fax port
20	DF_RI	Out	Ringing Indication	Data/Fax port
21	DF_RTS	In	Request to Send	Data/Fax port
22	DF_DTR	In	Data Terminal Ready	Data/Fax port
23	SIM_1V8_3V	Out	Voltage select	SIM
24	SIM_CLOCK	Out	Clock	SIM
25	SIM_ENABLE	Out	Enable	SIM
26	SIM_RESET	Out	Reset	SIM
27	SIM_DATA_IO	Bidir	Data	SIM
28	FULL_POWER_EN	In	Enable full RF power	GPIO
29	ANT_DET_PWR	Out	Power for docking cradle detector	GPIO
30	LBT_HSTB	In	Handset/LBT switch	GPIO
31	TX_ACTIVE	Out	Signal to mute GPS receiver	GPIO
32	TRX_ON	In	Enable modem power regulators	Power supply
33	PA_BOOST_EN	Out	Enable boost converter	Power supply
34	0V		Ground	Power supply
35	0V		Ground	Power supply
36	VBAT	In	Battery Voltage	Power supply
37	VBOOST	In	Boost Voltage for PA	Power supply
38	VBAT	In	Battery Voltage	Power supply
39	VBOOST	In	Boost Voltage for PA	Power supply
40	VBAT	In	Battery Voltage	Power supply

Table 10: Limits for 3.3V Digital Signals

Parameter	Symbol	Min	Max	Unit
Input High Voltage	V_{IH}	2.0	5.5	V
Input Low Voltage	V_{IL}	-0.3	0.8	V
Input current	I_{IN}		20	μA
Input capacitance	C_{IN}		10	pF
Output High Voltage	V_{OH}	2.4		V
Output Low Voltage	V_{OL}		0.4	V
Low Level Output Current	I_{OL}		4.4	mA
High Level Output Current	I_{OH}		5.5	mA

3.2 DC Power Supply Interface

3.2.1 DC Power Supply Inputs

The Iridium Core has two DC Power Supply Inputs: VBAT and VBOOST.

3.2.1.1 Battery Power Input, VBAT

VBAT is the input from a Lithium-ion battery or other low-voltage source via the user connector. It must be in the range 3.2 to 6V and capable of supplying a maximum current of 500mA. The VBAT supply specification is given in Table 11.

Table 11: VBAT Specification

Parameter	Value
Maximum voltage	6.0V
Minimum voltage	3.2V
Maximum supply current ⁴	0.5A

3.2.1.2 Boost Power Input, VBOOST

VBOOST - Boost converter input via user connector. See Section 3.2.3 for details. The VBOOST supply specification is given in Table 12.

The Iridium Core 9523/9523N produces the logic signal PA_BOOST_EN to indicate when the external Boost Power voltage must be applied. This signal can be used as the enable signal to an external boost regulator (logic high = VBOOST needed, logic low = VBOOST not needed).

⁴ It is recommended that supply overcurrent protection is provided by the partner application that incorporates the Iridium Core 9523/9523N.

3.2.2 Power On/Off Control, TRX_ON

The input signal TRX_ON is provided to allow the Iridium Core 9523/9523N to be powered off. This signal controls the power regulators on the Iridium Core 9523/9523N.

The Iridium Core 9523/9523N starts up when power is applied and the TRX_ON input is high. As long as the input voltage is applied, logic high on this line turns the Iridium Core 9523/9523N on and a logic low turns it off. If this line is not required then it must be connected directly to the VBAT supply.

Prior to turning off the modem, command AT*P0 should be issued to ensure all memory write activity is completed.

When the Iridium Core 9523/9523N is powered off, the power-on-reset circuit requires 2 seconds for voltages to decay. Product Developers should therefore not reapply power until this time has elapsed after power has reached 0V. If the 2 second wait time is not adhered to, the reset circuit may not operate and the modem could be placed in a non-operational state. The state is not permanent and can be rectified by the above procedure.

Damage may be caused if TRX_ON is high and VBAT is not supplied. Partners must ensure that this condition cannot occur either by generating TRX_ON from VBAT or by adding protection circuitry such as a clamp diode between TRX_ON and VBAT.

3.2.3 Typical Power Usage Profile

The amount of current taken by the Iridium Core 9523/9523N on its two supply rails depends on whether it is active in a call and the 'power step' level that the transmitter is using. The current consumption during a call at the highest power step is shown in Figure 8.

Figure 8: Current Profile of Supply Rails

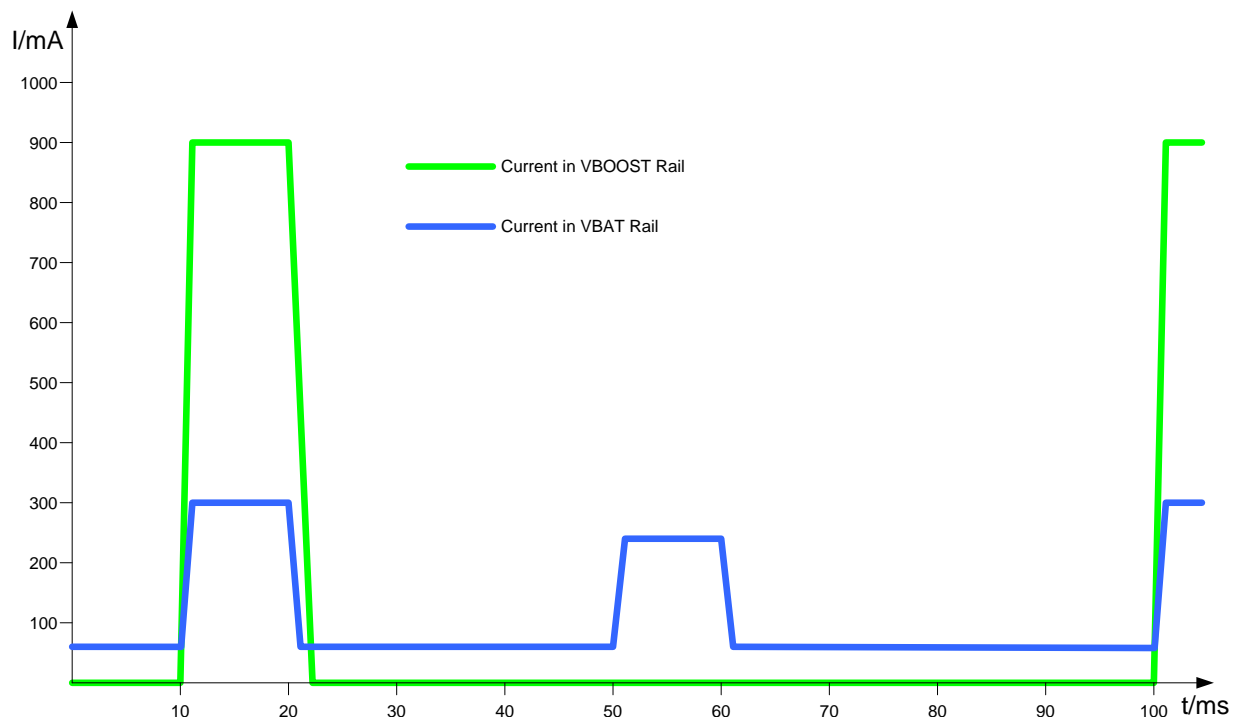

The current peak in the VBOOST rail lasts for 8.3ms and repeats every 90ms (this is the period of a frame in the Iridium air interface). When not transmitting, the VBOOST current returns to zero. The VBOOST current was measured when the Iridium Core 9523/9523N was connected to a 27V power source that could meet its instantaneous power requirements (around 25W).

A block diagram of the VBOOST power supply in a typical Lithium-ion powered application is shown in Figure 9 and Figure 10.

Figure 9: Iridium Core 9523 VBOOST block diagram

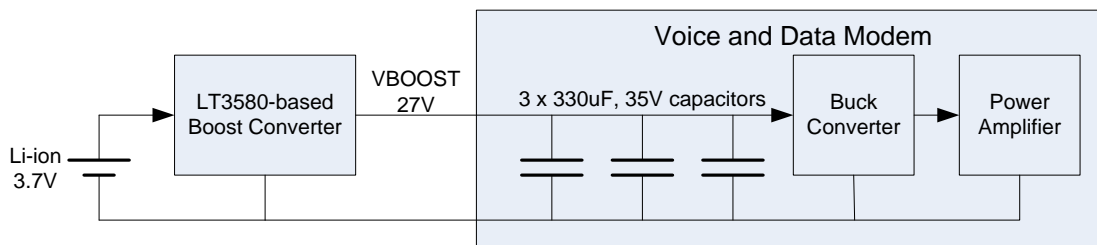
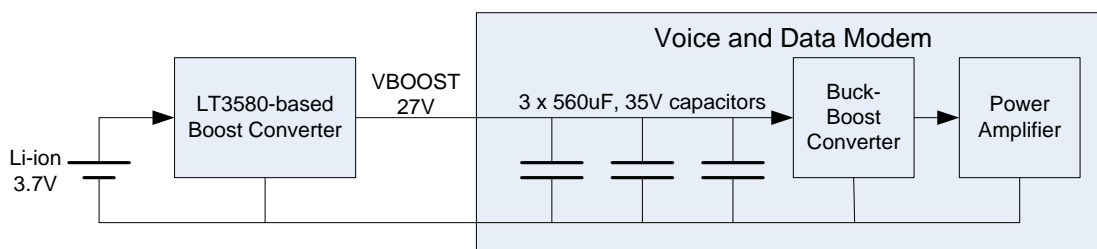

Figure 10: Iridium Core 9523N VBOOST block diagram



Iridium's products use a boost-converter circuit based on the Linear Technology LT3580 to produce the VBOOST rail. This circuit is not capable of supplying the instantaneous current needed by the power amplifier.

The Iridium Core 9523 therefore includes a total capacitance of 990 μ F on the VBOOST rail to store charge; these capacitors are depleted during the transmit time-slot (8.3ms) and replenished during the remainder of the frame time (81.7ms). The voltage across the capacitors at the end of each transmit time-slot must not fall below 10.5V; otherwise the output voltage of the buck converter will drop too low and affect the transmitted waveform from the PA; the average current taken from the boost converter in this configuration is around 300mA.

The Iridium Core 9523N includes a total capacitance of 1680 μ F on the VBOOST rail to store charge. The voltage across the capacitors at the end of each transmit time-slot must not fall below 16.0V; otherwise the output voltage of the buck-boost converter will drop too low and affect the transmitted waveform from the PA; the average current taken from the boost converter in this configuration is around 300mA.

It is possible to produce VBOOST in other ways, particularly if the FA has a convenient supply rail that has high enough voltage and current capacity. Table 12 shows the permissible limits for any VBOOST supply.

Table 12: VBOOST Specification

Parameter	Value
Absolute maximum voltage (limited by capacitor rating)	35V
Maximum recommended voltage	32V
Minimum voltage when capacitors are charged	27V
Maximum current into VBOOST pins (limited by rating of inter-board connector) ⁵	1A
Maximum power taken by buck converter (during transmit time-slot)	30W

The maximum average power requirement over a 90ms period is 3.1W. The capacitors discharge to typically 15V on the Iridium Core 9523 and 21V on the Iridium Core 9523N during the transmit burst when operating at maximum power. A typical design would have a power limit of between 5 and 6 Watts (current approximately 0.25 Amp) so that the reservoir capacitors are replenished in approximately half the allowed time.

If the boost voltage at the start of the transmit burst is below the minimum (27V) then the capacitors may discharge to below 9.5V on the Iridium Core 9523 and 16.0V on the Iridium Core 9523N, in which case the transmitter power will reduce.

There is a residual VBAT current of about 70mA all the time that the Iridium Core 9523/9523N is switched on, even when not in a call. Periodically, the Iridium Core 9523/9523N will draw about 250mA from the VBAT rail for about 20ms, as it maintains synchronization with the signal from the satellites.

When an Iridium call is in progress, there are two peaks in the current drawn by the VBAT rail in each 90ms frame – one of about 300mA during the transmit time-slot and a slightly smaller one, 250mA, during the receive time-slot.

At the start of each of period when the receiver or transmitter is active a burst of current will be drawn, as the radio circuitry switches on. This current is caused by the charging of six 4.7µF capacitors on the outputs of internal voltage regulators⁶.

3.3 PCM Digital Audio

The Iridium Core 9523/9523N has two PCM digital audio ports, though only one of these can be in use at any time. The active port is selected using the AT+CAR command. This setup allows the FA board to provide two parallel audio paths and switch between them through software instead of hardware. The two ports have identical signals and timing, as shown in Figure 11. The PCM clock and sync signals are outputs from the Iridium Core 9523/9523N.

The PCM clock signal has a frequency of 2048 kHz with an accuracy of 1 ppm, but it is derived from an internal clock source by a fractional divider so each clock high period and low period is either 238.1 ns or 297.6 ns.

The PCM clock, sync and data signal outputs are all timed from the same internal clock and are skewed by less than 1 ns (at equal load).

⁵ It is recommended that supply overcurrent protection is provided by the partner application that incorporates the Iridium Core 9523/9523N.

⁶ This is only applicable to the Iridium Core 9523.

The PCM data input has set-up and hold time requirements of 30 ns with respect to the falling edge of the PCM clock signal.

The two PCM ports were originally intended to be connected to a voice source/sink via a codec (such as the Texas Instruments TLV320AIC1110) for analog audio and directly for digital audio, but there is no need to use them in this way.

Figure 11 - PCM waveform diagram

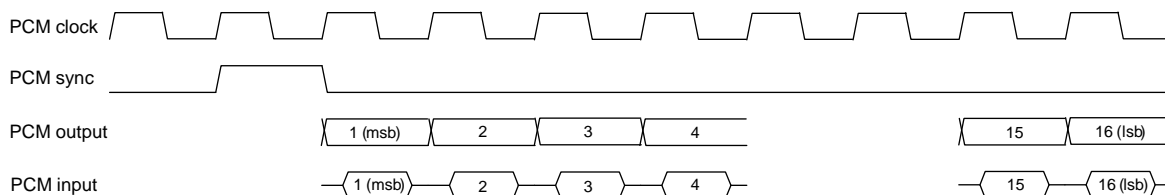

3.3.1 Port 1

Port 1 has the following signal pins:

Table 13: PCM Port 1 Signals

Signal function	Signal name
PCM clock output	CODEC_PCMCLK
PCM sync output	CODEC_PCMSYNC
PCM data output	CODEC_PCMIN
PCM data input	CODEC_PCMOUT

Note: the data signal names on Port 1 are defined from the point of view of an externally connected codec.

3.3.2 Port 2

Port 2 has the following signal pins:

Table 14: PCM Port 2 Signals

Signal function	Signal name
PCM clock output	UC_DACLK
PCM sync output	UC_DAFS
PCM data output	UC_DATX
PCM data input	UC_DARX

Note: the data signal names on Port 2 are defined from the point of view of the Iridium Core 9523/9523N.

3.3.3 11Hz Signal for Manufacturing and Regulatory Testing

An external 'frame tick' signal needs to be passed to the Iridium Core 9523/9523N during regulatory radio testing of the host system, and possibly also during manufacturing testing. This frame signal has a period of 90ms (11.1Hz) and is fed to the Iridium Core 9523/9523N using the CODEC_PCMOUT PCM data input.

The frame tick signal can have any mark-space ratio but must be externally synchronized to the Iridium Core 9523/9523N's internal clock. This is most easily achieved by double buffering the signal through two D-type latches clocked by CODEC_PCMCLK.

3.4 DPL port

The DPL port is a three-wire asynchronous serial port. It carries 8-bit, no parity data at 115,200 baud.

The DPL port enables peripherals such as handsets and SIM card readers to be interfaced to the Iridium Core 9523/9523N. The interface utilizes an Iridium proprietary communication bus not detailed in this document. Details can be made available after appropriate Non-Disclosure and/or License Agreements are executed.

The serial data signals use standard 3.3V signals with conventional polarity. If desired, an external RS232 level converter could be fitted to the FA board to extend range.

3.5 Data/Fax port

The asynchronous serial data/fax interface is comprised of eight standard RS232 data (8-bit, no parity), control, and status signals plus a ground level signal reference. This interface allows the FA to utilize the Iridium Core 9523/9523N's modem functionality via AT command control. With respect to this interface, the Iridium Core 9523/9523N behaves as a DCE (Data Communication Equipment), and the FA behaves as a DTE (Data Terminal Equipment).

The data/fax interface supports 3.3V / LVTTTL levels. If RS-232 voltage levels are needed, the FA must include an LVTTTL/RS-232 level shifter.

A 3-wire RS232 Data minimal interface may also be implemented; however the 9-wire interface offers better control and is the recommended implementation.

Autobaud is enabled by default. Autobaud will occur on the following characters: 'a', 'A', or CR (carriage return). Autobaud will also occur on the escape sequence character, provided this is an odd number character. Normally this is set to '+' in register S2.

See the ISU AT Command Reference for further information on the data/fax interface.

3.6 SIM interface

The Iridium Core 9523/9523N needs an external Iridium SIM card and socket to be connected to its SIM interface. The signals operate at 3.3V logic levels, so an external SIM level converter such as the ONSemiconductor NCN4555 must be connected between the Iridium Core 9523/9523N and the SIM connector/socket to allow 3V or 1.8V SIM cards to be used.

An external SIM card reader may also be interfaced as a peripheral to the Iridium Core 9523/9523N via the DPL interface. A SIM card in the external reader will take precedence over the SIM chip connected to the SIM interface when both are present.

3.7 GPIO Signals

There are four GPIO signals to the Iridium Core 9523/9523N, as described in this section.

3.7.1 Transmit power Control

The radiated power output from the Iridium transmitter can exceed SAR safety limits if the antenna is too close to the operator's body. An Iridium handset has a telescopic antenna to provide the necessary safe distance. The GPIO signals ANT_DET_PWR and FULL_POWER_EN are used to control the transmit power in conjunction with an antenna position-detector switch.

The Iridium Core 9523/9523N polls the position-detector switch by providing a 3.3V output on ANT_DET_PWR in order to provide power to the antenna position sensing circuitry. When ANT_DET_PWR is high, the position sensing circuit must take FULL_POWER_EN high to enable full transmit power.

3.7.2 External GPS Receiver Switch

If the Iridium Core 9523/9523N is used near a GPS receiver, it is possible that the input circuitry of the GPS receiver could be damaged by the output power of the Iridium transmitter, especially if the two devices share a single antenna. The Iridium Core 9523/9523N has a GPIO signal, TX_ACTIVE, which is high whenever the Iridium transmitter is active and this could be used to control a switch on the input of the GPS receiver.

The TX_ACTIVE signal goes high 610us before the start of a transmit burst (ie. full power), and goes low 220us after the end of the burst. There is also 100us of power ramp-up before the burst and 100us of ramp-down after the burst.

3.7.3 Modem/Handset Mode Select Signal

A further GPIO signal, LBT_HSTB, is used to indicate whether the Iridium Core 9523/9523N should operate as though it is mounted in a handset or a modem device. It should be pulled to 3.3V for normal modem operation, or 0V for handset mode. The major differences are:

- Data/Fax port is operational in modem mode and disabled in handset mode.
- Background radio scanning for active radio channels is less intensive in handset mode, because power consumption is a more important issue for a battery-powered handset.

4 RF Interface

This section describes the physical characteristics of the RF connector and specifications of the RF Interface.

4.1 RF Connector Type

The RF connector on the Iridium Core 9523/9523N is an I-PEX part number 20314-001E-01, from their MHF product range. When mating to the Iridium Core 9523/9523N RF connector, use a suitable plug from the MHF (20308) or MHFII (20312) ranges.

Additional information can be found at: <http://www.i-pex.com>

Note that the RF connector on the Iridium Core 9523/9523N is not mounted directly to the FA board along with the user interface connector. It must be attached to the FA board through a coaxial cable.

Note that for safety reasons, the RF connector on the Iridium Core 9523/9523N should not be directly connected to an external antenna cable or cable distribution system. Paragraph 7.3 of EN60950-1:2006 safety standard requires that users are protected against high voltages that might appear on these cables. This can be achieved either by inserting a high-voltage isolating capacitor in series with the signal or by grounding the shield of the coaxial cable. The I-PEX connector has limited voltage capacity; therefore protection needs to be provided on the FA board. Developers are encouraged to review the EN60950-1:2006 standard for additional details.

4.1.1 Antenna Characteristics

The Iridium Core 9523/9523N should be connected to a certified Iridium-band antenna with the following antenna connector characteristics as described in Table 15.

Table 15: Antenna Characteristics

Parameter	Value
Impedance	50 Ohms nominal
Gain (maximum)	3 dBi
Polarization	RHCP
VSWR (maximum operational)	1.5 : 1

Existing qualified Iridium antennas may be used. (i.e. antennas designed and certified for the 9601, 9602, 9522, 9522A and 9522B) in conjunction with suitable protection circuitry.

4.2 RF Interface Specifications

The RF interface requirements for the Iridium Core 9523/9523N are summarized in Table 16 below.

Table 16: General RF Parameters

Parameter	Value
Frequency Range	1616 MHz to 1626.5 MHz
Duplexing Method	TDD (Time Domain Duplex)
Input/Output Impedance	50Ω
Multiplexing Method	TDMA/FDMA

4.3 Radio Characteristics

Table 17 contains radio characteristics of the Iridium Core 9523/9523N.

Table 17: Radio Characteristics

Parameter	Value
Average Power during a transmit slot (max)	7 W
Average Power during a frame (typical)	0.6 W
Receiver sensitivity (Typical level at connector)	-118 dBm
Max Cable loss permitted (Note 1)	3 dB
Link Margin – Downlink (Note 2)	12 dB
Link Margin – Uplink (Note 2)	12 dB

Note 1: Cable losses should be minimized. The total implementation loss for an antenna, connectors, cable, lightning arrestor and any other RF component between the Iridium Core 9523/9523N and the antenna should not exceed 3 dB. Implementation loss higher than this will affect the Iridium link performance and quality of service. Solutions with a loss higher than 3 dB will not meet the requirements of Iridium Solution Certification.

Note 2: Link Margins are given assuming a free-space propagation model.

4.4 S-meter Performance

The numbers reported over the AT command interface indicate the signal strength of the ring channel. Care should be taken when using the S-meter readings for comparisons between devices. Of particular note are the following:

1. There is a 0.5 dB tolerance on calibrating the S-meter.
2. Each bar represents a 2 dB increment.
3. Multiple ring channels can be present at the same time so units can lock to different signals.
4. If the reading is near the decision threshold it would be easy to see a 1 bar difference.

5 AT Interface

The Iridium Core 9523/9523N is configured and operated through the use of AT commands. See the ISU AT Command Reference for the full set of AT commands and responses. For differences in AT command support between Iridium Core 9523/9523N software releases, see the relevant software release notes, which are made available to authorized Iridium VARs and VAMs on the Iridium Developer Extranet. It is the responsibility of Product Developers to check compatibility of applications software with the AT Commands on all Iridium Core 9523/9523N software versions used for both development and commercial deployments.