



STB1132-25

Module Specification

Ver1.0.0

©2016-2017 ITON Technology Corp.

本檔案是商業機密，未經事先同意，不得向第三方廠商透露。此處提供的資訊被認為是可靠的，但生產測試可能不包括所有參數的測試。中易騰達科技股份有限公司保留在沒有通知的情況下隨時更改資訊的權利。

This document contains information that is proprietary to ITON Technology Corp. This document is commercially confidential and must NOT be disclosed to third parties without prior consent. The information provided herein is believed to be reliable. But production testing may not include testing of all parameters. ITON Technology Corp. reserves the right to change information at any time without notification.

Contents

Version:.....	3
1. Overview.....	4
1.1 Brief.....	4
1.2 Features.....	4
1.3 Application.....	4
2. Hardware System.....	5
2.1 Function block.....	5
2.2 PIN assignment.....	6
2.3 PIN description.....	6
2.4 Schematic diagram.....	7
2.5 Electronic parameter.....	8
2.5.1 Basic parameter.....	8
2.5.2 Maximum parameter.....	9
2.5.3 Working Voltage.....	9
2.5.4 Working Current.....	9
2.5.5 External Crystal.....	10
2.5.6 TX parameter.....	10
2.6 Dimensions.....	11
2.6.1 Mechanical dimensions.....	11
2.6.2 Layout reference dimensions.....	12
3. Process parameters.....	13
3.1 Recommended temperature curve.....	13
4. Package information.....	13
5. Please be noticed following information and instructions should be placed in the end-user' s operating manual.....	14
6. FCC Certification Requirement:.....	16

Version:

Data	Version		Edit
2017-02-15	V0.01	Draft	Kain
2017-03-07	V0.02	Revised 2.2 PIN assignment 2.3 PIN description 2.4 Schematic diagram	Kain
2017-3-20	V0.03	Revised DIO12 description	Kain
2017-4-13	V1.00	Released version	Kain

1. Overview

1.1 Brief

Bluetooth module STB1132-25 base on ST newest LE4.1 chipset BlueNRG1, establish a bidirectional data transfer channel through UART interface between mobile phone and client's MCU. According to the content of commands list, Client's MCU may send the corresponding commands to set the Bluetooth module into different condition, or send or receive data on GATT layer, Bluetooth module's status also can be read through commands.

1.2 Features

- Support LE4.1
- Support OTA upgrade
- Support UART upgrade
- Stable and reliable performance
- Support UART command
- Up to 8dBm TX power

1.3 Application

- Bluetooth Printer/Scanner
- Mobile payment
- Wireless health & fitness equipment
- Wireless toys
- Smart Household Electric Appliances

2. Hardware System

2.1 Function block

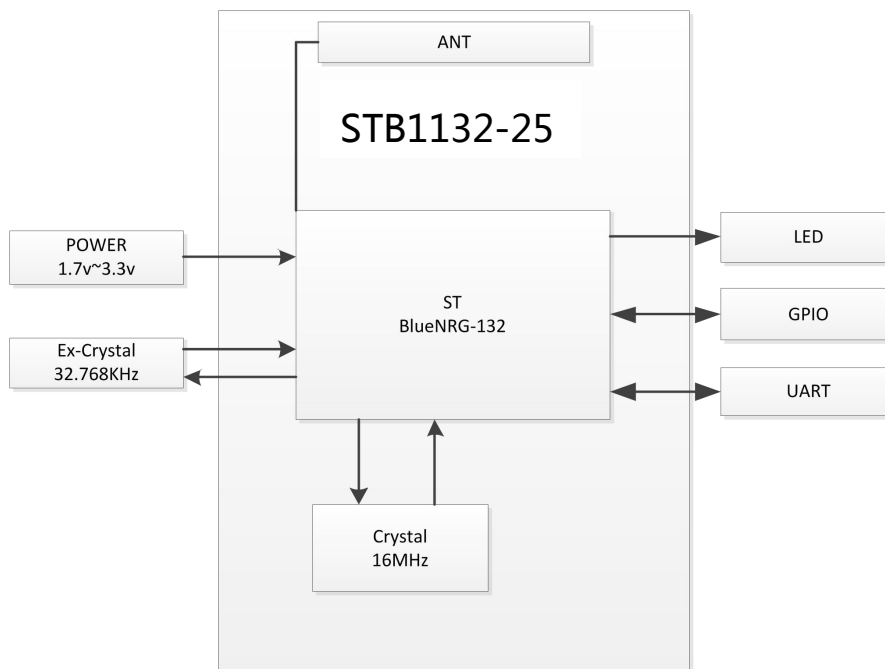

2.2 PIN assignment

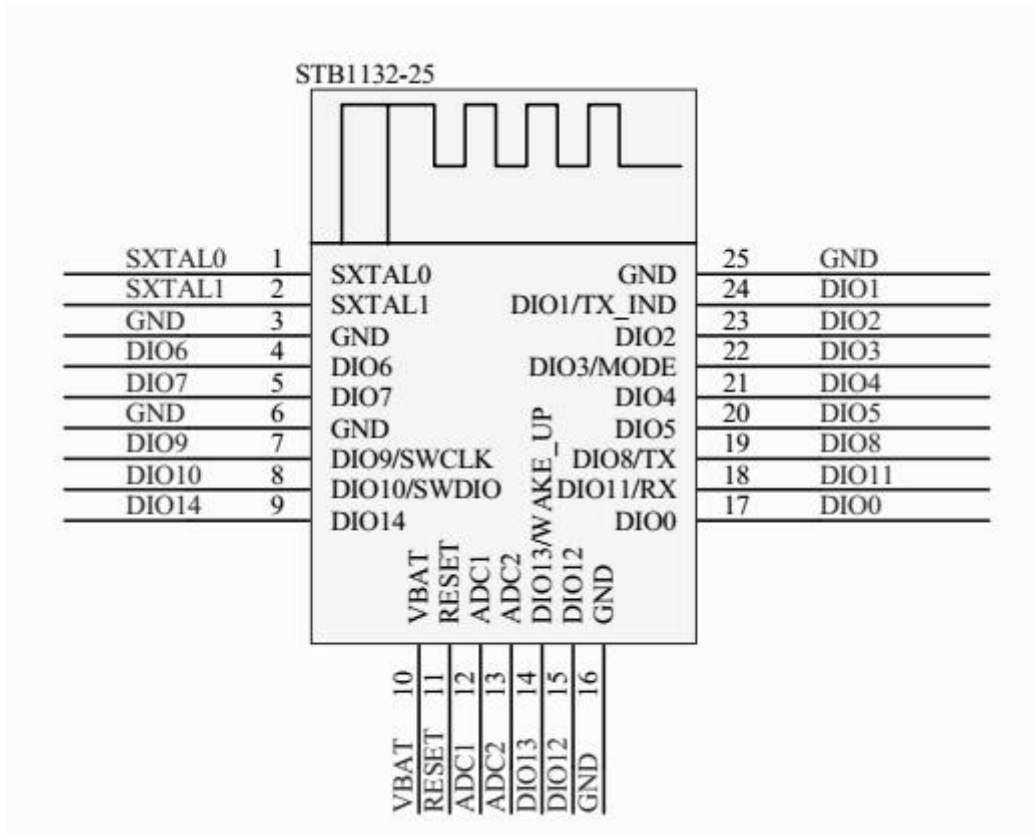

2.3 PIN description

No.	Name	Description	Mark
1	SXTAL0	32.768KHz Xtal	
2	SXTAL1	32.768KHz Xtal	
3	GND	POWER	
4	DIO6	I/O	
5	DIO7	I/O	
6	GND	POWER	
7	SWCLK/DIO9	Software download PIN	Software download PIN, suggest reserve on PCB
8	SWDIO/DIO10	Software download PIN	Software download PIN, suggest reserve on PCB
9	DIO14	I/O	
10	VBAT	POWER	
11	REST	Module hardware reset	
12	ADC1	I/O	

13	ADC2	I/O	
14	DIO13/Wake-up	When module in sleep, lower level this PIN to wake up module	Pull down duration≥50ms
15	DIO12	I/O	
16	GND	POWER	
17	DIO0	I/O	
18	UART_RX	UART RX PIN	
19	UART_TX	UART TX PIN	
20	DIO4	I/O	
21	DIO5	I/O	
22	DIO3/Mode_N	Mode select PIN H: Data mode L: Command mode	Default: H
23	DIO2	I/O	
24	DIO1/UART_TX_ IND	Time delay control PIN for sending data from module to MCU	Default Close Can use command to set up the time delay
25	GND	POWER	

2.4 Schematic diagram

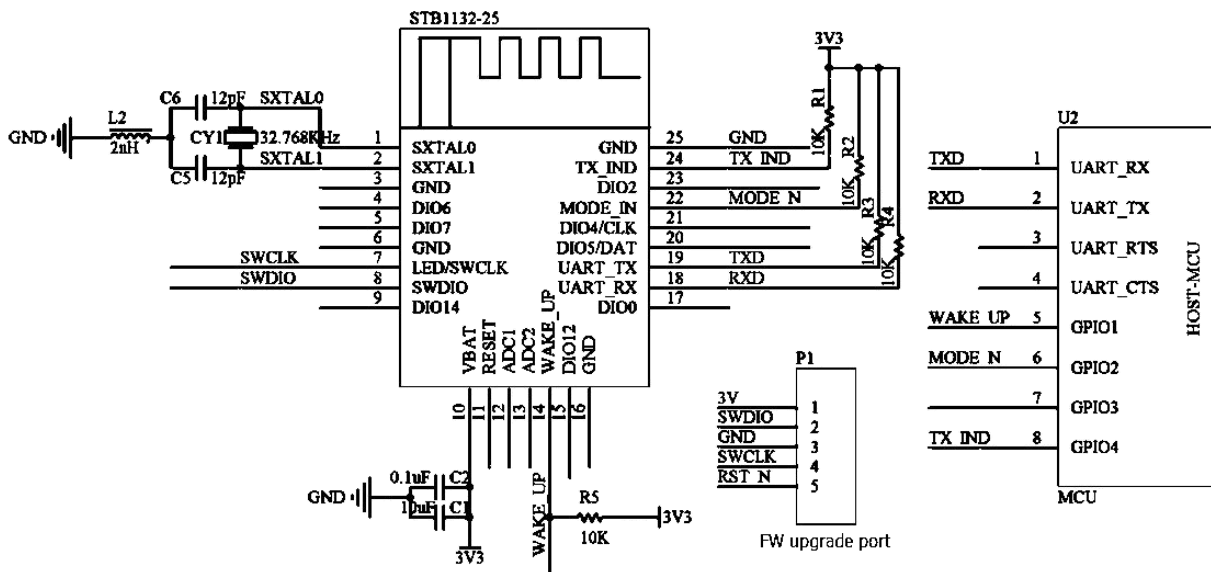

Note:

- 1) 32.768KHz may save 2uA power consumption in Sleep mode, do not connect if not necessary.
- 2) Wake-up PIN is used to wake-up the module when it enter low power mode, please connect to MCU GPIO through pull-up resistor R5. If this MCU GPIO with Pull-up function, then may connect to wake-up Pin directly.
- 3) Mode-IN PIN is used to switch module between pure data mode & command mode, please connect to MCU GPIO through Pull-up resistor R2. If this MCU GPIO with Pull-up function, then may connect to Mode-in PIN directly.
- 4) TX-IND PIN is used to control the time delay before Module send data to MCU. Please connect to MCU GPIO through Pull-up resistor R1.
- 5) UART_RX/UART_TX, need add pull-up resistor accordingly, suggest to reserve.
- 6) P1 is the FW download port, please reserve if the PCB space is enough.

2.5 Electronic parameter

2.5.1 Basic parameter

Item	Range
Working frequency band	2400MHz~2500MHz
Protocol specification	BT4.1
Max TX power	+8dBm
RX sensitivity	-88dBm
Work voltage	1.7V~3.6V
Interface	UART
Baud rate	4800~921600
Size	20.5mm(L) x14 mm(W) x 2.5mm(H)

2.5.2 Maximum parameter

Item	Min.	Max.	Unit
VCC voltage	-0.3	3.9	V
Working temperature	-20	75	°C
Storage temperature	-30	85	°C
Working range	TBD.	TBD.	

a note : VCC=3.0v, data flow 2Kbyte/s, under open environment

2.5.3 Working Voltage

Item	Min.	Typ.	Max.	Unit
VCC Voltage	1.7	3.0	3.6	V

2.5.4 Working Current

Test condition: Vcc=3.0v@ , Ta=25°C

Mode	Current (Avg.)	Unit	Notes
Sleep Mode	5	uA	
Standby mode(Discoverable)	40	uA	No advertising
	57	uA	LE Reduced Power advertising interval = 300ms
BLE Connected	400	uA	No data, connection interval = 20ms
	79	uA	No data, connection interval = 500ms
	2.39	mA	20byte/s, connection interval = 20ms
	2.92	mA	2Kbyte/s, connection interval = 20ms

2.5.5 External Crystal

SB1132-20 may be connected with external 32.768KHz crystal, this may save about 2uA power consumption in sleep mode. Crystal request as below:

Item	Parameter	Min.	Typ.	Max.	Unit
f_{NOM}	Nominal frequency		32.768		KHz
f_{TOL}	Frequency tolerance			±50	ppm
ESR	Equivalent series resistance			90	kΩ
PD	Drive level			0.1	μW

2.5.6 TX parameter

Item	Min.	Typ.	Max.	Unit
Maximum RF transmit power		8		dBm
LE Sensitivity		-85		dBm

2.6 Dimensions

2.6.1 Mechanical dimensions

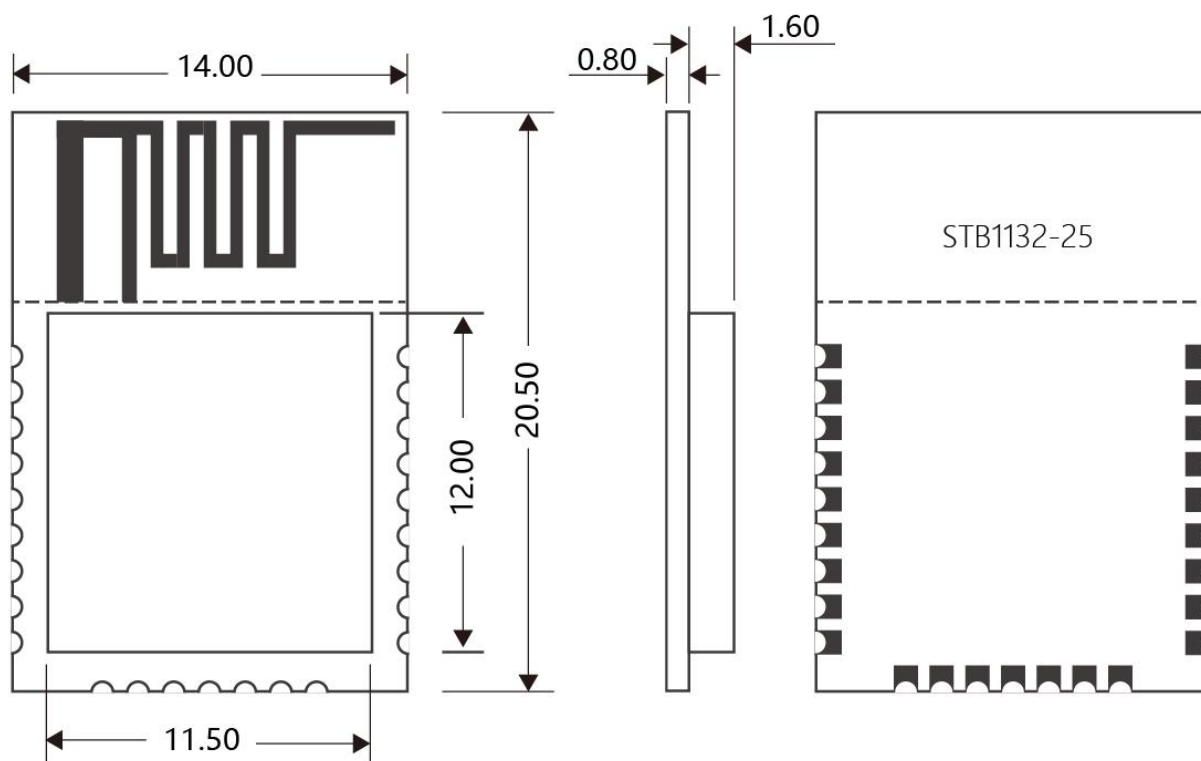

2.6.2 Layout reference dimensions

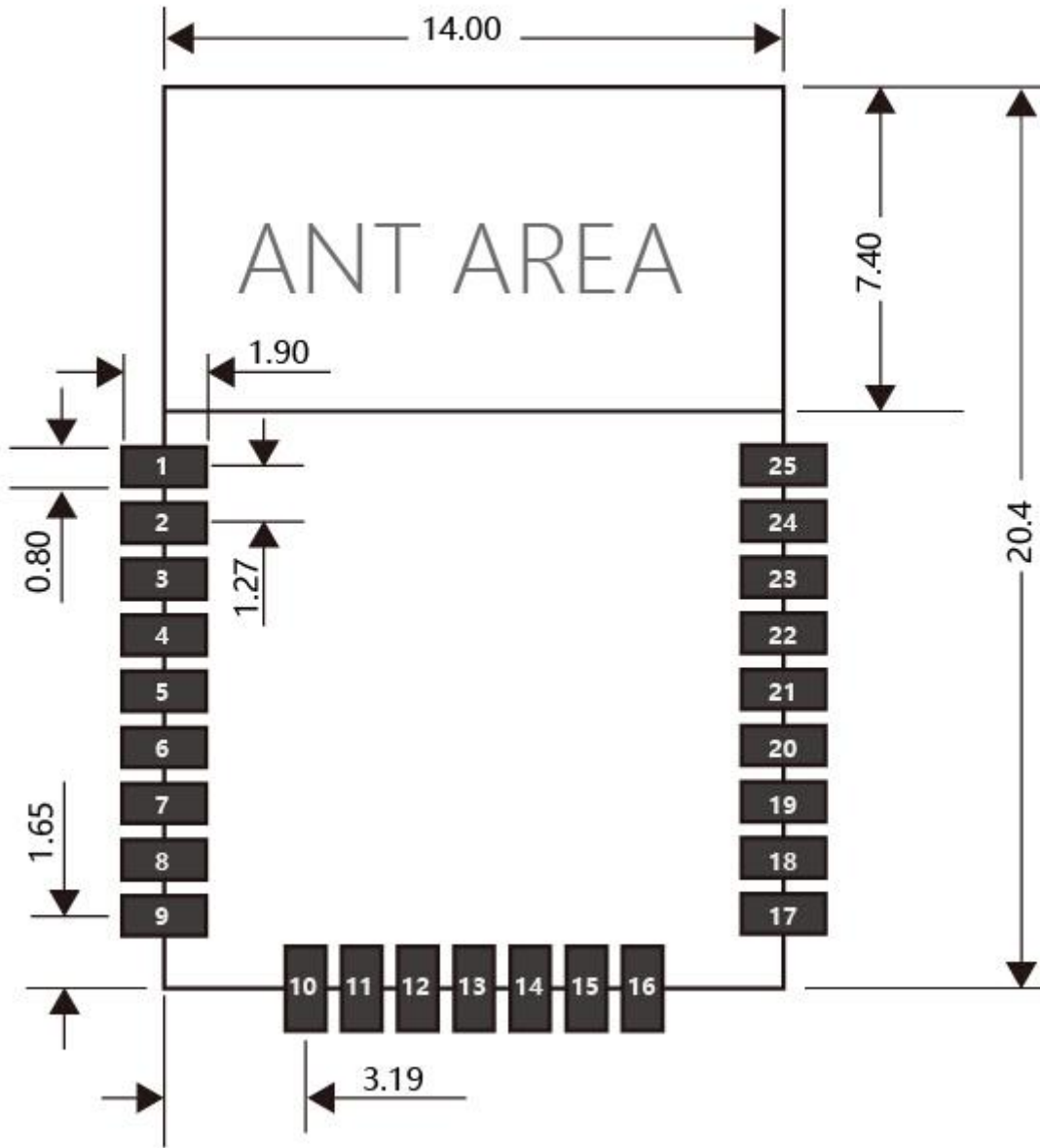

Layout note:

The ANT area please keep clearance, do not routing & copper.

Filter CAP please place close to module.

Non strong interference line under module.

3. Process parameters

3.1 Recommended temperature curve

Referred to IPC/JEDEC standard.

Peak Temperature : <250°C

Number of Times : ≤2 times

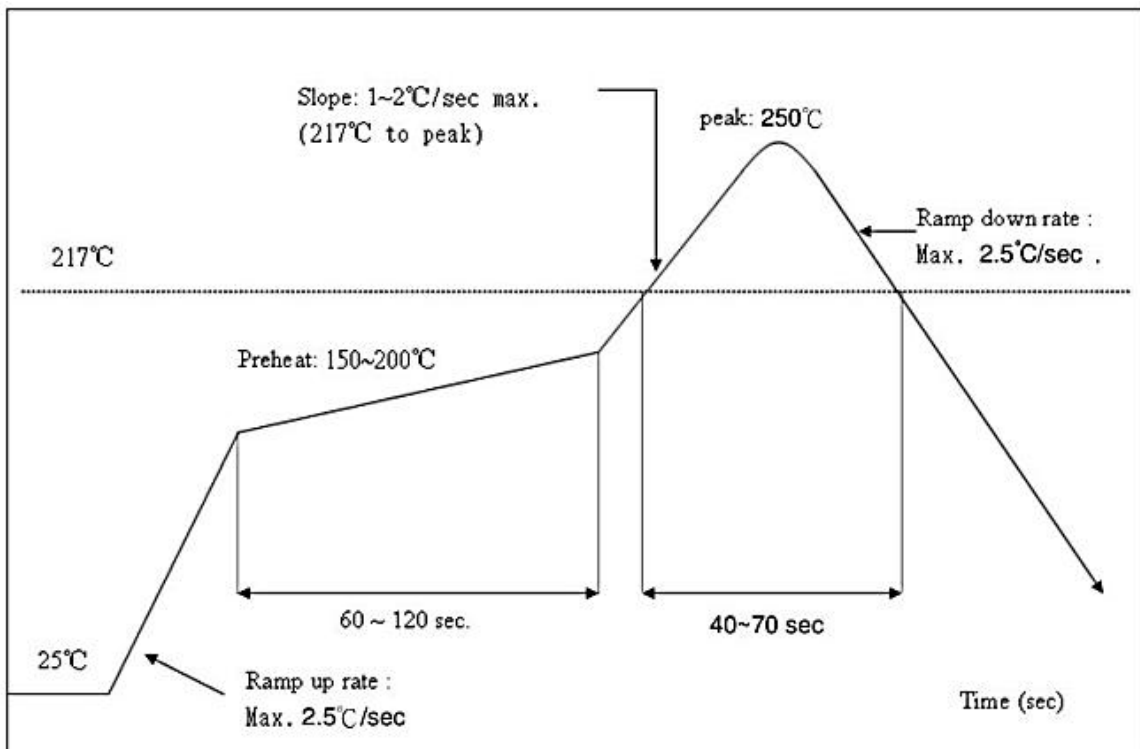

4. Package information

TBD

5. Please be noticed following information and instructions should be placed in the end-user' s operating manual

The MODEL STB1132 has been granted as limited modular approval for mobile applications. MODEL STB1132 must be installed in the designated host as specified in this manual.

1. Separate approval is required for all other operating configurations, including portable configurations with respect to 2.1093 and different antenna configurations.
2. The MODEL STB1132 and its antenna must not be co-located or operating in conjunction with any other transmitter or antenna within a host device. This equipment complies with FCC RF radiation exposure limits set forth for an uncontrolled environment.
3. A label must be affixed to the outside of the end product into which the MODEL STB1132 module is incorporated, with a statement similar to the following: For MODEL STB1132: This device contains FCC ID: 2AJ22STB1132.
4. The module shall be in non-detachable construction protection into the finished products, so that the end-user has to destroy the module while remove or install it.
5. This module is to be installed only in mobile or fixed applications. According to FCC part 2.1091(b) definition of mobile and fixed devices is:.

Mobile device:

A mobile device is defined as a transmitting device designed to be used in other than fixed locations and to generally be used in such a way that a separation distance of at least 20 centimeters is normally maintained between the transmitter's radiating structure(s) and the body of the user or nearby persons. In this context, the term "fixed location" means that the device is physically secured at one location and is not able to be easily moved to another location.

Portable device:

For purposes of this section, a portable device is defined as a transmitting device designed to be used so that the radiating structure(s) of the device is/are within 20 centimeters of the body of the user.

6. Separate approval is required for all other operating configurations, including portable configurations with respect to FCC Part 2.1093 and different antenna configurations.

7. A certified modular has the option to use a permanently affixed label, or an electronic label. For a permanently affixed label, the module must be labelled with an FCC ID: 2AJ22STB1132. The OEM manual must provide clear instructions explaining to the OEM the labelling requirements, options and OEM user manual instructions that are required

For a host using a this FCC certified modular with a standard fixed label, if (1) the module's FCC ID is not visible when installed in the host, or (2) if the host is marketed so that end users do not have straightforward commonly used methods for access to remove the module so that the FCC ID of the module is visible; then an additional permanent label referring to the enclosed module:

“Contains Transmitter Module FCC ID: 2AJ22STB1132” or “Contains FCC ID: 2AJ22STB1132” must be used. The host OEM user manual must also contain clear instructions on how end users can find and/or access the module and the FCC ID.

8. Host product is required to comply with all applicable FCC equipment authorizations regulations, requirements and equipment functions not associated with the transmitter module portion. compliance must be demonstrated to regulations for other transmitter components within the host product; to requirements for unintentional radiators (Part 15B). To ensure compliance with all non-transmitter functions the host manufacturer is responsible for ensuring compliance with the module(s) installed and fully operational. If a host was previously authorized as an unintentional radiator under the Declaration of Conformity procedure without a transmitter certified module and a module is added, the host manufacturer is responsible for ensuring that the after the module is installed and operational the host continues to be compliant with the Part 15B unintentional radiator requirements. Since this may depend on the details of how the module is integrated with the host, we suggest the host device to recertify part 15B to ensure complete compliance with FCC requirement: Part 2 Subpart J Equipment Authorization Procedures , KDB784748 D01 v07, and KDB 997198 about importation of radio frequency devices into the United States.

6. FCC Certification Requirement:

The end product with an embedded - MODEL STB1132 may also need to pass the FCC Part 15 unintentional emission testing requirements and be properly authorized per FCC Part 15.

Note: If this module is intended for use in a portable device, you are responsible for separate approval to satisfy the SAR requirements of FCC Part 2.1093.

This device complies with Part 15 of the FCC Rules.

Operation is subject to the following two conditions:

- (1) this device may not cause harmful interference, and
- (2) this device must accept any interference received, including interference that may cause undesired operation.

Changes or modifications made to this equipment not expressly approved by iTon Technology Corp. may void the FCC authorization to operate this equipment.