

**Natural Gas Solutions**  
**100G Installation Guide**  
Revision A

*Putting knowledge to work.*

## Identification

100G Installation Guide -- DRAFT  
Part number: PUB-0200-001 Revision A 10/06  
ERT Part Numbers: ERG-aaaa-bbb, CCCC-ddd, etc.

## Copyright

© 2006 Itron, Inc. All rights reserved.

Your company has the right to reproduce this contract document, provided that such reproduction shall be subject to the same use and disclosure restrictions contained in the Confidentiality and Non-Disclosure paragraphs in the Sales Contract.

## Applicable Patents

U.S. Patent Numbers: XXXXXXXXXXXXXXXXXXXX XXXXXXXXXXXXXXXXXXXX XXXXXXXXXXXXXXXXXXXX???

Canadian Patent Numbers: XXXXXXXXXXX XXXXXXXXXXX XXXXXXXXXXX?????????

## Transportation Classification

Itron classifies and ships model 100G ERT modules as a non-hazardous material. The proper shipping name is **Lithium Batteries contain in Equipment, Class 9, UN3091, Packing Group II.**

The Federal Aviation Administration prohibits operating transmitters and receivers on all commercial aircraft. When powered, the 100G ERT module is considered an operating transmitter and receiver and cannot be shipped by air.

## Compliance Statement

This equipment has been tested and found to comply with the limits for a Class B digital device, pursuant to Part 15 of the FCC Rules. These limits are designed to provide reasonable protection against harmful interference in a residential installation. This equipment generates, uses, and can radiate radio frequency energy and, if not installed and used in accordance with the instructions, may cause harmful interference to radio communications. However, there is no guarantee that interference will not occur in a particular installation.

If this equipment does cause harmful interference to radio or television reception, which can be determined by turning the equipment off and on, the user is encouraged to try to correct the interference by one or more of the following measures:

- Reorient or relocate the receiving antenna.
- Increase the separation between the equipment and receiver.
- Connect the equipment into an outlet on a circuit different from that to which the receiver is connected.
- Consult the dealer or an experienced radio or TV technician for help.

This device complies with Subpart C of Part 15 of FCC Rules. Operation of this device is subject to the following two conditions:

- This device may not cause harmful interference.
- This device must accept any interference that may cause undesirable operation.

This device must be permanently mounted such that it retains a distance of 20 centimeters (7.9 inches) from all persons in order to comply with FCC RF exposure levels.

## Modification and Repairs

To ensure FCC compliance and system performance, this device and antenna shall not be changed or modified without the expressed approval of Itron. Any unauthorized modification will void the user's authority to operate the equipment.

## Meter Installation/Removal

In the event of malfunction, all repairs should be performed by Itron. It is the responsibility of users requiring service to report the need for service to Itron.

## Related Documents

EndPoint-Link ERT Programming Guide (TDC-ibd-ibd)

## Trademark Notice

ERT and Itron are both registered trademarks of Itron, Inc. All other product names and logos in this documentation are used for identification purposes only and may be trademarks or registered trademarks of their respective companies.

## Suggestions

If you have comments or suggestions on how we may improve this documentation, send them to [TechnicalCommunicationsManager@itron.com](mailto:TechnicalCommunicationsManager@itron.com).

If you have questions or comments about this application, contact Itron Technical Support:

**Itron, Inc.**

- Mail: Itron, Inc. 2401 North State Street, Waseca, MN 56093
- E-mail: [support@itron.com](mailto:support@itron.com)
- Phone: 1 800 392 3185; Fax: 507 837 4451

# Table of Contents

---

- Chapter 1 Getting Started ..... 1**
  - Transmission Modes ..... 1
  - Specifications ..... 1
  - Meter Compatibility List ..... 2
  
- Chapter 2 American Meter Installation ..... 5**
  - Installation Prerequisites ..... 5
    - Materials Supplied By Itron ..... 5
    - Materials Supplied By You ..... 5
      - Replacement Screws ..... 6
  - Preinstallation Preparations ..... 6
  - Installing the 100G on an American Meter ..... 6
    - Remove the Existing Index ..... 6
    - Assemble the ERT Module ..... 9
    - Program the ERT Module ..... 13
    - Attach the ERT Module to the Meter ..... 15
  
- Chapter 3 Sensus Meter Installation ..... 19**
  - Introduction ..... 19
  - Installation Prerequisites ..... 19
    - Materials Supplied By Itron ..... 19
    - Materials Supplied by You ..... 19
      - Replacement Screws ..... 19
  - Preinstallation Preparations ..... 20
  - Installing the 100G on a Sensus Meter ..... 20
    - Remove the Existing Index ..... 20
    - Assemble the ERT Module ..... 22
    - Program the ERT ..... 24
    - Attach the ERT to the Meter ..... 25



## Getting Started

---

The 100G is Itron's latest high-powered gas encoder-receiver-transmitter (ERT) module.

ERTs are meter-installed devices that transmit meter data using radio communications. That information may be received by a reading device that is within transmission distance, meaning that multiple devices may receive data from a single endpoint. Itron's 100G ERT is a high-powered device with a wide transmission distance.

This installation guide shows you how to install the 100G ERT module on meters from a variety of manufacturers. To ensure you have a meter that is compatible with the 100G ERT module, please see the [Meter Compatibility List](#) on page 2.

## Transmission Modes

Once installed, the 100G ERT module has two standard available transmission modes:

- **Fixed Network Mode** In this mode, a 100G ERT module transmits a high-powered RF message every 60 seconds.
- **Mobile and HandHeld Mode** In this mode, a 100G ERT module transmits a medium-powered RF message every 15 seconds.

An FCC license is not required to read 100G ERT modules.

## Specifications

The functional and operational specifications for the 100G are listed below.

<b>Functional Specifications</b>	<b>Description</b>
<b>Power Source</b>	"A" cell lithium battery
<b>Tamper Detection</b>	Tilt tamper and magnetic tamper
<b>FCC Compliance</b>	Part 15 certified
<b>Industry Canada Compliance</b>	RSS-210 certified
<b>Measurement Canada Approval</b>	Yes
<b>Intrinsically Safe per</b>	Factory Mutual and UL Class I, Division 1, Groups C and D
<b>Product Identification</b>	Numeric and barcoded ERT module type and serial number
<b>Construction Materials</b>	Gray polycarbonate back plate with Santoprene® gasket; clear polycarbonate front cover; encapsulated electronics

<b>Operational Specifications</b>	<b>Description</b>
<b>Operating Temperatures</b>	-40° to 158° F (-40° to +70° C)
<b>Operating Humidity</b>	5 to 95percent relative humidity
<b>Program Frequency</b>	908 MHz
<b>Transmit Frequency</b>	Spread spectrum 908 to 924 MHz ISM band
<b>Data Integrity</b>	Verified in every data message

## Meter Compatibility List

The following meters are compatible with the 100G. Due to continuous research, product improvements, and enhancements, Itron reserves the right to change this list at any time.

To ensure you have the latest Meter Compatibility list available, contact your Itron representative.

<b>Mfgr.</b>	<b>Model</b>	<b>Desc.</b>	<b>Class</b>	<b>Comments</b>	<b>ERT Type</b>	<b>ERT Part No.</b>
American/ Canadian	W75AL		Residential	Aluminum case Meters Only	100G	ERG-5000-001
American/ Canadian	AL-175		Residential	Aluminum case meters only	100G	ERG-5000-001
American/ Canadian	AC-175		Residential	Aluminum case meters only	100G	ERG-5000-001
American/ Canadian	AT-175		Residential	Aluminum case meters only	100G	ERG-5000-001
American/ Canadian	ALC-175		Residential	Aluminum case meters only	100G	ERG-5000-001
American/ Canadian	AT-210		Residential	Aluminum case meters only	100G	ERG-5000-001
American/ Canadian	AL-225	Canada only	Residential	Aluminum case meters only	100G	ERG-5000-001
American/ Canadian	AL-250		Residential	Aluminum case meters only	100G	ERG-5000-001
American/ Canadian	AR-250		Residential	Aluminum case meters only	100G	ERG-5000-001
American/ Canadian	AC-250		Residential	Aluminum case meters only	100G	ERG-5000-001
American/ Canadian	AT-250		Residential	Aluminum case meters only	100G	ERG-5000-001
American/ Canadian	AM-250		Residential	Aluminum case meters only	100G	ERG-5000-001
American/ Canadian	AL-310		Residential	Aluminum case meters only	100G	ERG-5000-001

American/ Canadian	AL-350		Residential	Aluminum case meters only	100G	ERG-5000-001
American/ Canadian	AT-350		Residential	Aluminum case meters only	100G	ERG-5000-001
American/ Canadian	AL-425		Residential	Aluminum case meters only	100G	ERG-5000-001
American/ Canadian	AC-630		Residential	Aluminum case meters only	100G	ERG-5000-001
American/ Canadian	5B 225		Residential	Aluminum case	100G	ERG-5000-001
Sensus/Invensys/ Equimeter/ Rockwell	R-175	11 Tooth	Residential	Compatible with 2 foot drive index; 1 foot drive has 24 teeth	100G	ERG-5000-002
Sensus/Invensys/ Equimeter/ Rockwell	R-200	11 Tooth	Residential		100G	ERG-5000-002
Sensus/Invensys/ Equimeter/ Rockwell	RT-200	11 Tooth	Residential		100G	ERG-5000-002
Sensus/Invensys/ Equimeter/ Rockwell	RT-230	11 Tooth	Residential		100G	ERG-5000-002
Sensus/Invensys/ Equimeter/ Rockwell	R-275	11 Tooth	Residential		100G	ERG-5000-002
Sensus/Invensys/ Equimeter/ Rockwell	RT-275	11 Tooth	Residential		100G	ERG-5000-002
Sensus/Invensys/ Equimeter/ Rockwell	R-315	11 Tooth	Residential		100G	ERG-5000-002
Sensus/Invensys/ Equimeter/ Rockwell	250	11 Tooth	Residential		100G	ERG-5000-002
Sensus/Invensys/ Equimeter/ Rockwell	310	11 Tooth	Residential		100G	ERG-5000-002
Sensus/Invensys/ Equimeter/ Rockwell	S-110	11 Tooth	Residential		100G	ERG-5000-002
Sensus/Invensys/ Equimeter/ Rockwell	S-200	11 Tooth	Residential		100G	ERG-5000-002
Sensus/Invensys/ Equimeter/ Rockwell	175-S	11 Tooth	Residential		100G	ERG-5000-002
Sensus/Invensys/ Equimeter/ Rockwell	RT-100	18 Tooth	Residential		100G	ERG-5000-004
Sensus/Invensys/ Equimeter/ Rockwell	S-190	11 Tooth	Residential		100G	ERG-5000-002

Sensus/ Invensys/ Equimeter/ Rockwell	S-120	11 Tooth	Residential		100G	ERG-5000-002
Sensus/Invensys/ Equimeter/ Rockwell	T-120	11 Tooth	Residential		100G	ERG-5000-002
Sensus/Invensys/ Equimeter/ Rockwell	T-110	11 Tooth	Residential		100G	ERG-5000-002
Sensus/Invensys/ Equimeter/ Rockwell	R-415	18 Tooth	Residential		100G	ERG-5000-004
Sensus/Invensys/ Equimeter/ Rockwell	RT-360	18 Tooth	Residential		100G	ERG-5000-004
Sensus/Invensys/ Equimeter/ Rockwell	MR8 (R-275 Metric)	16 Tooth	Residential		100G	ERG-5000-003
Sensus/Invensys/ Equimeter/ Rockwell	MR12 (R-415 Metric)	16 Tooth	Residential		100G	ERG-5000-003



## American Meter Installation

---

This chapter shows you how to install a 100G gas ERT module on an American meter.

Before installing the 100G ERT module, verify that you have:

- A compatible meter. See the the [Meter Compatibility List](#) on page 2 for more information.
- A compatible index. Itron 100G gas ERT modules can be used with standard dial and direct read (odometer) indexes on American Meters.
- The list of materials defined under [Installation Prerequisites](#) on page 5.

### Installation Prerequisites

The following items are required to install Itron's 100G gas ERT.

#### Materials Supplied By Itron

The following items are supplied by Itron.

- 100G gas ERT modules
- Tamper plugs

#### Materials Supplied By You

You must supply the following items to successfully install the 100G gas ERT on the American Meters listed in the Meter Compatibility above.

- **Small and medium flat-blade screwdrivers** Used to remove and tighten index and index-cover screws.
- **Side-cutting plier/wire snips** Used for cutting wire seals, if necessary.
- **Small putty knife** Used to remove all traces of old gaskets from the meter.
- **Meter seals, wire seals, and seal press** Used to secure the meter from tampering, if necessary.
- **11/32-inch nut driver or other blunt tool** Used to securely seat new tamper plugs over screw holes.
- **FC200SR unit with EndPoint-Link or EndPoint-Link Pro software** Used to program and check ERT assembly.
- **Replacement screws** Used to mount ERT assembly to meter and index to ERT assembly backlates; see [Replacement Screws](#) on page 6 for more information).

## Replacement Screws

Replacement screws used in this procedure must be slotted, zinc-plated, steel machine screws. Sizing options are shown below.

- Use 1/4 - 20 x 5/8-inch slotted, Fillister head screws for mounting 100G ERT module assemblies on meters.
- Use 8 - 32 x 3/16-inch slotted, round head screws for mounting indexes on 100G ERT module backplates.

## Preinstallation Preparations

Before installing the 100G gas ERT module on a meter, verify that:

- All ERTs are type 100G modules for American Meter Company gas meters.
- The model numbers of all meters on which the 100G modules will be installed are included in the [Meter Compatibility](#) see "Meter Compatibility List" on page 2 list.

## Installing the 100G on an American Meter

There are four major steps to installing the 100G gas ERT on an American Meter:

- Remove the Existing Index
- Assemble the ERT Module
- Program the ERT Module
- Attach the ERT Module to the Meter

These procedures are described in the following sections.



**NOTE** Be sure to properly dispose of all unused screws, old index covers, gaskets, and other left-over materials. Do not leave any materials on customer premises.

### Remove the Existing Index

The first major step when installing a 100G gas ERT on an American meter is to remove the existing index from the meter.

#### *To Remove the Existing Index*

1. Remove any tamper seals from the meter.

2. Detach the index cover from the meter by removing the four screws holding it in place.



3. Examine the index cover screws you just removed. Verify that they are 5/8-inch long and are not corroded.
  - If the screws are 5/8-inch long, and are not corroded, keep them for later use.
  - If the screws are an incorrect length or are corroded, dispose of them properly. Use 1/4 - 20 x 5/8-inch screws as described in [Replacement Screws](#) on page 6 instead.



**TIP** You can use the index cover you just removed as a temporary storage location for screws.

4. Unscrew one index mounting screw completely.

Hold one hand beneath the index to catch the screw when it falls out of the index assembly. If it does not fall out by itself, be sure to remove it.

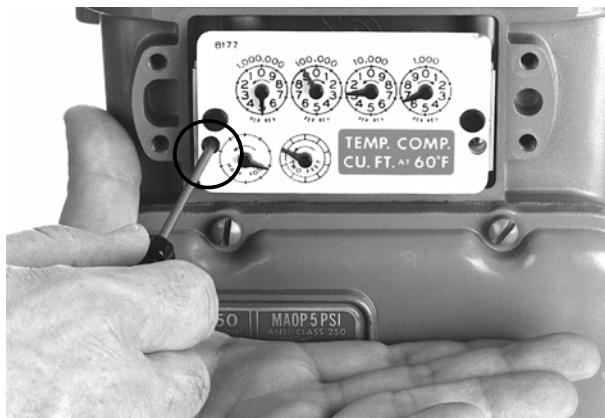

5. Unscrew the other index mounting screw.

While removing this screw, pull the index away from the meter to keep its backplate (1) against the back of the screwhead (2). This prevents the screw from falling out prematurely.

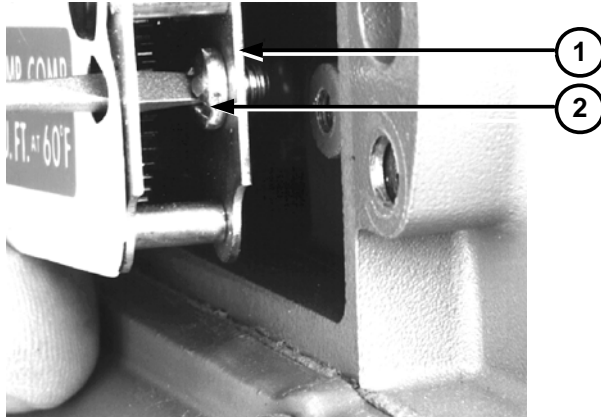

6. Remove the screw from the index once it is completely free of its hole.
7. Set the index aside for the moment. Place it where it will not be damaged; get filled with dirt, rain, or snow; or fall to the ground or floor. The index will be used later in this procedure.
8. Examine the index screws you just removed. Verify that they are 3/16-inch long and are not corroded.
  - If the screws are 3/16-inch long and are not corroded, keep them for later use.
  - If the screws are an incorrect length or are corroded, dispose of them properly. Use 8 - 32 x 3/16-inch screws as described in [Replacement Screws](#) on page 6 instead.
9. Use a putty knife or similar object to completely remove the old index gasket from the meter (if applicable). All traces of the gasket must be removed before the ERT can be installed.

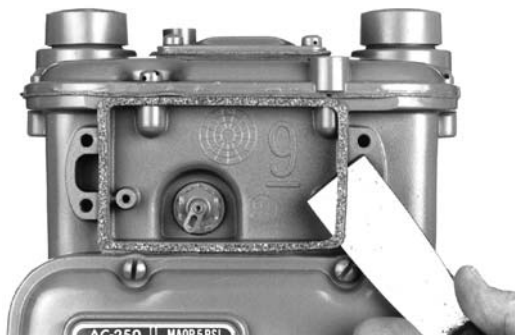

## Assemble the ERT Module

When installing a 100G gas ERT, the next major step is to create the ERT module assembly by combining the ERT backplate and cover with the meter index. Follow the procedure below to do so.

### To Assemble the ERT Module

1. Obtain a new 100G ERT and index cover.
2. Separate the ERT module backplate from the cover.

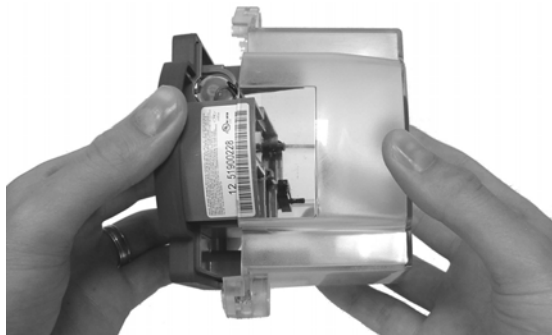

3. Set the new ERT index cover aside for the moment. Place it where it will not be damaged; get filled with dirt, rain, or snow; or fall to the ground or floor. The ERT index cover will be used later in this procedure.



**IMPORTANT** Before continuing with the installation, note the following information about American Meter indexes:

- Index wrigglers on one-foot meters have drive slots.

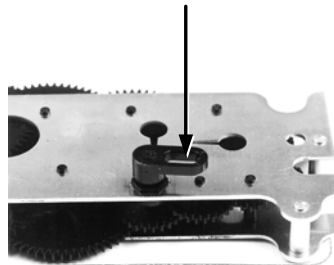

- Index wrigglers on two-foot meters have drive posts.

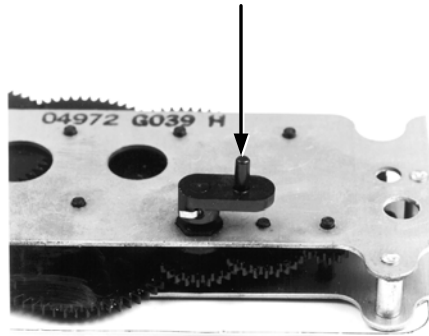

- An index may have mounting screw holes.

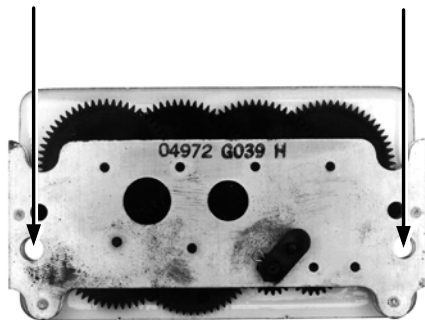

- An index may have mounting screw slots.

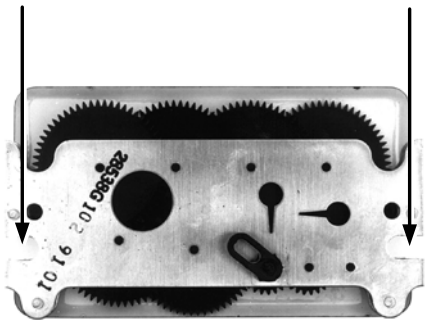

If the index has mounting screw *slots*, skip steps 4 and 5 below. Continue with step 6.

If the index has mounting screw *holes*, perform steps 4 and 5 below, and then skip steps 6 and 7.

4. If the index has mounting screw *holes*, place an index mounting screw (1) in the right-hand mounting screw hole (2). Use one 8 - 32 3/16-inch screw for this step (you can use an original mounting screw if it was the correct size and not corroded; otherwise, use the correct size replacement screw).

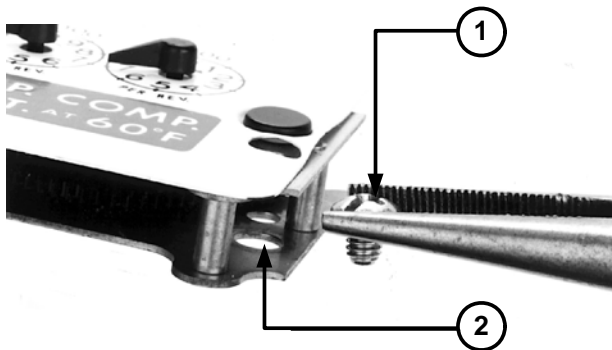

5. Attach the screw to the ERT backplate's right-hand index mounting post just far enough to hold the screw and end of the index in place.

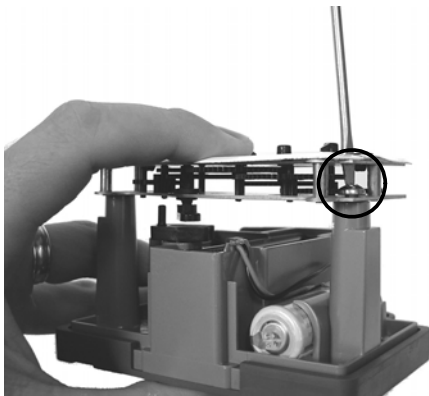

6. If the index has mounting screw *slots*, screw an index mounting screw (1) one to two turns into the ERT backplate's right-hand index mounting post (2). Use one 8 - 32 3/16-inch screw for this step (you can use an original mounting screw if it was the correct size and not corroded; otherwise, use the correct size replacement screw).

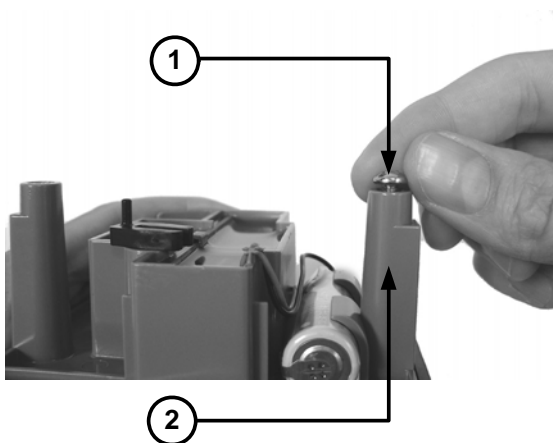

7. Place the index mounting screw slot under the screw head. *Do not* tighten the screw yet.

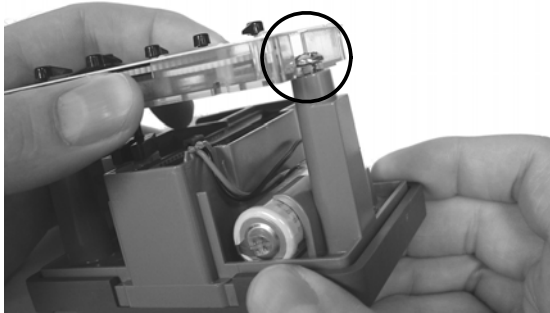

8. Attach the wiggler to the index and backplate.
  - If the index wiggler has a drive slot (1), place the backplate wiggler's drive post (2) in the index wiggler's drive slot.

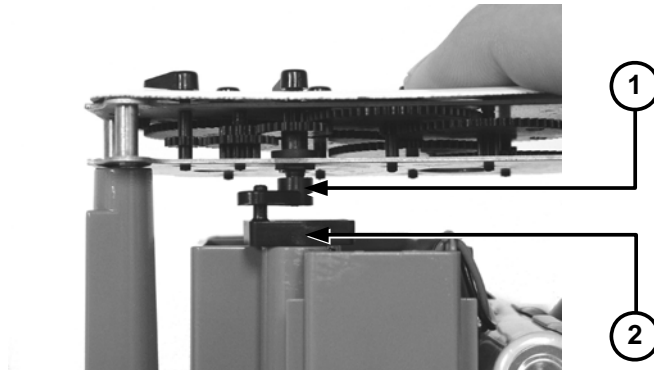

- If the index wiggler has a drive post (1), place the index wiggler's drive post in the backplate wiggler's drive slot (2).

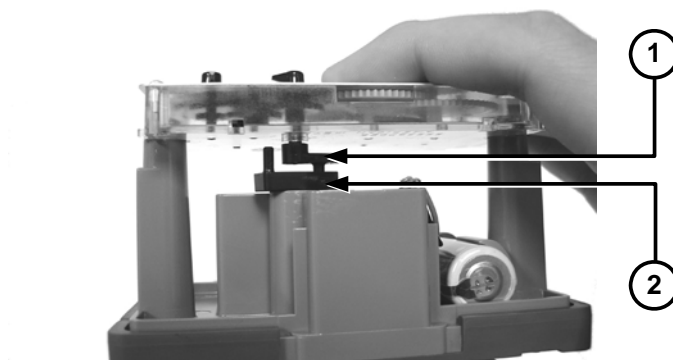



9. Install and tighten the left-hand index mounting screw (for indexes with either mounting screw slots or holes). Use one 8 - 32 3/16-inch screw for this step (you can use an original mounting screw if it was the correct size and not corroded; otherwise, use the correct size replacement screw).

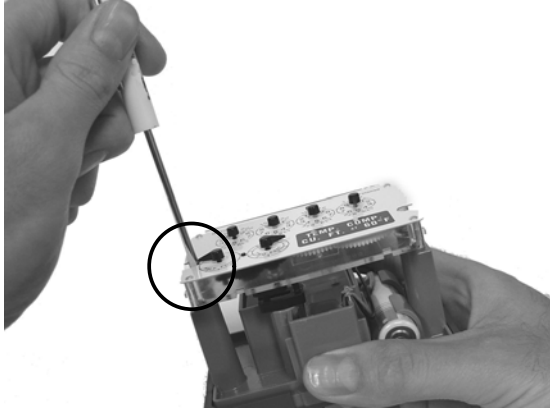

10. Tighten the right-hand index mounting screw.
11. Slide the ERT cover (1) over the index and backplate, making sure the ERT label (2) is visible through the window.

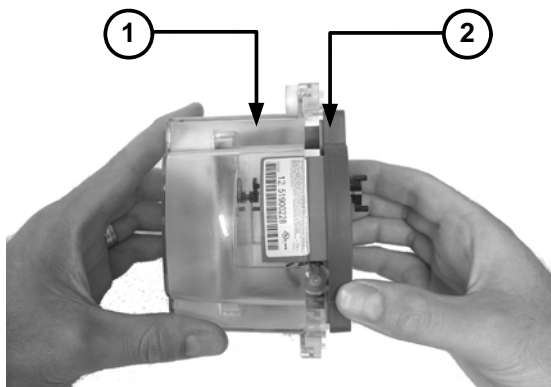

Next, program the ERT module.

## Program the ERT Module

Once the ERT module has been assembled, the ERT must be programmed using the FC200/SR with EndPoint-Link software. See the *EndPoint-Link ERT Programming Guide (TDC-tbd-xxx)* for more information.



**IMPORTANT** You must perform the following programming procedure for the ERT module to function properly.

When programming the ERT module, you must take note of the drive rate shown on the index of American meters. Examples of 1-foot (1) and 2-foot (2) drive rates are shown below. Be sure to program the ERT based on the indicated drive rate.

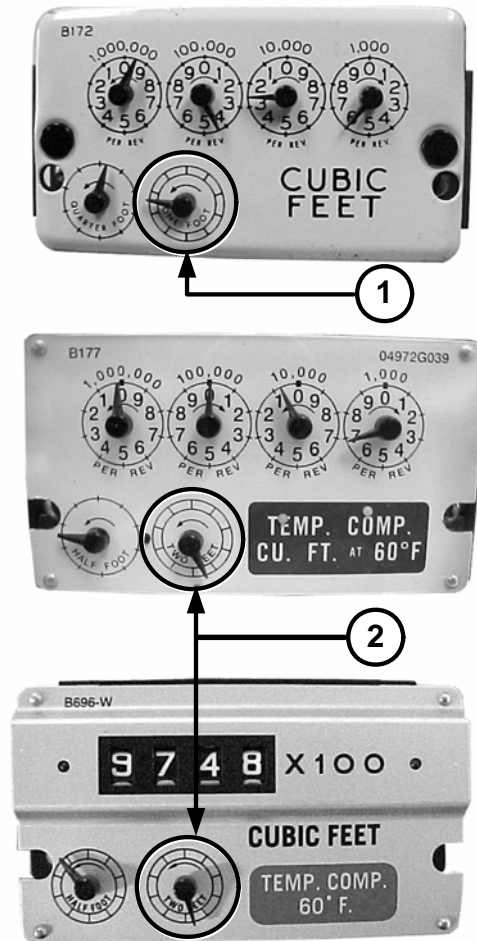

### To Program the ERT Module

1. Using the FC200/SR, program the reading of the index that was on the meter into the ERT module assembly. Be sure to hold the FC200/SR unit by the battery pack and within a few inches of the ERT during programming and reading; this will ensure proper communication between unit and the ERT.

During programming, the 100G ERT module is programmed to the *nearest 100 cubic feet*; the last two digits (the tens and units) are programmed as zeros (0). Once programming is complete, however, the ERT module assembly can be read to the nearest cubic foot.

2. Slowly turn the ERT module drive wiggler two turns in the direction indicated on the index drive rate. This lets you verify the ERT module is counting properly after assembly.



**IMPORTANT** Do not turn the drive wiggler faster than *one turn per second*.

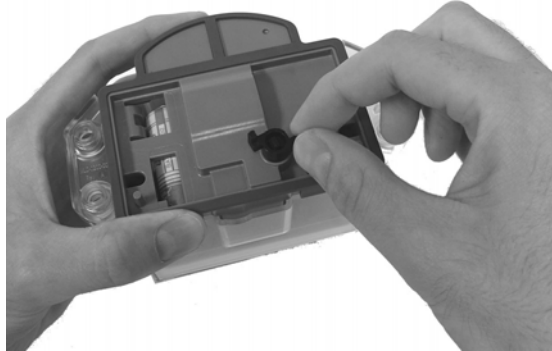

3. Read the ERT module assembly using the FC200SR. Consult the *EndPoint-Link ERT Programming Guide (TDC-tbd-tbd)* or other applicable instructions for details on how to read an ERT.
  - If this reading is higher than the one you programmed in step 1 above, the ERT module assembly is counting correctly.
  - If the ERT module assembly reading is *not* higher than what was programmed in step 1, replace the ERT module with a new one.

## Attach the ERT Module to the Meter

After the ERT has been programmed and is reading correctly, it must be attached to the meter. Follow the steps below to do this.

### *To Attach the ERT to the Meter*

1. **5B 225 Meters Only** If you are installing the ERT on a 5B 225 aluminum meter, cut 1/16-inch off each post of the ERT wiggler to prevent it from rubbing on the face of the nut that holds the wiggler in place. If you are not installing on a 5B 225 meter, continue to step 2 below.

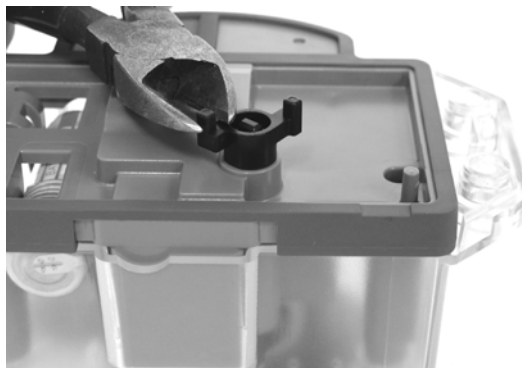

2. Set the wriggler to the desired position for mounting the ERT module assembly to the meter.
  - For One-Foot Meters: Align the ERT module assembly wriggler with the meter drive post (as shown below). Make sure the ERT wriggler is perpendicular to the meter drive post.

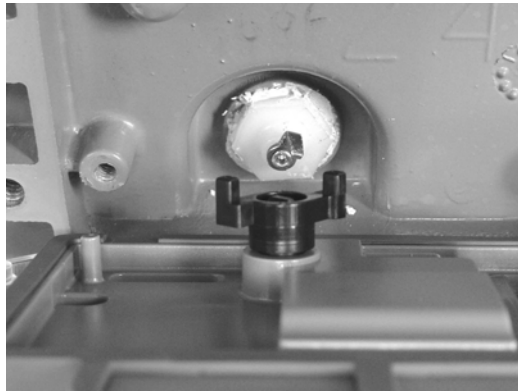

- For Two-Foot Meters: Align the ERT module assembly wriggler with the meter slot (as shown below). Make sure the ERT wriggler is perpendicular to the meter slot.

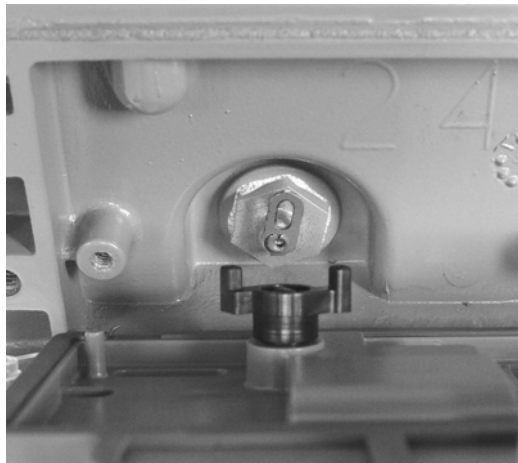

3. Gently place the ERT module assembly on the meter. Align the four screw holes on the ERT module assembly with the holes on the meter.

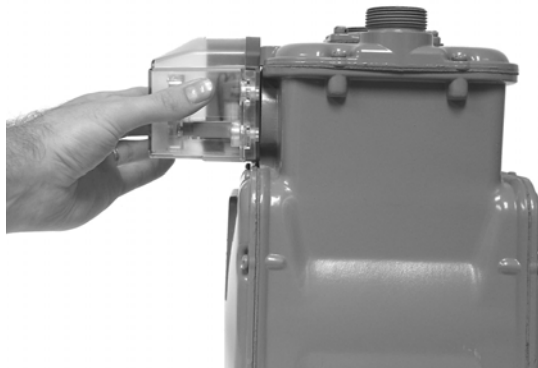

4. Install and tighten all ERT module assembly mounting screws, working in a diagonal pattern as shown below. Tighten the mounting screws to 15 to 20 inch-pounds of torque. Use the 1/4 - 20 x 5/8-inch screws for this step (you can use the original mounting screws if they were the correct size and not corroded; otherwise, use the correct size [Replacement Screws](#) on page 6).

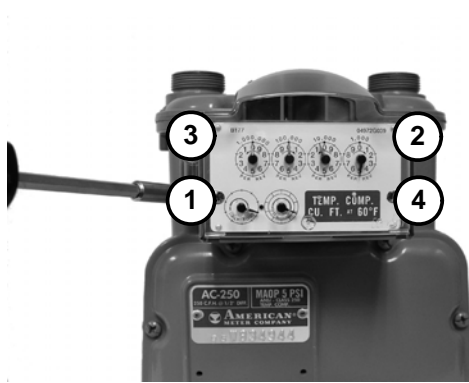

5. Place a new tamper seal over two of the mounting screws as shown below.

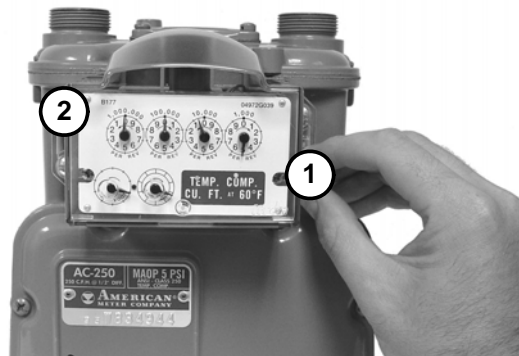

6. Press the new tamper seals into place using the 11/32-inch nut driver (or another similar blunt tool).

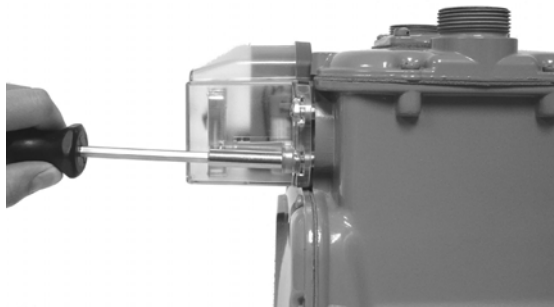

7. Complete any necessary paperwork. Make sure no excess material is left on the customer premises; dispose of it properly.

The ERT is now installed on the meter.



## Sensus Meter Installation

---

### Introduction

This chapter shows you how to install a 100G gas ERT on a compatible Sensus meter.



**Sensus** meters are also known by the following names: **Invensys**, **Equimeter**, and **Rockwell**. For consistency, all of these meter types will be referred to as Sensus meters for this installation procedure.

### Installation Prerequisites

#### Materials Supplied By Itron

The following items are supplied by Itron.

- 100G gas ERT modules
- Tamper plugs

#### Materials Supplied by You

You must supply the following items to successfully install the 100G gas ERT on the Sensus meters listed in the [Meter Compatibility List](#) on page 2.

- Small and medium flat-blade screwdrivers (used for index and index-cover screws)
- Side-cutting plier (used for cutting wire seals, if necessary)
- Small putty knife (to remove old gaskets)
- Meter seals, wire seals, and seal press (if necessary)
- 11/32-inch nut driver or other blunt tool (to securely seat new tamper plugs)
- ReadOne Pro unit (used to program and check ERT assembly)

Replacement screws (used to mount ERT assembly to meter and index to ERT assembly backlates; see [Replacement Screws](#) on page 19 for more information).

#### Replacement Screws

Replacement screws used in this procedure must be slotted, zinc-plated, steel machine screws. Sizing options are shown below.

For mounting 100G ERT module assemblies on meters:

- 10 - 24 x5/8-inch slotted, Fillister head

For mounting indexes on 100G ERT module backplates:

- 6 - 32 x 5/8-inch slotted, round head

## Preinstallation Preparations

Before installing the 100G gas ERT module on a meter, verify that:

- All ERTs are type 100G modules for Sensus gas meters.
- The model numbers of all meters on which the 100G modules will be installed are included in the [Meter Compatibility List](#) on page 2.

## Installing the 100G on a Sensus Meter

There are three major steps to installing the 100G gas ERT on a Sensus meter:

- Remove the Existing Index
- Assemble the ERT Module
- Program the ERT
- Attach the ERT to the Meter

These procedures are described in the following sections.



Be sure to properly dispose of all unused screws, old index covers, gaskets, and other left-over materials. Do not leave any materials on customer premises.

### Remove the Existing Index

The first major step when installing a 100G gas ERT on a Sensus meter is to remove the existing index from the meter.

#### ***To Remove the Existing Index***

1. Remove any tamper seals from the meter.



- Detach the index cover from the meter by removing the four screws holding it in place.

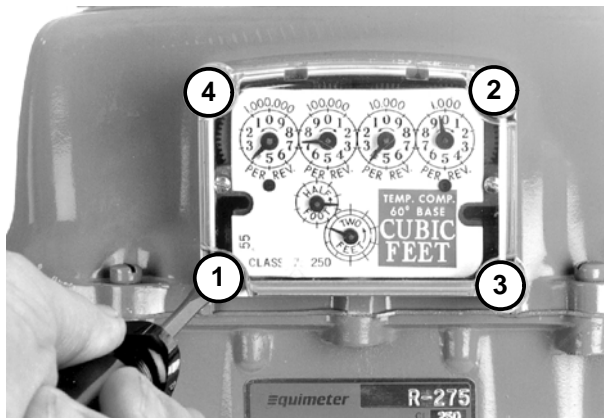

- Examine the index cover screws you just removed. Verify that they are 5/8-inch long and are not corroded.
  - If the screws are 5/8-inch long and are not corroded, keep them for later use.
  - If they are an incorrect length or are corroded, dispose of them properly. Use 10 - 24 x 5/8-inch screws as described in [Replacement Screws](#) on page 19 instead.



**TIP** You can use the index cover you just removed as a temporary storage location for screws.

- Unscrew one index mounting screw completely.

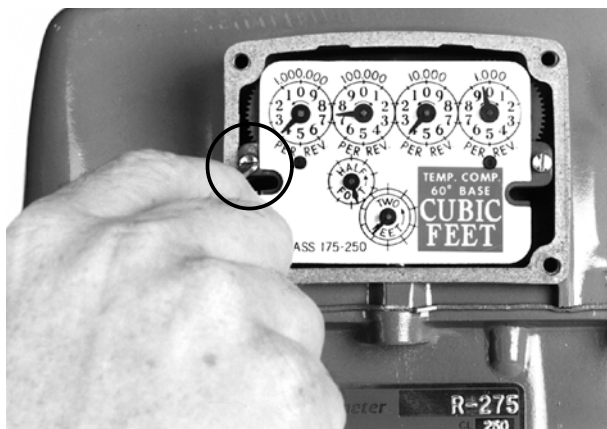

- Remove the other index mounting screw.
- Set the index aside for the moment. Place it where it will not be damaged; get filled with dirt, rain or snow; or fall to the ground or floor. The index will be used later in this procedure.
- Examine the index screws you just removed. Verify that they are 5/8-inch long and are not corroded.

- If the screws are 5/8-inch long and are not corroded, keep them for later use.
  - If the screws are an incorrect length or are corroded, dispose of them properly. Use 6 -32 x 5/8-inch screws as described in [Replacement Screws](#) on page 19 instead.
8. Use a putty knife or similar object to completely remove the old index gasket from the meter (if applicable). All traces of the gasket must be removed before the ERT can be installed.

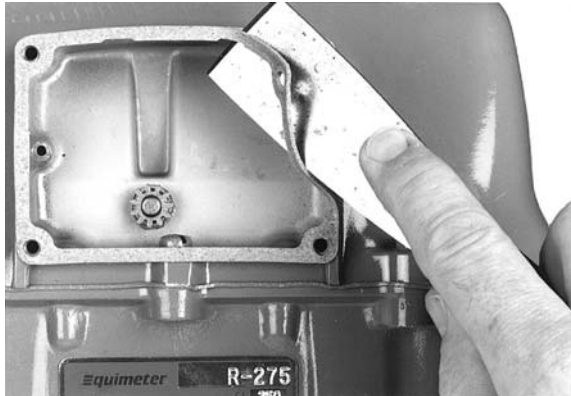

## Assemble the ERT Module

When installing a 100G gas ERT, the next major step is to create the ERT module assembly by combining the ERT backplate and cover with the meter index. Follow the procedure below to do so.

### *To Assemble the ERT*

1. Obtain a new 100G ERT and index cover.
2. Separate the ERT module backplate from the cover.
3. Place the index drive gear (1) in the backplate wiggler gear cup (2) of the ERT (please note that the following example uses an 11-tooth drive gear; your index may be slightly different).

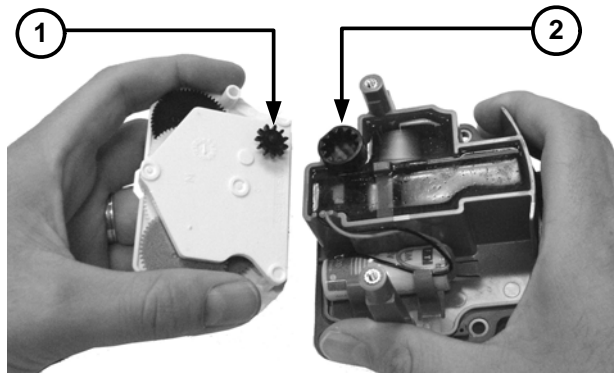

Once properly installed, the index drive gear and backplate wiggler cup should look similar to the following example.

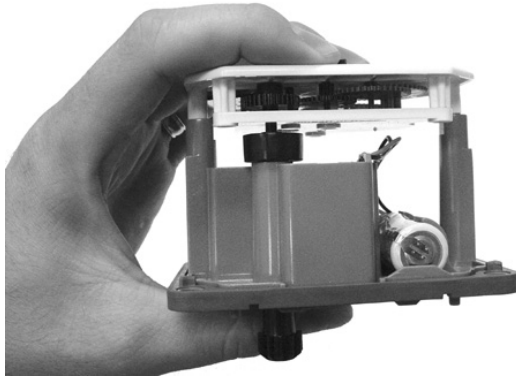

4. Attach the right-hand mounting screw to the index and meter, just far enough to hold the index in place. Use one 6 - 32 x 5/8-inch screw for this step (you can use an original mounting screw if it was the correct size and not corroded; otherwise, use the correct size [Replacement Screw](#) see "Replacement Screws" on page 19).

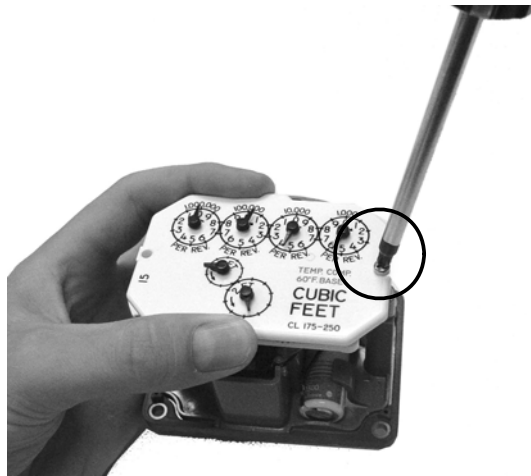

5. Install and tighten the left-hand index mounting screw.

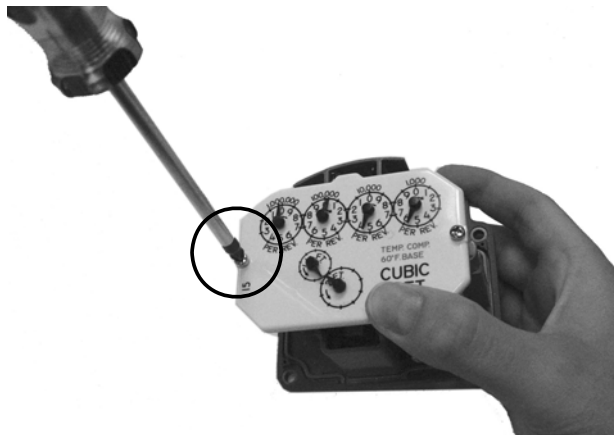

6. Tighten the right-hand index mounting screw completely.

7. Slide the ERT cover over the index and backplate.
8. Verify that the cover is installed correctly; the cover's clear window should be over the backplate label.



Once combined, the ERT backplate, meter index, and ERT cover create an "ERT Module Assembly."

Next, program the ERT module.

## Program the ERT

Once the ERT module has been assembled, the ERT must be programmed using the FC200/SR with EndPoint-Link software. See the *EndPoint-Link ERT Programming Guide (TDC-tbd-xxx)* for more information.



**IMPORTANT** You must perform the following programming procedure for the ERT module to function properly.

When programming the ERT module, you must take note of the drive rate shown on the index of Sensus meters. Sensus meters have a 2-foot drive rate, as indicated in the example below (1).

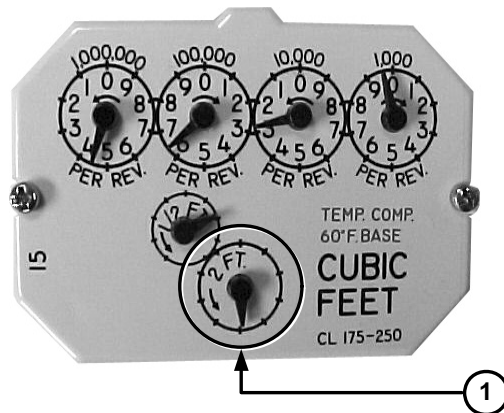

### To Program the ERT Module

1. Using the FC200/SR, program the reading of the index that was on the meter into the ERT module assembly. Be sure to hold the FC200/SR unit by the battery pack and within a few inches of the ERT during programming and reading; this will ensure proper communication between unit and the ERT.

During programming, the 100G ERT module is programmed to the *nearest 100 cubic feet*; the last two digits (the tens and units) are programmed as zeros (0). Once programming is complete, however, the ERT module assembly can be read to the nearest cubic foot.

2. Slowly turn the ERT module drive wriggler two turns in the direction indicated on the index drive rate. This lets you verify the ERT module is counting properly after assembly.



**IMPORTANT** Do not turn the drive wriggler faster than *one turn per second*.

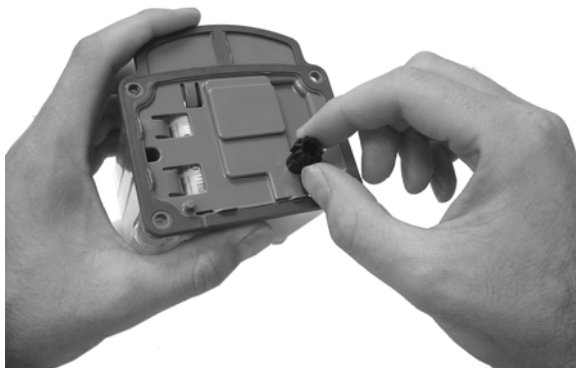

3. Read the ERT module assembly using the FC200SR. Consult the *EndPoint-Link ERT Programming Guide (TDC-tbd-tbd)* or other applicable instructions for details on how to read an ERT.
  - If this reading is higher than the one you programmed in step 1 above, the ERT module assembly is counting correctly.
  - If the ERT module assembly reading is *not* higher than what was programmed in step 1, replace the ERT module with a new one.

## Attach the ERT to the Meter

After the ERT has been programmed and is reading correctly, it must be attached to the meter. Follow the steps below to do this.

**To Attach the ERT to the Meter**

1. Gently place the ERT module assembly against the front of the meter as shown. Make sure all four mounting screw holes in the ERT module assembly line up with the corresponding holes on the meter.



2. Insert the top-right cover mounting screw. Tighten the screw just enough to hold the ERT module assembly in place. Use the 10 - 24 5/8-inch screws for this and the following step (you can use the original mounting screws if they were the correct size and not corroded; otherwise, use the correct size as described in [Replacement Screws](#) on page 19).



3. Install and tighten the remaining three mounting screws. Tighten the mounting screws to 15 to 20 inch-pounds of torque.



4. Tighten the top-right mounting screw.
5. Place a new tamper seal over two of the mounting screws as shown below.

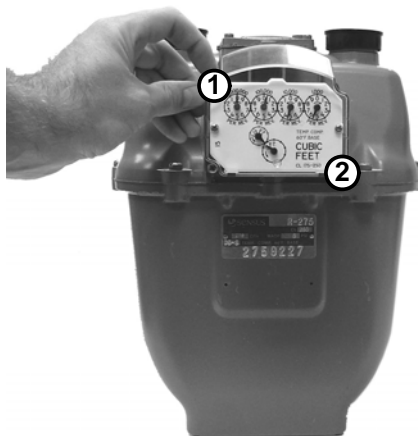

6. Press the new tamper seals into place using the 11/32-inch nut driver (or another similar blunt tool).

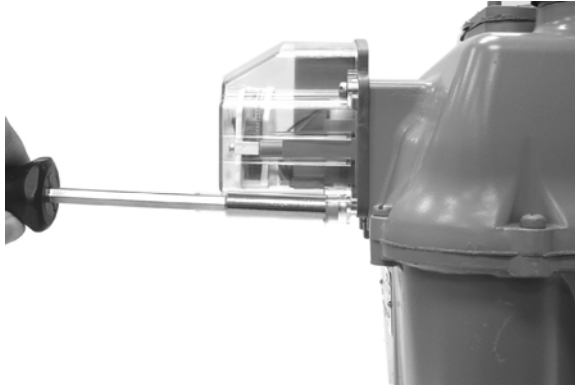

7. Complete any necessary paperwork. Make sure no excess material is left on the customer premises.

The ERT is now installed on the meter.

