

Sensus Meter Installation

This chapter shows you how to install a 100G ERT Module on a Sensus meter.



Sensus meters are also known by the following names: **Invensys**, **Equimeter**, and **Rockwell**. For consistency, all of these meter types will be referred to as Sensus meters for this installation procedure.

Installation Prerequisites

The following items are required to install the Itron 100G ERT Module.

Materials Supplied by Itron

The following items are supplied by Itron:

- 100G ERT Modules
- New tamper seals

Materials Supplied By You

You must supply the following items to install, initialize, and check the 100G ERT Module on the meter.

- **Small and medium flat-blade or Phillips screwdrivers** Used to remove and tighten index and index-cover screws.
- **Side-cutting plier/wire snips** Used for cutting wire seals, if necessary.
- **Small putty knife** Used to remove all traces of old gaskets from the meter.
- **Meter seals, wire seals, and seal press** Used to secure the meter from tampering, if necessary.
- **11/32-inch nut driver or other blunt tool** Used to securely seat new tamper plugs over screw holes.
- **Replacement screws** Used to mount 100G ERT Module assembly to meter and index to module assembly backplates.
- **FC200SR with EndPoint-Link or EndPoint-Link Pro software** Used to program and check ERT assembly.

Replacement Screws

Replacement screws used in this procedure are shown below.

For mounting 100G ERT Module assemblies on meters:

- Use 10 - 24 x 5/8-inch slotted, Fillister head screws.

For mounting indexes on 100G ERT Module backplates:

- Use 6 - 32 x 5/8-inch slotted, round head screws.

Preinstallation Preparations

Before installing the 100G ERT Module on a meter, verify that:

- All Itron gas modules are 100G ERT Modules for your brand of gas meters.
- The model numbers of all meters on which the 100G ERT Modules will be installed are included in the Meter Compatibility List.

Installing the 100G ERT Module

There are four major steps to installing the 100G ERT Module on a meter:

- Remove the index
- Assemble the 100G ERT Module
- Program the 100G ERT Module
- Attach the 100G ERT Module to the meter.



NOTE Properly dispose of all unused screws, old index covers, gaskets, tamper seals, and other left-over materials. Do not leave any materials on customer premises.

Remove the Existing Index

The first major step when installing a 100G ERT Module on an meter is to remove the index from the meter.

To Remove the Existing Index

1. Remove any tamper seals from the meter.

- Detach the index cover from the meter by removing the four screws holding it in place.

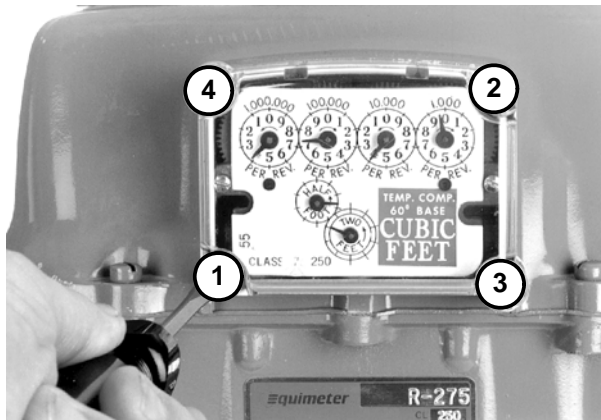

- Examine the index cover screws you just removed. Verify that they are 5/8-inch long and are not corroded.

- If the screws are 5/8-inch long and are not corroded, keep them for later use.
- If they are an incorrect length or are corroded, dispose of them properly. Use 10 - 24 x 5/8-inch screws as described in [Replacement Screws](#) on page 29 instead.



TIP You can use the index cover you just removed as a temporary storage location for screws.



NOTE Dispose of the index cover properly when finished with the installation procedure. Do not leave it on customer premises.

- Unscrew one index mounting screw completely.

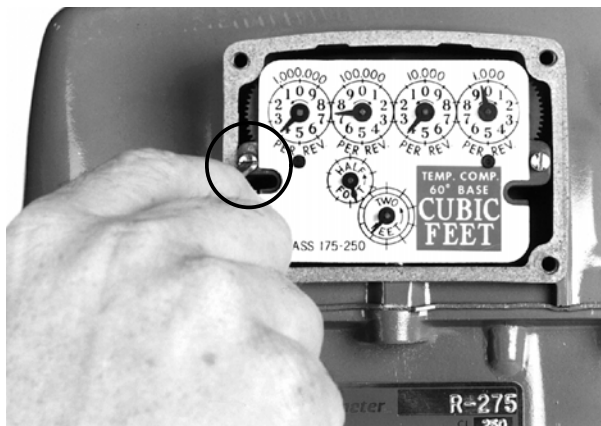

- Remove the other index mounting screw.
- Set the index aside for the moment. Place it where it will not be damaged; get filled with dirt, rain or snow; or fall to the ground or floor. The index will be used later in this procedure.
- Examine the index screws you just removed. Verify that they are 5/8-inch long and are not corroded.

- If the screws are 5/8-inch long and are not corroded, keep them for later use.
 - If the screws are an incorrect length or are corroded, dispose of them properly. Use 6 -32 x 5/8-inch screws as described in [Replacement Screws](#) on page 29 instead.
8. Use a putty knife or similar object to completely remove the old index gasket from the meter (if applicable). All traces of the gasket must be removed before the ERT can be installed.

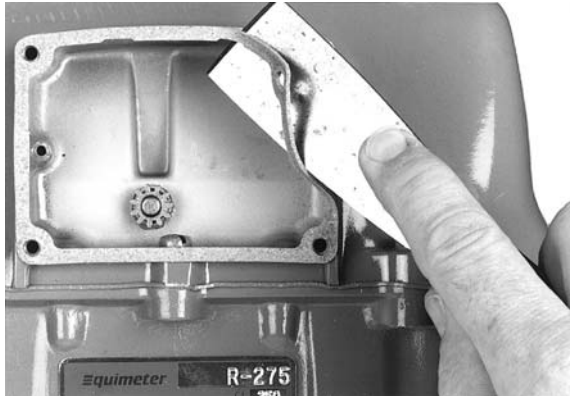

Assemble the ERT Module

When installing a 100G ERT Module, the next major step is to create the endpoint module assembly by combining the endpoint backplate and cover with the meter index. Follow the procedure below to do so.

To Assemble the ERT

1. Obtain a new 100G ERT module.
2. Separate the ERT module backplate from the cover.

3. Place the index drive gear (1) in the backplate wiggler gear cup (2) of the ERT (please note that the following example uses an 11-tooth drive gear; your index may have a 16- or 18-tooth drive gear, and you must use the appropriate 100G ERT module for your specific meter. See the [Meter Compatibility list](#) on page 6 for more information).

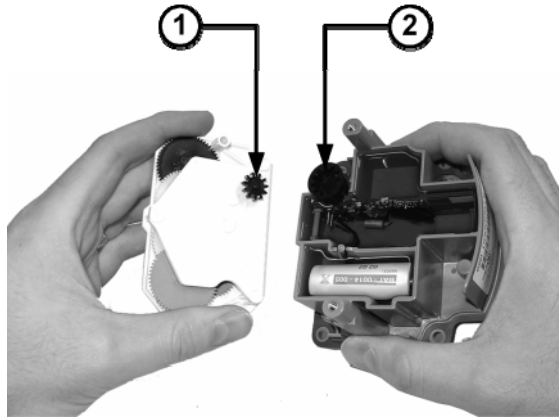

Once properly in place, the index drive gear and backplate wiggler cup should look similar to the following example.

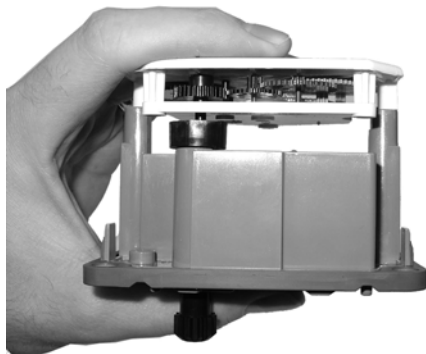

4. Attach the right-hand mounting screw to the index and meter, just far enough to hold the index in place. Use one 6 - 32 x 5/8-inch screw for this step (you can use an original mounting screw if it was the correct size and not corroded; otherwise, use the correct size [Replacement Screw](#) see "Replacement Screws" on page 29).



5. Install and tighten the left-hand index mounting screw.



6. Tighten the right-hand index mounting screw completely.
7. Slide the ERT cover over the index and backplate.

- 8. Verify that the cover is installed correctly.



Once combined, the ERT backplate, meter index, and ERT cover create an "ERT Module Assembly."

Next, program the ERT module.

Program the ERT

The ERT must be programmed using the FC200SR with EndPoint-Link software. See the *Endpoint-Link ERT Programming Guide (TDC-0411)* for more information.

i **IMPORTANT** You must perform the following programming procedure for the ERT module to function properly.

When programming the ERT module, you must take note of the drive rate shown on the index of the meter. Program the meter based on the drive rate shown on the index. Sensus meters have a 2-foot drive rate, as indicated in the example below (1), or a 0.05 cubic metre drive (not shown).

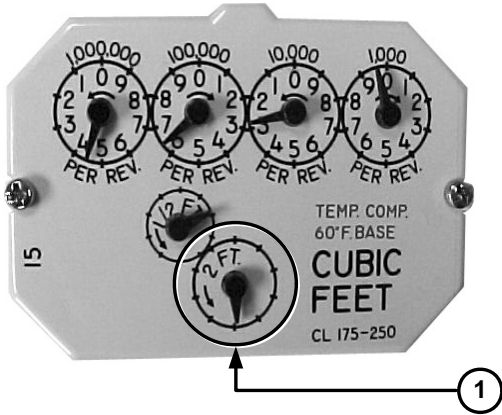

To Program the ERT Module

- 1. Using the FC200SR, program the reading of the index that was on the meter into the ERT module assembly.

- For initial programming, hold the FC200SR approximately 1 foot away from the 100G.
- For reprogramming (30 days or more past initial programming), hold the FC200SR approximately 4 to 5 feet away from the 100G.

Be sure to program the 100G to the correct mode for the reading technology what will be used (for example, Fixed Network Mode, Mobile/Handheld Mode, or Hard to Read Mobile/Handheld Mode). In Endpoint-Link Pro v5.0, you will have access to the one mode that was defined by your system administrator.

During programming, the 100G ERT module is programmed to the *nearest 100 cubic feet*; the last two digits (the tens and units) are programmed as zeros (0). Once programming is complete, however, the ERT module assembly can be read to the nearest cubic foot.

2. Slowly turn the ERT module drive wiggler two turns in the direction indicated on the index drive rate. This lets you verify the ERT module is counting properly after assembly.



IMPORTANT Do not turn the drive wiggler faster than *one turn per second*.

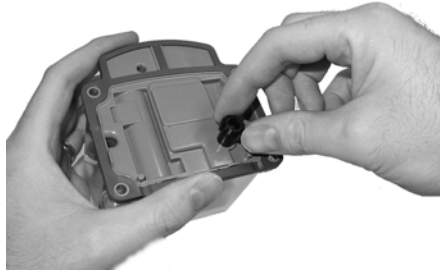

3. Read the ERT module assembly using the FC200SR. Consult the *EndPoint-Link ERT Programming Guide (TDC-0411)* or other applicable instructions for details on how to read an ERT.
 - If this reading is higher than the one you programmed in step 1 above, the ERT module assembly is counting correctly.
 - If the ERT module assembly reading is *not* higher than what was programmed in step 1, replace the ERT module with a new one.

Attach the ERT to the Meter

After the endpoint has been programmed and is reading correctly, it must be attached to the meter. Follow the steps below to do this.

To Attach the ERT to the Meter

1. Gently place the ERT module assembly against the front of the meter as shown. Make sure all four mounting screw holes in the ERT module assembly line up with the corresponding holes on the meter.



2. Insert the top-right cover mounting screw. Tighten the screw just enough to hold the ERT module assembly in place. Use the 10 - 24 x 5/8-inch screws for this and the following step (you can use the original mounting screws if they were the correct size and not corroded; otherwise, use the correct size as described in [Replacement Screws](#) on page 29).



3. Turn each screw 1/4 to 1/2 turn after it contacts the cover.



IMPORTANT Meter manufacturers should torque the mounting screws 15 to 20 inch-pounds.

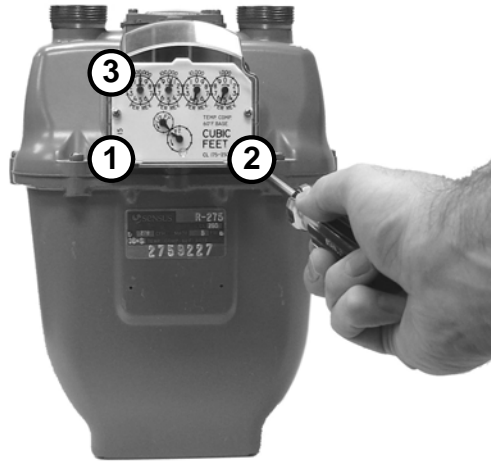

4. Place a new tamper seal over two of the mounting screws as shown below.

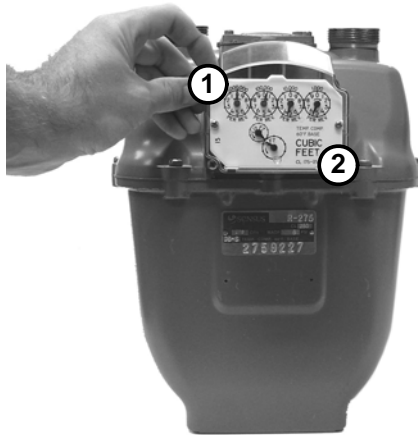

5. Press the new tamper seals into place using the 11/32-inch nut driver (or another similar blunt tool).

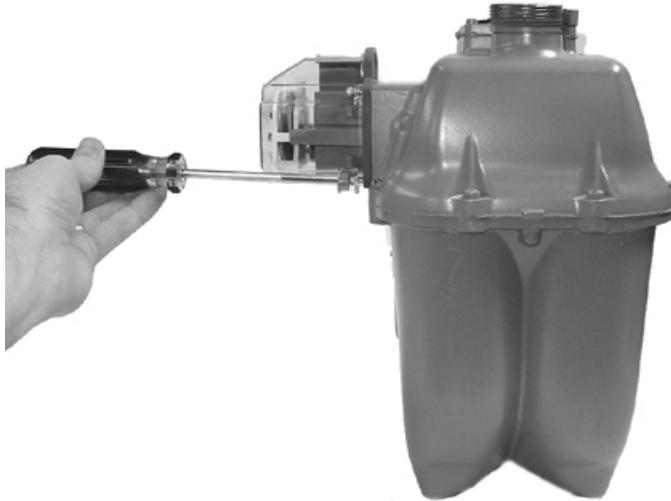

6. Complete any necessary paperwork. Make sure no excess material is left on the customer premises.

The ERT is now installed on the meter.



Actaris Meter Installation

This chapter shows you how to install a 100G ERT Module on an Actaris meter.



Actaris meters are also known by the names: **Sprague**, and **Schlumberger**. For consistency, all of these meter types will be referred to as Actaris meters for this installation procedure.

Before installing the 100G ERT Module, verify that you have:

- A compatible meter shown in the Meter Compatibility List.
- A compatible index. Itron 100G ERT Modules can be used with standard dial and direct read (odometer) indexes.
- The list of materials defined under Installation Prerequisites in this chapter.

Installation Prerequisites

The following items are required to install the Itron 100G ERT Module.

Materials Supplied by Itron

The following items are supplied by Itron:

- 100G ERT Modules
- New tamper seals

Materials Supplied By You

You must supply the following items to install, initialize, and check the 100G ERT Module on the meter.

- **Small and medium flat-blade or Phillips screwdrivers** Used to remove and tighten index and index-cover screws.
- **Side-cutting plier/wire snips** Used for cutting wire seals, if necessary.
- **Small putty knife** Used to remove all traces of old gaskets from the meter.
- **Meter seals, wire seals, and seal press** Used to secure the meter from tampering, if necessary.
- **11/32-inch nut driver or other blunt tool** Used to securely seat new tamper plugs over screw holes.
- **Replacement screws** Used to mount 100G ERT Module assembly to meter and index to module assembly backplates.

- **FC200SR with EndPoint-Link or EndPoint-Link Pro software** Used to program and check ERT assembly.

Replacement Screws

Replacement screws used in this procedure are shown below.

For mounting 100G ERT Module assemblies on meters:

- Use 10 - 24 x5/8-inch slotted, Fillister head screws.

For mounting indexes on 100G ERT Module backplates:

- Use 10 - 24 x 1/4-inch slotted, round head screws.

Preinstallation Preparations

Before installing the 100G ERT Module on a meter, verify that:

- All Itron gas modules are 100G ERT Modules for your brand of gas meters.
- The model numbers of all meters on which the 100G ERT Modules will be installed are included in the Meter Compatibility List.

Installing the 100G ERT Module

There are four major steps to installing the 100G ERT Module on a meter:

- Remove the index
- Assemble the 100G ERT Module
- Program the 100G ERT Module
- Attach the 100G ERT Module to the meter.



NOTE Properly dispose of all unused screws, old index covers, gaskets, tamper seals, and other left-over materials. Do not leave any materials on customer premises.

Remove the Index

The first major step when installing a 100G ERT Module on an meter is to remove the index from the meter.

To Remove the Index

1. Remove tamper seals from the meter.

2. Remove and keep the cover screws.



3. Remove the index cover from the meter.
4. Check the screws for length and corrosion. If they are 5/8 inches long and not corroded, you can use them to attach the 100G ERT Module to the meter.

If the screws are not the correct length, or are corroded, dispose of them properly. Replace them with the screws listed in [Replacement Screws](#) on page 42.

5. Use the index cover just removed as a temporary storage location for screws.



NOTE Dispose of the index cover properly when finished with the installation procedure. Do not leave it on customer premises.

6. Loosen the index mounting screws one-half turn.



7. Slide the index up off its mounting screws and remove it from the meter. Set the index where it won't get damaged or dirty.

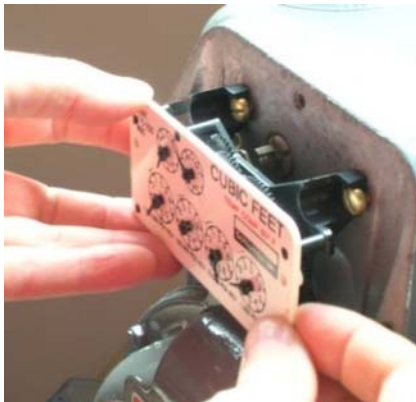

8. Remove the index mounting screws from the meter. Check the screws for length and corrosion. If they are 1/4 inches long and not corroded, you can use them to attach the 100G ERT Module to the meter.

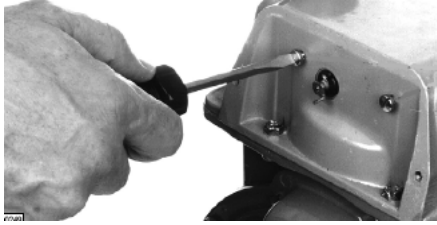

If the screws are not the correct length, or are corroded, dispose of them properly. Replace them with the screws listed in [Replacement Screws](#) on page 42.

9. Remove all traces of the old index gasket from the meter. The new 100G ERT Module has its own gasket.

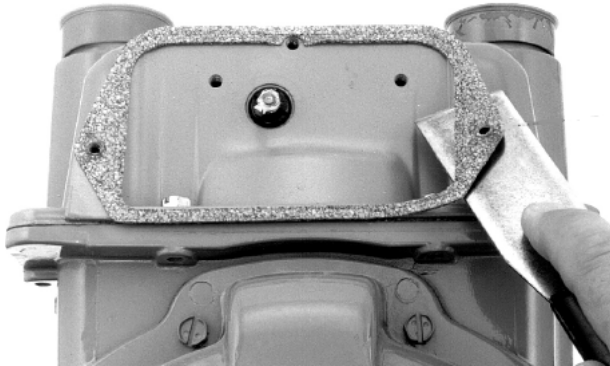

10. Dispose of the old gasket properly and do not leave it on the customer premises.

Assemble the ERT Module

When installing a 100G ERT Module, the next major step is to create the endpoint module assembly by combining the endpoint backplate and cover with the meter index. Follow the procedure below to do so.

To Separate the Cover from the Backplate

1. Obtain a new 100G ERT Module.

2. Place your thumb in the notch on the bottom of the endpoint to hold the backplate and pull the cover away from the backplate.

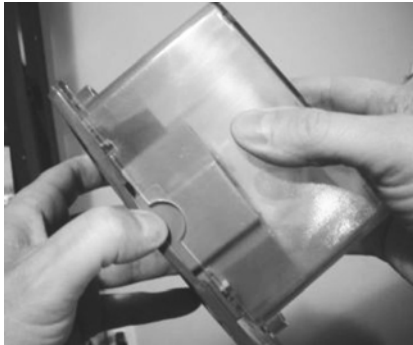

You can also separate the cover from the backplate by gently pulling on the wriggler until the backplate comes free.



3. Set the cover aside where it won't be damaged.
4. Put the index mounting screws about two turns into the backplate index mounting posts.



5. Position the backplate and index wrigglers as shown below.

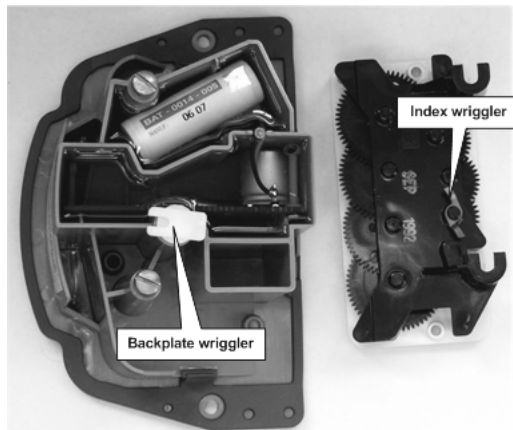

6. Slide the index mounting brackets onto the mounting screws.



7. Make sure the backplate wiggler post is below the index wiggler when lowering the index mounting brackets onto the index mounting screws.

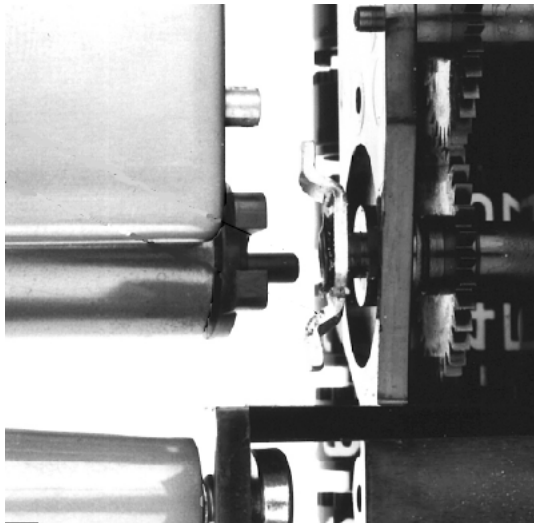

8. Hold the index in place with your thumb and tighten the index mounting screws.

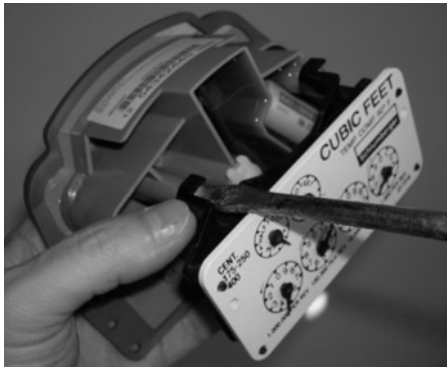

9. Slide the cover over the index and onto the backplate until it is against the gasket.

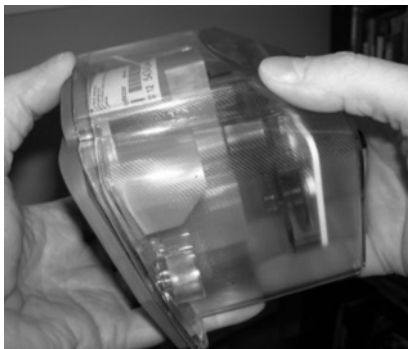

Program the ERT

The ERT must be programmed using the FC200SR with EndPoint-Link software. See the *Endpoint-Link ERT Programming Guide (TDC-0411)* for more information.



IMPORTANT You must perform the following programming procedure for the ERT module to function properly.

When programming the ERT module, you must take note of the drive rate shown on the index of the meter. Program the meter based on the drive rate shown on the index.

To program the ERT module

1. Using the FC200SR, program the reading of the index that was on the meter into the ERT module assembly.

- For initial programming, hold the FC200SR approximately 1 foot away from the 100G.
- For reprogramming (30 days or more past initial programming), hold the FC200SR approximately 4 to 5 feet away from the 100G.

Be sure to program the 100G to the correct mode for the reading technology what will be used (for example, Fixed Network Mode, Mobile/Handheld Mode, or Hard to Read Mobile/Handheld Mode). In Endpoint-Link Pro v5.0, you will have access to the one mode that was defined by your system administrator.

During programming, the 100G ERT module is programmed to the *nearest 100 cubic feet*; the last two digits (the tens and units) are programmed as zeros (0). Once programming is complete, however, the ERT module assembly can be read to the nearest cubic foot.

2. Slowly turn the ERT module drive wriggler two turns in the direction indicated on the index drive rate. This lets you verify the ERT module is counting properly after assembly.



IMPORTANT Do not turn the drive wriggler faster than *one turn per second*.

3. Read the ERT module assembly using the FC200SR. Consult the *EndPoint-Link ERT Programming Guide (TDC-0411)* or other applicable instructions for details on how to read an ERT.
 - If this reading is higher than the one you programmed in step 1 above, the ERT module assembly is counting correctly.
 - If the ERT module assembly reading is *not* higher than what was programmed in step 1, replace the ERT module with a new one.

Attach the ERT Module to the Meter

After the endpoint has been programmed and is reading correctly, it must be attached to the meter. Follow the steps below to do this.

To Attach the Endpoint to the Meter

1. Turn the white wriggler so one of its four drive slots lines up with the drive dog.

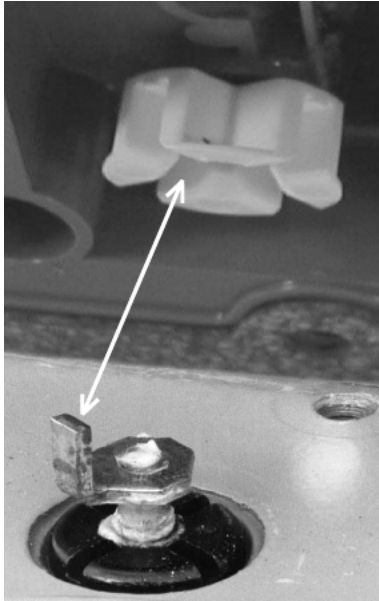

2. Gently place the 100G ERT Module on the meter.

If there is a gap between the gasket and the meter, it is probably because the drive slot of the ERT module assembly's wriggler is not properly aligned with the meter wriggler drive dog. To correct this, remove the assembly and repeat the alignment procedure in step one.

3. Turn each screw 1/4 to 1/2 turn after it contacts the cover.



IMPORTANT Meter manufacturers should torque the mounting screws 15 to 20 inch-pounds.





Only two screws are required to mount the 100G ERT Module. Dispose of the extra screw properly. Do not leave it on the customer premises.

4. Press new tamper seals into place with an 11/32 nut driver, or other blunt tool.



- 5.

Attaching the ERT Module to Flat-faced Model 1A Meters

If you want to install a 100G ERT Module on a flat-faced model 1A meter you will have to use the CFG-0015-001 adapter kit. Obtain the kit from Itron then use the following procedure to install the kit and the 100G ERT Module.

1. Make sure you have all of the following items in the kit.



**Adapter Shim Plate
(MLD-0003-029)**



**Drive Dog
(FAB-0026-001)**



**Index Mounting Screws
(SCR-0065-001)**

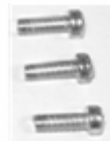

**Clear Cover Mounting Screws
(SCR-0066-001)**

2. Remove the drive dog from the meter and replace it with the one from the kit.



IMPORTANT Do not use a tool to install or tighten the new drive dog, hand tighten only.



3. Attach Adapter Shim Plate to the meter, as shown, using the two index mounting screws from the kit. Apply 15 to 20 inch-pounds of torque to the screws to provide a tight seal between the shim plate and the meter.



If the gasket is not attached to the shim plate, please request Itron PRA-0056-008.

4. Turn the white wriggler so one of its four drive slots lines up with the drive dog.

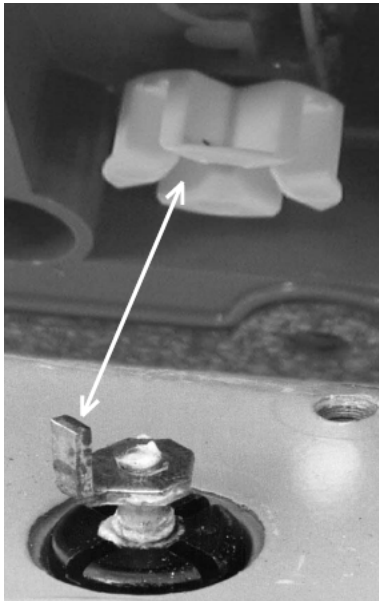

5. Gently place the 100G ERT Module on the meter.

If there is a gap between the gasket and the meter, it is probably because the drive slot of the ERT module assembly's wriggler is not properly aligned with the meter wriggler drive dog. To correct this, remove the assembly and repeat the alignment procedure in step one.

6. Turn each screw 1/4 to 1/2 turn after it contacts the cover.



IMPORTANT Meter manufacturers should torque the mounting screws 15 to 20 inch-pounds.



Only two screws are required to mount the 100G ERT Module. Dispose of the extra screw properly. Do not leave it on the customer premises.

7. Press new tamper seals into place with an 11/32 nut driver, or other blunt tool.



CHAPTER 5

American/Actaris Commercial Meter Installation

This chapter shows you how to install a 100G ERT Module on an American Commercial meter.

Before installing the 100G ERT Module, verify that you have:

- A compatible meter shown in the Meter Compatibility List.
- A compatible index. Itron 100G ERT Modules can be used with standard dial and direct read (odometer) indexes.
- The list of materials defined under Installation Prerequisites in this chapter.



IMPORTANT The 100G ERT Module must be handled carefully so that the metal passive radiator antenna does not get damaged.

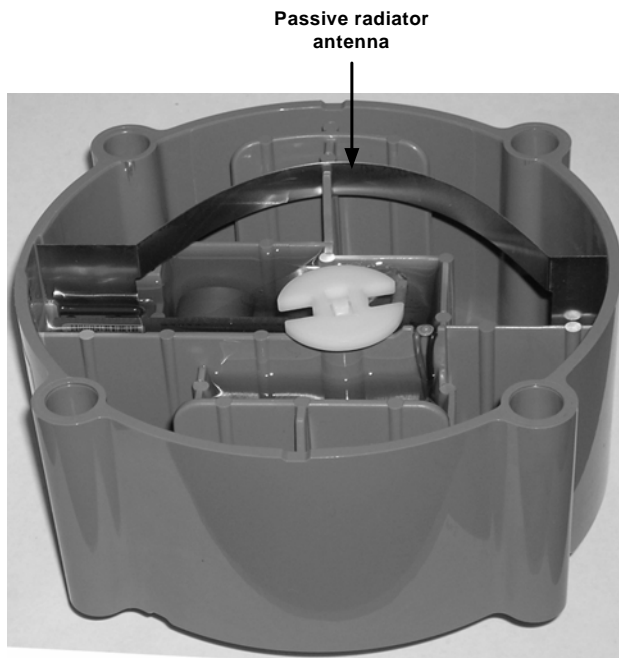

Installation Prerequisites

The following items are required to install the Itron 100G ERT Module.

Materials Supplied by Itron

The following items are supplied by Itron:

- 100G ERT Modules