



Knowledge to Shape Your Future

Natural Gas Solutions

100G Datalogging FN ERT Module Installation Guide - Remote Mount

Identification

100G Datalogging FN ERT Module Installation Guide - Remote Mount

01/10/2011 TDC-0824-003

100G Remote Mount ERT Module part numbers: ERG-5000-501, ERG-5000-502, ERG-5000-503

100G Datalogging Remote Mount ERT Module: ERG-5002-501, ERG-5002-502, ERG-5002-503, ERG-5002-505

100G Datalogging FN Remote Mount ERT Module: ERG-5003-501, ERG-5003-502, ERG-5003-503, ERG-5003-505

Copyright

© 2009 - 2010 - 2011 Itron, Inc. All rights reserved.

Confidentiality Notice

The information contained herein is proprietary and confidential and is provided subject to the condition that (i) it is held in confidence except to the extent required otherwise by law and (ii) is issued only for the purposes described herein. Any third party given access to this information is similarly bound in writing.

Trademark Notice

Itron is a registered trademark of Itron, Inc.

All other product names and logos in this documentation are used for identification purposes only and may be trademarks or registered trademarks of their respective companies.

Applicable Patents

U.S. Patent Numbers: 4,614,945; 4,753,169; 4,768,903; 4,799,059; 4,867,700

Canadian Patent Numbers: 1,254,949; 1,267,936; 1,282,118

Compliance Statement

This device complies with Part 15 of the FCC Rules. Operation of this device is subject to the following two conditions:

- This device may not cause harmful interference.
- This device must accept any interference that may cause undesirable operation.

This device must be permanently mounted such that it retains a distance of 20 centimeters (7.9 inches) from all persons in order to comply with FCC RF exposure levels.

Compliance Statement

This device complies with Industry Canada license-exempt RSS standard(s). Operation is subject to the following two conditions:

- (1) this device may not cause interference, and
- (2) this device must accept any interference, including interference that may cause undesired operation of the device.

Déclaration de conformité

Le présent appareil est conforme aux CNR d'Industrie Canada applicables aux appareils radio exempts de licence. L'exploitation est autorisée aux deux conditions suivantes :

- (1) l'appareil ne doit pas produire de brouillage, et
- (2) l'utilisateur de l'appareil doit accepter tout brouillage radioélectrique subi, même si le brouillage est susceptible d'en compromettre le fonctionnement.

Transportation Classification

The Federal Aviation Administration prohibits operating transmitters and receivers on all commercial aircraft. When powered, the 100G Datalogging FN remote ERT module is considered an operating transmitter and receiver and cannot be shipped by air. All product returns must be shipped by ground transportation.

Modifications and Repairs

To ensure system performance, this device and antenna shall not be changed or modified without the expressed approval of Itron. Any unauthorized modification will void the user's authority to operate the equipment.

Meter Installation/Removal

In the event of malfunction, all repairs should be performed by Itron. It is the responsibility of users requiring service to report the need for service to Itron.



Warning Follow these procedures to avoid injury to yourself or others:

- The lithium battery may cause a fire or chemical burn if it is not disposed of properly.
- Do not recharge, disassemble, heat above 100° Celsius (212° Fahrenheit), crush, expose to water, or incinerate the lithium battery. Fire, explosion, and severe burn hazard.
- Keep the lithium battery away from children.
- Replace the lithium battery only with batteries meeting Itron specifications. Any other battery may cause a fire or explosion.



Warning Only authorized Itron personnel should attempt repairs on Itron equipment. Attempts to do so by others might void any maintenance contract with your company. Unauthorized service personnel might also be subject to shock hazard on some Itron equipment if removal of protective covers is attempted.



Warning To prevent ignition of flammable or combustible atmospheres, disconnect power before servicing.



Warning Substitution of components may impair intrinsic safety.

Suggestions

If you have comments or suggestions on how we may improve this documentation, send them to TechnicalCommunicationsManager@itron.com

If you have questions or comments about the software or hardware product, contact Itron Technical Support:

Contact

- Internet: www.itron.com
- E-mail: support@itron.com
- Phone: 1 877 487 6602

Contents

Before You Begin	v
Document Purpose.....	v
Chapter 1 100G Datalogging FN Remote ERT Module	1
Transmission Modes	1
Specifications	2
Related Documents	2
100G Datalogging FN Remote ERT Module Meter Compatibility List	3
Installation Prerequisites	5
Chapter 2 Mounting the 100G Datalogging FN Remote ERT Module.....	6
Installation Options.....	6
Mounting Screw Specifications	6
Mounting Installation Considerations	7
Mounting the Remote ERT Module on a Pipe	8
Mounting the ERT Module on a Wall or Other Flat Vertical Surface	14
Chapter 3 Rotary Meter Installation	16
Required Installation Materials Available from Itron.....	17
Programming the Remote ERT Module for Dresser ROOTS® Rotary Meters.....	19
B3, LMMA & S3A CTR/TC Meter Drive Rates for Remote ERT Module Programming	20
Installing the Remote ERT Module to the Elster American Meter RPM Series Rotary Meter	21
Mounting the 100G Datalogging FN Remote Mount ERT Module.....	27
Installing the Remote ERT Module to the Romet Electronically Compensated Meter (ECM2®)	27
Connecting the Remote ERT Module to the Romet ECM2® Meter.....	28
Rommet ECM2® Mounting Requirement.....	28
Programming the 100G Datalogging FN Remote ERT Module	31
Chapter 4 Electronic Volume Corrector and Instrument Installation	33
Installation Prerequisites	34
Installation Overview	34
Programming the Mercury Instrument.....	35
Code Settings.....	35
Wiring the ERT Module to the Instrument	36
Wiring Dual ERT Modules to a Mercury Instrument.....	38
Wiring the Remote ERT Module to the Mercury TCI	40
Connecting the 100G Datalogging FN Remote Mount ERT Module to the IMC/W2 or MC2 Cable	43
Installing the ERT Module to the Dresser ROOTS® Micro Corrector (IMC/W2 or MC2)	46
Programming the 100G Datalogging FN Remote ERT Module	50

Chapter 5 Diaphragm Meter Installation	52
Tools and Materials Supplied By You	52
Materials Available from Itron.....	53
Replacement Gaskets.....	53
Installing the 100G Datalogging FN Remote ERT Module	54
Installing 100G Datalogging FN Remote ERT Module Encoders	55
Index Cover Installation Required Materials	60
Programming the 100G Datalogging FN Remote ERT Module	64
Chapter 6 DATTUS Meter Installation	66
Installation Prerequisites	66
Programming the DATTUS Meter	66
Installation Overview	66
Installing the Remote ERT Module to Itron DATTUS Meters	67
Mounting the 100G Datalogging FN Remote ERT Module	70
Programming the 100G Datalogging FN Remote ERT Module	71
Chapter 7 Sensus Sonix Meter Installation	73
Programming the Sensus Sonix Meter	73
Adjusting the Pulse Output for Sonix 600 and 880 Meters	73
Installing the 100G Datalogging FN Remote ERT Module with Sensus Sonix Meters	74
Sensus Sonix2000 Pulse Output Wiring	74
Direct Mounting the Remote ERT Module to the Sonix Meter	75
Connecting the Remote ERT Module to a Sensus Sonix 600 or 880 Meter	76
Programming the 100G Datalogging FN Remote ERT Module.....	77
Index	79

Before You Begin

The following documentation conventions are used:



Caution A Caution warns the user that failure to heed the information in the note could result in loss of data. Be sure to carefully read a Caution note and follow the advice/instructions.



Warning A Warning alerts you about potential physical harm to the user or hardware. It is critical that you pay strict attention to Warning notes, read the information carefully, and follow the advice/instructions.



Tip A Note provides the user with extra hints to make a task easier to perform or a concept easier to understand.



Note A Note supplies generic information to the user. The user could ignore the information and continue a task without suffering any adverse consequences.

Document Purpose

This installation guide provides step-by-step instructions for installing the 100G Series remote gas ERT module on a wide variety of meters and instruments. This installation guide refers to the 100G series remote ERT module as the 100G Datalogging FN remote ERT module. Mechanical and electrical installation procedures are similar for all modules. 100G Datalogging FN remote ERT module compatible meters and instruments are listed in the [100G Datalogging FN Remote ERT Module Meter Compatibility List](#) on page 3.

100G Datalogging FN ERT Module

Itron 100G series remote ERT modules are radio-frequency (RF) devices designed to transmit meter data to an RF meter reading device within transmission distance of the remote ERT module. The 100G remote gas ERT module was designed with a higher output power than earlier Itron remote gas ERT modules to achieve an increased RF transmission distance. The 100G series remote gas ERT modules have greater output power to meet Itron mobile and fixed network requirements. The first 100G remote gas ERT module offered high transmit power capability which increased operational efficiency and reduced infrastructure costs. The 100G Datalogging remote gas ERT module offers high transmit power with data logging capability (time-stamped hourly interval data) for both mobile and fixed network applications. Itron's 100G Datalogging Fixed Network (DLN) remote gas ERT module adds improved network performance through even higher transmit power, accomplished using increased antenna efficiency and more robust optimized messaging structures.

The 100G Datalogging FN remote ERT module features tilt-tamper and cut cable-tamper reporting and security seals to indicate physical tampering and minimize theft. Cut cable is reported when the cable is cut or disconnected from the meter, instrument, or endpoint. 100G Datalogging FN remote ERT module circuitry senses an electrical current *break* to report a cut cable tamper event.

Transmission Modes

The 100G Datalogging FN remote ERT module can be set to transmit in Fixed Network, Mobile and Handheld, or Hard to Read Mobile and Handheld Mode.

- **Fixed Network Mode.** The 100G Datalogging FN remote gas ERT transmits a high-powered network interval message (NIM) RF message every five minutes. Output power in this mode is 500 milliwatts or +27 dBm. Interspersed in the high power NIM, the 100G Datalogging FN remote ERT module transmits a medium power RF message at 10 milliwatts or +10 dBm; expected battery life is 20 years.
- **Mobile High Power Mode.** The 100G series remote gas ERT transmits a high-powered RF message every 60 seconds. Output power in this mode is 250 milliwatts or +24dbm; expected battery life is 20 years.
- **Mobile and Handheld Mode.** The 100G series remote gas ERT transmits a medium-powered RF message every 15 seconds. Output power in this mode is 10 milliwatts or +10dBm; expected battery life is 20 years.
- **(Optional) Hard to Read Mobile and Handheld Mode.** The 100G series remote FN gas module transmits a high-powered RF message every 30 seconds. Output power in this mode is 250 milliwatts or +24dBm; expected battery life decreases to 15 years in this mode. The *Hard to Read Mobile and Handheld Mode* should only be used for exceptionally hard-to-read applications (such as meters installed on roof tops or in sub-basements).

An FCC license is not required to read 100G series remote gas ERT modules.

Specifications

The functional and operational specifications for the 100G Datalogging FN remote ERT module are listed below.

Functional Specifications	Description
Power source	Two "A" cell lithium batteries
Tamper detection	Tilt tamper and cut cable tamper
FCC compliance	Part 15 certified
Industry Canada compliance	RSS-210 certified
Intrinsically safe per	UL Class I, Division 1, Groups C and D
Product identification	Numeric and bar-coded ERT module type and serial number
Construction materials	Gray polycarbonate housing and back plate with encapsulated electronics

Operational Specifications	Description
Operating temperatures	-40° to 158° F (-40° to +70° C)
Operating humidity	5 to 95 percent relative humidity
Program frequency	908 MHz
Transmit frequency	Spread spectrum 908 to 924 MHz ISM band
Data integrity	Verified in every data message

Related Documents

Document Title	Document Part Number
<i>Gas Endpoint Meter Compatibility List</i>	PUB-0117-002
<i>Gas Endpoint Ordering Guide</i>	PUB-0117-001
<i>100G Datalogging Specification Sheet</i>	Publication 100941SP-XX
<i>Endpoint Link Programming Guide</i>	TDC-0744*
<i>Field Deployment Manager Endpoint Tools Mobile Application Guide</i>	TDC-0934*
<i>Field Deployment Manager Field Representative's Guide</i>	TDC-0936*

*The last three digits of the user and installation guides represent the document's revision level. The revision level is subject to change without notice.

100G Datalogging FN Remote ERT Module Meter Compatibility List

This table lists meters compatible with the 100G Datalogging FN remote ERT module. Due to continuous research, product improvements, and enhancements Itron reserves the right to change this list without notice.

Meter	Model	Description	Class	Comments	ERT Module Type	ERT Module Part Number
Elster/American/ Canadian	10 Metric (10B)	Iron case	Residential	2.5' cable with encoder	100G Remote 100G Datalogging Remote 100G Datalogging FN Remote	ERG-5000-501 ERG-5002-501 ERG-5003-501
Sensus/Invensys	Sonix 12,16,25,57, 600,880,2000	Pulser Metric Cubic foot	Commercial	12" lead wires	100G Remote 100G Datalogging Remote 100G Datalogging FN Remote	ERG-5000-503 ERG-5002-503 ERG-5003-503
National/ Lancaster	All meters	Where direct mount is not compatible	Residential	2.5' cable with encoder	100G Remote 100G Datalogging Remote 100G Datalogging FN Remote	ERG-5000-501 ERG-5002-501 ERG-5003-501
Itron/Actaris/ Schlumberger/ Sprague	1A	Where direct mount is not compatible	Residential	2.5' cable with encoder	100G Remote 100G Datalogging Remote 100G Datalogging FN Remote	ERG-5000-501 ERG-5002-501 ERG-5003-501
Itron/Actaris/ Schlumberger/ Sprague	Metris 250	Straight Face meter	Residential	2.5' cable with encoder	100G Remote 100G Datalogging Remote 100G Datalogging FN Remote	ERG-5000-501 ERG-5002-501 ERG-5003-501
Itron/Actaris/ Schlumberger/ Sprague	305	#2 flat-face meter		2.5' cable with encoder	100G Remote 100G Datalogging Remote 100G Datalogging FN Remote	ERG-5000-501 ERG-5002-501 ERG-5003-501
Itron/Actaris/ Schlumberger/ Sprague	400	#3 flat-face meter		2.5' cable with encoder	100G Remote 100G Datalogging Remote 100G Datalogging FN Remote	ERG-5000-501 ERG-5002-501 ERG-5003-501
Itron/Actaris/ Schlumberger/ Sprague	675, 1000	Front mount index	Commercial	2.5' cable with encoder Also requires thicker gasket for magnet hub to clear index box. 1-hole gasket: FAB-0014-001 2-hole gasket: FAB-0014-002 4-hole gasket: FAB-0014-003	100G Remote 100G Datalogging Remote 100G Datalogging FN Remote	ERG-5000-501 ERG-5002-501 ERG-5003-501
Elster American	TC and STD CTR	American RPM series rotary meters including TC and non-TC.	Commercial	Meter must have a factory installed pulser with connector output. Purchase endpoint from Itron and correct cable interface from appropriate meter manufacturer.	100G Remote (12' lead wires) 100G Datalogging Remote (12" lead wires) 100G Datalogging FN Remote (12" lead wires)	ERG-5000-503 ERG-5002-503 ERG-5003-503
Romet	STD CTR 600 through 56000 TC 2000 through 23000	RM series	Commercial	Meter must have a factory installed pulser with connector output. Purchase endpoint from Itron and correct cable interface from appropriate meter manufacturer.	100G Remote (12' lead wires) 100G Datalogging Remote (12" lead wires) 100G Datalogging FN Remote (12" lead wires)	ERG-5000-503 ERG-5002-503 ERG-5003-503

Meter	Model	Description	Class	Comments	ERT Module Type	ERT Module Part Number
Romet	RM Series	ECM2 Electronically compensated meter	Commercial	Meter must have connector pin with factory-installed pulse output. Purchase endpoint from Itron and correct cable interface from Romet. ECM2 must be configured for 750ms "off-time" between pulses. The ECM2 must have firmware version J or later.	100G Datalogging Remote (12" lead wires) 100G Datalogging FN Remote (12" lead wires)	ERG-5002-503 ERG-5003-503
Dresser ROOTS®	B3/LMMA	Dresser ROOTS® rotary meters equipped with WeigandWire solid state pulsers	Commercial	Meter must have factory-installed pulser with connector output. Purchase endpoint from Itron and correct cable interface from Dresser. Dresser pulser must be version 17 or higher to be compatible.	100G Remote (12" lead wires) 100G Datalogging Remote (12" lead wires) 100G Datalogging FN Remote (12" lead wires)	ERG-5000-503 ERG-5002-503 ERG-5003-503
Dresser ROOTS®	IMC/W2 MC2	Dresser ROOTS® Micro Correctors	Commercial	Endpoint compatible with IMC/W2 firmware version 1.93 or earlier. Pulse width must be set for 125ms. Pulse output must be at 100CF(CM) or higher.	100G Datalogging Remote (12" lead wires) 100G Datalogging FN Remote (12" lead wires)	ERG-5002-505 ERG-5003-505
Itron/Actaris	DATTUS fM2/fM3		Commercial	For all meter types, pulse width must be set to .050 seconds. Meter type 11M or smaller must have pulse weight minimum of 10 cubic feet or 1 cubic meter. Meter type 16M or greater must have pulse weight minimum of 100 cubic feet or 1 cubic meter.	100G Datalogging Remote (5' cable) 100G Datalogging FN Remote (5' cable)	ERG-5002-502 ERG-5003-502
Mercury Instruments	EC-AT Mini-P Mini-AT Mini-Max	Pressure and temperature electronic volume correctors	Commercial	Correctors must have a Form A board; Form C is NOT supported. Item #056 Pulse Scaling Factor must be set to 2.0. Item #096 Cor Vol Display must be set at 1, 2, 3, or 4 blanks. endpoint does NOT support a setting of 0 blanks. Item #115 Output Pulse Code must be set at 1, 2, 3, or 4. endpoint does NOT support an Output Pulse Code of 0.	100G Remote (5' cable) 100G Datalogging Remote (5' cable) 100G Datalogging FN Remote (5' cable)	ERG-5000-502 ERG-5002-502 ERG-5003-502
Mercury Instruments	TCI	Temperature Compensating Index	Commercial	Correctors must have a Form A board. Form C is NOT supported. Item #56 Pulse Scaling Factor must be 2.0. Item #96 must be 7, 6, 5, or 4 digits (1, 2, 3, & 4 blanks). Endpoint does NOT support 8 digits (0 blanks). Item # 1014 set to the preset "Itron" selection in the drop down menu. Compatible firmware versions on TCI are 1.06, 1.07, and 1.10.	100G Datalogging Remote (5' cable) 100G Datalogging Remote (12" lead wires) 100G Datalogging FN Remote (5' cable) 100G Datalogging FN Remote (12" lead wires)	5": ERG-5002-502 12": ERG-5002-503 ERG-5003-502 ERG-5003-503

Installation Prerequisites

The following tools are required to install, program, and check the 100G Datalogging FN remote ERT module. Some specific tools may be required dependent on meter or instrument type.

- Medium flat-blade screwdriver
- Small flat-blade screwdriver
- Medium Phillips screwdriver
- Hand pliers
- Side-cutting pliers
- 1/4-inch nut driver or similar blunt tool
- One-inch width putty knife
- Adjustable wrench
- 3M Scotchlock E-9Y crimping tool, 3M Scotchlock E-9C cartridge tool, or similar crimping tool
- All-weather electrical tape
- Size T-10 Torx screwdriver
- Itron programming device to program and check 100G Datalogging FN remote gas ERT module installation and operation:

FC200SR handheld computer with Endpoint-Link or Endpoint-Link Pro software version 5.3 or higher or Field Deployment Manager (FDM) software version 1.1 or higher

or

FC300 with SRead with Endpoint-Link or Endpoint Link Pro version 5.5 or higher or Field Deployment Manager (FDM) software version 1.1 or higher

or

900 MHz Belt Clip Radio with Endpoint-Link version 5.5 or higher or Field Deployment Manager (FDM) software version 1.1 or higher and a customer-supplied laptop



Note Reference the appropriate programming guide or specification sheet for correct software version (see [Related Documents](#) on page 2).

Mounting the 100G Datalogging FN Remote ERT Module



This chapter provides the instructions to mount the 100G Datalogging FN remote ERT module on a pipe or other flat vertical surface (wall).

Installation Options

Mount the 100G Datalogging FN remote ERT module using the Pipe Mount or Wall Mount (Flat Surface) procedure.

- **Pipe Mount.** Pipe mounting is used in conjunction with the Remote Mount Kit (Itron part number CFG-0005-003). The pipe mount option places the ERT module on a pipe near the meter or instrument (not on a wall surface). This option requires a meter manufacturer's cable to connect the ERT module to the meter or instrument.
- **Flat Vertical (Wall) Mount.** Installation using the wall mount option places the ERT module on a wall or other vertical surface. A cable connects the ERT module to the meter or instrument.

Mounting Screw Specifications

Application	Itron Part Number		Description
To mount adapter plates on pipe brackets	575-9930-016		8-16 x 1/2-inch length, Type 8 slotted pan-head tapping screw - corrosion-resistant steel
To mount remote ERT modules on adapter plates	575-9930-032		8-16 x 1-inch Type 8, slotted pan-head tapping screw, corrosion-resistant steel
To mount remote ERT modules on sheet metal surfaces (to mount ERT modules to wood surfaces, a comparable wood screw is required)	SCR-0009-001		10-16 x 1 1/2-inch Type AB thread for sheet metal, Phillips pan-head tapping screw, corrosion-resistant steel

Mounting Installation Considerations

Select a proper mounting location. Itron recommends mounting the 100G Datalogging FN remote ERT module in close proximity to the meter or instrument. Some applications may require an extended cable-length. The 100G Datalogging FN remote ERT module supports cable lengths up to 300 feet.

Mount the 100G Datalogging FN remote ERT module in a vertical position with the ERT module label directional arrow pointed upward.



Caution Upright vertical positioning is very important because:



- 100G Datalogging FN remote gas modules are designed with the antenna in a vertical direction so the antenna is parallel to the reading device (which has a vertical antenna). Matching antenna polarity can greatly affect RF performance and enable easy ERT module reading.
- 100G Datalogging FN remote gas modules are designed so the tilt tamper is vertical. It is important to maintain vertical positioning in the field to enable tilt tamper stability.



Warning Do not mount the 100G Datalogging FN remote ERT module in an orientation other than vertical (remote ERT module label arrow pointed upward or downward). Violating the mounting orientation requirements will void the product warranty.

Mounting the Remote ERT Module on a Pipe

The following items are required to mount the 100G Datalogging FN remote ERT module on a pipe or vertical flat surface (wall):

Itron Part Number	Description	
ERG-5003-501 ERG-5003-502 ERG-5003-503 ERG-5003-505	100G Datalogging FN Remote ERT Module	 <p>(ERG-5003-501 shown)</p>
CFG-0005-003	Remote Mount Installation Kit Kit includes: <ul style="list-style-type: none"> • 2 band clamps • 2 tamper seals • pipe bracket • cable ties • adapter plate Screws: <ul style="list-style-type: none"> • (2) 1/2-inch - to attach the adapter plate to pipe bracket • (2) 1-inch - to attach the ERT module to the adapter plate • (3) 1 1/2-inch - to attach the ERT module to a vertical surface (wall) 	

 **Warning** Install the 100G Datalogging FN remote ERT module in an upright position. Any position other than upright can negatively affect radio performance and potentially reduce battery life.

To mount the pipe bracket on a vertical pipe

 **Caution** Vertical mounting position is important to maximize RF performance. Mount the 100G Datalogging FN remote ERT module with the module's label arrow pointing up. *The module's arrow must never point to either side or upside down.* The module's tilt tamper functionality is designed to operate with the module installed vertically.

1. Remove the pipe bracket and band clamp from the Remote Mount Installation Kit (Itron part number CFG-0005-003).



- Loosen the band clamp screw until the end of the band releases.



- Push the end of the clamp's band (1) through the holes (2) in the pipe bracket. The pipe bracket must be oriented as shown below.

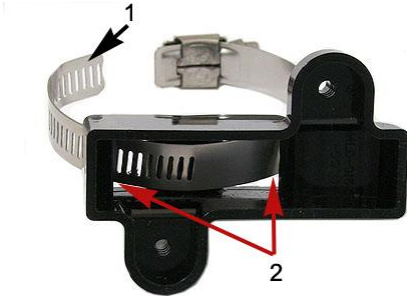

- Place the band clamp around the pipe. The band will loosely wrap around the pipe. Push the end of the band through the band clamp screw assembly. Turn the band clamp's screw assembly to fit into the pipe bracket opening. Tighten the clamp screw until the band clamp is secure on the pipe.

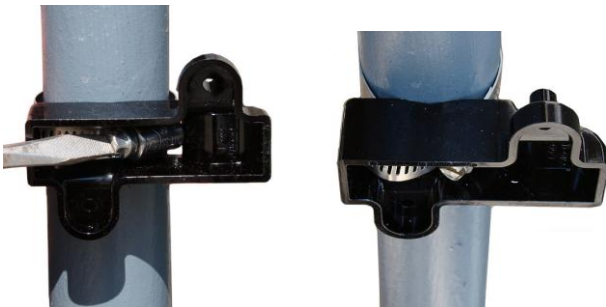

Caution The pipe bracket must fit firmly against the pipe to prevent slippage.

To mount the adapter plate on the pipe bracket

Caution Vertical mounting position is important to maximize RF performance. Mount the 100G Datalogging FN remote ERT module with the module's label arrow pointing up. *The module's arrow must never point to either side or upside down.* The module's tilt tamper functionality is designed to operate with the module installed vertically.

1. Place the adapter plate on the pipe bracket with the mounting lug at the top or bottom. The adapter plate screw bosses fit into the pipe bracket recess.

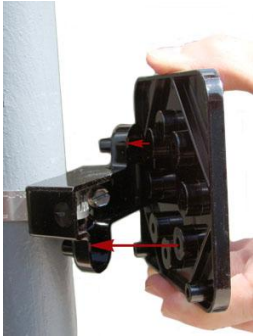

2. Ensure the adapter plate is positioned as shown below with the mounting lug (1) at the top or bottom. To install the adapter plate on a vertical pipe, use the two shortest (1/2-inch) adapter plate mounting screws from the Remote Mount Installation Kit. Place the mounting screws (2) in the holes shown below.

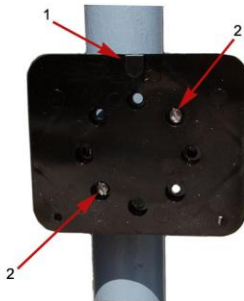

Upright module mounting

3. Tighten both screws securely in an alternating fashion. Itron recommends 9 to 12-inch-pounds torque.

To mount the 100G Datalogging FN remote ERT module on the adapter plate

1. Take the 100G Datalogging FN remote ERT module and the two one-inch mounting screws from the Remote Mount Installation kit. Place the back of the remote endpoint against the face of the adapter plate. The adapter plate mounting lug (1) must be positioned just above the endpoint mounting lug recess (2).

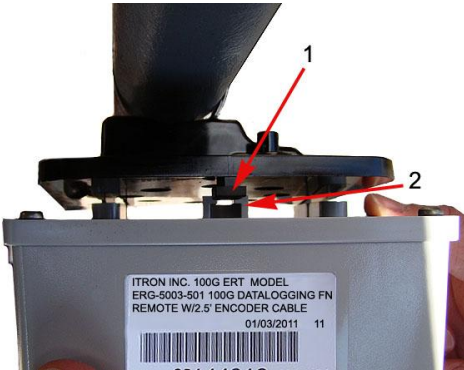

2. Push up on the 100G Datalogging FN remote ERT module until the adapter plate mounting lug (1) is as far as possible inside the module mounting lug recess (2).



3. Install the two one-inch ERT module mounting screws from the installation kit.



4. Tighten the module mounting screws evenly in an alternating fashion. Itron recommends 9 to 12 inch-pounds of pressure.

Adapter Plate Mounting Positions

The following pictures show adapter plates mounted on horizontal or 45-degree angle pipes.



Caution Regardless of the pipe's direction, the adapter plate mounting lug must always be at the top.

If the pipe is a 45 degree angle up to the right, install the adapter plate as shown below.

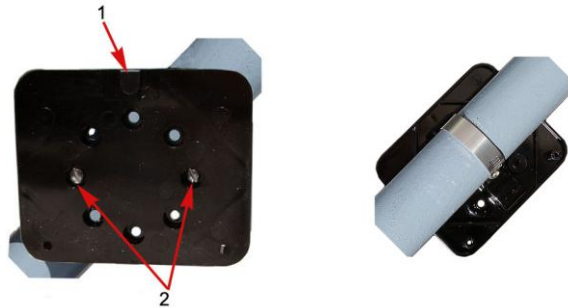

Typical module mounting

Mounted adapter plate

If the pipe is a 45 degree angle up to the left, install the adapter plate as shown below.

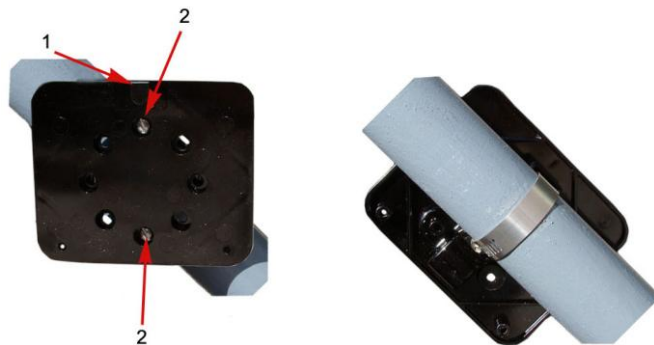

Typical module mounting

Mounted adapter plate

If the pipe is horizontal, install the adapter plate as shown below.

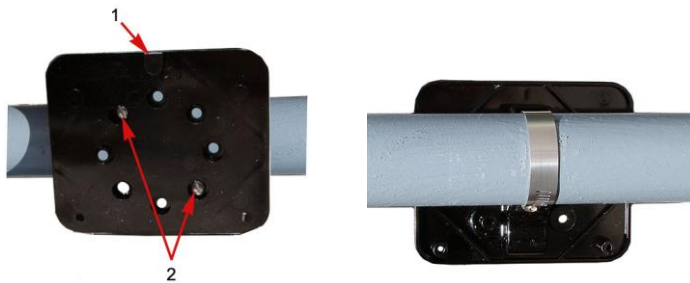

Typical module mounting

Mounted adapter plate

To install tamper seals and cable ties

1. Place the new tamper seals from the Remote Mount Installation Kit over the 100G Datalogging FN remote ERT module mounting screws.



2. Firmly push both tamper seals all the way into place with a 1/4-inch nut driver or similar blunt tool.



Note A tamper seal is fully seated when the top of the tamper seal is approximately 1/16 inch below the top of the screw recess.

3. Gather any excess ERT module cable. Loop a cable tie around the pipe and excess module cable.



4. Insert the chiseled end of the cable tie into the locking end and pull the cable tie tight. Cut off and properly dispose the excess cable tie.



100G Datalogging FN remote ERT module pipe mount installation is complete.

Mounting the ERT Module on a Wall or Other Flat Vertical Surface

To mount the 100G Datalogging FN remote ERT module on a wall or other flat vertical surface

Note For easier installation, you may drill three pilot holes in the mounting surface (use the proper size drill bit to accommodate the module mounting screws, see the Drilling Template below). When drilling pilot holes to mount the 100G Datalogging FN remote ERT module, the holes for the two bottom screws must be on a horizontal line. If you will mount the module on a sheet metal surface, use the mounting screws included with the 100G Datalogging FN remote ERT module mounting kit. Use a comparable wood screw to mount the module on a vertical wood surface.

Carefully select a mounting location free from electrical wires. The mounting location must have the proper clearance to accommodate the 1-1/2-inch module mounting screws so nothing is damaged by the drill or mounting screws.

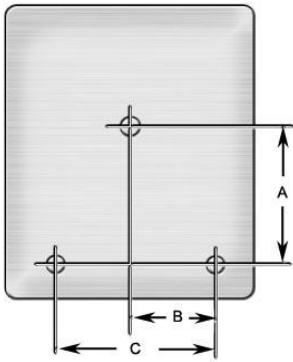

100G Datalogging FN Remote ERT Module drilling template

- A 3 inches
- B 1-11/16 inches
- C 3-3/8 inches

1. Using the three 1-1/2-inch mounting screws from the Remote Mount Installation Kit, turn the mounting screw for the mounting lug (top of module) part way into the mounting surface.

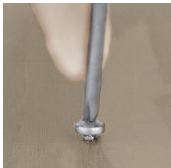

2. Place the 100G Datalogging FN remote ERT module mounting lug recess (on the top of the module's backplate) just under the screw head. Slide the module upward until the screw head fits completely inside the mounting lug recess. Several adjustments may be necessary to properly position the screw for module mounting.



3. Install the bottom two mounting screws. Fasten screws in an alternating fashion until fully tightened to secure the module firmly in position.



To install tamper seals and cable ties

1. Place a new tamper seal (from the Remote Mount Installation Kit) over each endpoint mounting screw.



2. Firmly push both tamper seals into place with a 1/4-inch nut driver or similar blunt tool.

Note A tamper seal is fully seated when the top of the tamper seal is approximately 1/16-inch below the top of the screw recess.

3. To reduce the risk of cable damage, secure the excess module cable with the cable ties from the Remote Mount Installation Kit. Pull the cable tight. Remove and properly dispose the excess cable tie.



100G Datalogging FN remote ERT module installation on a vertical flat surface or wall is complete.

CHAPTER 3

Rotary Meter Installation

This chapter provides the instructions to install the Datalogging FN remote ERT module on rotary gas meters. Reference the Gas Endpoint Meter Compatibility List (see [100G Datalogging FN Remote ERT Module Meter Compatibility List](#) on page 3) for rotary meters compatible with the 100G Datalogging FN remote ERT module .



American rotary meter



Dresser ROOTS® Series LMMA rotary meter



Dresser ROOTS® series B3 meter



Romet Imperial series RM meter



Romet Imperial ECM2 meter

Required Installation Materials Available from Itron

The materials in the following table are required to install a 100G Datalogging FN remote ERT module.

Itron Part Number

ERG-5003-503

Note this remote ERT module comes standard with 12-inch lead wires and may be shipped directly to the meter manufacturer for a factory-installed cable (interface). The interface cable must be purchased directly from the meter manufacturer.



ERG-5002-505

Note this remote ERT module comes standard with 12-inch lead wires and may be shipped directly to the meter manufacturer for a factory-installed cable (interface). The interface cable must be purchased directly from the meter manufacturer.



CFG-0005-003

Remote Endpoint Mounting Kit



To connect the 100G Datalogging FN remote ERT module cable assembly to the rotary meter

Caution Verify the cable connector mates with the meter connector. Meter manufacturers use different connector styles (types).

1. Align the large lug on the 100G Datalogging FN remote ERT module connector with the large notch on the meter connector.

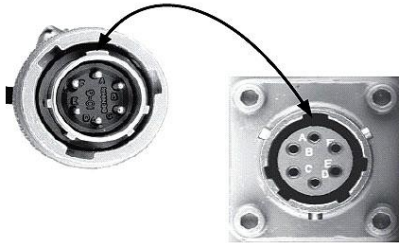

2. Align the lock ring notches on the module cable connector with the pins on the meter connector.

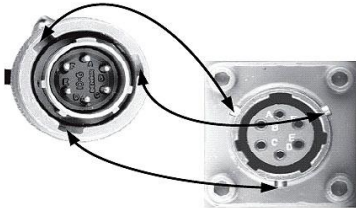

3. Hold the lock ring on the module connector back and push the plug into the meter connector until it is securely seated.
4. Turn the lock ring clockwise as far as it will go. You will feel it snap into place when it locks.



Warning To remove the module connector plug from the meter connector jack, push in on the lock ring, turn the lock ring counterclockwise as far as possible, and pull out the plug body. Do not pull on the module's connector cable.

5. Install the new Datalogging FN remote ERT module on the wall or a pipe using the Remote Endpoint Mount Kit (Itron part number CFG-0005-003). See [Mounting the 100G Datalogging FN Remote ERT Module](#) on page 6 for mounting instructions.



Programming the Remote ERT Module for Dresser ROOTS® Rotary Meters

To program 100G Datalogging FN remote ERT modules for use with Dresser ROOTS® rotary meters, use the meter drive rates from the drive rate table in this section.

B3, LMMA & S3A CTR/TC Meter Drive Rates for Remote ERT Module Programming



Caution Do not use these meter drive rates to program residential direct-drive or commercial direct-drive modules. Use the information in the following tables to program 100G Datalogging FN remote ERT modules connected to Dresser ROOTS® rotary meters..

B3, LMMA, S3A CTR/TC Meter Drive Rates			
B3 CTR Meter Size	B3 CTR Meter Pulse Rate	LMMA CTR Meter Size	LMMA CTR Meter Pulse Rate
8C	10	1.5M	10
11C	10	3M	10
15C	10	5M	10
2M	10	7M	10
3M	10	11M	10
5M	10	16M	100
7M	10	23M	100
11M	10	38M	100
16M	100	56M	100
23M	100	102M	100
38M	100		
56M	100		
LMMA CTR Meter Size	LMMA CTR Meter Pulse Rate	LMMA TC Meter Size	LMMA TC Meter Pulse Rate
1.5M	10	1.5M	10
3M	10	3M	10
5M	10	5M	10
7M	10	7M	10
11M	10	11M	10
16M	100	16M	100
23M	100		
38M	100		
56M	100		
102M	100		

Meters built 1/99 and beyond		Meters built prior to 1/99	
B3 TC Meter Size	B3 TC Meter Pulse Rate	B3 TC Meter Size	B3 TC Meter Pulse Rate
8C	10	8C	50
11C	10	11C	50
15C	10	15C	50
2M	10	2M	50
3M	10	3M	50
5M	10	5M	50
7M	10	7M	50
11M	10	11M	50
16M	100	16M	500
S3A CTR Meter Size	S3A CTR Meter Pulse Rate	S3A TC Meter Size	S3A TC Meter Pulse Rate
1.5M	10	1.5M	10
3M	10	3M	10
5M	10	5M	10
7M	10	7M	10
11M	10	11M	10
16M	100	16M	100

Installing the Remote ERT Module to the Elster American Meter RPM Series Rotary Meter

Some meter manufacturers provide ERT mounting kits and installation procedures for their meters. If the 100G Datalogging FN remote ERT module to Elster American RPM meter installation instructions are not available, follow the installation procedure in this section.



Elster American Meter RPM Series Rotary Meter

To install the 100G Datalogging FN remote ERT module on an Elster American RPM series meter

1. Remove the meter's top plate by removing the two 5mm screws and carefully prying up on the plate. The plate is secured with an o-ring seal. Remove the o-ring from the plate.

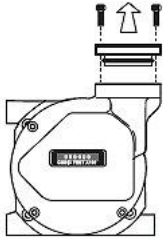

Caution If the o-ring is damaged during removal, obtain a replacement from Elster American Meter Co.

2. Look into the meter tower and find the meter switch lead and connector (4-pin).

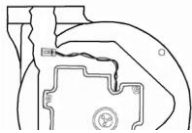

3. If the lead and connector are not visible or cannot be found, remove the four 5mm mounting screws and the register cover. The meter switch lead and connector will be visible inside the cover.

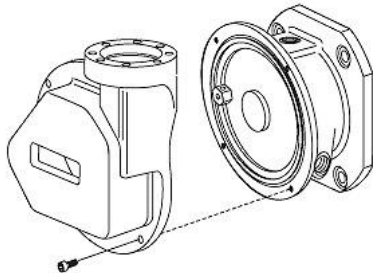

4. Feed the lead and connector into the register cover tower.

Note Save any meter tags. You will re-install them later in the installation process.

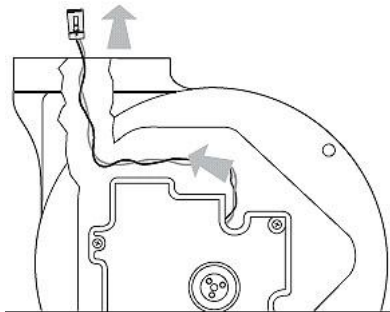

5. If you removed the register cover, replace the cover using the four (4) 5mm mounting screws.

6. Attach the 4-pin male connector on the Elster American Meter adapter plate to the 4-pin female connector inside the meter's tower. The connectors will slide together and latch.

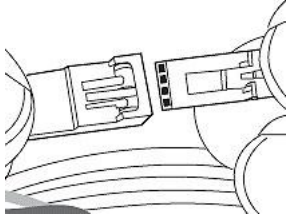

7. Carefully push the connectors and wires into the meter tower housing.

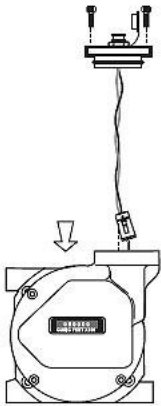

8. Lubricate the o-ring with o-ring lubricant and install the o-ring on the adapter plate. Insert the adapter plate into the tower and tighten the two 5 mm screws.

To connect the manufacturer cable to the ERT module

Note Connection to an Elster American Meter requires a cable interface compatible to an Elster American Meter RPM rotary meter.

1. Trim the ERT module wires to 3.5-inches.

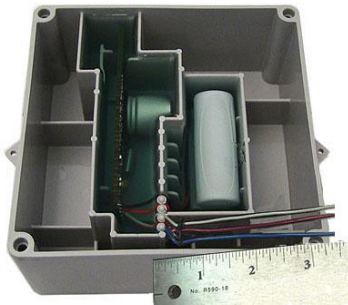

2. Carefully strip the insulation covering from the meter cable (purchased from the meter manufacturer) approximately 1-1/2-inches from the end.

Caution Do not cut through the individual wire insulation.

3. Separate the black, white, and blue wires for connection to the Datalogging FN remote ERT module. Cut off the unused wires even with the outer covering (insulation).

Caution Do not strip the individual wires.

- Connect the meter cable to the 100G Datalogging FN remote ERT module using 3M gel-cap connectors. Follow the wire connection table and wiring diagrams below. See [Installation Prerequisites](#) on page 5 for appropriate 3M crimping tools.

Important Use a crimping tool compatible with gel-connectors. *Do not* use a standard pliers for crimping gel-connects. The crimping tool provides an even pressured crimp to make a secure connection. Apply pressure for three seconds until the gel cap is fully crimped (collapsed) to allow time for the low viscosity silicone-based gel to flow. If the silicone gel flows out of the crimped connector, avoid touching the gel. Gel flowing from the connector provides environmental protection for the connection.

American RPM Meter to Datalogging FN remote ERT module Wire Connections

American RPM Meter wire	100G Datalogging FN remote mount ERT module wire
Red	Red
White	White
Black	Blue

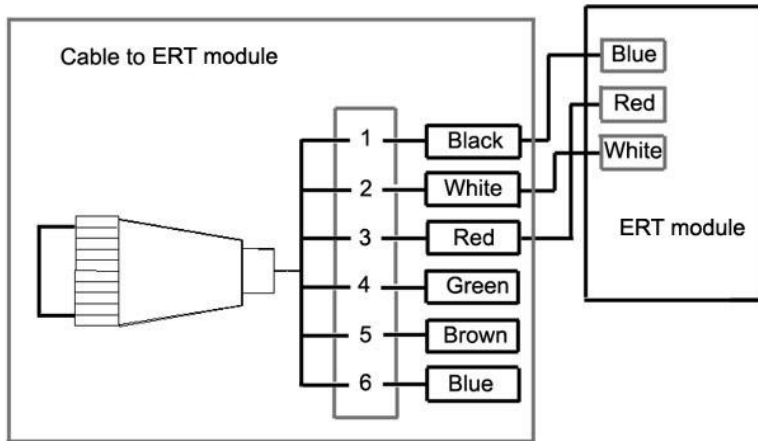
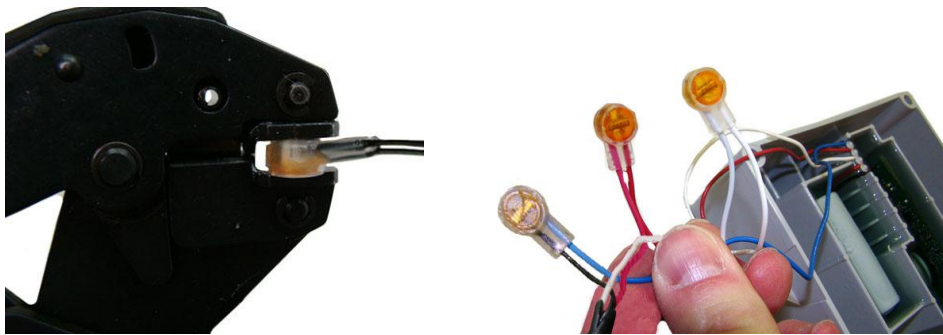

5. Insert the meter cable through the slot on the ERT module backplate. Install a cable tie to the meter cable wire below the meter cable insulation to provide strain relief.

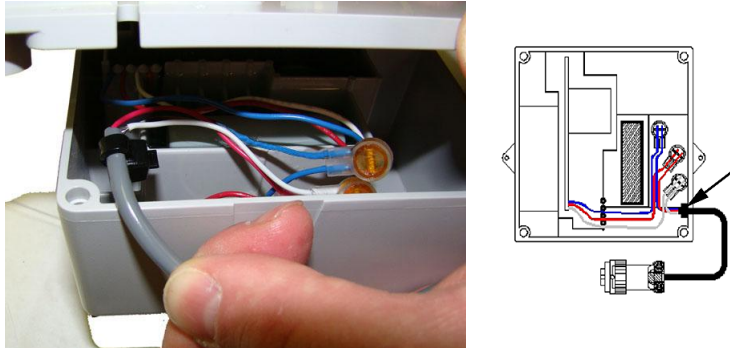

6. Tuck the connectors and cable tie into the ERT module housing. Place backplate on the assembly and tighten the four backplate screws using a size T-10 Torx screwdriver.

Important Verify the cable tie and gel connectors are inside the module housing and the cable extends out of the slot in the backplate. Torque the backplate mounting screws to 9-12 inch-pounds.



To install the Datalogging FN remote ERT module cable

1. Insert the plug on the cable connected to the ERT module into the receptacle on the meter adapter plate.

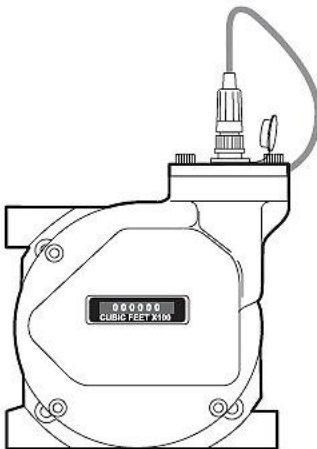

2. Tighten the threaded collar on the plug onto the American Meter interface receptacle. Verify the connection is hand-tight.

Mounting the 100G Datalogging FN Remote Mount ERT Module

Select an appropriate mounting location on adjacent piping close to the meter. Using the pipe bracket, mounting plate and band clamps from the Remote Mount Kit (Itron part number CFG-0005-003), secure the 100G Datalogging FN remote ERT module. Use the cable ties from the kit to secure any excess wire to the piping (see [Mounting the 100G Datalogging FN Remote ERT Module on a Pipe](#) on page 7).



Installing the Remote ERT Module to the Romet Electronically Compensated Meter (ECM2®)



The Romet ECM2® meter has three Form A outputs that can be configured at the factory to provide any combination of the following three outputs:

- Uncorrected volume (UNC VOL)
- Corrected volume (COR VOL)
- Alarm

The pulse weight for the volumetric outputs is configured in *Setup Mode* at **Menu items > SET UNC OUT** and **Menu items > SET COR OUT**. Since Setup Mode is fully configurable, the ECM2® module is universally adaptable to all Romet TC meter bodies. Reference the Romet technical manual for specific details on the ECM2®.

Connecting the ERT Module to the Romet ECM2® Meter

Connect the correct interface wirings and set the output pulse spacing to complete 100G Datalogging FN remote ERT module installation with the Romet ECM2® meter. See the ECM2® Interface Wiring Table below to complete wire connections.

Function		(+)UC	(-)UC	(+)CC	(-)CC	(+)ALM	(-)ALM	(+)Aux.CC	(-)Aux.CC
ERT Module wire		White and Blue	Red	White and Blue	Red	White and Blue	Red	White and Blue	Red
Pin location for Cannon Connector Part Number	34-125-20	C	B	A	B	E	D		
	34-125-40	A	B	C	D	E	F		
	34-125-41	A	B	C	D	E	F		
	34-125-42	E	F	A	B	C	D		
	34-125-43			A	B	E	F	C	D
	34-125-44							A	B
	34-125-45	A	B	E	D	C	F		
	34-125-50	3	1	2	5	6	4		
	34-125-51	3	1	2	5			6	4



Caution Set the ECM2® output pulse spacing to 750ms for operation with the 100G Datalogging FN remote ERT module. Output spacing represents an *off-time* between pulses.

Romet ECM2 Mounting Requirement

This mounting procedure requires the Romet ECM2/ERT Mounting Kit (Romet part number 34-444-1-KIT).

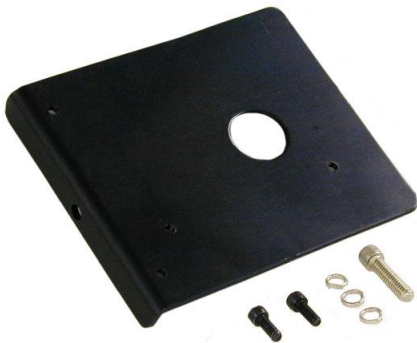

To mount the 100G Datalogging FN remote ERT module on the Romet ECM2 meter

1. Remove the module screw from the back of the ECM2 meter and discard.



2. Insert the mounting screw fitted with the three lock washers. Two lock washers are used as spacers as shown.

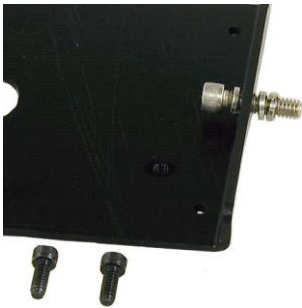

3. Attach the mounting plate to the meter. Insert the mounting screw where the module screw was removed. Torque the mounting screw to 5-7 ft.lbs. to secure the plate to the Romet meter.



4. Mount the 100G Datalogging FN remote ERT module using the pre-drilled holes on the mounting plate and the module mounting screws.
5. Place new tamper seals over the two screws. Press tamper seals into place using an 11/32-inch nut driver or similar blunt tool.

6. Connect the module to the meter using the previously installed cable interface.



Programming the 100G Datalogging FN Remote ERT Module



Caution You must program the 100G Datalogging FN remote ERT module before use. Follow the steps in this section to properly program the ERT module.

Program the 100G Datalogging FN remote ERT modules using:

- A FC200SR handheld computer with Endpoint-Link® or Endpoint-Link Pro version 5.3 or higher or Field Deployment Manager (FDM) software version 1.1 or higher
or
- A FC300 with SRead handheld computer with Endpoint-Link or Endpoint-Link Pro version 5.5 or higher or Field Deployment Manager (FDM) software version 1.1 or higher
or
- A 900MHz Belt Clip Radio with Endpoint-Link version 5.5 or higher or Field Deployment Manager (FDM) software version 1.1 or higher and a customer-supplied laptop. The Belt Clip Radio connects to the user-supplied laptop using a USB cable or Bluetooth.
- See the *Endpoint-Link v5.3* (or higher) *Endpoint Programming Guide* (TDC-0744) or the *Field Deployment Manager Endpoint Tools Mobile Application Guide* (TDC-0934) for more complete programming information.



FC200SR

FC300 with SRead

900MHz Belt Clip Radio

To program the 100G Datalogging FN remote ERT module

1. Program the meter drive rate into the 100G Datalogging FN remote ERT module using a handheld computer or Belt Clip Radio and laptop computer. For all programming and **Check Endpoint** operations using a handheld computer, hold the handheld as close to vertical as possible. For best success, keep the handheld within six feet of the target ERT module. Verify you have the correct programming mode (Fixed Network Mode, Mobile High Power Mode, Mobile/Handheld Mode, or Hard to Read Mobile/Handheld Mode) for your application. Programming parameters are based on the configuration file loaded into the programming device. During programming, the 100G Datalogging FN remote ERT module is set to the nearest 100 cubic feet; the last two digits (tens and units) are programmed as zeros (0). After programming is complete, the ERT module assembly will read to the nearest cubic foot.
2. **Read** or **Check** the 100G Datalogging FN remote ERT module using the handheld computer or Belt Clip Radio.
 - If the read result is higher than the number programmed in step 1, the 100G Datalogging FN remote ERT module is counting correctly.
 - If the read result is not higher than the number programmed in step 1, replace the 100G Datalogging FN remote ERT module.

CHAPTER 4

Electronic Volume Corrector and Instrument Installation

This section provides the instructions to install the 100G Datalogging FN remote ERT module on:

- Mercury Instruments Mini-P, Mini-AT, Mini-Max, and EC-AT
- Mercury Instruments Temperature Compensated Indexes (TCI)
- Dresser ROOTS IMC/W2 and MC2 Micro Correctors



Mini-AT



Mini-Max



EC-AT



TCI



IMC/W2



MC2

Installation Prerequisites

100G Datalogging FN remote ERT module installation to a volume corrector or instrument requires:

- 100G Datalogging FN remote ERT module compatible to a volume corrector or instrument (see the [100G Datalogging FN Remote ERT Module Meter Compatibility List](#) on page 3).
- Volume corrector or instrument compatible with the remote ERT module.
- Proper tools and devices for installation and programming (see [Installation Prerequisites](#) on page 5).



Installation Overview

Installing the 100G Datalogging FN remote ERT module to a volume corrector or instrument involves five tasks:

1. Programming the Mercury Instrument (see [Programming the Mercury Instrument](#) on page 34 or reference the Mercury Instrument Programming Guide for more information).
2. Installing Mercury retrofit parts (if necessary).
3. Attaching the Datalogging FN remote ERT module to a pipe or vertical flat surface (wall) (see [Mounting the 100G Datalogging FN Remote ERT Module](#)).
4. Connecting the Datalogging FN remote ERT module on page 6 to the Mercury Instrument Volume Corrector (see [To wire the ERT Module to the Mercury Instrument](#) on page 37), Mercury Instrument Temperature Compensating Index (TCI), or Dresser ROOTS Micro Corrector (IMC/W2 or MC2).
5. Programming the Datalogging FN remote ERT module (see [Programming the 100G Datalogging FN Remote ERT Module](#) on page 30).

Programming the Mercury Instrument

Code Settings

Volume Instrument Type	Item Code Settings and Corresponding Terminal Board Channel											Terminal Board Connections*
	Pulse Output Options	Channel A		Channel B		Channel C		Number of Blanked digits on CorVol Display	Pulse Output Spacing			
		#056	#93	#057	#094	#058	#095		#96	#115	#1014	#1015
ECAT	Pulse Board Ver-1(3) Form-C	n/a	n/a	n/a	n/a	n/a	n/a	n/a	n/a	n/a	n/a	Module does not support a Form-C pulse output board.
	Pulse Board Ver-2(3) Form-A	2.0000	0	2.0000	0	2.0000	0	1, 2, 3, or 4	1, 2, 3, or 4	n/a	n/a	Ka, Kb, Kc (Red Wire) Ya, Yb, Yc (Blue & White Wire) Connection must be on same terminal board channel (for example, Ka/Ya; Kb/Yb; Kc/Yc).
	Pulse Board Ver-3(2) Form-C1 Form-A	n/a	n/a	n/a	n/a	2.0000	0	1, 2, 3, or 4	1, 2, 3, or 4	n/a	n/a	Kc (Red Wire) Y (Blue & White Wire). For this option, module must be connected to Channel C.
Mini with Form A Mainboard	Main Board Type-2	2.0000	0	n/a	n/a	n/a	n/a	1, 2, 3, or 4	1, 2, 3, or 4	n/a	n/a	K (Red Wire) Y (Blue & White Wire). For optional SPA Bd., jumper must be installed on J1-B as indicated in the Mercury Quick Reference Guide (page 148) for Form A.
Mini-AT	JB29, JB30 & JB31 Jumpered for Form-A	2.0000	0	2.0000	0	n/a	n/a	1, 2, 3, or 4	1, 2, 3, or 4	n/a	n/a	K (Red Wire) Y (Blue & White Wire). For optional SPA Bd., jumper must be installed on J1-B as indicated in the Mercury Quick Reference Guide (page 148) for Form-A.
	JB29, JB30 & JB31 Jumpered for Form-C	n/a	n/a	n/a	n/a	n/a	n/a	n/a	n/a	n/a	n/a	Module does not support a Form-C pulse output board.
Mini-Max	All Main Boards	2	0	2	0	n/a	n/a	1, 2, 3, or 4	1, 2, or 4	n/a	n/a	K (Red Wire) Ya or Yb (Blue & White Wire)
TCI	Form C Main Board	n/a	n/a	n/a	n/a	n/a	n/a	n/a	n/a	n/a	n/a	Module does not support a Form-C pulse output board.
	Form A Main Board	2.0000	0	2.0000	0	n/a	n/a	1, 2, 3, or 4 blanks (7, 6, 5, or 4 active)	n/a	<i>Iron</i> selection in dropdown menu.	<i>Iron</i> selection in dropdown menu.	Connections to channels of output pulses are made through loose unterminated cable wires and gel connect connectors.

Notes:

- Code 0 for items 093, 094 & 095 = Corrected Volume Pulse Data
- Code 1 for item 115 = 1.000 Sec.
- Code 2 for item 115 = 2.000 Sec.
- Code 1 for item 096 = blank 1 digit and display 7 digits
- Code 2 for item 096 = blank 2 digits and display 6 digits
- Code 3 for item 096 = blank 3 digits and display 5 digits
- Code 4 for item 096 = blank 4 digits and display 4 digits

*For more information, see pages 11-20 of the "Basic Pulse Information for Mercury Instruments, Inc., Electronic Volume Correctors" manual, or contact Mercury Instruments at 513-272-1111.

Mercury Instrument programming parameters:



Caution A Mercury Instrument must have a Form A board. A Form C board is not compatible with the 100G Datalogging FN remote ERT module.

For TCI, when using both outputs, items 1014 and 1015 must be set to *ltron*.

- Item #056: Pulse A Scaling. Set at 2.0000 for a form A switch.
- Item #057: Pulse A Scaling. Set at 2.0000 for a form A switch.
- Item #058: Pulse A Scaling. Set at 2.0000 for a form A switch.
- Item #090: Corrected Volume Units: Code (0-20) selects the unit of measure for Corrected Volume (Item000) and other "CorrVol" related items.
- Item #092: Uncorrected Volume Units: Code (0-20) selects the unit of measure for Uncorrected Volume (Item002) and other "UncVol" related items.
- Item # 093, 094, 095: Type of gas volume information to be sent. For "CorrVol" selected, must be set at 0.
- Item # 096: Corrected Volume Display: Must be set at 1, 2, 3 or 4 blanks. Module does not support a setting of 0 blanks.
- Item # 097: Uncorrected Volume Display: Must be set at 1, 2, 3, or 4 blanks. Module does not support a setting of blanks.
- Item # 098: Check drive rate of the corrector. Should be the same as the plate above the uncorrected dials and the same as the plate on the index drive of the meter.
- Item # 115: Output Pulse Code: Must be set at 1 or 2.

Wiring the ERT Module to the Instrument

Use the terminal strip connector (Phoenix connector) in the Mercury Instrument to connect the 100G Datalogging FN remote ERT module to the instrument.



Note In Mercury Instrument EC-AT correctors, the connector may be soldered to the pulse board.

The 100G Datalogging FN remote ERT module has three lead wires (red, white, and blue). The red wire is attached according to Mercury Instrument Code Settings (see [Code Settings](#) on page 35).



The blue and white wires are twisted together and attached according to Mercury Instrument's Code Settings (see [Code Settings](#) on page 35).

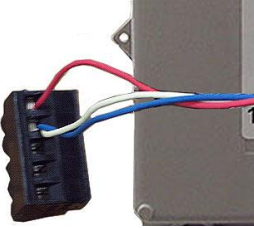

To wire the ERT module to the Mercury Instrument

1. Insert the ERT module cable into the instrument's compression connector.



2. Strip one inch of the outer insulation from the 100G Datalogging FN remote ERT module. Strip 1/4-inch individual wire insulation from the red, white, and blue lead wires.

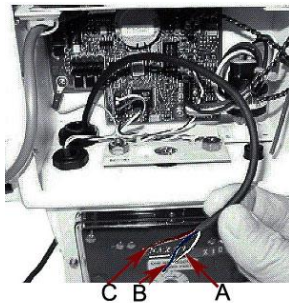

- A White wire
- B Blue wire
- C Red wire

Caution Keep wires away from the rotating magnetic spindle in the Mercury Instrument.

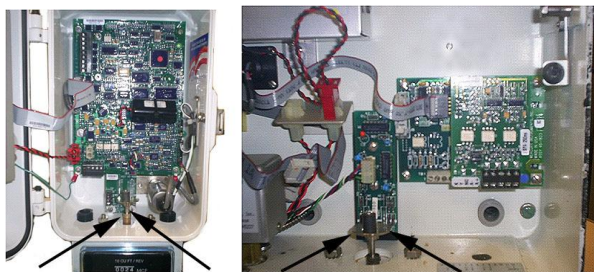

3. See [Mounting the 100G Datalogging FN Remote ERT Module](#) on page 6 for module mounting instructions.

Wiring Dual ERT Modules to a Mercury Instrument

This section includes the information to wire dual ERT modules to a single Mercury Instrument. Installation requires the correct programming parameters (see [Code Settings](#) on page 35).

With Itron 100G Datalogging FN remote ERT modules, utilities can receive *corrected* and *uncorrected* consumption values by installing two endpoints. The ERT module for *corrected* reads is attached to the corrector's pulse output. The ERT module for *uncorrected* reads is attached to the input switch board. The *corrected* pulse output is programmable; the *uncorrected* pulse output is dependent on the connected meter's drive rate.



Important Some Mercury Instruments have two pulse outputs so the *uncorrected* pulse output could be connected to the additional output, but the connection should be to the input switch board in case the corrector battery fails. Counts will be collected if the *uncorrected* pulse is connected to the switch board since the board is not dependent on battery power.



Dual Remote ERT Modules Mounted on a Mercury Instrument

To install dual 100G Datalogging FN remote ERT modules to a Mercury Instrument Mini-Max Case Volume Corrector using Mercury Kit 22-1077

1. Place the Mercury Instrument volume corrector in *shutdown* condition and disconnect all power from the Mini-Max main board.
2. Remove the battery pack from the volume corrector and set it aside.
3. Remove the four screws from the main board and the board from the enclosure. Set the board aside.
4. Remove the two hex screws from the input switchboard and the switchboard from the enclosure and set it aside. You will re-install the switchboard later.

Warning The battery pack, main board and switchboard may be damaged if left in the Mercury Instrument volume corrector while completing this installation.

5. Drill two 3/16-inch holes in the back of the Mini-Max enclosure as specified by the information included in the kit. Remove any metal shavings from the enclosure.
6. Clean the 100G Datalogging FN remote ERT modules with the alcohol wipe where you will place the Corrected and Uncorrected labels (included in the kit).

Note Clean the Datalogging FN remote ERT modules with the alcohol wipe to ensure good label adhesion.

7. Mount the module for *corrected* pulse outputs on the left bracket mounting space. Insert three #8-32 x 1/2-inch screws in a triangular pattern. Install the top screw so the head of the screw is approximately 1/8-inch from the Endpoint Mounting Bracket surface. Slide the module onto the screw so the mounting lug fits securely onto the screw. If necessary, remove the module and make any necessary adjustment to the screw depth to ensure a secure fit. Install the two bottom screws in an alternating fashion.
8. Mount the module for *uncorrected* pulse outputs on the right bracket mounting space. Insert three #8-32 x 1/2-inch screws in a triangular pattern. Install the top screw so the head of the screw is approximately 1/8-inch from the Endpoint Mounting Bracket surface. Slide the endpoint onto the screw so the mounting lug fits securely onto the screw. If necessary, remove the module and make any necessary adjustment to the screw depth to ensure a secure fit. Install the two bottom screws in an alternating fashion.
9. Route the module cables under the bracket edge and toward the rear of the Mercury Instrument.
10. Mount the Endpoint Mounting Bracket (Mercury Instrument part number 22-1077, included in the kit) onto the Mini-Max enclosure. Place a #8 metal flat washer followed by a rubber sealing washer onto both #8-32 x 3/8" screws. Align the lower threaded holes in the mounting bracket with the drilled enclosure holes and insert a screw/washer through the enclosure housing. Screws heads must be inside the enclosure. Tighten both screws using a screwdriver.

Note Aligning the second bracket threaded hole and drilled hole may require some manipulation of the mounting bracket.

11. Insert the module cables (both units) through the large cable strain relief on the left rear of the instrument's enclosure. Leave a one-half to one inch drip loop under the cable strain relief.
12. Secure three cable ties on the module cables in three places on the cables as specified by information included in the kit.
13. Re-install the input switchboard, main board, and battery pack removed in step 2.
14. Connect the *corrected* module wires to TB1 on the Mini-Max board following the table below. Use Mercury upgrade kit 40-2678-1 to provide the second pulse output channel for the uncorrected ERT module.

Corrected ERT Module Connections

ERT Module	Mini-Max TB1
Red wire	K terminal
Blue wire*	Ya terminal
White wire*	Ya terminal

*Twist the blue and white endpoint wires together before connecting to the Mini-Max board.

Tighten terminal connections securely.

15. Connect the *uncorrected* module wires to the Input Switch Board UNC. VOL following the table below.

Uncorrected ERT Module Connections

ERT Module	Mini-Max Input Switch Board UNC. Vol.
Red wire	COM terminal
Blue wire*	NO terminal
White wire*	NO terminal

*Twist the blue and white ERT module wires together before connecting to the Mini-Max board.

Tighten terminal connections securely.

16. Tighten the large strain relief securely.

Warning Do not crush the endpoint through-cables when tightening the strain relief.

17. Re-install or reconnect the power or battery sources.

18. Close the instrument case and tighten the case screw securely. Replace any locks that were removed for installation.

Wiring the Remote ERT Module to the Mercury TCI

The Mercury Instruments Temperature Compensating Index (TCI) provides two Form-A volume pulse outputs and one Form-B alarm output. These outputs are electronic switches. The first two pulse outputs are configurable for compensated or uncompensated volume. The third output (Form-B) is for alarm output use only.



Connections to the three output pulse channels are completed using loose unterminated wires (the individual wires from a cable) and gel-connectors. The TCI unit has six unterminated wires and six gel-connectors (Itron part number CON-0023-001) to enable pulse connections to ancillary devices. Loose wires are located inside the gray adapter plate behind the black strain relief fitting.



Adapter plate with black strain relief Loose cable wires

The three switch contacts on the TCI PC board are MOSFET output type opto-isolators that provide high voltage isolation between the sensitive processor components of the TCI board and the outside world.

Wire Color	Description	Function
Orange	Volume output channel A	Comp/uncomp volume pulse
Yellow	Volume output channel A	(configurable pulse timing)
White	Volume output channel B	Comp/uncomp volume pulse
Green	Volume Output channel B	(configurable pulse timing)
Brown	Alarm channel	Alarm event signal
Blue	Alarm channel	(Pulse timing)

To make TCI pulse connections

Note Connect one ERT module/channel to the alarm output if the modules are used on channels A and B.

1. Remove strain relief fitting by unscrewing from the gray adapter plate.



Note Do not remove the fitting's hex nut. Un-screw the entire fitting from the gray adapter plate. A tether line is secured to the strain relief fitting. When the strain relief fitting is removed, the tether line pulls the unterminated wires out of the adapter plate for access to the loose wires.

2. Loosen the strain relief fitting hex nut and remove the white plug from the center.

- Place the strain relief fitting onto the field pulse cable.



- If the field pulse cable is smaller than a 0.2-inch diameter, install the rubber tube supplied with the TCI onto the cable so the strain relief will clamp onto the tube after it is re-installed.



- Connect the individual external pulse cable conductors to the un-terminated wires following *Configuration for two endpoints connected to one TCI*. Insert one un-terminated wire into an opening of a gel-connector (six gel-connectors were included with the TCI). Insert the appropriate field cable wire into the other gel-connector opening.

Configuration for two ERT modules connected to one TCI

Channel A

ERG-500x-503	TCI
White	Orange and brown
Red	Yellow
Blue	Blue (alarm)

Channel B

ERG-500x-503	TCI
White	White
Red	Green
Blue	White

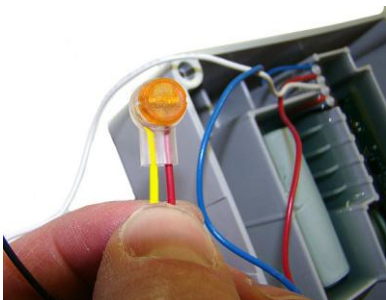

6. Verify both wires are fully inserted into the gel-connector prior to crimping.

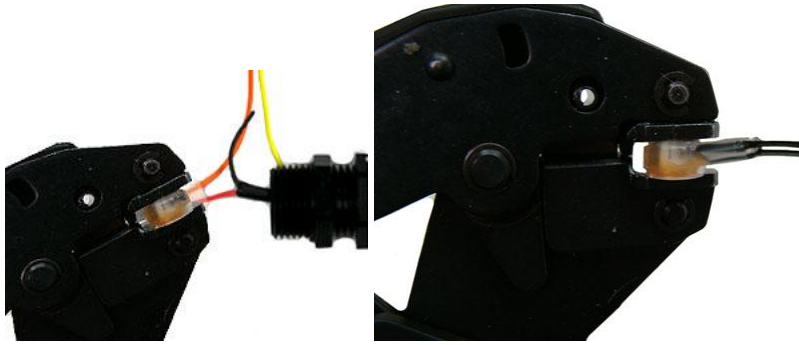

Important Use a crimping tool compatible with gel-connectors. *Do not* use a standard pliers for crimping gel-connects. The crimping tool provides an even pressured crimp to make a secure connection. Apply pressure for three seconds until the gel cap is fully crimped (collapsed) to allow time for the low viscosity silicone-based gel to flow. If the silicone gel flows out of the crimped connector, avoid touching the gel. Gel flowing from the connector provides environmental protection for the connection.

7. Insert the gel-connected wires into the threaded gray adapter plate hole.



8. Replace the strain relief and tighten until secure.

Connecting the 100G Datalogging FN Remote Mount ERT Module to the IMC/W2 or MC2 Cable

You may ship the Itron 100G Datalogging FN remote ERT module directly to Dresser ROOTS® Meters for a factory-installed cable. If you connect the ERT module to the meter using an existing cable purchased from Dresser ROOTS®, complete the following cable installation procedure.

-  **Caution** The purchased cable must have a mating connector compatible with the IMC/W2 or MC2 receptacle. Dresser ROOTS® cables may be wired in different configurations for specific applications. If necessary, contact Dresser ROOTS® Meters for wiring diagrams for your specific application.

To connect the 100G Datalogging FN remote ERT module to the IMC/W2 or MC2 cable

1. Remove the backplate (4 screws) from the 100G Datalogging FN remote ERT module and expose the module lead wires. The backplate and screws will be re-installed on the module later in this procedure so store them (temporarily) in a safe, secure place.

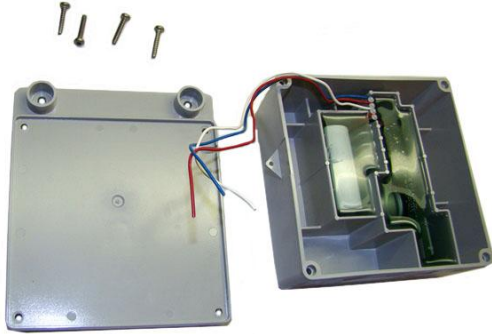

2. Insert the lead wires from the 100G Datalogging FN remote ERT module into new 3M gel connectors (Itron part number CON-0023-001) together with the same colored lead wire from the meter cable (see the wiring table below) and crimp using a 3M hand-held crimping tool.

Important Use a crimping tool compatible with gel-connectors. *Do not* use a standard pliers for crimping gel-connects. The crimping tool provides an even pressured crimp to make a secure connection. Apply pressure for three seconds until the gel cap is fully crimped (collapsed) to allow time for the low viscosity silicone-based gel to flow. If the silicone gel flows out of the crimped connector, avoid touching the gel. Gel flowing from the connector provides environmental protection for the connection.

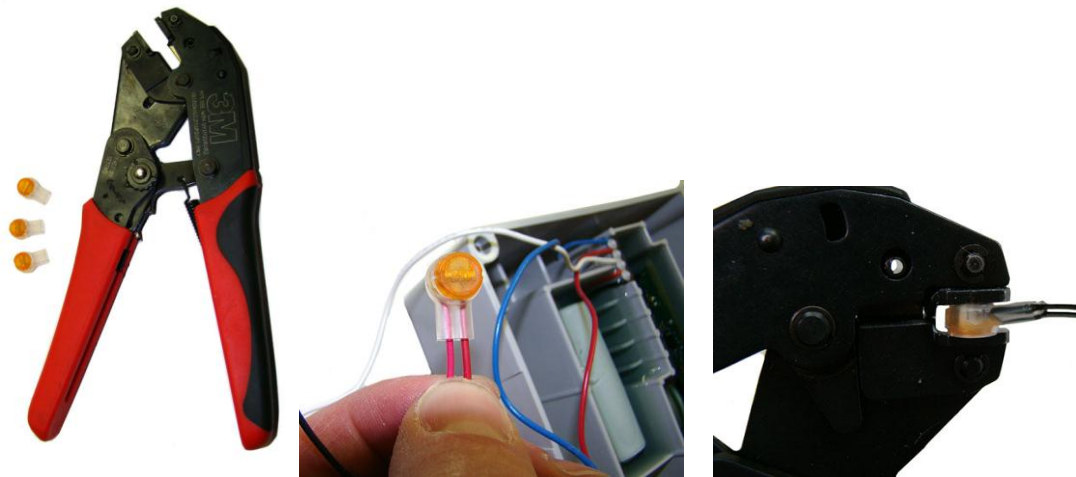

Note Do not strip lead wire prior to inserting the wire in the gel connector.

IMCW2 to Remote ERT Module Wire Table

IMCW2 Wire	Remote Module wire
Red	Red
White	White
Blue	Blue