

DRAFT



Knowledge to Shape Your Future

Natural Gas Solutions

100G Installation Guide for Mercury Electronic Volume Correctors

Revision A3



Putting knowledge to work.

DRAFT

Identification

100G Remote ERT Module Installation Guide
Part number: PUB-0200-002 Revision A 02/08
ERT Part Numbers: ERG-5000-502 (100G with 5-ft. cable)

Copyright

© 2008 Itron, Inc. All rights reserved.

Your company has the right to reproduce this contract document, provided that such reproduction shall be subject to the same use and disclosure restrictions contained in the Confidentiality and Non-Disclosure paragraphs in the Sales Contract.

Applicable Patents

U.S. Patent Numbers: TBD
Canadian Patent Numbers: TBD

Transportation Classification

The Federal Aviation Administration prohibits operating transmitters and receivers on all commercial aircraft. When powered, the 100G Remote ERT Module is considered an operating transmitter and receiver and cannot be shipped by air. All product returns must be shipped by ground transportation.



WARNING! Only authorized Itron personnel should attempt repairs on Itron equipment. Attempts to do so by others might void any maintenance contract with your company. Unauthorized service personnel might also be subject to shock hazard on some Itron equipment if removal of protective covers is attempted.



WARNING! Substitution of components may impair intrinsic safety.



WARNING! To prevent ignition of flammable or combustible atmospheres, disconnect power before servicing.

Compliance Statement

This device complies with Part 15 of the FCC Rules. Operation of this device is subject to the following two conditions:

- This device may not cause harmful interference.
- This device must accept any interference that may cause undesirable operation.

This device must be permanently mounted such that it retains a distance of 20 centimeters (7.9 inches) from all persons in order to comply with FCC RF exposure levels.

Modification and Repairs

To ensure FCC compliance and system performance, this device and antenna shall not be changed or modified without the expressed approval of Itron. Any unauthorized modification will void the user's authority to operate the equipment.

Meter Installation/Removal

In the event of malfunction, all repairs should be performed by Itron. It is the responsibility of users requiring service to report the need for service to Itron.



WARNING! Follow these procedures to avoid injury to yourself or others.

- The lithium battery may cause a fire or chemical burn if it is not disposed of properly.
- Do not recharge, disassemble, heat, or incinerate the lithium battery.
- Keep the lithium battery away from children.

Related Documents

Endpoint-Link Endpoint Programming Guide (TDC-0744)

Trademark Notice

Enscan, ERT, Itron, ReadOne, and Endpoint-Link are registered trademarks of Itron, Inc. All other product names and logos in this documentation are used for identification purposes only and may be trademarks or registered trademarks of their respective companies.

Suggestions

If you have comments or suggestions on how we may improve this documentation, send them to TechnicalCommunicationsManager@itron.com.

If you have questions or comments about this application, contact Itron Technical Support:

Itron, Inc.

- Mail: Itron, Inc. Attention: Customer Care, 2111 N Molter Road, Liberty Lake, WA 99019
- E-mail: support@itron.com
- Phone: 1 800 635 8725

DRAFT

Contents

Chapter 1 Getting Started	1
Tools and Materials Supplied By You	1
Materials Supplied by Itron.....	2
Screw Specifications.....	3
Code Settings.....	3
Chapter 2 Installing the 100G Remote ERT Module	7
Mount the Corrector	7
Pipe Mounting	8
Adapter Plate Mounting Positions.....	12
Program the ERT	15
Flat Surface Mounting	22
Program the ERT	25
Functional Specifications.....	30
Physical Specifications.....	31
Operational Specifications.....	31

DRAFT

DRAFT

CHAPTER 1

Getting Started

The 100G is Itron's latest gas encoder-receiver-transmitter (ERT®) module.

ERT modules are radio-frequency (RF) devices that transmit meter data. The RF meter data can be received by a reading device that is within transmission distance of the ERT. Itron's 100G ERT module has increased output power over legacy gas ERT modules for increased RF transmission distance.

This installation guide shows you how to install the 100G Remote ERT Module on the Mercor Mini, Mini-AT, Mini-Max, and EC-AT meter correctors.

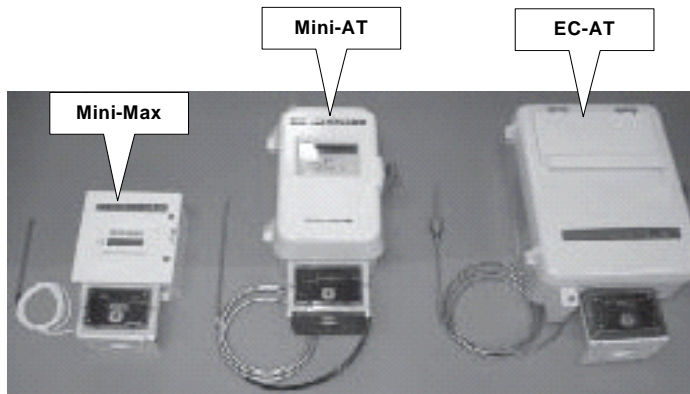

Tools and Materials Supplied By You

You must supply the following tools and material to install, program, and check the 100G Remote ERT Module:

- Medium flat-blade screwdriver for band clamps
- Small flat-blade screwdriver for installing Phoenix connector
- Medium flat-blade, torque-measuring screwdriver for the screws used to attach adapter plates to pipe brackets and the screws used to attach ERT modules to adapter plates. Torque to be measured is 9 to 12 inch-pounds
- Medium Philips screwdriver for opening and closing Mini-Max cover, and, if necessary, for attaching ERT modules to flat surfaces
- Pliers for pulling cable ties tight
- 1" wrench for tightening compression connector nut
- Side-cutting pliers ("dykes") or similar tool for cutting off the excess length of cable tie straps
- 1/4-inch nut driver or other blunt tool for seating ERT-module tamper seals
- Rubber tape for sealing compression connector

- FC200R unit for programming and checking ERT modules.

Materials Supplied by Itron

The following items are supplied with each 100G Remote ERT Module installation:

- 100G Remote ERT Module with 5-foot cable (ERG-5000-502)



- A pipe bracket installation kit

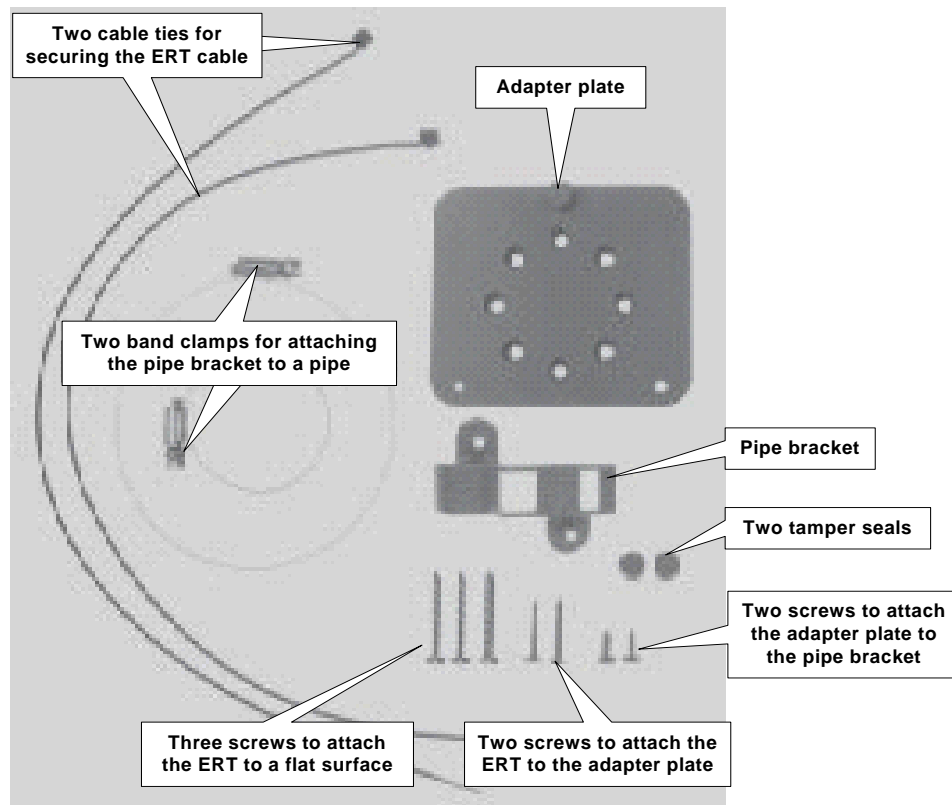

Screw Specifications

For mounting adapter plates on pipe brackets

8–15 x 1/2 Type A slotted pan head tapping screw, corrosion resistant steel

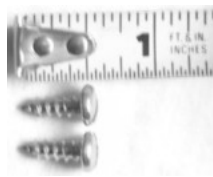

For mounting ERTs on adapter plates

8–15 x 1 Type A slotted panhead tapping screw, corrosion resistant steel

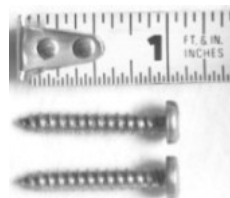

For mounting ERTs on wood or sheet metal surfaces

10–16 x 1 1/2 Type AB Phillips panhead tapping screw, corrosion resistant steel



Code Settings

Instrument Type	Item Code Settings and Corresponding Terminal Board Channel									Terminal Board Connections*
	Form A	Channel A		Channel B		Channel C				
		#056	#093	#057	#094	#058	#095	#096	#115	
ECAT:	0	n/a	n/a	n/a	n/a	n/a	n/a	n/a	n/a	ERT does not support a Form-C Pulse Output Board
	3	2.0000	0	2.0000	0	2.0000	0	1, 2, 3 or 4	1 or 2	Ka, Kb, Kc (Red Wire) Ya, Yb, Yc (Blue & White Wire). Connection must be on same terminal board channel (i.e., Ka/Ya; Kb/Yb; Kc/Yc).
	1	n/a	n/a	n/a	n/a	2.0000	0	1, 2, 3 or 4	1 or 2	Kc (Red Wire) Yc (Blue & White Wire) For this option, ERT must be connected to Channel C.
Mini with Form A Mainboard:	1	2.0000	0	n/a	n/a	n/a	n/a	1, 2, 3 or 4	1 or 2	K (Red Wire) Y (Blue & White Wire) Jumper settings must be on J1-B as stated in the Mercury Quick Reference Guide (page 45) for Form-A.
Mini-AT:	2	2.0000	0	2.0000	0	n/a	n/a	1, 2, 3 or 4	1 or 2	K (Red Wire) Y (Blue & White Wire) Jumper settings must be on J1-B as stated in the Mercury Quick Reference Guide (page 45) for Form-A.
	0	n/a	n/a	n/a	n/a	n/a	n/a	n/a	n/a	ERT does not support a Form-C Pulse Output Board
Mini-Max:	2	2.0000	0	2.0000	0	n/a	n/a	1, 2, 3 or 4	1 or 2	K (Red Wire) Ya OR Yb (Blue & White Wire)

* For more information, see pages 11-20 of the "Basic Pulse Information for Mercury Instruments, Inc., Electronic Volume Correctors" manual, or contact Mercury Instruments at 513-272-1111.

DRAFT

DRAFT

DRAFT

DRAFT

CHAPTER 2

Installing the 100G Remote ERT Module

The 100G Remote ERT Module can be mounted on a pipe, using the pipe bracket installation kit, or a flat surface. The 100G Remote ERT Module must always be mounted with the printed label right-side-up, and the encoder wires and tamper seals at the bottom, as shown.



Mount the Corrector

Mount the corrector on the meter according to the Mercury installation manual.

Enter the specified code settings for the corrector.

Pipe Mounting

To mount the adapter plate on vertical a pipe

1. Get the pipe bracket from remote mount kit and a proper size band clamp.



2. Loosen the clamp screw until the end of the band is released.

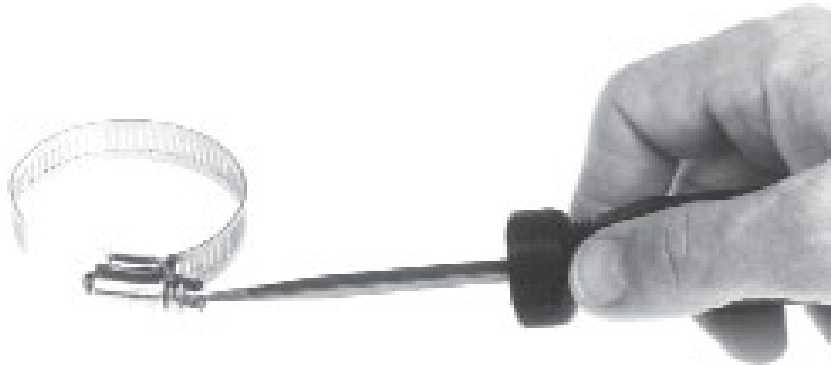

3. Push the end of the band through this hole in the pipe bracket.

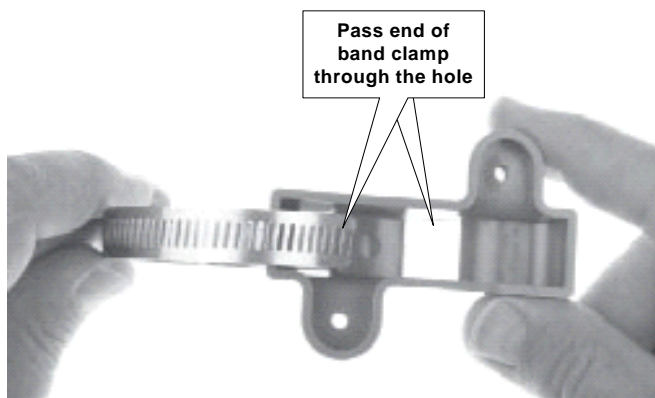

4. Place the band clamp around the pipe.
5. Push the end of the band through the hole in the band clamp and into the entrance to the screw assembly.

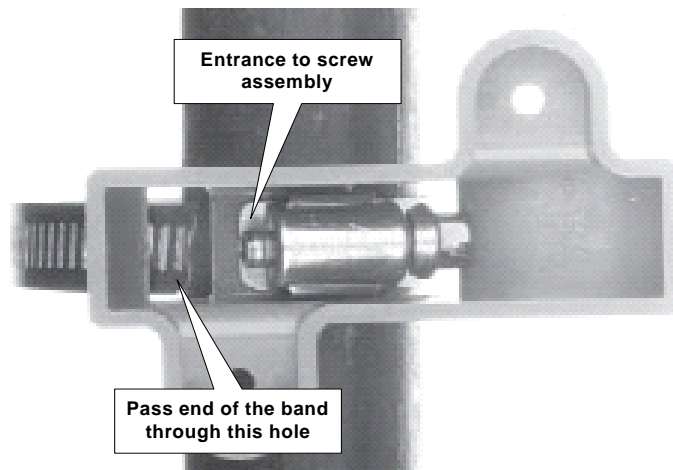

6. Tighten the band clamp until the end of the band can be pushed into the hole in the pipe bracket.

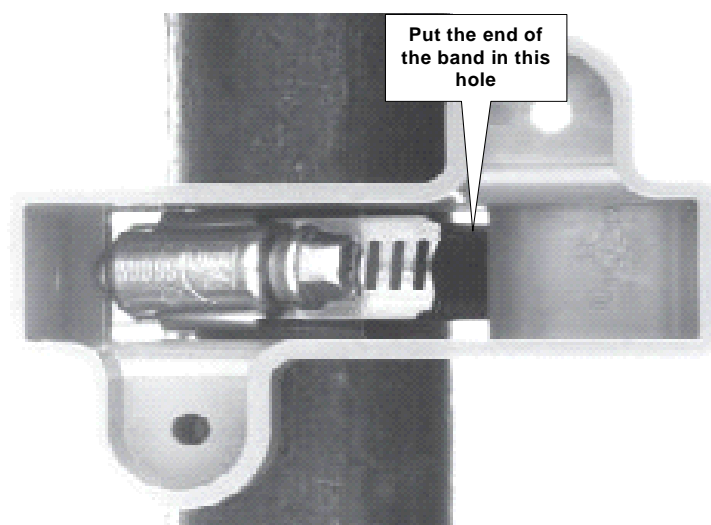

DRAFT

7. Tighten the clamp screw three or four more turns to make sure the end of the band does not pop back out on this side of the pipe bracket.
8. Position the band clamp as shown then fully tighten the band clamp screw.

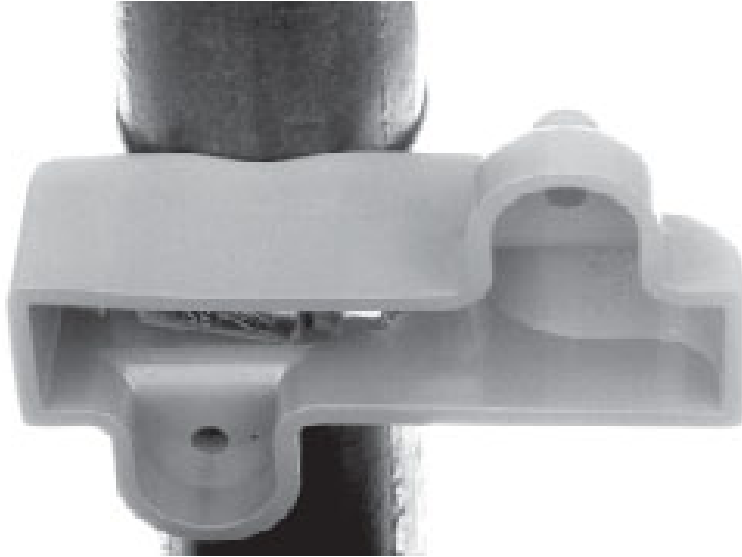

9. Place the adapter plate on the pipe bracket. The adapter-plate screw boss goes into this pipe-bracket recess.

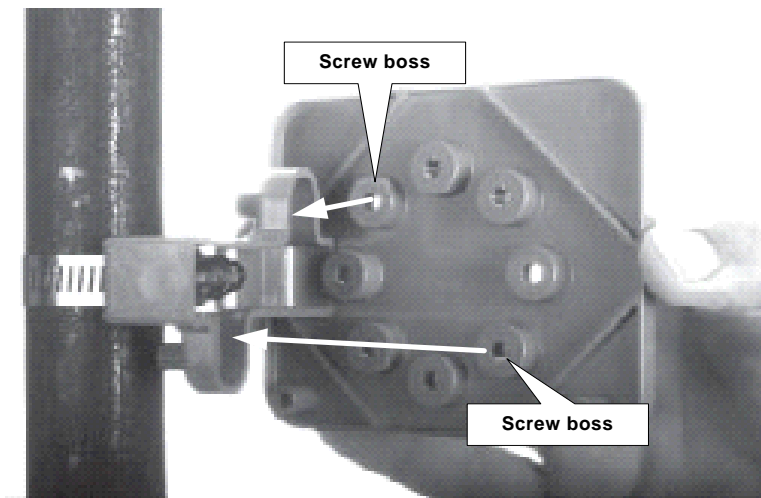

When the adapter plate is properly positioned on the pipe bracket, it looks like this.



10. Obtain two adapter-plate mounting screws (shown here actual size) from the installation kit.

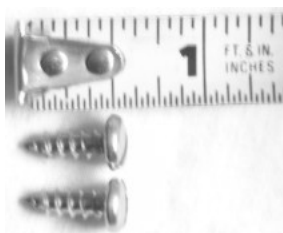

11. Install the adapter plate mounting screws in these holes.

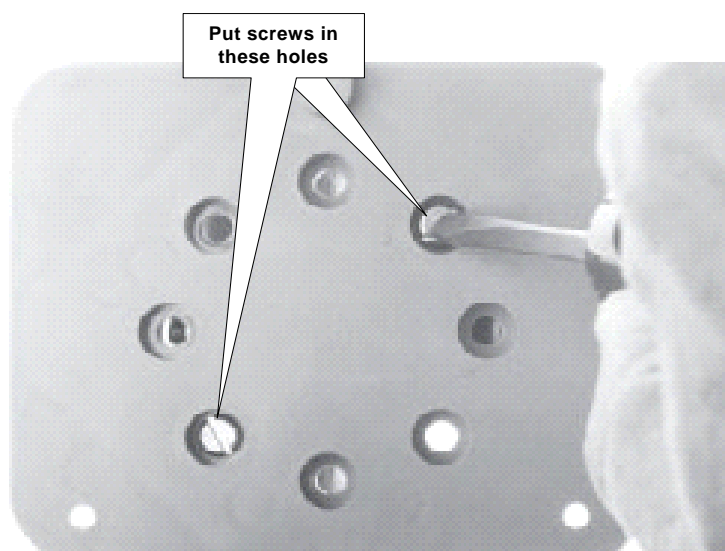

12. Tighten both screws to 9 to 12 inch-pounds of torque.

Adapter Plate Mounting Positions

The installation procedure in this section shows how to mount the adapter plate on vertical pipes. The following pictures show how to mounting the adapter plate on pipes that are either horizontal or at 45 degree angles. Regardless of which direction the pipe goes, the adapter plate mounting lug must always be at the top.

If the pipe is at a 45 degrees angle up to the right, install the adapter plate as shown.

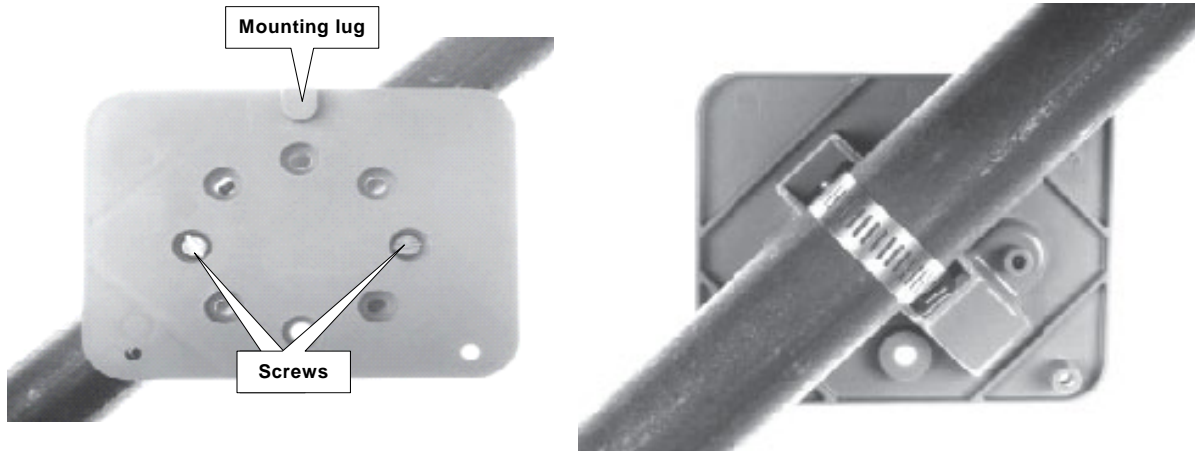

If the pipe is at a 45 degrees angle up to the left, install the adapter plate as shown.

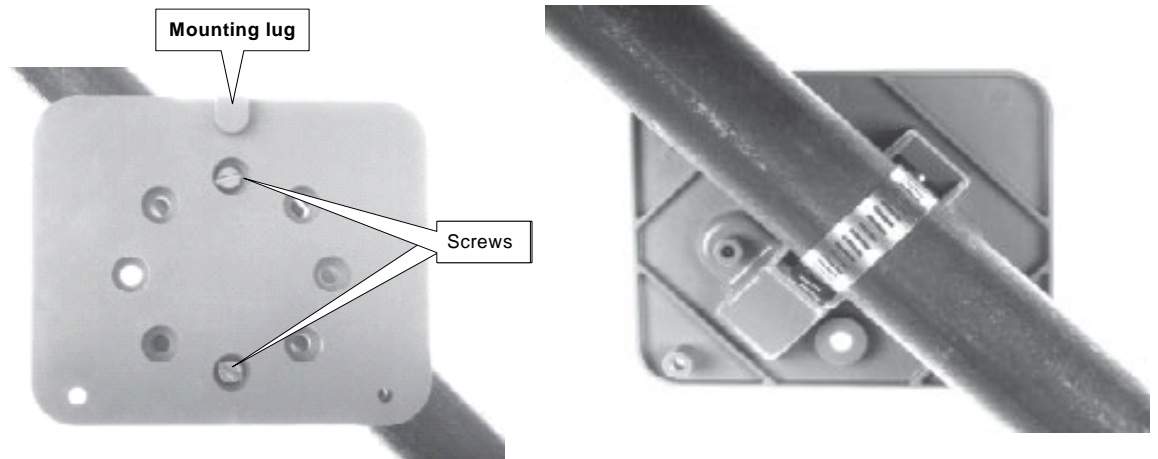

If the pipe is horizontal, install the adapter plate as shown.

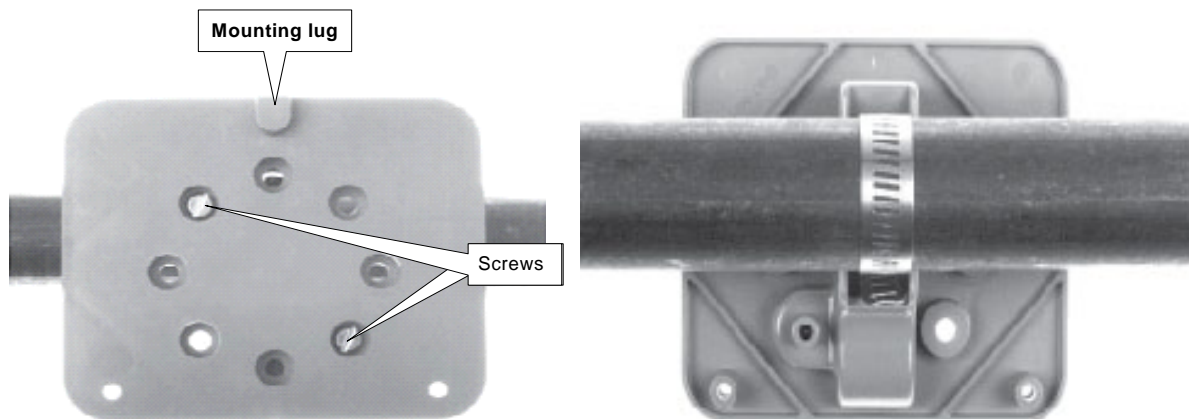

To mount the 100G Remote ERT Module on the adapter plate

1. Get the 100G Remote ERT Module and two 1-inch mounting screws from the installation kit.
2. Place the back of the ERT module against the face of the adapter plate.



DRAFT

The adapter-plate mounting lug should be just above the ERT-module mounting lug recess.

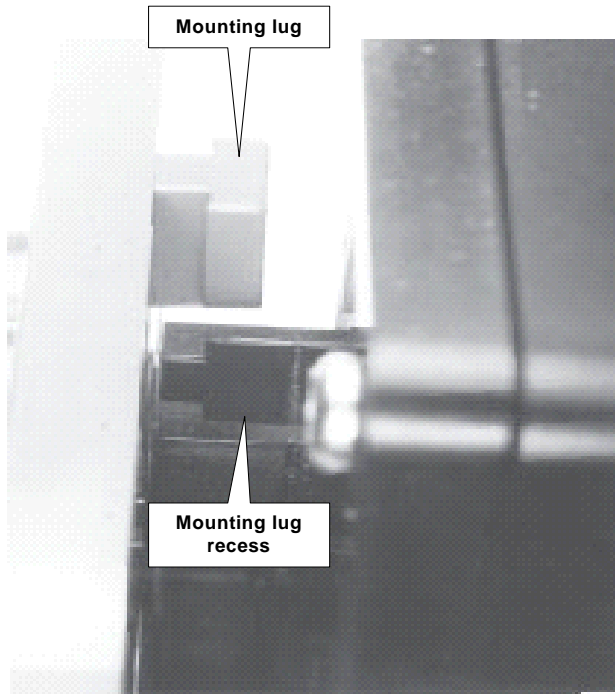

3. Raise the ERT module until the adapter-plate mounting lug is as far as possible inside the ERT-module mounting lug recess.



4. Install the two ERT module mounting screws you got from the installation kit.

When the ERT module is properly mounted on the adapter plate, it should look like this.



5. Tighten the screws to 9 to 12 inch-pounds of torque.

Program the ERT

The ERT must be programmed using the FC200SR with EndPoint-Link software. See the *Endpoint-Link ERT Programming Guide (TDC-0411)* for more information.



IMPORTANT You must perform the following programming procedure for the ERT module to function properly.

When programming the ERT module, you must take note of the drive rate shown on the index of the meter. Program the meter based on the drive rate shown on the index.

To program the ERT module

1. Using the FC200SR, program the reading of the index that was on the meter into the ERT module assembly.
 - For initial programming, hold the FC200SR approximately 1 foot away from the 100G.
 - For reprogramming (30 days or more past initial programming), hold the FC200SR approximately 4 to 5 feet away from the 100G.

Be sure to program the 100G to the correct mode for the reading technology that will be used (for example, Fixed Network Mode, Mobile/Handheld Mode, or Hard to Read Mobile/Handheld Mode). In Endpoint-Link Pro v5.0, you will have access to the one mode that was defined by your system administrator.

2. Read the ERT module assembly using the FC200SR. Consult the *EndPoint-Link ERT Programming Guide (TDC-0411)* or other applicable instructions for details on how to read an ERT.
 - If this reading is higher than the one you programmed in step 1 above, the ERT module assembly is counting correctly.
 - If the ERT module assembly reading is *not* higher than what was programmed in step 1, replace the ERT module with a new one.

To connect the ERT cable to the corrector

1. Insert the ERT cable into the compression connector.



2. Strip one inch from the outer insulation and about 1/4-inch from the red, white and blue wires. Twist the blue and white wires together.



3. Install the Phoenix connector (supplied by Mercury). Connect the red, blue and white wires to the Phoenix connector terminals as directed in [Code Settings](#) on page 3.



NOTE In EC-AT units, the connector might be soldered to the pulse board.

DRAFT

4. Install the connector so that the "K" terminal is topmost, leaving some slack in the cable.

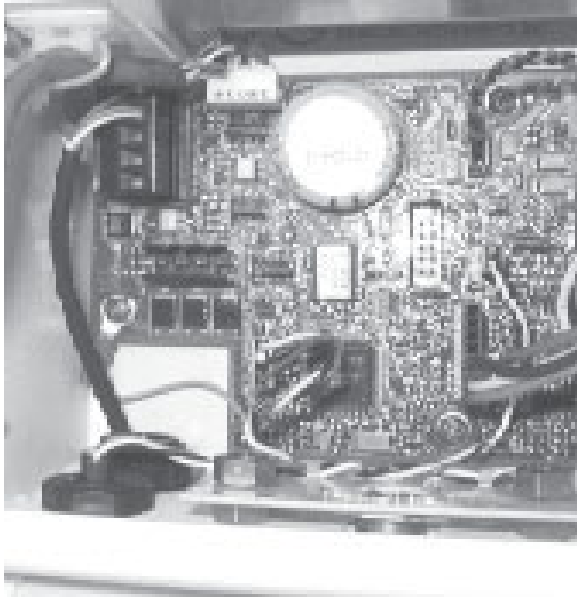

5. To hold the cable in place, wrap and stretch some rubber tape at the compression connector.



6. Install and tighten compression nut. This provides strain relief and seals the connection.



To install tamper seals and cable ties

1. Get two new tamper seals from the installation Kit.
2. Place a new tamper seal over each ERT module mounting screw.



DRAFT

3. Push both tamper seals all the way into place with a 1/4-inch nut driver or similar tool.



The 100G Remote ERT Module should look like this after the tamper seals have been installed.



4. Loop a cable tie around the pipe and the ERT cable.

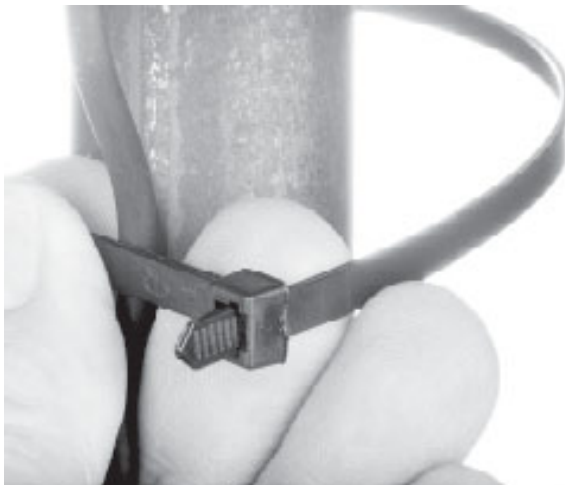

5. Pull the cable tie tight and cut off excess length. Dispose of the cut-off piece properly.

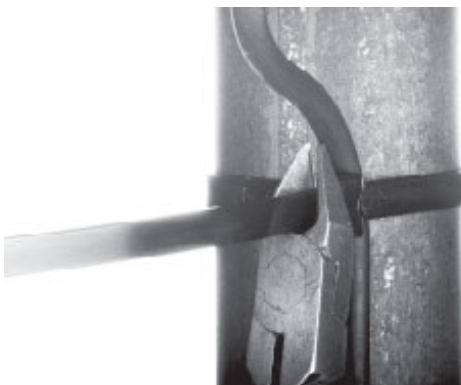

When finished, the cable tie should look like this.



DRAFT

6. Push any excess wire up between the back of the ERT module and the face of the adapter plate.



Flat Surface Mounting

To mount the 100G Remote ERT Module on a flat surface

1. Drill three pilot holes in the mounting surface the proper size for the mounting screws, as shown in the drilling template.



WARNING! Do not strike electrical wires or damage anything on the other side of the surface you are going to mount the ERT module on when you drill the holes and install the screws.

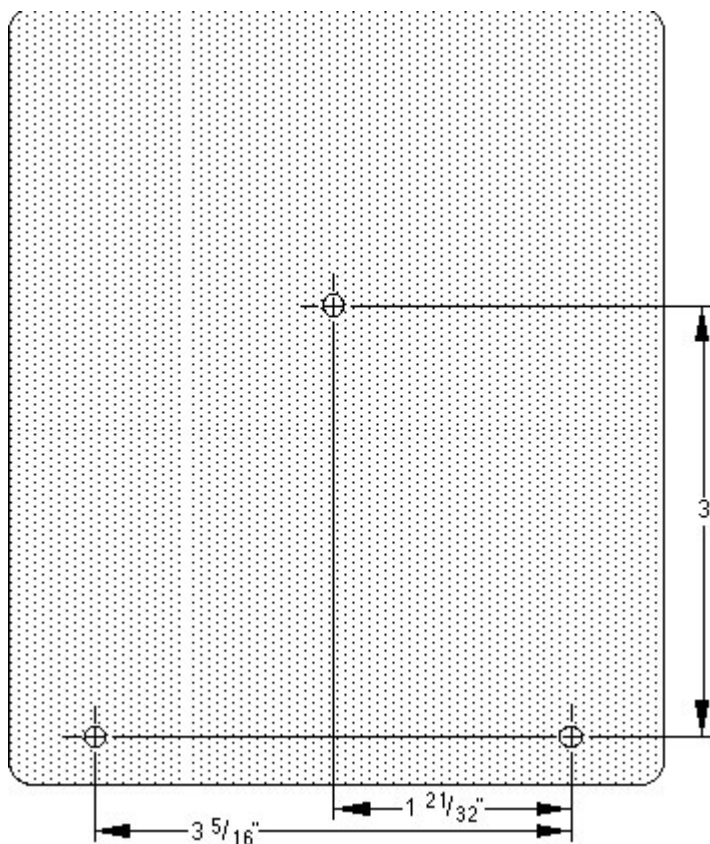

The holes for the bottom two screws must be on a horizontal line.

If you mount the ERT module on a wood surface, use the mounting screws included with the ERT module or screws with the same size heads.

2. Get the three 1 1/2 inch mounting screws from the installation kit.
3. Turn the top mounting screw part way into the mounting surface.



DRAFT

4. Get an ERT module assembly.
5. Turn the screw into the mounting surface until the back side of the ERT module mounting lug recess at the top of the ERT module will just barely slide under the screw head.

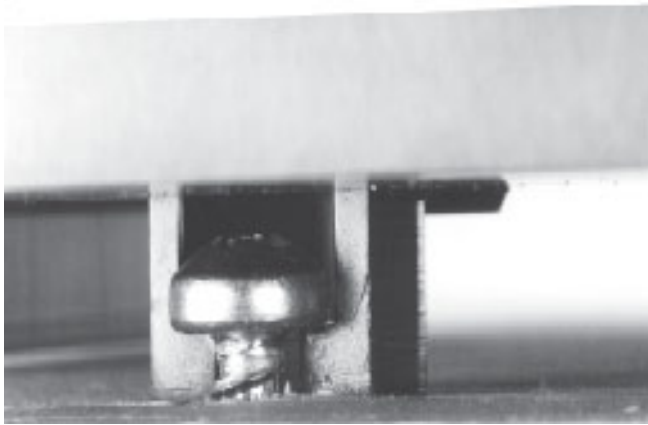

6. Push the ERT module upward until the screw head is all the way into the screw-head mounting recess at the top of the ERT module.

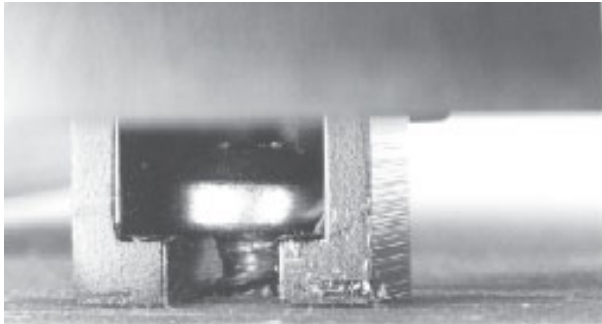

7. Install and fully tighten the two bottom ERT module mounting screws.



Program the ERT

The ERT must be programmed using the FC200SR with EndPoint-Link software. See the *Endpoint-Link ERT Programming Guide (TDC-0411)* for more information.



IMPORTANT You must perform the following programming procedure for the ERT module to function properly.

When programming the ERT module, you must take note of the drive rate shown on the index of the meter. Program the meter based on the drive rate shown on the index.

To program the ERT module

1. Using the FC200SR, program the reading of the index that was on the meter into the ERT module assembly.
 - For initial programming, hold the FC200SR approximately 1 foot away from the 100G.
 - For reprogramming (30 days or more past initial programming), hold the FC200SR approximately 4 to 5 feet away from the 100G.

Be sure to program the 100G to the correct mode for the reading technology that will be used (for example, Fixed Network Mode, Mobile/Handheld Mode, or Hard to Read Mobile/Handheld Mode). In Endpoint-Link Pro v5.0, you will have access to the one mode that was defined by your system administrator.

DRAFT

2. Read the ERT module assembly using the FC200SR. Consult the *EndPoint-Link ERT Programming Guide (TDC-0411)* or other applicable instructions for details on how to read an ERT.
 - If this reading is higher than the one you programmed in step 1 above, the ERT module assembly is counting correctly.
 - If the ERT module assembly reading is *not* higher than what was programmed in step 1, replace the ERT module with a new one.

To connect the ERT cable to the corrector

1. Insert the ERT cable into the compression connector.



2. Strip one inch from the outer insulation and about 1/4-inch from the red, white and blue wires. Twist the blue and white wires together.

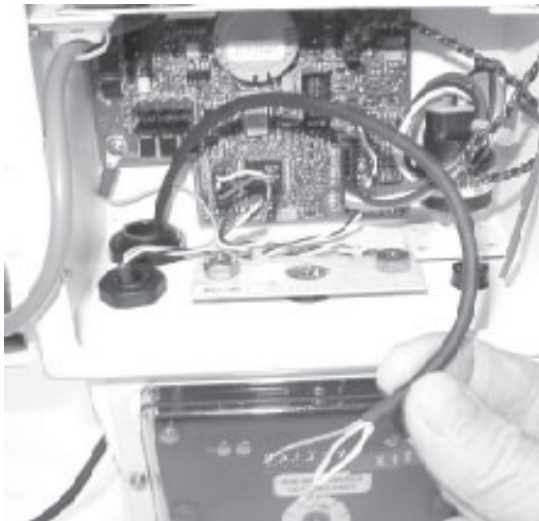

3. Install the Phoenix connector (supplied by Mercury). Connect the red, blue and white wires to the Phoenix connector terminals as directed in [Code Settings](#) on page 3.



NOTE In EC-AT units, the connector might be soldered to the pulse board.

4. Install the connector so that the "K" terminal is topmost, leaving some slack in the cable.

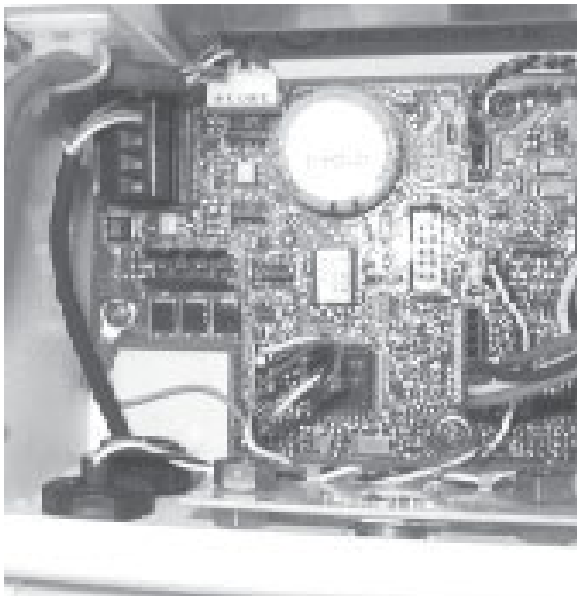

DRAFT

5. To hold the cable in place, wrap and stretch some rubber tape at the compression connector.



6. Install and tighten compression nut. This provides strain relief and seals the connection.



To install tamper seals and cable ties

1. Get two new tamper seals from the installation kit.
2. Place a new tamper seal over each ERT module mounting screw and push both seals all the way into place with a 1/4-inch nut driver or similar tool.



3. Secure extra cable with a cable tie.



DRAFT

4. Pull the cable tie tight and cut off excess length. Dispose of the cut-off piece properly.



When finished, the tamper seals and cable should look like this.



Functional Specifications

Power source: Lithium battery

Radio programming parameters: LCD reading, number of digits, count rate, security level

Mercury corrector programming parameters:

- Correctors must have Form A board. Form C is NOT supported.
- Item # 056: Pulse A Scaling. Set at 2.0000 for a form A switch.
- Item #057: Pulse A Scaling. Set at 2.0000 for a form A switch.
- Item #058: Pulse A Scaling. Set at 2.0000 for a form A switch.

- Item # 093: Type of gas volume information to be sent. For CorVol selected, must be set at 0.
- Item # 094: Type of gas volume information to be sent. For CorVol selected, must be set at 0.
- Item # 095: Type of gas volume information to be sent. For CorVol selected, must be set at 0
- Item # 096: Corrected Volume Display: Must be set at 1, 2, 3 or 4 blanks. ERT does not support a setting of 0 blanks.
- Item # 115: Output Pulse Code: Must be set at 1 or 2.

Operating temperatures: -40°F to + 158°F (-40°C to +70°C)

Operating humidity: 5 to 95 percent non-condensing relative humidity

Product identification: Numeric and bar-coded ERT module type and serial number

FCC compliance: Part 15 certified

Intrinsically safe per: Factory Mutual and UL Class 1, Division 1, Groups C and D

Physical Specifications

Materials of construction: Black polycarbonate housing; encapsulated electronics

Operational Specifications

Receive frequency: 952 and 956 MHz (MAS Bands)

Transmit frequency: 910 to 920 MHz

Data integrity: Verified in every data message

DRAFT