



Knowledge to Shape Your Future

Natural Gas Solutions

2.4GZ OpenWay Gas Module Installation Guide - Remote Mount

Identification

2.4GZ OpenWay Gas Module Installation Guide - Remote Mount
09/17/2010 TDC-0838-001

2.4GZ OpenWay Gas Module part numbers: OWG-5001-501, OWG-5001-502, OWG-5001-503, OWG-5001-504
OWG-5002-501, OWG-5002-502, OWG-5002-503, OWG-5002-504

Copyright

© 2010 Itron, Inc. All rights reserved.

Confidentiality Notice

The information contained herein is proprietary and confidential and is provided subject to the condition that (i) it is held in confidence except to the extent required otherwise by law and (ii) it is used only for the purposes described herein. Any third party given access to this information is similarly bound in writing.

Trademark Notice

Itron is a registered trademark of Itron, Inc.

All other product names and logos in this documentation are used for identification purposes only and may be trademarks or registered trademarks of their respective companies.

Safety Approvals

Intrinsically safe per UL Class I, Division 1, Groups C & D

Applicable Patents

U.S. Patent Numbers: 4,614,945; 4,753,169; 4,768,903; 4,799,059; 4,867,700

Canadian Patent Numbers: 1,254,949; 1,267,936; 1,282,118

Compliance Statement

This device complies with Part 15 of the FCC Rules. These limits are designed to provide reasonable protection against harmful interference in a residential installation. Operation is subject to the following two conditions:

- This device may not cause harmful interference.
- This device must accept any interference that may cause undesirable operation.

This device must be permanently mounted such that it retains a distance of 20 centimeters (7.9 inches) from all persons in order to comply with FCC RF exposure levels.

Compliance Statement

This equipment has been tested and found to comply with the limits, pursuant to Part 15 of the FCC Rules. These limits are designed to provide reasonable protection against harmful interference in a residential installation. Operation is subject to the following conditions:

- This device may not cause interference.
- This device must accept any interference that may cause undesired operation of the device.

Compliance Statement

This equipment complies with policies RSS-210 and RSS-GEN of the Industry Canada rules.

Operation is subject to the following two conditions:

- (1) this device may not cause interference, and
- (2) this device must accept any interference, including interference that may cause undesired operation of the device.

Transportation Classification

The Federal Aviation Administration prohibits operating transmitters and receivers on all commercial aircraft. When powered, the 2.4GZ OpenWay remote mount gas module is considered an operating transmitter and receiver and cannot be shipped by air. All product returns must be shipped by ground transportation.

Modifications and Repairs

To ensure system performance, this device and antenna shall not be changed or modified without the expressed approval of Itron. Any unauthorized modification will void the user's authority to operate the equipment.

Meter Installation/Removal

In the event of malfunction, all repairs should be performed by Itron. It is the responsibility of users requiring service to report the need for service to Itron.



Warning To prevent ignition of flammable or combustible atmospheres, read, understand, and follow the manufacturer's live maintenance procedures.



Warning Follow these procedures to avoid injury to yourself or others:

- The lithium battery may cause a fire or chemical burn if it is not disposed of properly.
- Do not recharge, disassemble, heat above 100° Celsius (212° Fahrenheit), crush, expose to water, or incinerate the lithium battery. Fire, explosion, and severe burn hazard.
- Keep the lithium battery away from children.



Warning Only authorized Itron personnel should attempt repairs on Itron equipment. Attempts to do so by others might void any maintenance contract with your company. Unauthorized service personnel might also be subject to shock hazard on some Itron equipment if removal of protective covers is attempted.



Warning Substitution of components may impair intrinsic safety.

Suggestions

If you have comments or suggestions on how we may improve this documentation, send them to TechnicalCommunicationsManager@itron.com

If you have questions or comments about the software or hardware product, contact Itron Technical Support:

Contact

- Internet: www.itron.com
- E-mail: support@itron.com
- Phone: 1 877 487 6602

Contents

Before You Begin	iv
Document Conventions.....	iv
Chapter 1 2.4GZ OpenWay Remote Mount Gas Module Installation.....	1
Transmission Modes	1
Programming Modes	2
Specifications	3
Related Documents	3
2.4GZ OpenWay Remote Mount Gas Module Meter Compatibility List.....	3
Installation Prerequisites	7
Chapter 2 Mounting the 2.4GZ OpenWay Remote Mount Gas Module	8
Installation Options.....	8
Mounting Screw Specifications.....	8
Mounting Installation Considerations	9
Mounting the 2.4GZ OpenWay Remote Mount Gas Module on a Pipe	10
Mounting the Endpoint on a Wall or Other Flat Vertical Surface.....	16
Chapter 3 Rotary Meter Installation	19
Required Installation Materials Available from Itron.....	20
Connecting the 2.4GZ OpenWay Remote Mount Gas Module to the Rotary Meter Cable.....	20
Programming 2.4GZ OpenWay Remote Mount Gas Module for Dresser ROOTS® Rotary Meters .	24
B3, LMMA & S3A CTR/TC Meter Pulse Rates for Remote Module Programming	24
Installing the 2.4GZ OpenWay Remote Mount Gas Module to the Elster American Meter RPM Series Rotary Meter	25
Mounting the 2.4GZ Remote Mount Module	30
Installing the 2.4GZ OpenWay Remote Mount Gas Module to the Romet Electronically Compensated Meter (ECM2®)	30
Connecting the 2.4GZ OpenWay Remote Mount Gas Module to the Romet ECM2® Meter	31
Romet ECM2 Mounting Requirement.....	31
Programming the 2.4GZ OpenWay Remote Mount Gas Module Assembly	34

Chapter 4 Electronic Instrument Installation	36
Installation Prerequisites	37
Installation Overview	37
Programming the Mercury Instrument.....	38
Code Settings.....	38
Wiring the 2.4GZ OpenWay Remote Mount Gas Module to the Mercury Instrument.....	40
Wiring Dual Endpoints to a Mercury Instrument Corrector	42
Required Tools	42
Wiring the Remote Module to the Mercury TCI.....	44
Connecting the 2.4GZ Remote Gas Module to the Dresser ROOTS® IMC/W2 or MC2 Cable	48
Installing the Endpoint to the Dresser ROOTS® Micro Corrector (IMC/W2 or MC2)	51
Programming the 2.4GZ OpenWay Remote Mount Gas Module Assembly.....	55
Chapter 5 Diaphragm Meter Installation	57
Tools and Materials Supplied By You	57
Materials Available from Itron.....	58
Replacement Gaskets.....	58
Installing the 2.4GZ OpenWay Remote Mount Gas Module	59
Installing 2.4GZ OpenWay OpenWay Remote Mount Gas Module Encoders	60
Programming the OpenWay Remote Mount Gas Module Assembly.....	69
Chapter 6 Curb Diaphragm Meter Installation.....	71
Materials Available from Itron.....	71
Tools and Materials Supplied By You	72
Installing the 2.4GZ Remote Mount Gas Module on the Curb Meter.....	73
Programming the 2.4GZ OpenWay OpenWay Remote Mount Gas Module Assembly.....	81
Chapter 7 Dattus Meter Installation	83
Installation Prerequisites	83
Programming the Dattus Meter	83
Installation Overview.....	84
Installing the 2.4GZ Remote Mount Gas Module to Itron Dattus Meters	84
Direct Mounting the 2.4GZ OpenWay Remote Mount Gas Module to the Dattus Meter	85
Connecting the 2.4GZ OpenWay Remote Mount Gas Module to a Dattus meter	86
Mounting the 2.4GZ OpenWay Remote Mount Gas Module.....	87
Programming the 2.4GZ OpenWay Remote Mount Gas Module Assembly	87
Chapter 8 Sensus Sonix Meter Installation	90
Programming the Sensus Sonix Meter	90
Adjusting the Pulse Output for Sonix 600 and 880 Meters.....	90
Installing the 2.4GZ OpenWay Remote Mount Gas Module with Sensus Sonix Meters.....	91
Sensus Sonix2000 Pulse Output Wiring.....	91
Direct Mounting the 2.4GZ OpenWay Remote Mount Gas Module to the Sonix Meter	92
Connecting the 2.4GZ OpenWay Remote Mount Gas Module to a Sensus Sonix 600 or 880 Meter.....	93
Programming the 2.4GZ OpenWay Remote Mount Gas Module Assembly	94
Index	96

Before You Begin

Document Conventions

The following documentation conventions are used:



Caution A Caution warns the user that failure to heed the information in the note could result in loss of data. Be sure to carefully read a Caution note and follow the advice/instructions.



Warning A Warning alerts you of potential physical harm to the user or hardware. It is critical that you pay strict attention to WARNING notes, read the information carefully, and follow the advice/instructions.



Tip A Tip provides the user with extra hints/tips to make a task easier to perform or a concept easier to understand.



Note A Note supplies generic information to the user. The user can ignore the information and continue the task without suffering any adverse consequences.

2.4GZ OpenWay Remote Mount Gas Module Installation

2.4GZ OpenWay remote mount gas modules are radio-frequency (RF) devices operating over the 2.4 GHz frequency. The 2.4GZ OpenWay remote mount gas modules communicate with ZigBee®-compliant electric meters to transmit gas consumption data. Modules can store 40 days of hourly intervals and are programmed to bubble-up every 12 or 24 hours. Alternatively, the 2.4GZ OpenWay remote mount gas module can be awakened with an Itron magnet for programming or for binding to an OpenWay electric meter. When 2.4GZ OpenWay gas modules are installed alongside Itron OpenWay electric meters, the OpenWay solution for combo gas and electric utilities provides unprecedented management flexibility.

This installation guide provides step-by-step instructions to install the 2.4GZ OpenWay remote mount gas module on a wide variety of meters. 2.4GZ OpenWay remote mount gas module compatible meters are listed in the Meter Compatibility List.

Transmission Modes

The 2.4GZ OpenWay remote mount gas module can be set to transmit to Standard, Daily or Hourly Mode.

- **Standard Mode.** The 2.4GZ remote mount gas module transmits the current index read and Daily Freeze Time read; Daily Freeze Time read is programmable for any hour.
- **Daily Mode.** In addition to transmitting Standard Mode information, the 2.4GZ remote mount gas module transmits 40 days of daily interval data based on Daily Freeze Time reads.
- **Hourly Mode.** In addition to transmitting Standard Mode information, the 2.4GZ remote mount gas module transmits the last 24 hourly intervals.

Programming Modes

The 2.4GZ OpenWay gas module is programmed or reprogrammed to Normal, Sleep, or Doze Mode as defined in the configuration file. The table below describes these modes.

Mode	Description/Use Case	Radio	Metering (counting)	How to Enter this Mode	How to Exit this Mode
Normal	Normal Operating Mode. Used for Field Programming when electric meters are present or being installed.	On	On	Mag Swipe or Programmer	Programmer (can reprogram to any mode specified)
Sleep	For Shipping or Storage of modules Uses the least amount of battery current since the module does not communicate with the electric meter.	Off	Off	Programmer	Mag Swipe (to normal) or Programmer (to specified)
Snooze	Pre-program modules and deploy so they try to join the network automatically when they are installed in the field. The flow of gas or Mag Swipe triggers the module to change to Normal Mode.	Off	On	Programmer	Mag Swipe (to normal) Programmer (to specified) or Count Increment (to normal)
Doze	Pre-program meters in factory and deploy so they do not try to join the network when installed (for example, install gas before electric OR in factory counts will be added after programming and user does not want the radio turned on).	Off	On	Programmer	Mag Swipe (to normal) or Programmer (to specified)

Specifications

The following tables list the functional and operational specifications for the 2.4GZ OpenWay remote mount gas module.

Functional Specifications	Description
Power Source	Two "A" cell lithium batteries
Tamper Detection	Tilt tamper
FCC Compliance	Part 15 certified
Industry Canada Compliance	RSS-210 certified
Measurement Canada Approval	Pending
Intrinsic Safety	UL Class I, Division 1, Groups C and D
Product Identification	Numeric and bar coded and serial number
Construction Materials	Gray polycarbonate housing and back plate with encapsulated electronics
Operational Specifications	Description
Operating Temperatures	-40° to 158° F (-40° to +70° C)
Operating Humidity	5 to 95% relative humidity
Frequency Band	2.405 to 2.475 GHz ISM band
Modulation	Direct Sequence Spread Spectrum
Data Integrity	Verified in every data message

Related Documents

Document Title	Document Part Number
<i>Gas Endpoint Meter Compatibility List</i>	PUB-0117-002
<i>Gas Endpoint Ordering Guide</i>	PUB-0117-001
<i>2.4GZ OpenWay Gas Module Specification Sheet</i>	Publication 100818SP-XX
<i>Endpoint Link Programming Guide</i>	TDC-0744
<i>2.4GZ OpenWay Gas Module Entity Parameters</i>	ENG-2400-500

2.4GZ OpenWay Remote Mount Gas Module Meter Compatibility List

Note This table lists meters compatible with the 2.4GZ OpenWay remote mount gas module. Due to continuous research, product improvements, and enhancements Itron reserves the right to change this list without notice.

Meter	Model	Description	Class	Comments	Endpoint Type	ERT Part Number
Elster/American/ Canadian	AC250	Aluminum case coated with two-component polyurethane. Must have top-reading odometer-style index	Residential	IPP* SEP* 2.5' cable with encoder	2.4GZ OpenWay Remote	OWG-5001-501
	AC250 Extended Top Curb meter				2.4GZ OpenWay Remote	OWG-5002-501

2.4GZ OpenWay Remote Mount Gas Module Installation

Meter	Model	Description	Class	Comments	Endpoint Type	ERT Part Number
Elster/American/ Canadian	AC425 AC425 Extended Top Curb meter	Aluminum case coated with two-component polyurethane. Must have top-reading odometer-style index	Residential	IPP* SEP* 2.5' cable with encoder	2.4GZ OpenWay Remote 2.4GZ OpenWay Remote	OWG-5001-501 OWG-5002-501
Elster/American/ Canadian	AC630 AC630 Extended Top Curb Meter	Aluminum case coated with two-component polyurethane. Must have top-reading odometer-style index	Residential	IPP* SEP* 2.5' cable with encoder	2.4GZ OpenWay Remote 2.4GZ OpenWay Remote	OWG-5001-501 OWG-5002-501
Elster/American/ Canadian	10 Metric (10B)	Iron case	Residential	IPP* SEP* 2.5' cable with encoder	2.4GZ OpenWay Remote 2.4GZ OpenWay Remote	OWG-5001-501 OWG-5002-501
Sensus/Invensys	Sonix 12,16,25,57, 600,880,2000	Pulser Metric Cubic foot	Commercial	IPP* SEP*	2.4GZ OpenWay Remote 12" lead wires 2.4GZ OpenWay Remote 12" lead wires	OWG-5001-503 OWG-5002-503
National/ Lancaster	All meters	Where direct mount is not compatible	Residential	IPP* SEP* 2.5' foot cable with encoder	2.4GZ OpenWay Remote 2.4GZ OpenWay Remote	OWG-5001-501 OWG-5002-501
Itron/Actaris/ Schlumberger/ Sprague	1A	Where direct mount is not compatible	Residential	IPP* SEP* 2.5' cable with encoder	2.4GZ OpenWay Remote 2.4GZ OpenWay Remote	OWG-5001-501 OWG-5002-501
Itron/Actaris/ Schlumberger/ Sprague	Metris 250	Straight Face meter	Residential	IPP* SEP* 2.5' cable with encoder	2.4GZ OpenWay Remote 2.4GZ OpenWay Remote	OWG-5001-501 OWG-5002-501
Schlumberger/ Sprague	400	#3 flat-face meter		IPP* SEP* 2.5' cable with encoder	2.4GZ OpenWay Remote 2.4GZ OpenWay Remote	OWG-5001-501 OWG-5002-501
Itron/Actaris/ Schlumberger/ Sprague	675, 1000	Front mount index	Commercial	IPP* SEP* 2.5' cable with encoder Also requires thicker gasket for magnet hub to clear index box. 1-hole gasket: FAB-0014-001 2-hole gasket: FAB-0014-002 4-hole gasket: FAB-0014-003	2.4GZ OpenWay Remote 2.4GZ OpenWay Remote	OWG-5001-501 OWG-5002-501
Elster/American	TC and STD CTR	American RPM series rotary meters including TC and non-TC.	Commercial	IPP* SEP* Meter must have a factory installed pulser with connector output. Purchase endpoint from Itron and correct cable interface from appropriate meter manufacturer.	2.4GZ OpenWay Remote 12" lead wires 2.4GZ OpenWay Remote 12" lead wires	OWG-5001-503 OWG-5002-503

2.4GZ OpenWay Remote Mount Gas Module Installation

Meter	Model	Description	Class	Comments	Endpoint Type	ERT Part Number
Romet	STD CTR 600 through 56000 TC 2000-23000	RM series	Commercial	IPP* SEP* Meter must have factory-installed pulser with connector output. Purchase endpoint from Itron and correct cable interface from appropriate meter manufacturer.	2.4GZ OpenWay SE1.0 Remote with 12" lead wires 2.4GZ OpenWay SE1.0 Remote with 12" lead wires	OWG-5001-503 OWG-5002-503
Romet	RM Series 600 through 56000	ECM2 Electronically compensated meter	Commercial	IPP* SEP* Meter must have connector pin with factory-installed pulse output. Purchase endpoint from Itron and correct cable interface from Romet. ECM2 must be configured for 750ms "off-time" between pulses. The ECM2 must have firmware version J or later.	2.4GZ OpenWay Remote 12" lead wires 2.4GZ OpenWay Remote 12" lead wires	OWG-5001-503 OWG-5002-503
Dresser ROOTS®	B3/LMMA	Dresser ROOTS® rotary meters equipped with WeigandWire solid state pulsers	Commercial	IPP* SEP* Meter must have factory-installed pulser with connector output. Purchase endpoint from Itron and correct cable interface from Dresser. Dresser pulser must be version 17 or higher to be compatible.	2.4GZ OpenWay Remote 12" lead wires 2.4GZ OpenWay Remote 12" lead wires	OWG-5001-503 OWG-5002-503
Dresser ROOTS®	Integral Micro Corrector IMC/W2 MC2	Electronic Volume Corrector for Series A (LMMA) and Series B ROOTS® rotary meters	Commercial	IPP* SEP* Endpoint compatible with IMC/W2 firmware version 1.91A or earlier. Pulse width must be set for 125ms. Pulse output must be at 100CF(CM) or higher.	2.4GZ OpenWay SE 1.0 Remote with 12" lead wires 2.4GZ OpenWay SE 1.0 Remote with 12" lead wires	OWG-5001-503 OWG-5002-503
Itron/Actaris	Dattus fM2/fM3		Commercial	IPP* SEP* For all meter types, pulse width must be set to .050 seconds. Meter type 11M or smaller must have pulse weight minimum of 10 cubic feet or 1 cubic meter. Meter type 16M or greater must have pulse weight minimum of 100 cubic feet or 1 cubic meter.	2.4GZ OpenWay Remote 5' cable 2.4GZ OpenWay Remote 5' cable	OWG-5001-502 OWG-5002-502

Meter	Model	Description	Class	Comments	Endpoint Type	ERT Part Number
Mercury Correctors	EC-AT Mini-P Mini-AT Mini-Max	Pressure and temperature electronic volume correctors	Commercial	IPP* SEP* Correctors must have a Form A board; Form C is NOT supported. Item #056 Pulse Scaling Factor must be set to 2.0. Item #096 Cor Vol Display must be set at 1, 2, 3, or 4 blanks. Endpoint does NOT support 8 digits (0 blanks). Item #1014 set to the preset "Itron" selection in the drop-down menu. Item #115 Output Pulse Code must be set at 1, 2, 3, or 4 (not "0").	2.4GZ OpenWay Remote 5cable 2.4GZ OpenWay Remote 5cable	OWG-5001-502 OWG-5002-502
Mercury Correctors	TCI	Temperature Compensating index	Commercial	IPP* SEP* Correctors must have a Form A board, Form C is NOT supported. Item #56 Pulse Scaling Factor must be 2.0. Item #96 must be 7, 6, 5, or 4 digits (1, 2, 3, & 4 blanks). Endpoint does NOT support 8 digits (0 blanks). Item # 1014 set to the preset "Itron" selection in the drop down menu. Compatible firmware versions on TCI are 1.06, 1.07, and 1.10.	2.4GZ OpenWay SE 1.0 Remote with 12" lead wires 2.4GZ OpenWay SE 1.0 Remote with 12" lead wires	OWG-5001-504 OWG-5002-504

*IPP: Itron Private Profile

*SEP: Smart Energy Profile

Installation Prerequisites

The following tools are required to install, program, and check the 2.4GZ OpenWay remote mount gas module. Some specific tools may be required dependent on meter or instrument type.

- Medium flat-blade screwdriver
- Small flat-blade screwdriver
- Medium Phillips-drive screwdriver
- Hand pliers
- Side-cutting pliers
- 1/4-inch nut driver or similar blunt tool
- One-inch width putty knife
- Adjustable wrench
- 3M crimping tool: E-9R, E-9BM, E-9C/CW, E-9E, or E-9Y. Itron recommends the E-9R tool.
- All-weather electrical tape
- Size T-10 Torx screwdriver
- Itron programming device to program and check 2.4GZ OpenWay remote mount gas module installation and operation:
 - FC300 with SRead with Endpoint-Link or Endpoint Link Pro version 5.5 or higher or
 - FC200 (with Bluetooth-enabled) handheld computer loaded with Endpoint-Link or Endpoint-Link Pro software to program and check endpoint.
 - ZigBee Belt-clip Radio with Endpoint-Link or EndPoint-Link Pro software - to program and check 2.4GZ OpenWay remote mount gas module installation and operation.



Caution You must program the 2.4GZ OpenWay remote mount gas module with a Bluetooth-enabled FC200 or FC300 with SRead handheld computer and ZigBee Belt Clip Radio loaded with EndPoint-Link Pro software version 5.3.1.26 or version 5.5 for Itron Private Profile (IPP) gas modules (OWG-5001-XXX).
Endpoint-Link Pro software version 5.5 must be used for Smart Energy Profile (SEP) gas modules (OWG-5002-XXX).

Mounting the 2.4GZ OpenWay Remote Mount Gas Module



This chapter provides the instructions to mount the 2.4GZ OpenWay remote mount gas module on a pipe or other flat vertical surface (wall).

Installation Options

Mount the 2.4GZ OpenWay remote mount gas module using the Pipe Mount or Wall Mount (Flat Surface) procedure.

- **Pipe Mount.** Pipe mounting is used in conjunction with the Remote Mount Kit (Itron part number CFG-0005-003). The pipe mount option places the endpoint on a pipe near the meter or instrument (not on a wall surface). This option requires a meter manufacturer's cable to connect the endpoint to the meter or instrument.
- **Flat Vertical (Wall) Mount.** Installation using the wall mount option places the endpoint on a wall or other vertical surface. A cable connects the endpoint to the meter or instrument.

Mounting Screw Specifications

Application	Itron Part Number		Description
To mount adapter plates on pipe brackets	575-9930-016		8-16 x 1/2-inch length, Type 8 slotted pan-head tapping screw - corrosion-resistant steel
To mount endpoints on adapter plates	575-9930-032		8-16 x 1-inch Type 8, slotted pan-head tapping screw, corrosion-resistant steel
To mount endpoints on sheet metal surfaces (to mount endpoints to wood surfaces, a comparable wood screw is required)	SCR-0009-001		10-16 x 1 1/2-inch Type AB thread for sheet metal, Phillips pan-head tapping screw, corrosion-resistant steel

Mounting Installation Considerations

Select a proper mounting location. Itron recommends mounting the 2.4GZ OpenWay remote mount gas module in close proximity to the meter or instrument. Some applications may require an extended cable-length. The 2.4GZ OpenWay remote mount gas module supports cable lengths up to 300 feet.

Mount the 2.4GZ OpenWay remote mount gas module in a vertical position with the endpoint label directional arrow pointed upward or downward.





Caution Vertical mounting position is important to maximize RF performance. You can mount a 2.4GZ OpenWay remote gas module with the module's label arrow pointing up or down, dependent upon the application as noted in relevant sections of this installation manual. *The module's arrow must never point to either side.* The module's tilt tamper functionality is designed to operate with the module installed vertically. The 2.4GZ module's tilt tamper will operate with the label arrow pointed up or down. The module's tilt tamper *will not operate* with the module installed horizontally (the label arrow pointed to either side).



Warning Do not mount the 2.4GZ OpenWay remote mount gas module in an orientation other than vertical (endpoint label arrow pointed upward or downward). Violating the mounting orientation requirements will void the product warranty.

Mounting the 2.4GZ OpenWay Remote Mount Gas Module on a Pipe

The following items are required to mount the 2.4GZ OpenWay remote mount gas module on a pipe or vertical flat surface (wall):

Itron Part Number	Description	
OWG-5001/5002-501 OWG-5001/5002-502 OWG-5001/5002-503 OWG-5001/5002-504	2.4GZ OpenWay remote mount gas module	 <p data-bbox="870 695 1097 726">OWG-5001-501 shown</p>
CFG-0005-003	Remote Mount Installation Kit Kit includes: <ul style="list-style-type: none"> • (2) two band clamps • (2) two tamper seals • pipe bracket • cable ties • adapter plate • Screws - (2) 1/2" - to attach the adapter plate to pipe bracket (2) 1" - to attach the endpoint to the adapter plate (3) 1 1/2" - to attach the endpoint to a vertical surface (wall)	

To mount the pipe bracket on a vertical pipe

Caution Vertical mounting position is important to maximize RF performance. You can mount a 2.4GZ OpenWay remote gas module with the module's label arrow pointing up or down, dependent upon the application as noted in relevant sections of this installation manual. *The module's arrow must never point to either side.* The module's tilt tamper functionality is designed to operate with the module installed vertically. The 2.4GZ module's tilt tamper will operate with the label arrow pointed up or down. The module's tilt tamper *will not operate* with the module installed horizontally (the label arrow pointed to either side).

1. Remove the pipe bracket and band clamp from the Remote Mount Installation Kit (Itron part number CFG-0005-003).



2. Loosen the band clamp screw until the end of the band releases.



3. Push the end of the clamp's band (1) through the holes (2) in the pipe bracket. The pipe bracket must be oriented as shown below.

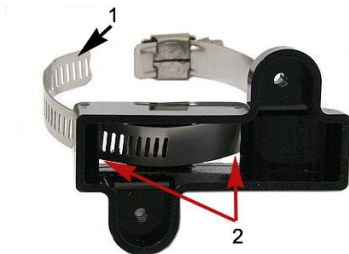

4. Place the band clamp around the pipe. The band will loosely wrap around the pipe. Push the end of the band through the band clamp screw assembly. Turn the band clamp's screw assembly to fit into the pipe bracket opening. Tighten the clamp screw until the band clamp is secure on the pipe.

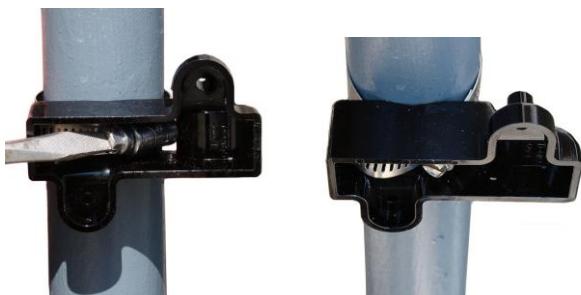

Caution The pipe bracket must fit firmly against the pipe to prevent slippage.

To mount the adapter plate on the pipe bracket

Caution Vertical mounting position is important to maximize RF performance. You can mount a 2.4GZ OpenWay remote gas module with the module's label arrow pointing up or down, dependent upon the application as noted in relevant sections of this installation manual. *The module's arrow must never point to either side.* The module's tilt tamper functionality is designed to operate with the module installed vertically. The 2.4GZ module's tilt tamper will operate with the label arrow pointed up or down. The module's tilt tamper *will not operate* with the module installed horizontally (the label arrow pointed to either side).

1. Place the adapter plate on the pipe bracket with the mounting lug at the top or bottom. The adapter plate screw bosses fit into the pipe bracket recess.

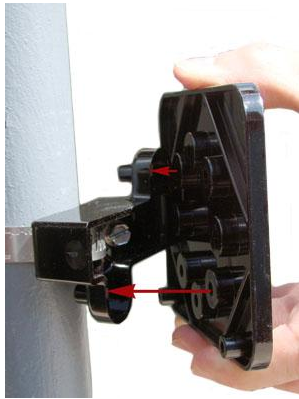

2. Ensure the adapter plate is positioned as shown below with the mounting lug (1) at the top or bottom. To install the adapter plate on a vertical pipe, use the two shortest (1/2-inch) adapter plate mounting screws from the Remote Mount Installation Kit. Place the mounting screws (2) in the holes shown below.

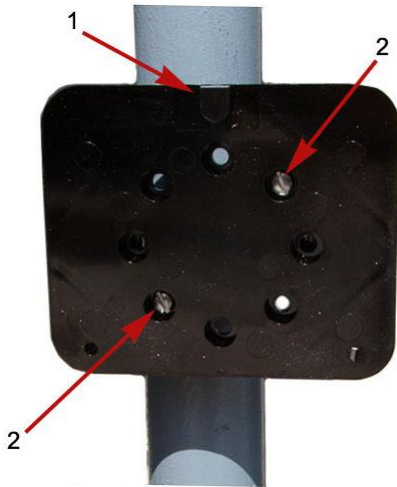

Upright module mounting

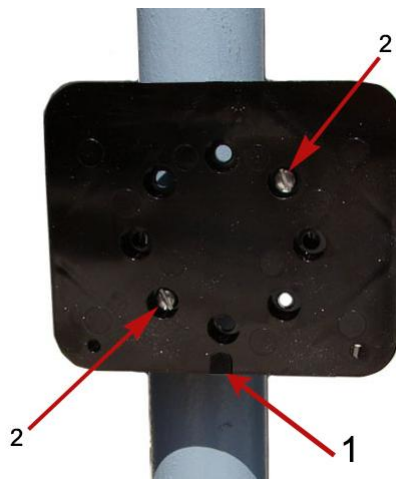

Inverted module mounting (curb meter)

3. Tighten both screws securely in an alternating fashion. Itron recommends 9 to 12-inch-pounds torque.

To mount the 2.4GZ OpenWay remote mount gas module on the adapter plate

1. Take the 2.4GZ OpenWay remote mount gas module and the two 1-inch mounting screws from the Remote Mount Installation kit. Place the back of the remote endpoint against the face of the adapter plate. The adapter plate mounting lug (1) must be positioned just above the endpoint mounting lug recess (2).

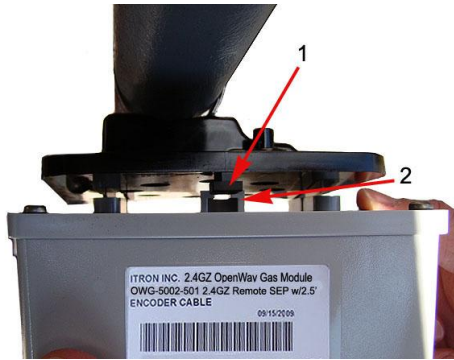

2. Push up on the 2.4GZ OpenWay remote mount gas module until the adapter plate mounting lug (1) is as far as possible inside the endpoint mounting lug recess (2).



3. Install the two 1" endpoint-mounting screws from the installation kit.



4. Tighten the endpoint mounting screws evenly in an alternating fashion. Itron recommends 9 to 12 inch-pounds torque.

Adapter Plate Mounting Positions

The following pictures show adapter plates mounted on horizontal or 45-degree angle pipes.

 **Caution** Regardless of the pipe's direction, the adapter plate mounting lug must always be at the top or bottom. (Bottom lug installation for inverted curb meter module mounting).

If the pipe is a 45-degree angle up to the right, install the adapter plate as shown below.

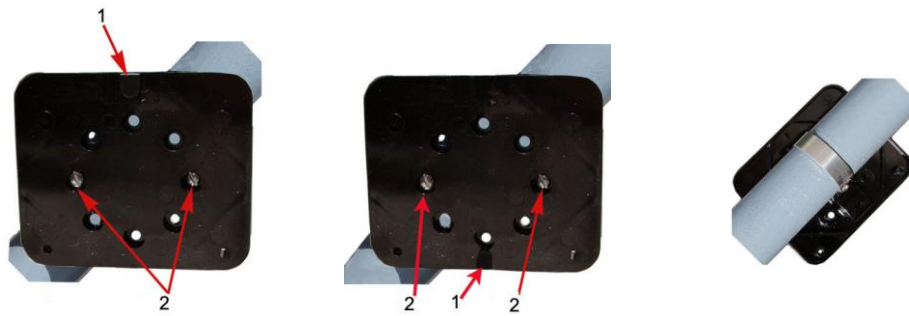

Typical module mounting **Inverted module mounting (curb meter)** **Mounted adapter plate back view**

If the pipe is a 45-degree angle up to the left, install the adapter plate as shown below.

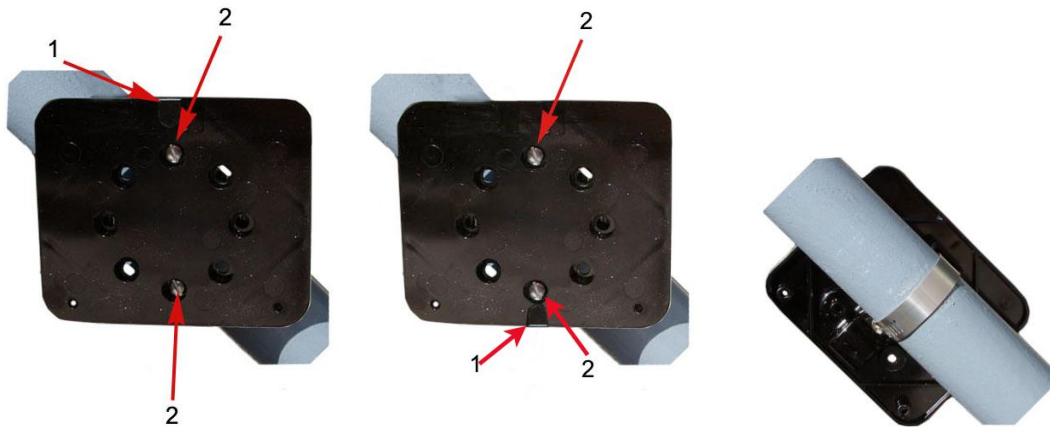

Typical module mounting **Inverted module mounting (curb meter)** **Mounted adapter plate back view**

If the pipe is horizontal, install the adapter plate as shown below.

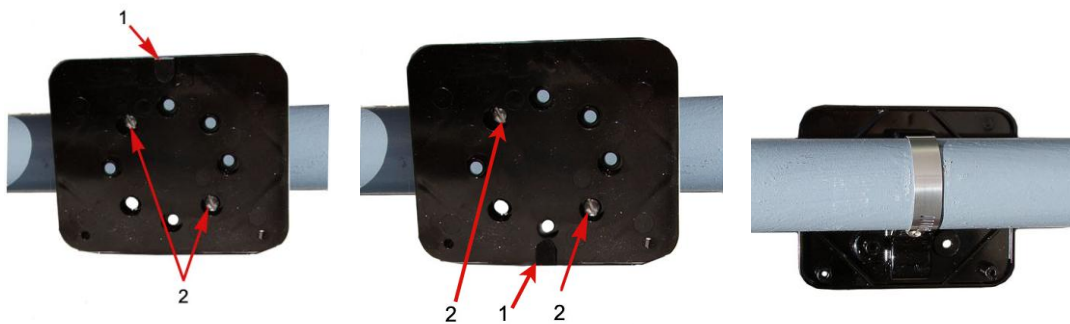

Typical module mounting **Inverted module mounting (curb meter)** **Mounted adapter plate back view**

To install tamper seals and cable ties

1. Ensure the label arrow points up or down (1). Place the new tamper seals from the Remote Mount Installation Kit over the 2.4GZ OpenWay remote mount gas module mounting screws (2, 3). Firmly push both tamper seals all the way into place with a 1/4-inch nut driver or similar blunt tool.

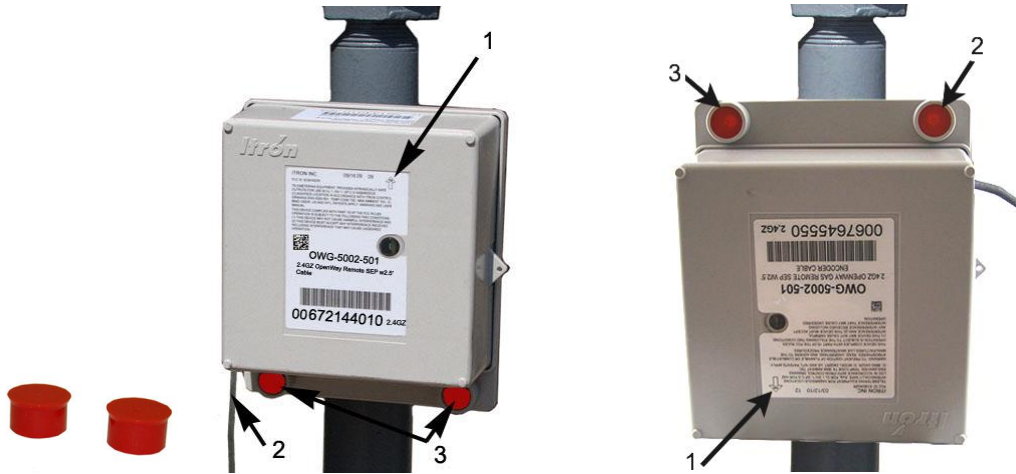

Note A tamper seal is fully seated when the top of the tamper seal is approximately 1/16-inch below the top of the screw recess.

2. Gather any excess endpoint cable. Loop a cable tie around the pipe and excess endpoint cable.



3. Insert the chiseled end of the cable tie into the locking end and pull the cable tie tight. Cut off and properly dispose the excess cable tie.



2.4GZ OpenWay remote mount gas module pipe mount installation is complete.

Mounting the Endpoint on a Wall or Other Flat Vertical Surface



Caution Vertical mounting position is important to maximize RF performance. You can mount a 2.4GZ OpenWay remote gas module with the module's label arrow pointing up or down, dependent upon the application as noted in the relevant section of this installation manual. *The module's arrow must never point to either side.* The module's tilt tamper functionality is designed to operate with the module installed vertically. The 2.4GZ module's tilt tamper will operate with the label arrow pointed up or down. The module's tilt tamper *will not operate* with the module installed horizontally (the label arrow pointed to either side).

To mount the 2.4GZ OpenWay remote mount gas module on a wall or other flat vertical surface

Note For easier installation, you may drill three pilot holes in the mounting surface (use the proper size drill bit to accommodate the endpoint mounting screws, see the Drilling Template below). When drilling pilot holes to mount the 2.4GZ OpenWay remote mount gas module, the holes for the two bottom screws must be on a horizontal line. If the endpoint will be mounted on a sheet metal surface, use the mounting screws included with the 2.4GZ OpenWay remote mount gas module mounting kit. Use a comparable wood screw to mount the endpoint on a vertical wood surface.

Carefully select a mounting location free from electrical wires. The mounting location must have the proper clearance to accommodate the 1-1/2-inch endpoint mounting screws so nothing is damaged by the drill or mounting screws.

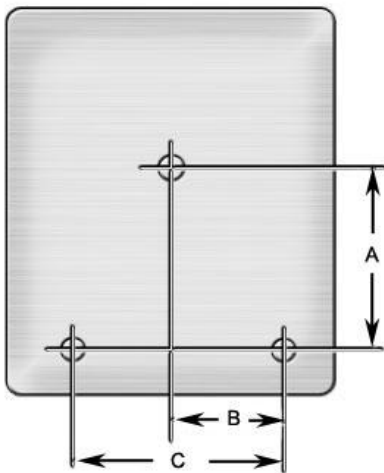

2.4GZ OpenWay remote mount gas module drilling template

- A 3 inches
- B 1-11/16 inches
- C 3-3/8 inches

1. Using the three 1-1/2-inch mounting screws from the Remote Mount Installation Kit, turn the mounting screw for the mounting lug (top of endpoint) part way into the mounting surface.



2. Place the 2.4GZ OpenWay remote mount gas module mounting lug recess (on the top of the endpoint backplate) just under the screw head. Slide the endpoint upward until the screw head fits completely inside the mounting lug recess. Several adjustments may be necessary to properly position the screw for endpoint mounting.



3. Install the bottom two mounting screws. Fasten screws in an alternating fashion until fully tightened to secure the endpoint firmly in position.



To install tamper seals and cable ties

1. Place a new tamper seal (from the Remote Mount Installation Kit) over each endpoint mounting screw.



2. Firmly push both tamper seals into place with a 1/4-inch nut driver or similar blunt tool.

Note A tamper seal is fully seated when the top of the tamper seal is approximately 1/16 inch below the top of the screw recess.

3. To reduce the risk of cable damage, secure the excess endpoint cable with the cable ties from the Remote Mount Installation Kit. Pull the cable tight. Remove and properly dispose the excess cable tie.



2.4GZ OpenWay remote mount gas module installation on a vertical flat surface or wall is complete.

CHAPTER 3

Rotary Meter Installation

This chapter provides the instructions to install the 2.4GZ OpenWay remote mount gas module on rotary gas meters. Reference the Gas Endpoint Meter Compatibility List (see [Related Documents](#) on page 3) for rotary meters compatible with the 2.4GZ OpenWay remote mount gas module.



American rotary meter



Dresser ROOTS® Series LMMA rotary meter



Dresser ROOTS® series B3 meter



Dresser ROOTS® IMCW2 meter



Romet Imperial series RM meter



Romet Imperial ECM2 meter

Required Installation Materials Available from Itron

The materials in the following table are required to install a 2.4GZ OpenWay remote mount gas module.

Itron Part Number

OWG-5001-503

OWG-5002-503

Note: this remote mount endpoint comes standard with 12" lead wires and may be shipped directly to the meter manufacturer for a factory-installed cable (interface).



Important The interface cable must be purchased directly from the meter manufacturer.

CFG-0005-003

Remote Endpoint Mounting Kit



Connecting the 2.4GZ OpenWay Remote Mount Gas Module to the Rotary Meter Cable

You may ship the Itron 2.4GZ OpenWay remote mount gas module directly to the meter manufacturer for a factory-installed cable. If you connect the endpoint to the meter using an existing cable purchased from the meter manufacturer, complete the following cable installation procedure.



Caution The purchased cable must have a mating connector compatible to the meter receptacle. Dresser ROOTS® cables may be wired in different configurations for specific applications. If necessary, contact Dresser ROOTS® Meters for wiring diagrams for your specific application.

To connect the 2.4GZ OpenWay remote mount gas module to the rotary meter cable

1. Remove the backplate (4 screws) from the 2.4GZ OpenWay Remote and expose the module's lead wires. The backplate and screws will be re-installed on the gas module later in this procedure so store them (temporarily) in a safe, secure place.

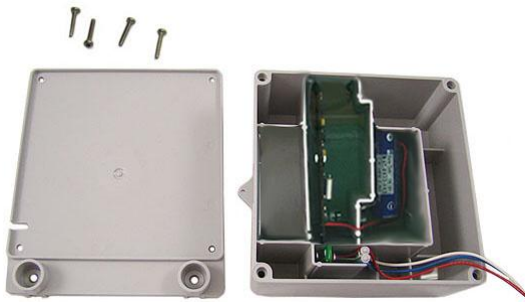

2. Insert the lead wires from the 2.4GZ OpenWay remote mount gas module into new 3M gel connectors (Itron part number CON-0023-001) together with the same colored lead wire from the meter cable (see the wiring table below) and crimp using a 3M hand-held crimping tool.



Note Do not strip lead wire prior to inserting the wire in the gel connector.

Rotary Meter to Remote Module Wire Table

Rotary Meter Wire	Remote module wire
Red	Red
White	White
Blue	Blue

3. After completing the wiring connections, install a cable tie to the meter cable just below the exposed colored lead wires on the cable insulation. Remove the excess cable tie using a hand-held sidecutter pliers. The cable tie performs as a cable strain relief to mitigate the risk of destructive tension on the lead wires.

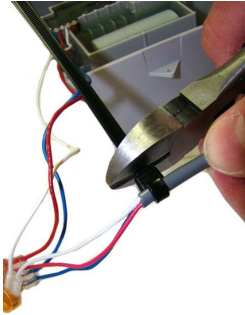

4. Tuck the three gel connectors and cable tie inside the module housing. Position the cable tie as shown in the placement schematic below.

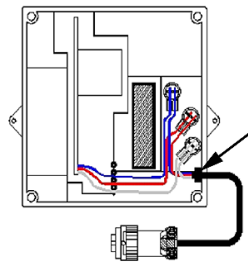
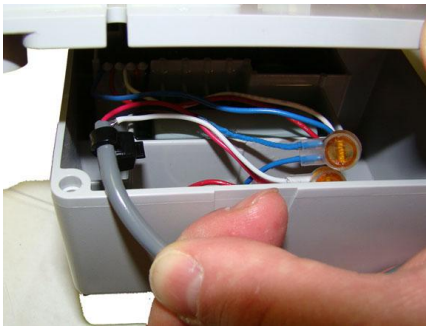

5. Install the 2.4GZ OpenWay remote mount gas module backplate using the four screws previously removed from the module and a Torx T-15 screwdriver. Install the new 2.4GZ OpenWay remote mount gas module on the wall or a pipe using the Remote Endpoint Mount Kit (Itron part number CFG-0005-003). See [Mounting the 2.4GZ OpenWay Remote Mount Gas Module](#) on page 8 for mounting instructions.



To connect the 2.4GZ OpenWay remote mount gas module cable assembly to the rotary meter

Caution Verify the cable connector mates with the meter connector. Meter manufacturers use different connector styles (types).

1. Align the large lug on the 2.4GZ OpenWay remote mount gas module connector with the large notch on the meter connector.

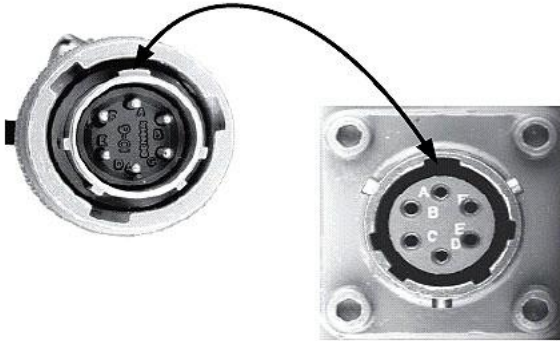

2. Align the lock ring notches on the module cable connector with the pins on the meter connector.

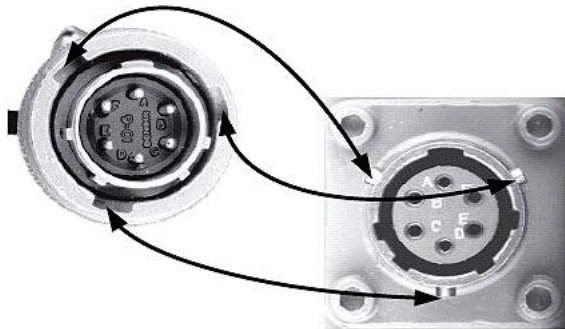

3. Hold the lock ring on the module connector back and push the plug into the meter connector until it is securely seated.
4. Turn the lock ring clockwise as far as it will go. You will feel it snap into place when it locks.

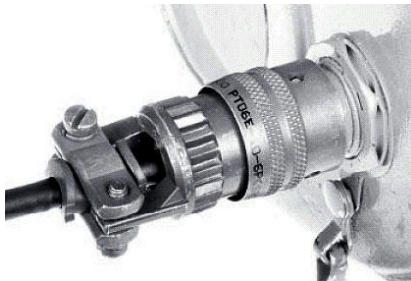

Warning To remove the module connector plug from the meter connector jack, push in on the lock ring, turn the lock ring counterclockwise as far as possible, and pull out the plug body. Do not pull on the module's connector cable.

Programming 2.4GZ OpenWay Remote Mount Gas Modules for Dresser ROOTS® Rotary Meters

To program 2.4GZ OpenWay remote mount gas modules for use with Dresser ROOTS® rotary meters, use the meter drive rates from the drive rate table in this section.

B3, LMMA & S3A CTR/TC Meter Pulse Rates for Remote Module Programming



Caution Do not use these meter drive rates to program residential direct-drive or commercial direct-drive modules. Use the information in the following tables to program 2.4GZ OpenWay remote mount gas modules connected to Dresser ROOTS® rotary meters.

B3 CTR Meter Size	B3 CTR Meter Pulse Rate	LMMA CTR Meter Size	LMMA CTR Meter Pulse Rate
8C	10	1.5M	10
11C	10	3M	10
15C	10	5M	10
2M	10	7M	10
3M	10	11M	10
5M	10	16M	100
7M	10	23M	100
11M	10	38M	100
16M	100	56M	100
23M	100	102M	100
38M	100		
56M	100		
LMMA CTR Meter Size	LMMA CTR Meter Pulse Rate	LMMA TC Meter Size	LMMA TC Meter Pulse Rate
1.5M	10	1.5M	10
3M	10	3M	10
5M	10	5M	10
7M	10	7M	10
11M	10	11M	10
16M	100	16M	100
23M	100		
38M	100		
56M	100		
102M	100		

Meters built 1/99 and beyond		Meters built prior to 1/99	
B3 TC Meter Size	B3 TC Meter Pulse Rate	B3 TC Meter Size	B3 TC Meter Pulse Rate
8C	10	8C	50
11C	10	11C	50
15C	10	15C	50
2M	10	2M	50
3M	10	3M	50
5M	10	5M	50
7M	10	7M	50
11M	10	11M	50
16M	100	16M	500
S3A CTR Meter Size	S3A CTR Meter Pulse Rate	S3A TC Meter Size	S3A TC Meter Pulse Rate
1.5M	10	1.5M	10
3M	10	3M	10
5M	10	5M	10
7M	10	7M	10
11M	10	11M	10
16M	100	16M	100

Installing the 2.4GZ OpenWay remote mount gas module to the Elster American Meter RPM Series Rotary Meter

Some meter manufacturers provide endpoint mounting kits and installation procedures for their meters. If 2.4GZ OpenWay remote mount gas module to Elster American RPM meter installation instructions are not available, follow the installation procedure in this section.



Elster American Meter RPM Series Rotary Meter

To install the 2.4GZ OpenWay remote mount gas module on an Elster American RPM series meter

1. Remove the meter's top plate by removing the two (2) 5mm screws and carefully prying up on the plate. The plate is secured with an o-ring seal. Remove the o-ring from the plate.

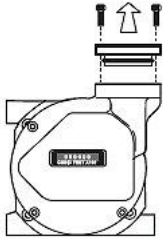

Caution If the o-ring is damaged during removal, obtain a replacement from Elster American Meter Co.

2. Look into the meter tower and find the meter switch lead and connector (4-pin).

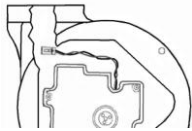

3. If the lead and connector are not visible or cannot be found, remove the four (4) 5mm mounting screws and the register cover. The meter switch lead and connector will be visible inside the cover.

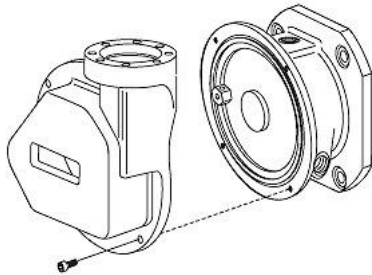

Note Save any meter tags. You will re-install them later in the installation process.

4. Feed the lead and connector into the register cover tower.

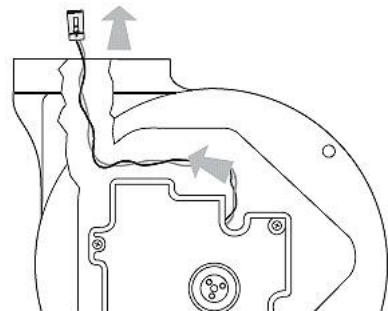

5. If you removed the register cover, replace the cover using the four (4) 5mm mounting screws.

6. Attach the 4-pin male connector on the Elster American Meter adapter plate to the 4-pin female connector inside the meter's tower. The connectors will slide together and latch.

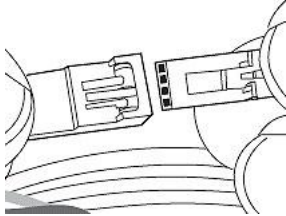

7. Carefully push the connectors and wires into the meter tower housing.

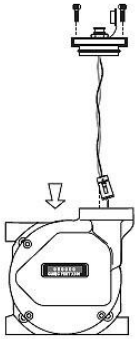

8. Lubricate the o-ring with o-ring lubricant and install the o-ring on the adapter plate. Insert the adapter plate into the tower and tighten the (2) 5 mm screws.

To connect the manufacturer cable to the endpoint

Note Connection to an Elster American Meter requires a cable interface compatible to an Elster American Meter RPM rotary meter.

1. Trim the 2.4GZ OpenWay remote mount gas module wires to 3.5-inches.

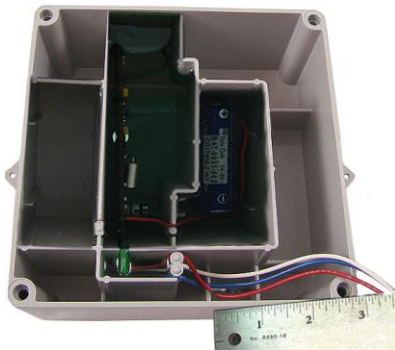

2. Carefully strip the insulation covering from the meter cable (purchased from the meter manufacturer) approximately 1-1/2-inches from the end.

Caution Do not cut through the individual wire insulation.

3. Separate the black, white, and blue wires for connection to the 2.4GZ OpenWay remote mount gas module. Cut off the unused wires even with the outer covering (insulation).

Caution Do not strip the individual wires.

4. Connect the meter cable to the 2.4GZ OpenWay remote mount gas module using 3M gel-cap connectors. Follow the wire connection table and wiring diagrams below. See [Installation Prerequisites](#) on page 7 for appropriate 3M crimping tools.

Important Use a crimping tool compatible with gel-connectors. Do not use a standard pliers for crimping gel-connects. The crimping tool provides an even pressured crimp to make a secure connection. Apply pressure for three seconds until the gel cap is fully crimped (collapsed) to allow time for the low viscosity silicone-based gel to flow. If the silicone gel flows out of the crimped connector, avoid touching the gel. Gel flowing from the connector provides environmental protection for the connection.

American RPM Meter to 2.4GZ Remote Mount Module Wire Connections

American RPM Meter wire	2.4GZ remote mount module wire
Red	Red
White	White
Black	Blue

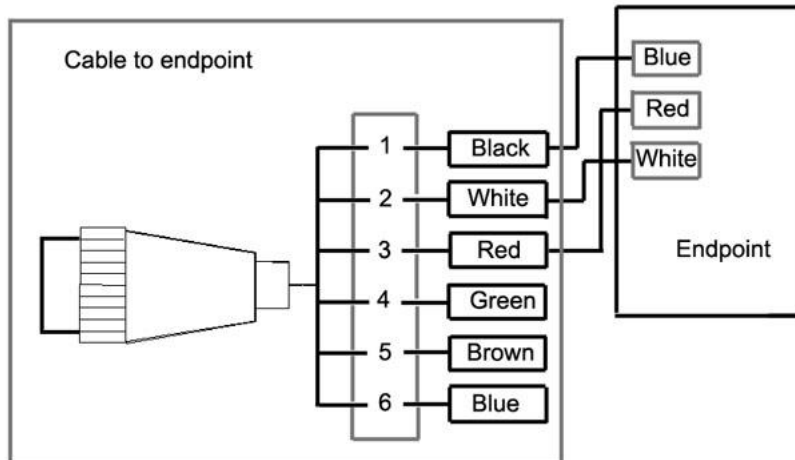

5. Insert the meter cable through the slot on the module backplate. Install a cable tie to the meter cable wire below the meter cable insulation to provide strain relief. Position the cable tie as shown in the position schematic below.

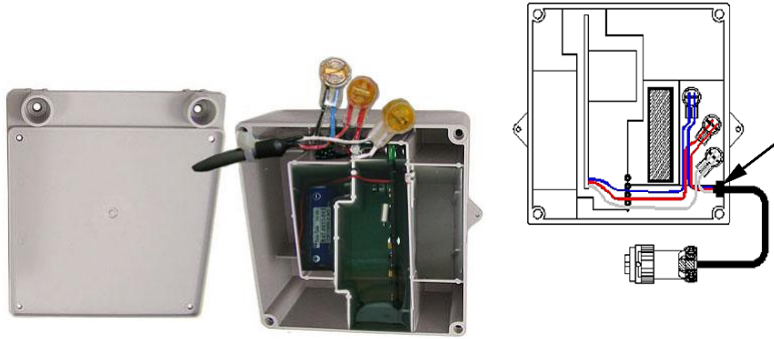

6. Tuck the connectors and cable tie into the endpoint housing. Place backplate on the assembly and tighten the four backplate screws using a size T-10 Torx screwdriver.

Important Verify the cable tie and gel connectors are inside the endpoint housing and the cable extends out of the slot in the backplate. Torque the backplate mounting screws to 9 - 12 inch-pounds.



To install the 2.4GZ OpenWay remote mount gas module cable

1. Insert the plug on the cable connected to the module into the receptacle on the meter adapter plate.

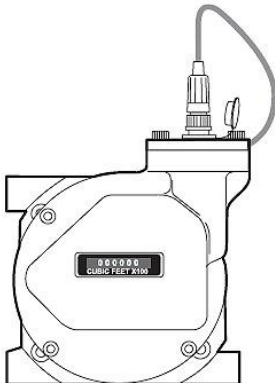

2. Tighten the threaded collar on the plug onto the American Meter interface receptacle. Verify the connection is hand-tight.

Mounting the 2.4GZ OpenWay Remote Mount Module

Select an appropriate mounting location on adjacent piping close to the meter. Using the pipe bracket, mounting plate and band clamps from the Remote Mount Kit (Itron part number CFG-0005-003), secure the 2.4GZ OpenWay remote mount gas module. Use the cable ties from the kit to secure any excess wire to the piping (see [Mounting the 2.4GZ Remote Mount Module on a Pipe](#) on page 9).



Installing the 2.4GZ OpenWay Remote Mount Gas module to the Romet Electronically Compensated Meter (ECM2®)



The Romet ECM2® meter has three Form "A" outputs that can be configured at the factory to provide any combination of the following three outputs:

- Uncorrected volume (UNC VOL)
- Corrected volume (COR VOL)
- Alarm

The pulse weight for the volumetric outputs is configured in *SetUp Mode* at **Menu items>SET UNC OUT** and **SET COR OUT**. Since Setup Mode is fully configurable, the ECM2® module is universally adaptable to all Romet TC meter bodies. Reference the Romet technical manual for specific details on the ECM2®.

Connecting the 2.4GZ OpenWay Remote Mount Gas Module to the Romet ECM2[®] Meter

Connect the correct interface wirings and set the output pulse spacing to complete 2.4GZ OpenWay remote mount gas module installation with the Romet ECM2[®] meter. See the ECM2[®] Interface Wiring Table below to complete wire connections.

Function	(+)UC	(-)UC	(+)CC	(-)CC	(+)ALM	(-)ALM	(+)Aux.CC	(-)Aux.CC
Endpoint Wire	White and Blue	Red	White and Blue	Red	White and Blue	Red	White and Blue	Red
Pin location for Cannon Connector Part Number	34-125-20	C	B	A	B	E	D	
	34-125-40	A	B	C	D	E	F	
	34-125-41	A	B	C	D	E	F	
	34-125-42	E	F	A	B	C	D	
	34-125-43			A	B	E	F	C D
	34-125-44							A B
	34-125-45	A	B	E	D	C	F	
	34-125-50	3	1	2	5	6	4	
	34-125-51	3	1	2	5			6 4



Caution Set the ECM2[®] output pulse spacing to 750ms for operation with the 2.4GZ OpenWay remote mount gas module. Output spacing represents an *off-time* between pulses.

Romet ECM2 Mounting Requirement

This mounting procedure requires the Romet ECM2/ERT Mounting Kit (Romet part number 34-444-1-KIT).



To mount the 2.4GZ OpenWay remote mount gas module on the Romet ECM2 meter

1. Remove the module screw from the back of the ECM2 meter and discard.

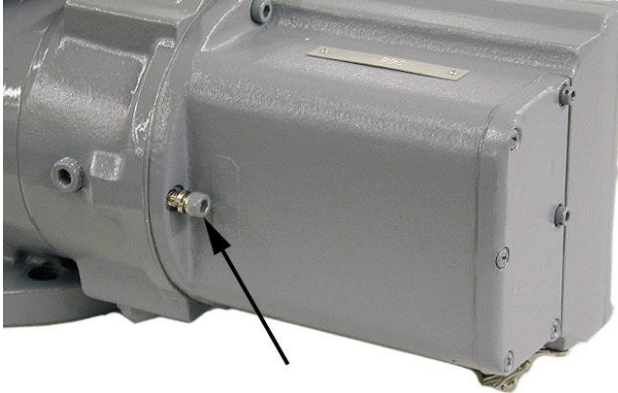

2. Insert the mounting screw fitted with the three lock washers. Two lock washers are used as spacers as shown.



3. Attach the mounting plate to the meter. Insert the mounting screw where the module screw was removed. Torque the mounting screw to 5 - 7 ft.lbs. to secure the plate to the Romet meter.



4. Mount the 2.4GZ OpenWay remote mount gas module using the pre-drilled holes on the mounting plate and the module mounting screws. Place new tamper seals over the two screws. Press tamper seals into place using an 1 1/32" nut driver or similar blunt tool. Connect the module to the meter using the previously installed cable interface.



Programming the 2.4GZ OpenWay Remote Mount Gas Module Assembly

 **Caution** The 2.4GZ Remote Mount Gas Module must be programmed before use.

Program the 2.4GZ OpenWay remote mount gas module with a Bluetooth-enabled FC200 or FC300 with SRead handheld computer and ZigBee Belt Clip Radio loaded with Endpoint-Link or Endpoint-Link Pro software version 5.3.1.26 or version 5.5 for Itron Private Profile (IPP) gas modules (OWG-5001-XXX). Endpoint-Link Pro software version 5.5 must be used for Smart Energy Profile (SEP) gas modules (OWG-5002-XXX). See the Endpoint-Link Endpoint Programming Guide (TDC-0744) for more complete programming information. An Itron magnet is also required for programming.



FC200SR FC300 with SRead Zigbee Belt Clip Radio Itron Magnet

To program the 2.4GZ OpenWay remote mount gas module

1. Program the meter drive rate into the 2.4GZ OpenWay remote mount gas module using the handheld computer and Belt Clip Radio. Programming parameters are based on the configuration file loaded into the handheld computer.
2. Place the magnet over the barcode on the module cover label with the magnet face (inked Itron logo and part number) arrow pointed up toward the top of the module.



3. Hold the magnet in place for 5 seconds and remove it.
4. The LED will blink red three times. This signifies the 2.4GZ OpenWay remote mount gas module is searching for a programming device. Within a few seconds of locating the handheld computer, the red LED will blink five more times. The handheld computer will confirm programming success or failure.



5. **Read** the 2.4GZ OpenWay remote mount gas module using the handheld computer and Belt Clip Radio.
 - If the read result is higher than the number programmed in Step 1, the 2.4GZ OpenWay remote mount gas module is counting correctly.
 - If the read result is not higher than the number programmed in Step 1, replace the 2.4GZ OpenWay remote mount gas module.

CHAPTER 4

Electronic Instrument Installation

This section provides the instructions to install the 2.4GZ OpenWay remote mount gas module on the Mercury Instruments Mini-P, Mini-AT, Mini-Max, and EC-AT and Dresser ROOTS® Micro Correctors.



Mini-AT



Mini-Max



EC-AT



TCI



IMC/W2



MC2

Installation Prerequisites

2.4GZ OpenWay remote mount gas module installation to a Mercury Instrument requires:

- 2.4GZ OpenWay remote mount gas module compatible to a Mercury Instrument (see the [2.4GZ OpenWay Remote Mount Gas Module Meter Compatibility List](#) on page 3).
- Mercury Instrument compatible with the remote endpoint.
- Proper tools and devices for installation and programming (see [Installation Prerequisites](#) on page 7).



Installation Overview

Installing the 2.4GZ OpenWay remote mount gas module to a Mercury Instrument involves five tasks:

1. [Programming the Mercury Instrument](#) on page 37 (reference the Mercury Instrument Programming Guide for more information).
2. Installing Mercury retrofit parts (if necessary).
3. Attaching the 2.4GZ OpenWay remote mount gas module to a pipe or vertical flat surface (wall) (see [Mounting the 2.4GZ OpenWay Remote Mount Gas Module](#) on page 8).
4. Wiring the 2.4GZ OpenWay remote mount gas module to the Mercury Instrument (see [Wiring the 2.4GZ OpenWay Remote Mount Gas Module to the Mercury Instrument](#) on page 39).
5. Programming the 2.4GZ OpenWay remote mount gas module (see [Programming the 2.4GZ OpenWay Remote Mount Gas Module](#)).

Programming the Mercury Instrument

Code Settings

Volume Corrector Type	Item Code Settings and Corresponding Terminal Board Channel											Terminal Board Connections*
	Pulse Output Options	Channel A		Channel B		Channel C		Number of Blanked digits on CorVol Display	Pulse Output Spacing			Ka, Ya = Channel A
		#056	#93	#057	#094	#058	#095		#96	#115	#1014	
ECAT	Pulse Board Ver-1(3) Form-C	n/a	n/a	n/a	n/a	n/a	n/a	n/a	n/a	n/a	n/a	Module does not support a Form-C pulse output board.
	Pulse Board Ver-2(3) Form-A	2.0000	0	2.0000	0	2.0000	0	1, 2, 3, or 4	1, 2, 3, or 4	n/a	n/a	Ka, Kb, Kc (Red Wire) Ya, Yb, Yc (Blue & White Wire) Connection must be on same terminal board channel (for example, Ka/Ya; Kb/Yb; Kc/Yc).
	Pulse Board Ver-3(2) Form-C1 Form-A	n/a	n/a	n/a	n/a	2.0000	0	1, 2, 3, or 4	1, 2, 3, or 4	n/a	n/a	Kc (Red Wire) Y (Blue & White Wire). For this option, module must be connected to Channel C.
Mini with Form A Mainboard	Main Board Type-2	2.0000	0	n/a	n/a	n/a	n/a	1, 2, 3, or 4	1, 2, 3, or 4	n/a	n/a	K (Red Wire) Y (Blue & White Wire). For optional SPA Bd., jumper must be installed on J1-B as indicated in the Mercury Quick Reference Guide (page 148) for Form A.
Mini-AT	JB29, JB30 & JB31 Jumpered for Form-A	2.0000	0	2.0000	0	n/a	n/a	1, 2, 3, or 4	1, 2, 3, or 4	n/a	n/a	K (Red Wire) Y (Blue & White Wire). For optional SPA Bd., jumper must be installed on J1-B as indicated in the Mercury Quick Reference Guide (page 148) for Form-A.
	JB29, JB30 & JB31 Jumpered for Form-C	n/a	n/a	n/a	n/a	n/a	n/a	n/a	n/a	n/a	n/a	Module does not support a Form-C pulse output board.
Mini-Max	All Main Boards	2	0	2	0	n/a	n/a	1, 2, 3, or 4	1, 2, or 4	n/a	n/a	K (Red Wire) Ya or Yb (Blue & White Wire)
	Form C Main Board	n/a	n/a	n/a	n/a	n/a	n/a	n/a	n/a	n/a	n/a	Module does not support a Form-C pulse output board.
	Form A Main Board	2.0000	0	2.0000	0	n/a	n/a	1, 2, 3, or 4 blanks (7, 6, 5, or 4 active)	n/a	Iron selection in dropdown menu.	Iron selection in dropdown menu	Connections to channels of output pulses are made through loose unterminated cable wires and gel connect connectors.

Notes:

- Code 0 for items 093, 094 & 095 = Corrected Volume Pulse Data
- Code 1 for item 115 = 1.000 Sec.
- Code 2 for item 115 = 2.000 Sec.
- Code 1 for item 096 = blank 1 digit and display 7 digits
- Code 2 for item 096 = blank 2 digits and display 6 digits
- Code 3 for item 096 = blank 3 digits and display 5 digits
- Code 4 for item 096 = blank 4 digits and display 4 digits

*For more information, see pages 11-20 of the "Basic Pulse Information for Mercury Instruments, Inc., Electronic Volume Correctors" manual, or contact Mercury Instruments at 513-272-1111.

Mercury corrector programming parameters:



Caution A Mercury Instrument Volume Correctors must have a Form A board. A Form C board is not compatible with the 2.4GZ OpenWay remote mount gas module.

For TCI, when using both outputs, items 1014 and 1015 must be set to *Itron*.

- Item #056: Pulse A Scaling. Set at 2.0000 for a form A switch.
- Item #057: Pulse A Scaling. Set at 2.0000 for a form A switch.
- Item #058: Pulse A Scaling. Set at 2.0000 for a form A switch.
- Item #090: Corrected Volume Units: Code (0-20) selects the unit of measure for Corrected Volume (Item000) and other "CorrVol" related items.
- Item #092: Uncorrected Volume Units: Code (0-20) selects the unit of measure for Uncorrected Volume (Item002) and other "UncVol" related items.
- Item # 093, 094, 095: Type of gas volume information to be sent. For "CorrVol" selected, must be set at 0.
- Item # 096: Corrected Volume Display: Must be set at 1, 2, 3 or 4 blanks. Endpoint does not support a setting of 0 blanks.
- Item # 097: Uncorrected Volume Display: Must be set at 1, 2, 3, or 4 blanks. Endpoint does not support a setting of blanks.
- Item # 098: Check drive rate of the corrector. Should be the same as the plate above the uncorrected dials and the same as the plate on the index drive of the meter.
- Item # 115: Output Pulse Code: Must be set at 1 or 2.

Wiring the 2.4GZ OpenWay Remote Mount Gas Module to the Mercury Instrument

Use the Terminal strip connector (Phoenix connector) in the Mercury Instrument to connect the 2.4GZ OpenWay remote mount gas module to the instrument.

Note In Mercury Instrument EC-AT correctors, the connector may be soldered to the pulse board.

The 2.4GZ OpenWay remote mount gas module has three lead wires (red, white, and blue). The red wire is attached according to Mercury Instrument Code Settings (see [Code Settings](#) on page 38).

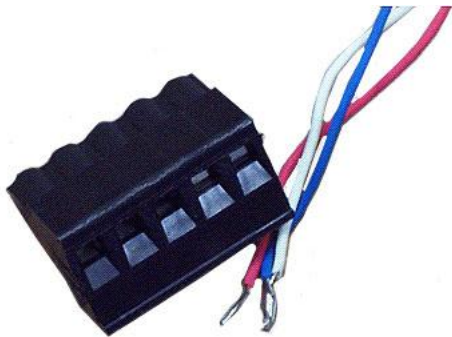

The blue and white wires are twisted together and attached according to Mercury Instrument's Code Settings (see [Code Settings](#) on page 38).

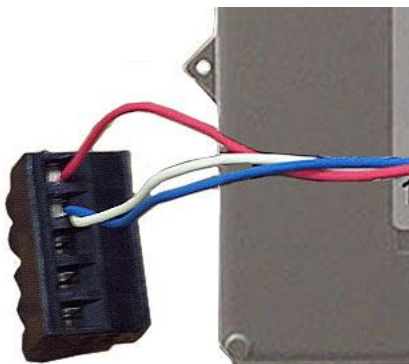

To wire the 2.4GZ OpenWay remote mount gas module to the Mercury Instrument

1. Insert the module cable into the instrument's compression connector.



2. Strip one inch of the outer insulation from the 2.4GZ OpenWay remote mount gas module. Strip 1/4-inch individual wire insulation from the red, white, and blue lead wires.

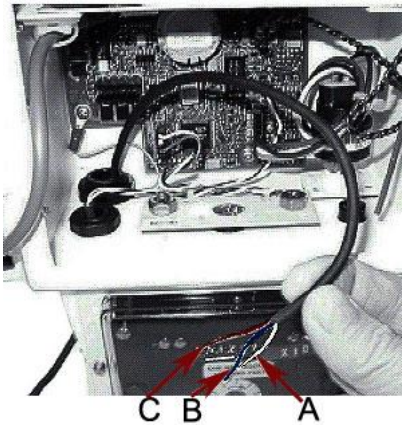

- A White wire
- B Blue wire
- C Red wire



Caution Keep wires away from the rotating magnetic spindle in the Mercury Instrument.

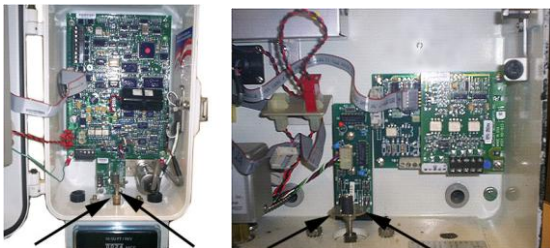

3. See [Mounting the 2.4GZ OpenWay Remote Mount Gas Module](#) on page 8 for module mounting instructions.

Wiring Dual Modules to a Mercury Instrument

This section includes the information to wire dual endpoints to a single Mercury Instrument. Installation requires the correct programming parameters (see [Code Settings](#) on page 38).

With Itron 2.4GZ OpenWay remote mount gas modules, utilities can receive *corrected* and *uncorrected* consumption values by installing two modules. The module for *corrected* reads is attached to the instrument's pulse output. The module for *uncorrected* reads is attached to the input switch board. The *corrected* pulse output is programmable; the *uncorrected* pulse output is dependent on the connected meter's drive rate.



Important Some Mercury Instruments have two pulse outputs so the *uncorrected* pulse output could be connected to the additional output, but the connection should be to the input switch board in case the instrument battery fails. Counts will be collected if the *uncorrected* pulse is connected to the switch board since the board is not dependent on battery power.



Dual remote modules mounted on a Mercury Instrument

To install dual 2.4GZ OpenWay remote mount gas modules to a Mercury Instrument Mini-Max Case Corrector using Mercury Kit 22-1077

Required Tools

- Drill with 3/16-inch bit
- Screw drivers: slotted and Phillips head (medium size)
- 1-inch open-end wrench or medium-size adjustable wrench
- 7/16-inch open- or closed-end wrench
- Clean shop rag
- Alcohol wipe

1. Place the Mercury Instrument in *shutdown* condition and disconnect all power from the Mini-Max main board.
2. Remove the battery pack from the corrector and set aside.
3. Remove the four screws from the main board and the board from the enclosure. Set the board aside.
4. Remove the two hex screws from the input switchboard and the switchboard from the enclosure and set aside.

Warning The battery pack, main board and switchboard may be damaged if left in the Mercury Instrument while completing this installation.

5. Drill two 3/16-inch holes in the back of the Mini-Max enclosure as specified by the information included in the kit. Remove any metal shavings from the enclosure.
6. Clean the 2.4GZ OpenWay remote mount gas modules with the alcohol wipe where you will place the Corrected and Uncorrected labels (included in the kit).

Note Clean the 2.4GZ OpenWay remote mount gas modules with the alcohol wipe to ensure good label adhesion.

7. Mount the module for *corrected* pulse outputs on the left bracket mounting space. Insert three #8-32 x 1/2-inch screws in a triangular pattern. Install the top screw so the head of the screw is approximately 1/8-inch from the module mounting bracket surface. Slide the module onto the screw so the mounting lug fits securely onto the screw. If necessary, remove the module and make any necessary adjustment to the screw depth to ensure a secure fit. Install the two bottom screws in an alternating fashion.
8. Mount the module for *uncorrected* pulse outputs on the right bracket mounting space. Insert three #8-32 x 1/2-inch screws in a triangular pattern. Install the top screw so the head of the screw is approximately 1/8-inch from the Module Mounting Bracket surface. Slide the module onto the screw so the mounting lug fits securely onto the screw. If necessary, remove the module and make any necessary adjustment to the screw depth to ensure a secure fit. Install the two bottom screws in an alternating fashion.
9. Route the module cables under the bracket edge and toward the rear of the Mercury Instrument.
10. Mount the Module Mounting Bracket (Mercury Instrument part number 22-1077, included in the kit) onto the Mini-Max enclosure. Place a #8 metal flat washer followed by a rubber sealing washer onto both #8-32 x 3/8-inch screws. Align the lower threaded holes in the mounting bracket with the drilled enclosure holes and insert a screw/washer through the enclosure housing. Screws heads must be inside the enclosure. Tighten both screws using a screwdriver.

Note Aligning the second bracket threaded hole and drilled hole may require some manipulation of the mounting bracket.

11. Insert the module cables (both units) through the large cable strain relief on the left rear of the corrector's enclosure. Leave a one-half to one inch drip loop under the cable strain relief.
12. Secure three cable ties on the module cables in three places on the cables as specified by information included in the kit.
13. Re-install the input switchboard, main board, and battery pack removed in Step 2.

14. Connect the *corrected* module wires to TB1 on the Mini-Max board following the table below. Use Mercury upgrade kit 40-2678-1 to provide the second pulse output channel for the uncorrected module.

Corrected Module Connections

Module	Mini-Max TB1
Red wire	K terminal
Blue wire*	Ya terminal
White wire*	Ya terminal

*Twist the blue and white module wires together before connecting to the Mini-Max board.

Tighten terminal connections securely.

15. Connect the *uncorrected* module wires to the Input Switch Board UNC.VOL following the table below.

Uncorrected Module Connections

Endpoint	Mini-Max Input Switch Board UNC. Vol.
Red wire	COM terminal
Blue wire	NO terminal
White wire	NO terminal

*Twist the blue and white module wires together before connecting to the Mini-Max board.

16. Tighten terminal connections securely.
 17. Tighten the large strain relief securely.

Warning Do not crush the module through cables when tightening the strain relief.

18. Re-install or reconnect the power or battery sources.
 19. Close the instrument case and tighten the case screw securely. Replace any locks that were removed for installation.

Wiring the Remote Module to the Mercury TCI

The Mercury Instruments Temperature Compensating Index (TCI) provides two Form-A volume pulse outputs and one Form-B alarm output. These outputs are electronic switches. The first two pulse outputs are configurable for compensated or uncompensated volume. The third output (Form-B) is for alarm output use only.



Connections to the three output pulse channels are completed using loose unterminated wires (the individual wires from a cable) and gel-connectors. The TCI unit has six unterminated wires and six gel-connectors (Itron part number CON-0023-001) to enable pulse connections to ancillary devices. Loose wires are located inside the gray adapter plate behind the black strain relief fitting.



Adapter plate with black strain relief Loose cable wires

The three switch contacts on the TCI PC board are MOSFET output type opto-isolators that provide high voltage isolation between the sensitive processor components of the TCI board and the outside world.

Wire Color	Description	Function
Orange	Volume output channel A	Comp/uncomp volume pulse
Yellow	Volume output channel A	(configurable pulse timing)
White	Volume output channel B	Comp/uncomp volume pulse
Green	Volume Output channel B	(configurable pulse timing)
Brown	Alarm channel	Alarm event signal
Blue	Alarm channel	(Pulse timing)

To make TCI pulse connections

Note Connect one endpoint/channel to the alarm output if the endpoints are used on channels A and B.

Configuration for two endpoints connected to one TCI

Channel A

OWG-500x-504	TCI
White	Orange and brown
Red	Yellow
Blue	Blue (alarm)

Channel B

OWG-500x-504	TCI
White	White
Red	Green
Blue	White

1. Remove strain relief fitting by unscrewing from the gray adapter plate.



Note Do not remove the fitting's hex nut. Un-screw the entire fitting from the gray adapter plate. A tether line is secured to the strain relief fitting. When the strain relief fitting is removed, the tether line pulls the unterminated wires out of the adapter plate for access to the loose wires.

2. Loosen the strain relief fitting hex nut and remove the white plug from the center.
3. Place the strain relief fitting onto the field pulse cable.



4. If the field pulse cable is smaller than a 0.2-inch diameter, install the rubber tube supplied with the TCI onto the cable so the strain relief will clamp onto the tube after it is re-installed.



5. Connect the individual external pulse cable conductors to the un-terminated wires following *Configuration for two endpoints connected to one TCI* at the beginning of these instructions. Insert one un-terminated wire into an opening of a gel-connector (six gel-connectors were included with the TCI). Insert the appropriate field cable wire into the other gel-connector opening.



6. Verify both wires are fully inserted into the gel-connector prior to crimping.

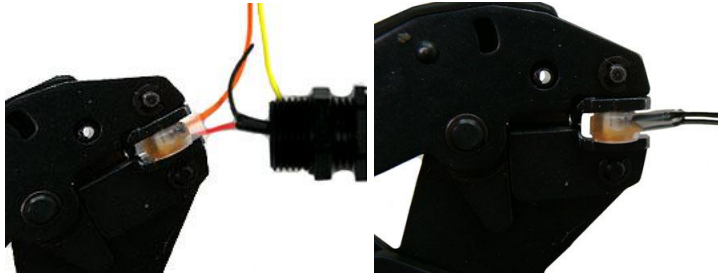

Important Use a crimping tool compatible with gel-connectors. *Do not* use a standard pliers for crimping gel-connects. The crimping tool provides an even pressured crimp to make a secure connection.

7. Insert the gel-connected wires into the threaded gray adapter plate hole.



8. Replace the strain relief and tighten until secure.

Connecting the OpenWay Remote Mount Gas Module to the Dresser ROOTS® IMC/W2 or MC2 Cable

You may ship the Itron 2.4GZ OpenWay remote mount gas module directly to Dresser ROOTS® Meters for a factory-installed cable. If you connect the module to the meter using an existing cable purchased from Dresser ROOTS®, complete the following cable installation procedure.



Caution The purchased cable must have a mating connector compatible with the IMC/W2 or MC2 receptacle. Dresser ROOTS® cables may be wired in different configurations for specific applications. If necessary, contact Dresser ROOTS® Meters for wiring diagrams for your specific application.

To connect the 2.4GZ OpenWay remote mount gas module to the IMC/W2 or MC2 cable

1. Remove the backplate (4 screws) from the 2.4GZ remote module and expose the endpoint lead wires. The backplate and screws will be re-installed on the endpoint module later in this procedure so store them (temporarily) in a safe, secure place.

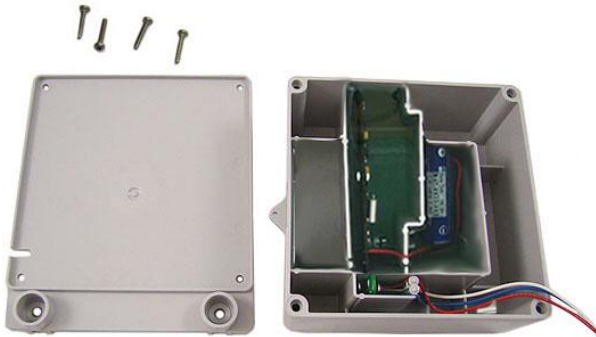

2. Insert the lead wires from the 2.4GZ OpenWay remote mount gas module into new 3M gel connectors (Itron part number CON-0023-001) together with the same colored lead wire from the meter cable (see the wiring table below) and crimp using a 3M hand-held crimping tool.

Important Use a crimping tool compatible with gel-connectors. *Do not* use a standard pliers for crimping gel-connects. The crimping tool provides an even pressured crimp to make a secure connection. Apply pressure for three seconds until the gel cap is fully crimped (collapsed) to allow time for the low viscosity silicone-based gel to flow. If the silicone gel flows out of the crimped connector, avoid touching the gel. Gel flowing from the connector provides environmental protection for the connection.

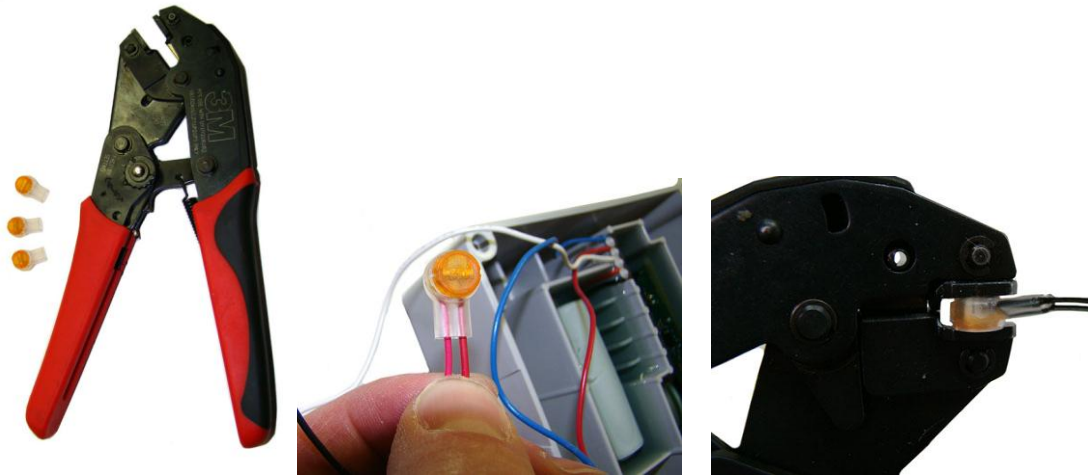

Note Do not strip lead wire prior to inserting the wire in the gel connector.

IMCW2 to Remote Endpoint Wire Table

IMCW2 Wire	Remote endpoint wire
Red	Red
White	White
Blue	Blue

3. Dresser ROOTS® IMC/W2 and MC2 cables are typically delivered with a cable tie installed. If the meter cable does not include a cable tie, install a tie to the cable just below the exposed colored lead wires on the cable insulation. Remove the excess cable tie using a hand-held sidecutter pliers. The cable tie performs as a cable strain relief to mitigate the risk of destructive tension on the lead wires.

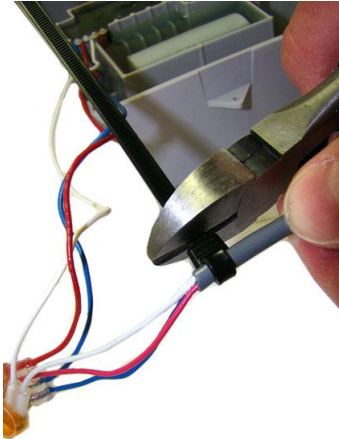

4. Tuck the three gel connectors and cable tie inside the endpoint housing, as shown. Position the cable tie as shown by the arrow in the position schematic below.

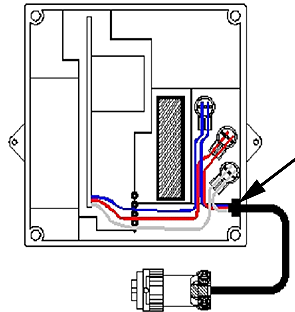
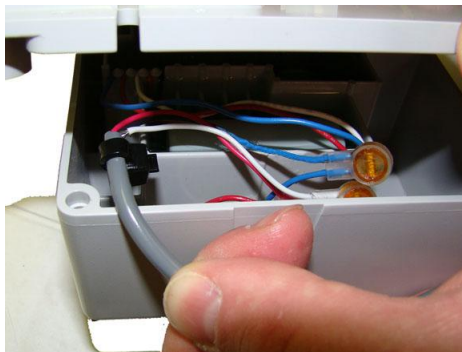

5. Install the 2.4GZ OpenWay remote mount gas module backplate using the four screws previously removed from the endpoint and a Torx T-15 screwdriver.

Important Verify the cable tie and gel connectors are inside the endpoint housing and the cable extends out of the slot in the backplate. Torque the backplate mounting screws to 9-12 inch-pounds.
