



**OpenWay Riva**

# **500G/550G/100G ERT Module Installation Guide**

**Includes direct- and remote-mount modules**

500G/550G/100G ERT Module Installation Guide  
August 13, 2024  
LDI-0005 REV 002

Copyright © 2024 Itron Inc. All rights reserved.

## Confidentiality notice

Confidential information of Itron Inc., provided under nondisclosure obligations. The information contained herein is proprietary and confidential and is being provided subject to the condition that (i) it be held in confidence except to the extent required otherwise by law and (ii) it will be used only for the purposes described herein. Any third party that is given access to this information shall be similarly bound in writing.

## Trademark notice

Itron® and the Itron logo, Actaris, ERT, OpenWay, Riva, and Temetra, are registered trademarks of Itron Inc. in the United States and/or other countries and regions. ChoiceConnect is a trademark of Itron Inc. in the United States and other countries and regions.

All other product names and logos in this documentation are used for identification purposes only and may be trademarks or registered trademarks of their respective companies.

For more information about Itron trademarks, go to [Itron's Trademarks and Brands](#).

## Contact us

For more information about Itron or Itron products, go to:

Email: [support@itron.com](mailto:support@itron.com)

Itron Customer Center: [customer.itron.com](http://customer.itron.com)

Products and documentation: [products.itron.com](http://products.itron.com)

Itron Technical Support North America: 1-877-487-6602

For regional technical support, go to [www.itron.com](http://www.itron.com) and select your country and language.

---

For suggestions, questions, or other feedback concerning Itron product documentation, contact us at: [ItronDocumentation@itron.com](mailto:ItronDocumentation@itron.com).

# Contents

<b>New in this document</b> .....	<b>7</b>
<b>1 Introduction</b> .....	<b>8</b>
Direct-mount modules versus remote-mount modules .....	8
About this document .....	9
Related documents .....	9
<b>2 Installation overview and prerequisites</b> .....	<b>11</b>
Installation prerequisites .....	11
Direct-mount module variant .....	12
Remote-mount module variant .....	14
Diaphragm meter .....	14
Eagle Research meter .....	16
Elster American meter .....	16
Galvanic Gas Micro meter .....	17
Dresser (GE Oil and Gas) meter .....	17
Honeywell Instrument .....	18
Itron meter .....	18
National meter .....	18
Romet meter .....	18
Sensus meter .....	19
<b>3 Direct-mount installation</b> .....	<b>20</b>
Residential meters .....	20
Elster American .....	20
Itron/Sprague .....	27
National (Lancaster) .....	43
Romet rotary meter .....	50
Sensus/Rockwell .....	52
Commercial meters .....	58
Elster American Installation .....	59
Dresser (GE Oil and Gas) .....	64
Itron/Sprague .....	69
Romet rotary meter .....	75

Sensus/Rockwell installation .....	76
<b>4 Remote-mount installation .....</b>	<b>82</b>
Diaphragm meter .....	82
Wiring instructions .....	83
Dresser (GE Oil and Gas) .....	90
Programming .....	92
Wiring instructions .....	93
Custom mounting options .....	101
Eagle Research .....	104
MPplus Corrector programming .....	104
XARTU Corrector programming .....	107
Wiring instructions .....	109
Mounting with Eagle Research mounting rail .....	112
Elster American .....	114
Wiring instructions .....	114
Mounting with Elster American-specific mounting method .....	117
Galvanic Gas Micro .....	120
Mechanical and wiring installation instructions .....	120
Mounting instructions .....	120
Honeywell Instrument .....	120
Programming .....	122
Wiring instructions .....	126
Mounting with Honeywell-specific setup .....	131
Itron Meter .....	133
National meter .....	133
Romet meter .....	133
AdEM programming .....	134
Wiring instructions .....	137
Mounting with Romet ECM2 kit .....	142
Sensus meter .....	144
Sensus programming .....	144
Wiring instructions .....	145
Mounting with Sensus-specific kit .....	145
<b>5 Programming and verifying .....</b>	<b>147</b>

ltron programs and software variables .....	148
Field Deployment Manager (FDM) .....	148
Mercury X-Blank options .....	150
Check Endpoint functions .....	151
Field Collection System (FCS) (mobile mode only) .....	151
OpenWay Collection Manager (OWCM) .....	151
Field Tools .....	151
Standard configuration and battery life .....	151
Verifying operation .....	152
Check Endpoint (FDM) .....	152
Check (Field Tools) .....	153
After programming .....	154
<b>6 Mounting a remote-mount module .....</b>	<b>156</b>
Standard installation options .....	156
Mounting to a pipe .....	157
To install .....	157
Adapter plate mounting positions .....	159
Mounting on a flat vertical location .....	160
<b>7 Using gel-cap connectors to complete wiring connections .....</b>	<b>163</b>
<b>8 Optional sealant application instructions .....</b>	<b>165</b>
<b>A Important safety and compliance information .....</b>	<b>167</b>
U.S. and Canadian patent numbers .....	167
U.S. patent numbers .....	167
Canadian patent numbers .....	167
USA, FCC Part 15 spectrum compliance .....	167
USA, FCC Class B-Part 15 .....	167
Modifications and repairs .....	168
Canada, ISED spectrum compliance .....	168
RF exposure (FCC/ISED) .....	169
Australia, ACMA spectrum compliance .....	169
Transportation classification .....	169
Modifications, repairs, installation, and removal .....	169
Lithium battery safety .....	169

Equipment repairs .....	170
Intrinsic safety .....	170
Electrostatic ignition hazard .....	170
Module cleaning .....	170
Do not drop .....	170

# New in this document

Revision	Date	Description
REV 002	August 2024	<p>This document, formerly titled <i>OpenWay® Riva 500G/550G/100G ERT® Module Remote Mount Installation Guide</i> (part number LDI-0005) with <i>OpenWay® Riva 500G/550G/100G ERT® Module Direct Mount Installation Guide</i> (part number LDI-0006). This document is now called <i>OpenWay Riva 500G/550G/100G ERT Module Installation Guide</i> and is tracked under part number LDI-0005. The document associated with part number LDI-0006 has been archived.</p> <ul style="list-style-type: none"> <li>■ Reorganized information</li> <li>■ Added the following part numbers series where appropriate: <ul style="list-style-type: none"> <li>– ERG-5600-xxx</li> <li>– ERG-7600-xxx</li> </ul> </li> </ul>
REV 001	October 3, 2022	<ul style="list-style-type: none"> <li>■ Added notes to <a href="#">Dresser (GE Oil and Gas) on page 90</a></li> </ul>
REV 000	May 24, 2022	<ul style="list-style-type: none"> <li>■ This document was formerly part of the <i>500G and 550G ERT® Module Installation Guide, Remote Mount</i> (part number 815-0447-00), which has been separated into the following documents: <ul style="list-style-type: none"> <li>– <i>OpenWay® Riva 500G/550G/100G ERT® Module Remote Mount Installation Guide</i> (part number LDI-0005) (this document)</li> <li>– <i>GenX 500G/550G ERT® Module Remote Mount Installation Guide</i> (part number LDI-0007)</li> </ul> </li> <li>■ Updates to <a href="#">Installation overview and prerequisites on page 11</a>, including clarification of part numbers for <a href="#">Residential meters on page 20</a> and <a href="#">Commercial meters on page 58</a>.</li> <li>■ Added information for the 100G ERT Module.</li> <li>■ Moved <a href="#">Important safety and compliance information on page 167</a> to end of document</li> <li>■ Improved structure and flow of document.</li> </ul>

# 1

## Introduction

This guide describes the procedures for direct-mount and remount-mount installing the following Itron gas ERT Modules:

- OpenWay Riva 500G ERT Module
- OpenWay Riva 550G ERT Module
- 100G DLS Datalogging ERT Module

Itron remote mount and direct mount 500G and 550G ERT Modules (here forward referred to as 500G ERT Modules, unless specified otherwise) are radio-frequency (RF) IPv6 open standards-based gas modules designed to be read under Itron's multi-purpose network mode or by legacy ChoiceConnect mobile mode. In network mode, the ERT Module offers firmware download, sub-hourly interval data, and extended data storage. In mobile mode, the ERT Module operates identically to the 100G DLS Datalogging ERT Module. In either case, ERT Modules can be read by legacy handhelds and mobile or the newer Itron Mobile Radio readers.

Itron's 100G DLS Datalogging ERT Module (hereafter referred to as 100G ERT Module) is an RF device designed to transmit meter data to an RF meter reading device within transmission distance of the 100G ERT Module. The 100G ERT Module was designed with a higher output power than earlier 100G ERT Modules to achieve an increased RF transmission distance. The 100G ERT Modules have greater output power to meet Itron mobile and fixed network requirements. Additionally, product development included a generational progression of enhancements, featuring reduced infrastructure costs, increased efficiency in standard consumption messaging (SCM+), enhanced security, and more.

The 500G ERT Modules and the 100G ERT Module share a lot in common. When something is true for all three products, this document refers to the entire collection of variants as "ERT Modules." Additionally, the ERT Modules have several types of housing and labeling. Only some variants are pictured in this document.

## Direct-mount modules versus remote-mount modules

The direct-mount residential and direct-mount commercial ERT Modules transmit on a radio frequency and attach directly to gas meters to collect consumption usage, event, and alarm data. It is an IPv4-compliant endpoint designed to communicate over Itron's OpenWay multi-purpose IoT solution, transmitting in network mode or mobile mode.



Designed for meters for which Itron does not sell direct-mount ERT Modules, the remote-mount ERT Module mounts away (remotely) from the gas meter it is reading. Remote-mount modules are IP65 rated, designed with the possibility of UV exposure in mind, and are useful for locations where placing the module in a high location improves reception. All remote-mount modules can be installed indoors or outdoors, on a wall or on a pole. Like the direct-mount variant, remote-mounts also communicate over Itron's OpenWay multi-purpose IoT solution, transmitting in network mode or mobile mode.

Each variant has their own set of installation methods associated with them, which are described further in [Installation overview and prerequisites on page 11](#).

## About this document

This document describes the installation requirements and procedures for direct-mount and remote-mount ERT Modules. Readers can also find troubleshooting procedures and best practices for ERT Module installation.

## Related documents

The following documents may also be useful to readers. These documents and others can be accessed and viewed on <https://products.itron.com>.

- *ERT Module Technical Reference Guide*
- *Customer setup to order secured OpenWay Riva Modules*
- *FDM Tools Configuration Guide*
- *FDM Tools Field Representative Guide*
- *FDM Tools Mobile Application Guide*
- [FDM Tools Mobile Application Online Help](#)
- [Field Tools Online Help](#)
- *First article review form*
- *Gas Devices Ordering Guide*
- *Gas Module Compatibility Matrix*
- *Itron Mobile Radio (IMR) Quick Reference Guide*
- *Itron Mobile Radio (IMR) User Guide*
- *OpenWay Collection Manager Device Interface Guide*
- *OpenWay Collection Manager Device Interface Guide*
- *OpenWay Riva 500G ERT Module Specification Sheet*

- *OpenWay Riva 500G/550G ERT Module Technical Reference Guide*
- *OpenWay Riva Gas Devices Ordering Guide*

# 2

## Installation overview and prerequisites

Installing a ERT Module involves several steps, which vary in number depending on whether you are installing via Itron's Zero Touch Deployment (ZTD) method. ZTD is a process for installing and commissioning gas ERT Modules to be read by the head end system (which does not require on-site configuration). This means that only "screwdriver" work is required at the meter site. ZTD requires that the modules be pre-programmed with the necessary operating parameters in the meter shop or in a factory. For gas modules, this generally requires replacing the meter's existing index with a zeroed index.

1. Connect and initialize the ERT Module to the gas meter register.
2. Install/mount the ERT Module. This process varies based on the module variant (direct-mount or remote-mount) and location. The utility is responsible for identifying which method is best for the environment in which they are installing their ERT Module.
3. Install accessories as needed.
4. *(If not installing with ZTD)* Program the ERT Module. You can do this with either Field Tools or FDM (for specific details on programming requirements, see [Installation prerequisites on page 11.](#))
5. Verify operation by performing a **Check Endpoint** (if using FDM) or **Check** (if using Field Tools).

### Installation prerequisites

To ensure a successful installation, you must first identify and assemble some required tools. The materials required for your installation vary based on the module variant you are installing and where you are installing it.

Start by identifying which kind of module you are installing:

- [Direct-mount module variant on page 12](#)
- [Remote-mount module variant on page 14](#)

All ERT Module installations require the following:

- An ERT Module. See the *Gas Devices Ordering Guide* for your module's specific part number.
- One of the following meter-reader application and device combinations:
  - **Field Tools** software on a user-supplied smartphone, laptop, or tablet running one of the following operating systems:

- iOS® 14 – 16.5.1.
- Android® 11.0 – 13.
- Windows® 10 or 11.

For Field Tools programming instructions, see the [Field Tools Online Help](#).

– **Field Deployment Manager (FDM) version 4.0** or later running on either:

- A FC300SR handheld computer.
- A supported Itron Mobile Radio (IMR) connected to a user-supplied computer or Bluetooth® device. Supported IMRs include:
  - IMR2 (supports 40G Wakeup).
  - IMR – Field Tools version (IMR-FT).

For FDM programming instructions, see the [Field Tools Online Help](#).

- Security material. ERT Modules operating with security, security materials (signed authorizations, secure commands, keys, and so on) must be passed along from the FDM Tools server to your Field Tools or FDM Tools mobile application during the sync process.

Your mobile device running FDM Tools or Field Tools must have an internet connection to request commands. If you aren't sure that you will be able to connect to the internet while out in the field, be sure to request all necessary commands before going out in the field.

- If using Field Tools: See the [Request commands](#) section in the [Field Tools Online Help](#) documentation.
- If using FDM: See the [Retrieving Secure Commands from the FDM Server](#) section in the *FDM Tools Mobile Application Guide*.

## Direct-mount module variant

In addition to the items listed in [Installation prerequisites on page 11](#), all direct-mount ERT Module installations require the following:

- A flat-head screwdriver

**Note:** Some meters may also require Phillips screws. A #2 Phillips screwdriver can be used in these cases.

- A scraping tool
- An index compatible with your gas meter
- Small and medium flat-blade or Phillips screwdrivers
- Side-cutting pliers or wire snips
- 11/32-inch nut driver or other blunt tool

**Table 1** Replacement screw information

Meter	To mount the ERT Module on the meter:	Itron part number	To mount the index on the ERT Module (and index assembly, if applicable), on the module's housing:	Itron part number
Elster American (residential)	1/4-20 by 0.625 (5/8) inch slotted, Fillister head	N/A	8-32 by 0.19 (3/16) inch slotted, Fillister head	N/A
Sensus/ Rockwell (residential)	10-24 by 0.625 (5/8) inch slotted, Fillister head	N/A	6-32 by 0.625 (5/8) inch slotted, Fillister head	N/A
Elster American (commercial)	2A by 3.35 inch length, slotted round-head drilled to accept utility-approved wire seals 0.294-18 UNS by 4-3/16, slotted round-head drilled to accept utility-approved wire seals	SCR-0062-001 400-480-00	12 - 24 by 1/2 inch slotted, Fillister head machine screws, drilled to accept utility-approved wire seals N/A	N/A
Sensus/ Rockwell (commercial)	2A by 3.63 inch length, slotted round-head drilled to accept utility-approved wire seals 4/16-18 by 4.56 inch length, slotted round-head drilled to accept utility-approved wire seals	SCR-0062-002 400-0481-00	2A by 2.94 inch length, slotted round-head 5/16-18 by 3.8 inch length, slotted round-head drilled to accept utility-approved wire seals	SCR-0062-003 400-482-00
Itron/ Sprague (residential)	Longer mounting screw is required when retrofitting to METRIS 250, METRIS RM, and METRIS MB.	010626-002	N/A	N/A
Itron/ Sprague (commercial)	4 each of 1/4-20-inch screws.	400-483-00	N/A	N/A

- (If installing to a Itron/Sprague meter 1A or 240) Itron Adapter Plate kit (CFG-0015-001)
- (If installing to a Sprague top mount meter) Itron Adapter Plate kit (80005901-001)

- *(Optional)* Meter seals
- *(Optional)* Wire seal
- *(Optional)* Seal press

As direct-mount ERT Modules can only work with meters up to 18RPM, gear reduction boxes may be necessary.

## Remote-mount module variant

In addition to the items listed in [Installation prerequisites on page 11](#), all remote-mount ERT Module installations require the following:

- Wire termination tools, including:
  - 3M<sup>®</sup> E-9E gel connector crimping tool (or other 3M-approved crimping tool).
  - Itron splice kit (part number OEM-0034-002).
- *(Only if mounting to a pipe)* Itron pipe mount kit (part number CFG-0005-003)
- *(Optional, where insect intrusion may be a problem)* Sealant (part number ADH-5106-000)

Review the installation overview and requirements for your specific meter. The ERT Module can be remote mounted on the following meters:

- Diaphragm meter on [page 14](#)
- Eagle Research meter on [page 16](#)
- Elster American meter on [page 16](#)
- Galvanic Gas Micro meter on [page 17](#)
- Dresser (GE Oil and Gas) meter on [page 17](#)
- Honeywell Instrument on [page 18](#)
- Itron meter on [page 18](#)
- National meter on [page 18](#)
- Romet meter on [page 18](#)
- Sensus meter on [page 19](#)

## Diaphragm meter

In addition to the items listed in [Installation overview and prerequisites on page 11](#) and [Remote-mount module variant on page 14](#), the following materials are required for each ERT Module installation to a Diaphragm gas meter. Purchase these items from Itron:

- Remote mount encoder kit part number (part number CFG-0081-001)
- Encoder spacing tool (part number 013-1723-112)

Use the Encoder Spacing Tool to ensure that the encoder mounts the correct distance from the magnet hub on the meter index.

You also need:

- A #2 Philips-head screwdriver
- Sharp, side-cutting pliers
- Cable tie for cable-strain relief
- Any required utility-approved security seals and wires

The Itron replacement index cover gaskets shown below are thicker than standard gaskets and have a special slot to accommodate the encoder cable. Gaskets are designed for Schlumberger/Sprague model 675 and 1000 commercial diaphragm meters. These gaskets may be incompatible on meters from other manufacturers; alternate cable relief procedures may be necessary.

- Four-hole front cover gasket (part number FAB-0014-003)



- Two-hole front cover gasket (part number FAB-0014-002)



- One-hole front cover gasket (part number FAB-0014-001)



Once you have gathered the needed materials for your installation, continue to [Remote-mount installation on page 82](#).

## Eagle Research meter

In addition to the items listed in [Installation overview and prerequisites on page 11](#) and [Remote-mount module variant on page 14](#), the following materials are required for each ERT Module installation to a Eagle Research gas meter:

- A computer loaded with the Eagle Research Software and an Eagle Research computer-to-volume corrector communication cable.
- *(Only if mounting to a custom Eagle Research mount)* Eagle Research mounting rail (contact Eagle Research for part number)
- Wire stripper
- Flat-tip screwdriver sized to tighten the terminal connections on the Eagle corrector

Once you have gathered the needed materials for your installation, continue to [Remote-mount installation on page 82](#).

## Elster American meter

In addition to the items listed in [Installation overview and prerequisites on page 11](#) and [Remote-mount module variant on page 14](#), the following materials are required for each ERT Module installation to a Elster American gas meter. Purchase these items from Itron:

- 3M gel-cap connectors (Itron part number CON-0023-001)
- If installing an ERT Module (including part numbers ERG-5006-501, ERG-5600-501, ERG-7000-501, and ERG-7600-501)
  - Remote mount encoder kit part number (part number CFG-0081-001)
  - Encoder spacing tool (part number 013-1723-112)

Use the Encoder Spacing Tool to ensure that the encoder mounts the correct distance from the magnet hub on the meter index.

You also need:

- Cable tie for cable-strain relief
- Wire stripper
- Wire cutter
- Flat-tip screwdriver
- T-10 Torx screwdriver
- Computer communication cable
- E-9R 3M gel-cap crimping tool
- *(If using the Elster American meter mounting option)* Elster American's mounting kit (contact Elster American for part number)



Once you have gathered the needed materials for your installation, continue to [Remote-mount installation on page 82](#).

## Galvanic Gas Micro meter

In addition to the items listed in [Installation overview and prerequisites on page 11](#) and [Remote-mount module variant on page 14](#), the following materials are required for each ERT Module installation to a Galvanic Gas Micro gas meter:

- Wire stripper
- Flat-tip screwdriver sized to tighten the terminal connections on the Galvanic corrector
- Computer communication cable
- Gas Micro IMACS® Windows PC software

When you have gathered the needed materials for your installation, continue to [Remote-mount installation on page 82](#).

## Dresser (GE Oil and Gas) meter

In addition to the items listed in [Installation overview and prerequisites on page 11](#) and [Remote-mount module variant on page 14](#), the following materials are required for each ERT Module installation to a Dresser gas meter. Purchase these items from Itron:

- 3M gel-cap connectors (Itron part number CON-0023-001)

You also need:

- X-Acto® knife or similar cutting tool
- T15 Torx screwdriver
- T10 Torx screwdriver
- E-9R 3M gel-cap crimping tool
- Cable tie for cable-strain relief
- *(If installing with the D800/D1000 mounting solution)* The following screws and nuts:
  - One 8-32 by 1/2 inch screw
  - Two 8-32 by 1/2 inch screws
  - Three 8-32 inch Kep® nuts
- *(If installing with IMC/W2 or MC2)* Dresser mounting bracket kit (contact Dresser for appropriate part number) which includes:
  - One mounting bracket
  - One 8-32 by 7/16 inch screw
  - Two 8-32 by 3/4 inch screws

- Three 8-32 nuts
- Four #10 spacers
- Five M6 by 20 millimeters ERT Module/bracket mounting screws

Once you have gathered the needed materials for your installation, continue to [Remote-mount installation on page 82](#).

## Honeywell Instrument

The following materials are required for each ERT Module installation to a Honeywell Instrument:

- #2 Phillips-head screwdriver
- Wire stripper
- Honeywell software (for programming). See Honeywell product and software documentation for the correct software and version requirements.
- *(Only if using custom Honeywell mounting):*
  - Honeywell Kit (contact Honeywell for part number)
  - Three #8-32 by 1/2 inch screws
  - Three #8 metal flat washers
  - Three rubber sealing washers

Once you have gathered the needed materials for your installation, continue to [Remote-mount installation on page 82](#).

## Itron meter

The Itron meter is installed in the same manner as the Diaphragm meter. For requirements, see [Diaphragm meter on page 14](#).

## National meter

The Itron meter is installed in the same manner as the Diaphragm meter. For requirements, see [Diaphragm meter on page 14](#).

## Romet meter

In addition to the items listed in [Installation overview and prerequisites on page 11](#) and [Remote-mount module variant on page 14](#), the following materials are required for each ERT Module installation to a Romet gas meter. Purchase these items from Itron:

- Three gel cap connectors (part number CON-0023-001)

You also need:

- Tools with which to connect the ERT Module to the corrector:
  - Connection options, Cannon cable, pigtail option (contact Romet for part number)
  - Romet AdEM computer-to-corrector communication cable (contact Romet for part number)
  - Computer loaded with RometLink communication software
  - 3M crimping tool
  - Torx T-10 screwdriver
- *(Only if using custom Romet mounting option)* Romet mounting kit (contact Romet for part number)

Once you have gathered the needed materials for your installation, continue to [Remote-mount installation on page 82](#).

## Sensus meter

In addition to the items listed in [Installation overview and prerequisites on page 11](#) and [Remote-mount module variant on page 14](#), the following materials are required for each ERT Module installation to a Sensus gas meter. Order the correct Sensus Sonix direct-mount bracket for your installation requirements from Sensus North American Gas Customer Service, including:

- 1.5-inch foiled twisted pairs (FTP), 45 low tension (Lt), #3 Spg, 60Lt, #4 Spg
- 2-inch 11BS, 2-inch FTP
- 30Lt, #1A Spg, 1.25-inch National Pipe Thread (NPT), #2 Spg, 20Lt
- #8-32 by 0.75-inch sterling silver Fillister-head screws (two required) (Sensus part number 903376 )
- Rubber mounting washer (stabilizes bracket and remote module assembly)

Contact Sensus for appropriate part numbers.

Once you have gathered the needed materials for your installation, continue to [Remote-mount installation on page 82](#).

# 3

## Direct-mount installation

Installing the ERT Module to a gas meter involves four general tasks:

1. Removing the gas meter's index cover and preparing the meter for installation.
2. Attaching/connecting the ERT Module to the meter.
3. Programming the ERT Module.

Module programming is dependent on your system application. See your gas meter's documentation for more information.

4. Re-assembling the index and ERT Module.

This chapter provides ERT Module direct-mount installation procedures for:

- Residential meters on page 20
- Commercial meters on page 58

### Residential meters

This section describes the installation procedures for direct-mounted ERT Modules on residential gas meters, including:

- Elster American on page 20
- Itron/Sprague on page 27
- National (Lancaster) on page 43
- Romet rotary meter on page 75
- Sensus/Rockwell on page 52

### Elster American

This section provides instructions to install the ERT Module (including part numbers ERG-5006-001, ERG-5600-001, ERG-7000-001, and ERG-7600-001) on compatible Elster American meters. Compatible meters include:

- 5B-225 aluminum case

**Note:** You must cut 1/16 inch off the end of each of the ERT Module wiggler drive posts (there are three). Cutting the posts to fit the 5B-225 aluminum case makes the ERT Module incompatible with other two-foot drive meters.

- AC-800 aluminum case

- AC-630 aluminum case
- AC-250 aluminum case
- AC-175 aluminum case
- AL-425 aluminum case
- AL-350 aluminum case
- AL-310 aluminum case
- AL-250 aluminum case
- AL-225, Canada-only aluminum case
- AL-175 aluminum case
- ALC-175 aluminum case
- AM-250 aluminum case
- AR-250 aluminum case
- AT-250 aluminum case
- AT-210 aluminum case
- AT-175 aluminum case
- Rotary RPM series (instrument drive)
- Rotary RPM Series (no pulser, no instrument drive)
- W75AL aluminum case

Some meter manufacturers provide mounting kits and installation procedures for their meters. If the Elster American meter to the ERT Module installation instructions are not available, follow the installation procedures in this section.

The following figure shows a ERT Module that is compatible with Elster American meters.



## Connecting instructions

1. Remove the four index cover screws and the index cover from the Elster American residential meter. Alternate screw removal following the numbered pattern in the photo.



2. Examine the mounting screws. If they are 5/8 inch long and not corroded, keep them to install the module assembly to the meter. If the screws are not the correct length or if the screws are corroded, discard.



3. Unscrew one index mounting screw completely.  
Hold one hand under the index to catch the screw. While you remove the other mounting screw, pull the index away from the meter to keep the index backplate against the back of the screw. Remove the screw completely after the index is free of the meter.
4. Set the index and index screws aside. You will mount the index to the module later in this procedure.
5. Verify that the index mounting screws are 3/16 inch long and not corroded. If the screws are the correct length and not corroded, retain for later use. If you discarded the original screws, use the correct replacement screws. For replacement screw information, see [Direct-mount module variant on page 12](#).
6. Remove the old gasket, gasket residue and dirt from the meter (if applicable). The meter face must be free of gasket residue and foreign materials before you install the module.



7. Separate the module housing from the cover by pulling the cover straight out from the housing.



If your index has mounting screw slots, skip steps 8 and 9. If your index has mounting screw holes, perform steps 8 and 9, and skip steps 10 and 11.

<p><b>Index wrigglers on one foot meters with drive slots</b></p>	<p><b>Index with mounting screw holes</b></p>



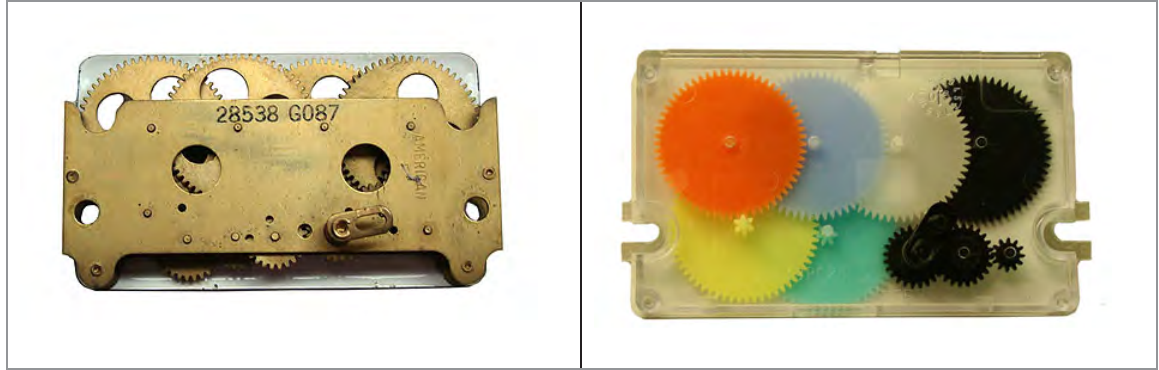

8. Set the module clear cover aside where it will not be damaged or fill with rain, dirt, or snow. You will use the cover later in this installation procedure.
9. Using the original index mounting screw or a replacement screw, if necessary, place one 8 - 32 3/16 inch screw into one of the index's mounting screw holes.



10. Attach the screw to the module housing's index mounting post just enough to hold the screw and the end of the index in place.



11. Screw one 8-32 by 3/16 inch screw into the other index mounting post loosely—one or two turns. Do not tighten the screw.
12. For indexes with mounting slots, place the index mounting screw slot under the screw head. Do not tighten the screw.
13. Slide the index drive post into the module shaft slot. Verify positive engagement.





**Caution:** If the index wiggler has a drive slot, place the module shaft drive post into the index drive slot. Failure to mate the module shaft with the index drive post (or slot) can cause binding and lead to poor registration or meter failure.

14. Install and tighten the other index mounting screw (for indexes with either mounting screw slots or holes). Tighten the previously installed index mounting screw. Install and tighten index mounting screws evenly.
15. Slide the module cover over the index and housing. Verify the cover is installed correctly. The module's label should be clearly visible and easily read.



16. Complete necessary paperwork and verify that all excess materials are removed from the customer premises.
17. Review the following notes before continuing to [Programming and verifying on page 147](#).

The ERT Module is programmed based on the meter's drive rate. Take note of the index drive rate shown on a lower dial on the index. Elster American meter index drive rates are either cubic foot, two cubic feet, or 0.05 cubic meters (not shown below).

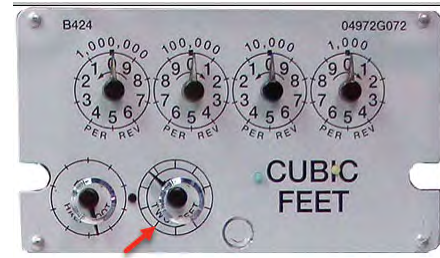
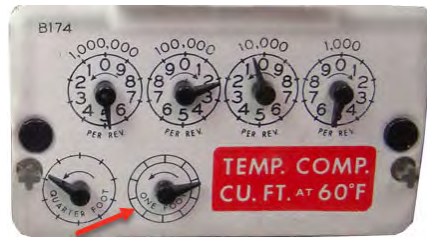

## Reassembling the index on Elster American meters

This procedure assumes you have programmed your module, as described in [Programming and verifying on page 147](#).

1. (For 5B-225 aluminum meters only) Cut 1/16 inch off each ERT Module's wiggler post to prevent the wiggler from rubbing on the face of the nut holding the meter drive dog in place. Trimming the drive post may make the module incompatible with other two-foot drive meters.



2. Align the ERT Module wiggler to connect with the drive post (or slot) of the meter.



**Warning!** Failure to correctly align the meter drive post and ERT Module drive slot can cause binding and lead to poor registration or meter failure. If there is a gap between the ERT Module gasket and the meter, it may be the drive slot of the ERT Module assembly's wiggler is not correctly aligned with the meter drive slot. Remove the ERT Module assembly and repeat the alignment procedure. You must engage the ERT Module wiggler with the meter drive dog.

- For one-foot meters: Align the ERT Module assembly wiggler perpendicular to the meter drive post.

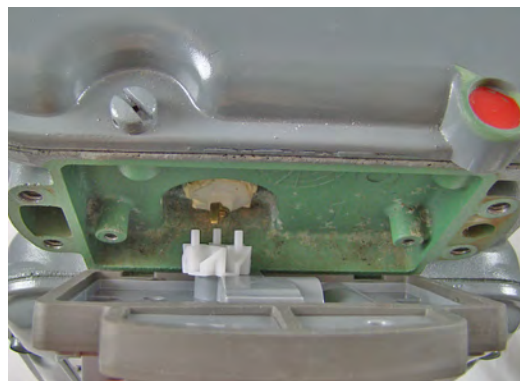

- For two-foot meters: Align the ERT Module assembly wriggler perpendicular to the meter drive slot. The pin on the ERT Module wriggler may be installed inside or outside the meter drive slot. For easy assembly, Itron recommends installing the pin on the module's wriggler outside the meter drive slot.

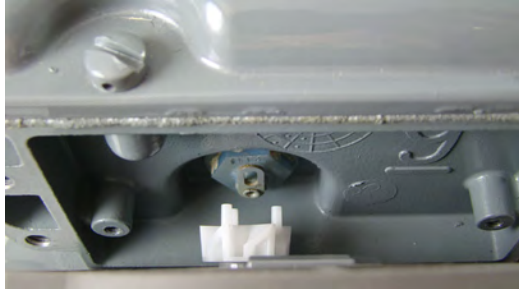

3. Carefully align the ERT Module's four screw holes with the holes on the meter. Attach the assembly using the original mounting screws if they are the correct size and are not corroded (1/4 - 20 by 5/8 inch screws.) If you discarded the original screws, use the correct replacement screws. Tighten the screws a quarter to a half turn in the order shown in the illustration in step 1.
4. Return to the first screw and tighten. Continue with the second, third, and last screw until all screws are tight. Use equal screw torque to tighten each screw. Torque the mounting screws 15 to 20 inch-pounds.
5. Place new tamper seals over the two screws with tamper seal mounts. Press tamper seals into place using an 11/32 inch nut driver or similar blunt tool.
6. Complete necessary paperwork and verify that all excess materials are removed from the customer premises.



**Important!** Modules ordered pre-programmed with security injected and specified as Zero Touch Deployment require that the installer rotate the wriggler five times to activate the ERT Module if installing in a location with little or no gas flow.

Installation of the ERT Module on the Elster American meter is complete.

## Itron/Sprague

Itron meters are also known as Actaris, Schlumberger, or Sprague meters. For these instructions, all meters will be referred to as Itron meters.

This section describes installing the ERT Module (including part numbers ERG-5006-005, ERG-5600-005, ERG-7000-005, and ERG-7600-005) on the following compatible commercial Itron/Sprague meters:

- 1A
  - Flat-face meter includes three-dial, two cubic feet indexes
  - Installation requires the Itron Adapter Kit (CFG-0015-001).
- 175
  - Three-hole index cover
  - Two-hole index cover
- 175 combination
  - Three-hole index cover
  - Integrated regulator
  - Two-hole index cover
- 175RM
  - Flat-face meter regulator on back of meter
  - Compatible only with ERG-5006-009, ERG-5600-009, ERG-7000-009, and ERG-7600-009
- 175WC
  - Three-hole index cover
- 210
  - Slant-face meter
- 240
  - Flat-face meter
  - One-hole index cover
  - Installation requires the Itron Adapter Kit (CFG-0015-001)
- 240
  - Slant-face meter
  - Two-hole index cover
- 240 combination
  - Integrated regulator
- 250
  - Slant-face
- 250WC
  - Integrated regulator

- 305 combination
  - Integrated regulator
- 400
  - Slant-face meter
- 400A
  - Slant-face meter
- I-250
  - Slant-face
- METRIS 250
  - Slant-face meter
  - A longer mounting screw is required when retrofitting to METRIS meters. Order from Itron using part number 010626-002.
- METRIS MB
  - Slant-face meter, back inlet and outlet without regulator
  - A longer mounting screw is required when retrofitting to METRIS meters. Order from Itron using part number 010626-002.
- METRIS RM
  - Slant-face meter, back inlet and outlet
  - A longer mounting screw is required when retrofitting to METRIS meters. Order from Itron using part number 010626-002.

ERT Module configuration with the meter is dependent on your system application.

### Connecting on a slant-faced meter

This procedure describes installing the ERT Module on a slant-faced Sprague meter. If you are installing the ERT Module on a flat-faced Sprague meter, see [Connecting on a flat-faced Sprague meter on page 33](#).

**Note:** The module depicted below may vary slightly in appearance from the ERT Module you are installing.

1. Remove the index cover screws and the index cover from the Itron meter.



2. Examine the mounting screws. If they are 5/8 inch long and not corroded, keep them to re-attach the ERT Module assembly. If the screws are not the correct length or if the screws are corroded, discard them.
3. Loosen the index mounting screws half to one turn.
4. Slide the index to the left and off the mounting screws.



5. Remove the index and index screws from the meter and set aside for later use. If the screws are damaged or corroded, replace them with the proper replacement screws. For replacement screw information, see [Direct-mount module variant on page 12](#).
6. Remove the old gasket, gasket residue, and dirt from the meter (if applicable). The meter face must be free of gasket residue or dirt before you install the ERT Module.





7. Separate the ERT Module housing from the cover by pulling the cover straight out from the housing. Set the ERT Module cover aside for use later in this installation procedure.



8. Insert the 10-24 x 3/8 inch screws (removed in step 5) into the index mounting posts two turns. Do not tighten the screws.

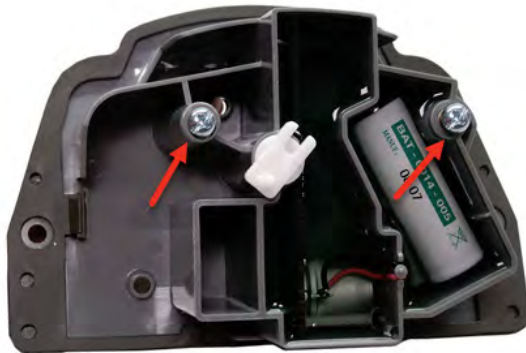

9. Align the index wiggler (1) with the drive post of the ERT Module shaft (2). Carefully slide the index onto the mounting screws.

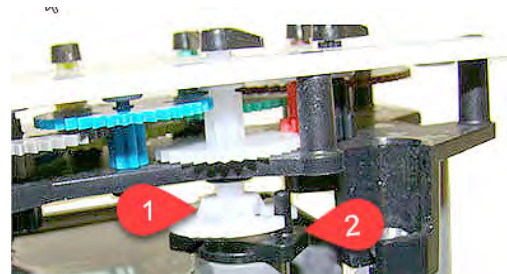
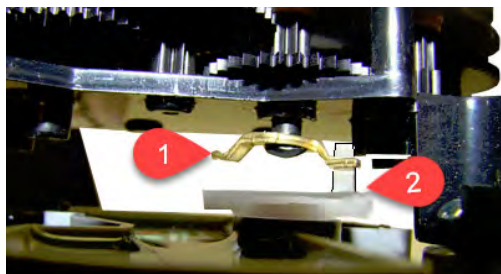

10. Verify that the module's shaft drive post makes positive engagement with the index wiggler.



**Warning!** Indexes have varying drive mechanism styles. Failure to align the ERT Module shaft with the index drive post can cause binding and lead to poor registration or meter failure. To verify proper engagement of the index to the ERT Module shaft, spin the wriggler one clockwise rotation, then one-counterclockwise rotation. Do not spin the wriggler more than one complete rotation. The wriggler should spin freely, with little or no resistance.

11. Hold the index in place and tighten the index mounting screws.



**Warning!** Verify that the index is correctly positioned all the way to the right on the index mounting screws before you tighten the index mounting screws. Failure to properly mount the index on the index mounting screws may cause binding and meter failure.



12. Slide the ERT Module cover over the index and housing. Verify the cover is installed correctly. The ERT Module label should be clearly visible and easily read.



13. Review the following notes before continuing to [Programming and verifying on page 147](#).  
The ERT Module is programmed based on the meter's drive rate. Take note of the index drive rate shown on the drive dial on the index. The ERT Module is programmed based on the drive rate.

Itron residential meter index drive rates are typically two cubic feet.



## Connecting on a flat-faced Sprague meter

ERT Module installation on a flat-faced Sprague meter requires the Itron Adapter Plate kit (CFG-0015-001).

The adapter plate must fit flush against the meter face. Some older Sprague meters are not compatible with the adapter plate. The following examples illustrate potential obstruction (problem) areas between the adapter plate and meter. Failure to mount the adapter plate flush on the front of a meter could result in a binding condition and lead to poor registration or meter failure.



1. Remove the drive dog from the flat-faced Sprague meter. Replace it with the extended drive dog included in the kit. Hand-tighten to snug.



**Warning!** A gasket surrounds the meter drive dog shaft. A gas leak could result if the gasket is damaged. Do not use a tool to install or tighten the new drive dog. Hand-tighten only.

2. Attach the adapter plate to the meter with the gasket against the meter face. Secure the plate to the meter with the two adapter plate mounting screws. Tighten the screws in an alternating pattern.
  - a. Insert the right adapter plate screw and tighten the screw enough to hold it in place.
  - b. Install the left mounting screw and tighten to a snug fit.
  - c. Tighten the right mounting screw to a snug fit.
  - d. Make sure each screw is tightened evenly.
3. Review the following notes before continuing to [Programming and verifying on page 147](#).

The ERT Module is programmed based on the meter's drive rate. Take note of the index drive rate shown on the drive dial on the index. The ERT Module is programmed based on the drive rate.

Itron residential meter index drive rates are typically two cubic feet.

## Connecting to a Sprague 175RM meter



1. Remove the index cover mounting screws and the index cover from the Sprague 175RM meter. Discard the index cover and index cover mounting screws.



2. Loosen the index mounting screws half to one turn.
3. Slide the index up and off the mounting screws and remove it from the meter.
4. Set the index aside where it will not be damaged or fill with dirt, rain or snow. You will mount the index in the module later in this procedure.
5. Remove the index mounting screws from the meter. Verify that the index mounting screws are 1/4 inch long and not corroded.

If the screws are the correct length and not corroded, retain for later use. If the original screws are discarded, use the correct replacement screws.

6. Remove the old gasket, gasket residue, and dirt from the meter (if applicable). The meter face must be free of gasket residue and dirt before you install the ERT Module.



7. Separate the ERT Module housing from the cover by pulling the cover straight out from the housing. Set the module cover aside for use later in this installation procedure.



8. Screw the index mounting screws into the index mounting posts loosely (one to two turns). Do not tighten the screws.
9. Review the following notes before continuing to [Programming and verifying on page 147](#).

The ERT Module is programmed based on the meter's drive rate. Take note of the index drive rate shown on the drive dial on the index. The ERT Module is programmed based on the drive rate.

Itron residential meter index drive rates are typically two cubic feet.

### Reassembling the index on Itron/Sprague meters

This procedure assumes you have programmed your module as described in [Programming and verifying on page 147](#). If you are assembling on a Sprague 175RM meter, skip to [Reassembling the index on Sprague 175RM meters on page 38](#).

1. Align the ERT Module so one of its four drive fins (1) lines up with the meter drive dog (2).



**Warning!** Failure to correctly align the meter drive post and ERT Module wriggler can cause binding and lead to poor registration or meter failure. If there is a gap between the ERT Module gasket and the meter, it may be that the wriggler of the ERT Module is *dead-headed* against the meter drive dog as shown in the following illustration. Remove the ERT Module assembly and repeat the alignment procedure. You must engage the meter drive post with the ERT Module wriggler.

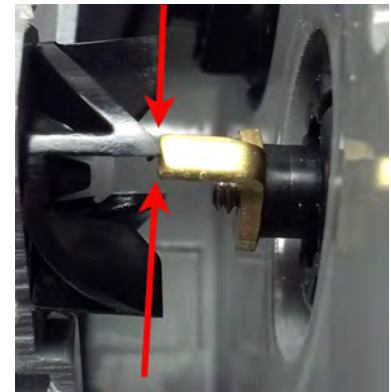

2. Place the ERT Module on the meter.
3. Insert the right module mounting screw and tighten the screw until the gasket is against the meter. Do not completely tighten the mounting screw.



4. Slightly raise the left side of the ERT Module (the module will rotate on the right screw) until the left ERT Module mounting hole is approximately 1/4 inch above the left meter mounting hole.



5. Rotate the ERT Module down until the module mounting hole is approximately 1/4 inch below the meter hole.



6. Rotate the ERT Module up to align the left mounting holes. Raising and lowering the ERT Module on the meter drive post facilitates the proper positioning and engagement of ERT Module wriggler with the meter drive post.



7. Insert the left mounting screw and tighten a few turns. Tighten the right and left ERT Module-to-meter mounting screws in an alternating pattern. Tighten each mounting screw evenly. Torque the mounting screws 15 to 20 inch-pounds.





**Important!** The following conditions ensure proper engagement of the ERT Module to the meter.

- The ERT Module fits flush against the meter body so there are no gaps between the ERT Module gasket and the meter body.
- The ERT Module mounting holes align with the index cover mounting holes on the meter body.
- The meter test dial moves in relation to gas flowing through the meter.

8. Place a new tamper seal in the tamper seal cups surrounding the two mounting screws. Press the new tamper seals into place using an 11/32 inch nut driver or similar blunt tool. ERT Module installation on the Itron meter is complete.
9. Complete any necessary paperwork and properly dispose excess installation materials and scrap from the customer premises.

Next, if you have a flat-faced meter to which you need to attach a brass meter tag, see [Attaching brass meter tags to flat-faced meters on page 40](#).

### Reassembling the index on Sprague 175RM meters

This procedure assumes you have programmed your module as described in [Programming and verifying on page 147](#).

1. Align the index wiggler (1) with the ERT Module drive post (shaft, 2).

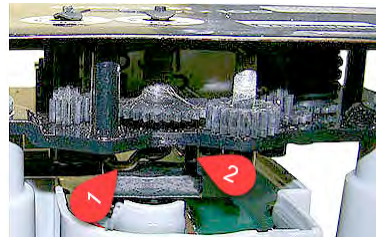

2. Carefully slide the index onto the mounting screws. Verify that the module's drive post makes positive engagement with the index wiggler. Tighten the index mounting screws.



3. Slide the ERT Module cover over the index and housing. Verify that the cover is installed correctly. The label should be clearly visible and easily read.



- Align the module wriggler (1) with the meter's drive dog (2).



**Warning!** Misaligning ERT Module's wriggler with the meter drive post can cause binding and lead to poor registration or meter failure.

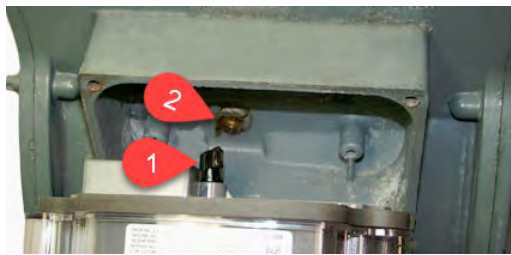

- Use the replacement mounting screws shipped with the ERT Module. Install module-to-meter mounting screws in an alternating pattern.

Tighten the mounting screws in the order numbered and in an alternating diagonal fashion as shown in the illustration. Tighten each mounting screw evenly. Torque the mounting screws 15 to 20 inch-pounds.



- Place a new tamper seal over the two screws in the tamper seal cups. Press the new tamper seals into place using an 11/32 inch nut driver or similar blunt tool.



7. Complete any necessary paperwork and properly dispose excess installation materials and scrap from the customer premises.
8. ERT Module installation on the Sprague 175RM meter is complete.



### Attaching brass meter tags to flat-faced meters

Some older Sprague meters have metal index covers with brass meter tags attached (by screws or rivets) to metal index covers.

Typically, brass meter tags have mounting (screw/rivet) holes on each end of the tag. Secure the brass meter tag using one of the three Itron-approved methods.

- [Method 1: Attach the meter tag to the adapter plate tag mounting hole on page 41](#)
- [Method 2: Attach the meter tag to the ERT Module mounting hole on page 42](#)
- [Method 3: Place the brass meter tag inside the ERT Module assembly on page 42](#)

**Note:** The module depicted in the instructions below may vary slightly in appearance from the ERT Module you are installing.





#### Method 1: Attach the meter tag to the adapter plate tag mounting hole

1. Carefully remove the brass meter tag from the meter index cover. Try not to damage the meter tag mounting holes.
2. Attach the ERT Module assembly to the meter. The Sprague adapter plate has tag mounting holes in the lower left and right corners. Secure the meter tag to one of the holes with a utility-approved and provided security seal.
3. Attach the meter tag to the adapter plate tag mounting hole
4. Attach the meter tag to the meter mounting hole.

If the brass meter tag will be secured to the meter using the meter index cover mounting hole, it must be attached during the installation procedure.



**Caution:** A protruding brass meter tag can present a safety concern, particularly if the tag is damaged with sharp edges protruding from the meter.

### Method 2: Attach the meter tag to the ERT Module mounting hole



1. Carefully remove the brass meter tag from the meter index cover. Try not to damage the meter tag mounting holes.
2. Attach the ERT Module assembly to the meter. The Sprague adapter plate has tag mounting holes in the lower left and right corners. Secure the meter tag to one of the holes with a utility-approved and provided security seal.
3. Attach the meter tag to the ERT Module mounting hole.
4. Attach the meter tag to the meter mounting hole.

If the brass meter tag will be secured to the meter using the meter index cover mounting hole, it must be attached during the installation procedure.



**Caution:** A protruding brass meter tag can present a safety concern, particularly if the tag is damaged with sharp edges protruding from the meter.

### Method 3: Place the brass meter tag inside the ERT Module assembly

1. Carefully remove the brass meter tag from the meter index cover. Try not to damage the meter tag mounting holes.

2. Attach the ERT Module assembly to the meter. The Sprague adapter plate has tag mounting holes in the lower left and right corners. Secure the meter tag to one of the holes with a utility-approved and provided security seal.
3. Remove the ERT Module index cover and place the meter tag inside the ERT Module assembly for optimal meter tag security.



## National (Lancaster)

This section provides instructions to install the ERT Module (including part numbers ERG-5006-006, ERG-5600-006, ERG-7000-006, and ERG-7600-006) on compatible residential National (Lancaster) meters, including:

- 175
- U175 and UL175
- 250

National meter indexes with bow-tie shaped wrigglers cannot be used.

Actaris/Schlumberger/Sprague direct read (odometer) indexes cannot be used.



National (Lancaster) meter indexes are available in different models. Some National meter indexes have index legs to mount the index on the meter or ERT Module. Some indexes have both legs and index mounting holes and some have just mounting holes.



Mounting methods are dependent on the index. Index types require different mounting screws to attach the index to the ERT Module housing.

- Indexes with legs must be mounted to the ERT Module housing mounting posts (1).
- Indexes with mounting holes must be attached to the ERT Module housing's bracket mounting posts (2).

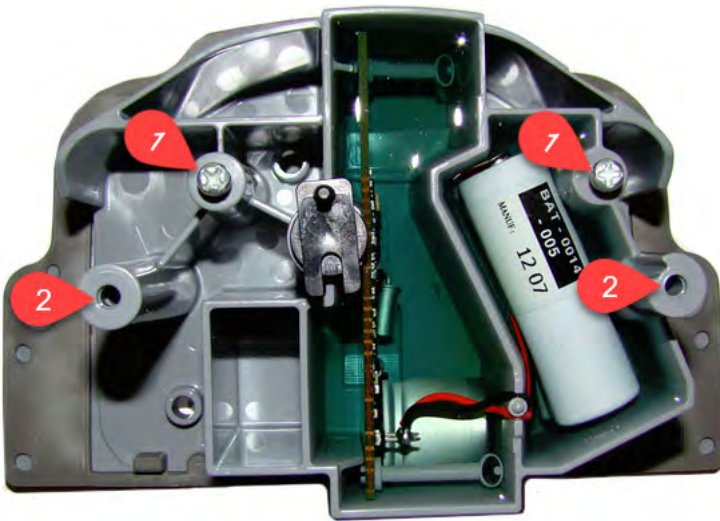

### Connecting instructions

If your index has legs with mounting screw slots, skip steps 9 and 10. If your index has mounting screw holes in the index back plate (no legs), perform steps 9 and 10, and skip steps 11 and 12 (these instructions are reiterated in the steps below).

1. Remove any tamper seals from the index cover screws.
2. Remove and discard the index cover screws and the index cover from the meter. The ERT Module includes new, different-size ERT Module mounting screws.



3. Remove one index mounting screw completely. Hold one hand under the index to catch the screw.
4. While you remove the other mounting screw, pull the index away from the meter to keep the index backplate against the back of the screw. Remove the screw completely after the index is free of the meter.



5. Set the index aside.
6. Discard the index mounting screws.
7. Remove the old gasket, gasket residue, and dirt from the meter (if applicable). The meter face must be free of gasket residue or dirt before you install the ERT Module assembly.
8. Separate the module housing from the cover by pulling the cover straight out from the housing.





- Set the ERT Module cover aside where it will not be damaged or fill with rain, dirt, or snow. You will use the cover later in this installation procedure.



**Caution:** Use only dial-type indexes from National, Actaris, Schlumberger, or Sprague meters with the ERT Module. Indexes with bow-tie shaped wrigglers are not compatible with the ERT Module. You must use a compatible index.

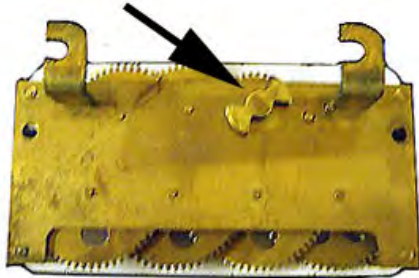

- Review the following notes before continuing to [Programming and verifying on page 147](#).

Take note of the index drive rate shown on a top right dial on the index. The endpoint is programmed based on the drive rate. National/Lancaster meter index drive rates are typically two cubic feet.

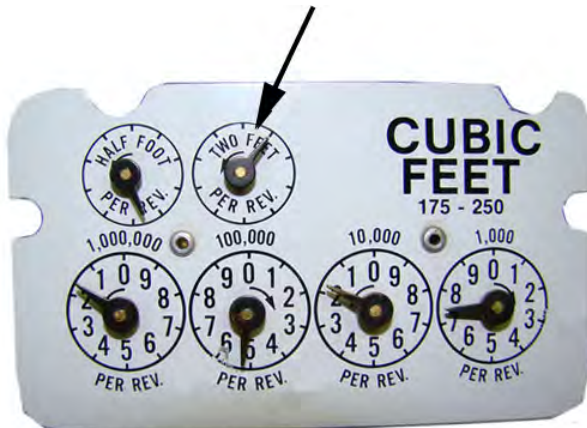

### Reassembling the index on National meters

This procedure assumes you have programmed your module, as described in [Programming and verifying on page 147](#).

- If your index has legs with mounting screw slots, skip to step 3. Otherwise continue to step 2.
- For indexes with mounting screw holes in the index back plate (no legs), use the replacement index mounting screws (SCR-0037-001). Place one screw into the index's right-hand mounting screw hole.

3. Attach the screw to the ERT Module housing's right-index mounting post just enough to hold the screw and the right end of the index in place. Skip to step 5.
4. For indexes with legs (mounting slots), screw one 10-20 x 3/8 inch screw (SCR-0017-001) into the right index mounting post one or two turns. Do not completely tighten the screw.
5. Place the right index mounting screw slot under the screw head. Do not completely tighten the screw.
6. Carefully slide the index drive post into the ERT Module shaft slot. Verify positive engagement of the index wiggler to the ERT Module shaft. The following illustrations show index to shaft placement with positive engagement.



7. Verify that the index drive slot engages with the ERT Module shaft. Failure to mate the ERT Module shaft with the index drive post (or slot) can cause binding and lead to poor registration or meter failure.

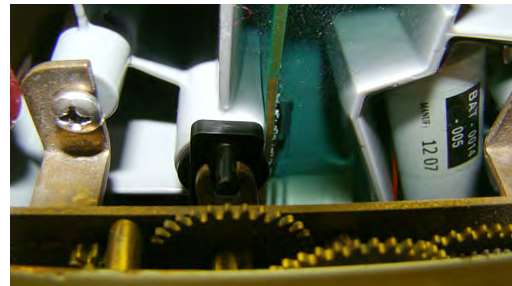
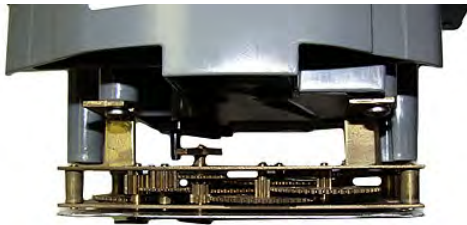

8. Install and tighten the left index mounting screw (for indexes with either mounting screw slots or holes). Tighten the right index mounting screw. Tighten each index mounting screw evenly.

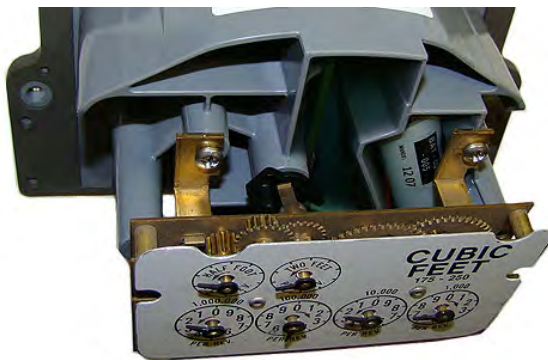

9. Slide indexes with mounting screw slots all the way to the right. Verify that the ERT Module shaft is aligned with the index drive post. Hold the index tightly in place while you secure the index mounting screws.
10. Slide the ERT Module cover over the index and housing. Verify that the cover is installed correctly. The ERT Module label should be clearly visible and easily read.



11. Align the black wiggler (1) so one of its four drive fins lines up with the meter's drive dog (2).



12. Carefully place the ERT Module on the meter.

**Warning!** Failure to correctly align the meter drive post and ERT Module wiggler can cause binding and lead to poor registration or meter failure. If there is a gap between the ERT Module gasket and the meter, it may be that the wiggler of the ERT Module is *dead-headed* against the meter drive dog as shown in the following illustration. If the wiggler and drive post are *dead-headed*, remove the ERT Module assembly and repeat the alignment procedure. You must engage the meter drive dog in the ERT Module wiggler.

13. Insert the right module mounting screw and tighten the screw until the gasket is against the meter. Do not completely tighten the mounting screw.
14. Slightly raise the left side of the ERT Module (the module will rotate on the right screw) until the left ERT Module mounting hole is approximately 1/4 inch above the left meter mounting hole.





15. Rotate the ERT Module down until the ERT Module mounting hole is approximately 1/4 inch below the meter index mounting hole.



16. Rotate the ERT up to align the left mounting holes. Raising and lowering the ERT Module on the meter drive post facilitates the proper positioning and engagement of ERT Module wriggler with the meter drive post.



17. Insert the left mounting screw and tighten a few turns.
18. Tighten the right and left ERT-to-meter mounting screws in an alternating pattern. Torque the mounting screws 15 to 20 inch-pounds.



**Important!** The following conditions ensure proper engagement of the ERT Module to the meter.

- The ERT Module fits flush against the meter body so there are no gaps between the ERT Module gasket and the meter body.
- The ERT Module mounting holes align with the index cover mounting holes on the meter body.
- The meter test dial moves in relation to gas flowing through the meter.

19. Place a new tamper seal in the tamper seal cups surrounding the two mounting screws. Press the new tamper seals into place using an 11/32 inch nut driver or similar blunt tool.



20. Complete any necessary paperwork and properly dispose excess installation materials and scrap from the customer premises.

This completes installation of the ERT Module on the National (Lancaster) meter.

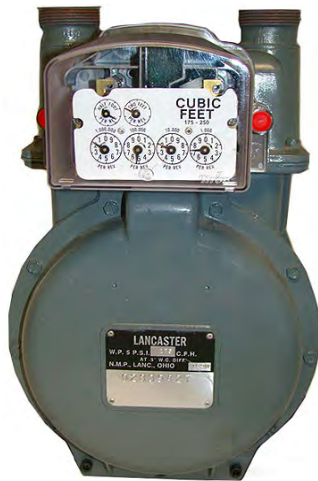

## Romet rotary meter

This section describes installing the ERT Module (including part numbers series ERG-5006-001, ERG-5600-001, ERG-7000-001, and ERG-7600-001 as well as ERG-5006-005, ERG-5600-005, ERG-7000-005, and ERG-7600-005) on the following compatible commercial Romet meters:

- RM Series

**Note:** You must purchase adapter kit from Romet to connect to a residential ERT Module.

## Connecting instructions

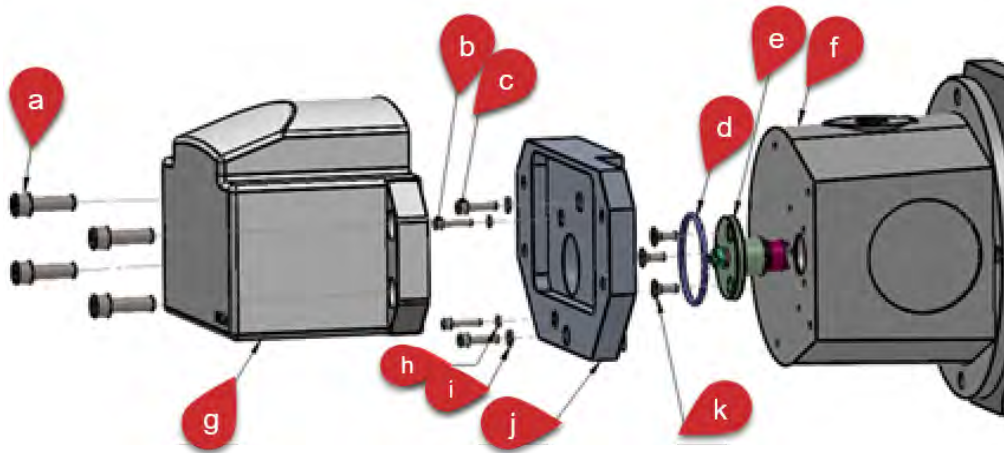

**Note:** (f) points to the Romet STD CTR.

1. Assemble the O-Ring (d) on the meter drive dog.
2. Insert the drive dog (e) into the Romet rotary meter and secure it to the meter using the three flat head screws (k).
3. Mount the adapter plate (j) over the meter drive dog and to the Romet rotary meter using the lock washers (h, i) and the socket head cap screws (b, c).
4. Tighten the adapter plate mounting screws in an alternating pattern.
5. Continue to [Programming and verifying on page 147](#).

### Reassembling the index for the Romet rotary meter

This procedure assumes you have programmed your module, as described in [Programming and verifying on page 147](#).

1. Align the ERT Module wiggler with the meter drive dog.
2. Ensure that the drive dog aligns with the space between the wiggler's teeth.



**Warning!** A gap may be caused by misalignment of the module wiggler and the meter wiggler's drive teeth. Pushing down on the module could damage the module's wiggler or meter drive teeth. To eliminate a gap, remove the module assembly and re-align the module's wiggler with the meter drive dog.

3. Secure the ERT Module to the adapter plate using the four socket head cap screws.
4. Complete the necessary paperwork and verify that all excess materials are removed from the customer's premises.

This completes the installation of the ERT Module.

## Sensus/Rockwell

**Note:** Sensus meters are also known as Invensys, Equimeter, or Rockwell. For these instructions, all meter types are referred to as Sensus meters.

This section provides the information to install the ERT Module on a residential Sensus gas meter. These instructions apply to 11-tooth, 16-tooth, and 18-tooth residential Sensus gas modules. 24- and 30-tooth gears are not compatible with the ERT Module.

- 11-tooth residential Sensus gas meters compatible with part numbers ERG-5006-002, ERG-5600-002, ERG-7000-002, and ERG-7600-002:
  - 250
  - 310
  - Cubix250
  - MR-7 (Cubix250 Metric)
  - R-315
  - R-275
  - R-200
  - R-175
  - RC-230
  - RC-225
  - RT-275
  - RT-230
  - RT-225
  - RT-200
  - S-275
  - S-200
  - S-120
  - S-110
  - T-120
  - T-110
- 16-tooth residential Sensus gas meters compatible with ERG-5600-003, ERG-5006-003, ERG-7000-003, and ERG-7600-003:
  - RCM-230 (RC-230 Metric)
  - MR-8 (R-275 Metric)

- MR-5 (S275 Metric)
- MR-9 (R-315 Metric)
- MR-12 (415 Metric)
- 18-tooth residential Sensus gas meters compatible with ERG-5600-004, ERG-5006-004, ERG-7000-004, and ERG-7600-004:
  - RT-100
  - S-175
  - S-190
  - RT-360
  - 415

**Note:** Older meters may have module-to-meter mounting hole variations that make them incompatible.

Module configuration with the meter is dependent on your system application. See Sensus meter documentation for more information.



**Important!** Modules ordered pre-programmed with security injected and specified as Zero Touch Deployment require that the installer rotate the wiggler five times to activate the ERT Module if installing in a location with little or no gas flow.

## Connecting instructions

**Note:** The module depicted below may vary slightly in appearance from the ERT Module you are installing.

1. Remove the four index cover screws and the index cover from the Sensus meter. Alternate screw removal following the numbered pattern as shown in the illustration.

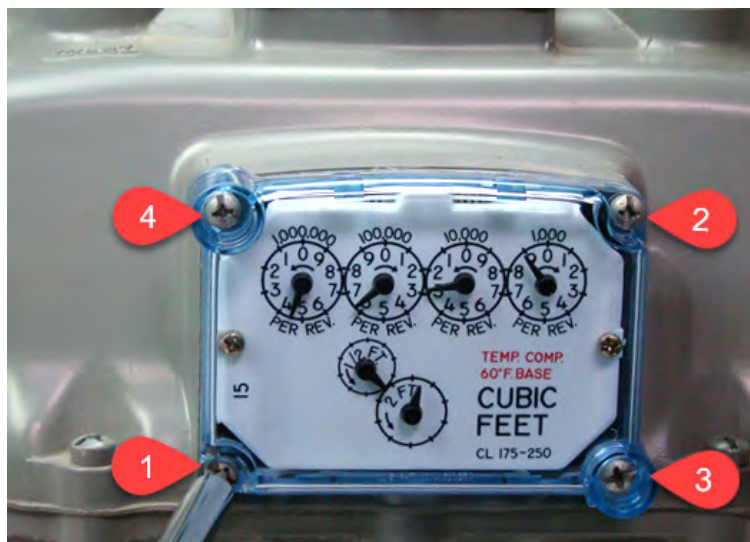

2. Examine the index cover screws. If they are 0.625 (5/8) inch long and not corroded, keep them to attach the ERT Module assembly. If the screws are not the correct length or if the screws are corroded, discard them.
3. Remove one index mounting screw completely. Hold one hand under the index to catch the screw. While removing the other mounting screw, pull the index away from the meter to keep the index backplate against the back of the screw. Remove the screw completely after the index is free of the meter.



4. Set the index aside where it will not be damaged or fill with dirt, rain, or snow. You will mount the index on the ERT Module later in this procedure.
5. Verify that the index mounting screws not corroded. If the screws are the not corroded, retain for later use. If you discard the original screws, use the correct replacement screws. For screw replacement information, see [Direct-mount module variant on page 12](#).
6. Remove the old gasket, gasket residue, and dirt from the meter (if applicable). The meter face must be free of gasket residue or dirt before you install the ERT Module.



7. Separate the ERT Module housing from the clear cover by pulling the cover straight out from the housing. Set the ERT Module cover aside where it will not be damaged or fill with rain, dirt, or snow. You will replace the cover later in this installation procedure.
8. Place the index drive gear (1) in the shaft gear cup (2) of the ERT Module. The example shows an 11-tooth drive gear. Your index may be a 16- or 18-tooth gear. Use the



appropriate module for your specific meter.

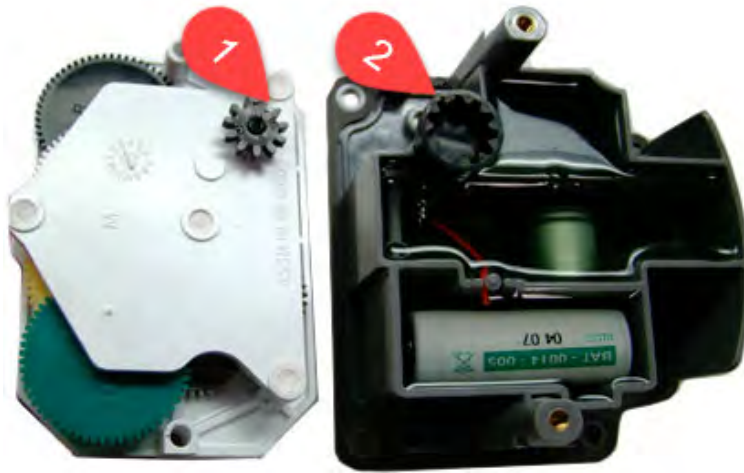

**Warning!** Indexes have varying drive mechanism styles. Failure to align the ERT Module shaft with the index drive post can cause binding and lead to poor registration or meter failure. To verify proper engagement of the index to the ERT Module shaft, spin the wriggler one clockwise rotation, then one-counterclockwise rotation. Do not spin the shaft more than one complete rotation. The shaft should spin freely, with little or no resistance.

9. After the index drive gear is aligned and inserted into the shaft gear cup, the mounting holes will line up.



10. Using the original index mounting screw or a replacement screw (if necessary), place one #6-32 by 5/8-inch screw into the index right mounting screw hole.
11. Attach the screw to the ERT Module housing right-index mounting post just enough to hold the screw and the right end of the index in place.
12. Install and tighten the left index mounting screw.
13. Tighten the right index mounting screw completely. Install and tighten both index mounting screws evenly.



- Slide the ERT Module cover over the index and housing. Verify that the cover is installed correctly. The ERT Module label should be clearly visible and easily read.



- Review the following notes before continuing to [Programming and verifying on page 147](#).

The ERT Module is programmed based on the meter's drive rate. Take note of the index drive rate shown on a lower dial on the index. Sensus meter index drive rates are typically two-cubic feet.



### Reassembling the index on Sensus/Rockwell meters

This procedure assumes you have programmed your module, as described in [Programming and verifying on page 147](#).

- After the ERT Module programming is complete, attach the ERT Module assembly to the Sensus meter.
- Place the ERT Module assembly against the front of the meter at angle.



**Warning!** Failure to correctly align the meter drive gears and module drive gears can cause binding and lead to poor registration or meter failure. If there is a gap between the ERT Module gasket and the meter, it may be that the drive gears of the ERT Module assembly's wiggler are not correctly aligned with the meter drive gears. Remove the ERT Module assembly and repeat the alignment procedure. You must engage the ERT Module wiggler with the meter drive gears.

3. Install and tighten the ERT Module-to-meter mounting screws in an alternating pattern. Use the original mounting screws if they were the correct size and not corroded. If you discarded the original screws, use the correct replacement screws.



**Caution:** As the ERT Module assembly is secured into its final position on the meter, shifting may occur due to existing tolerances within the mounting screw holes. To ensure full module wiggler gear to meter gear engagement, push the ERT Module to the right while tightening the screws in the following pattern.

- a. Align the top right mounting screw hole on the meter with the top right screw hole on the ERT Module.
  - b. Insert the top right cover mounting screw and tighten the screw enough to hold the ERT Module assembly in place. Do not completely tighten the screw.
  - c. Rotate the ERT Module assembly counterclockwise until the remaining three module screw holes line up with the holes in the meter.
4. Install the remaining three mounting screws and tighten them as described here and shown in the illustration. Torque the mounting screws 15 to 20 inch-pounds.
    - a. Insert lower left mounting screw (2) and tighten to snug position.
    - b. Tighten upper right mounting screw (1,3) to snug position.
    - c. Insert upper left mounting screw (4) and tighten to snug position.
    - d. Insert lower right mounting screw (5) and tighten to snug position.
    - e. Tighten each mounting screw evenly.

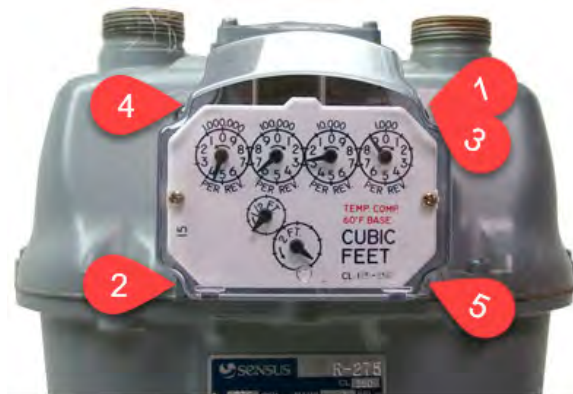

5. Place a new tamper seal over the two screws with tamper seal cups. Press the new tamper seals into place using an 0.34 (11/32) inch nut driver (or similar blunt tool).



6. Complete any necessary paperwork and properly dispose excess installation materials and scrap from the customer premises.

This completes installation of the ERT Module installation on the Sensus meter.



## Commercial meters

This section describes the installation procedures for direct-mounted ERT Modules on commercial gas meters, including:

- [Elster American Installation on page 59](#)
- [Dresser \(GE Oil and Gas\) on page 64](#)
- [Itron/Sprague on page 69](#)
- [Romet rotary meter on page 75](#)
- [Sensus/Rockwell installation on page 76](#)

## Elster American Installation

Commercial modules mount on Elster American meters in various configurations. These instructions assume you are installing metal mounting plates without tamper seal cups and plastic mounting plates with tamper seal cups that represent mounting plate options.

Indexes may be mounted on the commercial ERT Module Elster American meter module without mounting plates. Index covers may (or may not) have tamper seal cups (on the back of the cover) for added security. Index removal assumes the installer removes any tamper seals or wires before continuing with these instructions.

**Note:** It may not be necessary to dismantle your commercial index assembly (index and cover). These instructions do not include index/cover assembly for those applications. Some diaphragm commercial meters do not require an index assembly mounting plate. Indexes can be mounted directly to the module.

Module configuration with the meter is dependent on your system application. See the Elster American meter configuration documentation.

Some meter manufacturers provide mounting kits and installation procedures for their meters. If the Elster American meter to the ERT Module installation instructions are not available, follow the installation procedures in this section.

This section provides instructions to install the commercial ERT Module (including part numbers ERG-5006-007, ERG-5600-007, ERG-7000-007, and ERG-7600-007) on the following compatible Elster American commercial meters:

- AL800 W75AL aluminum case
- AL1000 top mount index
- AL1400 top mount index
- AL2300 top mount index
- AL3000 top mount index
- AL5000 top mount index
- 35B iron case
- 60B iron case
- 80B iron case, must have front reading index
- 250B iron case
- 500B iron case



**Important!** ERT Modules ordered pre-programmed with security injected and specified as Zero Touch Deployment require that the installer rotate the wiggler five times to activate the ERT Module if installing in a location with little or no gas flow.

The following figure shows a ERT Module that is compatible with a commercial Elster American meter.



## Connecting instructions

**Note:** The module depicted below may vary slightly in appearance from the ERT Module you are installing.

1. Remove any tamper seals (or wire seals) from the index cover and mounting plate screws. Set the index and cover assembly aside. You will re-install it later in these instructions.



2. Remove the index cover screws from the meter. Verify that screws are 0.5 inch long and are not corroded. If the screws are the correct length and are not corroded, keep them to re-install the module assembly later in this procedure. If the screws are damaged or not the correct length, discard.
3. Remove any tamper seals from the mounting plate.
4. Remove the mounting plate screws and separate the mounting plate from the meter. Place the mounting plate where it will not be damaged. You may use it later in this installation.



- Review the following notes before continuing to [Programming and verifying on page 147](#).

The ERT Module is programmed based on the meter's drive rate. Take note of the index drive rate shown on a lower dial on the index. Elster American meter index drive rates are either cubic foot, two cubic feet, or 0.05 cubic meters (not shown below).



### Reassembling the index on Elster American meters

This procedure assumes you have programmed your module, as described in [Programming and verifying on page 147](#).

- Tilt the commercial module at an angle and turn the wiggler until the wiggler's notches line up with the meter's drive dog teeth.

Failure to properly align the ERT Module wiggler with the meter drive post can cause binding and lead to poor registration or meter failure.

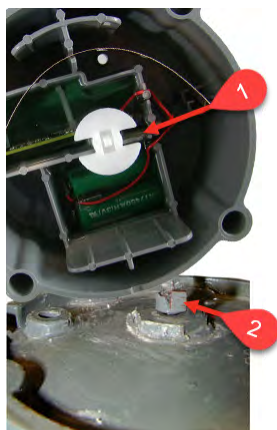



2. Align the ERT Module so the screw holes line up with the meter's top screw holes. Carefully lower the module on the meter with the wriggler notches lining up with the meter's drive dog teeth.



**Warning!** The INLET label on the ERT Module must line up with the INLET label on the meter case.

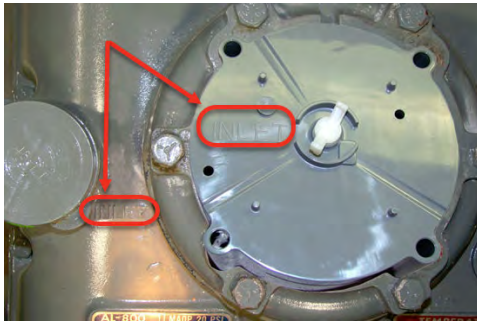

3. Verify that the bottom of the ERT Module and the top of the meter meet. The ERT Module housing should rest on top of the meter without gaps.



**Warning!** Do not press down on the ERT Module if a gap exists between the ERT Module and the meter. A gap may be caused by misalignment of the ERT Module wriggler and meter's drive post. Pushing down on the ERT Module could damage the ERT Module wriggler or meter drive post. To eliminate a gap, slowly turn the ERT Module's drive shaft back and forth until the module aligns with the meter's drive teeth.



4. Place the index cover mounting plate on the commercial ERT Module so the printing "FLOW FRONT AL800 AL1000 AL1400 AL2300 AL5000 TURBINE ROTARY" stamped on the plate is toward the front of the meter. (A gap between the mounting plate and meter at the screw locations is normal.)

**Note:** The module depicted below may vary slightly in appearance from the ERT Module you are installing.





5. Install four mounting screws included with the ERT Module and tighten them in an alternating diagonal sequence.

For metal mounting plates with a flat screw surface, use ERT Module mounting screws with internal tooth washers.

For plastic mounting plates with tamper screw cups, use ERT Module mounting screws (use O-ring AS-568A-011, 5/16 inch ID x 7/16 inch OD for a maximum moisture seal).

6. Turn each screw a quarter to half a turn after it contacts the mounting plate. If you have access to a torque driver, tighten mounting screws to 20-25 inch-pounds.



7. Place new tamper seals over screws (if the mounting plate has tamper seal cups). Press the tamper seals into place with an 11/32 inch nut driver or a similar blunt tool.
8. Place the mounting plate gasket (previously removed) on the index cover mounting plate. Align the gasket and index cover mounting plate screw holes.
9. Place the index and cover assembly on the index mounting plate. (The index must face the direction it faced before removal.) Attach the index/cover assembly on the mounting plate using original 1/2 inch index screws.
  - a. Insert one screw and tighten two turns to hold it in place on the mounting plate.
  - b. Insert the second mounting screw and tighten until secure.
  - c. Completely tighten the first mounting screw.

- d. Tighten each index cover mounting screw.



10. Install new tamper or wire seals. If tamper seals are installed, press into place with an 11/32 inch nut driver or similar blunt tool. Crimp the seal if utility-approved wire seals are installed.

This completes installation of the commercial ERT Module on an Elster American commercial meter.

## Dresser (GE Oil and Gas)

This section provides instructions to install the ERT Module on compatible commercial Dresser meters.

- Part numbers ERG-5006-001, ERG-5600-001, ERG-7000-001, and ERG-7600-001 are compatible with the following Dresser meter types (they must not have a pulser or instrument drive):
  - Series B3, including:
    - 8C-56M CTR
    - 8C-16M TC
  - Series A (LMMA) 1.5M-5M CTR
  - Series A (LMMA) 7M-16M CTR
  - Series A (LMMA)
    - 1.5M-5M TC
  - Series Z
    - 5C/8C15
- Part number series ERG-5006-007, ERG-5600-007, ERG-7000-007, and ERG-7600-007 as well as ERG-5006-008, ERG-5600-008, ERG-7000-008, and ERG-7600-008 are compatible with instrument drive variants (instrument platform with mechanical drive), including:

- B3: CTR or TC
- 8C-11M
- LMMA: CTR or TC
- 1.5M-11M

**Note:** The instrument drive determines whether the ERG-5006-007, ERG-5600-007, ERG-7000-007, or ERG-7600-007 variant (compatible with Elster American commercial meter) or the ERG-5006-008, ERG-5600-008, ERG-7000-008, or ERG-7600-008 variant (compatible with Sensus commercial meter) is required.

Some commercial AMR applications require a Dresser rotary meter with a residential ERT Module. Only Elster American residential ERT Modules are compatible with Dresser-series rotary gas meters. This section provides the instructions to mount an Elster American residential ERT Module on Dresser AMR-ready rotary commercial meters. Installation requires an AMR adapter kit supplied by Dresser.

### Connecting instructions

This installation procedure requires a Dresser rotary gas meter with an instrument drive.

The connecting procedure for Dresser meters are identical to the procedure for Sensus/Rockwell meters. See [Sensus/Rockwell installation on page 76](#).

**Note:** These instructions depict images of a ERT Module compatible with a commercial Elster American meter.

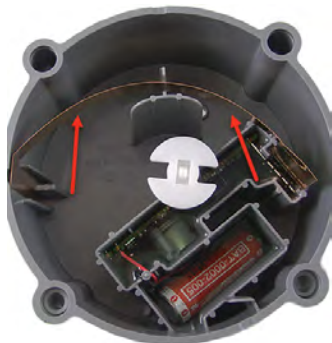

**Warning!** Handle the ERT Module carefully so the metal passive radiator antenna is not damaged.

1. Locate the INSTRUMENT FACE stamp (1) and position the meter with the drive dog (2) centered (as shown).

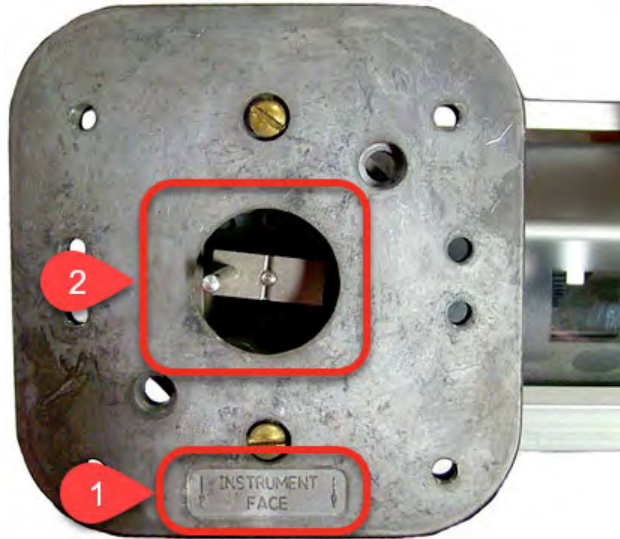

2. Ensure that the ERT Module wriggler (3) and drive-dog shaft (2) are aligned. Failure to properly align the ERT Module wriggler with the meter drive post can cause binding and lead to poor registration or meter failure.



3. Verify that the wriggler and drive-dog shaft are engaged by turning the commercial ERT Module wriggler. When properly engaged, you will feel resistance.
4. Place the customer-supplied index mounting plate on the ERT Module and install the four mounting screws. Do not disturb the shaft alignment.



5. Install the four ERT Module mounting screws. Tighten mounting screws in an alternating, diagonal pattern. Tighten each ERT Module mounting screw evenly.

1. Turn each screw 1/4 to 1/2 turn after it contacts the cover.
  2. Torque to 20 to 25 inch-pounds.
6. Insert new utility-approved wire seals and crimp (if required).

**Note:** To mount an index and index cover on a rotary meter without an accessory odometer unit, remove the domed cover.

7. Review the following notes before continuing to [Programming and verifying on page 147](#).  
The ERT Module is programmed based on the meter's drive rate. See [Table 2](#) for details.

**Table 2** Dresser meter drive rates by index style and meter size

Index style	8C-11M	16M	16M-56M	1.5-11M	16M-102M
B3 CTR index	10		100		
B3 TC index (Meter built 1/1999 and beyond)	10	100			
B3 TC index (Meter built prior to 1/1999)	50	500			
LMMA CTR index				10	100
LMMA TC or Series 3 CTR/TC index		100		10	





**Elster American commercial ERT Module mounted on a Dresser Meter with an instrument drive**



**Sensus commercial ERT Module mounted on a Dresser meter with an instrument drive**

### Reassembling the Dresser index

1. Align the module wiggler with the opening between the tabs of the adapter's drive dog. The ERT Module must be mounted on the adapter plate in an upright position.
2. One by one, insert the module mounting screw's and tighten enough to hold the module (about two turns). Do not completely tighten the screw.
3. Tighten the mounting screws in an alternating, diagonal pattern until snug. Tighten all mounting screws evenly.



**Warning!** A gap may be caused by misalignment of the ERT Module wiggler and adapter's drive teeth. Pushing down on the ERT Module could damage the ERT Module wiggler or adapter's drive teeth. To eliminate a gap, remove the ERT Module assembly and re-align the ERT wiggler with the adapter's drive teeth.

4. Review the following notes before continuing to [Programming and verifying on page 147](#). For 5C15 and 8C15 rotary meters, program as four-dial, two cubic foot index. For all other residential ERT Module to Dresser installations, see [Table 3](#).

**Table 3** Dresser meter drive rates by index style and meter size

Index style	8C-11M	16M	16M-56M	1.5-11M	16M-102M
B3 CTR index	10		100		
B3 TC index (Meter built January 1999 and later)	10	100			
B3 TC index (Meter built prior to January 1999)	50	500			



**Table 3** Dresser meter drive rates by index style and meter size (continued)

Index style	8C-11M	16M	16M-56M	1.5-11M	16M-102M
LMMA CTR index				10	100
LMMA TC or Series 3 CTR/TC index		100		10	

## Itron/Sprague

Itron meters are also known as Actaris, Schlumberger, or Sprague meters. For these instructions, all meters will be referred to as Itron meters.

This section describes installing the ERT Module (part numbers including ERG-5006-007, ERG-5600-007, ERG-7000-007, and ERG-7600-007) on the following compatible commercial Itron/Sprague meters:

- 675A
  - Top-mount index
  - Compatible with
- 800A
  - Top-mount index
- 1000A
  - Top-mount index

### Connecting instructions

1. Place a slotted screwdriver over one of the red security seal covering the index cover mounting screws.
2. Push on the handle-end of the screwdriver to drive the slotted end into the security seal.
3. Pry the broken security seal out of the index screw mounting cup. Be careful not to damage the index cover. Remove the second security seal.

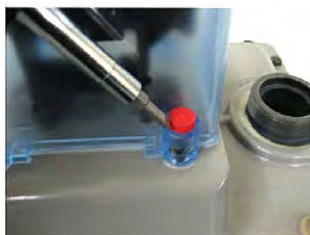

4. Remove the index cover mounting screws with the slotted screwdriver.
5. Carefully remove the index cover and inspect the cover for wear or damage to the RTV (silicone) or cork gasket. The index cover has either a room temperature vulcanizing



(RTV) or cork gasket.



**Caution:** If the RTV silicone gasket is damaged during removal or shows signs of degradation, you must replace it with a new index cover from Itron.

6. Set the index cover aside.
7. Remove the two screws holding the index bracket to the meter.



8. To remove a dial index, loosen the two screws holding the index to the index bracket in an alternating pattern:
  - a. Loosen the right index mounting screw two turns.
  - b. Loosen the left index mounting screw two turns.
  - c. Loosen the right and left index mounting screws until you can slide the index to the left and away from the index mounting screws and bracket.



9. To remove an odometer index, remove the two screws holding the index to the index bracket. Temporarily store the index and index mounting screws in a safe location.



10. Review the following notes before continuing to [Programming and verifying on page 147](#).  
The ERT Module is programmed based on the meter's drive rate. Take note of the index drive rate shown on the drive dial on the index. The ERT Module is programmed based on the drive rate.

Itron residential meter index drive rates are typically two cubic feet.

This completes installation of the commercial ERT Module on the Itron meter.

### Reassembling the index on Itron/Sprague meters

This procedure assumes you have programmed your module, as described in [Programming and verifying on page 147](#).

1. Install the dial index on the index bracket.
  - a. If the original dial index mounting screws cannot be reused, remove them from the index mounting bracket and recycle or discard.
  - b. Insert the dial index mounting screws (part number 010040) in the index mounting bracket. Tighten the index mounting screws just enough to secure them in the index mounting bracket.

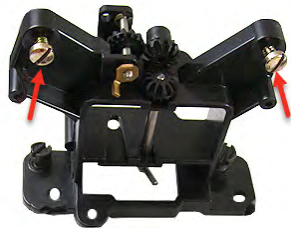

- c. Slide the index mounting legs (1) all the way to the right over the index screws. The mounting bracket drive dog must engage with the index wiggler (2).



**Warning!** Failure to properly engage the mounting bracket drive dog and index wiggler may cause binding and meter failure.



- d. Tighten the index mounting screws in an alternating pattern.



**Warning!** Verify that the index is correctly positioned all the way to the right on the index mounting screws before you tighten the index mounting screws. Failure to properly mount the



index on the index mounting screws may cause binding and meter failure.

- e. Torque the index mounting screws to 3 to 6 inch-pounds.
2. Install an odometer index on the index mounting bracket.
    - a. If the original odometer index mounting screws cannot be reused, recycle or discard them. Use new odometer index mounting screws (part number 090071).
    - b. Align the mounting bracket drive dog with the index wiggler.



**Warning!** Failure to properly engage the mounting bracket drive dog and index wiggler may cause binding and meter failure.

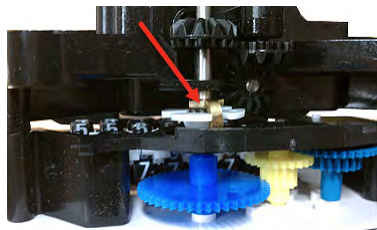

- c. Insert the odometer index mounting screws through the index mounting hole and into the mounting bracket.



- d. Tighten the index mounting screws in an alternating pattern. Torque the index mounting screws to three to six inch-pounds.

**Note:** You must program the commercial module before installation on the Itron commercial meter. For programming information, see [Programming and verifying on page 147](#).

- e. Turn the commercial ERT Module over and place the four mounting screw bushings into the screw holes on the module.



**Warning!** Handle the ERT Module carefully so the passive radiator antenna is not damaged.



- f. Push the screw bushings all the way into the mounting screw holes to secure the screw bushings in the mounting screw hole and prevent them from falling out when the module is turned to install it on the meter.
- g. Turn the module on its side and align the module's wiggler with the meter's drive dog.



**Warning!** Failure to properly align the ERT Module wiggler with the meter drive post can cause binding and lead to poor registration or meter failure.

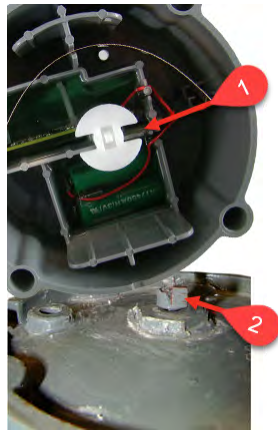

- h. Align the INLET lettering on the commercial module with the INLET lettering on the meter.

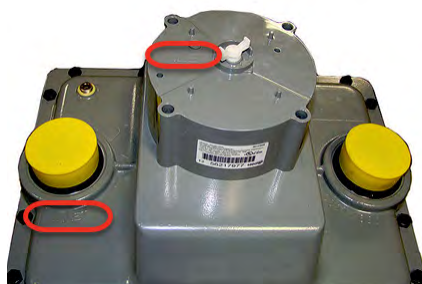

- i. Slowly lower the module onto the Itron commercial meter. Carefully align the meter drive dog and commercial ERT Module wiggler. The module housing should rest on the top of the meter without gaps.



**Warning!** Do not press down on the module if a gap exists between the module and the meter. A gap may be caused by misalignment of the ERT Module wriggler and meter wriggler's drive teeth. Pushing down on the ERT Module could damage the ERT Module wriggler or meter drive teeth. To eliminate a gap, remove the ERT Module and repeat steps 2g and 2h.



- j. Align the back outer index bracket screw holes with the adapter plate mounting holes.



- k. Secure the index assembly to the adapter plate with the two 1/4-20 x 0.375 Fillister-head screws. Torque the index bracket mounting screws three to six inch-pounds.

**Note:** After assembly, the index will be centered on the adapter plate.

- l. Place the extension driver on the commercial module wriggler. Apply a little pressure to ensure that the extension driver seats securely on the commercial module wriggler.



Place the Itron adapter plate on the commercial ERT Module with the two small screw holes in the adapter plate to the back of the meter. The front of the adapter plate must align with the front of the meter (1).

**Note:** The illustration shows the adapter plate without the index mounting bracket assembly or the extension driver to illustrate the location of the small screw holes. Install the index mounting bracket assembly before you place the adapter plate on the commercial module.

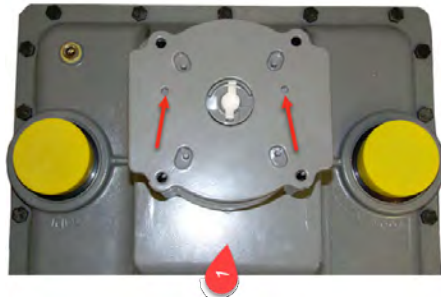

- m. Carefully place the adapter plate index assembly on the commercial module and extension driver assembly. The extension driver (1) must align with the index drive dog (2).



- n. Place the index cover over the index with the clear side covering the index dials for easy reading. Align the holes in the index cover with the adapter plate mounting holes.
- o. Secure with the four mounting screws from the adapter kit. Tighten the mounting screws in a diagonal alternating pattern. Tighten each index mounting screw evenly. If you have access to a torque-driver, tighten mounting screws 20 to 25 inch pounds
- p. Insert tamper seals in the tamper seal cups on the index cover and press into place with an 11/32 nut driver or similar blunt tool.

## Romet rotary meter

This section describes installing the ERT Module (including part numbers series ERG-5006-001, ERG-5600-001, ERG-7000-001, and ERG-7600-001 as well as ERG-5006-005, ERG-5600-005, ERG-7000-005, and ERG-7600-005) on the following compatible commercial Romet meters:

- RM Series instrument drive (the instrument drive allows you to install a commercial ERT Module)

### Connecting instructions

1. Mount the adapter plate over the meter drive dog and to the Romet rotary meter using the lock washers and the socket head cap screws.
2. Tighten the adapter plate mounting screws in an alternating pattern.
3. Continue to [Programming and verifying on page 147](#).

### Reassembling the index on Romet rotary meters

This procedure assumes you have programmed your module, as described in [Programming and verifying on page 147](#).

1. Align the ERT Module wriggler with the meter drive dog.
2. Verify that the drive dog aligns with the space between the wriggler's teeth.



**Warning!** A gap may be caused by misalignment of the module wriggler and the meter wriggler's drive teeth. Pushing down on the module could damage the module's wriggler or meter drive teeth. To eliminate a gap, remove the module assembly and re-align the module's wriggler with the meter drive dog.

3. Secure the ERT Module to the adapter plate using the four mounting screws.
4. Complete the necessary paperwork and verify that all excess materials are removed from the customer's premises.

Installation of the ERT Module on the Romet meter is complete.

## Sensus/Rockwell installation

Sensus meters are also known as Invensys or Rockwell meters. For these instructions, all meter types are referred to as Sensus meters.

Sensus diaphragm commercial meters do not require an index assembly mounting plate. Indexes can be mounted directly to the module. Commercial gas modules can be mounted on Sensus commercial meters in various configurations. These instructions show the index assembly mounted without a mounting plate.

This section provides instructions to install the commercial ERT Module (including part numbers ERG-5006-008, ERG-5600-008, ERG-7000-008, and ERG-7600-008) on the following compatible Elster American commercial meters:

- Compatible with vertical index and aluminum box direct reading (VDR) index
  - 750
  - 1000



- 1600
- 3000
- 10000

**Note:** For VDR index installations, you need two Itron mounting screws (part number SCR-0062-001).

- Compatible with only aluminum box direct-reading (VDR) index
  - 5000

**Note:** For VDR index installations, you need two Itron mounting screws (part number SCR-0062-001).

- Compatible with only vertical index:
  - EMCO #4-1/2
  - EMCO #2-1/2
  - EMCO #3
  - EMCO #4
  - EMCO #5
  - 750
  - 1000
  - 1600
  - 3000
  - 10000

### Connecting instructions

This procedure describes typical installation for the ERT Module with the commercial Sensus/Rockwell gas meter. If installing with a VDR index, see [Connecting with a VDR index on page 79](#).

**Note:** The module depicted below may vary slightly in appearance from the ERT Module you are installing.

1. Remove any tamper seals (or wire seals) from the index cover and remove the index cover mounting screws.

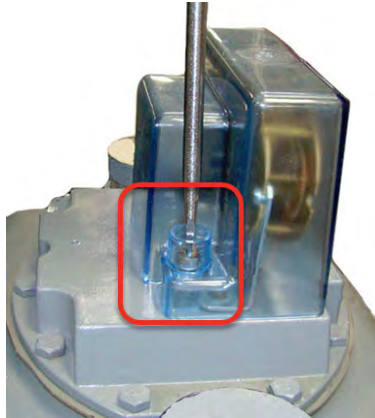

2. Remove the index screws from the meter. Set the index cover aside where it will not be damaged or fill with dirt, rain or snow.

**Note:** Properly dispose all unused screws, old index covers, gaskets, tamper seals, and other leftover materials. Do not leave materials on customer premises.



3. Review the following notes before continuing to [Programming and verifying on page 147](#).  
The ERT Module is programmed based on the meter's drive rate. Take note of the index drive rate shown on a lower dial on the index. Sensus meter index drive rates are typically two-cubic feet.



## Connecting with a VDR index

Installing the commercial Sensus on a Rockwell commercial meter with an aluminum box direct reading (VDR) index requires two Itron mounting screws (part number SCR-0062-001). The mounting screws must be purchased separately.

1. Remove tamper seals and screws from the top of the aluminum box direct reading index. Set the cover and screws aside. You will use them later in the installation.
2. Remove the screws holding the aluminum box to the meter.

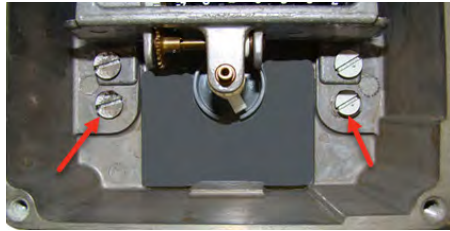

3. Carefully remove the aluminum box and set it aside. You will use it later in this installation.
4. Using a side-cutter, remove the two rear housing pins from the Sensus commercial ERT Module.



Removing the rear housing pins may make the ERT Module incompatible with other commercial meters.

5. Review the following notes before continuing to [Programming and verifying on page 147](#).

The ERT Module is programmed based on the meter's drive rate. Take note of the index drive rate shown on a lower dial on the index. Sensus meter index drive rates are typically two-cubic feet.

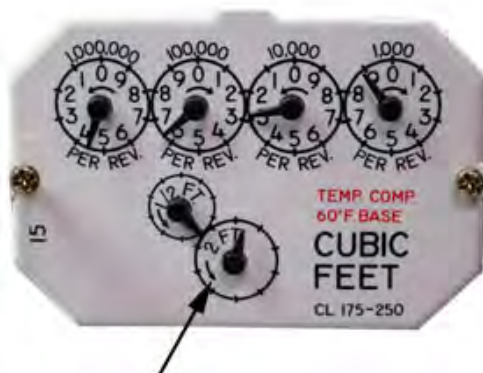

## Reassembling the index on Sensus/Rockwell meters

1. Tilt the commercial ERT Module at an angle and turn the wiggler until the drive notches line up with the meter wiggler's drive teeth.



**Warning!** Failure to properly align the ERT Module wiggler with the meter drive post can cause binding and lead to poor registration or meter failure.

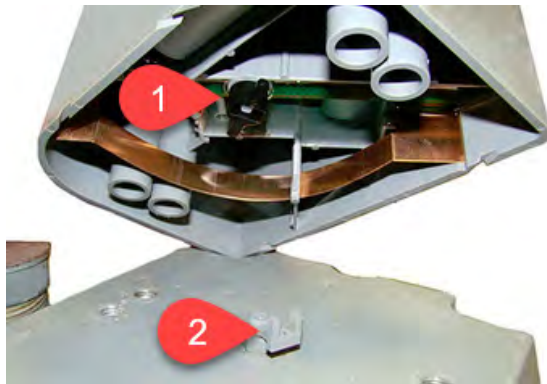

2. Align the ERT Module so the screw holes line up with the meter's top screw holes. Carefully lower the ERT Module on the meter so the wiggler's bars line up with the meter drive dog. Itron recommends installation with one bar inserted into the meter drive dog's u-shaped gear.



**Important!** The INLET label on the commercial ERT Module must line up with the INLET label on the Sensus meter case.

3. Verify that the bottom of the ERT Module and the top of the meter meet. The ERT Module housing should rest on top of the meter without gaps.



Do not press down on the commercial ERT Module if a gap exists between the ERT Module and the meter. A gap may be caused by misalignment of the ERT Module wiggler and meter's drive teeth. Pushing down on the ERT Module could damage the module's wiggler or meter drive teeth. To eliminate a gap, slowly turn the commercial ERT Module's shaft back and forth until the ERT Module wiggler aligns with the meter's drive teeth.



4. Align the ERT Module shaft and mounting holes:
  - *If installed without a VDR index:* with the index mounting holes. Verify the index drive dog intersects with the ERT Module's wiggler.

- *If installed with a VDR index:* with the index drive wriggler.

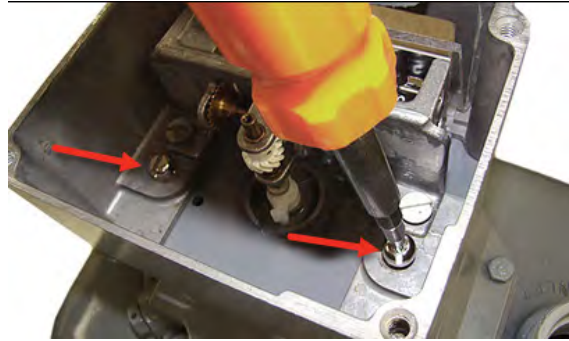

5. Attach the ERT Module to the meter using two SCR-0062-001 Itron mounting screws.
6. Verify the index drive dog intersects with the ERT Module's mounting screws (SCR-0062-003). Turn each screw a quarter to half a turn after it contacts the index assembly.



7. Install the index cover.

For index covers with flat-surface screw holes, use screws (SCR-0062-002), flat washers (WSH-0020-005), and cork washers (WSH-0032-001).

For index covers with tamper seal cups, use screws (AS-568A-011, 5/16 inch ID by 7/16 inch OD), O-rings, and tamper seals.

- Place new tamper seals over screws (if mounting plate has tamper seal cups) and press into place with an 11/32 inch nut driver or similar blunt tool.
- If your mounting assembly requires a utility-approved wire seal, pass wires through holes in the screw heads and crimp the approved wire seal.

This completes installation of the commercial ERT Module on the Sensus commercial diaphragm meter.

This completes installation of the commercial ERT Module.

# 4 Remote-mount installation

This chapter describes the required procedures for installing and mounting the ERT Module.

This chapter describes installation procedures for the following gas meters:

- [Diaphragm meter on page 82](#)
- [Dresser \(GE Oil and Gas\) on page 90](#)
- [Eagle Research on page 104](#)
- [Elster American on page 114](#)
- [Galvanic Gas Micro on page 120](#)
- [Honeywell Instrument on page 120](#)
- [Itron Meter on page 133](#)
- [National meter on page 133](#)
- [Romet meter on page 133](#)
- [Sensus meter on page 144](#)

Depending on your configuration and gas meter, the ERT Module may be mounted to a pole or wall. For these installations, see [Mounting a remote-mount module on page 156](#). If your mounting method is custom to your gas meter, see the instructions for that gas meter.

## Diaphragm meter

Installing the ERT Module to a Diaphragm meter installation involves the following tasks:

1. Wiring the ERT Module to the diaphragm meter.
2. Programming the module.
3. Mounting the ERT Module. Mounting options include:
  - Wall mount on a sheet metal surface
  - Pipe mount

This section provides instructions to install the ERT Module (including part numbers ERG-5006-501, ERG-5600-501, ERG-7000-501, and ERG-7600-501) on compatible Elster American meters. Compatible meters include:

- Elster American 10 Metric (10B)
  - Originally manufactured by Metric Metal Works.
- Itron 1A
  - Flat-face meter where meter body and 1A adapter plate have interference fit issue causing direct mount solution to be non-compatible
- Itron 305
  - #2 flat-face meter
- Itron 400
  - #3 flat-face meter
- Itron 675, 1000
  - Front-mount index
  - The ERT Module requires a thicker gasket for magnet hub to clear the index box. See [Diaphragm meter on page 14](#).

## Wiring instructions



**Caution:** The ERT Module encoder must be installed at temperatures between 40° and 95° F to ensure proper adhesion.

1. Remove the diaphragm meter index cover and index. Use care to hold the index cover and index while loosening the screws to protect them from damage if they are dropped.
  - a. Remove the index cover screws in an alternating pattern. Hold the index cover while the screws are removed to protect it from damage due to being dropped.
  - b. Remove the index cover and set aside.
  - c. Remove the screws holding the index to the meter. Hold the index to protect it from damage due to being dropped.
  - d. Set the index aside.



2. Remove the old gasket and any gasket residue from the meter and index cover.





3. Remove the magnet hub from the encoder installation kit (Itron part number CFG-0081-001). Verify that there is only one magnet in the hub.

**Note:** If there is no magnet or if there are two magnets in the magnet hub, discard the hub. Encoder installation requires a magnet hub with one magnet.



4. Briefly place the magnet side of the magnet hub into the curved indentation in the encoder as shown in the illustration.

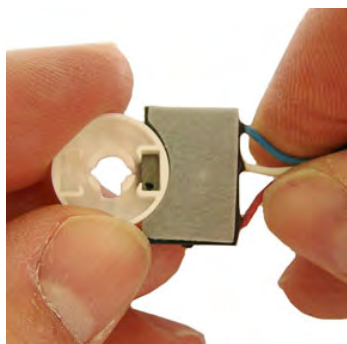

5. Remove the magnet hub from the encoder and set it at least one inch away from the encoder.
6. Use a module programming device to read the ERT Module. If this reading is higher than the reading taken after the index was removed, the remote is counting and working properly.

**Note:** If the reading is not higher than the previous reading, the ERT Module is not working properly. Repeat steps 5 and 6. If the module count is not incrementing, replace the ERT Module and perform steps 5 and 6.

7. Align the large notch in the magnet hub spacer with the needle of the index meter drive rate dial (1 or 2 foot for residential diaphragm meters; 5, 10, or 100 foot for commercial diaphragm meters).
8. Press the magnet hub spacer down over the dial needle as far as possible. The tip on the bottom of the spacer may touch the index face. Turn the dial in the direction noted on the index after the hub is in place to verify the index dial functions with a smooth, easy rotation.



9. Align the pointer (1) on the top of the magnet hub and the notch (2) in the side of the magnet hub with the needle (3) of the meter drive rate dial.

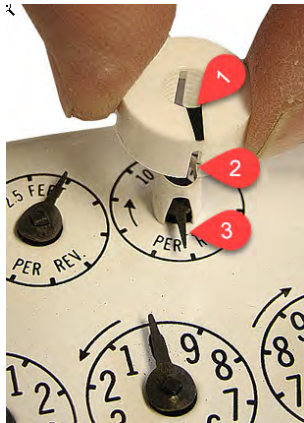

10. Press the magnet hub down over the hub spacer as far as possible. The bottom of the hub spacer may touch the index face. Turn the dial after magnet hub installation to verify that the index dial functions with a smooth, easy rotation.



11. If the dial needle tip sticks out past the edge of the magnet hub, cut off the end of the dial needle as close as possible to the magnet hub with sharp, side-cutting pliers.



12. Remove the acetone stick applicator from the remote encoder installation kit (Itron part number CFG-0081-001). Select a location on the index face next to the magnet hub for the encoder installation. After installation, the encoder cable must not interfere with the index dials.

**Note:** If a TEMP COMP sticker is attached to the index where the encoder cable will mount, remove it before cleaning with the acetone stick. If the sticker (or replacement sticker) must be put back on the register face, place it in a new location on the index face after the encoder is attached.



13. Tilt the acetone stick vertically with the applicator foam end down. Squeeze the acetone stick on the black dot until the packet inside the pen breaks. Continue to hold the pen in a vertical position until the acetone wicks into the foam applicator end. Apply a thorough coat of acetone to the index where the encoder will be installed. Do not touch the area where the acetone was applied before the encoder is installed.
14. Slide the thin end of the encoder spacing tool down over the magnet hub.

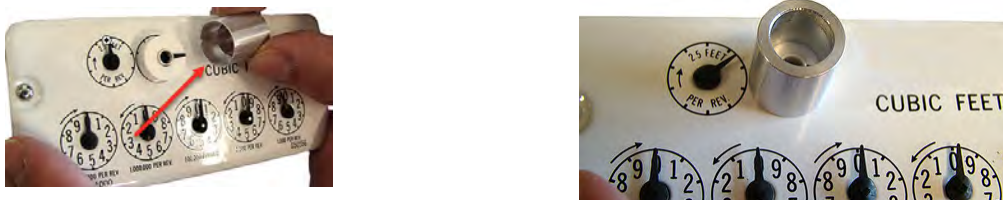

15. Peel the protective plastic away from the adhesive side of the encoder.

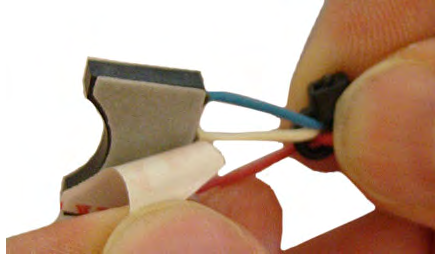

**Important!** You must do the next two steps exactly as described or the ERT Module will not work properly.

16. Press the curved side of the encoder firmly against the side of the encoder spacing tool as shown below, with the adhesive side down. Slide the encoder down along the side of the encoder spacing tool until it touches the surface of the index (as shown below). Using moderate pressure, hold the encoder firmly against the index, without moving, for 15 seconds to permanently apply the encoder.



17. Remove the encoder spacing tool and lay the index on a flat, horizontal surface to reduce strain on the encoder cable.



18. Program the index reading (with the encoder mounted) into the ERT Module. Read the ERT Module and verify that the reading matches the read programmed into the ERT Module. Make sure the consumption increment and number of dials to match the dial you mounted to in step 7.
19. Use the correct replacement gasket for your meter's index. Remove the gasket center and index cover-hole plugs from the new gasket. Insert the index and encoder assembly through the gasket center with the gasket's adhesive-backed side facing the meter.



20. Align the index wiggler with the meter's drive dog. Install the index on the meter using the index mounting screws. Tighten one index screw two turns. Install and tighten the remaining index screw. Tighten the first index mounting screw completely (alternating fashion).

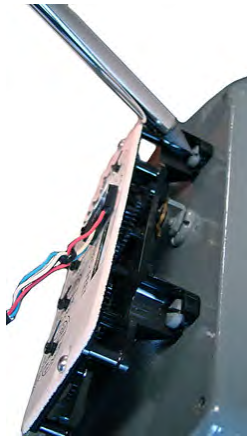

21. Install a strain-relief cable tie about 1.25 inch from the encoder cable's stripped end. The cable tie must be inside the index cover after the cover is installed on the meter. Remove any excess cable tie with a side-cutting pliers and dispose the excess cable tie.

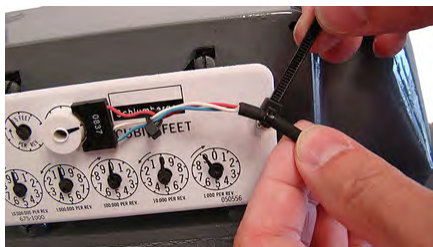

22. Remove the protective backing on the replacement gasket to expose the adhesive side of the gasket. Align the gasket (1), encoder cable (2), and cable tie (for strain-relief) (3) on the meter as shown.



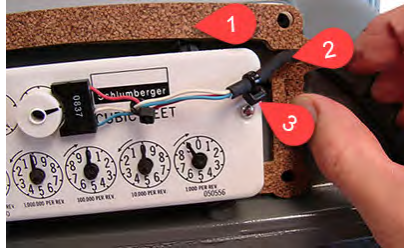

**Caution:** Route the encoder cable inside the index cover to provide strain relief (minimize pulling or twisting on the encoder). Verify that the strain-relief cable tie on the encoder cable is inside the index cover when the cover is installed on the meter. The gasket must align with the index cover screw holes and adhere to the meter face to ensure a proper seal after the index cover is installed.

23. Install the four index cover screws and tighten just enough to hold the screws in place.



24. Verify that the encoder cable is in the correct position in the cable slot of the gasket. Fully tighten the screws in an alternating pattern. Install utility-approved security seals and wires as required.



25. Review the following notes before continuing to [Programming and verifying on page 147](#).

- Residential modules

The ERT Module is programmed based on the meter's drive rate. Take note of the index drive rate shown on a lower dial on the index. Elster American meter index drive rates are either one cubic foot, two cubic feet or 0.05 cubic meters (not shown below).



- Commercial modules

Take note of the index drive rate shown on the index. The ERT Module is programmed based on the drive rate. Elster American commercial meter index drive rates may be 5-, 10- or 100 cubic feet. The index shown has a 10 cubic foot drive rate.

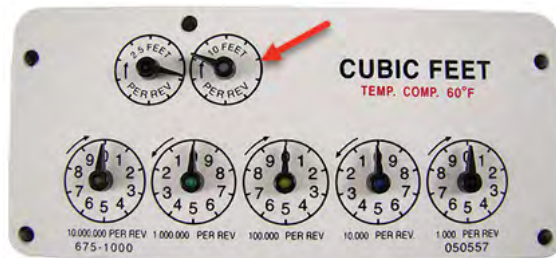

## Dresser (GE Oil and Gas)

Installing the ERT Module to a GE Dresser meter involves the following tasks:

1. Programming the meter to work with the ERT Module.
  - Programming may require a computer and communication cable.
2. Wiring the GE-supplied cable to the ERT Module or wiring the ERT Module to the GE device.
3. If your installation uses a GE supplied cable, connect the cable to the meter. If your installation requires wiring directly to the GE device, continue to step 4.
4. Programming the ERT Module.
5. Mounting the ERT Module. Mounting options include:
  - Wall mount on a sheet metal surface



- Pipe mount
- Custom GE Dresser mounting

ERT Module configuration with the meter is dependent on your system application. See the GE Dresser meter product documentation for configuration information.

This section provides instructions to install the ERT Module on compatible GE Dresser meters. Compatible meters include:

- B3 Series pulse output meter
  - Rotary meters equipped with WeighandWire solid-state pulsers. Meter must have factory-installed pulser with connector output. Purchase correct cable interface from GE Dresser. Pulser must be version 17 or later.
  - Compatible with ERG-5006-503, ERG-5600-503, ERG-7600-503, and ERG-7000-503
- D800/D1000
  - Pulse width must be set to greater than 100 ms. Firmware version must be 1.71 or later.
  - Compatible with part number series ERG-5006-503, ERG-5600-503, ERG-7600-503, and ERG-7000-503 as well as ERG-5006-505, ERG-5600-505, ERG-7000-505, and ERG-7600-505
- Electronic Temperature Compensator (ETC)
  - Pulse width must be set greater than 100ms. Firmware version 1.71 or earlier.
  - Compatible with part number series ERG-5006-503, ERG-5600-503, ERG-7600-503, and ERG-7000-503 as well as ERG-5006-505, ERG-5600-505, ERG-7000-505, and ERG-7600-505
- Integral Micro Corrector IMC/W2
  - Electronic volume corrector for Series A (LMMA) and Series B (rotary meters). Must be meter firmware version 1.94 or earlier. Pulse width must be set for 125ms.
  - Compatible with part numbers ERG-5006-505, ERG-5600-505, ERG-7000-505, and ERG-7600-505
- Integral Micro Corrector MC2
  - Electronic volume corrector for Series A (LMMA) and Series B (rotary meters). Must be meter firmware version 1.94 or earlier. Pulse width must be set for 125ms.
  - Compatible with part numbers ERG-5006-505, ERG-5600-505, ERG-7000-505, and ERG-7600-505
- LMMA pulse output meter

- Rotary meters equipped with WeighandWire solid-state pulsers. Meter must have factory-installed pulser with connector output. Purchase correct cable interface from GE Dresser. Pulser must be version 17 or later.
- Compatible with ERG-5006-503, ERG-5600-503, ERG-7600-503, and ERG-7000-503
- Model 10C25 Series K meter
  - Compatible with part number series ERG-5006-503, ERG-5600-503, ERG-7600-503, and ERG-7000-503 as well as ERG-5006-505, ERG-5600-505, ERG-7000-505, and ERG-7600-505
- Series 3 ES3 meter
  - Pulse width must be set greater than 100ms. Firmware version 1.71 or earlier.
  - Compatible with part number series ERG-5006-503, ERG-5600-503, ERG-7600-503, and ERG-7000-503 as well as ERG-5006-505, ERG-5600-505, ERG-7000-505, and ERG-7600-505

## Programming

Dresser MeterWare software is used to configure and verify the ERT Module's index settings.



**Important!** This information is subject to change without notice. Refer to the GE MeterWare product documentation to verify the most current information about programming and configuring the corrector for use with the ERT Module.

1. Open the GE Dresser MeterWare software to change the ERT Module settings.
2. Select the **LiveData** tab.
3. Confirm the firmware version and current index settings.
4. If you change a variable, click **Update Values** to complete the change.
5. Select the Configuration tab to view the volume configuration or confirm the volume configuration and pulse settings. Use the drop-down lists to change the variable's setting.

**Note:** You must click **OK** to complete any setting changes.

### Testing IMC or W2 communication with Dresser user terminal (UT) communication software

1. Connect the IMC/W2 to the PC using the serial cable.
2. Using the GE Dresser User Terminal (UT) communications software, connect to the IMC/W2.
3. Read the uncorrected or corrected count number on the ERT Module with the Itron endpoint reading device. Compare the IMC/W2 uncorrected or corrected amounts to

those from the ERT Module.

4. Input approximately 20 pulses to the remote module. Verify that the uncorrected or corrected counts on the IMC/W2 and the remote module are the same.

### Pulse rates for pulse output of Dresser indexes

Table 4 lists pulse rates for the pulse output of compatible Dresser indexes.

**Table 4** GE Oil and Gas meter drive rates by index style and meter size

Index style	8C-11M	16M	16M-56M	1.5-11M	16M-102M
B3 CTR index	10		100		
B3 TC index (Meter built January 1999 and later)	10	100			
B3 TC index (Meter built prior to January 1999)	50	500			
LMMA CTR index				10	100
LMMA TC or Series 3 CTR/TC index		100		10	

## Wiring instructions

This section describes mechanical installation to the Dresser Gas meter and wiring connections.

### D800/D1000 wiring and installation

1. Loosen and remove the two screws holding the mounting brackets to the meter.



After the brackets are removed, the pulse output cable is visible.



2. Loosen the cable gland and pull the cable out until it extends 7.5 to 8 inches out of the cable gland.



3. Tighten the cable gland. Do not use a pliers or wrench to tighten the cable gland.
4. Rotate one bracket. Route the meter cable through the holes located at the bend of the mounting brackets.



5. Attach the brackets to the meter using the previously removed screws.



- Splice the meter pulse output wires to the ERT Module wires using gel cap connectors. Follow the wire connections for the D800/D1000 to ERT Module wire connections as described in [Table 5](#).

**Note:** Use a crimping tool compatible with gel-connectors.

**Table 5** D800/D1000 meter to remote-mount module wiring

D800/D1000 meter			ERT Module		
Pulse output	Wire	Pulse output 1	Pulse output 2	Pulse output 1 with fault	Pulse output 2 with fault
Output 1+	Brown	White and blue		White	
Output 1-	Green	Red		Red	
Output 2+	White		White and blue		White
Output 2-	Black		Red		Red
Output 3+	Red			White	White
Output 3-	Blue			Blue	Blue

- Install a cable tie strain relief on the cable approximately 1/8" from the end of the cable insulation.



- Position the cable so the strain relief is just inside the slot on the module's backplate.



9. Carefully fold the ERT Module wires into the module's housing. Do not pinch the wires of gel connections between the housing and the backplate.



10. Install the four back plate screws using the T-15 Torx screws supplied with the ERT Module.



11. Route the cable through the channel in the backplate standoffs.
12. Insert the 8-32 x 1/2" screw into the top hole in the meter mounting bracket and thread one of the Kep nuts loosely onto the end of the screw.



13. Tilt the bottom of the ERT Module away from the mounting bracket and slide the notched mounting hub onto the screw and Kep nut. Do not tighten the screw.

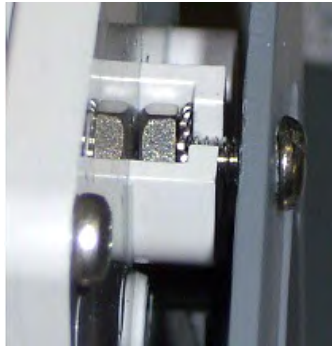

14. Install the bottom two mounting screws and Kep nuts. Tighten the three mounting screws in an alternating pattern.



15. Install the supplied red tamper seals over the bottom mounting screws on the ERT Module.



Next, continue to [Programming and verifying on page 147](#).



## Meters with pulse output wiring

These instructions describe B3 series, LMMA series, IMC, IMC/W2, MC2, and Series ES3 and ETC wiring connections. Installations are similar in their wiring of a meter manufacturer cable to the ERT Module that is then connected to the index or instrument.

**Note:** Wiring connections are different for the models as described. Use the connections for your specific meter model.

1. Remove the backplate (four screws) from the module and expose the module lead wires. The backplate and screws will be re-installed on the ERT Module later in this procedure, so store them (temporarily) in a safe, secure place.

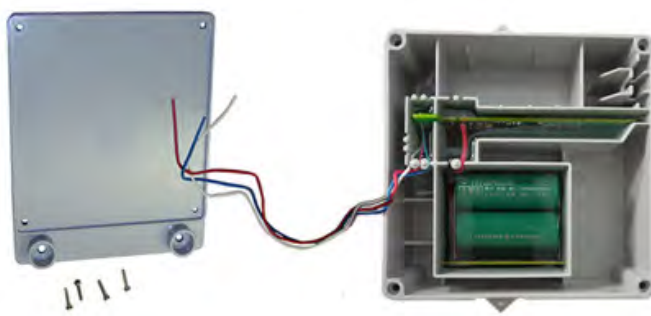

2. Insert the lead wires from the module and the correct Dresser pulse output wire into new 3M gel connectors and crimp using the E-9R 3M gel-cap crimping tool. Wiring configurations are provided in [Table 6](#) and [Table 7](#).

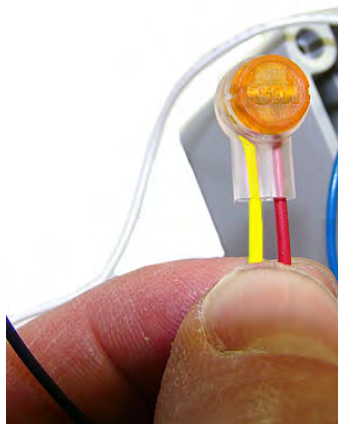

**Note:** Use a crimping tool compatible with gel-connectors. For information about crimping the connections, see [Using gel-cap connectors to complete wiring connections on page 163](#). The same process is used for wiring cables to the ERT Module. Each meter or cable may have different wire colors and wiring instructions. See the specific wiring configuration for your product.

**Table 6** Dresser lead wire to ERT Module wire connections

Dresser-supplied cable that connects to a B3, LMMA, IMC/W2, or IMC2*	ERT Module
Blue	Blue
White	White
Red	Red

\*This is the Itron-specific three-wire cable. Other cable variants do not provide a cut-cable tamper.

**Table 7** Dresser lead wire to ERT Module wire connections (for ES3 or ETC meters)

ES3 or ETC	ERT Module
Output 1+	White
Output 1-	Black
Output 3-	Green

- a. **To receive uncorrected reads:** Connect the red wire to terminal block 3 (TB3 telemetry output) GND1 (ground) position (B). Connect the white and blue wires to the pulse output 1 position (A).

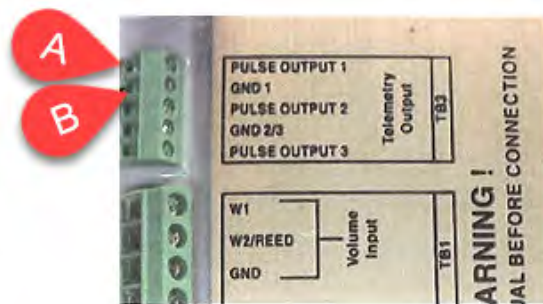

- b. **To receive corrected reads:** Connect the red wire to the GND 2/3 (ground) TB3 telemetry output position (C). Connect the white and blue wires to the pulse output 2 position.

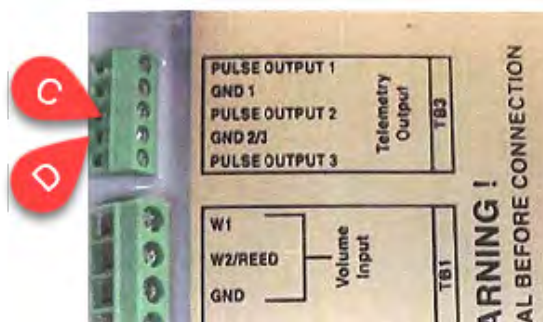

3. After completing the wiring connections, install a cable tie to the meter cable just below the exposed colored lead wires on the cable insulation.

Remove the excess cable tie using a hand-held side-cutter pliers. The cable tie performs as a cable strain relief to mitigate the risk of destructive tension on the lead wires.

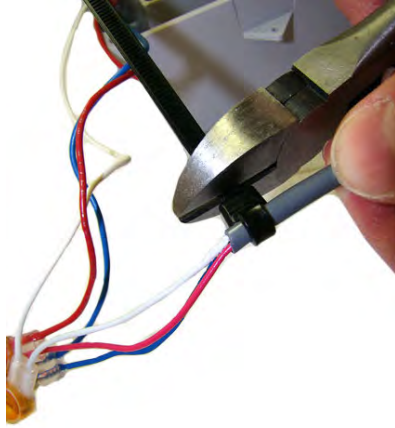

4. Tuck the three gel connectors and cable tie inside the module housing, as shown in the placement illustration and schematic.



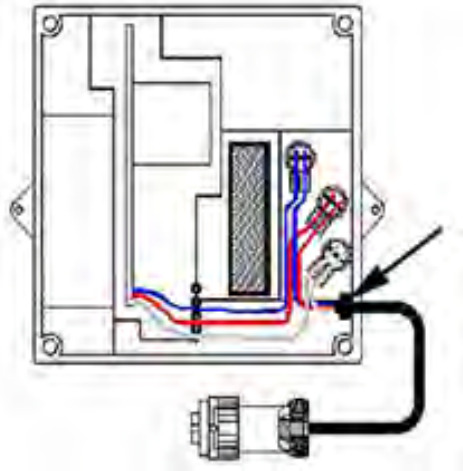

5. Install the module backplate using the four screws previously removed from the module and a Torx T-10 screwdriver.
6. Plug the cable into the pulse output of the index.



**Important!** Verify that the cable tie and gel connectors are inside the module housing and that the cable extends out of the backplate slot. Torque the backplate mounting screws 9 to 12 inch-pounds.

7. Mount the module as required for your application. Wall and pipe mount options are described in [Mounting a remote-mount module on page 156](#). Additional options for Dresser-specific mounting solutions are described in [Custom mounting options on page 101](#).



## Custom mounting options

**Note:** Specific product mounting instructions for GE D800/D1000 meters and meters with pulse output wiring are included in [D800/D1000 wiring and installation on page 93](#) and [Meters with pulse output wiring on page 98](#).

### ES3 or ETC ordered with the AMR-ready mounting kit

These instructions only apply if you are mounting with an ES3 or ETC ordered with the AMR-ready mounting kit and assume you have already completed the procedures



1. Insert the 8-32 by 7/16 inch screw (1) into the top of the mounting bracket. Insert the two 8-32 by 3/4 inch screws (2) into the bottom of the mounting bracket.

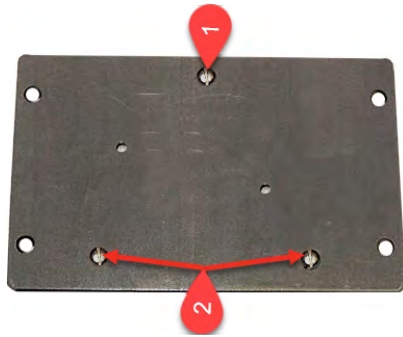

2. Insert one 3/32 inch nut on the top 7/16 inch bracket screw. Slide the ERT Module mounting lug over the top of the bracket screw and nut.

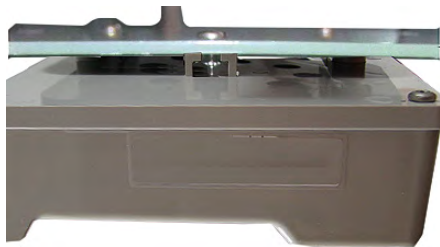

3. Secure the bottom ERT Module mounting holes over the two 8-32 by 3/4 inch screws with the remaining two 8-32 nuts.



4. Insert the #10 spacers into the four mounting holes on the back of the IMCW2.





## Eagle Research

Installing the ERT Module to an Eagle Research volume corrector involves the following tasks.

1. Programming the volume corrector to work with the ERT Module.
2. Wiring the module to the volume corrector.
3. Programming the ERT Module.
4. Mounting the ERT Module. Mounting options include:
  - Wall mount on a sheet metal surface
  - Pipe mount
  - Eagle Research mounting rail (custom option)

ERT Module configuration with the meter is dependent on your system application. See the Eagle Research meter product documentation for the Eagle Research Field Manager database configuration information.

This section provides instructions to install the ERT Module (including part numbers ERG-5006-502, ERG-5600-502, ERG-7000-502, and ERG-7600-502) on compatible Eagle Research meters. Compatible meters include:

- MPplus volume corrector
  - Pulse width: 70 mS and 500 mS off timing
  - Pulse output board required
- XARTU-1 volume corrector
  - Pulse width: 70 mS on and 500 mS off timing
  - Corrector must have Solid State relays

### MPplus Corrector programming

If you are installing with an XARTU corrector, skip to [XARTU Corrector programming on page 107](#).

Using Itron remote-mount modules with Eagle Research volume correctors requires Eagle Research Field Manager software configured with the parameters for your model of Eagle Research corrector. This section describes configuring the software for the MPplus Corrector.

During remote module programming for use with the Eagle Research corrector, verify that the module drive rate settings match those set in the corrector. For example, set the module drive rate for 1000 CF when the Eagle Research corrector drive rate is set for 1000 CF.



**Important!** This information is subject to change without notice. Refer to the Eagle Research product documentation to verify the most current programming and configuration information for the ERT Module.

1. Open the Eagle Research Field Manager from the Start menu or the desktop shortcut.



2. Connect the communications cable from your computer into the MS connector on the side of the MPplus corrector. After the MS connector is connected, take note of the baud rate displayed on the front of the corrector.
3. Click **Connect** on the upper left corner of the Field Manager window. A Connect to Remote window opens.

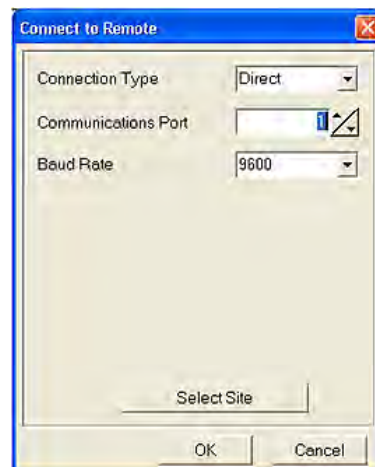

4. Select the following parameters:
  - **Connection Type:** Direct
  - **Communications Port:** enter your computer's port number
  - **Baud Rate:** enter the baud rate that displayed in step 2.
5. Click **OK**.

- Click **View/Config**. The Field Manager window opens and displays the settings for the current connection.



- Click the **Setup Parameters** tab at the bottom of the parameters window. A parameters window opens.
- Enable POut 5 (17, 18) and set the additional parameters as required in the **Uncorrected Pulse Output Setup** at the lower right of the window.

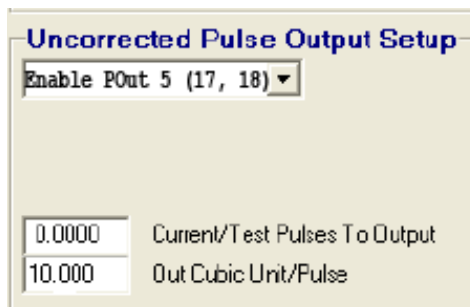

**Important!** If your software does not have an option to use POut for the uncorrected pulse output, contact Eagle Research to get the correct software version.

- Enter the parameters shown in the **Corrected Pulse Output Setup** section in the lower left of the window.

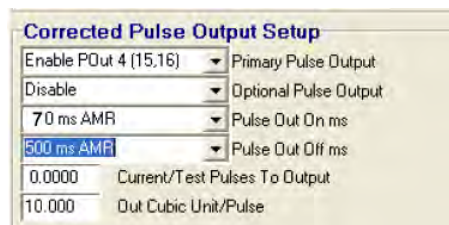

- Click **Send All Changes**.

**Send All Changes**

- Verify that all parameters are correct.
- Click **Disconnect**.

Next, continue to [Wiring to the MPplus Corrector on page 109](#).

## XARTU Corrector programming

Using Itron remote-mount modules with Eagle Research volume correctors requires Eagle Research Field Manager software configured with the parameters for your model of Eagle Research corrector. This section describes configuring the software for the XARTU corrector.

During remote module programming for use with the Eagle Research corrector, verify that the module drive rate settings match those set in the corrector. For example, set the module drive rate for 1000 CF when the Eagle Research corrector drive rate is set for 1000 CF.



**Important!** This information is subject to change without notice. Refer to the Eagle Research product documentation to verify the most current programming and configuration information for the ERT Module.

1. Open the Eagle Research Field Manager from the Start menu or the desktop shortcut.



2. Click **Connect** on the upper left corner of the Field Manager window.



3. Select the following parameters:
  - **Connection Type:** Direct
  - **Communications Port:** Enter your computer's port number.
  - **Baud Rate:** Enter the baud rate for the XARTU-1 corrector.
4. Verify that the time and station name are correct.
5. Click **View/Config**.



6. Click **OK**.
7. Click the **Setup Parameters** tab at the bottom of the parameters window.

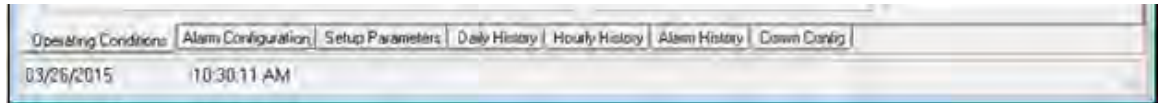

8. The Meter Setup and Accumulation Multipliers window opens. Set up the meter and accumulation multipliers as appropriate for your installation.

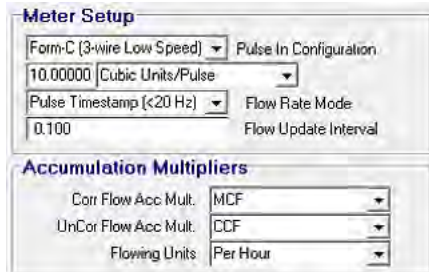

9. Enable K2 (4, 5, 6) and set additional parameters are required in the **Uncorrected Pulse Output Setup** section in the lower right of the window.

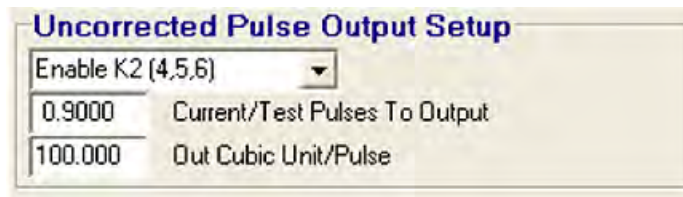

10. Set the *Primary Pulse Output* to Enable K1 (1, 2, 3) and the *Optional Pulse Output* to Disable (unless it is used for another application) in the Corrected Pulse Output Setup section in the lower left of the window.

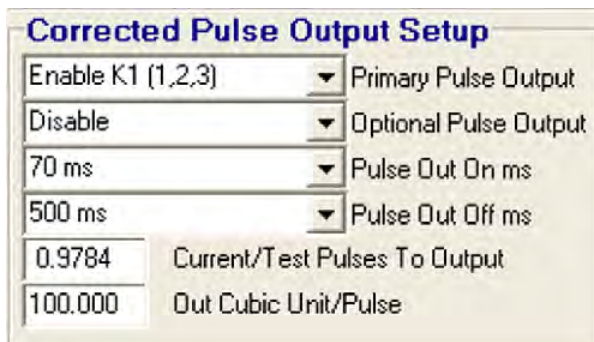

11. Click **Send All Changes**.

A red rectangular button with the text "Send All Changes" in white.

12. Verify that all parameters are completed and correct.
13. Click **Disconnect**.

Next, continue to [Wiring to the XARTU corrector on page 110](#).

## Wiring instructions

This section provides wiring and connection information for compatible Eagle Research products. Refer to the instruction for your product type.

- [Wiring to the MPplus Corrector on page 109](#)
- [Wiring to the XARTU corrector on page 110](#)

### Wiring to the MPplus Corrector

1. With the MPplus door open, insert the flying leads from the remote module into the compression connector on the left of the MPplus housing.
2. Pull the lead wires through the compression connector until there is adequate wire to reach the terminal blocks labeled 15, 16, 17, 18, 19, 20, 21, and 22.
3. Tighten the compression connector.
4. Twist the remote module's blue and white wires together.

For uncorrected reads, continue to step 5. For corrected reads, skip to step 7.

#### For uncorrected reads

1. Connect:
  - the twisted blue and white wires to terminal 17 on the MPplus terminal block.
  - the red remote module wire to terminal 18 on the MPplus terminal block.

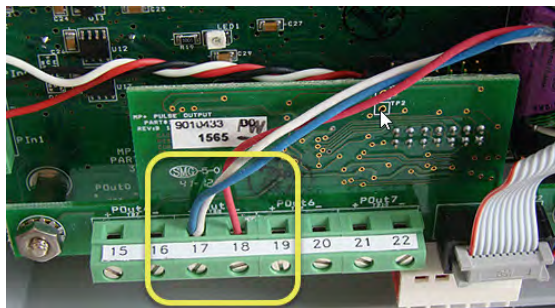

2. Close and latch the MPplus corrector door.

Next, continue to [Programming and verifying on page 147](#).



**For corrected reads**

1. Connect the twisted blue and white wires to terminal 15 on the MPplus terminal block.
2. Connect the red remote module wire to terminal 16 on the MPplus terminal block.

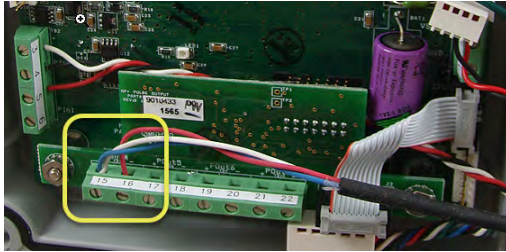

3. Close and latch the MPplus corrector door.



Next, continue to [Programming and verifying on page 147](#).

**Wiring to the XARTU corrector**

This section describes how to connect to the XARTU corrector.

**For uncorrected reads**

1. Insert the flying leads from the remote module into the compression connector on the right of the XARTU-1 corrector housing.



2. Pull the lead wires through the compression connector until there is adequate wire to reach the K2 terminal port.

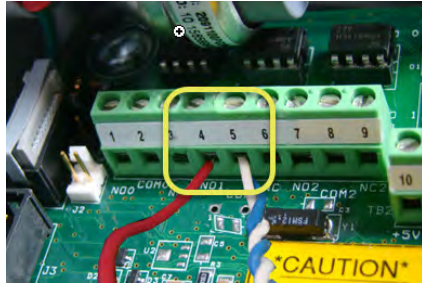

3. Tighten the compression connector.
4. Connect the red remote module wire to pin 4 of the K2 terminal port.
5. Twist the remote module's blue and white wires together and connect the twisted blue and white wires to pin 5 of the K2 terminal port.
6. Plug the MTA battery connector from the battery pack into the VBAT1 connector to supply power to the XARTU-1 corrector.
7. Close and latch the corrector door.

Next, continue to [Programming and verifying on page 147](#).

#### For corrected reads

1. With the XARTU door open, insert the flying leads from the remote module into the compression connector on the left of the corrector's housing.



2. Pull the lead wires through the compression connector until there is adequate wire to reach the K1 terminal port.
  - K1
  - K2
  - K3
3. Tighten the compression connector.

4. Connect the red remote module wire to pin 1 on the K1 terminal port.
5. Twist the remote module's blue and white wires together.

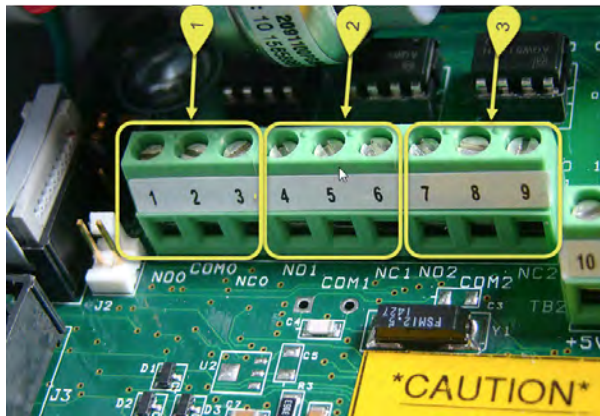

6. Connect the twisted blue and white wires to terminal 2 on the K1 terminal port.

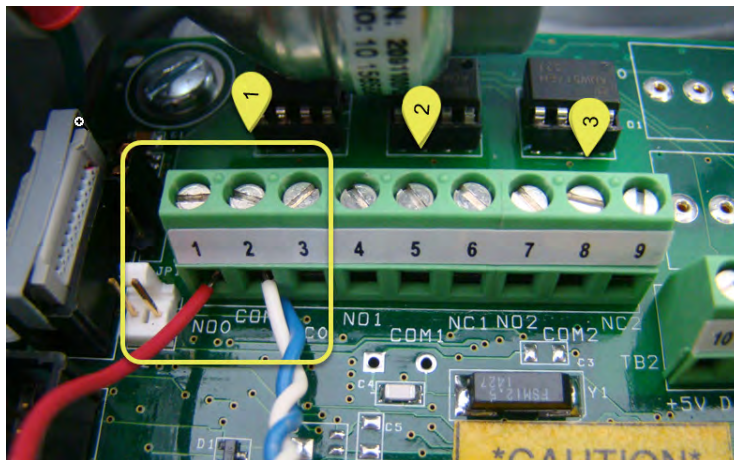

Next, continue to [Programming and verifying on page 147](#).

## Mounting with Eagle Research mounting rail

These instructions only apply if you are mounting the ERT Module on Eagle Research's mounting rail and assume you have already completed the procedures described in [Programming and verifying on page 147](#). Otherwise, continue to [Mounting a remote-mount module on page 156](#).

This mounting information describes installation for two remote modules—one for corrected reads and one for uncorrected reads. Installation is the same for both configurations (corrected or uncorrected). Eagle Research meter outputs are optically isolated from the meter control board and from each other. The volume corrector software configuration controls the port operation. Follow the Eagle Research documentation and these Itron instructions to ensure the correct compatibility and installation.

**Note:** These instructions show the Eagle Research MPplus volume corrector. Installation is the same for the XARTU-1 corrector.

1. Mount a remote module on each end of the mounting rail using the mounting screws supplied with the modules.

**Note:** The notch in the mounting rail is the front bottom of the rail. The modules mount to the back of the mounting rail.



2. Insert tamper seals into the tamper seal mounting cups on the remote modules.



3. With the corrector facing forward, align the corrector mounting holes with the index drive mounting holes.
4. Insert the corrector's mounting screws in the front corrector and index mounting holes. Loosely tighten the front two mounting screws.
5. Align the inside mounting rail screw holes over the back index and corrector mounting screw holes.
6. Insert the two remaining mounting screws in the corrector bracket mounting holes.
7. Tighten all four mounting screws.



## Elster American

Some meter manufacturers provide module mounting kits and installation procedures for their meters. If the Elster American RPM meter to the ERT Module installation instructions are not available, follow the installation procedures in this section.

Installing the ERT Module to an Elster American meter involves four tasks.

1. Programming or verifying that the meter is set up to work with the ERT Module.
2. Wiring the module to the meter.
3. Programming the ERT Module.
4. Mounting the ERT Module (for mounting information, see [Mounting a remote-mount module on page 156](#)). Select the mounting option appropriate for your installation.

Mounting options include:

- Wall mount on a sheet metal surface
- Pipe mount
- Custom Elster American meter mounting option

This section provides instructions to install the ERT Module on compatible Elster American meters. Compatible meters include:

- 10 Metric (10B)
  - Originally manufactured by Metric Metal Works
  - Compatible with part numbers ERG-5006-501, ERG-5600-501, ERG-7000-501, and ERG-7600-501
- Elster American RPM Series rotary meter
  - Meter must have factory-installed pulser with connector output. Purchase correct cable interface from manufacturer.
  - Compatible with part numbers ERG-5006-503, ERG-5600-503, ERG-7600-503, and ERG-7000-503

## Wiring instructions

**Note:** Connection to an Elster American meter requires a cable interface compatible to an Elster American RPM rotary meter.

1. Trim the ERT Module wires to 3.5 inches.



2. Carefully strip the insulation covering from the meter cable (purchased from the meter manufacturer) approximately 1 to 1.5 inches from the end.



**Caution:** Do not cut through the individual wire insulation.

3. Separate the meter cable's black, white, and red wires for connection to the remote module. Cut off the unused wires even with the outer covering (insulation).



**Caution:** Do not strip the individual wires.

4. Connect the meter cable to the ERT Module's wires using 3M gel-cap connectors. Follow the wiring information in [Table 8](#) and the figure below.



**Important!** Use a crimping tool compatible with gel-connectors. *Do not* use standard pliers for crimping gel-connects. For more information, see [Using gel-cap connectors to complete wiring connections on page 163](#).

**Table 8** American RPM meter to remote module wire connection information

American meter wire	Remote module wire
Black	Blue
White	White
Red	Red



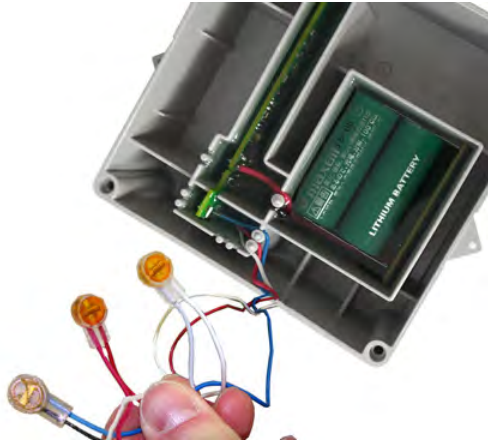

5. Insert the meter cable through the slot on the remote module backplate. Install a cable tie to the meter cable wire below the meter cable insulation to provide strain relief.

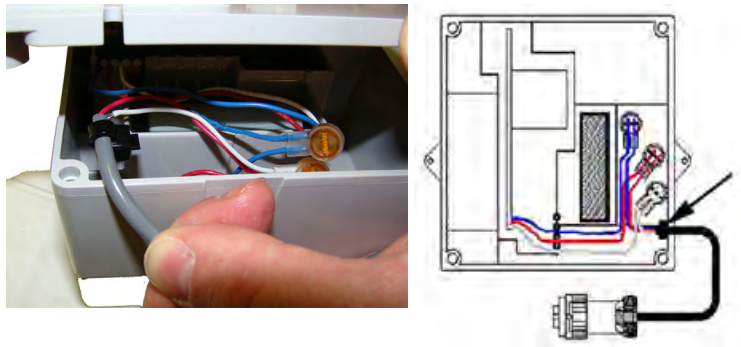

6. Tuck the connectors and cable tie into the remote module housing.
7. Place backplate on the assembly and tighten the four backplate screws using a size T10 Torx screwdriver.



**Important!** Verify that the cable tie and gel connectors are inside the module housing and that the cable extends out of the slot in the backplate. Torque the backplate mounting screws to 9 to 12 inch-pounds.



## Installing the ERT Module's cable

1. Insert the plug on the cable connected to the module into the receptacle on the meter adapter plate.

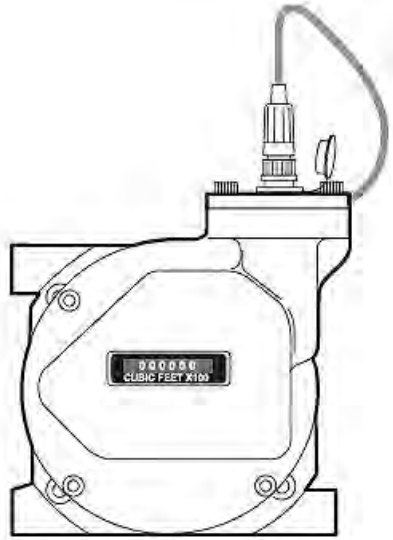

2. Tighten the threaded collar on the plug onto the American Meter interface receptacle. Verify that the connection is hand-tight.

Next, continue to [Programming and verifying on page 147](#).

## Mounting with Elster American-specific mounting method

These instructions only apply if you are mounting with an Elster American-specific mounting method and assume you have already completed the procedures described in [Programming and verifying on page 147](#). Otherwise, continue to [Mounting a remote-mount module on page 156](#).

1. Remove the meter's top plate by removing the two five millimeter screws and carefully prying up on the plate. The plate is secured with an O-ring seal. Remove the O-ring from the plate.



**Caution:** If the O-ring is damaged during removal, obtain a replacement from Elster American Meter Co.

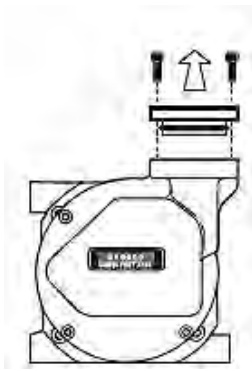

2. Look into the meter tower and find the meter switch lead and connector (4-pin).

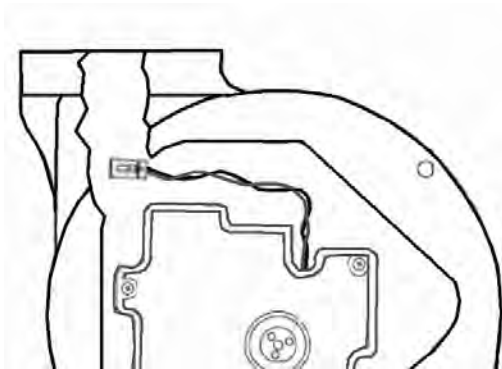

3. If the lead and connector are not visible or cannot be found, remove the four five millimeter mounting screws and the register cover. The meter switch lead and connector will be visible inside the cover.

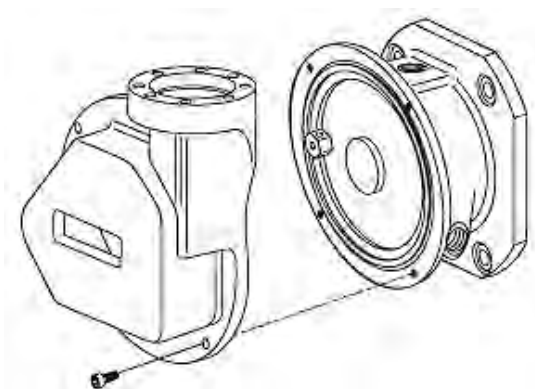

4. Feed the lead and connector into the register cover tower.

**Note:** Save any meter tags. You will re-install them later in the installation process.

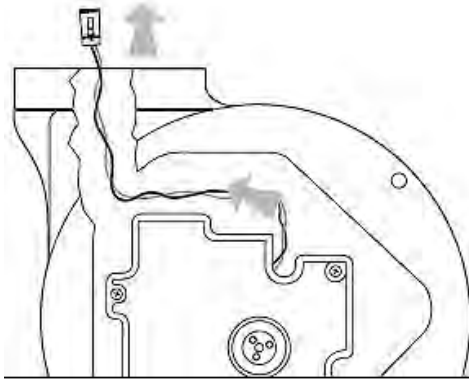

5. If you removed the register cover, replace the cover using the four 5 mm mounting screws.

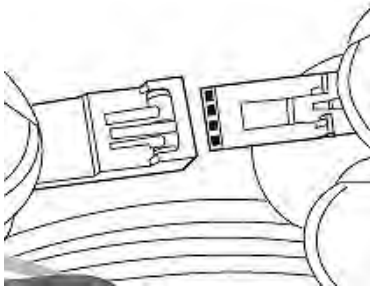

6. Attach the four-pin male connector on the Elster American Meter adapter plate to the four-pin female connector inside the meter's tower. The connectors slide together and latch.
7. Carefully push the connectors and wires into the meter tower housing.

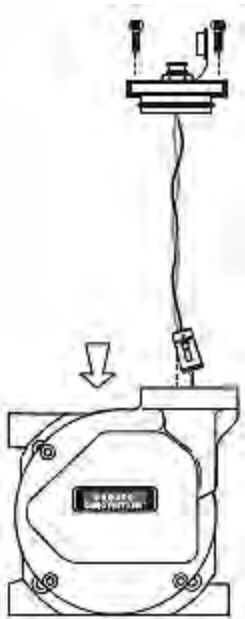

8. Lubricate the O-ring with O-ring lubricant and install the O-ring on the adapter plate. Insert the adapter plate into the tower and tighten the two five millimeter screws.

## Galvanic Gas Micro

Installing the ERT Module to a Galvanic volume corrector involves four tasks.

1. Programming or verifying that the volume corrector is set up to work with the ERT Module.
2. Wiring the module to the volume corrector.
3. Programming the ERT Module.
4. Mounting the ERT Module. Mounting options include:
  - Wall mount on a sheet metal surface
  - Pipe mount

This section provides instructions to install the ERT Module (including part numbers ERG-5006-503, ERG-5600-503, ERG-7600-503, and ERG-7000-503) on compatible Galvanic Gas Micro meters. Compatible meters include:

- Gas Micro Electronic Volume Corrector
  - In the meter, you must select two pulses/second from pulse output on the output frequency menu.

**Note:** ERT Module cut cable requires a customer-supplied cable capable of terminating the module's white and blue wires at the meter interface.

## Mechanical and wiring installation instructions

**Table 9** GAS Micro wiring connections

GAS Micro corrector	P13 connection	ERT Modules
Pulse output1-C	C1	Blue/white
Pulse output1-E	C2	Red
Pulse output2-E	C3	
Pulse output2-C	C4	

## Mounting instructions

See the Galvanic product documentation for custom mounting instructions.

## Honeywell Instrument

Installing the ERT Module to a Honeywell Instrument involves the following tasks.

1. Programming the instrument to work with the ERT Module.
2. Wiring the ERT Module to the instrument.
3. (As required) Installing the instrument and any required retrofit components.
4. Programming the ERT Module.
5. Mounting the ERT Module. Mounting options include:
  - Pipe mount
  - Wall mount
  - Custom Honeywell mounting

This section provides instructions to install the ERT Module on compatible Galvanic Gas Micro meters. Compatible meters include:

- Temperature Compensating Index (TCI). Note the following:
    - Compatible with ERT Module (including part numbers series ERG-5006-502, ERG-5600-502, ERG-7000-502, and ERG-7600-502 as well as ERG-5006-503, ERG-5600-503, ERG-7600-503, and ERG-7000-503).
- Note:** The -502 module has a five-foot cable and is used when longer cabling is required. This module will return the cut cable tamper. The -503 module has lead wires designed for use with the TCI mounting bracket. This module returns the cut cable tamper alarm.
- The TCI must have a Form A board.
  - Form C is not supported.
  - Item #56 Pulse Scaling Factor must be 2.0.
  - Compatible TCI firmware versions are 1.06, 1.07, and 1.10.
- EC 350 Electronic Volume Corrector (EC350). Note the following:
  - Compatible with ERT Module (including part numbers ERG-5006-502, ERG-5600-502, ERG-7000-502, and ERG-7600-502).
- IN-Z61. Note the following:
  - Compatible with ERT Module (including part numbers ERG-5006-502, ERG-5600-502, ERG-7000-502, and ERG-7600-502).
  - IN-Z61 is a retro-fittable Low Frequency (LF) pulser for all Elster-Instromet diaphragm gas meters BK-G1.6 to BK-G100.
- Mini-AT, Mini-Max, and EC-AT. Note the following:
  - Compatible with ERT Module (including part numbers series ERG-5006-502, ERG-5600-502, ERG-7000-502, and ERG-7600-502 as well as ERG-5006-503, ERG-5600-503, ERG-7600-503, and ERG-7000-503)

- These are pressure and temperature electronic volume instruments. Instruments must have a Form A board.
- Form C is not supported.
- Item #56 Pulse Scaling Factor must be 2.0.
- Item #96 Cor Vol Display must be 7, 6, 5, or 4 digits (1, 2, 3, or 4 blanks).
- Item #115 Output Pulse Code must be set at 1, 2, or 4.
- *(For connection to Mini-Max only)* Item #115 must be set at 1 or 2.
- Item 124 wake up setting on Honeywell corrector must be set to 1.
- Compatible corrector firmware versions are 2.5020 and 2.73.

## Programming

The Honeywell MasterLink SQL software is used to configure Honeywell products.



**Important!** This information is subject to change without notice. Refer to the Honeywell MasterLink SQL product documentation to verify the most current information about programming and configuring the corrector for use with the ERT Module.

### Software settings

1. Connect the interface cable from the Honeywell instrument to a PC loaded with the MasterLink SQL software.
2. Open the MasterLink SQL software. The software opens and reports a “Not Connected” status.

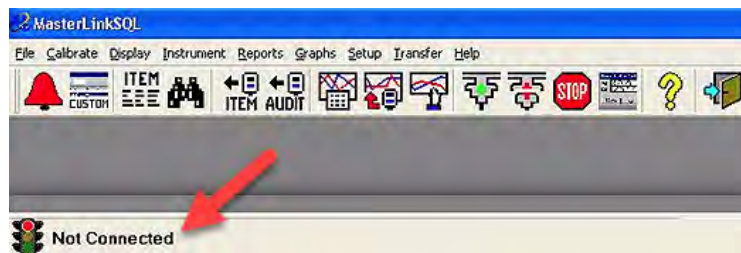

The Site List window automatically opens after the software detects an instrument.

3. Select the Honeywell instrument type from the **Instrument List** on the right of the screen.



**Important!** You must select the correct instrument type. Selecting the incorrect type causes communication errors.

4. The status indicator in the lower left corner of the MasterLink SQL software displays the connection status as Connected (instrument type).



- To view an Item configuration, select **Display > Items by Number**.

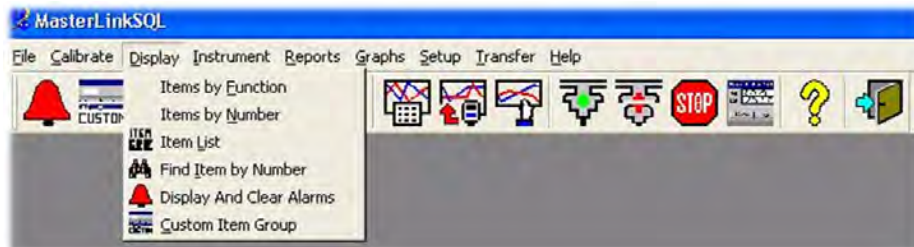

- Verify that the Honeywell instrument settings are correct. For example, Item number 56 must be set to 2.0. If the setting is incorrect, click **Change**.

The screenshot shows the "Display/Change Items By Number" dialog box. It contains a search field and a table of items. The table has columns for "Number", "Description", "Value", and "Units". Item 56 is highlighted.

Number	Description	Value	Units
042	Excess T Cal Change %	2.0000	
043	Total Correction Factor	1.2305	
044	Press Correction Factor	0.9937	
045	Temp Correction Factor	1.2383	
046	Aux Correction Factor	1.0000	
047	Unsquarded Supercompress	1.0000	
048	Battery Voltage Reading	5.84	Volts
049	Batt Low Volt Limit	4.30	Volts
050	Shutdown Voltage Limit	4.00	Volts
053	Specific Gravity For Sp	0.6000	
054	% N2 For Supercompress	0.0000	%
055	% CO2 For Supercompress	0.0000	%
056	Pulser A Out Scaling	2.0000	
057	Pulser B Out Scaling	2.0000	
061	Display Test	88888888	
062	Corrector Serial Number	13011577	
075	Meter Rdr List 2 Itm 1	48	Battery Voltage Reading
076	Meter Rdr List 2 Itm 2	255	Reserved
077	Meter Rdr List 2 Itm 3	255	Reserved
078	Meter Rdr List 2 Itm 4	255	Reserved
079	Meter Rdr List 2 Itm 5	255	Reserved
080	Meter Rdr List 2 Itm 6	255	Reserved
081	Meter Rdr List 2 Itm 7	255	Reserved
082	Meter Rdr List 2 Itm 8	255	Reserved
083	Meter Rdr List 2 Itm 9	255	Reserved
084	Meter Rdr List 2 Itm 10	255	Reserved

A Change Item pop-up provides the interface to change the setting.



- Enter the correct setting. Click **Save**.
- Confirm that all settings match the settings required for the module connected to the Honeywell Instrument. For more information, see compatible modules listed in [Honeywell Instrument on page 120](#).

## Programming parameters



Program the Honeywell Instrument parameters following the settings described [Table 10](#).

Also note the following terminal board connections/wiring:

- Red ERT Module wire goes to K connection.
- Blue and white ERT Module wires go to Y connection. Must be on same terminal board channel (for example, Ka/Ya; Kb/Yb; Kc/Yc)
  - Ka, Ya = Channel A
  - Kb, Yb = Channel B
  - Kc, Yc = Channel C

**Table 10** Item code settings

Instrument	Pulse output options	Channel A corrected volume		Channel B uncorrected volume		Channel C		Pulse output spacing		
		#56	#93	#57	#94	#58	#95	#115	#1014	#1015
ECAT	Pulse Board Ver-2 (3) Form A	2	Cor Vol	2	Unc Vol	2	Cor Vol	1=1.0 sec or 2=2.0 sec or 4=0.5 sec		
ECAT	Pulse board Ver-3 (2) Form C1 Form A					2	Cor Vol	1=1.0 sec or 2=2.0 sec or 4=0.5 sec		
Mini with Form A main board	Main board Type-2*	2	Cor Vol					1=1.0 sec or 2=2.0 sec or 4=0.5 sec		

**Table 10** Item code settings (continued)

Instrument	Pulse output options	Channel A corrected volume		Channel B uncorrected volume		Channel C		Pulse output spacing		
		#56	#93	#57	#94	#58	#95	#115	#1014	#1015
Mini-AT	JB29, JB30 & JB31 Jumpered for Form A*	2	Cor Vol	2	Unc Vol			1=1.0 sec or 2=2.0 sec or 4=0.5 sec		
Mini-Max	All main boards	2	Cor Vol	2	Unc Vol			1=1.0 sec or 2=2.0 sec		
TCI	Form A main board	2	Cor Vol	2	Cor Vol				ERT Module	ERT Module

## Wiring instructions

This section includes the information to wire two ERT Modules to a single Honeywell Instrument. Installation requires the correct programming parameters (for programming parameters, see [Programming and verifying on page 147](#)).

### Wiring to a Honeywell Mini-AT, Mini-Max, or EC-AT

With Itron remote modules, utilities can receive *corrected* and *uncorrected* consumption values by installing two modules. The module for *corrected* reads is attached to the corrector's pulse output. The module for *uncorrected* reads is attached to the input switch board. The *corrected* pulse output is programmable, and the *uncorrected* pulse output is dependent on the connected meter's drive rate.



**Important!** Some Honeywell Instruments have two pulse outputs so the *uncorrected* pulse output could be connected to the additional output, but the connection should be to the input switch board in case the corrector battery fails. Counts will be collected if the *uncorrected* pulse is connected to the switch board since the board is not dependent on battery power.

This installation procedure requires a Honeywell mounting kit (contact Honeywell for the kit part number). The illustrations show connection to a Honeywell Mini-AT. Connection to the Honeywell EC-AT and Mini-AT are similar to these instructions. See Honeywell product documentation for more information.

1. Connect the *corrected* module wires to TB1 on the Mini-Max board following the Corrected module connection information. Use Honeywell upgrade kit 40-2678-1 to provide the second pulse output channel for the uncorrected endpoint.
2. Insert the remote module cable into the instrument's compression connector.

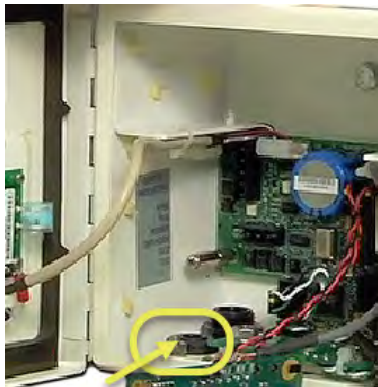

3. Strip one inch of the outer insulation from the cable.



**Warning!** Keep wires away from the rotating magnetic spindle in the Honeywell Instrument.

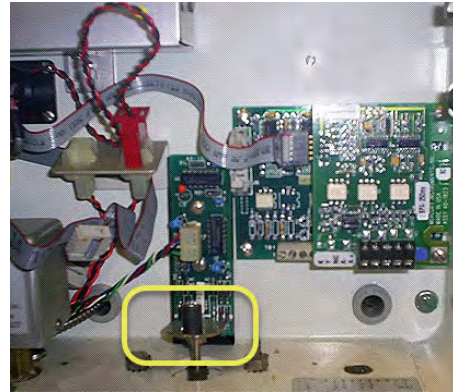

4. Strip 1/4-inch individual wire insulation from the red, white, and blue lead wires.
  - Count enabling wire (pulsed ground reference)
  - Count sensing wire (high impedance positive reference)
  - Cut cable sensing wire (positive return)

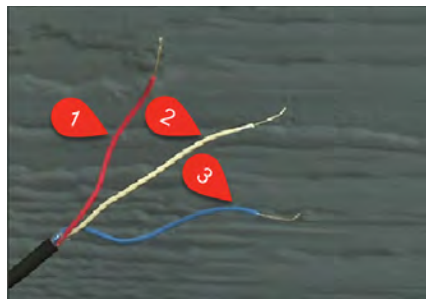

5. Twist the blue and white wires together and connect them to the Honeywell Instrument terminal strip connector (Phoenix connector) following the Honeywell Instrument Item Code Settings. For Item Code Settings, see [Program the Honeywell Instrument parameters following the settings described Table 10. on page 124.](#)



6. Connect the red wire following the Item Code Settings. For Item Code Settings, see [Program the Honeywell Instrument parameters following the settings described Table 10. on page 124.](#)

**Note:** In Honeywell Instrument EC-AT correctors, the connector may be soldered to the pulse board.

**Table 11** Corrected module connections

Mini-Max TB1	Module wire color
K terminal	Red
Ya terminal	Blue*
Ya terminal	White*

\*Twist the blue and white module wires together before connecting them to the Mini-Max board. Tighten the terminal connection securely.

7. Connect the *uncorrected* module wires to the Input Switch Board UNC. VOL following [Table 12](#).

**Table 12** Uncorrected module connections

Mini-Max input switch board unc. vol	Module wire color
COM terminal	Red
No terminal	Blue*
No terminal	White*

\*Twist the blue and white module wires together before connecting them to the Mini-Max board. Tighten the terminal connection securely.

8. Tighten the large strain relief securely.



**Warning!** Do not crush the module through-cables when tightening the strain relief.

9. Re-install or reconnect the power or battery sources.
10. Close the instrument case and tighten the case screw securely. Replace any locks that were removed for installation.

Next, continue to [Programming and verifying on page 147](#).

### Wiring to the Honeywell TCI

The Honeywell Instruments Temperature Compensating Index (TCI) provides two Form-A volume pulse outputs and one Form-B alarm output. These outputs are electronic

switches. The Form-A pulse outputs are configurable for compensated or uncompensated volume. The Form-B output is for alarm output use only.



Connections to the three output pulse channels are completed using loose unterminated wires (the individual wires from a cable) and gel-connectors. The TCI unit has six unterminated wires that require six gel-connectors (Itron part number CON-0023-001) to enable pulse connections to ancillary devices. Loose wires are located inside the gray adapter plate behind the black strain relief fitting.

<p><b>Strain relief fitting</b></p>	<p><b>Honeywell TCI strain relief tether</b></p>	<p><b>Honeywell backplate black fitting with loose cable wires</b></p>

### Completing the connections

1. Connect the remote module to receive TCI pulse readings.

**Note:** Connect one module/channel to the alarm output if the modules are used on channels A and B.

2. Remove strain relief fitting by unscrewing it from the gray adapter plate.

**Note:** Do not remove the fitting's hex nut. Unscrew the entire fitting from the gray adapter plate. A tether line is secured to the strain relief fitting. When the strain relief fitting is removed, the tether line pulls the unterminated wires out of the adapter plate for access to the loose wires.

3. Loosen the strain relief fitting hex nut and remove the white plug from the center.
4. Place the strain relief fitting onto the field pulse cable.

- If the field pulse cable is smaller than a 0.2 inch diameter, install the rubber tube supplied with the TCI onto the cable so the strain relief will clamp onto the tube after it is reinstalled.



- Connect the individual external pulse cable conductors to the unterminated wires based on [Table 13](#).

**Table 13** Configuration for two modules connected to one TCI

Channel A	Module wire
Orange and brown	White
Yellow	Red
Blue (alarm)	Blue
Channel B	
TCI	Module wire
White	White
Green	Red
White	Blue

- Insert one unterminated wire into an opening of a gel-connector (six gel-connectors were included with the TCI).
- Insert the appropriate field cable wire into the other gel-connector opening.

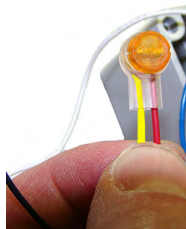

- Verify that both wires are fully inserted into the gel-connector prior to crimping.



**Important!** Use a crimping tool compatible with gel-connectors. *Do not* use standard pliers for crimping gel-connects. See [Using gel-cap connectors to complete wiring connections on page 163](#).



10. Insert the gel-connected wires into the threaded gray adapter plate hole.



11. Replace the strain relief and tighten until secure.

Next, continue to [Programming and verifying on page 147](#).

## Mounting with Honeywell-specific setup

These instructions only apply if you are mounting with a Honeywell-specific mounting method and assume you have already completed the procedures described in [Programming on page 122](#). Otherwise, continue to [Mounting a remote-mount module on page 156](#).

1. Place the Honeywell Instrument volume corrector in shutdown condition and disconnect all power from the Mini-Max main board.
2. Remove the battery pack from the volume corrector and set it aside.
3. Remove the four screws from the main board and the board from the enclosure. Set the board aside.
4. Remove the two hex screws from the input switchboard and the switchboard from the enclosure and set it aside. You will re-install the switchboard later.



**Warning!** The battery pack, main board, and switchboard may be damaged if left in the Honeywell Instrument volume corrector while completing this installation.

5. Drill two 3/16 inch holes in the back of the Mini-Max enclosure as specified by the information included in the kit. Remove any metal shavings from the enclosure.
6. Clean the remote modules with the alcohol wipe where you will place the corrected and uncorrected labels (included in the kit).
7. Mount the module for corrected pulse outputs on the left bracket mounting space.
  - a. Insert three #8-32 by 1/2 inch screws in a triangular pattern.

Install the top screw so the head of the screw is approximately 1/8 inch from the mounting bracket surface.

- b. Slide the module onto the screw so the mounting lug fits securely onto the screw. If necessary, remove the module and make any necessary adjustment to the screw depth to ensure a secure fit.
    - c. Install the two bottom screws in an alternating fashion.
  8. Mount the module for uncorrected pulse outputs on the right bracket mounting space.
    - a. Insert three #8-32 by 0.5 inch screws in a triangular pattern.

Install the top screw so the head of the screw is approximately 1/8 inch from the mounting bracket surface.
    - b. Slide the module onto the screw so the mounting lug fits securely onto the screw. If necessary, remove the module and make any necessary adjustment to the screw depth to ensure a secure fit.
    - c. Install the two bottom screws in an alternating fashion.
  9. Route the module cables under the bracket edge and toward the rear of the Honeywell Instrument.
  10. Mount the mounting bracket (included in the kit) onto the Mini-Max enclosure.
    - a. Place a #8 metal flat washer followed by a rubber sealing washer onto both #8-32 by 3/8-inch screws.
    - b. Align the lower threaded holes in the mounting bracket with the drilled enclosure holes and insert a screw/washer through the enclosure housing. Screws heads must be inside the enclosure.
    - c. Tighten both screws using a screwdriver.

**Note:** Aligning the second bracket threaded hole and drilled hole may require some manipulation of the mounting bracket.
  11. Insert the module cables (both units) through the large cable strain relief on the left rear of the instrument's enclosure. Leave a 0.5- to 1-inch drip loop under the cable strain relief.
  12. Secure three cable ties on the module cables in three places on the cables as specified by information included in the kit.
  13. Re-install the input switchboard, main board, and battery pack removed in step 2.



## Itron Meter

See [Diaphragm meter on page 14](#) for Itron meter installation information.

The ERT Module (including part numbers ERG-5006-501, ERG-5600-501, ERG-7000-501, and ERG-7600-501) can be remote-mounted on compatible Itron meters:

- Itron 1A
  - Flat-face meter where meter body and 1A adapter plate have interference fit issue causing direct mount solution to be non-compatible
- Itron 305
  - #2 flat-face meter
- Itron 400
  - #3 flat-face meter
- Itron 675, 1000
  - Front-mount index
  - The ERT Module requires a thicker gasket for magnet hub to clear the index box. See [Diaphragm meter on page 14](#).

## National meter

See [Diaphragm meter on page 14](#) for National meter installation information.

The gas ERT Module (including part numbers ERG-5006-501, ERG-5600-501, ERG-7000-501, and ERG-7600-501) can be remote-mounted on all National/Lancaster meters. The ERT Module remote-mount installation is advised where direct-mount installation is not compatible.

## Romet meter

Installing the ERT Module to the Romet series correctors involves the following tasks:

1. Programming the corrector to work with the ERT Module.
2. Wiring the ERT Module to the corrector.
3. Programming the ERT Module.
4. Mounting the ERT Module. Mounting options include:
  - Wall mount on a sheet metal surface
  - Pipe mount
  - Custom Romet mounting

This section provides instructions to install the ERT Module (including part numbers ERG-5006-503, ERG-5600-503, ERG-7600-503, and ERG-7000-503) on compatible Romet meters. Compatible meters include:

- RM Series STD CTR 600-5600 TC 2000-23000. Note the following:
  - The meter must have factory-installed pulser with connector output. Purchase a cable interface from the manufacturer.
- Romet RM rotary meter (all series between RM600 to RM56000). Note the following:
  - The meter must have connector pin with factory-installed pulse output. Purchase the correct cable interface from Romet.
- AdEM<sup>®</sup> Series Correctors, including AdEM-S<sup>®</sup>, AdEM-T<sup>®</sup>, and AdEM<sup>®</sup>-PTZ. Note the following:
  - The meter must be configured to 350 ms of output pulse spacing and 30 ms of output pulse width.

## AdEM programming

**Note:** Meter setup requires confirmation of communication settings with the AdEM corrector. Communication confirmation requires the RometLink software and the Romet communication cable.

1. Install the RometLink software on your PC.
2. Connect the AdEM corrector communication cable to your computer and the AdEM corrector.
3. Add the AdEM meter to your *Phone Book*.
  - a. Open the RometLink software and sign in.
  - b. From the *Talk to Unit* tab, select **Check > All**. A dialog box opens asking if you want to add the unit in the *Phone Book*.
  - c. Click **Yes**.

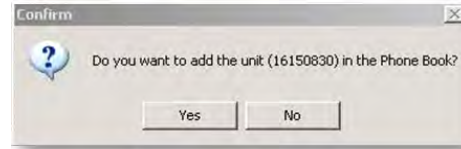
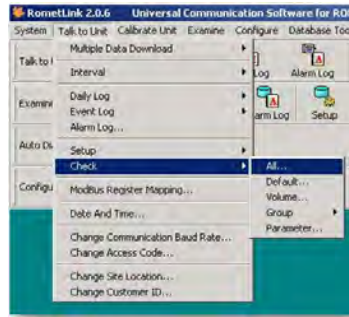

d. Click **Close**.

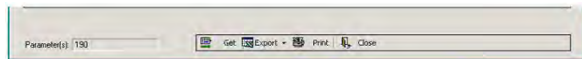

e. Confirm that the meter was added to the Phone Book.

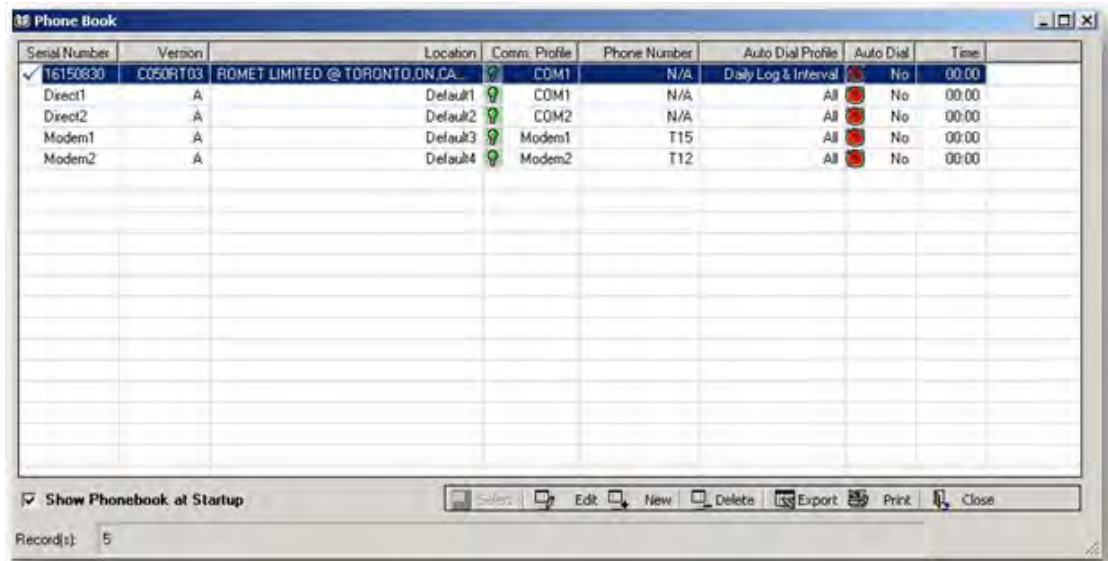

f. Set up the corrected or uncorrected parameters.

g. From the *Talk to Unit* tab, select **Setup > Default**.

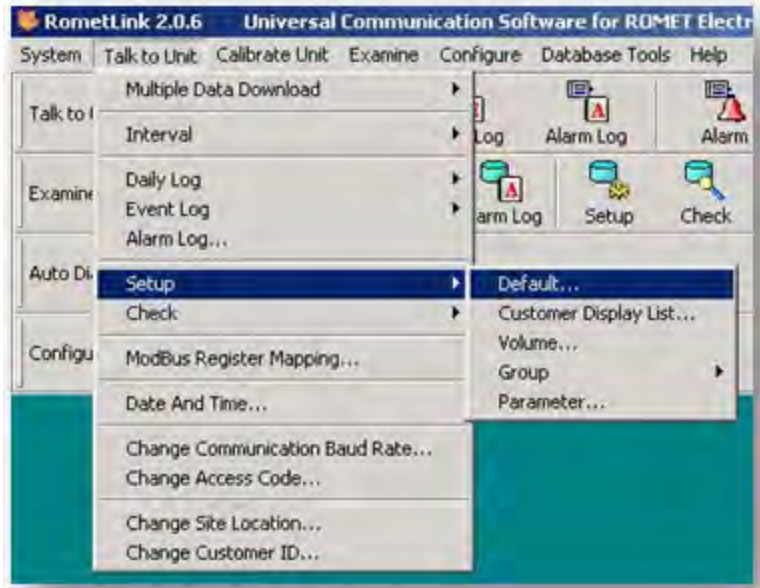

h. Set the following *Default Setup Group* parameters:

- Enter the desired **Cor. Volume Unit** parameter.
- Set **Cor. Pulse Volume** to the same number of units as **Cor. Volume Unit**.
- For **Output Pulse Spacing**, enter the largest number over 285mS that works for your application. Itron recommends a setting of **350 ms**.
- For **Output Pulse Width**, enter the largest number over 28 ms that works for your application. Itron recommends a setting of **30 ms**.

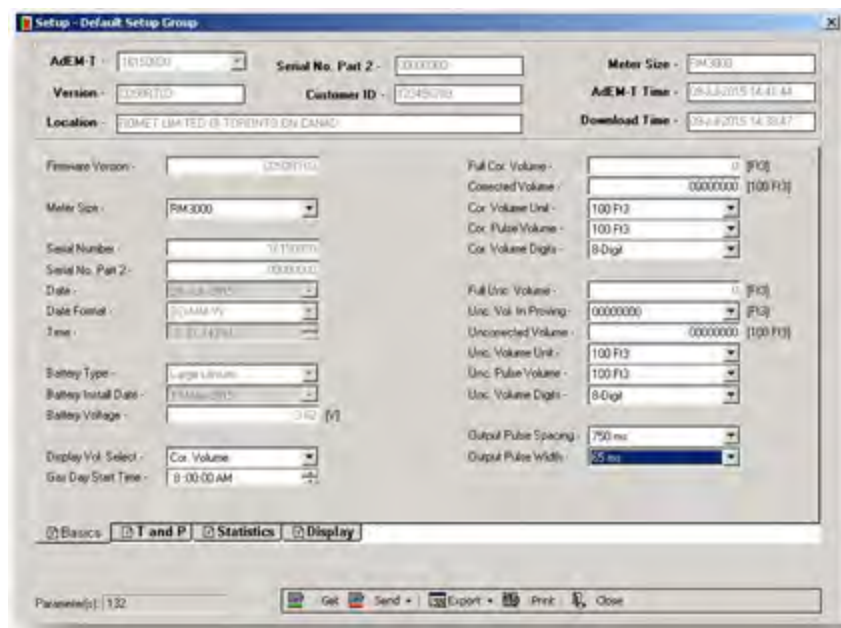

- i. Click **Send** at the bottom of the page.
  - j. Select **Current Page**.
4. Set the ECM2 output pulse spacing to 750 ms for operation with the ERT Module. Output spacing represents an off-time between pulses.

## Wiring instructions

These instructions describe installation with Romet cables and setup options for the AdEM corrector and ECM2<sup>®</sup> meter. These instructions include the two most common setup configurations. For specialized setup instructions, contact Romet.

1. Remove the module backplate (four screws) to expose the module lead wires. The backplate and screws will be re-installed on the module later in this procedure so store them (temporarily) in a safe, secure place.

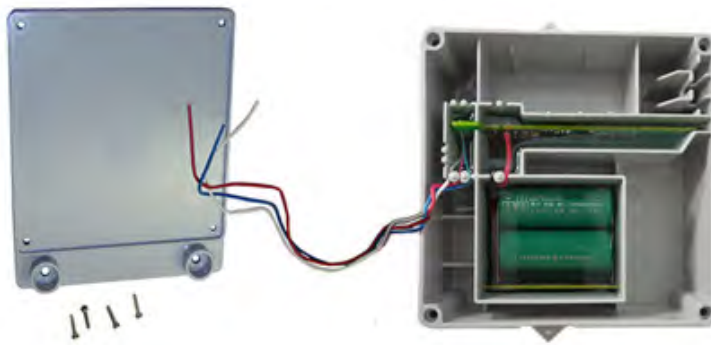

2. Insert the lead wires from the module into new 3M gel connectors (Itron part number CON-0023-001) together with the lead wire from the meter cable (see wiring connections).
3. Crimp the connectors using a 3M hand-held crimping tool.



**Important!** Use a crimping tool compatible with gel-connectors. *Do not* use a standard pliers for crimping gel connectors. For more information, see [Using gel-cap connectors to complete wiring connections on page 163](#).

4. Follow the correct wiring configuration for your Romet corrector or meter from the following wiring parameters.
  - [Standard AdEM Romet 43-035-40 cable wiring on page 138](#)
  - [Romet PG9 Pigtail cable wiring on page 138](#)
  - Romet ECM2 meter wiring

The meter has three Form “A” outputs that can be configured at the factory to provide any combination of the following three outputs:



- Uncorrected volume (UNC VOL)
- Corrected volume (COR VOL)
- Alarm

The pulse weight for the volumetric outputs is configured in *Setup Mode* at **Menu items > SET UNC OUT** and **Menu items > SET COR OUT**. Since Setup Mode is fully configurable, the ECM2 module is universally adaptable to all Romet TC meter bodies. Reference the Romet technical manual for specific details on the ECM2.

- [Rommet cable number 34-125-20 on page 139](#)
- [Rommet cable number 34-125-40 or 34-125-41 on page 139](#)
- [Rommet cable number 34-125-42 on page 139](#)
- [Rommet cable number 34-125-43 on page 140](#)
- [Rommet cable number 34-125-44 on page 140](#)
- [Rommet cable number 34-125-45 on page 140](#)
- [Rommet cable number 34-125-50 on page 141](#)
- [Rommet cable number 34-125-51 on page 141](#)

**Table 14** Standard AdEM Romet 43-035-40 cable wiring

Connection	Corrected count		Uncorrected count	
	Romet cable	ERT Module wire	Romet cable	ERT Module wire
Pulse Output 1+	Green	White	Red	White
		Blue		Blue
Pulse Output 1-	White	Red	Black	Red

**Note:** This wiring configuration will not allow a cut cable tamper.

**Table 15** Romet PG9 Pigtail cable wiring

Connection	Corrected count	
	Romet cable	ERT Module
Pulse Output 1+	White	White
Pulse Output 1-	Red	Red
Cut Cable Alarm	Green	Blue

**Note:** The pigtail cable is the cable extruding from the back of the AdEM corrector. You must select the pigtail cable at the time the AdEM corrector is ordered.

**Table 16** Romet cable number 34-125-20

Cable pin	ERT Module wire		
	Corrected	Uncorrected	Alarm
A	White and blue		
B	Red	Red	
C		White and blue	
D			Red
E			White and blue

**Table 17** Romet cable number 34-125-40 or 34-125-41

Cable pin	ERT Module wire		
	Corrected	Uncorrected	Alarm
A		White and blue	
B		Red	
C	White and blue		
D	Red		
F			Red

**Table 18** Romet cable number 34-125-42

Cable pin	ERT Module wire		
	Corrected	Uncorrected	Alarm
A	White and blue		
B	Red		
C			White and blue
D			Red
F		Red	

**Table 19** Romet cable number 34-125-43

Cable pin	ERT Module wire		
	Corrected	Aux CC	Alarm
A	White and blue		
B	Red		
C		White and blue	
D		Red	
F			Red

**Table 20** Romet cable number 34-125-44

Cable pin	ERT Module wire
	Aux CC
A	
B	
C	White and blue
D	Red
F	

**Table 21** Romet cable number 34-125-45

Cable pin	ERT Module wire		
	Corrected	Uncorrected	Alarm
A		White and blue	
B		Red	
C			White and blue
D	Red		
F			Red

**Table 22** Romet cable number 34-125-50

Cable pin	ERT Module wire		
	Corrected	Uncorrected	Alarm
1		Red	
2	White and blue		
3		White and blue	
4			Red
6			White and blue

**Table 23** Romet cable number 34-125-51

Cable pin	ERT Module wire		
	Corrected	Uncorrected	Aux CC
1		Red	
2	White and blue		
3		White and blue	
4			Red
6			White and blue

5. Install a cable tie to the meter cable just below the exposed colored lead wires on the cable insulation. The cable tie performs as a cable strain relief to mitigate the risk of destructive tension on the lead wires.
6. Remove the excess cable tie using a hand-held side-cutter pliers.



7. Tuck the three gel connectors and cable tie inside the module housing, as shown in the following placement illustration and schematic.

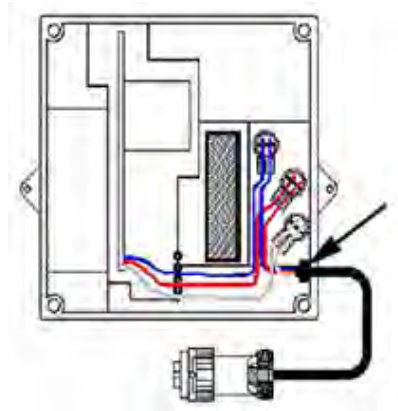
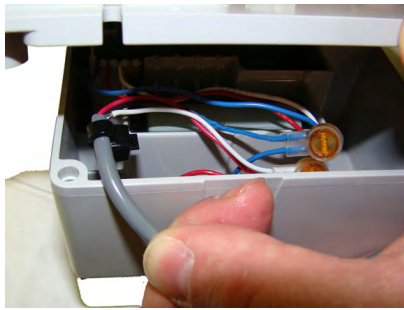

8. Install the remote module backplate using the four screws previously removed from the module and a Torx T-10 screwdriver.



**Important!** Verify that the cable tie and gel connectors are inside the module housing and the cable extends out of the slot in the backplate. Torque the backplate mounting screws to 9 to 12 inch-pounds.

Next, continue to [Programming and verifying on page 147](#).

## Mounting with Romet ECM2 kit

These instructions only apply if you are mounting with a Romet ECM2 kit and assume you have already completed the procedures described in [Programming and verifying on page 147](#). Otherwise, continue to [Mounting a remote-mount module on page 156](#).

**Note:** This mounting option requires a Romet mounting kit. See Romet documentation for custom mounting.



1. Remove the module screw from the back of the ECM2 meter.

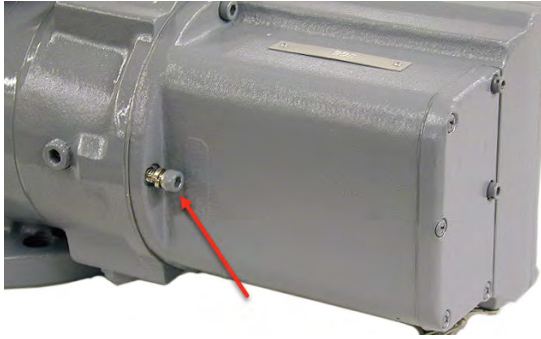

2. Insert the mounting screw fitted with the three lock washers. Two lock washers are used as spacers (as shown).



3. Attach the mounting plate to the meter. Insert the mounting screw where the module screw was removed. Torque the mounting screw to 5-7 foot pounds to secure the plate to the Romet meter.



4. Mount the remote module using the pre-drilled holes on the mounting plate and the module mounting screws.
5. Place new tamper seals over the two screws. Press tamper seals into place using an 11/32-inch nut driver or similar blunt tool.

6. Connect the module to the meter using the previously installed cable interface.



## Sensus meter

Installing the ERT Module to a Sensus meter involves the following tasks:

1. Programming the Sensus meter to work with the ERT Module.
2. Wiring the ERT Module to the meter.
3. Programming the ERT Module.
4. Mounting the ERT Module. Mounting options include:
  - Wall mount on a sheet metal surface
  - Pipe mount
  - Sensus-specific kit

This section provides instructions to install the ERT Module (including part numbers ERG-5006-503, ERG-5600-503, ERG-7600-503, and ERG-7000-503) on compatible Sensus meters. Compatible meters include:

- Sonix pulse output 12, 16, 25, 57 (for metric) and 600, 880, 2000 (for cubic foot)
  - Sonix meters are pulse-output registers that are programmed by Sensus software. Proper pulse-output options and display options must be selected.

## Sensus programming

Using the SonixCom software, configure the Sensus Sonix meter parameters with the following the Sensus pulse output settings.

- One pulse per 10 cubic feet
- One pulse per 100 cubic feet
- One pulse per 1000 cubic feet



## Wiring instructions

Sensus Sonix meters provide a standard Form A electronic pulse output compatible with the ERT Module. You may connect the Sensus Sonix meter to the remote module using the pulse output cable or you can directly mount the ERT Module to the meter.

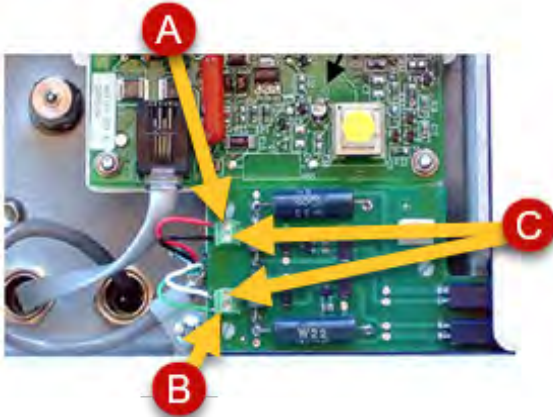

Table 24 and Table 25 describe Sensus meter wiring

**Table 24** Sensus Sonix 2000 meter pulse output options (provides a cut cable when ERT Module wires are cut)

Option	A (pin in image above)	B (pin in image above)	C (pin in image above)
Corrected		White/Blue	Red
Uncorrected	White/Blue		Red

**Table 25** Sensus Sonix 600 or 880 meter wiring (no cut cable or tampers on meter wire)

Meter wire	ERT Module wire
Red	White and blue
Black	Red

For more information about programming wiring parameters, contact Sensus North American Gas Customer Service.

Next, continue to [Programming and verifying on page 147](#).

## Mounting with Sensus-specific kit

These instructions only apply if you are mounting with a Sensus-specific kit and assume you have already completed the procedures described in [Programming and verifying on page 147](#). Otherwise, continue to [Mounting a remote-mount module on page 156](#).

The Sensus factory can direct mount the remote module to Sensus Sonix Meters (contact Sensus North American Gas Customer Service for mounting specifications and ordering

information). This section includes the instructions for customers to mount the module on the Sonix meter using the mounting materials available from Sensus Metering Systems.

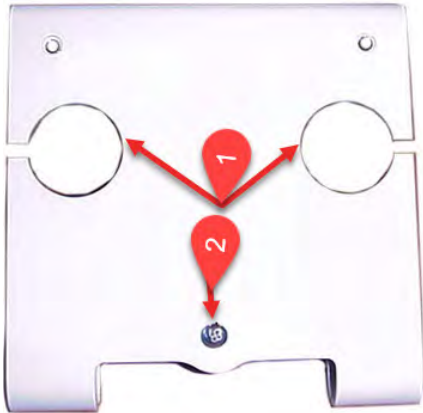

1	Top anchor screw positions
2	Bottom anchor position for the module U-shaped mount

1. Place the module mounting bracket over the inlet or outlet pipe fitting on the Sonix meter. (The default position is over the inlet connection. The inlet connection is the left side connection looking at the front of the meter.)
2. Remove the four ERT Module backplate screws and turn the backplate so the module mounting screw holes are to the top of the module (the arrow on the module label must point up).
3. Secure the module with the four module backplate screws that were previously removed.
4. Slide the mounting lug (now on the bottom of the module) over the bottom anchor.
5. Insert the two top module mounting screws and tighten in an alternating pattern.

# 5

## Programming and verifying

If you installed your ERT Module using the ZTD method in a location with little or no gas flow, rotate the wriggler five times to activate the ERT Module. Then skip to [Verifying operation on page 152](#).

ERT Modules require programming before they can record meter data with accuracy. When you program a ERT Module, you provide it with essential information about the meter, like the meter's configuration, high-flow threshold, and current reading. This information synchronizes the ERT Module with the meter and gives it a base from which to calculate future reads.

Programming Itron modules requires an understanding of:

- Your meter's drive rate and the number of dials
  - The drive rate and number of dials is important for programming the ERT Module to count correctly and roll over to zero at the correct time. For example, a four-dial, two cubic-foot meter configuration counts two cubic-feet for each rotation and rolls over to zero after 9999.99 where the **ones place** is equivalent to 100 cubic-feet.
- How your system interprets the meter reading
  - Some systems modify the consumption reading with the collection software. Other times, the billing system is used to make modifications. If modifications are made in both systems, issues may cause consumption reading errors.

When programming the ERT Module:

- Do not program configuration changes to the ERT Module until it is connected to the gas meter.
- Hold the handheld meter reader as close to vertical as possible.
- For best success, keep the handheld within six feet of the target module.
- Do not place the programming device antenna directly on the ERT Module.

The requirements and procedures for programming vary between meter-reading applications. Note that programming parameters are based on the configuration file loaded into the programming device. Refer to the respective meter-reading application's documentation for specific instructions:

- For FDM, see the [FDM Tools Mobile Application Online Help](#).
- For Field Tools, see the [Field Tools for North American Gas and Water ERTs and Meters Help](#).

To identify whether the ERT Module is in network or mobile mode, issue an Auto detect command.



**Important!** Make sure you have the ability to request commands (if using Field Tools) or retrieve secure commands (if using FDM), described in [Installation prerequisites on page 11](#).

After programming, the ERT Module enters the selected operating mode and begins to bubble up specified messages at the chosen rate.

## Itron programs and software variables

This section defines and clarifies possible system variables you may encounter in programming modules.

### Field Deployment Manager (FDM)

The following tables illustrate various FDM programming configurations and the endpoint response to each setting.

	1,000,000,000,000 CF	100,000,000,000 CF	10,000,000,000 CF	1,000,000,000 CF	100,000,000 CF	10,000,000 CF	1,000,000 CF	100,000 CF	10,000 CF	1,000 CF	100 CF	10 CF	1 CF
3 Dial, 1 cubic foot													1
3 Dial, 2 cubic feet													2
4 Dial, 1 cubic foot													1
4 Dial, 2 cubic feet													2
4 Dial, 5 cubic feet													5
4 Dial, 10 cubic feet												1	
5 Dial, 1 cubic foot													1
5 Dial, 2 cubic feet													2
5 Dial, 5 cubic feet													5
5 Dial, 10 cubic feet												1	
5 Dial, 20 cubic feet												2	
5 Dial, 25 cubic feet												2	5
5 Dial, 40 cubic feet												4	
5 Dial, 50 cubic feet												5	
5 Dial, 100 cubic feet											1		
5 Dial, 500 cubic feet											5		
5 Dial, 1000 cubic feet										1			
6 Dial, 5 cubic feet													5
6 Dial, 10 cubic feet												1	
6 Dial, 20 cubic feet												2	
6 Dial, 50 cubic feet (CCF)												5	
6 Dial, 50 cubic feet (MCF)												5	
6 Dial, 100 cubic feet (CCF)											1		
6 Dial, 100 cubic feet (MCF)											1		
6 Dial, 500 cubic feet (CCF)											5		
6 Dial, 500 cubic feet (MCF)											5		
6 Dial, 1000 cubic feet (CCF)										1			
6 Dial, 1000 cubic feet (MCF)										1			
6 Dial, 10000 cubic feet										1			
7 Dial, 100 cubic feet (CCF)											1		
7 Dial, 100 cubic feet (MCF)											1		
7 Dial, 1000 cubic feet (CCF)										1			
7 Dial, 1000 cubic feet (MCF)										1			

<b>Numbers represent the place and value that will increment per count/pulse</b>
<b>Entered in initial index read</b>
<b>Entered in initial index read but will not increment</b>
<b>Not entered in initial index read but passed on in reading</b>
<b>Not entered in initial index read and will not increment; will always read 0</b>
<b>Internal, incrementing digits not visible or transmitted</b>
<b>Not in SCM or SCM Plus but read out in NIM. Rolls over after 32 bits 4,294,967,295</b>

	100,000,000 M <sup>3</sup>	10,000,000 M <sup>3</sup>	1,000,000 M <sup>3</sup>	100,000 M <sup>3</sup>	10,000 M <sup>3</sup>	1,000 M <sup>3</sup>	100 M <sup>3</sup>	10 M <sup>3</sup>	M <sup>3</sup>	0.1 M <sup>3</sup>	0.01 M <sup>3</sup>
5 Dial, 0.05 cubic meter											5
6 Dial, 0.10 cubic meter											1
6 Dial, 1 cubic meter									1		
6 Dial, 10 cubic meters								1			
6 Dial, 100 cubic meters							1				
7 Dial, 10 cubic meters								1			
7 Dial, 100 cubic meters							1				

### Programming example

Endpoint programmed for six-dial, 1000 cubic feet CCF.

1. Enter the initial index read. For this example, the initial read is 123456 where 6 = 600 cubic feet. After the initial programming, an endpoint read will result in a reading of 1234560 where the least significant digit is in 10's of cubic feet. Since counting is with a drive rate of 1000 cubic feet and the reading is transmitted in 10's of cubic feet, the last two digits of the reading will not change.
2. Program the endpoint to 123456.
3. Read the endpoint. The result should be 1234560 with the zero added to put the reading in 10's of cubic feet.
4. Add one count. The result should be 1234660. Notice that the last two digits of **60** do not change.

	1,000,000,000 CF	100,000,000 CF	10,000,000 CF	1,000,000 CF	100,000 CF	10,000 CF	1,000 CF	100 CF	10 CF
6 Dial, 1000 cubic feet (CCF)							1		

### Mercury X-Blank options

ERT Modules can be programmed with one of the Mercury X-Blank options. There are 1, 2, 3, and 4 blank options available. Blank options are set up as a *what-you-see-is-what-you-get* (WYSIWYG) configuration. The values are not set in cubic feet or cubic meter standards. The Mercury X-Blank options are used in configurations where the system receives pulses from a corrector or instrument that can change pulse values and has configurable display digits. The Mercury-X Blank options allow users to program the endpoint to match the configuration of the corrector or instrument.



## Check Endpoint functions

The FDM Check Endpoint function triggers users to input the number of dials and drive rate if a Check Endpoint is requested for an endpoint programmed for 5-, 6-, or 7-dial meter configurations. The request to input the dial and drive rate information happens only if the system has more than one option using the same count rate and rollover variable enabled in their FDM business unit.

**Note:** Itron recommends that users only enable the configurations used by your business unit. Having only one meter configuration option enabled (with the endpoint variable being checked in the FDM business unit) eliminates the need to enter the number of dials.

## Field Collection System (FCS) (mobile mode only)

Since the Endpoint Translation Code is based on the Read Type Code and the Endpoint Type, changing from a 40-series endpoint to a 100-series endpoint can cause the reading to be truncated differently. If you are having issues with your reading after a change out, check your Read Type Codes and Endpoint Translation Codes.

## OpenWay Collection Manager (OWCM)

The OpenWay Collection Manager (OWCM) collects the raw reading and passes it on without making any formatting changes.

## Field Tools

The programming operation for Field Tools uses the same configurations as FDM Tools. The primary difference is that Field Tools is accessed through a dedicated mobile app built for iOS, Android and Windows 10 devices.

## Standard configuration and battery life

ERT Modules are capable of configurations that reduce battery life. Standard battery life is based on the following configuration:

- Hourly interval data
- Interrogations of three times per day
- 60-second receiver wake up
- Five firmware downloads over the life of the ERT Module
- Network management and security overhead set to default timing
- RF at capacity (2,000 maximum per cell)
- Average of one two-way command/response per week



## Verifying operation

Itron strongly recommends performing a **Check Endpoint** (if using FDM) or **Check** (if using Field Tools) to verify that the ERT Module is operating correctly after installation.

Performing a **Check Endpoint/Check**:

- Initiates an immediate connection to the network and a register read.
- Checks for and indicates event or alarm flags.

Performing a Check Endpoint/Check does not immediately indicate that the ERT Module is connected to the meter and receiving information. Wait 24-72 hours after initial installation to validate the ERT Module's performance on the network.

- If the result is higher than the number programmed in the loaded configuration profile, the ERT Module is counting correctly.
- If the result is not higher than the number programmed in the loaded configuration profile, replace the ERT Module.



**Important!** Signal strength performance data is not reported to Temetra. If you are using Temetra, use Field Tools to verify operations and perform other programming commands.

Use one of the meter-reading applications and devices described in [Installation prerequisites on page 11](#) to verify that the ERT Module is correctly recording consumption data. Make sure you have the ability to request commands (if using Field Tools) or retrieve secure commands (if using FDM), also described in [Installation prerequisites on page 11](#).



**Caution:** Legacy Itron handheld programming devices cannot read the ERT Module .

## Check Endpoint (FDM)

The following figures show the Check Endpoint command in FDM.

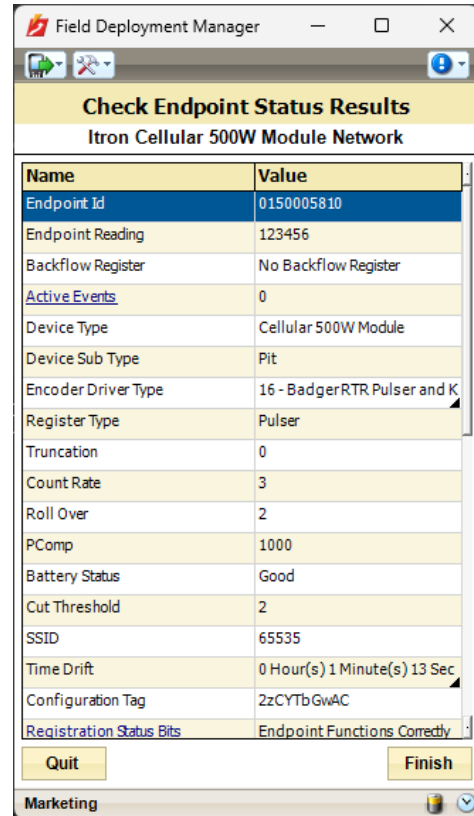
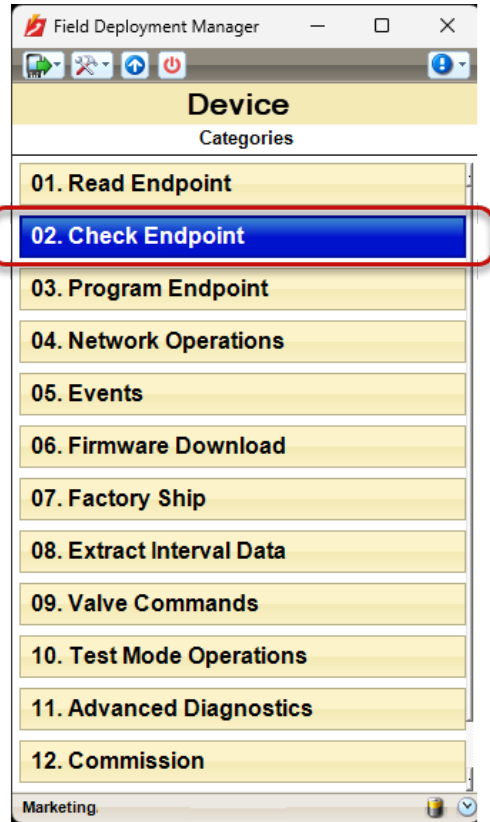

## Check (Field Tools)

The following figures show the Check command in Field Tools.

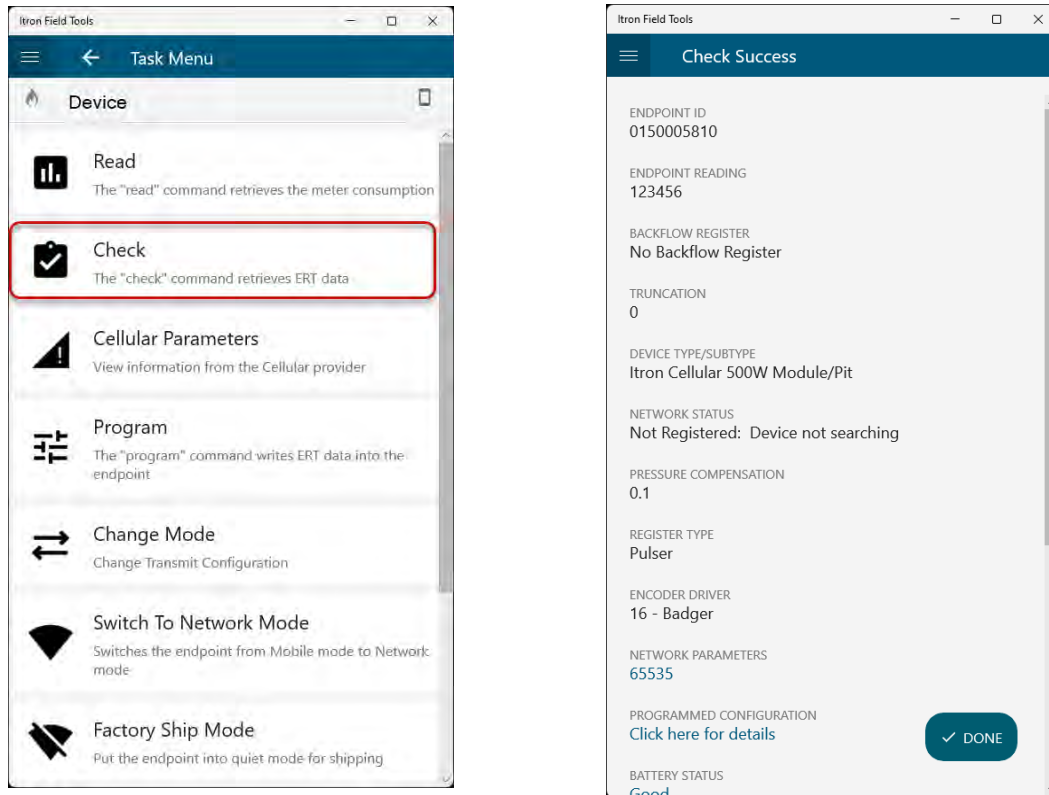

## After programming

If you are performing a direct-mount installation, finish the installation by re-assembling your index:

- Residential meters
  - Reassembling the index on Elster American meters on page 26
  - Reassembling the index on Itron/Sprague meters on page 35
  - Reassembling the index on National meters on page 46
  - Reassembling the index for the Romet rotary meter on page 51
  - Reassembling the index on Sensus/Rockwell meters on page 56
- Commercial meters
  - Reassembling the index on Elster American meters on page 61
  - Reassembling the Dresser index on page 68
  - Reassembling the index on Itron/Sprague meters on page 71
  - Reassembling the index on Romet rotary meters on page 76
  - Reassembling the index on Sensus/Rockwell meters on page 79

If you are performing a remote-mount installation, finish the installation by mounting your module<sup>2</sup>. If you are mounting to a pipe or flat vertical location, see [Mounting a remote-mount module on page 156](#). For custom setups, see the installation instructions for that meter in [Remote-mount installation on page 82](#).

---

<sup>2</sup> This instruction applies to all remote-mount meters except for Dresser meters. Those meters have presumably already been mounted per its instructions.

# 6

## Mounting a remote-mount module

This section is for remote-mount modules only. It assumes you have successfully wired and programmed your module following the instructions in [Remote-mount installation on page 82](#) and [Programming and verifying on page 147](#).

After wiring and programming the ERT Module, it must be mounted. All ERT Module can mount to either a pipe or flat vertical surface (wall). Some ERT Modules can also be mounted with a custom set up designed for the meter it is mounted to. For custom set ups, see the installation instructions for that meter in [Remote-mount installation on page 82](#). Otherwise, see either:

- [Mounting to a pipe on page 157](#)
- [Mounting on a flat vertical location on page 160](#)

### Standard installation options

You can mount the ERT Module with one of the following methods:

- **Pipe mount.** Itron offers a pipe installation kit (CFG-0005-003) to mount the ERT Module on a pipe.
- **Flat vertical (wall) mount.** Installation using the wall mount option places the ERT Module on a wall or other vertical surface.

Select the mounting option that works best for your system. For example, your setup may provide the location for a pipe mount but not a wall mount.

The preferred mounting location is near the meter or instrument, but some installations may require an extended cable length. For example, your installation may require mounting the ERT Module around a corner to avoid RF interference. The ERT Module supports cable lengths up to 300 feet with a recommended one-splice limitation. Installers must mount the ERT Module in a vertical position with the ERT Module label directional arrow pointed upward.



**Warning!** Do not mount the ERT Module in an orientation other than vertical (ERT Module label arrow pointed upward). Violating the mounting orientation requirements may void the product warranty.

Upright vertical positioning is critical because:



- The ERT Modules are optimized for communication and require upright mounting. Any other mounting position could result in reduced RF performance.

- The remote module tilt tamper sensor requires upright mounting. Any other mounting position can cause issues with the module's tilt tamper detection.

## Mounting to a pipe

The items listed in [Table 26](#) are required to mount the ERT Module on a pipe.

**Table 26** Requirements for pipe mount

Itron part number	Description
CFG-0005-003 	Pipe mount kit contents: <ul style="list-style-type: none"> <li>■ Two band clamps</li> <li>■ Two tamper seals</li> <li>■ One pipe bracket</li> <li>■ Two cable ties</li> <li>■ One adapter plate</li> <li>■ The following screws:</li> </ul>  <ol style="list-style-type: none"> <li>1. SCR-0215-001 (2) #8-16 by 0.5 inch slotted pan-head tapping screw, corrosion-resistant steel. Attaches the adapter plate to the pipe bracket.</li> <li>2. SCR-0215-002 (2) #8-16 by 1 inch slotted pan-head tapping screw, corrosion-resistant steel. Attaches the ERT Module to the adapter plate.</li> </ol>

## To install

1. Remove the pipe bracket and clamp from the kit.



2. Push the end of the clamp's band through the holes in the pipe bracket as shown.



- Push the end of the band through the band clamp screw assembly.
  - Turn the band clamp's screw assembly to fit into the pipe bracket opening.
  - Tighten the clamp screw until the band clamp is secure on the pipe.
3. Place the adapter plate on the pipe bracket with the mounting lug at the top. The adapter plate screw bosses fit into the pipe bracket recess.



4. Ensure that the adapter plate is positioned as shown with the mounting lug (1) at the top.
  - Install the adapter plate on the pipe mounting bracket, use the two shortest (0.5 inch) screws from the pipe mount kit.
  - Place the mounting screws into the holes as shown (2).
  - Tighten both screws in an alternating pattern to 9 to 12 inch-pounds torque.

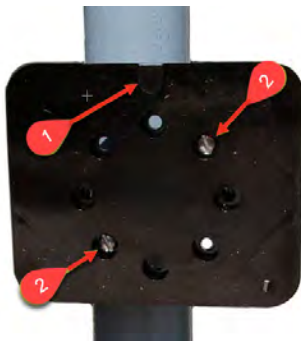

5. Position the back of the ERT Module against the face of the adapter plate. The adapter plate mounting lug must be positioned above the ERT Module mounting lug recess.
6. Push up on the ERT Module until the adapter plate mounting lug is as far as possible inside the ERT Module mounting lug recess.
7. Align the ERT Module back-plate mounting holes with the pipe mount adapter plate holes.
8. Install the two one inch ERT Module mounting screws from the installation kit. Tighten the ERT Module mounting screws evenly in an alternating pattern. Tighten the screws to 9 to 12 inch-pounds torque.





9. Insert the tamper seals.
10. Gather the excess ERT Module cabling into a loop and use the cable tie to secure the gathered cable to the pipe.



## Adapter plate mounting positions

The installation procedure in [Mounting on a flat vertical location on page 160](#) describes how to mount the adapter plate on a vertical pipe. The following pictures show the adapter plate on 45-degree angle and horizontal pipes. Regardless of the angle of the pipe, the adapter plate mounting lug (1) must always be at the top. If the pipe is at a 45-degree angle up to the right, install the adapter plate with the mounting screws (2) as shown.

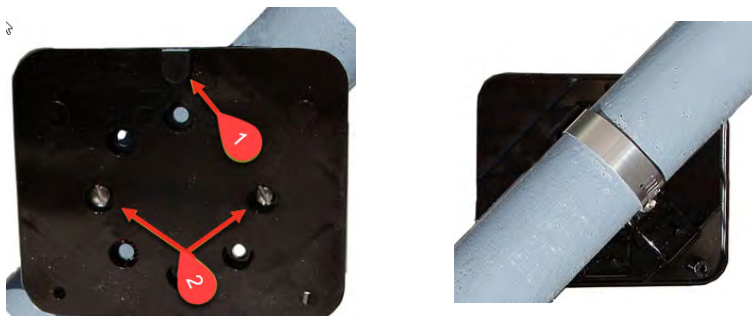

If the pipe is at a 45-degree angle up to the left, install the adapter plate as shown.



If the pipe is horizontal, install the adapter plate as shown.

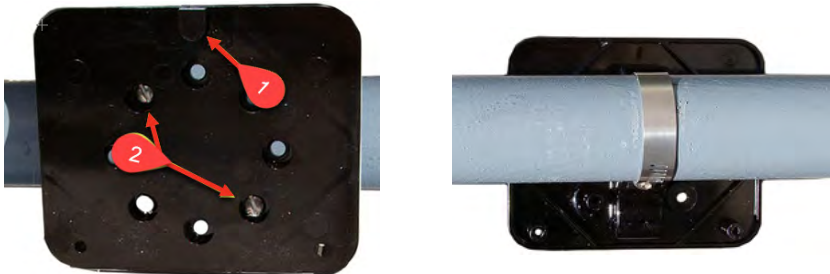

## Mounting on a flat vertical location

Carefully select a mounting location free from electrical wires. The mounting location must have the proper clearance to accommodate the 1.5 inch module mounting screws so nothing is damaged by the drill or mounting screws. Use a compatible mounting screw.

1. Drill three pilot holes in the mounting surface. The drilled pilot holes for the two bottom screws must be on a horizontal line. See the following figure for a reference of distances.
  1. Three inches
  2. 11/16 inch

### 3. 3/8 inch

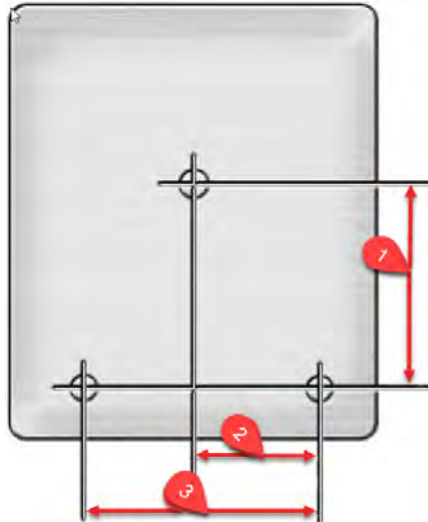

2. Screw the top mounting screw into the top pilot hole drilled in step 1, leaving enough of the screw protruding so the module lug recess on the back plate slides over the screw head and fits completely into the lug recess. Make adjustments as necessary.

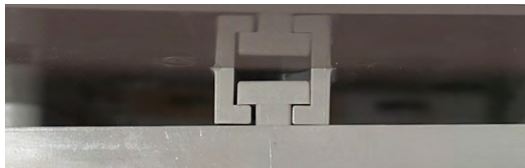

3. Install the two bottom mounting screws. Tighten the screws in an alternating pattern to secure the module firmly in position.
4. Place a new tamper seal over each bottom module mounting screw as required.



To reduce the risk of cable damage, secure any excess module cabling with a cable tie.

**Note:** The device pictured is an OpenWay Riva 500G ERT Module, but these instructions apply to all devices in this guide.



# 7

## Using gel-cap connectors to complete wiring connections

This section provides the instructions to complete remote module to meter wiring connections. Gel-cap connections require:

- E-9R 3M gel-cap crimping tool
  - 3M gel-cap connectors (Itron part number CON-0023-001)
1. Push the two wires into the connector as far as possible.



**Caution:** Do not strip insulation from the ends of the wires before inserting them into the connector.



2. Place the connector and connector wires into the jaws of the crimping tool. Ensure that the wires remain fully inserted in the connector.



3. Squeeze the handles to crimp the connector. Apply pressure until the cap is fully seated (at least three seconds)



4. The connector is properly crimped when the top of the moveable yellow center (1) is flush with the top of the connector body (2).

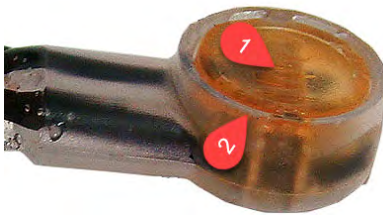

**Caution:** Crimping the connector forces sealant out of the connector. The sealant protects the inside of the connector against insects, moisture, or other contaminants. The sealant may cause minor eye and skin irritation. Avoid eye contact. For more information or Safety Data Sheet (SDS) information, visit the manufacturer website.



# 8

## Optional sealant application instructions

This section applies to remote-mount modules only.

In areas where insect intrusion is a problem (for example, in areas with fire ants that attack the product by crawling inside and eating the potting), Itron recommends an optional sealant to help keep insects out of the module housing. The Itron-tested and approved sealant (part number ADH-5106-000) is used to seal gaps in remote module installations that can allow insect intrusion.



1. Prepare the module for the sealant by verifying the application area is clean and dry.



**Warning!** Apply sealant in a well-ventilated area.

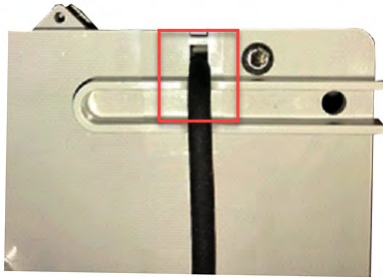

2. Itron recommends sealant application after the remote module is installed so the cable is in the installation position. Use the sealant (ADH-5106-000) to fill the gap.





3. Use enough sealant to fill the gap. Wipe off any excess sealant and replace the cover on the sealant tube.





# Important safety and compliance information

This section provides important information for your safety and product compliance.

## U.S. and Canadian patent numbers

This section describes the patent numbers associated with the products mentioned in this document.

### U.S. patent numbers

- 4,614,945
- 4,753,169
- 4,768,903
- 4,799,059
- 4,867,700

### Canadian patent numbers

- 1,254,949
- 1,267,936
- 1,282,118

## USA, FCC Part 15 spectrum compliance

This device complies with Part 15 of the FCC Rules. These limits are designed to provide reasonable protection against harmful interference in a residential installation.

Operation is subject to the following two conditions:

- This device may not cause harmful interference.
- This device must accept any interference that may cause undesirable operation.

This device must be installed to provide a separation distance of at least 20 centimeters (7.9 inches) from all persons to be compliant with regulatory RF exposure.

### USA, FCC Class B-Part 15

This equipment has been tested and found to comply with the limits for a Class B digital device, pursuant to Part 15 of the FCC Rules. These limits are designed to provide reasonable protection against harmful interference in a residential installation. This

equipment generates, uses, and can radiate radio frequency energy and, if not installed and used in accordance with the instructions, may cause harmful interference to radio communications. However, there is no guarantee that interference will not occur in a particular installation. If this equipment does cause harmful interference to radio or television reception, which can be determined by turning the equipment off and on, the user is encouraged to try to correct the interference by one or more of the following measures:

- Reorient or relocate the receiving antenna.
- Increase the separation between the equipment and receiver.
- Connect the equipment into an outlet on a circuit different from that to which the receiver is connected.
- Consult the dealer or an experienced radio or TV technician for help.

## Modifications and repairs

To ensure system performance, this device and antenna shall not be changed or modified without the express approval of Itron. Per FCC rules, unapproved modifications or operation beyond or in conflict with these instructions for use could void the user's authority to operate the equipment.

## Canada, ISED spectrum compliance

Compliance Statement Canada	Déclaration de Conformité
<p>This device complies with Innovation, Science and Economic Development Canada (ISED) license-exempt RSS standard(s). Operation is subject to the following two conditions: (1) this device may not cause interference, (2) this device must accept any interference, including interference that may cause undesired operation of the device.</p> <p>Under Innovation, Science and Economic Development Canada (ISED) regulations, this radio transmitter may only operate using an antenna of a type and maximum (or lesser) gain approved for the transmitter by Industry Canada. To reduce potential radio interference to other users, the antenna type and its gain should be so chosen that the equivalent isotropically radiated power (e.i.r.p.) is not more than that necessary for successful communication.</p>	<p>Le présent appareil est conforme aux CNR d'Industrie Canada applicables aux appareils radio exempts de licence. L'exploitation est autorisée aux deux conditions suivantes: (1) l'appareil ne doit pas produire de brouillage, (2) l'utilisateur de l'appareil doit accepter tout brouillage radioélectrique subi, même si le brouillage est susceptible d'en compromettre le fonctionnement.</p> <p>Conformément à la réglementation d'Industrie Canada, le présent émetteur radio peut fonctionner avec une antenne d'un type et d'un gain maximal (ou inférieur) approuvé pour l'émetteur par Industrie Canada. Dans le but de réduire les risques de brouillage radioélectrique à l'intention des autres utilisateurs, il faut choisir le type d'antenne et son gain de sorte que la puissance isotrope rayonnée équivalente (p.i.r.e.) ne dépasse pas l'intensité nécessaire à l'établissement d'une communication satisfaisante.</p>

## RF exposure (FCC/ISED)

This equipment complies with radiation exposure limits set forth for an uncontrolled environment. This equipment should be installed and operated with minimum distance 20 cm between the radiator and your body. This transmitter must not be co-located or operating in conjunction with any other antenna or transmitter.

Cet équipement est conforme aux limites d'exposition aux radiations dans un environnement non contrôlé. Cet équipement doit être installé et utilisé à distance minimum de 20 cm entre le radiateur et votre corps. Cet émetteur ne doit pas être co-localisées ou opérant en conjonction avec tout autre antenne ou transmetteur.

## Australia, ACMA spectrum compliance

When this device is sold and shipped to Australia, it is configured and labeled accordingly to be compliant with ACMA Standards for the Radio, EMC and RF Exposure. This includes standard AS/NZS 4268 RF spectrum standard for frequency and power out.

## Transportation classification

The Federal Aviation Administration prohibits operating transmitters and receivers on all commercial aircraft. When powered, the Itron device is considered an operating transmitter and receiver and cannot be shipped by air. All product returns must be shipped by ground transportation.

## Modifications, repairs, installation, and removal

To ensure system performance, this device and antenna shall not be changed or modified without the express approval of Itron. Any unauthorized modification will void the user's authority to operate the equipment.

In the event of malfunction, all repairs should be performed by Itron. It is the responsibility of users requiring service to report the need for service to Itron.

## Lithium battery safety



**Warning!** Follow these procedures to avoid injury to yourself or others:

- The lithium battery may cause fire, explosion, and severe burn hazards if it is not disposed of properly.
- Do not recharge, disassemble, heat above 100° C (212° F), crush, expose to water, or incinerate the lithium battery.
- Keep the lithium battery away from children.

## Equipment repairs



**Warning!** Only authorized Itron personnel should attempt repairs on Itron equipment. Attempts to do so by others might void any maintenance contract with your company. Unauthorized service personnel might also be subject to shock hazard on some Itron equipment if removal of protective covers is attempted.

## Intrinsic safety



**Warning!** Substitution of components may impair intrinsic safety.

## Electrostatic ignition hazard



**Warning!** Verify the area is not hazardous when installing, servicing, cleaning, or touching the Itron device.

## Module cleaning



**Warning!** Clean only with a damp cloth.

## Do not drop



**Warning!** While Itron modules are designed to withstand a drop, dropping the module may damage the device and void the warranty.