



Excellence in Compliance Testing

Certification Exhibit

FCC ID: SK9M2LG2

IC: 864G-M2LG2

FCC Rule Part: 15.247

IC Radio Standards Specification: RSS-247

ACS Project Number: 15-0513

Manufacturer: Itron Electricity Metering, Inc.

Model: M2 Gateway2

Manual

OpenWay® M2 Gateway2

Technical Reference Guide

Effective Date: February 2016

Putting knowledge to work.

Revision History

The following table describes the changes to this document for each revision of the OpenWay M2 Gateway2:

Revision	Date	Description of Change
A	November 2010	Initial Release
B	February 2016	Updated for model M2 Gateway2

DRAFT

Labeling

The following requirements will be applied to any products that use this module:

The end product or host label will include the following text:

- Contains:
- FCC ID: SK9M2LG2
- IC: 864G-M2LG2, Model: M2 Gateway2

The user's manual for any product that contains this module will contain the following text. If the device is large enough, then this will also be placed on the label.

“This device complies with Part 15 of the FCC Rules. Operation is subject to the following two conditions: (1) this device may not cause harmful interference, and (2) this device must accept any interference received, including interference that may cause undesired operation.”

Regulatory Compliance

The user's manual for any product that contains this module will contain the following text:

FCC Part 15, Class B

This equipment has been tested and found to comply with the limits for a Class B digital device, pursuant to Part 15 of the FCC Rules. These limits are designed to provide reasonable protection against harmful interference in a residential installation. This equipment generates uses and can radiate radio frequency energy and, if not installed and used in accordance with the instructions, may cause harmful interference to radio communications. However, there is no guarantee that interference will not occur in a particular installation. If this equipment does cause harmful interference to radio or television reception, which can be determined by turning the equipment off and on, the user is encouraged to try to correct the interference by one or more of the following measures:

- Reorient or relocate the receiving antenna.
- Increase the separation between the equipment and receiver.
- Connect the equipment into an outlet on a circuit different from that to which the receiver is connected.
- Consult the dealer or an experienced radio/TV technician for help.



Changes or modifications to this device not expressly approved by Itron, Inc. could void the user's authority to operate the equipment.

Industry Canada

This Class B digital apparatus meets all requirements of the Canadian Interference Causing Equipment Regulations. Operation is subject to the following two conditions: (1) this device may not cause harmful interference, and (2) this device must accept any interference received, including interference that may cause undesired operation.

Cet appareillage numérique de la classe B répond à la norme Canadienne sur le matériel brouilleur. L'opération est sujette aux deux conditions suivantes: (1) ce dispositif ne peut pas causer d'interférence nocive, et (2) ce dispositif doit accepter n'importe quelle interférence reçue, y compris les interférences pouvant entraîner un fonctionnement indésirable.

Under Industry Canada regulations, this radio transmitter may only operate using an antenna of a type and maximum (or lesser) gain approved for the transmitter by Industry Canada. To reduce potential radio interference to other users, the antenna type and its gain should be so chosen that the equivalent isotropically radiated power (e.i.r.p.) is not more than that necessary for successful communication.

Conformément à la réglementation d'Industrie Canada, le présent émetteur radio peut fonctionner avec une antenne d'un type et d'un gain maximal (ou inférieur) approuvé pour l'émetteur par Industrie Canada. Dans le but de réduire les risques de brouillage radioélectrique à l'intention des autres utilisateurs, il faut choisir le type d'antenne et son gain de sorte que la puissance isotrope rayonnée équivalente (p.i.r.e.) ne dépasse pas l'intensité nécessaire à l'établissement d'une communication satisfaisante.

RF Exposure (FCC/Industry Canada)

“This equipment complies with radiation exposure limits set forth for an uncontrolled environment. This equipment should be installed and operated with minimum distance 20 cm between the radiator and your body. This transmitter must not be co-located or operating in conjunction with any other antenna or transmitter.”

“Cet équipement est conforme aux limites d'exposition aux radiations dans un environnement non contrôlé. Cet équipement doit être installé et utilisé à distance minimum de 20 cm entre le radiateur et votre corps. Cet émetteur ne doit pas être co-localisées ou opérant en conjonction avec tout autre antenne ou transmetteur.”

Miscellaneous

The user's manual for any product that contains this module will contain the following text:

Professional Installation

This module is intended for professional installation by the integrator. The OEM integrator is still responsible for the FCC compliance requirement of the end product, which integrates this module.

Modification and Repairs

To ensure FCC compliance and system performance, this device, antenna and/or coaxial assembly shall not be changed or modified without the express written approval of Itron. Any unauthorized modification will void the user's authority to operate the equipment. **WARNING!** This device contains no user serviceable parts. Attempts to repair this device by unauthorized personnel may subject the person to shock hazard if removal of protective covers is attempted. Unauthorized repair will void the warranty and/or maintenance contract with your company.

General Description

The Itron M2 Gateway2 is an electricity metering module which includes a 902 MHz to 928 MHz transmitter as well as Zigbee transmitter that operates in the 2405 MHz to 2475 MHz band. The module operates on alternating current voltage which is supplied by a host device. The OpenWay M2 Gateway is fully compliant with the ANSI C12.19 and C12.22 standards for transport of register data over a network, providing a secure, open-standards approach to data collection and communications with the meter. In addition, each OpenWay M2 Gateway2 comes factory-equipped with a ZigBee radio chip to provide a built-in communications pathway to the home for data presentation, load control and demand response.

Recycling Information

The product you have purchased contains circuit boards. At the end of the gateway's useful life, under various state and local laws, it may be illegal to dispose of certain components into the municipal waste system. Check with your local solid waste officials for details about recycling options or proper disposal.

About this Manual

This technical reference guide describes the installation of the OpenWay M2 Gateway2 for the Landis+Gyr Focus meter. The Landis+Gyr Focus meter with the Itron OpenWay M2 Gateway2 is one component of the OpenWay System described in the *OpenWay Collection Engine User Guide*. In addition, refer to the *OpenWay Tools User Manual*. Itron urges you to read the entire manual before attempting installation, testing, operation, or maintenance of a meter/gateway pair. The M2 Gateway2 allows the Landis+Gyr Focus meter to operate as part of an Itron OpenWay System.

Physical Description

The OpenWay M2 Gateway2 module consists of the M2 FOCUS Gateway board mated with the Itron Centron Trifecta Comm board to provide OpenWay functionality on the Landis+Gyr FOCUS meter.

Physical Layout of M2 Gateway2 Module in FOCUS Meter

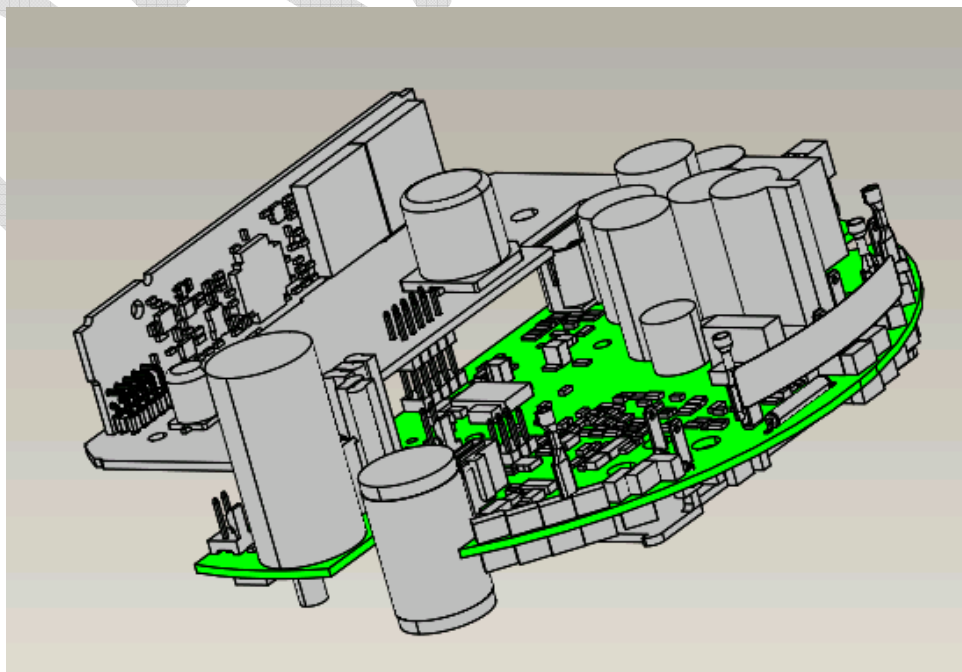
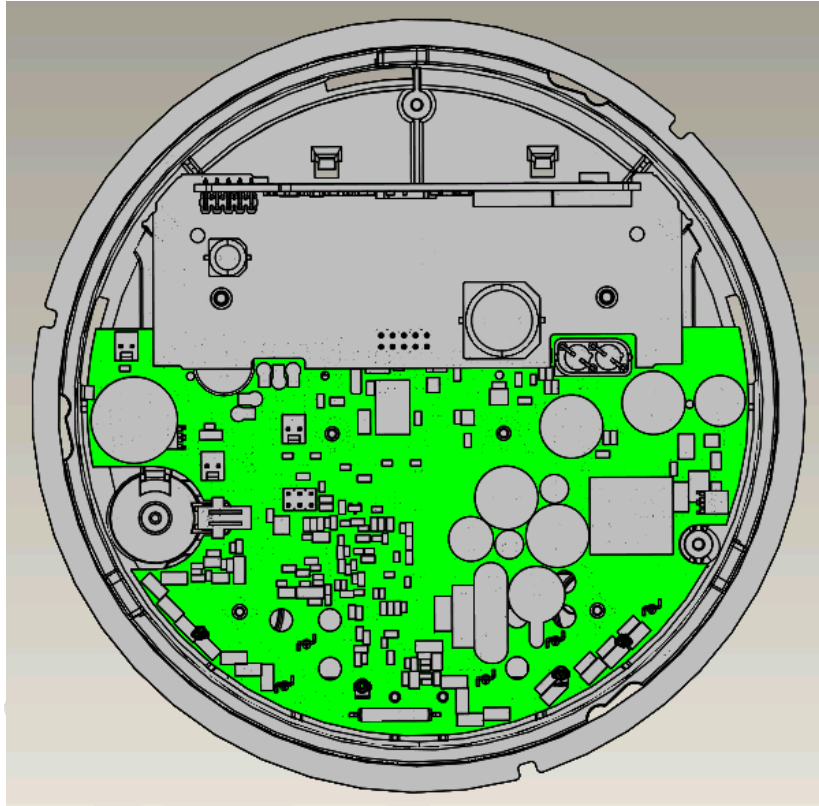

Installation

The M2 Gateway2 module is to be installed in a Landis+Gyr Focus electric meter.

Open the Focus Meter.

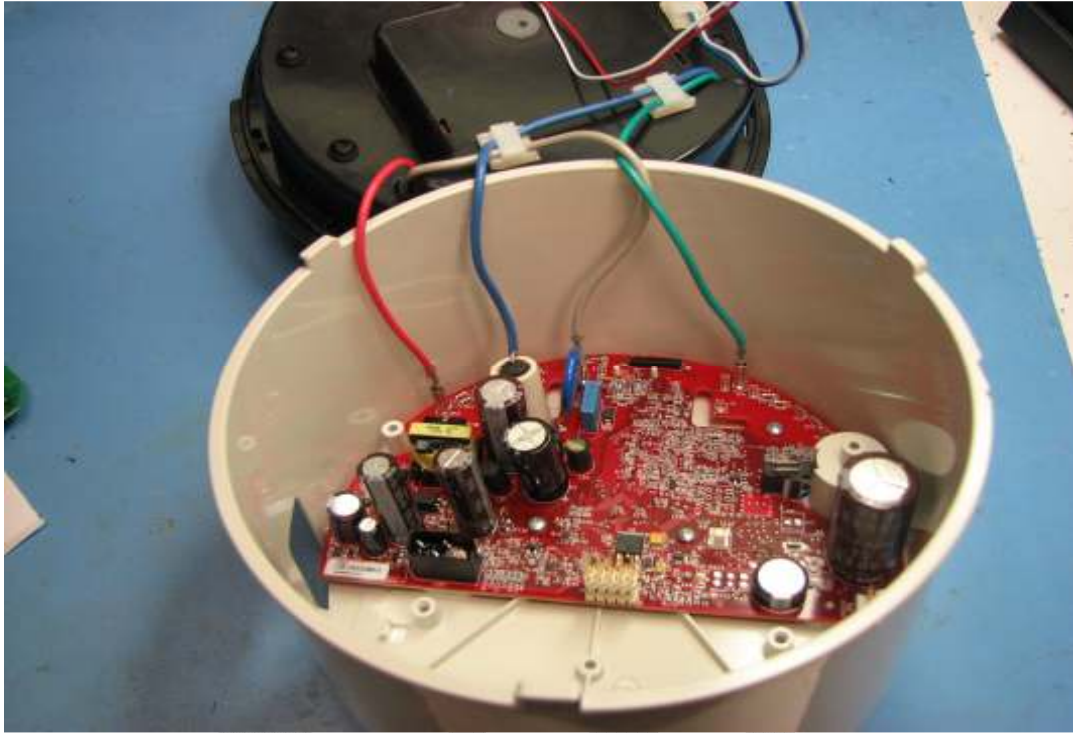

DRAFT

Install the M2 Gateway2.



Tighten the two screws.

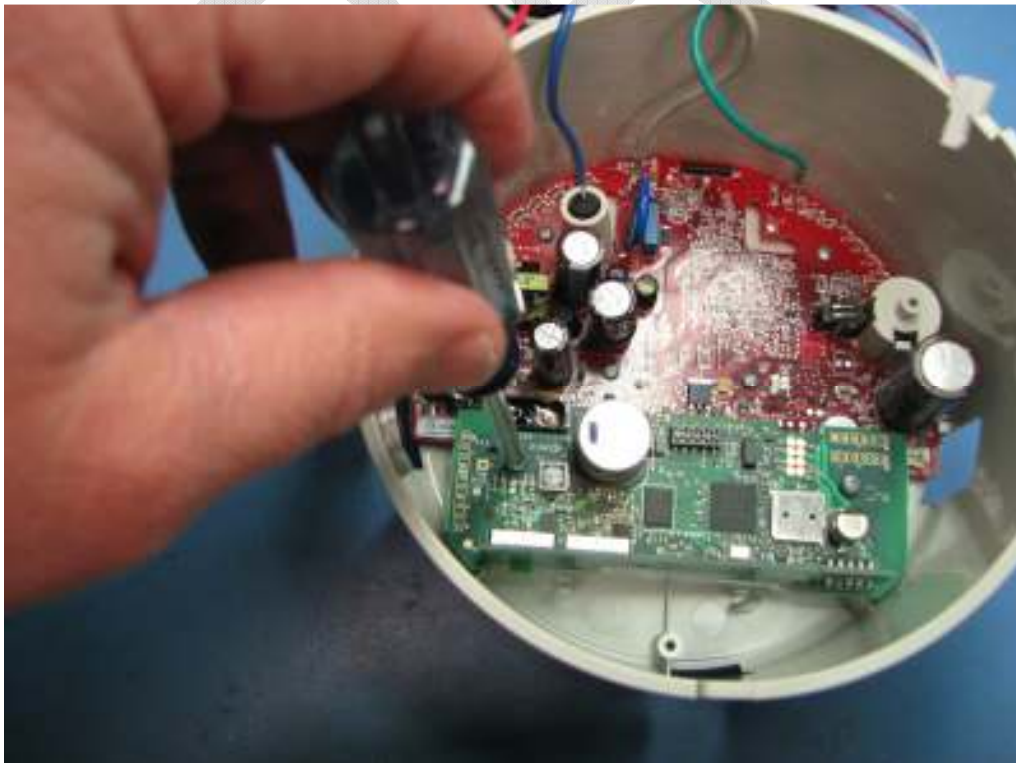

Reattach any power or data cables that are needed, then reattach the two halves of the Focus Meter.



OpenWay System Overview

The OpenWay implementation includes three distinct communication technologies and 2 communication protocols. ANSI C12.22 (also referred to as simply C12.22) is used as the communication protocol from the OpenWay Collection Engine (CE) to the OpenWay L+G Focus/M2 Gateway2 Meter and Web Services are used to communicate from the CE to all upstream applications including Meter Data Management (MDM).