



CODONICS[®]

We bring the future into focus

Safe Label System[®]
SLS 600i
Point of Care Station

User's Manual

Codonics[®] Catalog Number SLS600-MNLU-3.0.0

March 7, 2023

Version 3.0.0 - 030723

Codonics, Inc.

17991 Englewood Drive

Middleburg Heights, OH 44130 USA

440.243.1198 Phone

440.243.1334 Fax

Email info@codonics.com

www.codonics.com

Copyright © 2010 – 2023 by Codonics, Inc. All rights reserved, worldwide. Printed in the USA Part Number XXX-XXX-XXX.

No part of this document may be copied or reproduced in any form by any means without prior written consent of Codonics, Inc., 17991 Englewood Dr., Middleburg Heights, Ohio 44130 USA.

Although every effort has been made to ensure the accuracy of this document, Codonics, Inc. assumes no responsibility for any errors that may appear. Codonics, Inc. makes no commitment to update nor to keep current the information contained in this document.

Patents: www.codonics.com/ip/patents.

Codonics, the Codonics logo, “We bring the future into focus” and Safe Label System are registered trademarks of Codonics, Inc.

Sani-Cloth is a registered trademark of Professional Disposables International, Inc. Windows is a registered trademark of Microsoft Corporation in the United States and/or other countries. iPad is a registered trademark of Apple Inc., registered in the U.S. and other countries. All other registered and unregistered trademarks are the property of their respective owners.



CAUTION Federal law restricts this device to be sold for use by or on the order of a physician.

European Authorized Representative:



CEpartner4U
Esdoornlaan 13,
3951DB Maarn
The Netherlands
www.cepartner4u.com

Contents

Preface

Conventions Used in This Manual.....	xiii
Bulleted Lists.....	xiii
Numbered Steps.....	xiii
Notes.....	xiv
Cautions and Warnings.....	xiv
Important Information and Filenames.....	xiv
Purpose and Scope.....	xv
Product Information.....	xvi
Warnings and Limitations of Use.....	xvii
Location of Safety and Compliance Labels.....	xvii
Voltage Warning.....	xviii
Dangers électriques.....	xix
Laser Warning.....	xx
Danger du Faisceau Laser.....	xx
Serial Number, Configuration, Date Code, and Modification Codes.....	xxi
Potential for Radio Frequency Interference on Device Operation.....	xxii
Potential for Radio and Television Interference.....	xxii
Potential for Operator Exposure to Radio Frequency Energy.....	xxiii
Potentiel d'Exposition de l'Opérateur à l'Énergie des Radiofréquences.....	xxiii
Guidance Regarding Electromagnetic Emissions and Immunity.....	xxiv
Electromagnetic Emissions Standards and Test Levels.....	xxvi
Electromagnetic Immunity Standards and Test Levels.....	xxvi
Safety Precautions.....	xxviii
Précaution d'Emploi.....	xxix

Location Precautions.....	xxx
Environnement de Fonctionnement	xxxix
Cleaning Precautions	xxxix
Précautions d'Entretien	xxxix
Disinfecting Precautions.....	xxxix
Précautions de Désinfection	xxxix
Media Precautions	xxxix
Précautions de Média et Consommables	xxxix
Disposal Requirements	xxxix
Conditions et Règles d'Utilisation.....	xxxix
European Disposal Requirements	xxxix
Indications for Use	xxxvii
Device Description	xxxvii
Device Characteristics	xxxvii
Device Indications for Use Statement: Prescription Use Device.....	xxxix

Chapter 1: Introduction

Welcome and Congratulations	1-1
Product Features	1-2
Hardware Features	1-2
Operational Features	1-3

Chapter 2: Setting Up the System

Finding a Location for the System	2-1
Shipped Components	2-2
Identifying the Components.....	2-5
SLS PCS Front Components	2-5

Components Inside SLS PCS Front Cover	2-7
SLS PCS Rear Components	2-9
SLS PCS Wi-Fi Adapter USB Port	2-10
MAC Address Label Locations	2-11
Touch Screen	2-12
Connecting the Ethernet Cable (Optional)	2-13
Connecting the Wi-Fi Adapter (Optional)	2-15
Connecting the External Power Supply	2-16
Inserting the SmartDrive	2-18
Starting Up the System	2-19
Installing the Ink Cartridge	2-21
Loading or Replacing the Label Media	2-26
End of Media Roll Behavior	2-30
SmartDrive and Stored Information	2-31
Information Stored on the SmartDrive	2-31
Events That Synchronize Data to the SmartDrive	2-32

Chapter 3: Basic Operations

Making a User Badge	3-1
Logging In	3-3
Touch Screen User Interface	3-11
SLS Utilities	3-12
Displaying the Utilities Screen	3-14
Cleaning the Ink Cartridge Nozzles	3-15
Adjusting the Media Path	3-18
Adjusting the Label Black Levels	3-20
Setting Fast Print Mode	3-22
Printing a User Badge	3-23

Calibrating the Printer	3-25
Configuring the Network.....	3-26
Backing Up Log Files	3-27
Clearing Errors	3-30
Adding a Feature.....	3-32
Setting the Date and Time.....	3-35
Adjusting the Touch Screen Brightness	3-37
Adjusting the Audio Volume	3-37
Closing the Utilities screen.....	3-39
Logging Out	3-40
Being Logged Out Automatically Due to Inactivity	3-41
Screen Saver On Due to Inactivity	3-42
Auto-Logout and Screen Saver in Batch or Copy Mode	3-42
Shutting Down or Restarting the System.....	3-43
Shutting Down or Restarting from the Main Screen	3-43
Shutting Down from the Login Prompt	3-44
Powering Off the System	3-45

Chapter 4: Configuring the Network Connection

Static SLS PCS Device Names	4-2
Setting Up Network Hardware	4-3
Configuring an Ethernet Network Connection	4-3
Configuring an Enterprise Wi-Fi Network Connection	4-9
Configuring a Non-Enterprise Wi-Fi Network Connection	4-21
Disabling the Network Connection	4-32
Network Connection Status	4-35
When Network Connection Settings Are Saved.....	4-37

Chapter 5: Printing Labels

Overview.....	5-1
Formulary Database.....	5-1
Container IDs (Outside the USA).....	5-2
Container IDs and Master IDs (USA Only).....	5-2
Matching Container IDs.....	5-2
Mapping Container IDs to Master IDs (USA Only).....	5-3
Verification.....	5-3
Communication of Verification and Drug Not Found (DNF) Events to the SLS Administration Tool .	
5-3	
SLS Drug Preparation Methods	5-4
Notes About TD/TV Preparation Method	5-5
Printing a Syringe Label	5-6
Scanning the Drug Container Barcode	5-7
Selecting from Matching Container IDs.....	5-9
Learning a Drug (USA Only)	5-10
Verifying a Drug.....	5-12
Drug Not Found (DNF) and Other Item Events.....	5-13
Specifying the Dilution and Diluent (Normal Dilution Method).....	5-16
Specifying a Total Dose/Total Volume and Diluent (TD/TV Method)	5-19
Confirming the Syringe Label Before Printing It.....	5-34
Confirming the Printed Syringe Label	5-36
Auxiliary Barcodes for Container IDs	5-38
Printing a Placeholder Graphic for a Non-Compliant Container ID.....	5-39
Manually Entering the Expiration Date/Time on a Syringe Label	5-40
Custom Labels.....	5-40
Custom Label Categories.....	5-40
Blank.....	5-41

Lines	5-42
IV	5-43
Patient.....	5-44
Printing Custom Labels	5-45
Printing Labels in Batch Mode	5-47
Positioning SLS PCS to Support Printing Labels in Batch Mode	5-48
Printing Multiple Labels in Batch Mode	5-48
Reaching the End of Media Before a Batch or Copy Job Completes	5-54
Strip Cut Printing.....	5-54
Single Cut Printing.....	5-55
Printing Labels in Copy Mode.....	5-56
SLS Advanced Smart Scanning	5-61
SASS Use Cases	5-61
SLS Formulary Drug Print Setting Set to Always.....	5-62
SLS Formulary Drug Print Setting Set to Never (e.g., Pre-Filled Syringe)	5-63
SLS Formulary Drug Print Setting Set to Allow (e.g., Pre-Filled Syringe)	5-64
Drug Container Not Found in the SLS Formulary	5-65
Drug Container Not Found in the SLS Formulary but Stocked in the Cart (e.g., Gauze, Syringes)	5-66

Chapter 6: Administer Mode

Drug Is Found in the Formulary, Has Not Expired	6-3
Drug Is Found in the Formulary, Has Expired.....	6-3
Drug Is Found in the Formulary, Requires Concentration Confirmation	6-4
Drug Is Not Found in the Formulary	6-5
Unknown Error Occurs	6-6

Chapter 7: Label Sizes and Template Packs

Label Sizes	7-1
Label Template Packs	7-1
STD-1	7-2
STD-2	7-3
STD-3	7-4
Label Template Properties	7-6
User Initials and User IDs in STD-1, STD-2, and EHR-1 Template Labels	7-8
Additional Label Template Packs	7-9
Label Templates That Support Over-Labeling (RBX-1)	7-9
Middle East and Australia Combination Drug Label Template Packs (ME-S1, ME-1)	7-10
China Label Template Packs (ZH-S1, ZH-1)	7-11
Japan Label Template Packs (JP-S1, JP-1)	7-12
EHR Template Pack (EHR-1, EHR-2)	7-13
EBD Template Pack (EBD-3)	7-13

Chapter 8: Third-Party Product Integration

SLS Wired Hand Scanner	8-1
Connecting the Wired Hand Scanner to SLS PCS	8-2
Testing the Wired Hand Scanner Communication with SLS PCS	8-3
Configuring the Codonics-Approved Scanner for SLS PCS	8-4
Cleaning and Disinfecting the Wired Hand Scanner	8-4
Daily Cleaning and Disinfecting Instructions	8-5
Monthly Deep Cleaning and Disinfecting Instructions	8-5
Common Login/Common Scan	8-6
Plexus TG Anesthesia Touch™	8-7
B.Braun Space Pump	8-8

Printing Patient Information on Labels.....	8-9
Starting a New Patient Case	8-11
Labels That Support Patient Information.....	8-12
How Invalid Patient Information Is Handled	8-13

Chapter 9: Maintenance

Ordering Supplies and Parts	9-1
Cleaning the Enclosure	9-2
Cleaning Precautions	9-3
Disinfecting the Enclosure	9-4
Disinfecting Precautions.....	9-4
Installing Update Packages	9-5
Manually Installing an Update Package	9-6
Remotely Installing Update Packages	9-8
Manually Installing SLS System Software.....	9-9
Removing the Rear Cover	9-12
Swapping Systems	9-13
Preparing the System for Shipping	9-13

Chapter 10: Troubleshooting

Status Indicators	10-1
Displaying System Information	10-2
Status Tab	10-3
Printer Tab	10-4
User Tab	10-5
Network Tab.....	10-6
System Tab	10-7

System Status Messages	10-8
Troubleshooting Common Problems	10-10
Clearing a Label Media Jam	10-24
Clearing a Label Jam in the Front Media Guide.....	10-24
Clearing a Label Jam in the Rear Media Guide	10-26

Appendix A: Hazardous Material Information

Materials of Construction	A-1
Matériaux de Construction	A-2
Manufacturing	A-3
Fabrication	A-3

Appendix B: Specifications

Specifications (English)	B-1
Specifications (French).....	B-3

Preface

Conventions Used in This Manual

Bulleted Lists

Bullets are used to display a list of nonprocedural items. For example:

The following events trigger a synchronization of SLS data to that stored on the SmartDrive:

- Automatically every 15 minutes
- Formulary updates

Numbered Steps

The  icon indicates the beginning of a procedure. The steps in a procedure are numbered. For example:



To install an
ink cartridge

1. Open the front cover.
2. Press the Ink button.

Notes

Notes contain additional information related to a topic or procedure. For example:



NOTE: The system will ensure that a test print is performed at least once a day.

Cautions and Warnings

Cautions alert you to actions or situations that could cause harm to equipment or data. For example:



CAUTION Do not touch the copper area of the cartridge print head.

Warnings alert you to actions or situations that could result in personal injury. For example:



WARNING When the front cover is open, avoid contact with the label cutter.

Important Information and Filenames

Bold type is used for emphasis, user interface object names, and paths or filenames. For example:

- The **Barcode Scanner** scans drug container barcodes for identity and verification.
- Use the controls to correct the date and time, then press the **OK** button.

Purpose and Scope

Refer to this User's Manual for procedures on how to perform Safe Label System (SLS) user operations, including:

- Setting up the hardware and software
- Performing basic functions such as logging in and out, and configuring some system settings (for example, sound volume, brightness)
- Printing and confirming syringe labels
- Checking drug syringes by scanning their barcodes
- Maintaining the system
- Monitoring system status and troubleshooting common problems

Product Information

For technical assistance with SLS Point of Care Station (PCS), call Codonics Technical Support at the following number:

Phone: +1 440.243.1198
Toll Free: 800.444.1198 (USA only)

Technical Support is available 24/7/365. Technical Support is also available online via email and the Codonics web site:

Email: support@codonics.com
Web Sites: www.codonics.com

General product information can also be requested by sending email to:

Email: info@codonics.com

Please include your postal mailing address and telephone number in the email message. Basic product information is returned via email unless otherwise requested.

Warnings and Limitations of Use

Location of Safety and Compliance Labels

Codonics is in compliance with various regulations, details of which are listed in Appendix B.

The SLS PCS safety and compliance label, shown below, is located on the bottom of the device (shown on the following page).

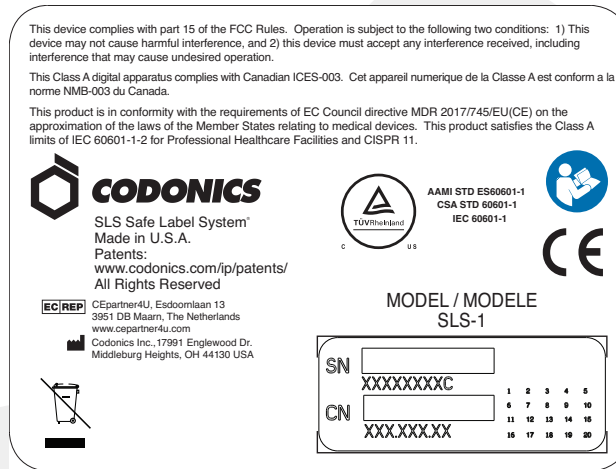

SLS PCS safety and compliance label

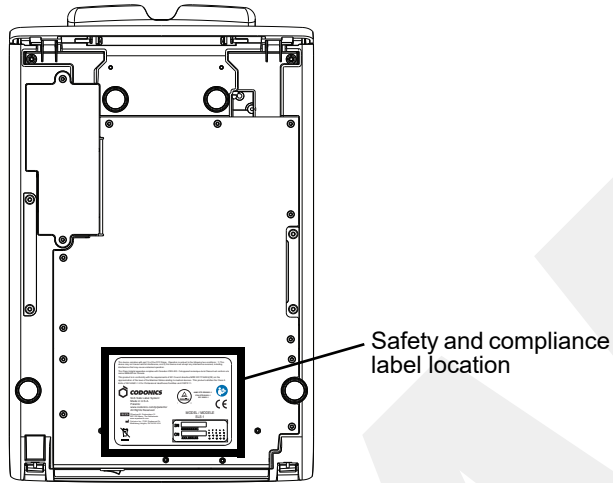

SLS PCS safety and compliance label, on bottom of device

Voltage Warning

The exclamation point within a triangle is intended to alert the user to the presence of important operating and maintenance (servicing) instructions in the literature accompanying this device.



REFER SERVICING TO QUALIFIED SERVICE PERSONNEL. REMOVAL OF LABELS, COVERS, OR ENCASMENT FASTENERS MAY VOID THE WARRANTY.

THIS APPARATUS MUST BE ELECTRICALLY GROUNDED.

TO PREVENT FIRE OR SHOCK HAZARD, DO NOT EXPOSE THIS DEVICE TO RAIN OR MOISTURE.

EQUIPMENT IS NOT TO BE USED AS A COMPONENT OF A LIFE SUPPORT SYSTEM. Life support devices or systems are devices or systems that support or sustain life, and whose failure to perform can be reasonably expected to result in a significant injury or death to a person. A critical component is any component of a life support device or system whose failure to perform can be reasonably expected to cause the failure of the life support device or system, or to affect its safety or effectiveness.



WARNING Grounding reliability can be achieved only when SLS PCS is connected to a receptacle marked “Hospital Only” (that is, “Hospital Grade”).



WARNING The power cord connected to SLS PCS is the main disconnect for the system.



WARNING To disconnect overall power to SLS PCS prior to servicing it, power off the system (refer to “Powering Off the System” on page 3-45).

Dangers Électriques

Le point d'exclamation situé à l'intérieur d'un triangle représente un point d'instruction important dans l'utilisation ou l'entretien de cette appareil.



POUR SOUTIEN ADRESSEZ-VOUS AU PERSONNEL QUALIFIE. LE RETRAIT DE LES ETIQUETTES, LES COUVERTURES, OU LES ATTACHES PEUT ANNULENT LA GARANTIE. CET APPAREIL DOIT ETRE ELECTRIQUEMENT RELIE A LA TERRE.

N'EXPOSEZ PAS CET APPAREIL À LA PLUIE OU L'HUMIDITÉ, EN RAISON DU RISQUE DE FEU OU DE DÉCHARGES ÉLECTRIQUES.

Cet appareil ne doit pas être utilisé comme composant d'un système d'assistance vitale. Les devis ou les systèmes vitale sont quelque devis ou système qui assistent ou soutiennent la vie, et si les devis ou systèmes échouent, on peut attend raisonnablement la mort ou la blessure. Cet appareil ne doit pas être utilisé dans des conditions où la défaillance de l'appareil pourrait entraîner la blessure ou la mort de quelqu'un.



ATTENTION Une mise à la terre fiable est possible seulement pendant que le SLS PCS est connecté aux appareils marqué "Hospital Only" (de qualité hospitalière).



ATTENTION Le fil électrique connecté à le SLS PCS sont le système de coupure principal de l'appareil.



ATTENTION Pour débrancher le fil électrique avant le soutien, se déconnecter et puis éteint le système (renvoyer à « Powering Off the System » sur la page 3-45).

Laser Warning



WARNING This device emits CDRH/IEC Class 2 laser and IEC Class 1M light. Do not stare into beam.

Danger du Faisceau Laser



ATTENTION Cet appareil émet un laser CDRH / CEI de classe 2 et une lumière de classe 1M IEC. Ne pas fixer le faisceau.

Serial Number, Configuration, Date Code, and Modification Codes

The serial number label is placed onto the safety and compliance label.

The serial number label includes the following information:

- The serial number (SN), which uniquely identifies the unit.
- The configuration number (CN), which details the build configuration.
- The modifications codes, which are to the right of the CN number and are a series of 20 numbers. When any of these numbers are blocked out, that identifies a modification that was made to the unit.

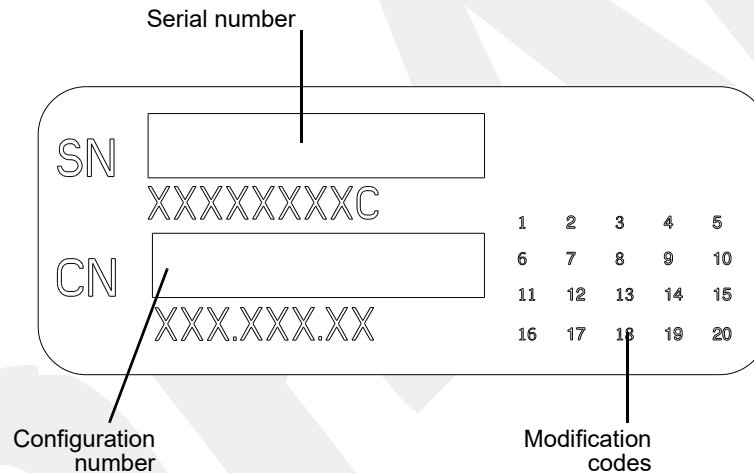

Serial number label

Potential for Radio Frequency Interference on Device Operation

Both portable and mobile RF communications equipment can affect medical electrical equipment, including SLS PCS. SLS PCS is intended for use in the electromagnetic environment specified in the guidance and manufacturer's declaration section.

Potential for Radio and Television Interference

SLS PCS generates and uses radio frequency energy, and if not installed and used properly, that is, in strict accordance with the manufacturer's instructions, may cause interference to radio and television reception. This device complies with part 15 of the FCC Rules. Operation is subject to the following two conditions: (1) This device may not cause harmful interference, and (2) this device must accept any interference received, including interference that may cause undesired operation. SLS PCS is not intended for use in a residential Class A environment. SLS PCS requires a medical power/ground. If your SLS does cause interference to radio or television reception, you are encouraged to try to correct the interference by one or more of the following measures:

- Reorient the receiving antenna
- Relocate SLS PCS with respect to the receiver

If necessary, you should consult Codonics Technical Support or an experienced radio/television technician for additional suggestions. You may find the following booklet prepared by the Federal Communications Commission helpful: *How to Identify and Resolve Radio-TV Interference Problems*. This booklet is available from the U.S. Government Printing Office, Washington, D.C. 20402, Stock No. 004-000-00345-4.

Le présent appareil numérique n'émet pas de bruits radio-électriques dépassant les limites applicables aux appareils numériques de la Classe B prescrites dans le Règlement sur le brouillage radioélectrique édicté par le ministère des Communications du Canada.

This product is in conformity with the protection requirements of EC Council directive MDR 2017/745/EU(CE) on the approximation of the laws of the Member States relating to medical devices. This product satisfies the Class A limits of IEC 60601-1-2 for Professional Healthcare Facilities and CISPR 11. A declaration of conformity with the requirements of the Directive has been signed by a Codonics vice president.

Potential for Operator Exposure to Radio Frequency Energy

The Safe Label System, when equipped, emits radio frequency energy for the purpose of reading and writing to radio frequency identification (RFID) tags. The device transmits momentarily after scanning a drug barcode at the front cover and also when printing labels equipped with RFID functionality. The radio transmitters are disabled at all other times. The Safe Label System meets the radio frequency exposure requirements of the U.S. 47CFR 1.1310 and Canada RSS-102 standards. The time-averaged power of emitted radio energy is well below the SAR exemption thresholds for human exposure set forth by the United States and Canada.

Potentiel d'Exposition de l'Opérateur à l'Énergie des Radiofréquences

Le Safe Label System, lorsqu'il est équipé, émet de l'énergie radiofréquence dans le but de lire et d'écrire sur des étiquettes d'identification par radiofréquence (RFID). L'appareil transmet momentanément après avoir scanné un code-barres de médicament sur l'étiquette avant et également lors de l'impression d'étiquettes équipées de la fonctionnalité RFID. Les émetteurs radio sont désactivés à tout autre moment. Le Safe Label System répond aux exigences d'exposition aux radiofréquences des normes U.S. 47CFR 1.1310 et Canada RSS-102. La puissance moyenne dans le temps de l'énergie radio émise est bien inférieure aux seuils d'exemption SAR pour l'exposition humaine établis par les États-Unis et le Canada.

Guidance Regarding Electromagnetic Emissions and Immunity

Suitable environments are as follows:

- SLS600i is intended for use in hospital and clinical environments including operating rooms and the perioperative environment.
- SLS600i has not been evaluated for use near HF surgical equipment. If use near HF surgical equipment is desired, the user is responsible for verifying proper operation of the SLS600i. If SLS600i does not perform correctly in this environment, move the SLS600i farther from the source of the electromagnetic disturbance.
- SLS600i has not been evaluated for use in emergency medical vehicles or in residential applications.



NOTE: *The radio frequency emissions characteristics of this equipment make it suitable for use in industrial areas and hospitals (CISPR 11 class A). If it is used in a residential environment (for which CISPR 11 class B is normally required) this equipment might not offer adequate protection to radio-frequency communication services. The user might need to take mitigation measures, such as relocating or re-orienting the equipment.*

As a support device, SLS600i does not provide essential performance.



WARNING Use of this equipment adjacent to or stacked with other equipment should be avoided because it could result in improper operation. If such use is necessary, this equipment and the other equipment should be observed to verify that they are operating normally.



WARNING Use of accessories, transducers and cables other than those specified or provided by the manufacturer of this equipment could result in increased electromagnetic emissions or decreased electromagnetic immunity of this equipment and result in improper operation.



WARNING Portable RF communications equipment (including peripherals such as antenna cables and external antennas) should be used no closer than 30 cm (12 inches) to any part of the SLS600i, its cables, or accessories. Otherwise, degradation of the performance of this equipment could result.



ATTENTION The Safe Label System contains authorized radio equipment that has been tested and approved as a system. Changes or modifications to the Safe Label System that are not expressly approved by Codonics could void the user's authority to operate this equipment in the field.

DRAFT

Electromagnetic Emissions Standards and Test Levels

Test/Standard	Compliance
RF Emissions CISPR 11	Group 1. Class A
RF Emissions FCC Part 15	Class A
Conducted Emissions CISPR 11	Group 1. Class A
Harmonic Distortion IEC 61000-3-2	Class A
Voltage Fluctuations and Flicker IEC 61000-3-3	Complies

Electromagnetic Immunity Standards and Test Levels

Test/Standard	Compliance
Electrostatic Discharge IEC 61000-4-2	+8 kV contact +2 kV, +4 kV, +8 kV, +-15 kV air
Radiated RF Immunity IEC 61000-4-3	3 V/m 80 MHz – 2.7 GHz 80% AM at 1 kHz
Proximity fields from RF wireless equipment IEC 61000-4-3	Complies

Test/Standard	Compliance
Electrical Fast Transient/Burst	AC Port: ± 2 kV, 100 kHz repetition frequency
IEC 61000-4-4	SIP/SOP Ports: ± 1 kV, 100 kHz repetition frequency
Surge	Line-to-Line: ± 0.5 kV, ± 1.0 kV
IEC 61000-4-5	Line-to-Ground: ± 0.5 kV, ± 1.0 kV, ± 2.0 kV
Conducted Immunity	AC Port and SIP/SOPs:
IEC 61000-4-6	3 V, 0.15 MHz – 80 MHz
	6 V, in ISM bands between 0.15 MHz and 80 MHz
	80% AM at 1 kHz
Magnetic Field Immunity	30 A/m, 50 Hz or 60 Hz
IEC 61000-4-8	
Voltage Dips	0% UT, 0.5 cycle at 0°, 45°, 90°, 135°, 180°, 225°, 270° and 315°
IEC 61000-4-11	0% UT, 1 cycle AND 70% UT, 25/30 cycles, Single phase: at 0°
Voltage Interruptions	0% UT, 250/300 cycle
IEC 61000-4-11	
Radiated fields in close proximity	134.2 kHz: 2.1-kHz pulse modulation, 65 A/m
IEC 61000-4-39	13.56 MHz: 50-kHz pulse modulation, 7.5 A/m
Exposure to Radio Frequency ID Readers	Table 3 test levels
AIM 7351731	

Safety Precautions

- Never connect the device's external power supply to any outlet or power supply that has a voltage or frequency different than that specified (100 – 240 VAC, 50/60 Hz).
- Use only the external power supply provided with the device (Codonics part number SLS-PS).
- When replacing the device, always power it down (refer to “Powering Off the System” on page 3-45) and disconnect the AC power cord prior to servicing it.
- Damage to a power cord is a fire and shock hazard. When unplugging a power cord, hold it by the plug only and remove the plug carefully.
- If a power cord or external power supply needs to be replaced, replace it only with another Codonics power cord or Codonics external power supply. Alternatively, replace it with a power cord or external power supply manufactured specifically for your power configuration.
- If the device is smoking or making unusual sounds, power off and unplug the device immediately.
- Do not insert foreign objects of any kind into the device; doing so can constitute a safety hazard and cause extensive damage.
- Do not place any liquid containers on the device. If, for some reason, liquid seeps into the device, power off the device and unplug the power cord from the source outlet. If used without taking corrective measures, the device may be damaged.
- Do not expose the device to flammable gases in concentrations high enough to cause fire or explosion.

Précaution d'Emploi

- *Ne jamais brancher cet appareil sur une source d'alimentation électrique dont la tension ou la fréquence diffèrent des valeurs indiquées (100 – 240 VAC, 50/60 Hz).*
- *Utiliser uniquement l'alimentation électrique fourni avec l'appareil (numero de pièce Codonics SLS-PS).*
- *Avant de remplacer le appareil, veuillez à toujours éteindre l'appareil et n'oubliez pas de débrancher le câble secteur.*
- *Un fil électrique endommagé est une cause d'incendie ou de décharge électrique. En déconnectant le fil électrique, tenez-le seulement par la prise et retirez la prise soigneusement.*
- *Si le fil électrique ou l'alimentation électrique doit être remplacé, utilisez un fil électrique ou un alimentation électrique Codonics fabriqué spécifiquement pour votre appareil.*
- *Si l'appareil fume ou émet des bruits inhabituels arrêtez-le immédiatement et débranchez le fil électrique.*
- *N'introduisez aucun objet étranger dans l'appareil, cela peut être une source de danger et peut causer de graves dommages.*
- *Ne déposez aucun récipient à coté de l'appareil. Si pour quelque raison un liquide filtre à l'intérieur, arrêtez immédiatement l'appareil et débranchez le fil électrique. Toute nouvelle utilisation de l'appareil sans intervention peut causer de graves dommages.*
- *Ne pas utiliser l'appareil à coté d'une source de gaz inflammable.*

Location Precautions

- The operating ambient temperature range of SLS PCS is 15–30°C (59–86°F), with a relative humidity of 20%–80%.
- If SLS PCS is moved quickly from an extremely cold location to a warmer one, condensation is likely to form. Do not use SLS PCS if condensation has formed. Wait until the condensation has evaporated. You can speed up the evaporation time by moving SLS PCS to a dryer location.
- Do not place SLS PCS in a location with high humidity or high dust. Airborne dirt particles can cause print quality problems. Avoid placing SLS PCS in locations where ventilation ducts, open doors, or frequent passers-by might expose SLS PCS and labels to high levels of debris.
- Do not locate SLS PCS in hot-springs areas where hydrogen sulfide and acidic ions are likely to be generated.
- Do not locate SLS PCS where there are oily fumes and vapors.
- Do not locate SLS PCS in direct sunlight.
- Do not locate SLS PCS near sources of high RF energy.
- Do not locate SLS PCS where it might be subject to jarring or vibrations, such as a table or desk in a high-traffic area. Jarring and vibrations can affect the print quality of labels.
- If using a VESA mount to mount the device on a wall, stand, or anesthesia supply cart, refer to the VESA Mounting Interface Standard (MIS), available at www.vesa.org, for proper location and installation information.

Environnement de Fonctionnement

- *Les conditions normales d'utilisation de l'appareil sont : une température de 15 à 30°C et une humidité relative de 20 % à 80 %.*
- *En cas de variation rapide de la température, de la condensation peut se former. En ce cas la n'utilisez pas l'appareil, attendez que la condensation se soit évaporée. Vous pouvez accélère cette évaporation en déplaçant l'appareil dans un endroit sec.*
- *Toujours placez l'appareil dans une zone propre et non-humide. Des particules de poussières peuvent causer des dysfonctionnements de la qualité d'imprimante. Évitez de placer l'appareil à proximité d'une bouche de ventilation, d'une porte, ou d'un endroit très fréquenté car cela pourrait exposer l'appareil ainsi que les étiquettes à la poussière.*
- *Ne placez pas l'appareil à proximité d'une source de chaleur ou de substances acides.*
- *Ne placez pas l'appareil dans une endroit où il y a des vapeurs huileuses et grasses.*
- *N'exposez pas l'appareil à la lumière directe du soleil.*
- *Ne placez pas l'appareil près d'une source haute fréquence.*
- *Ne placez pas l'appareil dans un lieu où il pourrait être exposé à des vibrations, car cela peut nuire l'impression des média.*
- *Si vous utilisez un bras de montage VESA pour monter l'appareil sur un mur, une potence ou un charriot d'anesthésie, veuillez vous référer aux instructions de montage VESA (MIS) sur www.vesa.org pour de plus amples informations.*

Cleaning Precautions

To avoid damage to the device, observe the following general precautions for cleaning the device:

- Apply the cleaner to a clean, lint-free cloth first and then clean the device. Liquid applied directly to the device could possibly leak inside the device and cause damage. Use extra caution when cleaning around the vents on the back of the touch screen and speaker.
- Allow the device to completely dry before operating it again.
- Many plastic components are used in SLS PCS construction. Coat flecking and deformation is likely to occur if the device is wiped with chemical dusters, benzene, thinners, insecticides, or other solvents. Rubber and PVC materials left in contact with SLS PCS for extended periods of time will cause damage. Never use petroleum-based solutions or abrasive cleansers.
- Never use abrasive material.
- Always dilute cleaning agents according to the manufacturer's instructions, or use the lowest possible concentration.
- Do not allow the cleaning agent to remain on the device surfaces. Wipe it off immediately with a lint-free cloth moistened with water.

For cleaning instructions, refer to “Cleaning the Enclosure” on page 9-2.

Précautions d'Entretien

- *Pour éviter les dommages à l'appareil, regardez les précautions d'entretien:*
- *Appliquez le nettoyeur sur un tissu propre et puis nettoyez l'appareil. Liquide qui est appliqué directement sur le appareil peut causer les dommages. Utilisez beaucoup de précautions sur le conduit d'aération en bas de la écran et l'haut-parleur.*
- *L'appareil doit sécher complètement avant marcher encore.*
- *Il y a beaucoup des choses plastiques utilisant avec la fabrication du SLS PCS. L'emploi des chiffons chimiques, de benzène, des diluants, des insecticides, ou des autres solvants peuvent causer les dommages à l'extérieur ou les déformations. Le caoutchouc ou le PVC qui ont beaucoup de contact avec le SLS PCS causeront les dommages. N'utilisez jamais les nettoyeuses avec pétrole ou les nettoyeuses abrasives.*
- *N'utilisez jamais les matérielles abrasive.*
- *Toujours dilatez les nettoyeuses par les instructions du fabricant ou utilisez la concentration le plus faible.*
- *Ne laissez pas les nettoyeuses à la surface de l'appareil pour longtemps. Donnez un coup d'éponge propre.*

Pour instructions d'entretien, regardez « Cleaning the Enclosure » sur la page 9-2.

Disinfecting Precautions

To avoid damage to the device, observe the following general precautions for disinfecting the device:

- Do not use Povodine, Sagrotan, or Mucocit disinfecting agents or strong solvents (for example, acetone).
- Do not use any disinfecting agents that corrode or damage polycarbonate.

Précautions de Désinfection

- *Pour éviter les dommages à l'appareil, regardez les précautions de désinfection.*
- *N'utilisez pas de Provoidine, du Sagrotan, ou de Mucocit désinfectant ou les solvants fortes*
- *N'utilisez pas les désinfectants qui corrodent le polycarbonate.*

Media Precautions

- Unwanted labels should be destroyed or disposed of to ensure that improper labels are not used.
- Only use Codonics ink cartridges and labels to ensure proper operation of the device and proper labeling of syringes. Using unapproved ink cartridges and labels could lead to unacceptable results, including poor print quality and poor label adhesion to syringes.
- Damage from unapproved ink or labels will void the warranty.
- Never refill ink cartridges, as this can result in incorrect color usage.

Précautions de Média et Consommables

- *Les étiquettes inutilisées doivent être disposées ou détruites donc les étiquettes mauvaises ne sont pas à utiliser.*
- *Utilisez seulement les cartouches et étiquettes Codonics pour faire certain que le SLS PCS fonctionne comme il faut.*
- *Tous les dommages causés par l'utilisation de cartouches d'encre ou d'étiquettes non approuvées annuleront la garantie.*
- *Né rechargez jamais les cartouches. Ça peut avoir pour résultat des couleurs incorrectes.*

Disposal Requirements

Disposal of this product and consumables shall be in accordance with all applicable laws and regulations in effect at the locality at the time of disposal. For additional information, refer to Appendix A, Hazardous Material Information.

Conditions et Règles d'Utilisation

L'utilisation de ce produit doit être conforme à toutes les lois et règlements applicables sur le lieu d'utilisation.

European Disposal Requirements

Codonics imagers and electronic accessory devices are not to be discarded or recycled; rather they are to be returned to the manufacturer. Contact Codonics directly or by the link provided for the latest information concerning:

- Identification of the country-specific Importer/Distributor/Producer
- Product return and treatment of our electronic products

Manufacturer: Codonics Inc.
17991 Englewood Drive
Middleburg Heights, OH 44130 USA
Phone: +1 440.243.1198
Fax: +1 440.243.1334
E-mail: WEEE@codonics.com
www.codonics.com

Codonics electronic products and accessories bearing the following symbol are subject to European Directive on Waste Electrical and Electronic Equipment (WEEE) 2002/96/EC, amended by Directive 2003/108/EC. The EN 50419 symbol indicates separate collection and return required.



EN 50419 symbol

Indications for Use

Device Description

Drug preparation and administration in the perioperative environment are integral aspects of anesthesiologist's patient care responsibilities. The Codonics Safe Label System (SLS) is a simple, integrated system utilizing a barcode scanner to read and confirm drug identity from FDA NDC (National Drug Code) and other drug ID Barcodes from drug containers and automatically print labels for prepared drugs and other items in use on patients during surgical procedures. The labels are compliant with national regulations focused on improving medication safety in the perioperative environment.

The software components provide functions for scanning container barcodes; creating, reviewing, and approving the hospital-managed promotion of a formulary database; displaying on-screen and audibly confirming drug type; and printing ISO, ASTM, and TJC (The Joint Commission) content- and color-compliant labels with 1D and/or 2D barcodes. The system reads drug container barcodes and produces water resistant, color labels. The system can be integrated to function with an Anesthesia Information Management System (AIMS) workflow to provide real-time documentation of drug administration when the syringe 1D or 2D barcode is read. The system can be accessed and managed via a network (Ethernet or Wi-Fi).

Device Characteristics

The use of drug class specific pattern and color per ASTM D4774 and ISO 28625 Specifications for User Applied Drug Labels in Anesthesiology is configurable by site and dataset. *Formularies* (datasets) are uniquely named configurations that may differ in drugs, colors, dilutions, and comments to accommodate different practices within a single site or hospital (for example, pediatric versus cardiac).

Additional uses include producing labels for IVs and other artifacts used during a surgical procedure.

The Codonics SLS is generally placed in, however not limited to, the perioperative environment to identify syringes prepared for anesthesiology use during surgery.

Typical users of this system are trained professionals, including but not limited to physicians, nurses, and technicians.

The major characteristics and functions of the family of devices include:

- Scanning the drug container barcode directly from a vial or other type of container
- Decoding the manufacturer-issued barcode into the required FDA National Drug Code (NDC) or Unique Drug Identifier (UDI) number
- Referring the NDC/UDI number to a site-managed formulary lookup database
- Providing audio and ISO-compliant visual “readback” of the drug name
- Providing an alert if the drug container is listed as “recalled/obsolete” in the site’s formulary
- Printing an easy-to-read, water resistant ISO 26825 compliant color label meeting The Joint Commission medication management standards and the American Society of Anesthesiologists guidelines for labeling
- Providing the basic information by which the printed label barcode can be read to document medication administration in an AIMS
- Printing labels with insertion and expiration date and time for IV lines
- The SLS 600i PCS is prewired for future upgrades to support RFID reading and writing

Device Indications for Use Statement: Prescription Use Device

The Codonics SLS PCS device and SLS software provides a simple computer-based barcode scanning and printing system to automatically verify drug identity from NDC and other drug container UDI barcodes, and to print labels for prepared drugs and other items in use on patients during surgical procedures.

The Codonics SLS PCS is generally placed in, however not limited to, the perioperative environment to identify syringes prepared for anesthesiology use during surgery. Additional uses include producing labels for IVs and other artifacts used during a surgical procedure. SLS PCS can also be used to print “non-surgical environment” color and text labels as required. Typical users of this system are trained professionals, including but not limited to physicians, nurses, and technicians.



CAUTION Federal law restricts this device to be sold for use by or on the order of a physician.

DRAFT

1

Introduction

Welcome and Congratulations

Congratulations on your purchase of the Codonics® Safe Label System® Point of Care Station (SLS PCS) medication labeling system!



We are pleased that you chose SLS PCS. We are confident that it will provide safe, compliant, and fast medication labeling.

Product Features

Drug preparation and administration in the perioperative environment are integral aspects of anesthesiologist's patient care responsibilities. SLS PCS is a simple, integrated system utilizing a barcode scanner to read and confirm drug identity from FDA NDC (National Drug Code) and other drug ID barcodes from drug containers and automatically print labels for prepared drugs and other items in use on patients during surgical procedures. The labels are compliant with national regulations focused on improving medication safety in the perioperative environment.

The software components provide functions for scanning container barcodes; creating, reviewing, and approving the hospital-managed promotion of a formulary database; displaying on-screen and audibly confirming drug type; and printing ISO, ASTM, and TJC (The Joint Commission) content- and color-compliant labels with 1D and/or 2D barcodes. The system reads drug container barcodes and produces water resistant, color labels. The system can be integrated to function with an Anesthesia Information Management System (AIMS) workflow to provide real-time documentation of drug administration when the syringe barcode is read. The system can be accessed and managed via a network (Ethernet or Wi-Fi).

Hardware Features

- **Integrated printer** produces syringe labels that include medication name and concentration; dilutions and diluents; preparation time and date; preparer; and expiration time and date.
- **Embedded computer** including USB and an integrated speaker.

- **Touch screen display** with an intuitive, easy-to-use interface. System operation and status information is easily accessible from the touch screen interface.
- **Barcode scanner** identifies medications.
- **High-quality Codonics SLS inkjet cartridge and labels** provide reliable printing and adhesion for syringe labeling.
- **Convenient label media and ink cartridge access** is provided for ease of replacing labels and ink.
- **System operation and status information is easily accessible** from the touch screen interface.
- **Network capabilities via Ethernet or optional Wi-Fi** allow remote updating of SLS formulary, configuration, from the SLS Administration Tool.
- The SLS 600i PCS is prewired for future upgrades to support RFID reading and writing.

Operational Features

- **Easy to service** with Codonics Return to Factory Warranty. An optional DepotSwap Warranty program is also available, which provides a replacement SLS PCS if the problem cannot be solved by our Technical Support team. Also, the SmartDrive allows all configurations settings to be quickly transferred to a replacement SLS PCS. This minimizes downtime and reconfiguration effort.

2

Setting Up the System

Finding a Location for the System

When finding a suitable location for the system, use the following guidelines:

- Place the system in a location with adequate air circulation to prevent internal heat build up.
- Do not place the system near heat sources such as radiators or air ducts, or in a location subject to direct sunlight, excessive dust, mechanical vibration, or shock.
- Do not block air ventilation at the rear of the system.
- Make sure that the countertop or work surface supporting the system is level, can support the weight, and will not vibrate or shake when the system is operating.
- The device has mounting holes designed to be compatible with VESA mounting capabilities. Refer to www.vesa.org for mounting options and instructions.

Shipped Components

SLS PCS is shipped in cartons that contain the following system components:

- The SLS PCS device
- Supporting documentation package (including the SLS Quick Reference, Warranty, and support documents)

The following items are found in the Accessory Kit box:

- Label media hubs
- Output tray
- External power supply and cord
- SmartDrive USB flash drive
- Ethernet cable
- Reference Guide and other printed documentation
- Software and User's Manuals disc

Some configurations also include a Starter Kit that has one ink cartridge and one label media.

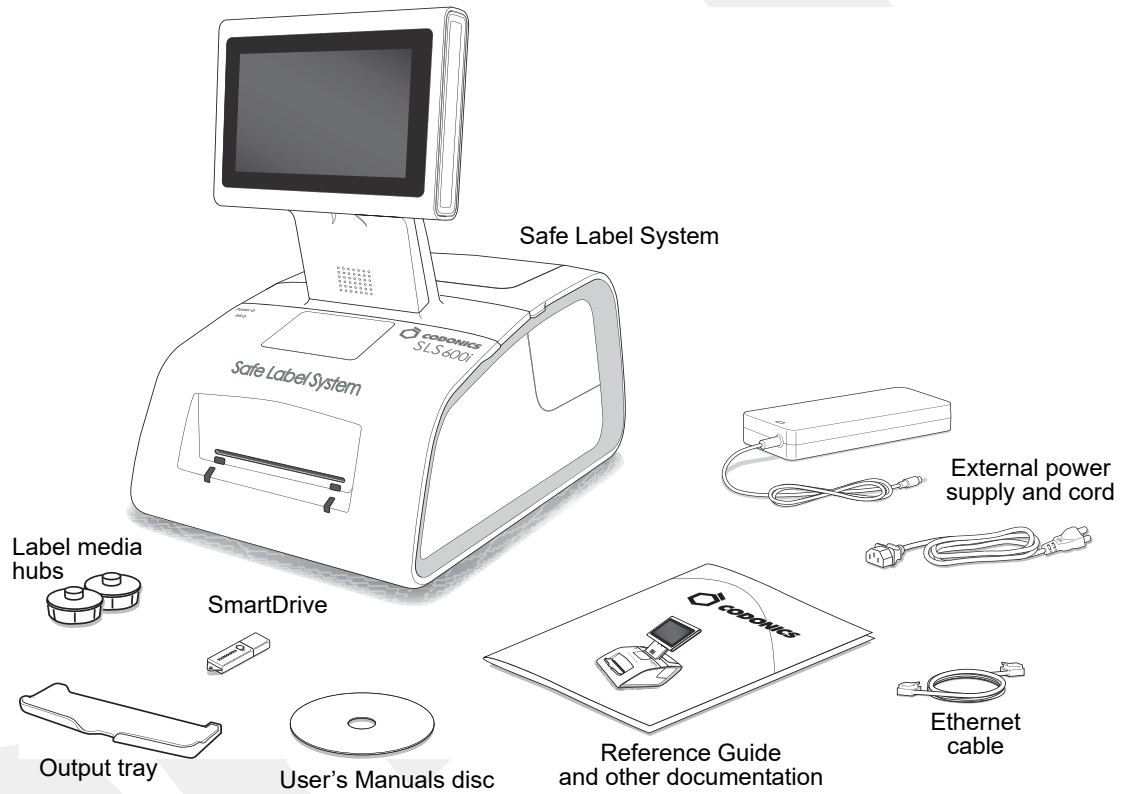

Unpacked components

Inspect the cartons for damage that might have occurred during shipping. Report any damage to the shipping company.

Save the cartons and packing materials, in case you ever need to transport SLS PCS later.



CAUTION When removing SLS PCS, hold under the front and rear of the system. Do not lift the system by the foam packaging.

Identifying the Components

SLS PCS Front Components

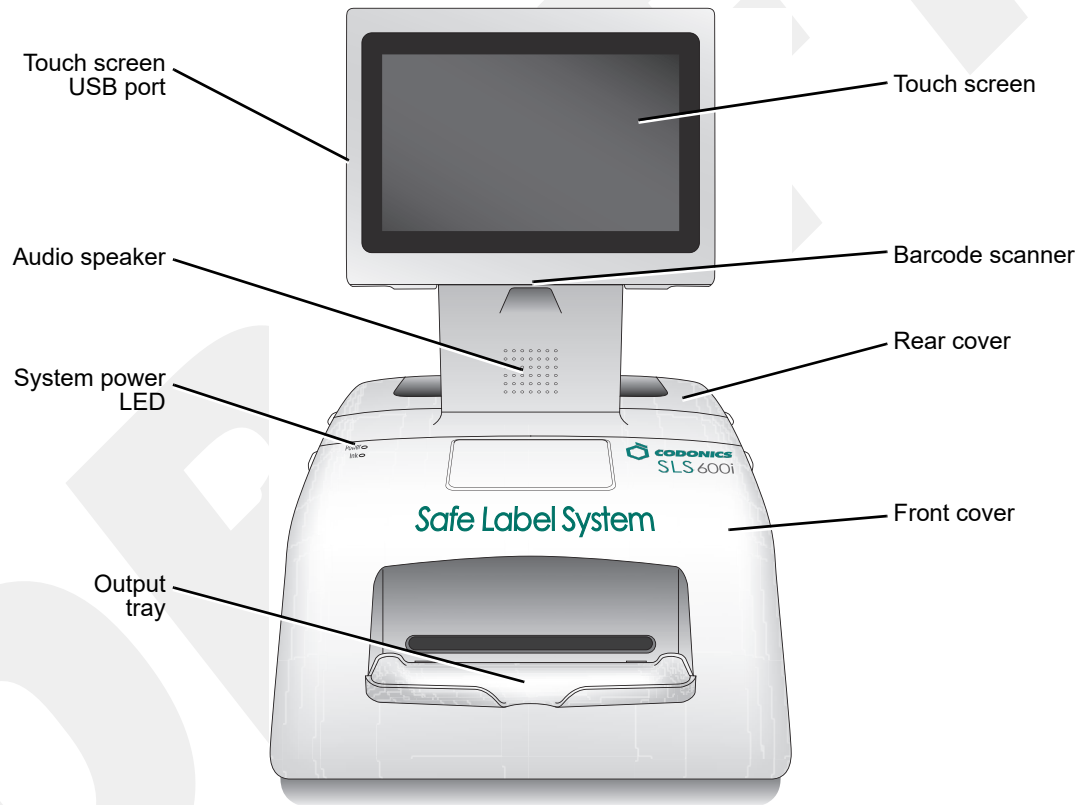

SLS PCS front components

- The **Touch Screen** displays the user interface to the system.
- The **Touch Screen USB Port** is used to install formulary update packages, configuration update packages, and software updates stored on USB flash drives.
- The **Audio Speaker** is used to announce drug names when a drug container's barcode is scanned, system messages, and other audio sounds.
- The **Barcode Scanner** scans drug container barcodes for identity and verification.
- The **Rear Cover** provides access to the label rolls.
- The **System Power LED** indicates when the system is powered on.
- The **Front Cover** is a durable plastic cover that protects SLS PCS from dust and accidental user interference while operating.



WARNING When the front cover is open, avoid contact with the label cutter.

- Printed labels are placed in the **Output Bin**.

Components Inside SLS PCS Front Cover

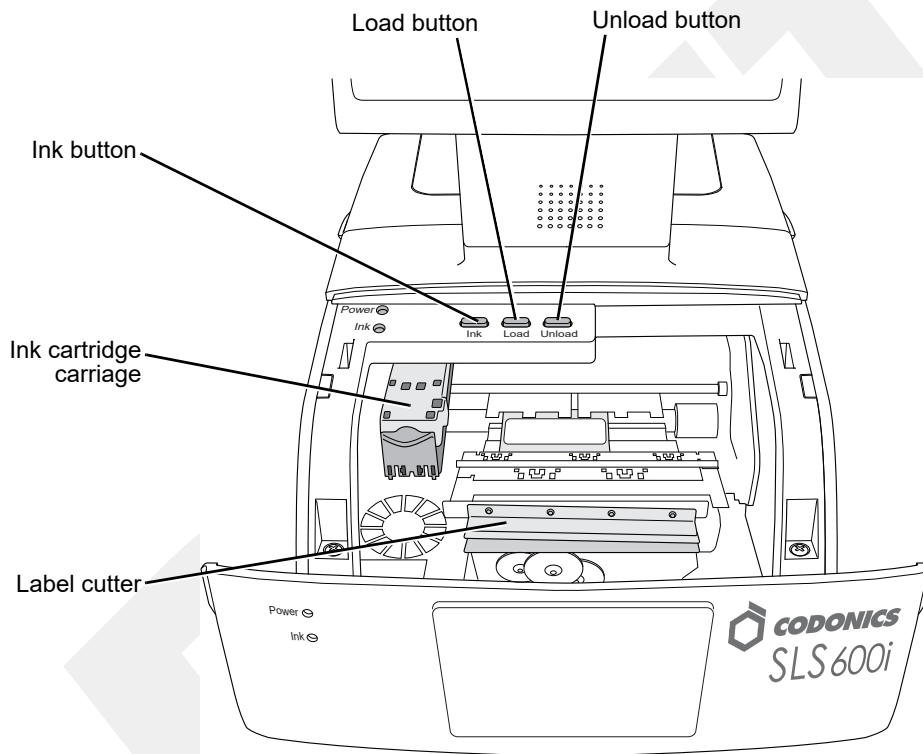

Components inside SLS PCS front cover

- Pressing the **Load Button** feeds the label media through SLS PCS and advances the labels.
- Pressing the **Ink Button** positions the ink cartridge carriage for easy ink cartridge replacement.

- Pressing the **Unload Button** unloads the installed label media by reversing it through SLS PCS.
- The **Ink Cartridge Carriage** holds the ink cartridge.
- The **Label Cutter** cuts the label after it is printed.



WARNING When the front cover is open, avoid contact with the label cutter.

- The wiring and connector on the inside of the front cover is for future RFID capability.

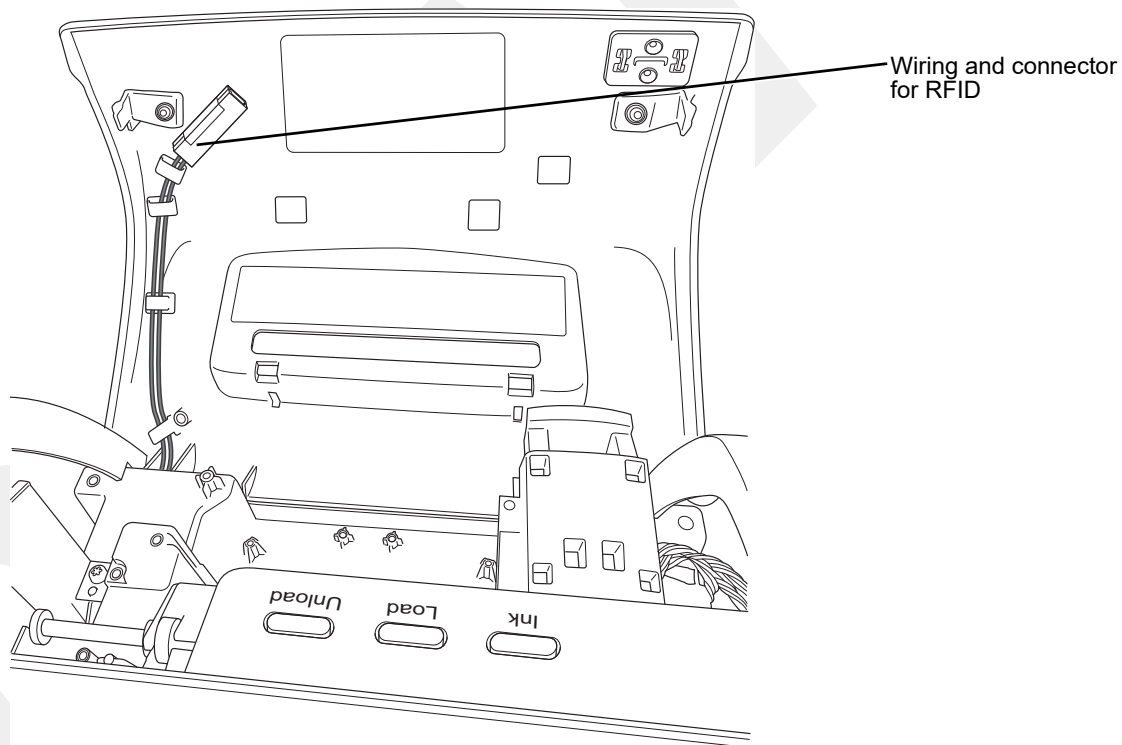

SLS PCS Rear Components

The following illustrations show the input/output ports and the power switch located at the rear of SLS PCS.

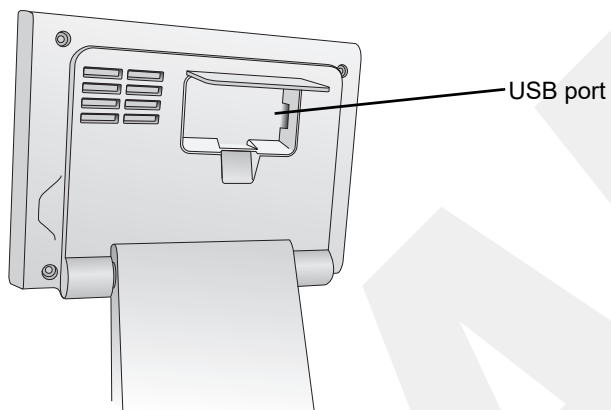

USB port, behind touch screen rear panel door

- The **USB port** behind the rear panel door is used to mount the SmartDrive flash drive.

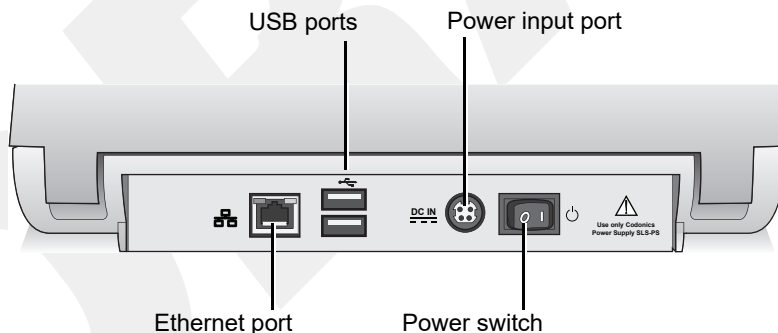

SLS PCS rear panel ports and Power switch

- The **USB ports** on the rear panel are used to connect third-party devices.
- The external power supply connects to the **Power input port**. The external power supply is a switching 100-V~240-V power supply.
- The **Power switch** powers SLS PCS on and off.
- The **Ethernet port** can be used to connect SLS PCS to a network.

SLS PCS Wi-Fi Adapter USB Port

The following illustration shows the USB ports for the optional Wi-Fi adapter, located at the bottom front right corner of SLS PCS.

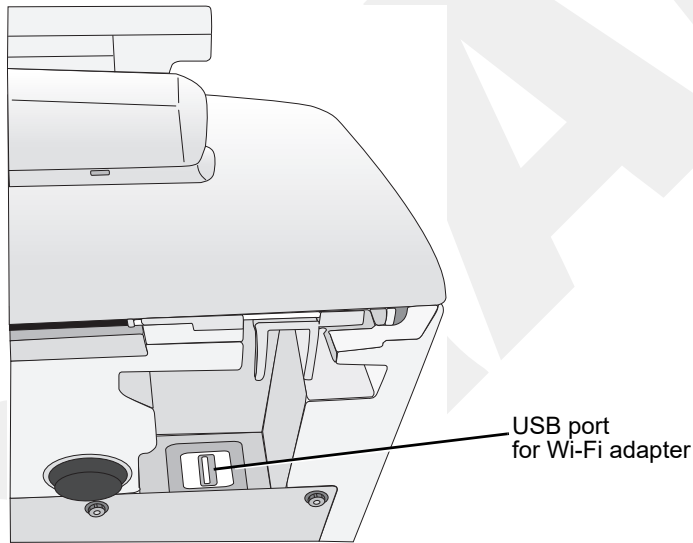

USB ports for Wi-Fi adapter, at the bottom front right corner of SLS PCS

MAC Address Label Locations

The MAC address might be needed by your SLS administrator when configuring the SLS PCS network connection.

The Ethernet MAC address label for SLS PCS is located inside the front cover, as shown in the following illustration.

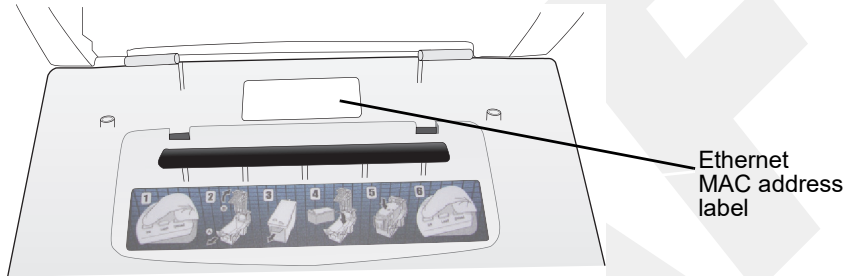

Ethernet MAC address label location, inside front cover

If using the optional Wi-Fi network connection, the Wi-Fi MAC address label for SLS PCS is located on the Wi-Fi adapter that is inserted into the SLS PCS Wi-Fi adapter USB port.

Touch Screen

The following illustration shows the touch screen Power LED, the Reset button, and the USB port at the left side of the touch screen.

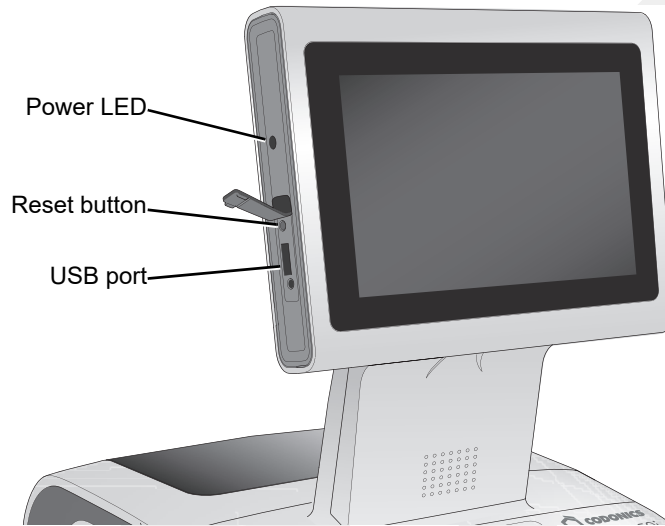

Reset button and USB port at left side of touch screen

- The **Power LED** lights when the touch screen is powered on.
- The **Reset button** is used to reboot the system software in the event of a critical failure. If required, use a pen or other pointed tool to press the Reset button.

NOTE: Do not use the Reset button unless directed to do so by Codonics Technical Support.

- The **USB port** is used for connecting USB flash drives that contain software and formulary updates.

Connecting the Ethernet Cable (Optional)

If you are connecting SLS PCS to a network using Ethernet, then you must connect an Ethernet cable to the SLS PCS.



NOTE: SLS PCS supports only Full Duplex 100 Base-T Ethernet.



To connect the
Ethernet cable

1. Connect one end of the Ethernet cable to an Ethernet hub or other Ethernet outlet that is connected to the network.

2. Plug the other end of the Ethernet cable into the Ethernet port on the rear panel of SLS PCS.

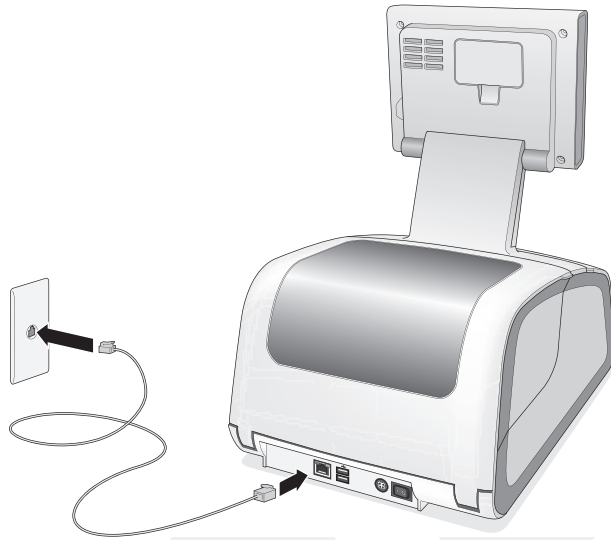

Connecting the Ethernet cable

For information about configuring the Ethernet network settings, refer to “Configuring an Ethernet Network Connection” on page 4-3.

Connecting the Wi-Fi Adapter (Optional)

If you are connecting SLS PCS to a network using Wi-Fi, then you must connect the Wi-Fi adapter to SLS PCS.



To connect the
Wi-Fi adapter

1. Locate the USB ports for the Wi-Fi adapter at the bottom front right corner of SLS PCS.
2. Insert the Codonics Wi-Fi adapter (catalog number SLS500-WIFI) into one of the USB ports.

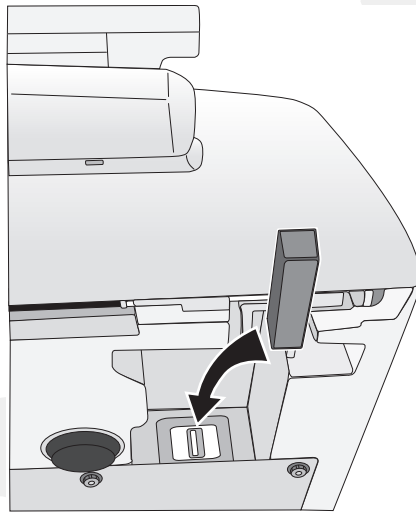

Connecting the Wi-Fi adapter



NOTE: The Wi-Fi adapter must be inserted before SLS PCS is powered on for the Wi-Fi connectivity to work properly. If SLS PCS is powered on when the Wi-Fi adapter is inserted, power SLS PCS off and then on again.

For information about configuring the Wi-Fi network settings, refer to either “Configuring an Enterprise Wi-Fi Network Connection” on page 4-9 or “Configuring a Non-Enterprise Wi-Fi Network Connection” on page 4-21.

Connecting the External Power Supply



To connect the external power supply

1. Locate the external power supply included with your SLS PCS.
2. Plug the external power supply into the Power Input port on the rear panel of SLS PCS.

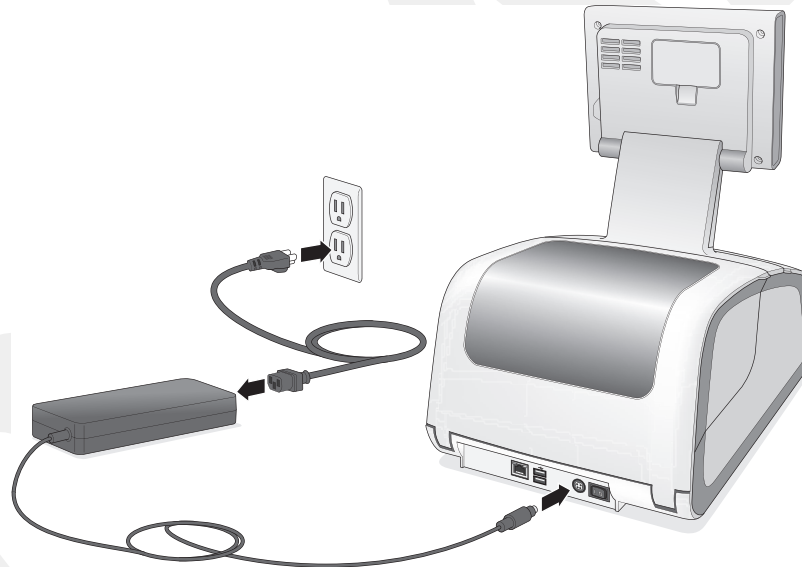

Connecting the external power supply

3. Connect the power cord from the external power supply to a grounded power outlet that supplies the appropriate voltage for the applicable country.



WARNING The power cord plug is the main disconnect for the device. The power outlet should be near the device and be easily accessible.



WARNING Remove the power cord plug from the power outlet to disconnect overall power to the device.



WARNING Grounding reliability can be achieved only when SLS PCS is connected to a receptacle marked “Hospital Only” (that is, “Hospital Grade”).

Once the external power supply is connected, SLS PCS can be powered on and off using the Power switch on the rear panel.

Inserting the SmartDrive



Insert the SmartDrive into the USB port inside the touch screen rear panel door.

To insert the
SmartDrive

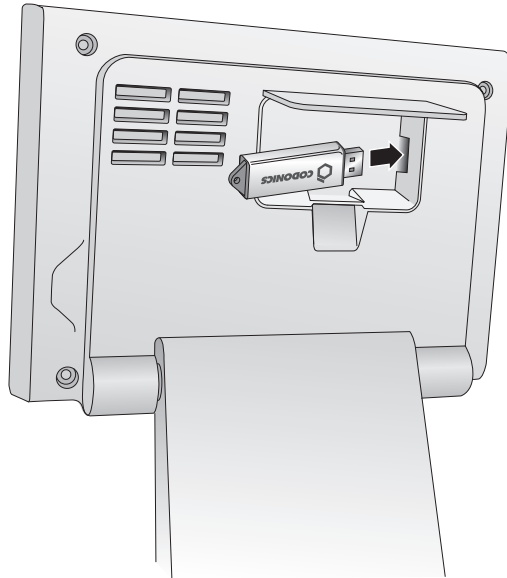

Inserting the SmartDrive into the USB port inside the touch screen rear panel door



NOTE: The rear panel door is not intended to be removed.

Starting Up the System



To start up the system

1. Press the Power switch on the rear of SLS PCS to power on and start up the system.

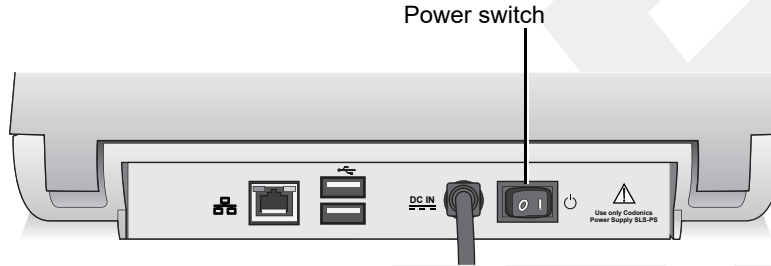

Power switch on the rear panel

When SLS PCS has completed its startup successfully, you are prompted to verify that the date and time are correct.

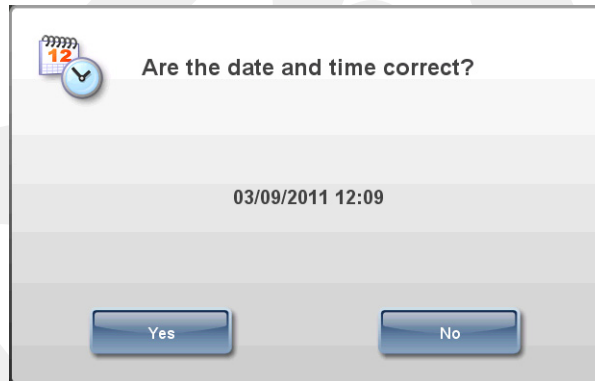

2. Press **Yes** if the date or time is correct.

The Login screen displays.

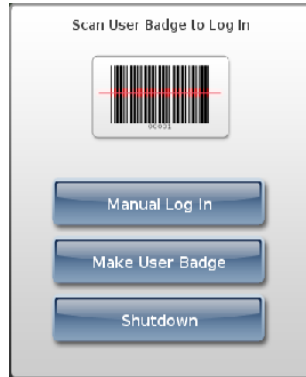

Press **No** if the date or time is incorrect.

Controls for changing the date and time display.

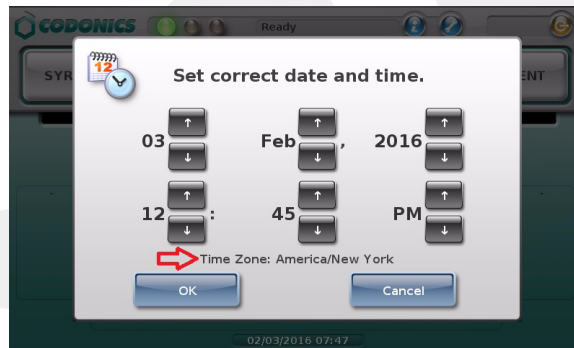

Note that when SLS PCS is configured for a specific time zone, it is displayed below the controls.

3. Use the controls to correct the date and time, then press the **OK** button.

The Login screen displays.



NOTE: If the SLS Administration Tool Device Manager is being used to monitor the status of this SLS PCS, make sure that the date/time entered is the same as that on the PC on which the SLS Administration Tool is running. If SLS PCS is more than 30 days behind the SLS Administration Tool, no SLS PCS events will be reported to Device Manager. If the SLS PCS date is within 30 days but not the same, event reporting will not be optimal.



NOTE: If the system detects that the SmartDrive contains a newer version of software, or that a USB flash drive contains an update package, you will be prompted to install the update. For more information, refer to "Installing Update Packages" on page 9-5.

Installing the Ink Cartridge

The dashboard on SLS PCS touch screen indicates when there is a low ink condition: The System status light is yellow and the status message text reports that the system is low on ink.

If there is no ink, the System status light will be red. During setup, this will be the condition until the ink cartridge is installed.



NOTE: SLS PCS is designed to work only with Codonics ink cartridges. To order ink cartridges, refer to "Ordering Supplies and Parts" on page 9-1. Using unapproved ink cartridges could lead to poor print quality and incorrect label colors.



NOTE: Never refill ink cartridges, as this can result in incorrect color usage and cause improperly printed labels.



NOTE: To prevent ink cartridges from drying out when opened, follow these instructions for installing the ink cartridge.



To install an ink cartridge

1. Open the front cover.
2. Press the Ink button.

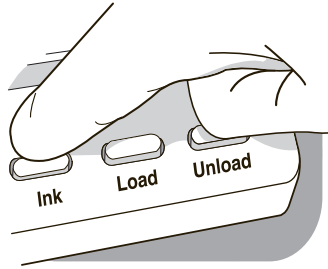

Ink button

3. Wait for the ink cartridge carriage to move to the right.

4. Open the carriage cover by pulling out on the purple hold-down clip. The cover is spring-loaded and will pop open.

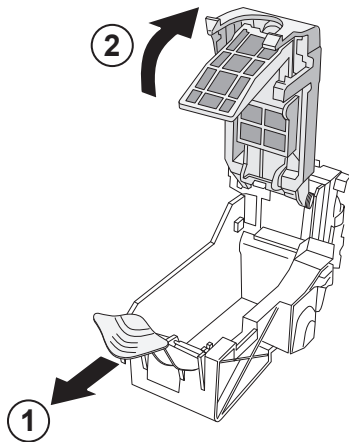

Opening the ink cartridge carriage cover

5. Remove the ink cartridge from its packaging. Once the ink cartridge is removed from its package, hold it by its sides.

6. Slowly remove the tape covering the cartridge's print head.

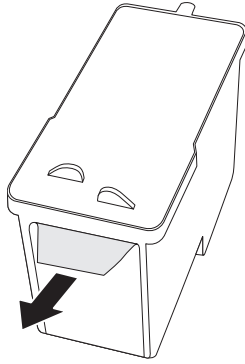

Removing ink cartridge print head tape



CAUTION Do not touch the copper area of the cartridge print head.

7. Insert the ink cartridge into its carriage, copper end first.

Hold the cartridge at a 45° angle as you slide it into its carriage, then push the cartridge down and toward the back until it fully drops into place.

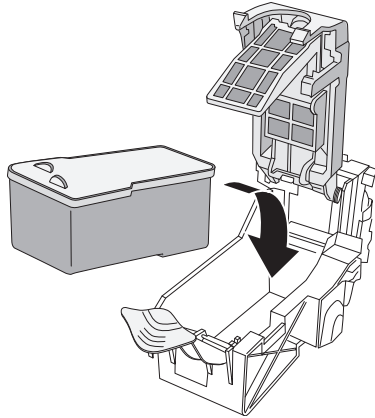

Loading the ink cartridge

8. Close the carriage cover until it snaps into place and is secured by the purple hold-down clip.

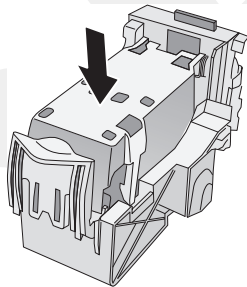

Carriage cover closed

9. Press the Ink button.

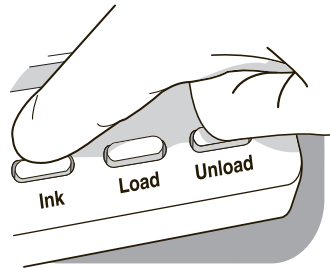

Ink button

10. Close the front cover.

Loading or Replacing the Label Media



NOTE: Use only Codonics labels to ensure proper operation of the device and proper labeling of syringes. Using unapproved labels could lead to unacceptable results, including poor print quality, and poor label adhesion to the syringe, and label jams.



NOTE: Unwanted labels should be destroyed or disposed of to ensure that improper labels are not used.



To load or
replace label
media

1. If the last label in the media roll is in the process of being printed, wait until the roll liner has finished rewinding before opening the rear cover.

This will prevent the label from not being cut and getting stuck inside SLS PCS. For more information, see “End of Media Roll Behavior” on page 2-30.

2. Open the rear cover.
3. Optionally, remove the rear cover for better access to the media path. For more information, refer to “Removing the Rear Cover” on page 9-12
4. Remove the loaded label media and hubs from the media guides.

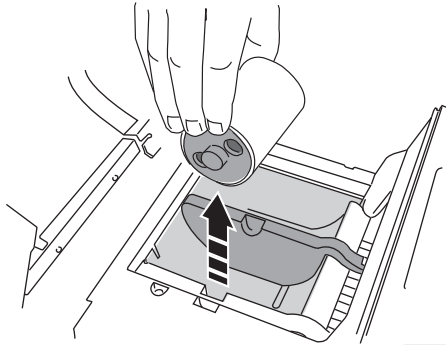

Removing the loaded label media

5. Remove any shipping tape or rubber bands from the new label media to ensure that it can unroll freely, making certain that no adhesive portion is exposed.



NOTE: Any exposed adhesive surface can attach itself to the inner workings of the print mechanism and cause a label jam.

6. Insert the hubs into the label media.

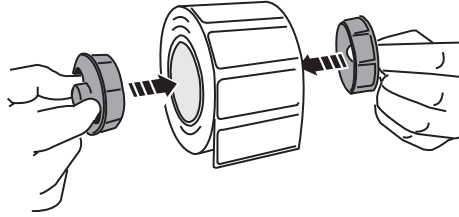

Inserting the hubs into the label media

7. Place the label media with hubs into the media guides.

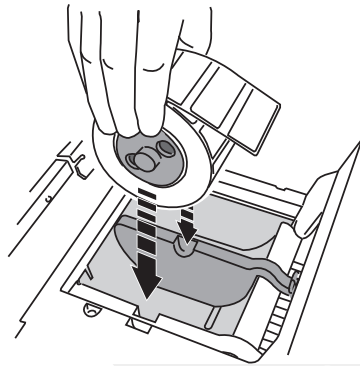

Placing the label media with hubs into the media guides

8. Adjust the media guides into position to securely hold the label media while allowing it to turn freely.

9. Place the leading edge of the label media below the two top media guides and into the feeder slot.

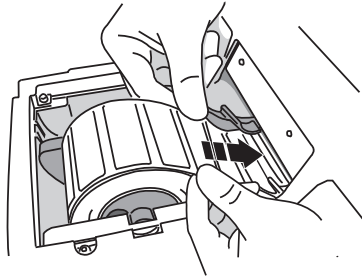

Placing the label media leading edge into the feeder slot

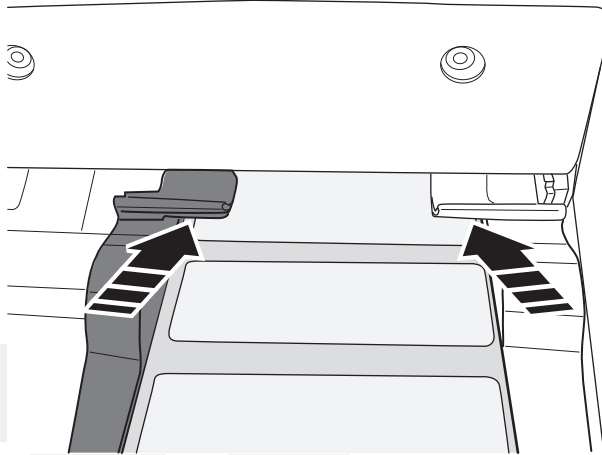

Label media fed beneath media guides

10. Feed the label media leading edge further into the feeder slot until SLS PCS senses the labels and automatically feeds them through. You might need to hold the label media in place for a few seconds.



NOTE: If SLS PCS fails to feed the label media, open the front cover, press the Unload button (shown below), remove the media from the media path, wait until the media path rollers stop spinning, and try loading the media again. If needed, press the Load button as you feed the media beneath the media guides.

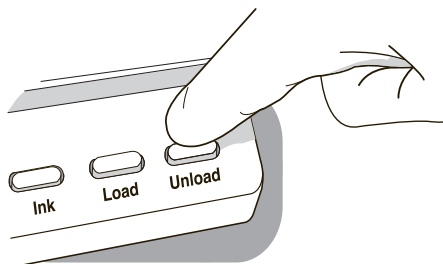

Unload button

End of Media Roll Behavior

At the end of a media roll, SLS PCS prints the last label, waits 10 seconds, cuts the last printed label, and then automatically rewinds the remaining liner.

You can then open the rear cover of SLS PCS, remove the media core, and load a new roll of media.

If you open the rear cover before the last label (or strip of labels in Batch Mode) is cut and press the Unload button, then SLS PCS will not cut the labels; it will only rewind the roll. If the last label has not been cut, there is a risk that, as the roll rewinds, a label could peel off and become stuck inside SLS PCS. Make sure that the last label has been cut before opening the rear cover to replace the media.

SmartDrive and Stored Information

The SLS SmartDrive is a USB flash drive that holds critical SLS information, including configuration data and log files.



CAUTION The SmartDrive must be inserted for the system to operate. If the SmartDrive is not inserted, the system can start up but will not be able to process jobs. A message at the touch screen will prompt you to insert the SmartDrive.

The SmartDrive also allows you to move the configuration files of one SLS PCS to another SLS PCS, thus allowing the second SLS PCS to operate exactly like the first. This feature is especially helpful when swapping an SLS PCS for service purposes.



NOTE: A SmartDrive cannot be duplicated. That is, it cannot be used in two SLS PCS units at the same time.

Information Stored on the SmartDrive

The SLS SmartDrive stores the following information:

- **The SLS Software License Code.** This is the serial number for the SLS software. All keyed features are keyed from the License Code.
- **The SLS Configuration.** This includes all of the system's configuration settings.
- **Formulary database.** This is a backup copy of the formulary database that is stored in SLS PCS.
- **User database.** This is a backup of the user database that is stored in SLS PCS.

- **Tracking database.** This is the database that is used to track user events (for example, when a user logs on or off the system, or when a user prints a label).
- **Log files.** These include installation logs, system logs, and event audit logs.

The SLS configuration, formulary database, tracking database and log files that are stored on the SmartDrive are encrypted to ensure the security of the data.

Events That Synchronize Data to the SmartDrive

The following events trigger a synchronization of SLS PCS data with that stored on the SmartDrive:

- Automatically every 15 minutes
- Shutting down the system
- Formulary updates