

Technical Manual

JBL CONTROL 26CT



SPECIFICATIONS

ACOUSTIC & ELECTRICAL SPECIFICATIONS:

- Nominal Impedance: 16 ohms
- Power Capacity: 140W Continuous Program
- Frequency Range: 75 Hz to 20 kHz
- Sensitivity: 89 dB, 1 Watt @ 1 Meter
- Crossover Frequency: 4 kHz

SYSTEM COMPONENTS:

- Cabinet: 389-00029-00
- Grille: 152mm (6in.)
- Woofer, Tweeter Transducer: 124-16000-00
- DC Resistance: 12.8 ohms
- Taps: 60W, 30W, 15W and 7.5W at 70V
60W, 30W, and 15W at 100V

SYSTEM COMPONENTS: (cont'd)

- Crossover Network: 129-20048-00

AURAL SWEEP TEST SPECIFICATIONS:

- A. System Aural Sweep Test: 12.0V* Input, 75 Hz to 20 kHz

PHYSICAL SPECIFICATIONS:

- Enclosure Dimensions: 210mm x 252mm Dia.
(8.3 x 9.9 in. Dia.)
- Shipping Weight: 20.5 lbs. (9.16 kg.) (in Pairs)

WARRANTY INFORMATION:

- Refer to Warranty Statement packed with each product.

PACKAGE

Warranty 59660
Owners Manual
CEILING SPKRMAN

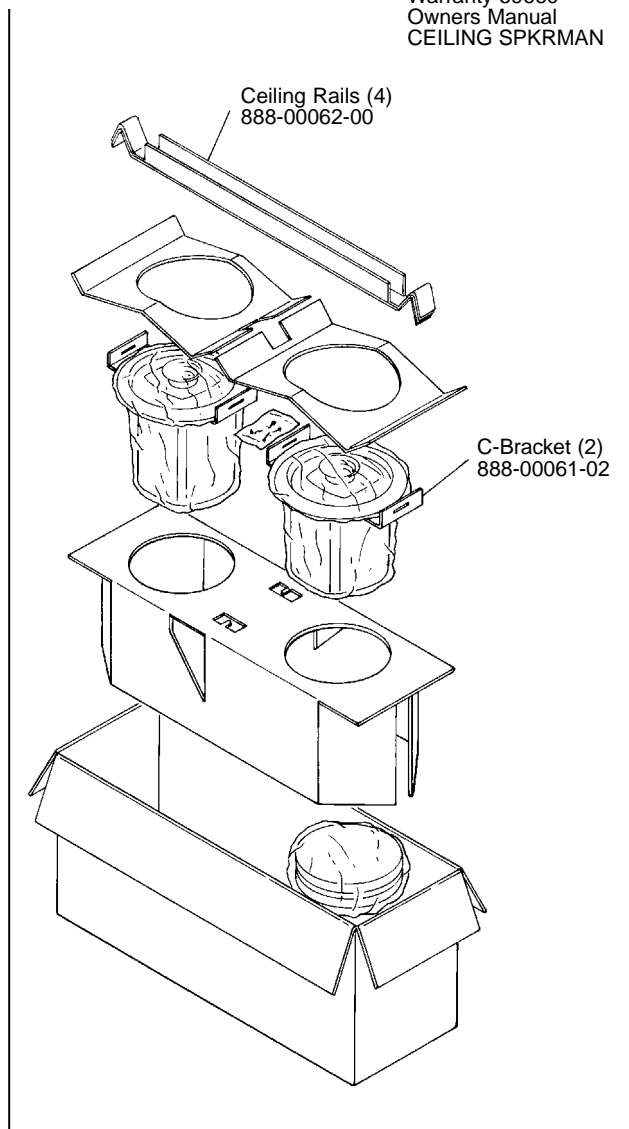

WIRING DIAGRAM

Woofer, Tweeter
124-16000-00

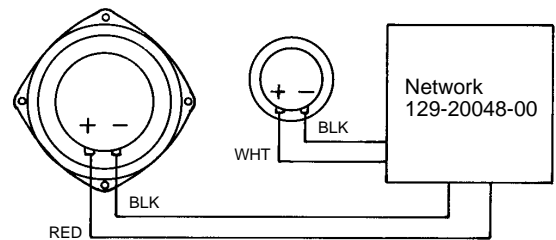

SCHEMATIC 129-20048-00

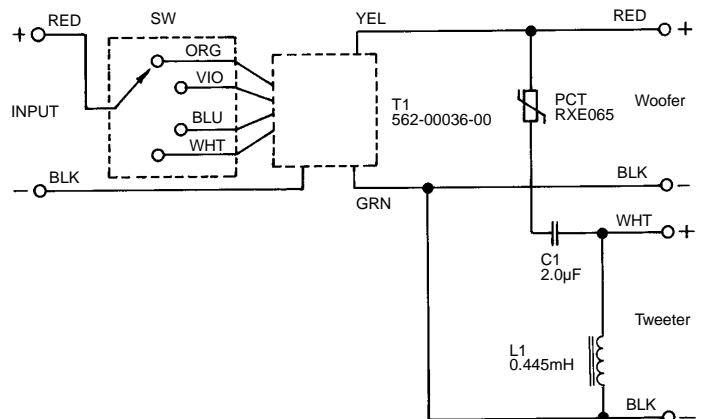

* NOTE:
All Models with Line Transformers are Tested at the Lowest Power Position (3.7W/70V for the 24CT, and 7.5W/70V for Both the 26CT and 19CST Models), with a Reversed Transformer in the Same Power Position Between the Speaker and the Amplifier.

JBL CONTROL 26CT REV A

COMPONENT EXPLODED VIEW
JBL CONTROL 26CT

