



**VT4886-DF88**

**VT4886-DF89**

## **VERTEC SUBCOMPACT DOWNFILL ADAPTERS**

### **USER GUIDE**

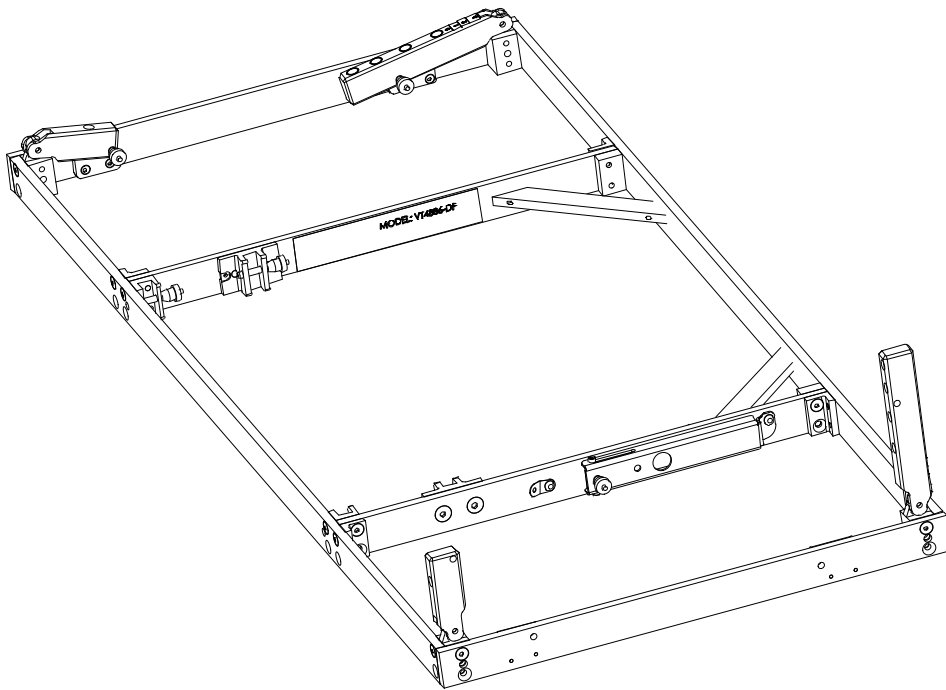

This page intentionally blank

## **IMPORTANT SAFETY INSTRUCTIONS**

1. Read these instructions.
2. Keep these instructions.
3. Heed all warnings.
4. Follow all instructions.
5. Do not use this apparatus near water.
6. Clean only with a dry cloth.
7. Do not block any ventilation openings. Install in accordance with manufacturer's instructions.
8. Do not install near any heat sources such as radiators, heat registers, stoves, or other apparatus that produce heat.
9. Only use attachments / accessories specified by the manufacturer.
10. Use only with a cart, stand, tripod, bracket, or table specified by the manufacturer or sold with the apparatus. When a cart is used, use caution when moving the cart / apparatus combination to avoid injury from tip-over.
11. Refer all servicing to qualified service personnel. Servicing is required when the apparatus has been damaged in any way, such as liquid has been spilled or objects have fallen into the apparatus, the apparatus has been exposed to rain or moisture, does not operate normally, or has been dropped.
12. Do not expose this apparatus to rain or moisture.
13. Hearing damage, prolonged exposure to excessive SPL: the loudspeaker is easily capable of generating sound pressure levels (SPL) sufficient to cause permanent hearing damage to performers, production crew and audience members. Caution should be taken to avoid prolonged exposure to SPL in excess of 90 dB.

## **PRECAUTIONS**

The VerTec series speakers covered by this manual are not intended for use in high moisture environments. Moisture can damage the speaker cone and surround and cause corrosion of electrical contacts and metal parts. Avoid exposing the speakers to direct moisture. Keep speakers out of extended or intense direct sunlight. The driver suspension will prematurely dry out and finished surfaces may be degraded by long-term exposure to intense ultra-violet (UV).

Vertec Subcompact Series speakers can generate considerable energy. When placed on a slippery surface such as polished wood or linoleum, the speaker may move due to its acoustical energy output. Precautions should be taken to assure that the speaker does not fall off a stage or surface on which it is placed.

## **SUSPENSION OF LOUDSPEAKER SYSTEM**

Before attempting to suspend your JBL loudspeakers, read and understand the following safety information.

## **IMPORTANT SAFETY WARNING!**

The information in this section has been assembled from recognized engineering data and is intended for informational purposes only. None of the information in this section should be used without first obtaining competent advice with respect to applicability to a given circumstance. None of the information presented herein is intended as a representation or warranty on the part of JBL. Anyone making use of this information assumes all liability arising from such use.

All information presented herein is based upon materials and practices common to North America and may not directly apply to other countries because of differing material dimensions, specifications, and/or local regulations. Users in other countries should consult with appropriate engineering and regulatory authorities for specific guidelines.

Correct use of all included hardware is required for secure system suspension. Careful calculations should always be performed to ensure that all components are used within their working load limits before the array is suspended. Never exceed the maximum recommended load ratings.

Before suspending any speaker system always inspect all components (enclosure, rigging frames, pins, eyebolts, track fittings, etc.) for cracks, deformations, corrosion, missing, loose or damaged parts that could reduce strength and safety of the array. Do not suspend the speaker until the proper corrective action has been taken. Use only load-rated hardware when suspending JBL suspendable loudspeaker models.

## **ARE YOU NEW TO RIGGING?**

If you are new to rigging, you should do the following:

- Read and study JBL Technical Note Volume 1, Number 14: Basic Principles for Suspending Loudspeaker Systems (available at [http://www.jblpro.com/pub/technote/tn\\_v1n14.pdf](http://www.jblpro.com/pub/technote/tn_v1n14.pdf))
- Know the rules for safe rigging.
- Attend a safe rigging seminar, such as that presented by professionals like Rigging Seminars™ ([www.riggingseminars.com](http://www.riggingseminars.com)) or by Chain Motor Hoist manufacturers like Columbus McKinnon Corp. (manufacturers of the C/M Lodestar).
- Meet and establish a relationship with a licensed mechanical or structural engineer. Get in the habit of asking them questions instead of guessing about their answers. Learn from what they tell you.
- Meet and discuss this aspect of your business with your Insurance Agent.
- Research and understand the codes, practices, and requirements in the venues where you intend to operate your sound system.

## **GENERAL HARDWARE INFORMATION**

Any hardware used in an overhead suspension application must be load rated for the intended use. Generally, this type of hardware is available from rigging supply houses; industrial supply catalogs and specialized rigging distributors. Local hardware stores do not usually stock these products. Hardware that is intended for overhead suspension will comply with ASME B30.20 and will be manufactured under product traceability controls. Compliant hardware will be referenced with a working load limit (WLL) and a traceability code.

## **ATTACHMENT TO STRUCTURES**

A licensed Professional Engineer must approve the placement and method of attachment to the structure prior to the installation of any overhead object. The following performance standards should be provided to the Professional Engineer for design purposes; Uniform Building Code as applicable, Municipal Building Code as applicable, and Seismic Code as applicable.

The installation of the hardware and method of attachment must be carried out in the manner specified by the Professional Engineer. Improper installation may result in damage, injury or death.

## **INSPECTION & MAINTENANCE**

Suspension systems are comprised of mechanical devices and, as such, they require regular inspection and routine maintenance to ensure proper function ability. Before suspending or pole mounting any speaker system always inspect all components (enclosure, suspension frames or brackets, pins, eyebolts, etc.) for cracks, deformations, corrosion, missing, loose or damaged parts that could reduce strength and safety of the array. Do not suspend or pole mount the speaker until the proper corrective action has been taken.

Installed systems should be inspected at least annually. The inspection shall include a visual survey of all corners and load bearing surfaces for signs of cracking, water damage, de-lamination, or any other condition that may decrease the strength of the loudspeaker enclosure.

Accessory suspension hardware provided with or for JBL VT4886 and VT4883 loudspeakers must be inspected for fatigue at least annually or as required by local ordinance. The inspection shall include a

visual survey of the material for signs of corrosion, bending or any other condition that may decrease the strength of the fastener. Additionally, any eyebolts shall be checked for possible spin-out of the enclosure.

**For all other hardware and fittings, refer to the hardware manufacturer's inspection and maintenance guidelines for process.**

JBL is not responsible for the application of its products for any purpose or the misuse of this information for any purpose. Furthermore, JBL is not responsible for the abuse of its products caused by avoiding compliance with inspection and maintenance procedures or any other abuse.

Prior to suspending the system, an expert, trained and experienced in suspending speaker systems should inspect all parts and components.

## RESOURCES

Adaptive Technologies Group  
562.424.1100  
1635 E. Burnett Street  
Signal Hill, CA 90755  
www.adapttechgroup.com

McMaster Carr  
Various Locations in the USA  
For a location near you, visit  
them at [www.mcmaster.com](http://www.mcmaster.com)

JBL Professional - Tech Note Vol. 1 No. 14  
"Basic Principles for Suspending Loudspeakers"  
[www.jblpro.com/catalog/support/getfile.aspx?docid=296&doctype=3](http://www.jblpro.com/catalog/support/getfile.aspx?docid=296&doctype=3)

## SAFE SUSPENSION

JBL suspendable version loudspeakers are supplied with built-in internal brackets. The systems are designed to facilitate the suspension of the loudspeaker by a qualified person familiar with rigging hardware and industry practices. Improper installation may result in damage, injury or death. If you are unfamiliar with Safe Rigging Practices you will need to consult with a qualified person familiar with rigging hardware and industry practices.

## WORKING LOAD LIMIT (WLL)

**VT4886-DF88 WLL = 280 lbs (127 kg)**

**8x VT4886 maximum**

**VT4886-DF89 WLL = 280 lbs (127 kg)**

**8x VT4886 maximum**

## WARNING

Suspension of JBL loudspeakers must employ a minimum of two (2) attachment points. When "bridling" a JBL loudspeaker system, two (2) legs of equal length must be used. The rear attachment points are pull-back points and are intended only for use in adjusting the down-angle of the speaker enclosure. Only the top and bottom attachment points are intended for use as suspension points.

## Hearing Damage, Prolonged Exposure To Excessive SPL

VerTec series loudspeakers are easily capable of generating sound pressure levels (SPL) sufficient to cause permanent hearing damage to performers, production crew and audience members. Caution should be taken to avoid prolonged exposure to SPL in excess of 90 dB.

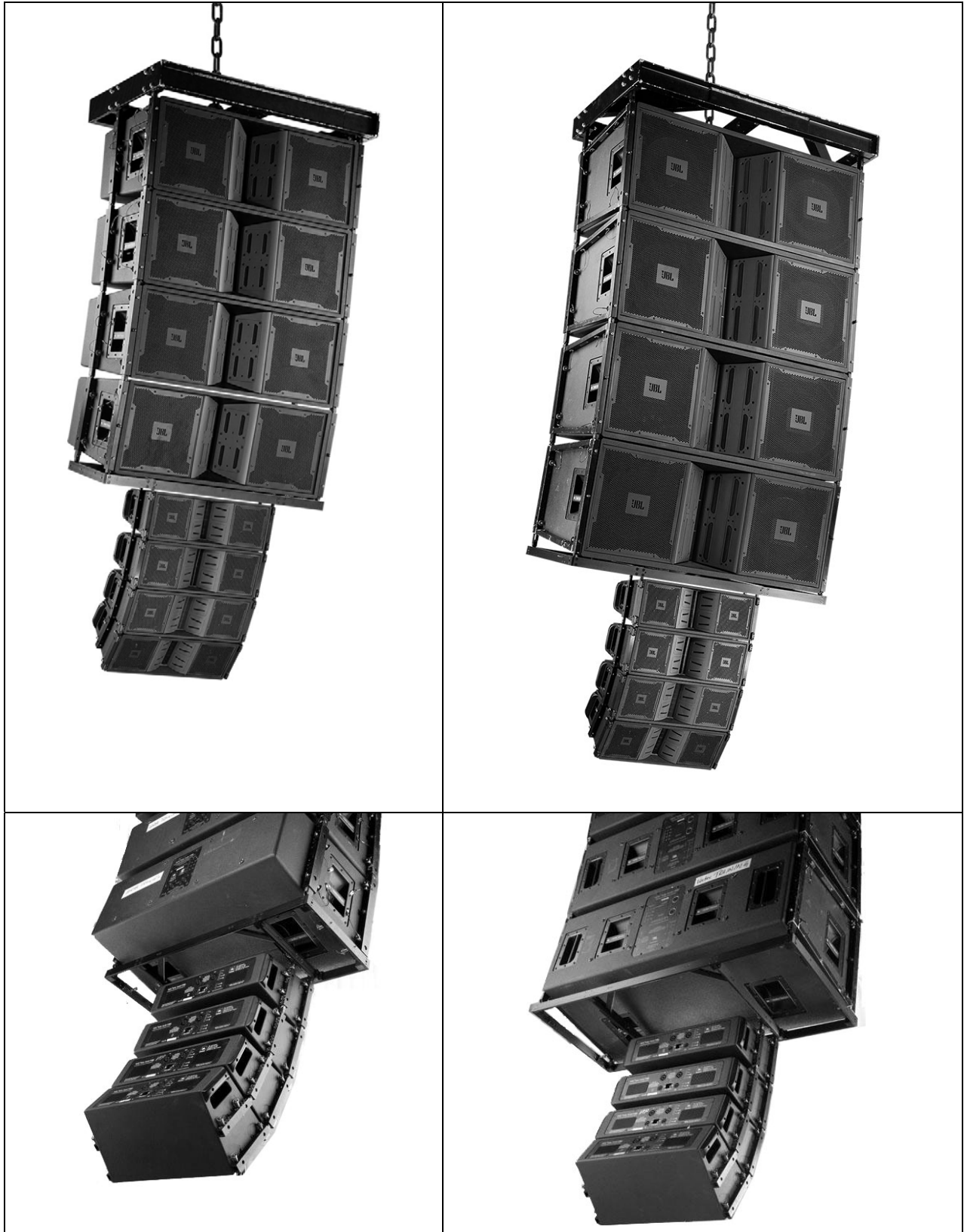

**Figure 1:** VT4886 suspended below VT4888 using VT4886-DF88 downfill adapter (left);  
VT4886 suspended below VT4889 using VT4886-DF89 downfill adapter (right)

**DESCRIPTION:**

The VT4886-DF88 and VT4886-DF89 Down Fill adapters allow up to eight VT4886 subcompact enclosures to be installed below VT4888 and VT4889 enclosures, respectively. As illustrated in Figures 2-4, relative angles from 0 to 12.5 degrees are possible.

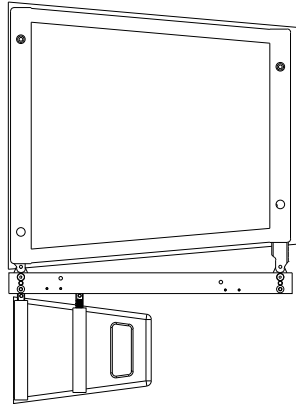

Figure 2: Zero degree relative site angle for VT4886 versus VT4889

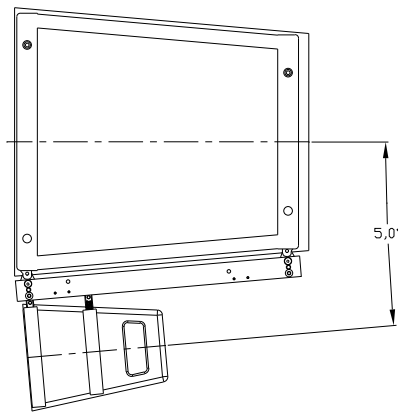

Figure 3: Upper hingebar adjustment provides relative site angles of 0, 1, 2, 3, 4 and 5 degrees (as shown) for VT4886 versus VT4889

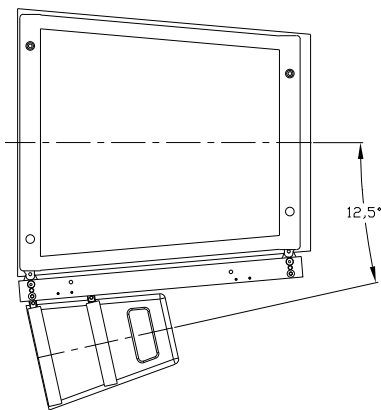

Figure 4: Lower hingebar adjustment provides relative site angles of 6, 7, 8, 9, 10, 11 and 12.5 degrees (as shown) for VT4886 versus VT4889

### VT4886-DF Hinge Bar Storage Sleeve

The VT4886-DF is supplied with a pair of rear adapter hinge bars in a built-in storage sleeve. Adapter hinge bars are required for attachment of the top VT4886 to the VT4886-DF. Figure 8 illustrates the location and function of the hinge bar storage sleeve. Standard VT4886 rear hinge bars can also be stored in the sleeve when rear adapter hinge bars are in use.

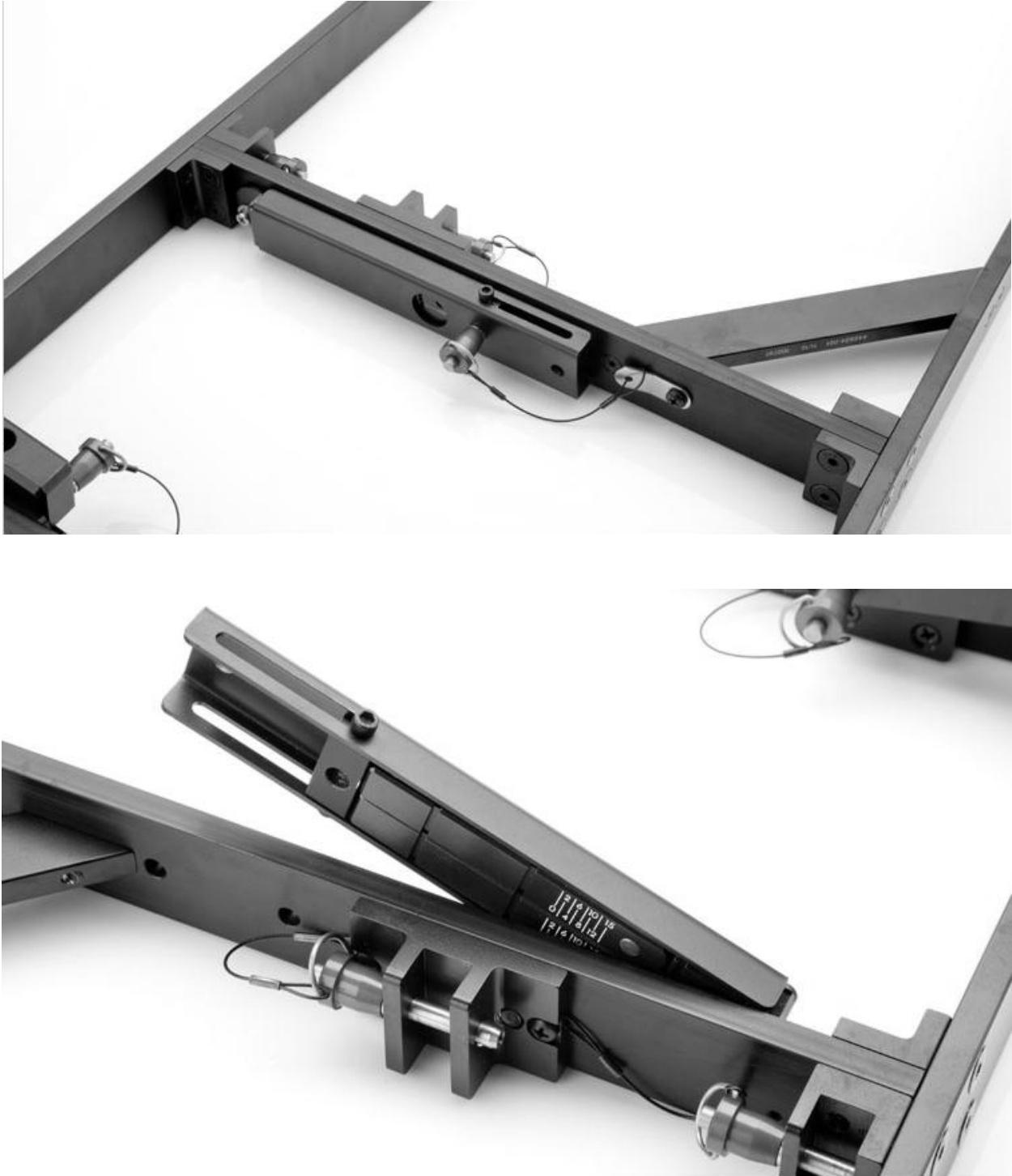
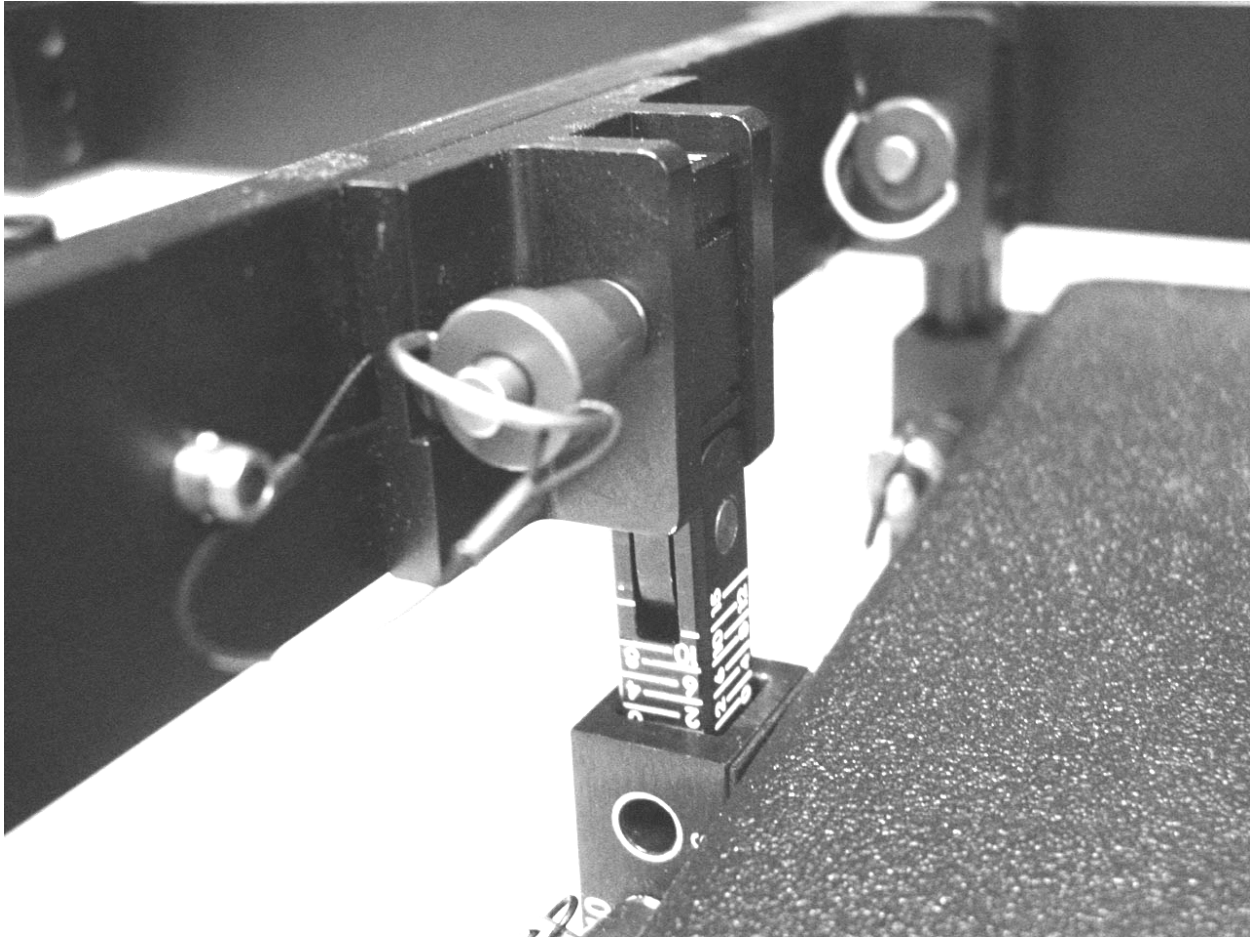

Figure 5: VT4886-DF hinge bar storage sleeve

### **VT4886-DF Attachment**

As shown in Figures 2 and 3, the VT4886-DF is attached to the top VT4886 enclosure to compensate for the 7.5 degree trapezoidal angle of the upper enclosure wall. This ensures that the site angle of the VT4886-DF is parallel to the site angle of the top enclosure, allowing the VT4886-DF to serve as a site angle reference for system installation. Adapter hingebar attachment is shown below in Figure 6. To achieve other relative angles between the bottom VT4889 or VT4888 and top VT4886 downfill enclosure, refer to the JBL Line Array Calculator Printout Page for attachment guidelines.



**Figure 6:** Select hole zero (top VT4886 enclosure) and the receiver block (hingebar recessed approx ½”) to attach VT4886-DF to the VT4886 using the supplied adapter hinge bars



Figure 7: VT4886-DF88 DOWNFILL ADAPTER

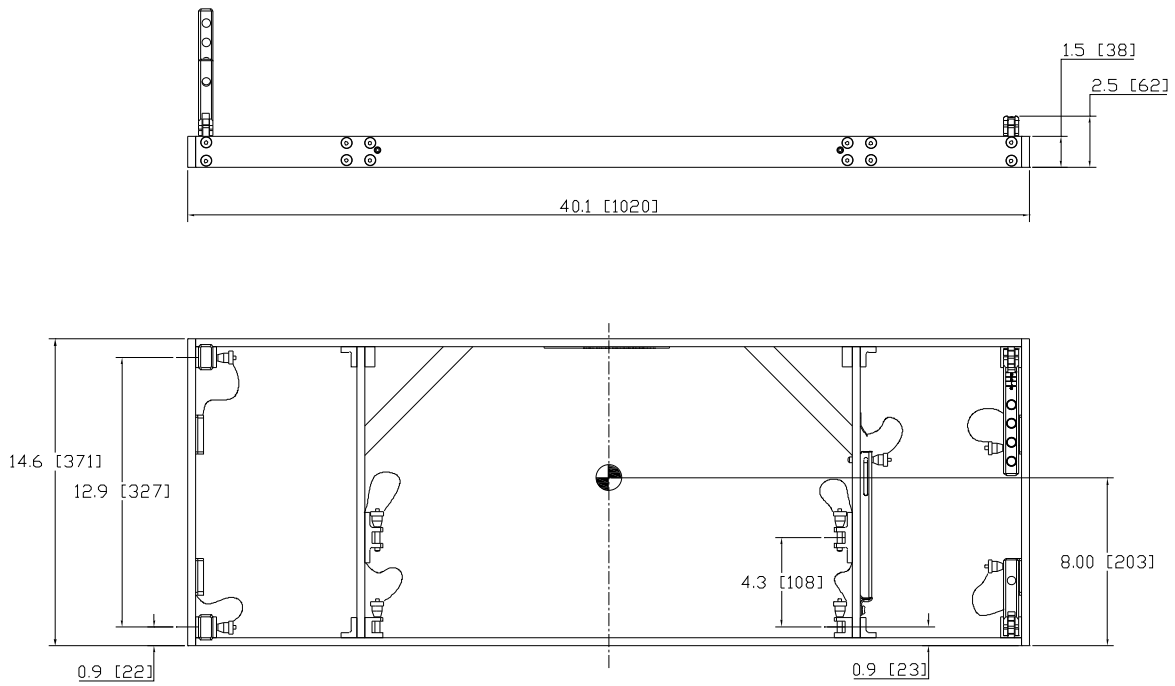

Figure 8: VT4886-DF88 Dimensions



Figure 9: VT4886-DF89 DOWNFILL ADAPTER

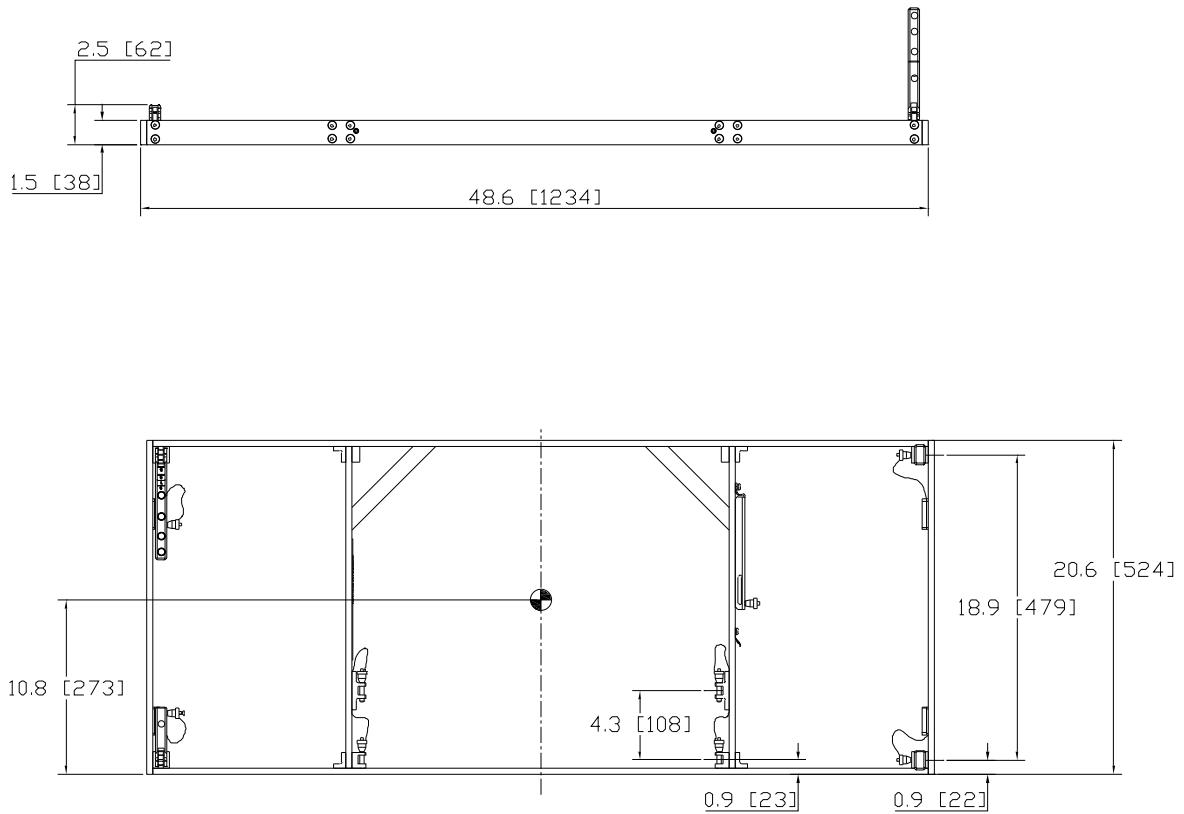

Figure 10: VT4886-DF89 Dimensions

## **JBL WARRANTY AND INFORMATION**

The JBL Warranty on professional loudspeaker products (except for enclosures) remains in effect for five years from the date of the first consumer purchase. JBL amplifiers are warranted for three years from the date of original purchase. Enclosures and all other JBL products are warranted for two years from the date of original purchase.

### **WHO IS PROTECTED BY THIS WARRANTY?**

Your JBL Warranty protects the original owner and all subsequent owners provided that:

A) Your JBL product has been purchased in the Continental United States, Hawaii or Alaska. (this Warranty does not apply to JBL products purchased elsewhere except for purchases by military outlets. Other purchasers should contact the local JBL distributor for warranty information); and B) The original dated bill of sale is presented whenever warranty service is required.

### **WHAT DOES THE JBL WARRANTY COVER?**

Except as specified below, your JBL Warranty covers all defects in material and workmanship. The following are not covered: Damage caused by accident, misuse, abuse, product modification or neglect; damage occurring during shipment; damage resulting from failure to follow instructions contained in your Instruction Manual; damage resulting from the performance of repairs by someone not authorized by JBL; claims based upon any misrepresentations by the seller; any JBL product on which the serial number has been defaced, modified or removed.

### **WHO PAYS FOR WHAT?**

JBL will pay all labor and material expenses for all repairs covered by this warranty. Please be sure to save the original shipping cartons because a charge will be made if replacement cartons are requested. Payment of shipping charges is discussed in the next section of this warranty.

### **HOW TO OBTAIN WARRANTY PERFORMANCE**

If your JBL product ever needs service, write or telephone us at JBL Incorporated (Attn: Customer Service Department), 8500 Balboa Boulevard, PO Box 2200, Northridge, California 91329 (818-893-8411). We may direct you to an authorized JBL Service Agency or ask you to send your unit to the factory for repair. Either way, you'll need to present the original bill of sale to establish the date of purchase. Please do not ship your JBL product to the factory without prior authorization. If transportation of your JBL product presents any unusual difficulties, please advise us and we may make special arrangements with you. Otherwise, you are responsible for transporting your product for repair or arranging for its transportation and for payment of any initial shipping charges. However, we will pay the return shipping charges if repairs are covered by the warranty.

### **Limitation Of Implied Warranties**

ALL IMPLIED WARRANTIES INCLUDING WARRANTIES OF MERCHANTABILITY AND FITNESS FOR PARTICULAR PURPOSE, ARE LIMITED IN DURATION TO THE LENGTH OF THIS WARRANTY.

### **EXCLUSION OF CERTAIN DAMAGES**

JBL'S LIABILITY IS LIMITED TO THE REPAIR OR REPLACEMENT, AT OUR OPTION, OF ANY DEFECTIVE PRODUCT AND SHALL NOT INCLUDE INCIDENTAL OR CONSEQUENTIAL DAMAGES OF ANY KIND. SOME STATES DO NOT ALLOW LIMITATIONS ON HOW LONG AN IMPLIED WARRANTY LASTS AND/OR DO NOT ALLOW THE EXCLUSION OF INCIDENTAL OR CONSEQUENTIAL DAMAGES, SO THE ABOVE LIMITATIONS AND EXCLUSIONS MAY NOT APPLY TO YOU. THIS WARRANTY GIVES YOU SPECIFIC LEGAL RIGHTS, AND YOU MAY ALSO HAVE OTHER RIGHTS, WHICH VARY, FROM STATE TO STATE.

## **CONTACT INFORMATION**

### **Mailing Address:**

JBL Professional  
8500 Balboa Blvd.  
Northridge, CA 91329

### **Shipping Address:**

JBL Professional  
Customer Service  
8500 Balboa Blvd., Dock 15  
Northridge, CA 91329  
(Do not return product to this address without  
first obtaining prior authorization from JBL)

### **Customer Service:**

Monday through Friday  
8:00am - 5:00pm  
Pacific Coast Time In the U.S.A.  
(800)8JBLPRO (800.852.5776)  
[www.jblproservice.com](http://www.jblproservice.com)

### **On The World Wide Web:**

[www.jblpro.com](http://www.jblpro.com)  
Professional Contacts, Outside The USA:  
Contact the JBL Professional Distributor in your area. A  
complete list of JBL Professional international distributors is  
provided at our U.S.A. website [www.jblpro.com](http://www.jblpro.com)

### **Product Registration:**

Register your product online at [www.jblpro.com/registration](http://www.jblpro.com/registration)

# EC-DECLARATION OF CONFORMITY



**Brand: JBL Professional**

**Family Name:** Vertec Series Suspension Hardware

**Model Name:** VT4800-CA, VT4800-DA, VT4800-UA, VT4886-AF, VT4886-UB, VT4886-UB1, VT4886-SF, VT4886-DF88, VT4886-DF89, VT4886-HB, VT4887-AF, VT4887-SF, VT4888-AF, VT4888-SF, VT4889-AF, VT4889-SF

**We, Harman International,** declare under our sole responsibility that the product, to which this declaration relates, is in conformity with the following standards.

Standard	Description	Testing Agency
EC MACHINE DIRECTIVE 2006/42/EC SECTIONS 4.1.2.3 & 4.1.2.5	MACHINE DIRECTIVE – Applies to machinery and lays down essential health and safety requirements	Tested at JBL

Copies of all Technical Data, Safety Data and EMC reports can be obtained by contacting Frank Lacelle at [frank.lacelle@harman.com](mailto:frank.lacelle@harman.com).

JBL Professional, part of the Harman International group of companies, declares that the products produced under the aforementioned brand names are designed and produced as professional audio speakers and therefore outside of the intended scope of the European Commission Regulation (EC) 1275/2008 of 17 December 2008 implementing Directive 2005/32/EC of the European Parliament and of the Council with regard to ecodesign requirements for standby and off mode electric power consumption of electrical and electronic household and office equipment.

<http://www.jblpro.com/catalog/support/getfile.aspx?docid=1528&doctype=3>

Harman International expects our suppliers and business partners to be aware of their obligations under REACH and expects any substances or products within the scope of REACH to be pre-registered before December 1, 2008. Given those conditions, our current products are exempt from REACH pre-registration and later registration activities. We provide separate E.U. Reduction of Hazardous Substances documentation for our RoHS compliant products.

<http://www.jblpro.com/catalog/support/getfile.aspx?docid=1529&doctype=3>

The WEEE directive (2002/96/EC) places an obligation on all EU-based manufacturers and importers to take-back electronic products at the end of their useful life. JBL, through its agent, accepts its responsibility to finance the cost of treatment and recovery of redundant WEEE in accordance with the specific WEEE recycling requirements. All of our products are marked with the WEEE symbol; this indicates that this product must NOT be disposed of with other waste. Instead it is the user's responsibility to dispose of their waste electrical and electronic equipment by handing it over to an approved re-processor, or by returning it to JBL's agent for reprocessing. For more information about where you can send your waste equipment for recycling, please contact your local distributor.

<http://www.jblpro.com/catalog/support/getfile.aspx?docid=1527&doctype=3>

JBL Professional, Northridge CA. USA 05/18/2010  
(Place and Date of issue)

Frank Lacelle Compliance Manager  
(Name and function of authorized person)

This page intentionally blank



JBL Professional  
8500 Balboa Blvd.  
Northridge, CA 91329 USA

PART NUMBER 445547-001