



Quick Start Guide



RRS24F-SD2

FCC ID: QJJ-590104

IC ID: 8226A-590104

Legal notice

JENOPTIK Robot GmbH
Opladener Strasse 202
D-40789 Monheim am Rhein
Germany
Telephone: +49 2173 3940-0
Fax: +49 2173 3940-169
www.jenoptik.com/ts

Legal notes

Contents

We strive to provide information that is correct, up to date and complete, and we have carefully prepared this document. Still, we cannot give any kind of warranty whatsoever for said information. We expressly exclude any liability for damage and consequential damage in any way related to the use of this document. We reserve the right to modify the documented products and product information at any time.

Data protection

The user as the owner of the data is responsible for the protection of any personal data that were created with the system. This applies particularly to the storage, transmission, blocking and deletion of personal data. The user must comply the applicable data protection regulations that are in force in the country where the user is registered. ROBOT Visual Systems GmbH cannot be held liable for any consequences resulting from misuse of the data or from offences committed by the user against the law with regard to the protection of personal data.

Copyright/Industrial property rights

Any texts, images, graphics and the like, as well as their arrangement, are subject to protection under copyright and other laws of protection. The reproduction, modification, transmission or publication of any part of this document or of the entire document in any form is prohibited.

The document serves the exclusive purposes of information and of operation in accordance with the regulations and does not justify any counterfeiting of the products concerned.

All signs contained in this document (protected marks, such as logos and trade names) are the property of ROBOT Visual Systems GmbH or of third parties and must not be used, copied or distributed without prior written consent.

Contents

1	Important information	4
1.1	Obligation to Read	4
1.2	Target Group.....	4
1.3	Storing the document.....	4
1.4	FCC / IC Compliance Information.....	4
2	Product Information	5
2.1	RRS24F-SD2 Functional Description	5
2.2	Technical Data RRS24F-SD2.....	6
3	Sensor Location	7

1 Important information

This document is designed to familiarize the user with the unit so that the unit is used for its correct purpose. This document provides important information. Following these instructions helps to avoid hazards and repair costs, and to reduce failure times.

1.1 Obligation to Read

This document must be carefully read, understood and applied by all persons who are involved in the operation of the unit or system. For your own safety, please read the Safety Instructions section with particular care. Following all instructions exactly will ensure that neither yourself nor any other person is put at risk and will avoid damage to the unit or system. Please contact the customer service of ROBOT Visual Systems GmbH if you have any questions that are not dealt with in this document.

1.2 Target Group

This document is aimed at qualified staff that has been specially trained to operate the unit.

1.3 Storing the document

This document must be kept for future use and made available to the staff at any time. Excerpts are not allowed.

1.4 FCC / IC Compliance Information

The K-Band RADAR device supplied with this product has been tested and found to comply with the limits for a Class A digital device, pursuant to Part 15 of the FCC Rules and with RSS-210 of Industry Canada.

These limits are designed to provide reasonable protection against harmful interference when the equipment is operated in a commercial environment. This equipment generates, uses, and can radiate radio frequency energy and, if not installed and used in accordance with the instruction manual, may cause harmful interference to radio communications. Operation of this equipment in a residential area is likely to cause harmful interference in which case the user will be required to correct the interference at his own expense.

Operation is subject to the following two conditions:

1. this device may not cause harmful interference, and
2. this device must accept any interference received, including interference that may cause undesired operation.

Changes or modifications made to this equipment not expressly approved by JENOPTIK Robot GmbH may void the FCC authorization to operate this equipment.

2 Product Information

The RRS24F-SD2 is a K-Band RADAR sensor intended for the monitoring of vehicle speed in road traffic. Features of the sensor are:

- Operates within the 24GHz ISM band.
- Transmitter power < 20dBm e.i.r.p., R&TTE conform.
- Continuous Wave (CW) transmission.
- Peak power transmission normal to the front face of the product (0° squint angle).
- Horizontal beam width, within -3dB limits, of $\pm 2,5^\circ$.
- Vertical beam width, within -3dB limits, of $\pm 10^\circ$.
- Speed in km/h, vehicle duration in meter, distance to vehicle in decimeter and vehicle direction for each measured vehicle.
- Single cable for power and communication.
- Communication using proprietary message protocol over standard '232 / '422 serial interface.

Typically the sensor is connected to an intelligent camera system that provides power and control. When activated the sensor sends a message to the camera in response to vehicles passing through its beam. Each message is analyzed in the camera and may trigger the recording of an evidence photograph.

2.1 RRS24F-SD2 Functional Description

The RRS24F-SD2 includes all components necessary for traffic speed monitoring in a single robust waterproof enclosure. Using a simple propriety command protocol the sensor can be configured as required by the measurement location. Once activated, the internal CPU translates the complex Doppler signal at the output of the transceiver into verified values of vehicle speed, distance, duration and direction. All valid measurements are forwarded automatically to the host using the serial interface. Only a single connection cable is required.

The sensor interface is optimized for use with an intelligent camera system from JENOPTIK Robot GmbH.

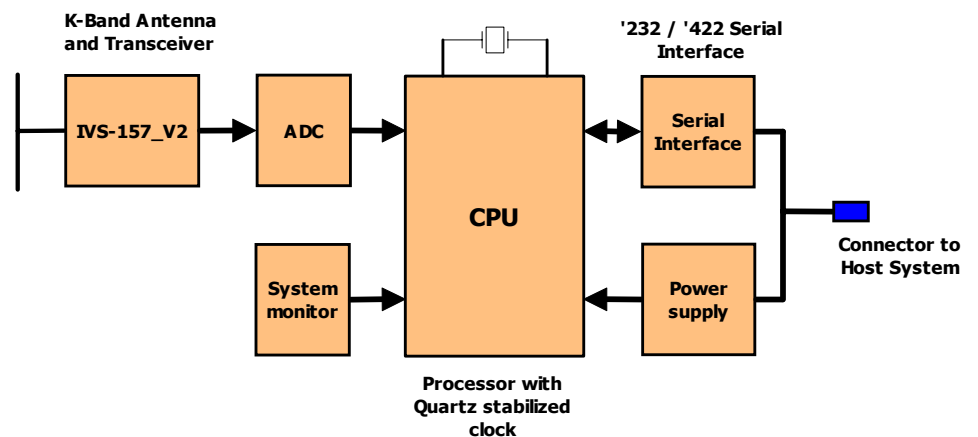

K-Band Antenna and Transceiver

IVS-157_V2 K-Band antenna and transceiver integrates the following parts:

- Patch array structure with a constant beam form and direction.
- K-Band transmitter with voltage controlled oscillator frequency.
- Low noise receiver and quadrature mixer.
- Dual base-band outputs of the recovered Doppler signal.

The direction of maximum transmitter power is normal to the face of the sensor. Measured between points 3dB below peak power, the beam width is $\pm 2,5^\circ$ in the horizontal direction and $\pm 10^\circ$ in the vertical direction. All side-lobes measured in the horizontal direction are at least 20dB below peak transmitter power.

The transmitter is active only when the sensor is placed in measurement modus by the host (camera).

ADC

The dual outputs of the IVS-157_V2 are digitized at a fixed rate. The continuous stream of samples is passed directly to the CPU for processing.

CPU

The CPU searches the stream of samples from the ADC for moving vehicles. When recognized, its speed and distance are measured throughout its passage through the Radar beam. On leaving, the acquired measurements are checked for quality and consistency, then corrected for the angle between vehicle motion and sensor direction (assumed to be 20°).

The verified speed/distance measurement is packed together with the vehicle duration in the radar beam and its direction. This package is then sent directly to the camera via the serial interface.

All speed and distance measurements are referenced to a quartz-stabilized clock.

Serial Interface

The serial interface operates in '232 or '422 modus, dependent on the connection cable used.

System Monitor

All supply voltages and the sensor temperature are constantly monitored. Should any parameter move out of tolerance, the measurement modus is immediately terminated and the transmitter shut down. The sensor then waits for the fault to be resolved prior to restarting speed measurement.

Power Supply

The supply from the camera is converted and regulated to the various voltages required by the sensor. All voltages, including the input supply voltage, are constantly compared to upper and lower tolerances. Operation of the sensor is only possible when all supply voltages are within tolerance.

2.2 Technical Data RRS24F-SD2

Measuring range:	10 km/h to 300 km/h	
Measuring accuracy:	10 km/h to 100 km/h	± 1 km/h
	100 km/h to 300 km/h	$\pm 1\%$

Traffic error limit:	10 km/h to 100 km/h	± 3 km/h
	100 km/h to 300 km/h	± 3%
Distance measurement:	1 m to 99 m	
Measuring angle:	20° with regard to the roadside border	
Squint angle:	0°	
Horizontal aperture angle:	5° (half-power width)	
Vertical aperture angle:	20° (half-power width)	
Sensitivity:	3 levels, selectable by host camera	
Direction of measurement:	selectable by host camera.	
Array Type:	IVS-157_V2	
Transmitter frequency:	24.1 GHz	
Transmitting power:	20dBm e.i.r.p. (R&TTE-conform)	
Weight:	2.2 kg	
Dimensions (W x H x D):	294 mm x 124 mm x 49 mm	

3 Sensor Location

There are several options available for assembly of the sensor at the measurement location. It is well suited to assembly on a tripod at the roadside; in a vehicle (moving or parked) or to assembly in a fixed radar enclosure. In all situations the following points are important for dependable and accurate measurement.

- The sensor assumes that the vehicle to be measured is moving at an angle of 20° to the radar beam, and corrects the measured speed appropriately. This requires that the front-face of the RRS24F-SD2 be mounted at 20° relative to the direction of vehicle motion (i.e. road edge).

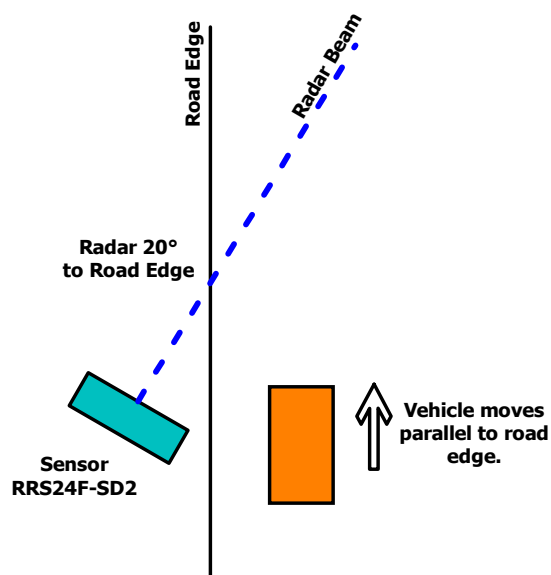

- There must be a clear space of at least four meters in front of the sensor in the direction of measurement.

- The radar beam must not be obstructed by obstacles such as parked cars, hedges, piles of sand or snow or similar.
- Measured from the sensor, the road section to be monitored must be straight for the following distances:
 - 30m for a single-lane road.
 - 40m for a double-lane road
 - 50m for a triple-lane road.

For this purpose a section of road can be considered straight when the shortest distance between a 35m long straight line and the road verge is not more than 0,1m (radius of band >1600m).

Following assembly at the measurement location the interface cable from the intelligent camera is attached to the sensor and the measurement modus activated using the camera GUI.