

# 3010-DA User's manual

## — 、 Wiring : Power Supply 12~16 DCV

### MODULE Connection instructional diagram

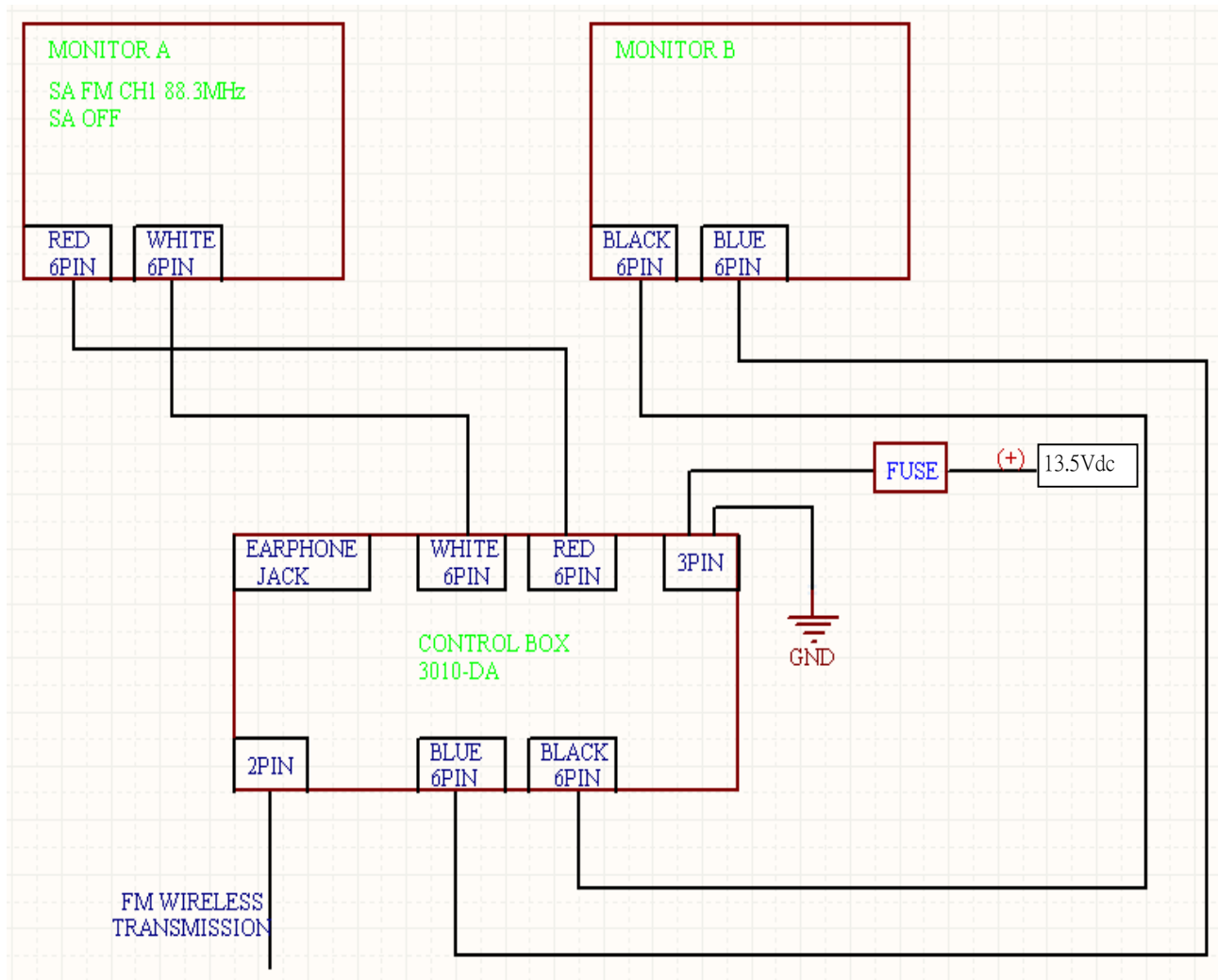

- 1 This product is car audio and video control box
- 2 Recommendations Please installation by professional technicians
- 3 Will pick a good line monitor A and monitor B 、  
each placed within the head restraint is being co-pilot ◦
- 4 Will take a good line Ccontrol Box ，  
Placed in the bottom of the co-pilot seat chairs ◦

## 二、Explanation & Specification :



Monitor A



Monitor B

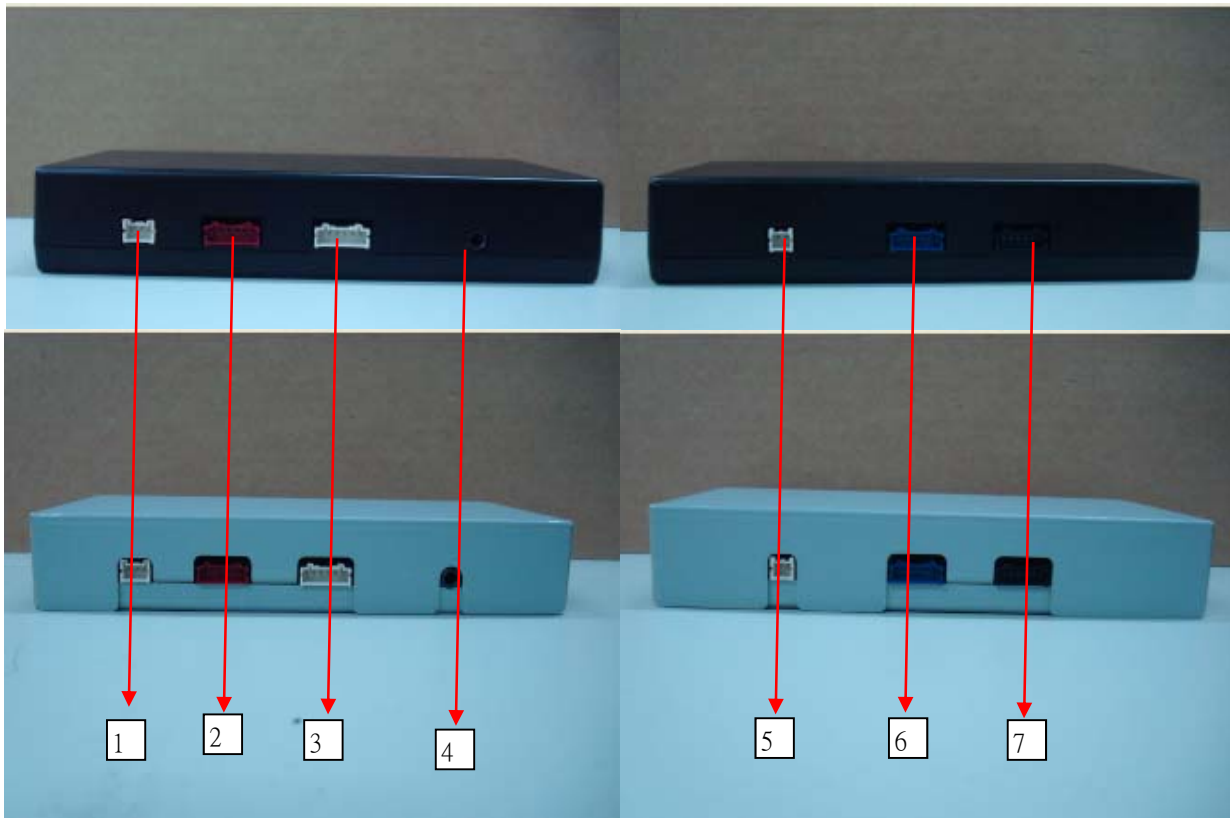

<b>WIRE CABLE FUNCTION NAME</b>	
<b>1</b>	To Power supply DCV : 12V~16V
<b>2</b>	To Monitor A Red Connector Power & AV Output
<b>3</b>	To Monitor A White Connector AV Input & I2C
<b>4</b>	To Ear phone Audio Aux Output
<b>5</b>	To FM Antenna Output 88.3 MHz ~107.7 MHz
<b>6</b>	To Monitor B Blue Connector AV Input & I2C
<b>7</b>	To Monitor B Black Connector Power & AV Output

FM Transmitter frequency : 88.3MHz ~107.7 MHz

### 三、 Operating Instructions

#### A. POWER ON/OFF

1. Press the Power key, opened the Monitor A and Monitor B. The look at the screen is normal



- B.** Monitor A SOURCE button to switch the screen (Monitor A. Monitor B. AUX. TV).  
Or press the Monitor B SOURCE button to switch the screen (Monitor B. AUX. TV. Monitor A).  
To each other to see the picture and sound are normal.



#### C. FM Modulator Playback

- 1 To listen to the audio portion of the viewed source through the vehicle's
- 2 stereo system aim the remote at the driver's side monitor and simply press the Sound Around (ON / OFF) button to turn the FM modulator on. The screen will now display FM SOURCE: Monitor A . The Audio portion of the source originating from the Driver's side headrest will now be audible through the vehicle's stereo. If a different audible source is desired, press the Sound Around (ON / OFF) button again to select Fm output ON and OFF. Once the desired audible source has been selected, the transmitting frequency the FM modulator transmits on can be changed by pressing the Sound Around (Select) button on the remote. Tune the vehicle's radio to the corresponding station to listen to the source that is displayed on the driver's side monitor.

To change the transmitting frequency, aim the remote at the driver's side monitor and press the Sound Around (Select) button. Each press of the button advances the frequency as follows:

(1. 88.3 , 2. 88.7 , 3. 89.1 , 4. 89.5 , 5. 89.9 , 6. 90.3 MHz Circulating).

The radio automatically search the radio to find the same with the Monitor A channel. Listen to the radio, the sound is clear with or without noise or interference (AUDIO sound source only from the Monitor A)



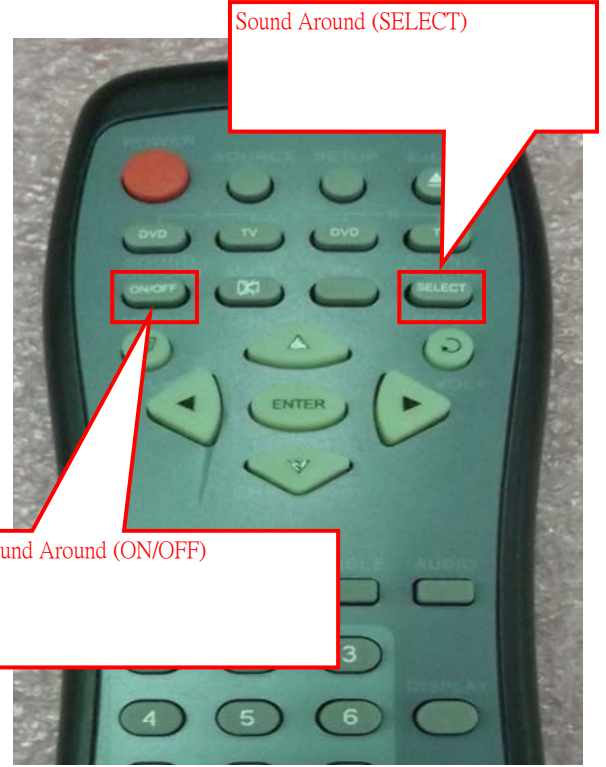

3 And then CH + / CH-(UP / DOWN) key, press the remote control the Sound Around (SELECT) button to start the FM the OSD Office Each time you press a frequency increment or decrement 200KHZ The whole frequency range of FM of CH 88.3 to FMCH 107.7MHZ. Using full-frequency (before 88.3 , 99.5 , 107.7 three) radio must also channel the correct position.



4 When you want to leave when not in use,

Press the power the key to turn off the Monitor A and Monitor B Power.



5 This video product is designed and intended for positioning in back seating areas of a vehicle where it cannot be viewed directly or indirectly by the driver and possibly cause him/her to be distracted from the task of operating the vehicle. Driver distraction is a major cause of accidents and for this reason many states specifically prohibit the viewing of motion video within view of the driver while the vehicle is in motion.

The REV-LT system features auxiliary component RCA input jacks on the A/V Control Module. Devices connected to this input can be viewed on either screen (independently or simultaneously), as well as output through the vehicle stereo via the 3010-DA Control Box FM Transmitter. To view this input press the SOURCE button until EXT. AUX is displayed.

NOTE: Consult your installer to determine how to access this input.

This Class B digital apparatus complies with Canadian ICES-003.

Cet appareil numérique de la classe B conforme à la norme NMB-003 du Canada.

This device complies with Industry Canada license-exempt RSS standard(s). Operation is subject to the following two conditions: (1) this device may not cause interference, and (2) this device must accept any interference, including interference that may cause undesired operation of the device.

Le présent appareil est conforme aux CNR d'Industrie Canada applicables aux appareils radio exempts. L'exploitation est autorisée aux deux conditions suivantes: (1) l'appareil ne doit pas produire de brouillage, et (2) l'utilisateur de l'appareil doit accepter tout brouillage radioélectrique subi, même si le brouillage est susceptible d'en compromettre le fonctionnement.

For product available in the USA/Canada market, only channel 1-11 can be operated. Selection of other channels is not possible.

This device and its antenna(s) must not be co-located or operation in conjunction with any other antenna or transmitter.

Under Industry Canada regulations, this radio transmitter may only operate using an antenna of a type and maximum (or lesser) gain approved for the transmitter by Industry Canada. To reduce potential radio interference to other users, the antenna type and its gain should be so chosen that the equivalent isotropically radiated power (e.i.r.p.) is not more than that necessary for successful communication.

### **Federal Communication Commission Interference Statement**

This equipment has been tested and found to comply with the limits for a Class B digital device, pursuant to Part 15 of the FCC Rules. These limits are designed to provide reasonable protection against harmful interference in a residential installation. This equipment generates, uses and can radiate radio frequency energy and, if not installed and used in accordance with the instructions, may cause harmful interference to radio communications. However, there is no guarantee that interference will not occur in a particular installation. If this equipment does cause harmful interference to radio or television reception, which can be determined by turning the equipment off and on, the user is encouraged to try to correct the interference by one or more of the following measures:

- Reorient or relocate the receiving antenna.
- Increase the separation between the equipment and receiver.
- Connect the equipment into an outlet on a circuit different from that to which the receiver is connect
- Consult the dealer or an experienced radio/TV technician for help.

This device complies with Part 15 of the FCC Rules. Operation is subject to the following two conditions:

- (1) This device may not cause harmful interference, and
- (2) this device must accept any interference received, including interference that may cause undesired operation.