

## IEEE802.15.4 / ZigBee uFL High Power Module Family

### Overview



This MD-120FA-5139A ZigBee Module is a surface mount modules with 100mW output power that enables users to implement IEEE802.15.4 or ZigBee compliant systems with minimum time to market and at the lowest cost. They remove the need for expensive and lengthy development of custom RF board designs and test suites. This module also provides an uFL connector with the ability to connect to the external antenna. It enables the system to extend the communication range. The modules provide a comprehensive solution with high radio performance and all RF components included. All that is required to develop and manufacture wireless control or sensing products is to connect a power supply and peripherals such as switches, actuators and sensors, considerably simplifying product development.

### Module Block Diagram

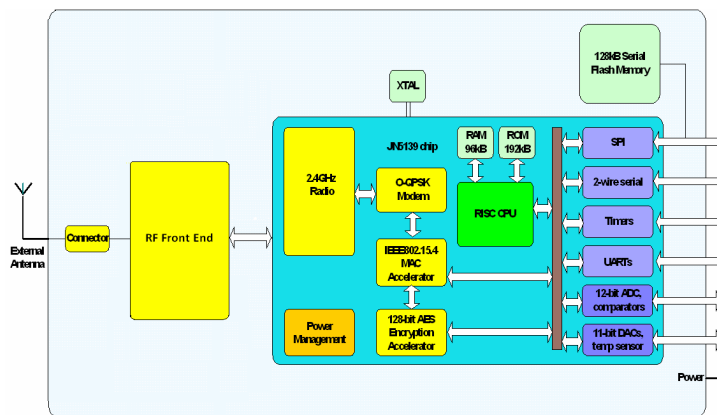

#### Benefits

- Microminiature module solutions
- Ready to use in products
- Minimizes product development time
- No RF test required for systems
- Compliant with FCC part 15 rules, IC Canada
- Long coverage with build-in power amplifier chip

#### Applications

- Robust and secure low power wireless applications
- Wireless sensor networks, particularly IEEE802.15.4 / ZigBee systems
- Home and commercial building automation
- Home networks
- Toys and gaming peripherals
- Industrial systems
- Telemetry and utilities (e.g. AMR)



#### Features: Module

- 2.4GHz IEEE802.15.4 & ZigBee Compatible
- 2.7-3.6V for SOC
- 3.0-3.6V for Power Amplifier
- Sleep Current ( with Active Sleep Timer ) 2.6µA
- Receiver Sensitivity -100dBm
- TX Power +20dBm
- TX Current 170mA
- RX Current 45mA
- Dimension : 40.5\*18\*3.5mm
- Weight : 3.0g

#### Features: Microcontroller

- 16MHz 32-Bit RISC CPU
- 96KB RAM, 192KB ROM
- 4-input 12-bit ADC, 2 11-Bit DACs, 2 Comparators, Temperature Sensor
- 2 Application Timer / Counters, 3 System Timers
- 2 UARTs (One for In-System Debug)
- SPI Port with 5 Selects
- 2-Wire Serial Interface
- 21 GPIO

**Temperature Range**  
-40°C to +85°C

**Humidity**  
10 to 95% RH

**Lead-Free and RoHS Compliant**

## Table of Contents

1.	Introduction .....	3
1.1	Key Features .....	3
1.1.1	Module .....	3
1.1.2	Microcontroller .....	3
1.2	Applications .....	3
2.	Specifications .....	4
3.	Pin Configurations .....	5
3.1	Pin Assignment .....	6
4.	Additional Information .....	8
4.1	Outline Drawing .....	8
4.2	Module PCB Footprint .....	9
4.3	Ordering / Label Information .....	10
4.4	Tape and Reel Information .....	11
4.4.1	Tape Orientation and dimensions .....	11
4.4.2	Cover tape details .....	11
4.4.3	Leader and Trailer .....	12
4.4.4	Reel Dimensions .....	12
4.5	SMT IR Profile .....	13
4.6	How to Avoid ESD Damage to ICs .....	13
5.	FCC Statement .....	14
6.	IC Statement .....	16
7.	Contact Information .....	18



## **1. Introduction**

This MD-120FA-5139A ZigBee Module is a surface mount modules with 100mW output power that enables users to implement IEEE802.15.4 or ZigBee compliant systems with minimum time to market and at the lowest cost. They remove the need for expensive and lengthy development of custom RF board designs and test suites. This module also provides an uFL connector with the ability to connect to the external antenna. It enables the system to extend the communication range. The modules provide a comprehensive solution with high radio performance and all RF components included. All that is required to develop and manufacture wireless control or sensing products is to connect a power supply and peripherals such as switches, actuators and sensors, considerably simplifying product development.

### **1.1 Key Features**

#### **1.1.1 Module**

- 2.4GHz IEEE802.15.4 & ZigBee Compatible
- 2.7-3.6V for SOC
- 3.0-3.6V for RF Front End
- Sleep Current ( with Active Sleep Timer ) 2.6 $\mu$ A
- Receiver Sensitivity -100dBm
- TX Power +20dBm
- TX Current 170mA
- RX Current 45mA
- Dimension : 40.5\*18\*3.5mm
- Weight : 3.0g

#### **1.1.2 Microcontroller**

- 16MHz 32-Bit RISC CPU
- 96KB RAM, 192KB ROM
- 4-input 12-bit ADC, 2 11-Bit DACs, 2 Comparators, Temperature Sensor
- 2 Application Timer / Counters, 3 System Timers
- 2 UARTs (One for In-System Debug)
- SPI Port with 5 Selects
- 2-Wire Serial Interface
- 21 GPIO

### **1.2 Applications**

- Robust and secure low power wireless applications
- Wireless sensor networks, particularly IEEE802.15.4 / ZigBee systems
- Home and commercial building automation
- Home networks
- Toys and gaming peripherals
- Industrial systems
- Telemetry and utilities (e.g. AMR)

## 2. Specifications

VDD=3.0V @ +25°C

Typical DC Characteristics		Notes
Deep Sleep Current	1.6uA	
Sleep Current	2.6uA	With active sleep timer
Radio Transmit Current	37mA	CPU in doze, radio transmitting
Radio Receive Current	37mA	CPU in doze, radio receiving
Centre Frequency Accuracy	±20ppm	Additional ±20ppm allowance for temperature and ageing
Typical RF Characteristics		Notes
Receive Sensitivity	-100dBm	Nominal for 1% PER, as per 802.15.4 section 6.5.3.3
Maximum Transmit Power (without PIFA Antenna)	+20dBm	With VPA=3.3V
Total Transmit Current	170mA	
Total Receive Current	45mA	
Maximum Input Signal	0dBm	For 1% PER, measured as sensitivity
RSSI Range	TBD	
RF Port Impedance -PIFA Antenna	50 ohm	2.4 - 2.5GHz
VSWR (Max)	2:1	2.4 - 2.5GHz
Peripherals		Notes
Master SPI Port	5 selects	250kHz - 16MHz
Slave SPI Port	✓	250kHz - 8MHz
Two UARTs	✓	16550 compatible
TwoWire Serial I/F (Compatible with SMBus & I <sup>2</sup> C)	✓	Up to 400kHz
Two Programmable Timer/Counters with Capture/Compare Facility, Tick Timer	✓	16MHz clock
Two Programmable Sleep Timers	✓	32kHz clock
Digital IO Lines (Multiplexed with UARTs, Timers and SPI Selects)	✓	
Four Channel Analogue-to-Digital Converter	✓	12-bit, up to 100ks/s
Two Channel Digital-to-Analogue Converter	✓	11-bit, up to 100ks/s
Two PProgrammable Analogue Comparators	✓	Ultra low power mode for sleep
Internal Temperature Sensor and Battery Monitor	✓	

### 3. Pin Configurations

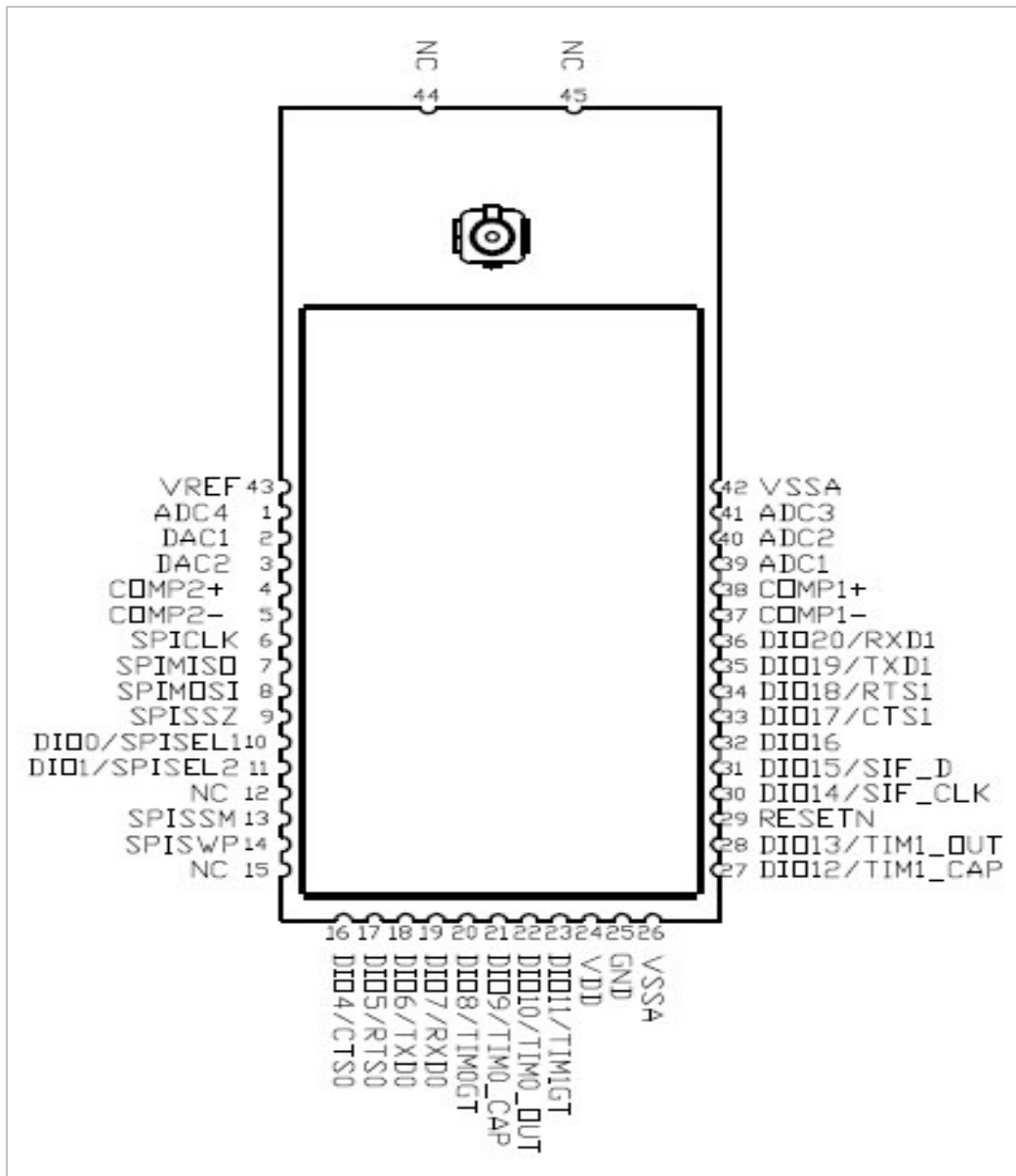

Figure : MD-120FA-5139A Pin Configuration(Top View)

Note: NC Pin such as Pin-12 (DIO3/SPISEL4) and Pin-15 (DIO2/SPISEL3) are not available on the high power modules.

### 3.1 Pin Assignment

Pin	Signal	Function	Alternative Function
1	ADC4	Analogue to Digital input	
2	DAC1	Digital to Analogue output	
3	DAC2	Digital to Analogue output	
4	COMP2+	Comparator 2 inputs	
5	COMP2-		
6	SPICLK	SPI master clock out	
7	SPIMISO	SPI Master In/Slave Out	
8	SPIMOSI	SPI Master Out/Slave In	
9	SPISZ	SPI select from module - SS0 (output)	
10	SPISEL1	SPI Slave Select1 (output)	General Purpose Digital I/O DIO0
11	SPISEL2	SPI Slave Select2 (output)	General Purpose Digital I/O DIO1
12	NC		
13	SPISSM	SPI select to FLASH (input)	
14	SPISWP	FLASH write protect (input)	
15	NC		
16	CTS0	UART0 Clear To Send (input)	General Purpose Digital I/O DIO4
17	RTS0	UART0 Request To Send (output)	General Purpose Digital I/O DIO5
18	TXD0	UART0 Transmit Data (output)	General Purpose Digital I/O DIO6
19	RXD0	UART0 Receive Data (input)	General Purpose Digital I/O DIO7
20	TIM0GT	Timer0 clock/gate (input)	General Purpose Digital I/O DIO8
21	TIM0_CAP	Timer0 capture (input)	General Purpose Digital I/O DIO9
22	TIM0_OUT	Timer0 PWM (output)	General Purpose Digital I/O DIO10
23	TIM1GT	Timer1 clock/gate (input)	General Purpose Digital I/O DIO11
24	VDD	3V power	
25	GND	Digital ground	
26	VSSA	Analogue ground	
27	TIM1_CAP	Timer1 capture (input)	General Purpose Digital I/O DIO12
28	TIM1_OUT	Timer1 PWM (output)	General Purpose Digital I/O DIO13
29	RESETN	Active low reset	
30	SIF_CLK	Serial Interface clock / Intelligent peripheral clock	General Purpose Digital I/O DIO14
31	SIF_D	Serial Interface data / Intelligent peripheral data out	General Purpose Digital I/O DIO15
32	DIO 16	Intelligent peripheral device select	General Purpose Digital I/O

Pin	Signal	Function	Alternative Function
33	CTS1	UART1 Clear To Send (input)	General Purpose Digital I/O DIO17
34	RTS1	UART1 Request To Send (output)	General Purpose Digital I/O DIO18
35	TXD1	UART1 Transmit Data (output)	General Purpose Digital I/O DIO19
36	RXD1	UART1 Receive Data (input)	General Purpose Digital I/O DIO20
37	COMP1-	Comparator 1 inputs	
38	COMP1+		
39	ADC1	Analogue to Digital input	
40	ADC2	Analogue to Digital input	
41	ADC3	Analogue to Digital input	
42	VSSA	Analogue ground	
43	VREF	Analogue peripheral reference voltage	
44	NC		
45	NC		

## 4. Additional Information

### 4.1 Outline Drawing

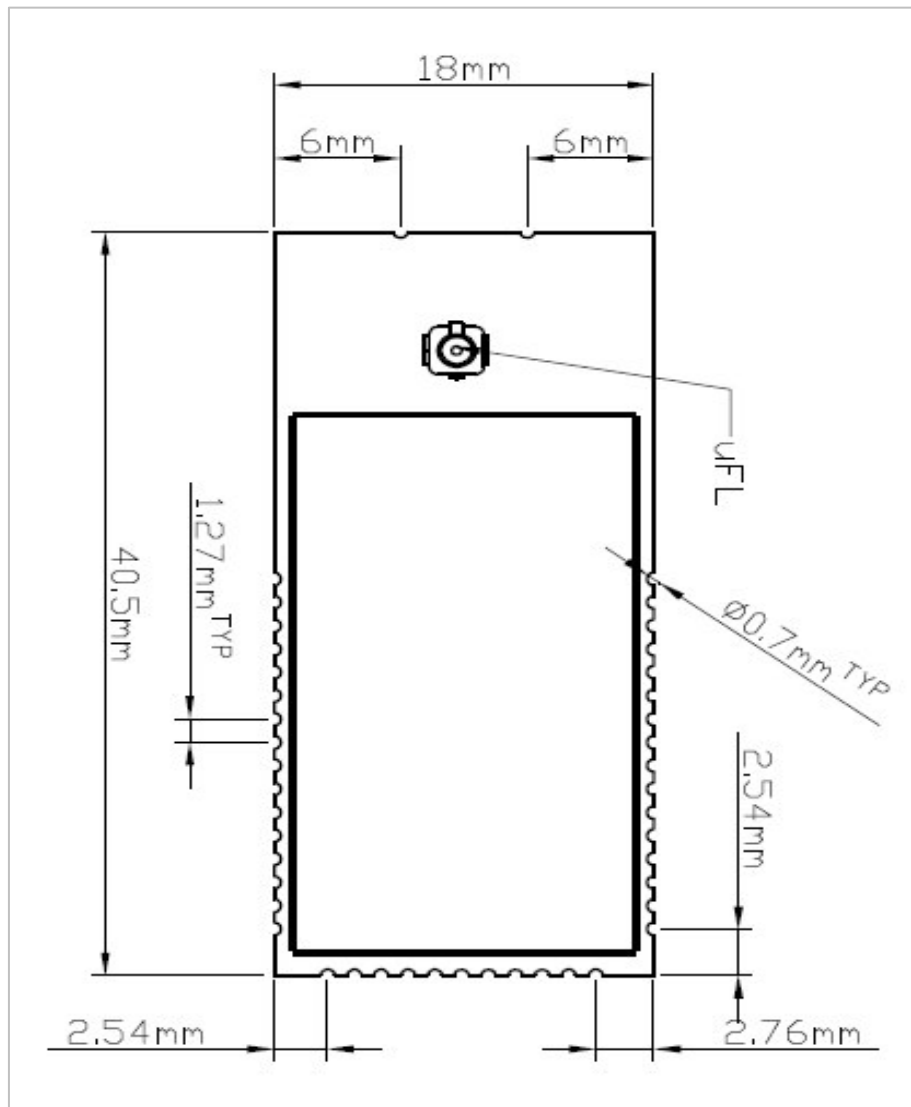

Thickness: 3.5mm

Figure : MD-120FA-5139A Outline Drawing



## 4.2 Module PCB Footprint

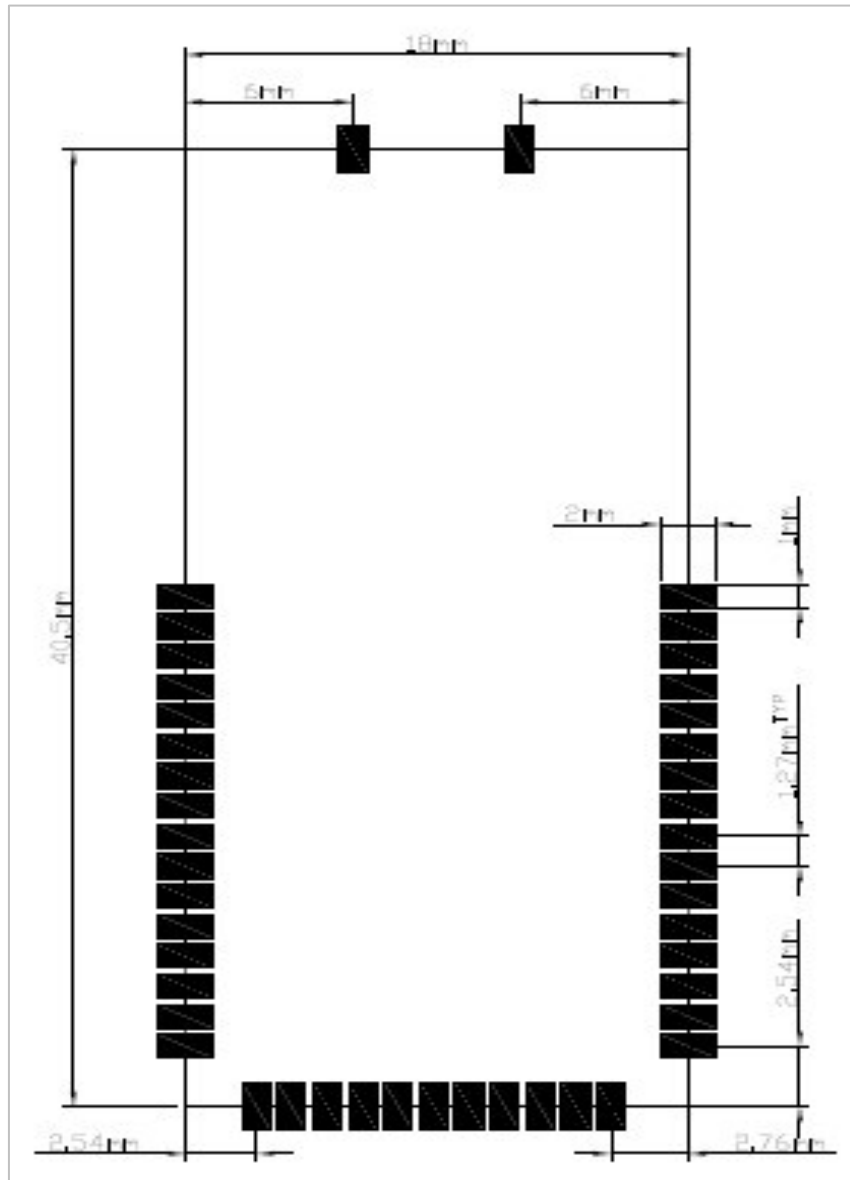
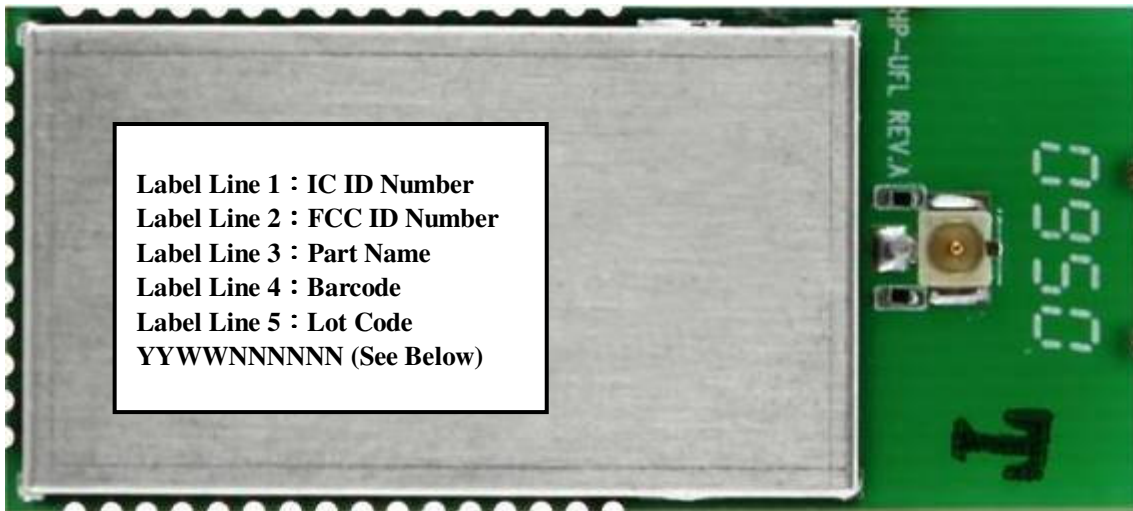

Figure : Module PCB footprint

**4.3 Ordering / Lable Information**



Label Line 1 : IC ID Number  
 Label Line 2 : FCC ID Number  
 Label Line 3 : Part Name  
 Label Line 4 : Barcode  
 Label Line 5 : Lot Code  
 YYWWNNNNNN (See Below)

Identifier	Description	Format
YY	Year	09 (Example)
WW	Week	34 (Example)
NNNNN	Serial Number	000001 (Example)

Figure : Example MD-120FA-5139A Labeling for FCC Approved Modules



**4.4 Tape and Reel Information**

**4.4.1 Tape Orientation and dimensions**

All dimensions are in mm

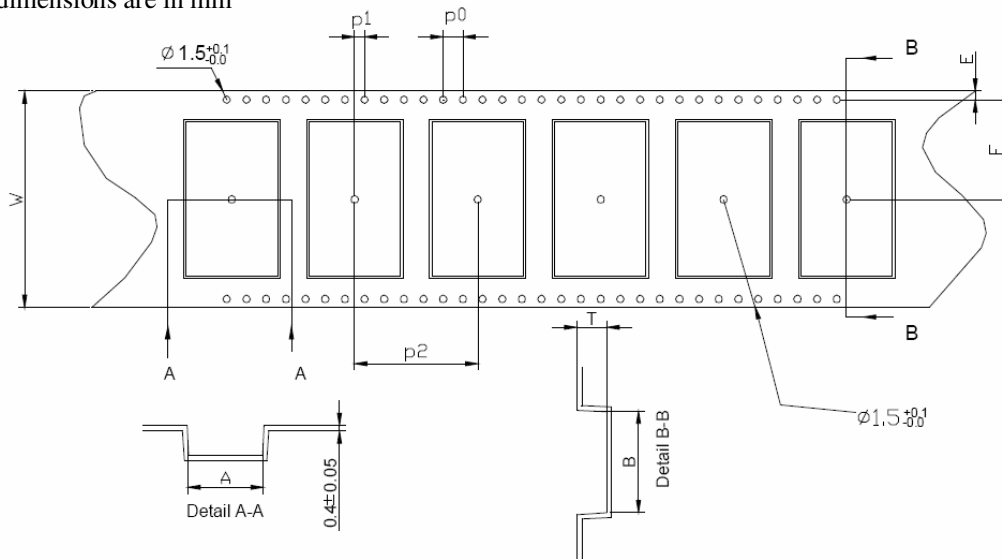

Module type	A	B	W	F	E	P0	P1	P2	T	Cover Tape width (W)
MD-120FA-5139A	18.5	40.9	56	26.2	1.75	4.0	2.0	24.0	3.4	49.5
Tolerance	±0.1	±0.1	±0.3	±0.1	+0.1	±0.1	±0.1	±0.1	±0.1	±0.1

**4.4.2 Cover tape details**

Thickness (T)	0.061mm
Surface resistivity (component side)	$10^4$ to $10^7$ Ohms/sq
Surface resistivity (component side)	Non-conductive
Backing type	Polyester
Adhesive type	PSA
Sealing	Room ambient

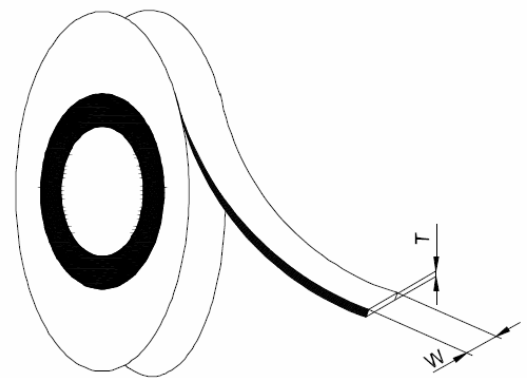

**4.4.3 Leader and Trailer**

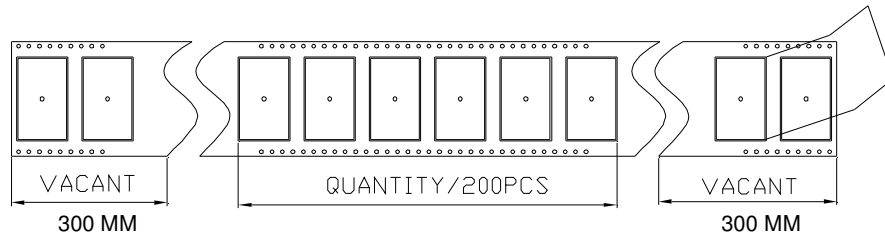

**4.4.4 Reel Dimensions**

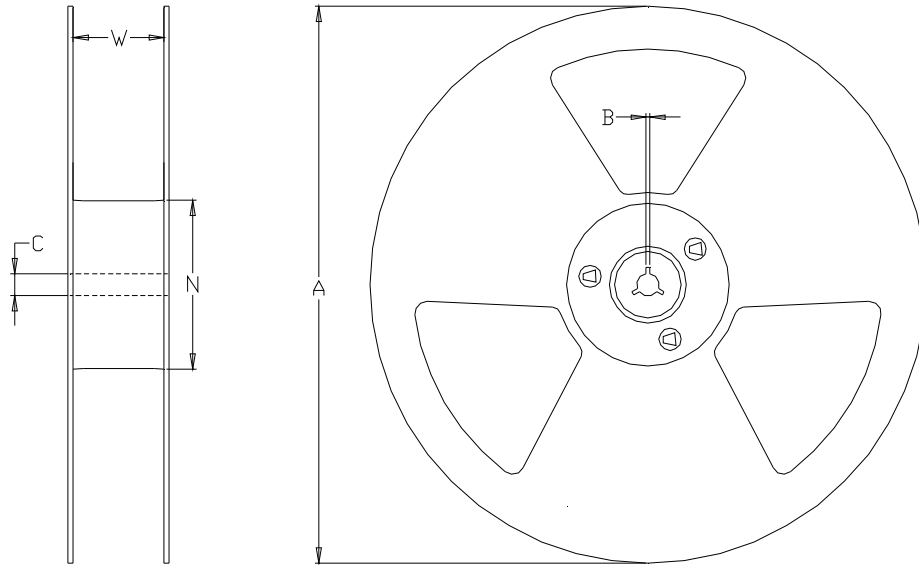

Module type:	A	B	C	N	W (min)
MD-120FA-5139A	330 ±1.0	2.2±0.5	13 ±0.2	100 +0.1	55.5 ±0.3

#### 4.5 SMT IR Profile

Average ramp-up rate (217C to peak): 3 °C /sec. max.

Preheat : 150~200 °C 、 60~180 seconds

Temperature maintained above 217 oC : 60~150 seconds

Time within 5 °C of actual peak temperature: 20 ~ 40 sec.

Peak temperature : 250+0/-5 °C

Ramp-down rate : 6 °C/sec. max.

Time 25 °C to peak temperature : 8 minutes max.

Cycle interval : 5 minus

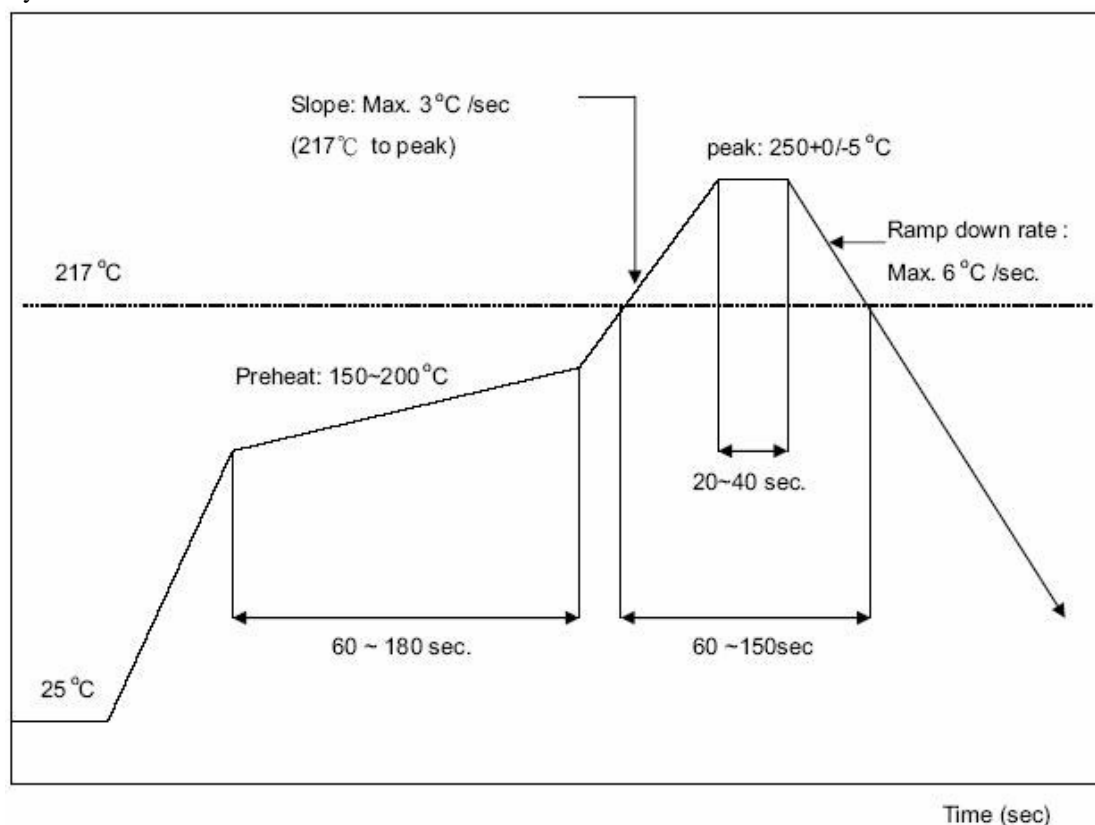

#### 4.6 How to Avoid ESD Damage to ICs

- \* Any person handling the ICs should be grounded either with a wrist strap or ESD-protective footwear used in conjunction with a conductive or static-dissipative floor or floor mat.
- \* The work surface where devices are placed for handling, processing, testing, etc., must be made of static-dissipative material and be grounded to ESD ground.
- \* All insulator materials must either be removed from the work area or must be neutralized with an ionizer. Static-generating clothing must be covered with an ESD-protective smock.
- \* When ICs are being stored, transferred between operations or workstations, or shipped, they must be kept in a Faraday shield container with inside surfaces (surfaces touching the ICs) that are static-dissipative.

## 5. FCC Statement

### **Federal Communication Commission Interference Statement**

This equipment has been tested and found to comply with the limits for a Class B digital device, pursuant to Part 15 of the FCC Rules. These limits are designed to provide reasonable protection against harmful interference in a residential installation. This equipment generates, uses and can radiate radio frequency energy and, if not installed and used in accordance with the instructions, may cause harmful interference to radio communications. However, there is no guarantee that interference will not occur in a particular installation. If this equipment does cause harmful interference to radio or television reception, which can be determined by turning the equipment off and on, the user is encouraged to try to correct the interference by one of the following measures:

- Reorient or relocate the receiving antenna.
- Increase the separation between the equipment and receiver.
- Connect the equipment into an outlet on a circuit different from that to which the receiver is connected.
- Consult the dealer or an experienced radio/TV technician for help.

FCC Caution: Any changes or modifications not expressly approved by the party responsible for compliance could void the user's authority to operate this equipment.

This device complies with Part 15 of the FCC Rules. Operation is subject to the following two conditions: (1) This device may not cause harmful interference, and (2) this device must accept any interference received, including interference that may cause undesired operation.

This device and its antenna(s) must not be co-located or operation in conjunction with any other antenna or transmitter.

### **IMPORTANT NOTE:**

#### **FCC Radiation Exposure Statement:**

This equipment complies with FCC radiation exposure limits set forth for an uncontrolled environment. This equipment should be installed and operated with minimum distance 20cm between the radiator & your body.

### **IMPORTANT NOTE:**

This module is intended for OEM integrator. The OEM integrator is still responsible for the FCC compliance requirement of the end product, which integrates this module.

20cm minimum distance has to be able to be maintained between the antenna and the users for the host this module is integrated into. Under such configuration, the FCC radiation exposure limits set forth for a population/uncontrolled environment can be satisfied.

Any changes or modifications not expressly approved by the manufacturer could void the user's authority to operate this equipment.

**USERS MANUAL OF THE END PRODUCT:**

In the users manual of the end product, the end user has to be informed to keep at least 20cm separation with the antenna while this end product is installed and operated. The end user has to be informed that the FCC radio-frequency exposure guidelines for an uncontrolled environment can be satisfied. The end user has to also be informed that any changes or modifications not expressly approved by the manufacturer could void the user's authority to operate this equipment. If the size of the end product is smaller than 8x10cm, then additional FCC part 15.19 statement is required to be available in the users manual: This device complies with Part 15 of FCC rules. Operation is subject to the following two conditions: (1) this device may not cause harmful interference and (2) this device must accept any interference received, including interference that may cause undesired operation.

**LABEL OF THE END PRODUCT:**

The final end product must be labeled in a visible area with the following " Contains TX FCC ID: XNNMD120FA ". If the size of the end product is larger than 8x10cm, then the following FCC part 15.19 statement has to also be available on the label: This device complies with Part 15 of FCC rules. Operation is subject to the following two conditions: (1) this device may not cause harmful interference and (2) this device must accept any interference received, including interference that may cause undesired operation.

## **6. IC Statement**

**This Class B digital apparatus complies with Canadian ICES-003.**

Operation is subject to the following two conditions: (1) this device may not cause interference, and (2) this device must accept any interference, including interference that may cause undesired operation of the device.

Cet appareil numérique de la classe B est conforme à la norme NMB-003 du Canada.

This device and its antenna(s) must not be co-located or operation in conjunction with any other antenna or transmitter.

The device could automatically discontinue transmission in case of absence of information to transmit, or operational failure. Note that this is not intended to prohibit transmission of control or signaling information or the use of repetitive codes where required by the technology.

### **IMPORTANT NOTE:**

#### **IC Radiation Exposure Statement:**

This equipment complies with IC RSS-102 radiation exposure limits set forth for an uncontrolled environment. This equipment should be installed and operated with minimum distance 20cm between the radiator & your body.

This module is intended for OEM integrator. The OEM integrator is still responsible for the IC compliance requirement of the end product, which integrates this module.

20cm minimum distance has to be able to be maintained between the antenna and the users for the host this module is integrated into. Under such configuration, the IC RSS-102 radiation exposure limits set forth for a population/uncontrolled environment can be satisfied.

Any changes or modifications not expressly approved by the manufacturer could void the user's authority to operate this equipment.



**USERS MANUAL OF THE END PRODUCT:**

In the users manual of the end product, the end user has to be informed to keep at least 20cm separation with the antenna while this end product is installed and operated. The end user has to be informed that the IC radio-frequency exposure guidelines for an uncontrolled environment can be satisfied. The end user has to also be informed that any changes or modifications not expressly approved by the manufacturer could void the user's authority to operate this equipment. IC statement is required to be available in the users manual: This Class B digital apparatus complies with Canadian ICES-003. Operation is subject to the following two conditions: (1) this device may not cause harmful interference and (2) this device must accept any interference received, including interference that may cause undesired operation.

**LABEL OF THE END PRODUCT:**

The final end product must be labeled in a visible area with the following " Contains TX IC : 8520A-MD120FA ".

## **7. Contact Information**

### **Headquarter(Taiwan)**

**JOYMAX ELECTRONICS CO., LTD.**

No. 5, Dong Yuan Rd.2,  
Jhongli Industrial Park,  
Jhongli City, Taoyuan 32063,  
Taiwan, R.O.C.

Tel: +886-3-433-5698

Fax: +886-3-433-5798

E-mail: [info@joymax.com.tw](mailto:info@joymax.com.tw)

website: <http://www.joymax.com.tw>

<http://www.joymax-antenna.com>

### **Europe**

**Joymax Europe GmbH**

Buettgenbachstr. 10  
D-40549 Duesseldorf  
Germany

Tel : 49-211-984 937

Fax : 49-211-984 9399

E-mail : [info@joymax.de](mailto:info@joymax.de)

<http://www.joymax.de>

### **U.S.A.**

**Nearson Inc.**

7432 Alban Station Blvd. Suite B226  
Springfield, VA 22150  
U.S.A.

Tel : 1-703-9135552

Fax : 1-703-9135553

E-mail : [sales@nearson.com](mailto:sales@nearson.com)

<http://www.nearson.com>