

# User's Manual

**Model No.: CCD-640**

## **2.4GHz WIRELESS CAMERA OBSERVATION SYSTEM WITH REMOTE CONTROL**

- Wireless Color Weatherproof Cameras
- 2.4GHz Wireless A/V Receiver

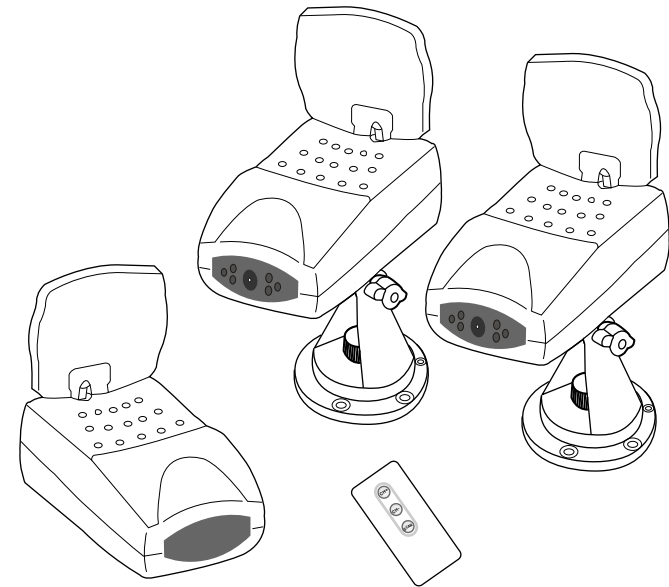

### **PLEASE READ CAREFULLY AND SAVE**

This manual contains important information about this product's operation. If you are installing this product for others, you must leave this manual -or a copy- with the end user.

## **Important!**

**Please read this Manual carefully  
before installing or using these units.**

**WARNING-** These units should ONLY be disassembled by an authorized technician if service is required.

### **Safety Precautions**

For correct and safe operation of this system, it is essential that installers, end-users and service technicians should follow all safety procedures outlined in this manual. Specific Warning and Caution statements (and/or symbols) are marked on the units where needed.

### **Warning and Caution Statements**

"WARNING" indicates a situation where failure to follow proper procedures can cause personal injury.

"CAUTION" indicates a situation where failure to follow proper procedures can cause damage to the equipment.

This camera is subject to interference from cordless phones, microwaves, and other wireless devices operating in the 2.4GHz range. Keep the system AT LEAST 10 ft away from the devices during installation and operation.

If the camera system no longer functions respectively can no longer be repaired, it must be disposed of according to the valid statutory regulations.

Disposal of spent batteries / accumulators



You are required by law (**Battery Ordinance**) to return all spent batteries and accumulators. **Disposing of spent batteries/accumulators in the household waste is prohibited!** Batteries / accumulators that contain hazardous substances are marked with the symbols on the side. These symbols indicate that it is prohibited to dispose of these batteries/accumulators in the household waste. The abbreviations for the respective heavy metal are: **Cd**= cadmium, **Hg**= mercury, **Pb**= lead. You can return spent batteries respectively accumulators that can no longer be charged free of charge to the collection points in your community, our outlets or everywhere else where batteries or accumulators are sold.

**You thus fulfill the legal requirements and contribute to the protection of our environment!**

## Troubleshooting

With this camera system, you have purchased a product that reflects the latest state of technology and is safe to operate. Still there might be problems or malfunctions. At this point, we want to tell you how to easily remedy possible malfunctions yourself.



**Observe the safety notices under all circumstances!**

Error	Possible cause
No image and no sound	<ul style="list-style-type: none"> <li>• Camera or receiver are not supplied with electricity.</li> <li>• Is the power pack plugged in correctly.</li> <li>• The distance between the camera and receiver is too far.</li> </ul>
The image/sound is distorted	<ul style="list-style-type: none"> <li>• The range of the system was exceeded. Shorten the distance.</li> <li>• There is a strong interference source (e.g. electric engine, walkie-talkie, etc.) nearby.</li> <li>• The distance between the camera and the receiver is too short; this may over steer the receiver. Extend the distance.</li> <li>• The supply voltage is too low</li> </ul>
Flickering/running image	<ul style="list-style-type: none"> <li>• Strong spotlight in the cover range of the camera.</li> </ul>
Normal sound, image is too light or dark.	<ul style="list-style-type: none"> <li>• Surveillance monitor (TV) is adjusted wrongly (readjust contrast and brightness).</li> <li>• Strong spotlight in the cover range of the camera.</li> </ul>
White image only on the monitor.	<ul style="list-style-type: none"> <li>• The surveillance monitor (TV) is not correctly adjusted ( brightness controller).</li> </ul>



Other repairs as described above may only be performed by an authorised workshop.

## Contents

<b>Safety and Hazard Notices</b> .....	<b>1.</b>
<b>FCC/CE WARNING</b> .....	<b>3.</b>
<b>Parts Included in This System</b> .....	<b>3.</b>
<b>Installing the Camera</b> .....	<b>4.</b>
<b>Installing the Receiver</b> .....	<b>5.</b>
<b>System Installation</b> .....	<b>6.</b>
<b>Technical Data</b> .....	<b>7.</b>
<b>Maintenance</b> .....	<b>7.</b>
<b>Disposal</b> .....	<b>8.</b>
<b>Troubleshooting</b> .....	<b>8.</b>

## Safety and Hazard Notices



**Damages caused by non-compliance with this operating manual lead to the expiration of the warranty! We will not assume any liability for subsequent damages! We will not assume any liability for damages to items or persons caused by improper handling or non-compliance with the safety notices! Any warranty claim will be null and void in such cases.**

- This product has left the factory in perfectly safety condition. In order to maintain this status and ensure safe operation, the user has to observe the safety notices and warnings ("Attention!" and "Notice!") contained in this operating manual.

## The following symbols need to be observed:



= An exclamation mark in a triangle indicates important notices in these operating instructions that must be observed under all circumstances.



= A lightning symbol warns of electric shock or the impairment of the appliance's electric safety.

- You may only use a (100V~240 Volt / 50 Hz or 60 Hz) socket of the public supply net for the supply of the power packs. Never attempt to operate the appliances with a different voltage.
- Make sure that all electric connections and connection cables between the devices of the camera system as well as the devices to be connected meet the pertaining regulations and are in conformity with the operating instructions.
- In commercial institutions, make sure you observe the accident prevention regulations of the commercial trade organisation for electric installations.
- In schools, training facilities, hobby and self-help workshops, qualified personnel needs to supervise the operation of electronic devices.
- Also observe the safety notices and operating instructions of the other appliances connected to the system.
- Please contact an expert in case you have any doubts about the mode of operation, the safety or connecting the appliances.
- Do not operate the devices unsupervised.
- When opening the covers or removing parts except where possible by hand, you may expose live parts. Connections may also be live. Prior to aligning, cleaning, service or repair work or exchanging parts or modules, you must separate the appliances from all power sources if you need to open them. Only an expert familiar with the risks and the pertinent regulations may repair or maintain an open live appliance.
- Never plug-in or unplug the power packs with wet hands.
- Never tug on the power chords of the power packs, use the plug to unplug it from the wall socket.
- Always unplug the power packs from the wall outlet during thunder storms.
- Make sure that the power cables do not get squashed or damaged by sharp edges when installing the devices.
- Never replace damaged power cables yourself! In such a case, remove them from the net and take the devices to a workshop.

## Technical Data

	Camera	Receiver
Operating voltage	7.5V DC	7.5V DC
Current consumption	300 mA	300 mA
Transmitting frequency	2.4-2.4835Ghz	2.4-2.4835Ghz
Modulation	FM	
Channels	4	4
Video output level		1 Vp-p / 75 Ohm
Audio output level, mono		1 Vp-p / 600Ohm
Audio/Video Connection jacks		AV jack
Picture sensor	1/3" CMOS color 628x562 pixel (PAL) or 510x492 (NTSC)	
Resolution	330 TV lines (horizontal),	
Microphone	mono	
Picture	Color	
Range	approx 100 m at free visibility	
Operating temperature	14 to 122°F/ -10°C to +50°C	
Mass approx. (without tripod)	209g	209g
Dimensions without Aerial	95 x 47x 63 (mm) L x W x H	95 x 47 x 63 (mm) L x W x H

### Plug-in power units

Operating voltage	100~240V / 60 or 50Hz	100~240V / 60 or 50Hz
Output voltage	7.5V DC / 300mA	7.5V DC / 300mA

## Maintenance

The devices are maintenance-free, so never disassemble them. The guarantee becomes void when you open the appliance. Only clean the outside of the devices with a soft, dry cloth or a brush. Prior to cleaning, remove the devices from all voltage sources.



Do not use any carboxylic cleaning agents or petrol, alcohol or similar. These attack the surfaces of the devices. Besides, the vapors are hazardous to your health and explosive. Do not use any sharp edged tools, screw drivers, metal brushes or similar for cleaning.

# System Installation

When installing the camera, check the reception of the receiver before final installation. Have someone hold the camera in the area to be monitored. Have another person move the receiver to a variety of locations throughout the house to check reception. If interference or other problems occur, refer to the Troubleshooting Guide.

## To install the system, follow these steps:

- Select the same channel to be used on both the camera and receiver.

### Channel selection on the camera

The camera can be set up in four different optional channels. To set the channel, use a pointed object, e.g. a ballpoint pen, to select the desired channel to position on CH1, CH2, CH3 and CH4. Only one channel is activated on one camera.

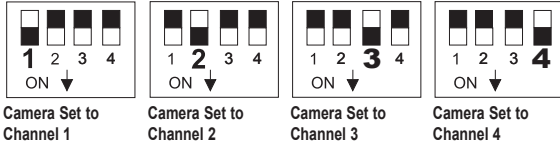

### Channel selection on the receiver

The receiver can receive up to four different channels and detect the available signals from each camera. To switch between the channels and operate the auto scan function, it is only operated on the remote control (please see the operation of the remote control on page 5).

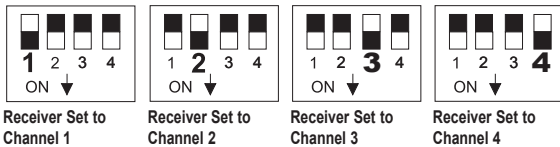

### Notice:

1. Two cameras are preset to CH1 and CH3 from factory.
2. Either one camera is plug in the system, the system presets to CH1 by default on the screen.
3. No matter how many channels on the receiver are turned on; the receiver will lock on the cameras as a still image. And, the auto scan mode will only operates with the remote control.

## Rotating the Antenna for Best Performance

This system broadcasts its high-quality audio and video using directional antenna. The antenna can rotate in either clockwise or counterclockwise directions to obtain the best signal and picture clarity. In most situations, additional adjusting of the antenna may be necessary to get optimal performance. If the camera and receiver are less than 10 feet apart, leave the antenna in the closed (down) position. See the instructions shown on the right to rotate the antenna.

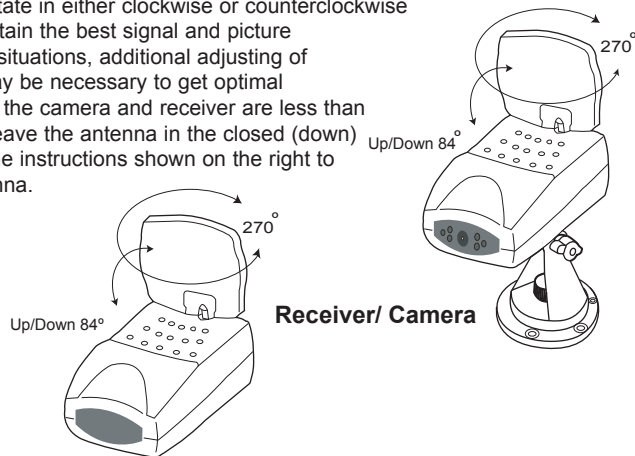

## FCC/CE WARNING

This equipment generates and uses radio frequency energy and if not installed and used properly, that is, in strict accordance with the manufacture's instructions, may cause interference to radio and television reception. It has been tested and found to comply with limits for a Class B digital device in accordance with Part 15 of FCC Rules and CE I-ETS 300 440, which are designed to provide reasonable protection against such interference in a residential installation. However, there is no guarantee that interference will not occur in a particular installation. If this equipment does cause interference to radio or television reception, which can be determined by turning the equipment off and on, the user is encouraged to try to correct the interference by one or more of the following measures:

1. Reorient the TV/radio antenna.
2. Relocate the Receiver away from the TV/radio receiver.
3. Plug the Receiver into a different wall outlet so that the Receiver is on a different branch circuit.
4. If necessary, the user should consult the dealer or an experienced radio/television technician for additional suggestions.

The user may find the following booklet prepared by the Federal Communication Commission helpful: "How to Identify and Resolve TV Interference Problems." This booklet is available from the US Government Printing Office, Washington, D.C. 20402, Stock No. 004-000-00345-4.

### FCC/CE NOTICE

The user is cautioned that changes or modifications not expressly approved by the manufacturer could void the user's authority to operate the equipment. Linear radio controls provide a reliable communications link and fill an important need in portable wireless signaling. However, there are some limitations which must be observed. The radios are required to comply with FCC Rules and Regulations as Part 15 devices and CE I-ETS 300 440. As such, they have limited transmitter power and therefore limited range. A receiver cannot respond to more than one transmitted signal at a time and may be blocked by radio signals that occur on or near their operating frequencies. Changes or modifications to the device may void FCC and CE compliance. Infrequently used radio links should be tested regularly to protect against undetected interference or fault.

## Parts Included in This System

1. 2.4 GHz Wireless color camera x2
2. 2.4 GHz Wireless receiver x1
3. 7.5V AC/DC Adaptor for the camera x2
4. 7.5V AC/DC Adaptor for the receiver x1
5. Camera bracket x 2
6. A/V Cable x1
7. Remote Control x1

## Installing the Camera



### ATTENTION!

Prior to drilling and inserting the screws, make sure that there are no electric cable pipes, etc. in the wall that may become damaged.

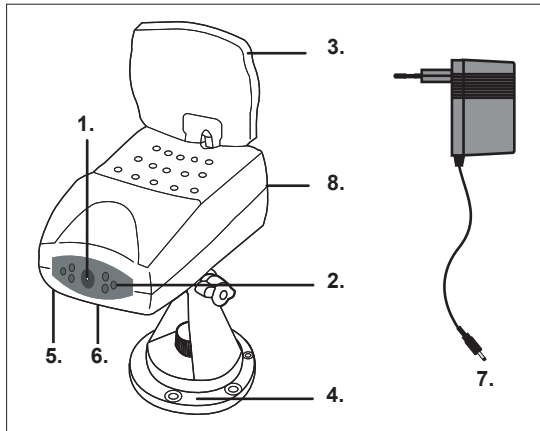

1. Camera Lens
2. 6 pcs IR LED
3. Antenna
4. Camera Stand
5. Microphone
6. Channel Switch
7. Power adaptor
8. Power LED

## Installing and Connecting the Devices

Select a suitable installation site from which you want to monitor the desired object.

A suitable installation site has the following features:

- dry
- as dust-free as possible
- little vibrations
- good air circulation
- with a power outlet in close vicinity

☞ Select an installation site that is not screened off by reinforced concrete walls, mirrors, metal shelves, etc. There should not be any appliances with strong electric fields close to the sender and receiver.

Any strong electric environment could cause the interference and reduce the performance

### Fastening the wall bracket

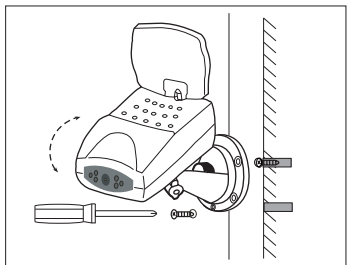

- Look for a suitable place for mounting (with a socket close-by)
- Screw the wall bracket with the supplied screws to a suitable wall or a suitable platform, use dowels if relevant.

## Connecting the camera

Connect the low voltage plug of the power unit to the voltage supply jack of the camera. Pay attention to the correct input voltage of 7.5V DC!

- Insert the plug-in power unit into a suitable mains socket.
- The camera is now ready for use.

4.

## Installing the Receiver

Set up the receiver approx. 1 m above ground (better receiving condition). There must be a power outlet in proximity to the receiving site.



### ATTENTION!

Only place the receiver on rugged and stable surfaces. Sensitive surfaces or surfaces that dissolve softeners may become damaged. Use a suitable underlay.

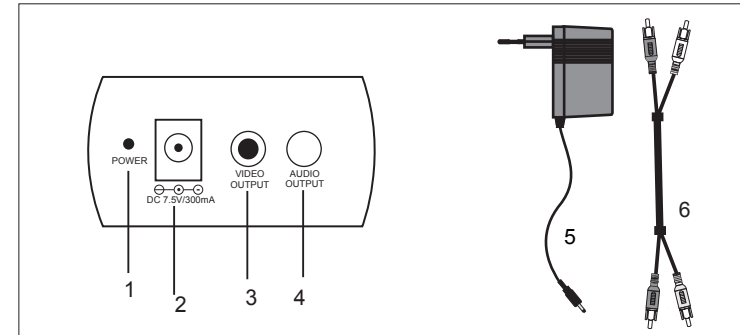

1. Power LED
2. Power plug
3. Video Output
4. Audio Output

5. Power supply
6. A/V cable

## Parts of the Remote Control

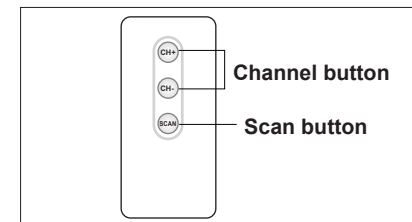

## Remote Control Operation

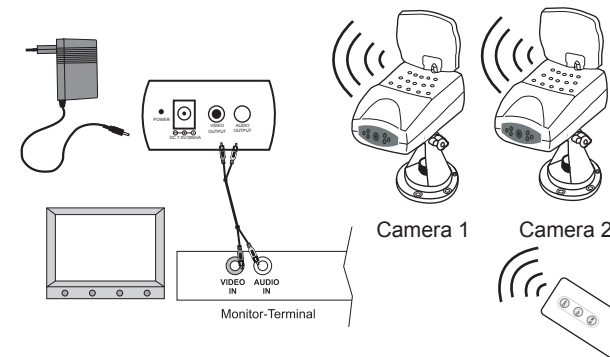

1. Camera 1 image set as default image.
2. By press the CH+ button to view the next camera image.
3. By press the CH- button to go back the camera image.
4. By press the Auto Scan button to scan two cameras image with 5 sec intervals repeatedly.
5. Make sure you are within InfraRed valid distance (2m/ 6feet) and 30 degree receiving angle from receiver.

### Notice:

1. Camera 1 is preset to CH1
2. Camera 2 is preset to CH3

5.