

ENGLISH

Thank you for purchasing a JVC product.

Installation

Warning

- Avoid installing the adapter unit in the following places.
 - Where they would hinder your safety driving.
 - Where they would be exposed to direct sunlight or heat directly from the heater or placed in an extremely hot place.
 - Where they would be subject to rain, water splashes or excessive humidity.
 - Where they would be subject to dust.
 - Where they would be positioned on an unstable place.
 - Where they could damage the car's fittings.
 - Where radio wave interferes (EX.: trunk, etc.)

Mounting the adapter unit

Wipe clean the selected surface sufficiently, and affix the Double-sided tape. (refer to Fig A)

Connection

(refer to Fig B)

ESPAÑOL

Thank you for purchasing a JVC product.

Installation

Warning

- Avoid installing the adapter unit in the following places.
 - Where they would hinder your safety driving.
 - Where they would be exposed to direct sunlight or heat directly from the heater or placed in an extremely hot place.
 - Where they would be subject to rain, water splashes or excessive humidity.
 - Where they would be subject to dust.
 - Where they would be positioned on an unstable place.
 - Where they could damage the car's fittings.
 - Where radio wave interferes (EX.: trunk, etc.)

Mounting the adapter unit

Wipe clean the selected surface sufficiently, and affix the Double-sided tape. (refer to Fig A)

Connection

(refer to Fig B)

FRANÇAIS

Thank you for purchasing a JVC product.

Installation

Warning

- Avoid installing the adapter unit in the following places.
 - Where they would hinder your safety driving.
 - Where they would be exposed to direct sunlight or heat directly from the heater or placed in an extremely hot place.
 - Where they would be subject to rain, water splashes or excessive humidity.
 - Where they would be subject to dust.
 - Where they would be positioned on an unstable place.
 - Where they could damage the car's fittings.
 - Where radio wave interferes (EX.: trunk, etc.)

Mounting the adapter unit

Wipe clean the selected surface sufficiently, and affix the Double-sided tape. (refer to Fig A)

Connection

(refer to Fig B)

DEUTSCH

Thank you for purchasing a JVC product.

Installation

Warning

- Avoid installing the adapter unit in the following places.
 - Where they would hinder your safety driving.
 - Where they would be exposed to direct sunlight or heat directly from the heater or placed in an extremely hot place.
 - Where they would be subject to rain, water splashes or excessive humidity.
 - Where they would be subject to dust.
 - Where they would be positioned on an unstable place.
 - Where they could damage the car's fittings.
 - Where radio wave interferes (EX.: trunk, etc.)

Mounting the adapter unit

Wipe clean the selected surface sufficiently, and affix the Double-sided tape. (refer to Fig A)

Connection

(refer to Fig B)

ITALIANO

Thank you for purchasing a JVC product.

Installation

Warning

- Avoid installing the adapter unit in the following places.
 - Where they would hinder your safety driving.
 - Where they would be exposed to direct sunlight or heat directly from the heater or placed in an extremely hot place.
 - Where they would be subject to rain, water splashes or excessive humidity.
 - Where they would be subject to dust.
 - Where they would be positioned on an unstable place.
 - Where they could damage the car's fittings.
 - Where radio wave interferes (EX.: trunk, etc.)

Mounting the adapter unit

Wipe clean the selected surface sufficiently, and affix the Double-sided tape. (refer to Fig A)

Connection

(refer to Fig B)

PORTUGUÊS

Thank you for purchasing a JVC product.

Installation

Warning

- Avoid installing the adapter unit in the following places.
 - Where they would hinder your safety driving.
 - Where they would be exposed to direct sunlight or heat directly from the heater or placed in an extremely hot place.
 - Where they would be subject to rain, water splashes or excessive humidity.
 - Where they would be subject to dust.
 - Where they would be positioned on an unstable place.
 - Where they could damage the car's fittings.
 - Where radio wave interferes (EX.: trunk, etc.)

Mounting the adapter unit

Wipe clean the selected surface sufficiently, and affix the Double-sided tape. (refer to Fig A)

Connection

(refer to Fig B)

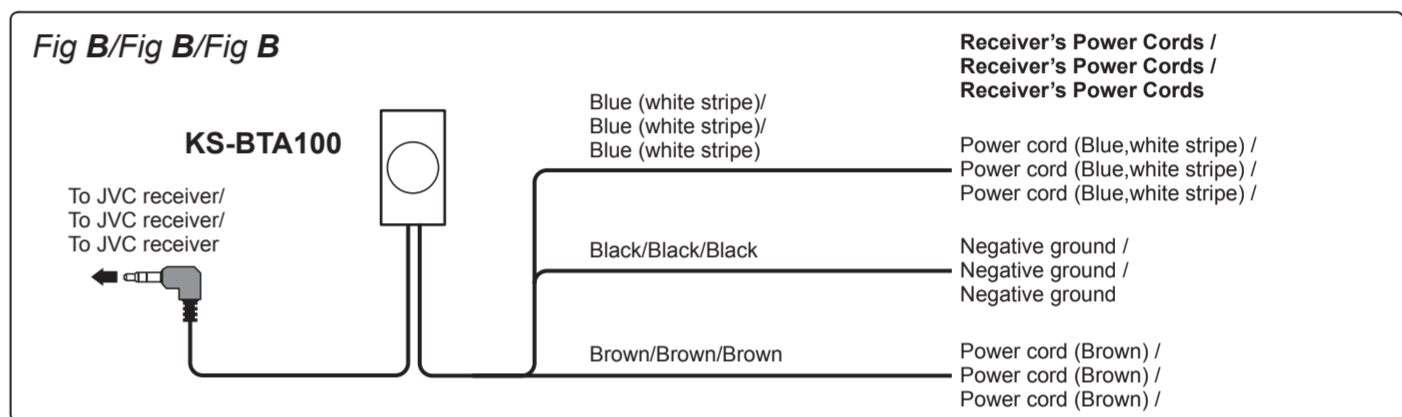
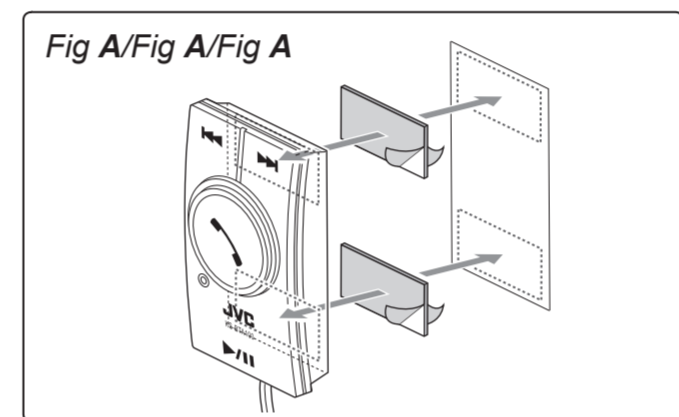
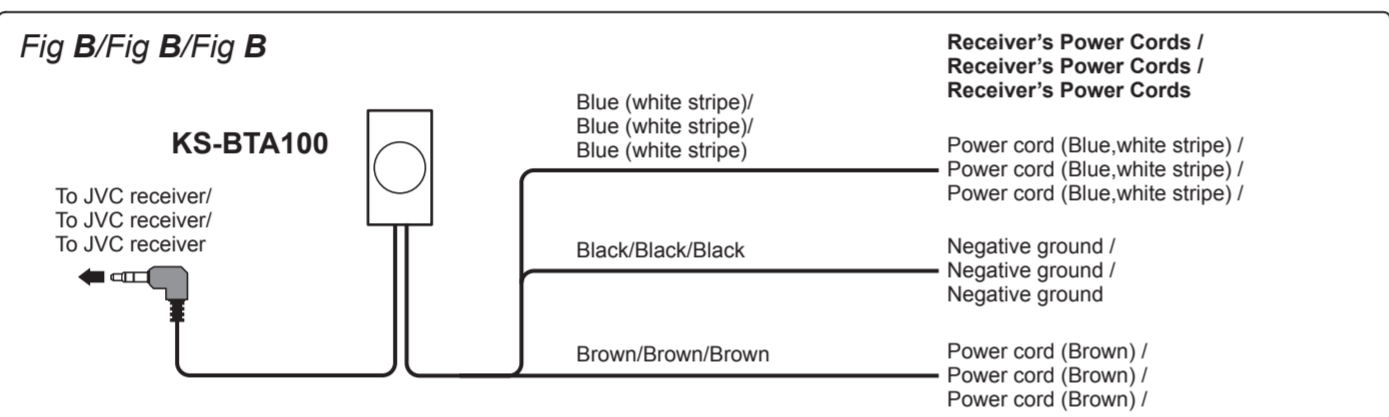
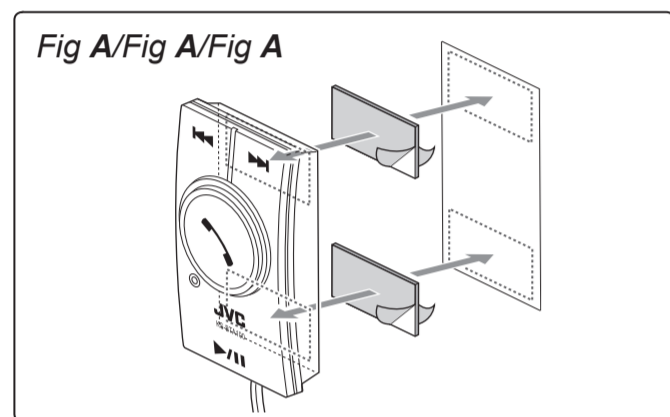

Using the Bluetooth device

Warning

Stop the car before operating the unit.

Caution

Operations may be different according to the connected device.

Registration of the Bluetooth device

Register (pair) a Bluetooth device

- 1 [Hold this button for 5 seconds.]
A play/pause button flashes on and off.

2 Search the KS-BTA100 from your device.

- 3 If a PIN code is required, enter "0000".
(It is not necessary for some mobile phones.)
When registration is completed, a play/pause button lights up.

Using the Bluetooth mobile phone

- Receiving a call
When a call comes in...
- Making a call (Redial)
Making a call to the last connected number from your phone.
- Switching between handsfree and phone
While talking...

Adjusting the microphone volume
Volume level: High/ Normal (initial)/ Low



- Ends/rejects call
- Voice dialing
Voice dialing is available only when the connected mobile phone has the voice recognition system.

- Delete all registered devices from the list.
[Hold the two buttons at the same time for about 10 seconds.]

Using the Bluetooth audio system

- [Press] Selects track.
- [Hold] Fast-forwards or reverses the track.

- [Press] Play/Pause
- [Hold] Stop

Using the Bluetooth device

Warning

Stop the car before operating the unit.

Caution

Operations may be different according to the connected device.

Registration of the Bluetooth device

Register (pair) a Bluetooth device

- 1 [Hold this button for 5 seconds.]
A play/pause button flashes on and off.

2 Search the KS-BTA100 from your device.

- 3 If a PIN code is required, enter "0000".
(It is not necessary for some mobile phones.)
When registration is completed, a play/pause button lights up.

Using the Bluetooth mobile phone

- Receiving a call
When a call comes in...
- Making a call (Redial)
Making a call to the last connected number from your phone.
- Switching between handsfree and phone
While talking...

Adjusting the microphone volume
Volume level: High/ Normal (initial)/ Low



- Ends/rejects call
- Voice dialing
Voice dialing is available only when the connected mobile phone has the voice recognition system.

- Delete all registered devices from the list.
[Hold the two buttons at the same time for about 10 seconds.]

Using the Bluetooth audio system

- [Press] Selects track.
- [Hold] Fast-forwards or reverses the track.

- [Press] Play/Pause
- [Hold] Stop

Using the Bluetooth device

Warning

Stop the car before operating the unit.

Caution

Operations may be different according to the connected device.

Registration of the Bluetooth device

Register (pair) a Bluetooth device

- 1 [Hold this button for 5 seconds.]
A play/pause button flashes on and off.

2 Search the KS-BTA100 from your device.

- 3 If a PIN code is required, enter "0000".
(It is not necessary for some mobile phones.)
When registration is completed, a play/pause button lights up.

Using the Bluetooth mobile phone

- Receiving a call
When a call comes in...
- Making a call (Redial)
Making a call to the last connected number from your phone.
- Switching between handsfree and phone
While talking...

Adjusting the microphone volume
Volume level: High/ Normal (initial)/ Low



- Ends/rejects call
- Voice dialing
Voice dialing is available only when the connected mobile phone has the voice recognition system.

- Delete all registered devices from the list.
[Hold the two buttons at the same time for about 10 seconds.]

Using the Bluetooth audio system

- [Press] Selects track.
- [Hold] Fast-forwards or reverses the track.

- [Press] Play/Pause
- [Hold] Stop

Using the Bluetooth device

Warning

Stop the car before operating the unit.

Caution

Operations may be different according to the connected device.

Registration of the Bluetooth device

Register (pair) a Bluetooth device

- 1 [Hold this button for 5 seconds.]
A play/pause button flashes on and off.

2 Search the KS-BTA100 from your device.

- 3 If a PIN code is required, enter "0000".
(It is not necessary for some mobile phones.)
When registration is completed, a play/pause button lights up.

Using the Bluetooth mobile phone

- Receiving a call
When a call comes in...
- Making a call (Redial)
Making a call to the last connected number from your phone.
- Switching between handsfree and phone
While talking...

Adjusting the microphone volume
Volume level: High/ Normal (initial)/ Low



- Ends/rejects call
- Voice dialing
Voice dialing is available only when the connected mobile phone has the voice recognition system.

- Delete all registered devices from the list.
[Hold the two buttons at the same time for about 10 seconds.]

Using the Bluetooth audio system

- [Press] Selects track.
- [Hold] Fast-forwards or reverses the track.

- [Press] Play/Pause
- [Hold] Stop

Using the Bluetooth device

Warning

Stop the car before operating the unit.

Caution

Operations may be different according to the connected device.

Registration of the Bluetooth device

Register (pair) a Bluetooth device

- 1 [Hold this button for 5 seconds.]
A play/pause button flashes on and off.

2 Search the KS-BTA100 from your device.

- 3 If a PIN code is required, enter "0000".
(It is not necessary for some mobile phones.)
When registration is completed, a play/pause button lights up.

Using the Bluetooth mobile phone

- Receiving a call
When a call comes in...
- Making a call (Redial)
Making a call to the last connected number from your phone.
- Switching between handsfree and phone
While talking...

Adjusting the microphone volume
Volume level: High/ Normal (initial)/ Low



- Ends/rejects call
- Voice dialing
Voice dialing is available only when the connected mobile phone has the voice recognition system.

- Delete all registered devices from the list.
[Hold the two buttons at the same time for about 10 seconds.]

Using the Bluetooth audio system

- [Press] Selects track.
- [Hold] Fast-forwards or reverses the track.

- [Press] Play/Pause
- [Hold] Stop

Using the Bluetooth device

Warning

Stop the car before operating the unit.

Caution

Operations may be different according to the connected device.

Registration of the Bluetooth device

Register (pair) a Bluetooth device

- 1 [Hold this button for 5 seconds.]
A play/pause button flashes on and off.

2 Search the KS-BTA100 from your device.

- 3 If a PIN code is required, enter "0000".
(It is not necessary for some mobile phones.)
When registration is completed, a play/pause button lights up.

Using the Bluetooth mobile phone

- Receiving a call
When a call comes in...
- Making a call (Redial)
Making a call to the last connected number from your phone.
- Switching between handsfree and phone
While talking...

Adjusting the microphone volume
Volume level: High/ Normal (initial)/ Low



- Ends/rejects call
- Voice dialing
Voice dialing is available only when the connected mobile phone has the voice recognition system.

- Delete all registered devices from the list.
[Hold the two buttons at the same time for about 10 seconds.]

Using the Bluetooth audio system

- [Press] Selects track.
- [Hold] Fast-forwards or reverses the track.

- [Press] Play/Pause
- [Hold] Stop