

JVC

E

INTRODUCTION

CONTROLS,
INDICATORS AND
CONNECTORS

PREPARATIONS

PREPARATIONS
FOR OPERATION

SETTING AND
ADJUSTMENTS
BEFORE SHOOTING

SHOOTING
OPERATION

PLAYBACK MODE

USING EXTERNAL
COMPONENTS

MENU SCREENS

FEATURES OF THE
CAMERA SECTION

OTHERS

HD CAMERA RECORDER

GY-HD250

INSTRUCTIONS

GY-HD251

HDV Mini DV

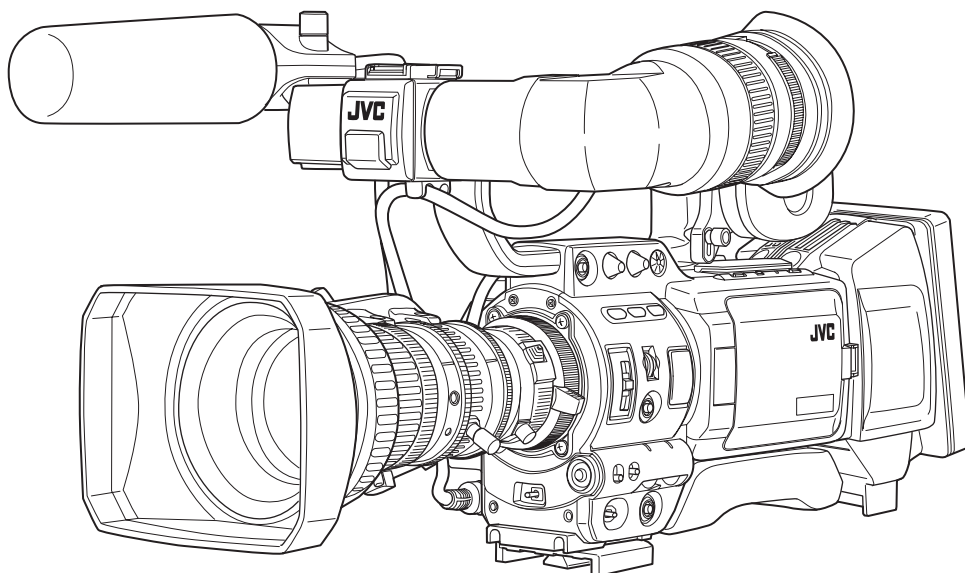

Thank you for purchasing this JVC product. Before operating this device, please read the instructions carefully to ensure the best possible performance.

For Customer Use:

Enter below the Serial No. which is located on the body.
Retain this information for future reference.
Model No.
Serial No.

* The illustration shows the GY-HD250/GY-HD251 HD CAMERA RECORDER with the provided lens, viewfinder and microphone attached.

Important Safeguards

1. Read all of these instructions.
2. Keep these instructions.
3. Heed all warnings.
4. Follow all instructions.
5. Do not use this apparatus near water.
6. Clean only with dry cloth.
7. Do not block any ventilation openings. Install in accordance with the manufacturer's instructions.
8. Do not install near any heat sources such as radiators, heat resisters, stoves, or other apparatus (including amplifiers) that produce heat.
9. Do not defeat the safety purpose of the polarized or grounding-type plug. A polarized plug has two blades with one wider than the other. A grounding type plug has two blades and a third grounding prong.

The wide blade or the third prong are provided for your safety.

If the provided plug does not fit into your outlet, consult an electrician for replacement of the obsolete outlet.

10. Protect the power cord from being walked on or pinched particularly at plug, convenience receptacles, and the point where they exit from the apparatus.
11. Only use attachments/accessories specified by the manufacturer.
12. Use only with the cart, stand, tripod, bracket, or table specified by the manufacturer, or sold with the apparatus.

PORTABLE CART WARNING
(symbol provided by RETAC)



S3125A

When a cart is used, use caution when moving the cart/apparatus combination to avoid injury tip-over.

13. Unplug this apparatus during lightning storms or when unused for long periods of time.
14. Refer all servicing to qualified service personnel. Servicing is required when the apparatus has been damaged in any way, such as power-supply cord or plug id damaged, liquid has been spilled objects have fallen into the apparatus, the apparatus has been exposed to rain or moisture, does not operate normally, or has been dropped.

Safety Precautions

FOR USA AND CANADA



CAUTION

RISK OF ELECTRIC SHOCK
DO NOT OPEN



CAUTION: TO REDUCE THE RISK OF ELECTRIC SHOCK, DO NOT REMOVE COVER (OR BACK). NO USER SERVICEABLE PARTS INSIDE. REFER SERVICING TO QUALIFIED SERVICE PERSONNEL.



The lightning flash with arrowhead symbol, within an equilateral triangle is intended to alert the user to the presence of uninsulated "dangerous voltage" within the product's enclosure that may be of sufficient magnitude to constitute a risk of electric shock to persons.



The exclamation point within an equilateral triangle is intended to alert the user to the presence of important operating and maintenance (servicing) instructions in the literature accompanying the appliance.

INFORMATION FOR USA

INFORMATION:

This equipment has been tested and found to comply with the limits for a Class B digital device, pursuant to Part 15 of the FCC Rules.

These limits are designed to provide reasonable protection against harmful interference in a residential installation. This equipment generates, uses, and can radiate radio frequency energy and, if not installed and used in accordance with the instructions, may cause harmful interference to radio communications. However, there is no guarantee that interference will not occur in a particular installation.

If this equipment does cause harmful interference to radio or television reception, which can be determined by turning the equipment off and on, the user is encouraged to try to correct the interference by one or more of the following measures:

- Reorient or relocate the receiving antenna.
- Increase the separation between the equipment and receiver.
- Connect the equipment into an outlet on a circuit different from that to which the receiver is connected.
- Consult the dealer or an experienced radio/TV technician for help.

CAUTION:

CHANGES OR MODIFICATIONS NOT APPROVED BY JVC COULD VOID USER'S AUTHORITY TO OPERATE THE EQUIPMENT.

THIS DEVICE COMPLIES WITH PART 15 OF THE FCC RULES.

OPERATION IS SUBJECT TO THE FOLLOWING TWO CONDITIONS: (1) THIS DEVICE MAY NOT CAUSE HARMFUL INTERFERENCE, AND (2) THIS DEVICE MUST ACCEPT ANY INTERFERENCE RECEIVED, INCLUDING INTERFERENCE THAT MAY CAUSE UNDESIRE OPERATION.

INFORMATION (FOR CANADA) RENSEIGNEMENT (POUR CANADA)

This Class B digital apparatus complies with Canadian ICES-003.

Cet appareil numérique de la Classe B est conforme à la norme NMB-003 du Canada.

WARNING:

TO REDUCE THE RISK OF FIRE OR ELECTRIC SHOCK, DO NOT EXPOSE THIS APPLIANCE TO RAIN OR MOISTURE.

This unit should be used with 12V DC only.

CAUTION:

To prevent electric shocks and fire hazards, do NOT use any other power source.

NOTE:

The rating plate (serial number plate) is on the bottom of the unit.

CAUTION:

To prevent electric shock, do not open the cabinet. No user serviceable parts inside. Refer servicing to qualified service personnel.

AVERTISSEMENT :

POUR EVITER LES RISQUES D'INCENDIE OU D'ELECTROCUTION, NE PAS EXPOSER L'APPAREIL A L'HUMIDITE OU A LA PLUIE.

Ce magnétoscope ne doit être utilisé que sur du courant direct en 12V.

ATTENTION :

Afin d'éviter tout resque d'incendie ou d'électrocution, ne pas utiliser d'autres sources d'alimentation électrique.

REMARQUE:

La plaque signalétique (plaque du numéro desérie) est située sur le cadre inférieur de l'unité.

Due to design modifications, data given in this instruction book are subject to possible change without prior notice.

The apparatus shall not be exposed to dripping or splashing and that no objects filled with liquids, such as vases, shall be placed close to the apparatus.

Worded - "CAUTION - Danger of explosion if battery is incorrectly replaced. Replace only with the same or equivalent type."

Safety Precautions (Cont'd)

FOR EUROPE

This equipment is in conformity with the provisions and protection requirements of the corresponding European Directives.

This equipment is designed for professional video appliances and can be used in the following environments:

- residential area (in houses)
- commercial and light industry; e.g. offices or theatres
- urban outdoors

In order to keep the best performance and furthermore for electro-magnetic compatibility we recommend to use cables not exceeding the following length:

Camera

Port	Cable	Length
DC IN	Exclusive Cable	2 m
VIDEO	Coaxial Cable	3 m
Y, PB, PR	Coaxial Cable	3 m
AUDIO INPUT1, INPUT2	Shielded Cable	3 m
AUDIO OUT CH1, CH2	Shielded Cable	3 m
Phones1, 2	Exclusive Cable	2 m
IEEE1394 (HDV/DV)	Exclusive Cable	4.5 m
GENLOCK/AUX IN	Coaxial Cable	3 m
HD/SD-SDI	Coaxial Cable	3 m
REMOTE	Exclusive Cable	5 m
STUDIO	Exclusive Cable	1 m

Caution: Where there are strong electromagnetic waves or magnetism, for example near a radio or TV transmitter, transformer, motor, etc., the picture and the sound may be disturbed. In such case, please keep the apparatus away from the sources of the disturbance.

Dear Customer,

This apparatus is in conformance with the valid European directives and standards regarding electromagnetic compatibility and electrical safety.

European representative of Victor Company of Japan Limited is:
JVC Technology Centre Europe GmbH
P.O. Box 10 05 52
61145 Friedberg
Germany

WARNING:

TO REDUCE THE RISK OF FIRE OR ELECTRIC SHOCK, DO NOT EXPOSE THIS APPLIANCE TO RAIN OR MOISTURE.

This unit should be used with 12V DC only.

CAUTION:

To prevent electric shocks and fire hazards, do NOT use any other power source.

NOTE:

The rating plate (serial number plate) is on the bottom of the unit.

CAUTION:

To prevent electric shock, do not open the cabinet. No user serviceable parts inside. Refer servicing to qualified service personnel.

Due to design modifications, data given in this instruction book are subject to possible change without prior notice.

The apparatus shall not be exposed to dripping or splashing and that no objects filled with liquids, such as vases, shall be placed close to the apparatus.

Worred - "CAUTION - Danger of explosion if battery is incorrectly replaced. Replace only with the same or equivalent type."

Information for Users on Disposal of Old Equipment

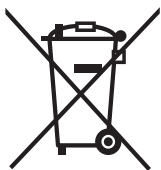

Attention:

This symbol is only valid in the European Union.

[European Union]

This symbol indicates that the electrical and electronic equipment should not be disposed as general household waste at its end-of-life. Instead, the product should be handed over to the applicable collection point for the recycling of electrical and electronic equipment for proper treatment, recovery and recycling in accordance with your national legislation.

By disposing of this product correctly, you will help to conserve natural resources and will help prevent potential negative effects on the environment and human health which could otherwise be caused by inappropriate waste handling of this product. For more information about collection point and recycling of this product, please contact your local municipal office, your household waste disposal service or the shop where you purchased the product.

Penalties may be applicable for incorrect disposal of this waste, in accordance with national legislation.

(Business users)

If you wish to dispose of this product, please visit our web page www.jvc-europe.com to obtain information about the take-back of the product.

[Other Countries outside the European Union]

If you wish to dispose of this product, please do so in accordance with applicable national legislation or other rules in your country for the treatment of old electrical and electronic equipment.

Thank you for purchasing the JVC GY-HD250U/CHU and GY-HD251E/CHE HD CAMERA RECORDER.

These instructions are for the GY-HD250U/CHU and GY-HD251E/CHE.

- A lens is included with the GY-HD250U and GY-HD251E.
- A lens is not included with the GY-HD250CHU and GY-HD251CHE.

Information applicable only to the GY-HD250U/CHU is marked by "(U model only)".

Information applicable only to the GY-HD251E/CHE is marked by "(E model only)".

HDV / Mini DV

This device is a HDV/DV video system format camera recorder.

Videocassettes marked with the Mini DV symbol can be used.

The following phenomena may occur when tapes recorded on other units (including another GY-HD250/GY-HD251) are recorded or played back on GY-HD250/GY-HD251.

- The transient section between scenes recorded on other units and those recorded on this device may appear disturbed.
- Digital noise may appear during playback due to tracking errors.

- This device records and plays back in the SP mode. Recording or playback in the LP mode is not possible. (In DV format)
- Due to manufacturing dispersion of tapes, we recommend not to record pictures within the first 2 to 3 minutes from the beginning of the tape.
- Before recording important scenes, be sure to perform a test recording and confirm that both video and audio are recorded correctly.
- Recorded video and audio contents are for private use. Other use may infringe on the rights of copyright holders.
- JVC cannot assume liabilities that may derive from the impossibility of normal recording or playback of video or audio due to malfunction of this device or the videocassette.

* All product names in this manual are trademarks or registered trademarks of their respective companies. Marks such as ™, ® and © are not used in this manual.

ACCESSORIES

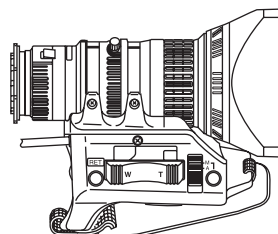

(Excluding the CHU/CHE model)

Lens

☞ See pages 10 and 33

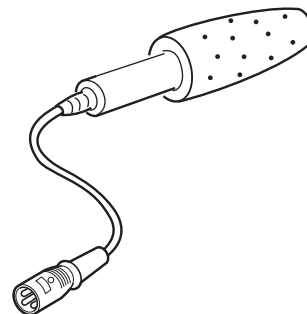

Microphone

☞ See page 33



Core Filter
For Viewfinder Cable

☞ See page 34

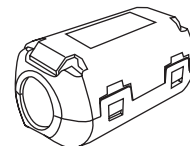

Clamp Filters ×4
For DC (×2)/Earphone/
IEEE1394 Cable

☞ See pages 12, 36 and 64

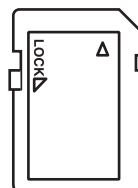

SD memory card

☞ See page 34

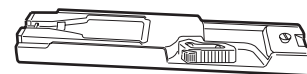

Tripod base
(Provided only for U model)

☞ See page 35

MAIN FEATURES

- GY-HD250/GY-HD251 records in HDV format or DV format. DV format can record and play back SD (Standard Definition) video on Mini DV videocassettes. HDV format can record and play back HD (High Definition) video on Mini DV videocassettes. There are two types of recording formats within HDV format. HDV 720p (720 effective scan lines, progressive scan) HDV 1080i (1080 effective scan lines, interlaced scan) GY-HD250/GY-HD251 supports HDV 720p format. (HDV 720p) HDV and **HDV** are trademarks of Sony Corporation and Victor Company of Japan, Limited.
- 24p mode shooting function
In HDV format, it records in 24p mode. It uses a 2:3:2:3 pulldown when recording to tape and converts the images to 60 frames. Component output is converted to 60 frames during playback as well. 24p DV format video uses a 2:3:2:3 pulldown (24p Mode). A 2:3:3:2 pulldown (24p Advanced Mode) is also supported. It can shoot with the same number of frames as movie film.
- Tapes recorded in the DVCAM format can only be played back (simple playback). Recording in the DVCAM format is not possible. DVCAM is a registered trademark of Sony Corporation.
- 60 Hz/50 Hz HD or HDTV signals
Supports both 60 Hz/50 Hz HD or HDTV signals. You can select this in a menu screen.
- Cross-convert video output
You can output converted video from the video output connectors. You can select this in a menu screen.
- Outputs composite, component, Y/C separate and RGB signals as analog video in DV format. Outputs composite and component signals in HDV format.
- Features HD/SD SDI output terminals
Outputs serial digital HD and SD signals.
- Focus assist function
Enables easy and accurate focusing during shooting.
- User buttons added
Enables you to switch camera settings instantly to suit the shooting conditions.
- External video signal input enabled
Records composite video signals from an external source.
- GENLOCK input terminal
Input BB (Black Burst) or HD Tri-sync signals. SC phase and HD/SD H phase adjustments can be performed.
- Time code reader/generator
The built-in time code reader/generator can be used to record the time code and user's bits.
 - Time code input/output terminal and slave lock function
Slave lock to an external time code generator connected to the time code input terminal.
The time code output terminal outputs built-in time code generator data.
 - Built-in large 3.5" color LCD display
In addition to displaying the camera image and the playback image, the LCD monitor shows the status screens, menu screens for settings, and alarm indications.
 - Built-in monitor speaker for audio checking
The input audio can be monitored in recording or EE mode. The playback sound can be monitored in the playback mode. The speaker also outputs an alarm tone in case an abnormal condition occurs in this device.
 - Recording check function for convenient recording review function
 - Camera section designed with 3-CCD system for high-quality picture
1/3" 3-CCD with 1,110,000 effective pixels employed. Digital signal processing for reproduction of HDV/DV high-quality picture.
 - Multi-Zone Auto Iris Detection Circuit
Multi-zone auto iris detection circuit ensures optimum iris position even in back light conditions or when a bright subject moves in a frame.
 - Safety Zone indication in viewfinder
 - Zebra pattern video level indication in viewfinder
 - Full Auto Shooting (FAS) function
Eliminates the need for troublesome switch or filter operations by automatically providing a wide range of compatibility with shooting conditions that change as you move between indoors and outdoors or between bright and dark locations.
 - ND filters for 1/4ND, 1/16ND provided
 - IEEE1394 connector
IEEE1394 connector (6-pin) provided. Enables transfer of digital data to other equipment provided with IEEE1394 connector, such as a non-linear editing system. (Power cannot be supplied.)
 - 1/3" bayonet type lens
 - Built-in color bars (ARIB (multi-format color bars), SMPTE/EBU type)
 - Shutter speeds and menus can be selected using a dial, making it very easy to use.
 - Variable scan shutter
There is no flicker when shooting computer screens and other non-NTSC/PAL format screens.
 - Slow shutter
Makes it possible to brightly shoot video of dark subjects with little motion by accumulating the images.
 - Backup recording function
Continuous extended recording is possible by connecting to HDV/DV devices.
 - Connect to KA-HD250 Studio Kit and use as a studio camera.

CONTENTS

ACCESSORIES	2
MAIN FEATURES	3

INTRODUCTION

Precautions for Proper Use	6
Routine and Periodical Maintenance	7
Precautions for Use of Head Cleaning Tape	7
Battery Pack to be Used	8
Videocassette to be Used	8
For recording and storing videotapes in the best condition	8
Condensation	9
Characteristic CCD Phenomena	9

CONTROLS, INDICATORS AND CONNECTORS

ZOOM Lens	10
Front Section	11
Rear Section	12
LCD Door	13
Right Side Section	14
Left Side Section	16
Top Section	18
Recording and Image Output Formats	20
Indications on the LCD Monitor and in the Viewfinder	22
Status Screens	22
Status Screens in the Camera Mode	23
Status Screen in VTR MODE	28
Magnified Status Indications on the LCD Monitor	29
Auto White Balance Indication (Camera mode only)	30
Menu Setting Screen	30
Alarm Message Display	30
Safety Zone Indication (Camera mode only)	30
Switching between the LCD Screen and Viewfinder Display	31

PREPARATIONS

Basic System	32
Attaching the Zoom Lens	33
Attaching the Microphone (Provided)	33
How to Attach the Viewfinder	33
Inserting an SD Memory Card	34
Inserting an SD Memory Card	34
Taking out the SD memory card	34
About SD Memory Cards	34
Attaching the Tripod Base (Provided only for U model)	35
AC Operation	36

Charging the Built-in Battery	36
Battery Operation	37
Attaching the Battery	37
Removing the Battery	37
Precautions for the Battery Operation	38
Remaining Battery Power Display	38
Operating Time with Battery Pack	38
Precautions for the Battery Pack	38
Recharging	38

PREPARATIONS FOR OPERATION

Turning the Power ON	39
Turning the Power ON	39
Turning the Power OFF	39
Loading/Unloading the Cassette	40
Cassette Loading	40
Unloading the Cassette	40
Setting and Displaying the Date and Time	41
Setting the Date and Time Style	41
Setting the Date and Time	42
Displaying the Time and Date on the Screen	42
Displaying Time Code	43
Displayed Time Code/User's Bit	43
Time code input entered the IEEE1394 connector	43
Presetting and Recording of Time Code	44
Setting	44
Presetting time code data	45
Presetting user's bit data	45
Zero-resetting the Time Code or User's Bit Data	45
Presetting the Time Code from the LCD Screen	46
Recording Time Codes in Continuation of Time Codes Recorded on Tape	47
Playing Back Time Code	47
Synchronizing with the Time Code of the IEEE1394 (DV)-Connected Master Unit	48
Synchronizing with an External Time Code Generator	49
Screen Adjustment	50
Viewfinder Adjustment	50
Back Focus Adjustment	51
White Balance Adjustment	52
White Balance Adjustment	52
Full Auto White Balance (FAW)	52
White Shading Adjustment	53

SETTING AND ADJUSTMENTS BEFORE SHOOTING

Setting the Video Format	54
Setting the FRAME RATE Item	54
Camera Settings	55
Screen Size (4:3/16:9) Mode Selection	55
Audio Input Signal Selection	56
Selecting the CH-2 channel input connector	56
Selecting the audio signal input	56

Adjusting Audio during Recording	56
Monitoring Audio during Recording	57

SHOOTING OPERATION

Basic Recording Operation	58
If the Record-Standby Mode Continues	59
Checking Recorded Contents in Record-Standby Mode (Recording Check Function)	59
HEADER REC Function	60

PLAYBACK MODE

Playback Procedure	62
Fast-Forward, Rewind	62
Search	62
Outputting Audio	63

USING EXTERNAL COMPONENTS

Connecting the Video Signal Cables	64
Connecting the IEEE1394 Cable	64
Recording Composite Video Signals from an External Device	65
Using GENLOCK Functions	66
Dubbing with AV Devices	67
HDV/DV Dubbing	68
Backup Recording	70
Connect a Remote Control Unit (RM-LP55/RM-LP57)	71

MENU SCREENS

Menu Screen Configuration	73
Setting Menu Screens	75
TOP MENU Screen	76
VIDEO FORMAT[1/2] Menu Screen	77
VIDEO FORMAT[2/2] Menu Screen	79
CAMERA OPERATION Menu Screen	80
CAMERA PROCESS[1/2] Menu Screen	81
CAMERA PROCESS[2/2] Menu Screen	82
ADVANCED PROCESS Menu Screen	83
COLOR MATRIX ADJUST Menu Screen	84
SKIN COLOR ADJUST Menu Screen	84
WHITE BALANCE Menu Screen	85
SWITCH MODE Menu Screen	86
AUDIO/MIC[1/2] Menu Screen	87
AUDIO/MIC[2/2] Menu Screen	88
LCD/VF[1/4] Menu Screen	89
LCD/VF[2/4] Menu Screen	90
LCD/VF[3/4] Menu Screen	91
LCD/VF[4/4] Menu Screen	92
TC/UB/CLOCK Menu Screen	93
HEADER REC Menu Screen	94
TIME/DATE Menu Screen	95

OTHERS[1/2] Menu Screen	96
OTHERS[2/2] Menu Screen	97
GENLOCK Menu Screen	99
FILE MANAGE Menu Screen	100
Displaying the FILE MANAGE menu screen	100
Loading a menu settings file	100
Saving settings	101
Resetting the menu settings to the factory settings	102
Initializing (formatting) an SD memory card	102

FEATURES OF THE CAMERA SECTION

How to Use Skin Detail	103
Outputting Color Bars	105

OTHERS

Warnings and Responses	106
Troubleshooting	110
How to Display the Hour Meter	111
Specifications	112
EXTERNAL DIMENSIONS	113

Precautions for Proper Use

- **Supply voltage**
Make sure that the power is between 11 V and 15 V DC. If the power voltage is too low, abnormal color and increased noise may occur.
- **Allowable ambient temperature and humidity**
Be sure to use this device within the allowable temperature range of 0°C to 40°C and a relative humidity of 30% to 80%. Using this device at a temperature or humidity outside the allowable ranges could result not only in malfunction but the impact on the CCD elements could be serious as small white spots may be generated.
- **Strong electromagnetic waves or magnetism**
Noise may appear in the picture or audio and/or the colors may be incorrect if the camera is used near a radio or television transmitting antenna, in places where strong magnetic fields are generated by transformers, motors, etc., or near devices emitting radio waves, such as transceivers or cellular phones.
- **Use of wireless microphone near the camera**
When a wireless microphone or wireless microphone tuner is used near the camera during recording, the tuner could pick up noise.
- **Avoid using or placing this device in places;**
 - subject to extreme heat or cold;
 - with excessive dirt or dust;
 - with high humidity or moisture;
 - subject to smoke or vapour such as near a cooking stove;
 - subject to strong vibrations or on an unstable surface;
 - also do not leave this device for long hours in a parked car under direct sunlight or near room heating equipment.
- **Do not leave this device where it is subject to radiation or X-rays or where corrosive gasses occur.**
- **Protect this device from being splashed with water (especially when shooting in the rain).**
- **Protect this device from being wet when shooting on a beach.**
In addition, salt and sand may adhere to the camera body. Be sure to clean the camera after use.
- **Protect this device against penetration of dust when using it in a place subject to sandy dust.**
- **Optical performance of lens**
Due to the optical performance of the lens, color divergence phenomena (magnification chromatic aberration) may occur at the periphery of the image.
This is not a camera malfunction.
- **Noise may appear in the viewfinder when switching between the playback picture and the EE picture.**
- **Use this device in an upright position.**
If placed on its side, heat release efficiency will deteriorate, adversely affecting the tape transport. Depending on circumstances the tape may also be damaged.
- **Vibrations**
Colors may fail to appear and/or the image and sound may be disturbed during VTR playback in locations subjected to strong vibrations.
- **Precautions for transportation**
Do not drop or hit this device against a hard object.
- **Remove the videocassette before transporting this device.**

- **Do not insert an object other than a videocassette in the cassette insertion slot.** Be sure to close the cassette cover when this device is not to be used for a long period.
- **Do not set the POWER switch to OFF or remove the power cable during recording or playback.** Otherwise the tape may be damaged.
- **The sensitivity level of the provided microphone is set lower than the reference input (-60 dBs) setting.**
- **When this device is not in use, be sure to set the POWER switch to OFF in order to reduce power consumption.**
- **Cleaning the body:** Wipe body with a dry, soft cloth. To prevent deformation of the body, etc. and to avoid operation hazards, do not allow volatile liquids such as benzine and thinner to touch the body, and do not wipe it with a cloth soaked in such a liquid. When it is extremely dirty, soak the cloth in a solution of neutral detergent, wipe the body with it, and then use a clean cloth to remove the detergent.
- **The camera may not show stable pictures in the period immediately after the power is turned on, but this is not a malfunction.**
- **A sound occurs when the built-in head cleaner that runs when you load or eject a videocassette operates, but this is not a malfunction.**
- **The LCD monitor and the viewfinder screen**
The LCD monitor and the viewfinder screen are manufactured using high-precision technology. Black spots may appear on the LCD monitor and the viewfinder screen, or red, blue, green and/or white spots may not turn off. However, this is not a malfunction and these spots are not recorded on the tape.
- **If you use this device continuously for a long period of time, the characters displayed in the viewfinder may temporarily remain on the screen. This is not recorded on the tape. In addition, they are no longer displayed if you turn the power off and then on again.**
- **If you use this device in a cold location, the images may appear to lag on the screen, but this is not a malfunction. This is not recorded on the tape.**
- **Do not insert fingers or foreign objects into the cassette insertion slot as this may result in personal injury or damage to the mechanism.**
- **To prevent damage to the connectors, use this device with the connector covers on when you are not using the video/audio signal output connectors.**

CAUTION

- **Do not point the lens or viewfinder directly at the sun or other strong light source.**
 - Eye damage could result.
 - If the lens or viewfinder is left pointed at the sun, rays may collect inside this device and cause damage or a fire.
- **When carrying the camera, be sure to hold the carrying handle. Holding the lens or viewfinder may result in damage.**

Routine and Periodical Maintenance

The GY-HD250/GY-HD251 incorporates precision mechanical parts, which will collect dirt, wear out and deteriorate as this device is used. After this device has been used for a long period even in a normal environment, the heads, drums and tape transport mechanisms also collect dirt. Especially, dust which penetrates the inside of the VTR section during outdoor use will promote the wear and deterioration of mechanical parts by causing poor contact between tape and heads or failing to maintain the video and audio quality at high levels. To prevent wear and deterioration, clean the mechanical parts using a head cleaning tape as routine maintenance. However, cleaning with a head cleaning tape alone is not enough for cleaning the entire tape transport mechanism, so it is also recommended to apply periodical maintenance (inspection) to prevent the sudden occurrence of failure. As the replacement, adjustment and servicing of parts require advanced skill and equipment, please consult the person in charge of professional video equipment at your nearest JVC-authorized service agent.

Head Cleaning

- To maintain beautiful pictures and sound, be sure to use a head cleaning tape to clean the head periodically. See "Precautions for Use of Head Cleaning Tape". If head cleaning is not performed periodically, a type of mosaic noise called block noise may appear in the picture or sound may be interrupted.



Block Noise

- Please use cleaning tape produced by JVC. Do not use head cleaning tapes other than specified. See "Precautions for Use of Head Cleaning Tape" about how to use the head cleaning tape and precautions for use of the head cleaning tape.
- When dust adheres to the heads, the warning message "HEAD CLEANING REQUIRED!" is displayed on the LCD monitor, and in the viewfinder during playback and recording check using the RET button on the lens section.

Periodical Maintenance

Contents : Check or replace the following mechanical parts according to the running time.

Usage Time	500H	1000H	1500H	2000H
Drum assembly (including heads)	○	☆	☆	●
Tape guides, rollers	○	☆	☆	●
Belt gears	—	☆	☆	●
Drive parts	—	—	☆	●

- : Clean, check and adjust.
- ☆ : Clean and check. Replace as required.
- : Replace.

- The maintenance contents vary depending on the operating environment and method. Therefore, the data in the chart should be considered as a reference.

Time management

The accumulated running time of this device can be confirmed with the hour meter display (which shows the accumulated drum and fan motor running time). See "How to Display the Hour Meter" on page 111.

For consultations related to the maintenance planning or cost, please contact the person in charge of professional video equipment at your nearest JVC-authorized service agent.

Precautions for Use of Head Cleaning Tape

Please use cleaning tape produced by JVC.

Adhere to the following precautions when using the head cleaning tape.

- Insert the cleaning tape. Press the PLAY/STILL button after the cleaning tape is fully loaded. The tape runs for 10 seconds at a time in the PLAY mode. (The tape stops automatically and then this device enters the STOP mode.)
 - Do not use the tape more than four times at the most for each cleaning.
- Use the following chart as a guide for periodical head cleaning.

Running	Low temperature	Room temperature	High temperature
Operating environment	0°C to 10°C	10°C to 35°C	35°C to 40°C
Yardstick for use of cleaning tape	1 to 2 times every 5 hours	1 to 2 times every 20 to 30 hours	1 to 2 times every 5 hours

- Note 1) When used in a low humidity environment, head cleaning should be conducted at intervals half of those given in the chart above.
- Note 2) If an M-DV80 tape is used immediately after head cleaning, the "HEAD CLEANING REQUIRED!" indicator may remain on. In this case, let the tape run as the indicator will turn off after the tape has run for a while.
- Note 3) Use the cleaning tape in the room temperature (10°C to 35°C).
- Note 4) The cleaning tape case contains instructions for use of the cleaning tape. However, some of these instructions differ from the contents of this sheet. When using the cleaning tape, please follow the instructions of this sheet.
- Note 5) If the "HEAD CLEANING REQUIRED!" does not disappear after repeated head cleanings, the recording tape may be abnormal. Avoid excessive repeated use of the head cleaning tape.

Battery Pack to be Used

The GY-HD250/GY-HD251 can use any of the following batteries. (Factory setting)

- U model: Anton Bauer battery
- E model: IDX battery

Recommended batteries

- U model: Dionic 90 (Anton Bauer)
- E model: Endura-7 (IDX)

CAUTION

Use only the recommended batteries.
If a heavy battery is used, the battery may fall out depending on the way the HD camera recorder is used.

Videocassette to be Used

- Use JVC's videocassette tapes marked with the **Mini DV** symbol.
- Mini DV videocassette : M-DV63HD
M-DV63PROHD
- * Do not use M-DV80.
- Videocassettes cannot be used upside down.
- Avoid storing a videocassette with its tape not being completely wound, as this may damage the tape. Rewind it to the beginning before placing a cassette into storage.
- Store videocassettes in a place with little humidity and good ventilation where mould does not form.
- After a videocassette tape has been used repeatedly, it becomes unable to maintain full performance due to an increase in noise caused by dropouts, etc. Do not continue to use a dirty or damaged tape, as this will reduce the rotary head life.
- Videocassette tapes with the **Mini DV** symbol are provided with a switch on the back to prevent accidental erasure.
- Slide the switch to SAVE to protect the required recording in the tape from being overwritten.
- To record on the tape, slide the switch to REC.

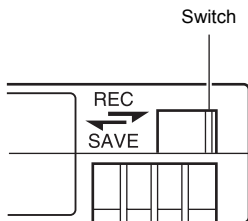

For recording and storing videotapes in the best condition

Observe the following instructions for the best recording and storage of videotapes.

- Take care of the conditions of handling videotapes. It is recommended that you record and store videotapes in the environment below.

	Recording	Storage	
		Short period (Up to 10 years)	Long period (Over 10 years)
Temperature	17°C to 25°C	15°C to 23°C	15°C to 19°C
Humidity	30% to 70%	40% to 55%	25% to 35%
Hourly temperature change	Less than 10°C	—	—
Hourly humidity change	Less than 10%	—	—

- Do not leave the videotapes neglected for a long period. If videotapes are left wound for a long period of time, it may result in distortion of the tape. Also it may cause tape-to-tape adhesion (known as blocking). It is recommended that videotapes be unspooled and rewound once a year for refreshing.
- When tapes are not in use, store them in cases and on end. Storage cases protect videotapes from humidity, dust and ultraviolet light. Keep tapes in cases and do not store them lying flat. When housed in a horizontal position, pressure from other tapes can cause distortions and deformations of the tape edges.

Condensation

- If this device has been cooled down in a cold place and is then carried to a warm place, the moisture contained in the warm air may adhere to the head drum or tape guides and be cooled into water droplets. This phenomenon is referred to as condensation (dew). When this occurs, the head drum and tape guides are covered with droplets allowing the tape to be stuck to them, leading to tape damage.
- Condensation occurs in the following cases:
 - When this device is suddenly moved from a cold place to a warm place.
 - When a room heater has just started or when this device is exposed directly to cold air from an air conditioner.
 - When this device is placed in a very humid place.

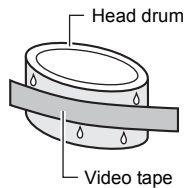

Do not leave the videocassette inserted when moving the camera under conditions where the temperature environment changes. After moving this device, do not use until the internal parts have stabilized.

- "CONDENSATION ON DRUM" is displayed on the LCD monitor and in the viewfinder when condensation occurs in this device.

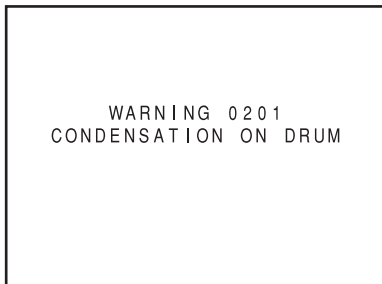

Keep the power on until the warning message disappears. If the power is turned off while the warning message is displayed, condensation may remain in the device even if the warning message is not displayed. Wait until this device is completely dry before using.

- Pay attention to condensation even before the condensation indication appears. As condensation forms gradually, the condensation indication may not appear for the first 10-15 minutes after condensation has formed inside. In an extremely cold place, the condensation could freeze and turn into frost. In such a case, it takes an additional 2-3 hours for the frost to first melt into condensation and then to be dissolved.
- To prevent condensation
 - When moving this device from one place to another where the temperatures are greatly different, first remove the vid-

ecassette, place this device in a tightly sealed vinyl bag, and then move it to a new environment.

To ensure no condensation occurs, allow the temperature of this device in the bag to reach that of the new environment before using it.

Characteristic CCD Phenomena

Smear and Blooming

Due to the physical structure of a CCD it is possible to induce vertical streaking (called "smear") when shooting an extremely bright light source. Another effect is the expansion of light around a bright light or object (called "blooming"). The CCD employed in this device is characterized by inducing very little smear or blooming. Nevertheless, please take note that smear or blooming may be induced when shooting a bright light source.

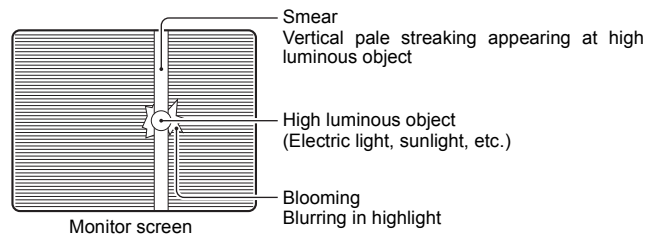

Moire or Aliasing

Shooting stripes or fine patterns may cause a jagged effect or a banding in fine mesh patterns.

White dots

High temperatures can cause CCD sensor pixels to produce the effect of white dots in the image. This condition is conspicuous especially when gain is applied. This is a characteristic of the charged-coupled device (CCD). As far as possible, use this device under conditions where the temperature of this device does not increase.

ZOOM Lens

The zoom lens is not provided with the GY-HD250CHU or the GY-HD251CHE.

Th16 × 5.5BRMU

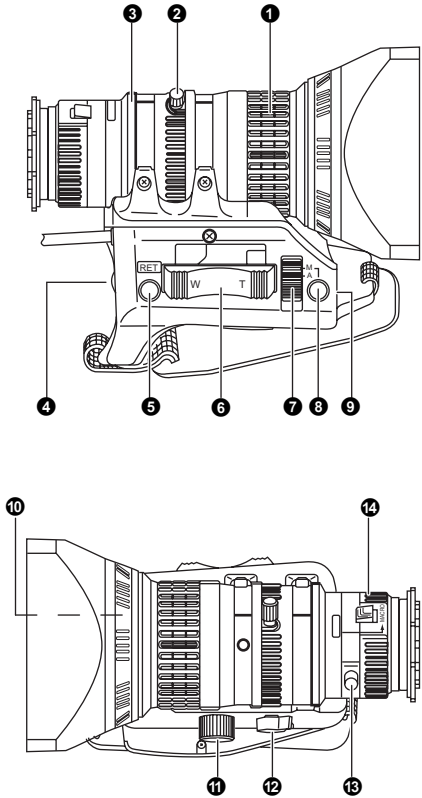

- ① FOCUS ring**
Manual focus ring.
- ② ZOOM lever/ring**
This is the manual zoom ring equipped with a zoom lever. To adjust the zoom manually, turn the zoom mode knob ⑫ to position “M”.
- ③ IRIS ring**
Manual iris ring. To activate the auto iris feature, set the Iris Mode switch ⑦ to “A”.
- ④ [VTR] VTR trigger button**
To start/stop shooting.
- ⑤ [RET] Return video button**
You can only monitor the return video signal from the VTR on the viewfinder, LCD monitor and video signal connector while this button is pressed. When the camera control unit is connected, you can monitor the return video signal on the viewfinder while this button is pressed. You cannot monitor on the LCD monitor or video output terminal. When you set the LENS RET item to “FOCUS ASSIST” in the SWITCH MODE menu screen, you can use this button as the FOCUS ASSIST button.
☞ See page 86.

- ⑥ ZOOM servo control lever**
To operate the servo zoom feature with this lever, set the ZOOM knob ⑫ to “S”.
 - Pressing the “W” section of this lever increases the angle of the lens for a wider shooting angle.
 - Pressing the “T” section of this lever narrows the lens angle perspective for telephoto shots.
 - Pushing harder changes the speed of the zoom.
- ⑦ IRIS mode switch**
A : Activates the auto iris feature.
M : Allows manual iris control.
- ⑧ Momentary auto iris button**
When the IRIS mode switch ⑦ is at “M”, pushing this button activates the Auto Iris Function while it is held down only.
- ⑨ [S] IRIS speed adjusting control**
For adjusting the iris operation speed.

MEMO

If the speed becomes too fast, hunting may occur. To avoid the phenomena described above, perform adjustment again.

- ⑩ FILTER thread**
Protect the lens with a clear filter or UV filter by screwing the filter onto the thread inside the lens hood from the front. Other filters can be used for various effects.
- ⑪ ZOOM servo connector**
Connect an optional zoom servo unit here.
- ⑫ [ZOOM] ZOOM mode knob**
S : Servo zoom mode. Allows operation by the zoom servo control lever ⑥.
M : Manual zoom mode. Allows zoom control by the zoom lever/ring ②.
- ⑬ BACK FOCUS ring/fixing screw**
For back focus adjustment only. Secure with the screw knob after adjustment. ☞ See “Back Focus Adjustment” on page 51.
- ⑭ Macro focusing ring (for close-up shooting)**
By rotating this ring in the direction of the arrow, close-up shooting of very small objects becomes possible. Normal focus adjustment and zooming are not available in the macro mode. To shoot images in the macro mode, set the focus ring ① to the infinite position (∞) and the zoom ring ② to the maximum wide-angle position. To adjust the focus of the macro image, rotate this ring in the direction of the arrow until the object is focused.

CAUTION

- The back-focus knob is located close to the macro ring, be careful not to mistake the back-focus knob for the macro ring.
- After the required operation, be sure to return the macro focusing ring to the normal position.

☞ See “Attaching the Zoom Lens” on page 33.
☞ See “Back Focus Adjustment” on page 51.

Front Section

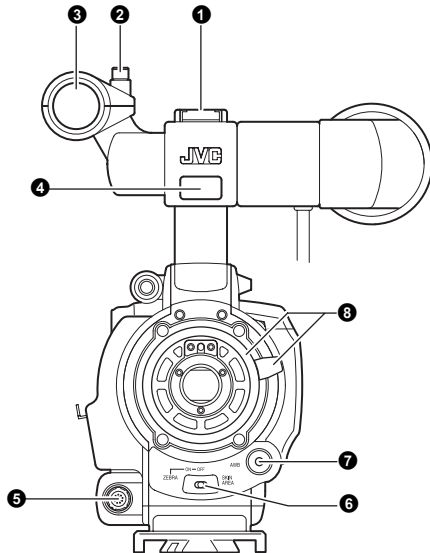

1 Shoe

Makes it possible to mount separately sold lights and accessories.

2 Knob

This is the mounting knob for the microphone holder 3.

3 Microphone holder

Makes it possible to attach the provided microphone or a separately sold microphone.

☞ See “Attaching the Microphone (Provided)” on page 33.

4 Front tally lamp

This lamp lights up when the GY-HD250/GY-HD251 enters the record mode. It blinks during the transition to the record mode.

When the tape has run out, or the VTR enters the warning mode, it blinks quickly.

- Use the FRONT TALLY item on the OTHERS[1/2] menu screen to select whether or not the lamp should light and the lighting pattern.

☞ See page 96.

5 [LENS] Lens control connector

Connect 12-pin lens control cable from lens here.

Pin No.	Function	Pin No.	Function
1	Return switch	7	Iris position
2	VTR trigger	8	IRIS A/R INPUT
3	GND	9	EXTENDER position
4	Lens AUTO/MANU control	10	ZOOM position
5	IRIS control	11	—
6	+12V DC	12	—

6 [ZEBRA] Zebra switch

When this switch is ON, a zebra pattern is imposed on the viewfinder or LCD areas having luminance levels in accordance with the menu settings made for the video signal. This pattern can be used as a reference for manual adjustment of the lens iris. Zebra patterns are also displayed during color bar display when this switch is set to ON.

- The default value is 70% - 80%. The luminance level can be changed with the ZEBRA setting in the LCD/VF[1/4] menu screen.

☞ See page 89.

While this switch is pressed to the SKIN AREA side, the color tone areas specified with the SKIN COLOR ADJUST item on the ADVANCED PROCESS menu are indicated in the viewfinder. The switch returns to the OFF position when released.

☞ See “How to Use Skin Detail” on pages 103 and 104.

- * The Skin Detail color tone areas are not indicated while the color bar or VTR playback picture is shown in the viewfinder or on the LCD monitor.

7 [AWB] Auto white balance button

When the WHT.BAL switch 16 on page 15 is set to A or B and you press this button, the white balance is automatically adjusted.

- * It is not activated in preset, full auto shooting, full auto white balance and color bar modes.

☞ See “White Balance Adjustment” on page 52.

8 Lens mounting ring/Lens lock lever

Hold the lens and use the lever to turn the ring anticlockwise to release lens.

To mount lens make sure the lens guide pin fits well, and then turn the ring clockwise until firm.

☞ See “Attaching the Zoom Lens” on page 33.

Rear Section

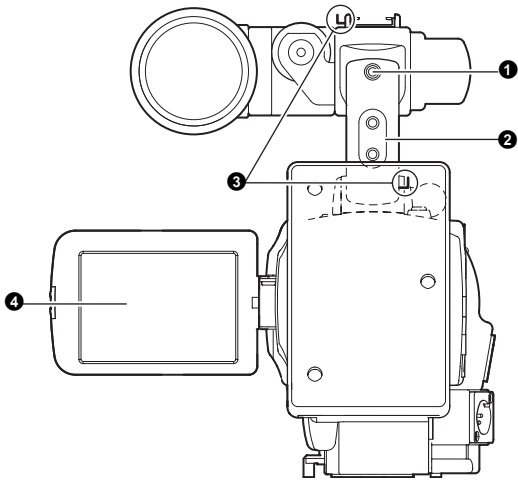

1 Back tally lamp

This lamp lights up when the GY-HD250/GY-HD251 enters the record mode. It blinks during the transition to the record mode.

When the tape has run out, or the VTR enters the warning mode, it blinks quickly.

- Use the BACK TALLY item on the OTHERS[1/2] menu screen to select whether or not the lamp should light and the lighting pattern.

☞ See page 96.

2 [PHONES] Earphone jack

This is a stereo mini-jack for connecting an earphone for audio monitoring. Plug in an earphone or headphone with a 3.5 mm diameter plug. The earphone can also be used to monitor alarm tones in accordance with the circumstances.

The audio channel to be output is selected with the AUDIO MONITOR item on the AUDIO/MIC[2/2] menu screen and MONITOR SELECT switch 14 on page 19.

The audio output level is adjusted with the Audio monitor volume control 3 on page 14.

MEMO

- The volume of the alarm sound is set with the ALARM VR LEVEL item on the OTHERS[1/2] menu screen.
- When using a stereotyped jack and stereo sound should be output, the following setting should be performed.
Set the MONITOR SELECT switch 14 on page 19 to BOTH.
Set the AUDIO MONITOR item on the AUDIO/MIC[2/2] menu screen to STEREO.

■ Connecting the Earphone Cable

To reduce the emission of unwanted radio waves, be sure to attach the provided clamp filter as shown in the figure below.

- Attach the clamp filter as close to this device as possible, as shown in the figure.

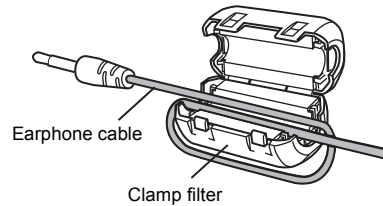

3 Shoulder belt hooks

Allows you to attach a separately sold shoulder belt.

4 LCD monitor

Shows a color camera image or the VTR playback picture. It is also used for displaying the following:

- Menu Setting screens
- Characters showing the whether the GY-HD250/GY-HD251 is set to shooting mode or VTR playback mode
- Date and time and time code
- Audio level meter
- Warning indications, etc.

☞ See page 22.

LCD Door

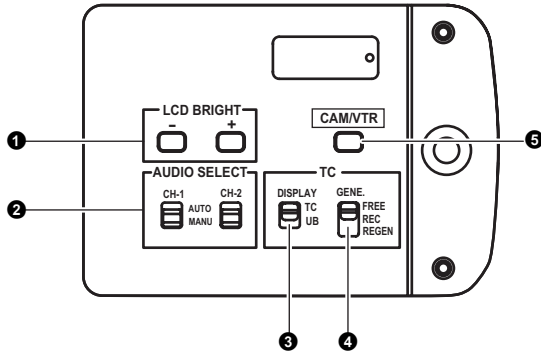

① [LCD BRIGHT +/-] LCD brightness +/- button

This button is for adjusting the brightness of the LCD monitor display.

- Pushing the button in the + direction makes the monitor brighter.
- Pushing the button in the – direction makes the monitor darker.
- Pushing the +/- buttons simultaneously returns the setting to the standard setting.

② [CH-1/CH-2 AUDIO SELECT] CH-1/CH-2 audio selector switch

Selects the method of adjusting the CH-1 and CH-2 audio channel audio levels.

AUTO : The audio level is automatically adjusted according to the input level. When excessive audio is input, the limiter works to suppress the audio level.

The “AUTO” LED in the CH-1/CH-2 AUDIO LEVEL area 16 on page 15 lights.

MANU : Allows you to adjust the audio levels using the CH-1/CH-2 AUDIO LEVEL volume controls 16 on page 15.

Set AUDIO LIMITER on the AUDIO/MIC[1/2] menu screen to use limiter functions when excessive audio is input.

See “AUDIO LIMITER” on page 87.

③ [TC DISPLAY] TC/UB display switch

Selects the contents displayed on the TC counter of the LCD monitor or in the viewfinder. (This switch works when the TC/UB item on the LCD/VF[3/4] menu screen is set to ON.)

TC : Set to this position to display time code values.

UB : Set to this position to display the user’s bits values.

④ [TC GENE.] Time code generator setting switch

Switch for setting the time code generator to preset mode or regeneration mode. It is also used to select the time code run mode when the preset mode is selected.

FREE : The preset mode is selected, and the time code run mode becomes the FREE run mode.

Set to this position to record with the time code or user’s bits set anew (preset). In this setting, the time code always operates in the run mode.

* If this setting is used when recording scenes one after another, the time codes become discontinuous at the transition points between scenes.

REC : The preset mode is selected, and the time code run mode becomes the REC run mode.

Set to this position to record with the time code or user’s bits set anew (preset). The time code operates in the run mode during recording only. If this setting is used when recording scenes one after another, the time codes are recorded as continuous time codes.

REGEN : Regeneration mode, in which this device reads existing time codes on the tape and records time codes in continuation of the existing ones. Set to this position when you want to add additional time codes to time codes already recorded on the tape.

MEMO

- This switch is enabled when TCG SOURCE on the TC/UB/CLOCK menu screen is set to INTERNAL.
- Preset of time code and user’s bits is performed on the TC/UB/CLOCK menu.
 - See page 44.
 - See “TC/UB/CLOCK Menu Screen” on page 93.

⑤ [CAM/VTR] Camera/VTR mode switch button

Each time you press this button, the mode switches between camera mode and VTR mode.

When you do this, the VTR indicator 16 on page 19 displays the following statuses.

While the mode is being switched : Flashing

In VTR mode : Lit

In camera mode : Off

- Select the Camera mode to record the camera image.
- Select the VTR mode to playback VTR or to input the HDV/DV signal from the IEEE1394 connector 10 on page 16.
- When the power is turned on, the mode becomes the Camera mode.

Right Side Section

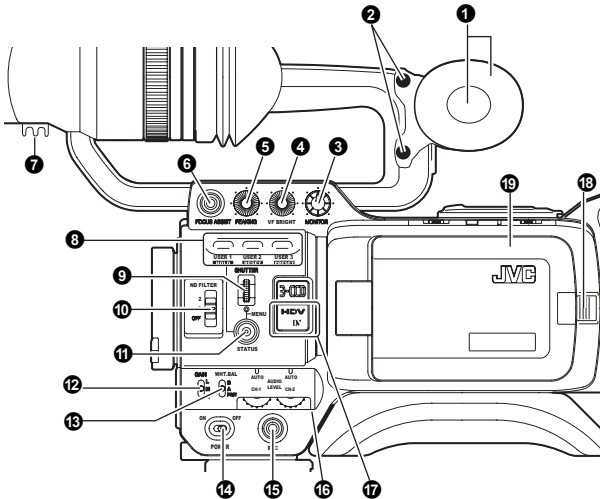

1 Monitoring speaker (Cheek pad)

- In the Camera mode, the input sound can be EE monitored. In the VTR mode, the speaker outputs the VTR playback sound. In the VTR mode, the HDV/DV input sound can be EE monitored. The sound to be output is selected with the MONITOR SELECT switch 14 on page 19.
- The sound level is adjusted with the MONITOR sound level volume 3. This speaker also outputs various warning sounds superimposed on other sound. See "Alarm Sound" on page 109.

2 Cheek pad set screw

Screw for adjusting the height of the cheek pad.

3 [MONITOR] Audio monitor volume control

Adjusts the volume of the monitoring loudspeaker and ear-phone.

4 [VF BRIGHT] Viewfinder brightness adjustment

To adjust the brightness of the viewfinder.

See page 50.

5 [PEAKING] Contour adjustment

To adjust the contours of the LCD monitor and viewfinder image.

* When the Focus Assist function is running, this control does not operate.

See page 50.

6 [FOCUS ASSIST] Focus assist button

When you press this button during shooting, the area of focus is displayed in blue, red or green, making it easy to focus accurately.

MEMO

- When FOCUS ASSIST on the LCD/VF[1/4] menu screen is set to ACCU-FOCUS and this button is pressed, ACCU FOCUS functions with FOCUS ASSIST. This makes depth of field shallower, making it easier to focus.
- This button has the same function as the FOCUS ASSIST button 7 in the Top Section.

See "LCD/VF[1/4] Menu Screen" on page 89.

7 Clamp

Attach the cable from the viewfinder here.

8 [USER1/2/3] User buttons

You can assign camera functions to the USER1 - 3 buttons.

Use them to switch shooting conditions depending upon the subject.

Set them using the USER1 - 3 items in the SWITCH MODE menu screen.

See page 86.

Use this button to preset the time code.

See page 46.

MEMO

- The USER buttons work together with the menu settings.
- When a menu screen is being displayed, they also function as menu operation buttons. See "Setting Menu Screens" on page 75.

9 [SHUTTER] Shutter/Menu dial

- Every time this dial is pressed while in the normal screen mode (when the menu screen is not displayed), the shutter speed switches between on/off.

- When this dial is turned 1 click up or down in the normal screen mode, the shutter speed indicator is shown for about 3 seconds on the LCD monitor or in the viewfinder. The shutter speed is changed when this dial is turned while the shutter speed indicator is shown. See page 86.

- When this dial turned upward or downward while the menu screen is displayed, the cursor (▶) also moves upward or downward to allow selection of items in the menu. To change the setting value of the item, press this dial. When the setting value starts blinking, turn this dial upward or downward to change the setting. See "Setting Menu Screens" on page 75.

10 [ND FILTER] ND filter switch

Switches the built-in ND filter.

OFF : Turns the filter OFF (FILTER OFF)

1 : Cuts the light intensity to approximately 1/4. (1/4ND)

2 : Cuts the light intensity to approximately 1/16. (1/16ND)

When you change this switch, the type of the new ND filter is displayed in the LCD monitor or viewfinder.

CAUTION

If you switch the ND filter while shooting is in progress, the picture may be disturbed or noise may occur in the audio.

See "Camera Settings" on page 55.

11 [STATUS] Status/Menu button

- Pressing this button in the normal screen mode (condition in which the menu screen is not shown) displays a status screen in the viewfinder or on the LCD monitor. The displayed status screen changes each time the button is pressed.
 - See "Status Screens" on page 22.
- Pressing this button for more than 1 second in the normal screen mode displays the menu screen in the viewfinder or on the LCD monitor. Pressing this button while the menu screen is displayed in the viewfinder or on the LCD monitor makes the menu screen disappear.
 - See "Setting Menu Screens" on page 75.

12 [GAIN] Sensitivity selector switch

Electronically boosts the light sensitivity when there is insufficient illumination on the subject. The boosting level differs depending on the switch position as follows:

(Factory presets)

L : 0 dB (no boosting is applied)

M : 9 dB (boosted to approximately 3 times the original)

H : 18 dB (boosted to approximately 8 times the original)

- The boosting level for each switch position can be changed with the SWITCH MODE menu screen.
 - See page 86.
- The more the boosting level is increased, the more the resulting image will be noisy.
- When the FULL AUTO switch 17 on page 19 is "ON", this is fixed at "ALC".

13 [WHT.BAL] White balance switch

Three white balance modes are selectable with this switch.

- B** : Switch into white balance mode memorized in B. If white balance is performed with the switch in this position, it will be memorized into B.
- A** : Switch into white balance mode memorized in A. If white balance is performed with the switch in this position, it will be memorized into A.
- PRST** : Switch into white balance mode (3200K or (PRESET) 5600K) set in PRESET TEMP. item on the CAMERA OPERATION menu screen.
 - See page 80.

FAW (Full Auto White Balance) mode can be set to A, B or PRESET with the SWITCH MODE menu screen.

See page 86.

In the FAW mode, video color temperatures are constantly sampled for automatic adjustment to a proper white balance.

- When the FULL AUTO switch 17 on page 19 is "ON", this is fixed at "FAW".

MEMO

Fine-tune red and blue to match the white adjusted in auto white balance in WHITE PAINT<R>/ on the WHITE BALANCE menu screen. (Available only when this switch is set to A or B.)

See "WHITE BALANCE Menu Screen" on page 85.

14 [POWER] Power ON/OFF switch

Switch that turns the power ON/OFF.

When the power is OFF, "POFF" is displayed in the LCD monitor or viewfinder.

- Wait at least 5 seconds if you need to turn the power on again.

15 [REC] REC trigger button (start/stop recording)

Start and stop recording using this button.

(This works together with the REC trigger button on the top and the lens VTR trigger button.)

When "SPLIT" is set for the 1394 REC TRIGGER item on the OTHERS[2/2] menu screen, this button becomes the start/stop recording button for an external device.

See page 97.

See "Backup Recording" on page 70.

16 [CH-1/CH-2 AUDIO LEVEL] CH-1/CH-2 Audio level controls and AUTO LED

Allow you to adjust the audio level for the CH-1 and CH-2 audio channels.

- To use these controls, set the CH-1/CH-2 AUDIO SELECT switch 2 on page 13 to "MANU".
- When the FULL AUTO switch 17 on page 19 or the CH-1/CH-2 AUDIO SELECT switch 2 on page 13 is set to "AUTO", "AUTO" LED lights. (The audio level controls do not work.)

17 [HDV/DV LED]

- In camera mode, this lights according to the setting for the video format being shot.
- In VTR mode, it lights according to the video format being recorded on tape or the IEEE1394 input video format.

HDV : Lights when the format is HDV.

DV : Lights when the format is DV.

HDV/DV : Turns off when the format is 1080i.

MEMO

- During a system error, HDV/DV flash alternately.
 - See page 108.
 - Select whether or not to have this light in the FORMAT LED item on the OTHERS[1/2] menu screen.
 - See page 96.
-

18 LCD door lock and release knob

To open the LCD door, move this knob on the direction toward the rear section.

19 LCD door

LCD monitor door.

The LCD monitor is located on the inner side of the door. The LCD monitor can be viewed when this door is opened.

The door can be turned to change the orientation of the LCD monitor, and it can be rotated so that it can be accommodated in the main body of the camera.

See page 50.

Left Side Section

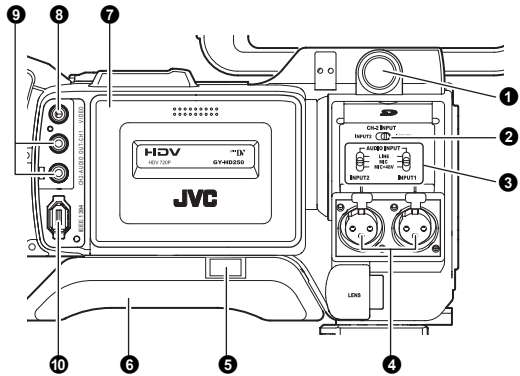

- 1 Viewfinder connector (6-pin)**
Connect the cable from the viewfinder here.
 - Set the image format for this terminal in VF SIGNAL on the LCD/VF[4/4] menu screen. See page 92.
- 2 [CH-2 INPUT] CH-2 audio input connector selector switch**
Selects the CH-2 audio input connector.
 - INPUT1 : Inputs the audio from the INPUT1 connector 4 into CH-2.
 - INPUT2 : Inputs the audio from the INPUT2 connector 4 into CH-2.

MEMO

The audio from the INPUT1 connector is also input into CH-1 regardless of the setting.

- 3 [AUDIO INPUT] Audio input signal selector switch**
This switch is used to select the input sound signal from INPUT1 or INPUT2 connector.
 - LINE : Set to this position when connected to audio equipment, etc. The reference input level is +4 dBs.
 - MIC : Set to this position when the dynamic microphone is connected.
 - MIC+48V : Set to this position when a microphone requiring +48 V power supply (phantom microphone, etc.) is connected.

CAUTION

When connecting a component that does not require +48 V power supply, make sure that the switch is not set to MIC+48V before the component is connected.

MEMO

You can select the normal input level for MIC and MIC+48V in the INPUT1, 2 MIC REF. item on the AUDIO/MIC[1/2] menu screen. See page 87.

- 4 [INPUT1/INPUT2] INPUT1/INPUT2 audio input connectors**
These are audio input connectors for connecting to an external audio device or microphone.
 - Set the [AUDIO INPUT] switch 3 according to the device to be connected.
 - Set the CH-2 audio input connector using the [CH-2 INPUT] switch 2.
 The CH-2 audio from the set connector is recorded.

- 5 Shoulder pad slide button**
Button to adjust the position of the shoulder pad. When you press this button, you can move the position of the shoulder pad 6 forward or backward.

- 6 Shoulder pad**

- 7 Cassette cover**
Sliding the EJECT switch 11 on page 18 located on the top section opens this cover to allow insertion or removal of the videocassette.

CAUTION

To prevent foreign objects from entering the internal parts of the VTR unit, do not leave this device with the cover open for extended periods of time.

- 8 [VIDEO OUT] Video output terminal (RCA)**
This is a terminal for composite video signal output.
 - Select whether or not to output a signal with setup in SET UP on the VIDEO FORMAT[2/2] menu screen. (Only for U model)

- 9 [AUDIO OUTPUT CH-1/CH-2] Audio output connector (RCA)**
Output connector for audio signals.
 - Outputs the input audio signal in the Camera mode.
 - Outputs the playback audio signal in the VTR mode.
 - When a HDV/DV signal (IEEE1394) is input, the EE sound of the input audio signal is output in the VTR mode.

MEMO

Alarm sound is not output.

- 10 [IEEE1394] IEEE1394 connector (6-pin)**
Using an IEEE1394 cable (optional), a digital video component with IEEE1394 connector can be connected here. See "Connecting the IEEE1394 Cable" on page 64. See "HDV/DV Dubbing" on page 68.

CAUTION

When connecting the IEEE1394 cable, confirm that the connector is facing the right direction before inserting. See page 64.

MEMO

Put the covers on the connectors when you are not using them.

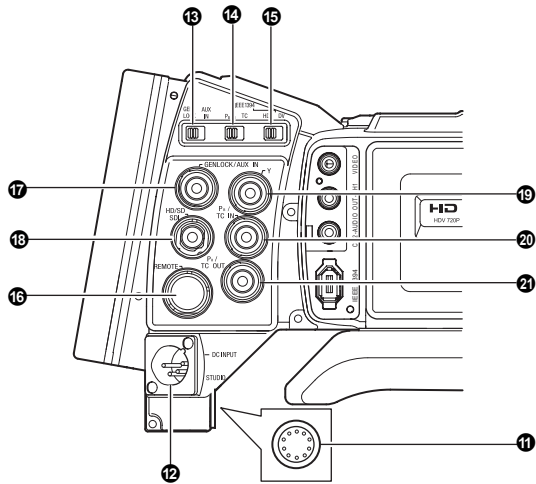

11 [STUDIO] Studio terminal (Round 10-pin)

Connect the studio cable from the KA-HD250 Studio Kit (sold separately). Connect the KA-HD250 to use this device as a studio camera.
For details, refer to the KA-HD250 INSTRUCTION MANUAL.

12 [DC INPUT] DC input terminal (XLR 4-pin)

This is the 12V DC power input terminal. Connect to the AC adapter.
When a battery is installed and a cable is connected to this terminal, power supply from the battery stops and power is supplied by this terminal.

13 [GENLOCK/AUX IN] GENLOCK/AUX IN switch

Set according to the signal input in the [GENLOCK/AUX IN] terminal.
GENLOCK : Set to this when inputting external synchronization signals.
AUX IN : Set to this when inputting composite video signals from an external device.

MEMO

If no signals are input to the [AUX IN] terminal and this switch is set to AUX IN, the monitor turns black and video is not output from any terminal.

14 [PbPr/TC] PbPr/Time code switch

Set according to the [Pb/TC IN] and [Pr/TC OUT] terminal signals.
PbPr : Set to this when outputting component Pb signals from the [Pb/TC IN] terminal and outputting component Pr signals from the [Pr/TC OUT] terminal.
TC : Set to this when inputting LTC time code from the [Pb/TC IN] terminal and outputting the built-in time code generator from the [Pr/TC OUT] terminal.

MEMO

When this switch is set to TC, video is not output from the Y/Pb/Pr terminal (19 20 21).

15 [IEEE1394] IEEE1394 switch

Set according to the image format of the input/output signal and playback signal of the IEEE1394 terminal.
HDV : Set to this for HDV format.
DV : Set to this for DV format.

16 [REMOTE] REMOTE terminal (Round 6-pin)

Some functions of this camera can be controlled externally.
Connect to a remote control unit (RM-LP55/RM-LP57).
See "Connect a Remote Control Unit (RM-LP55/RM-LP57)" on page 71.

17 [GENLOCK/AUX IN] GENLOCK/AUX IN terminal (BNC)

- Input synchronization signals in this terminal when externally synchronizing camera images or playback images.
Synchronization signal: BB (Black Burst) signal of SD or Tri sync signal of HD
- Input composite video signals to record images from an external device with this device.
- Select the signal to input with the [GENLOCK/AUX IN] switch 13.
- ☞ See "Using GENLOCK Functions" on page 66.
- ☞ See "Recording Composite Video Signals from an External Device" on page 65.

18 [HD/SD-SDI] HD/SD-SDI output terminal (BNC)

Outputs HD/SD-SDI (Serial Digital Interface) signals. Outputs embedded audio signals as digital audio.
The sampling frequency for embedded audio is 48 kHz.
In addition, the time code for the built-in time code generator and playback time code are output.
☞ See pages 20 and 21 for the signals that are enabled.

MEMO

Set whether or not to output SDI signals from this terminal in HD/SD-SDI OUT of the VIDEO FORMAT[2/2] menu screen.

19 [Y] Component Y signal output terminal (BNC)

Outputs Y signal of component when the [PbPr/TC] switch 14 is set to PbPr.

20 [Pb/TC IN] Component Pb signal output/time code input terminal (BNC)

- Outputs Pb signal of component when the [PbPr/TC] switch 14 is set to PbPr.
- Inputs time code when the [PbPr/TC] switch 14 is set to TC. Enter the LTC time code to slave lock this device's time code generator with an external time code generator.

MEMO

Set TCG SOURCE on the TC/UB/CLOCK Menu screen to EXTERNAL to input external time codes.
☞ See "Synchronizing with an External Time Code Generator" on page 49.

21 [Pr/TC OUT] Component Pr signal output/time code output terminal (BNC)

- Outputs Pr signal of component when the [PbPr/TC] switch 14 is set to PbPr.
- Outputs the LTC time code of the built-in time code generator when the [PbPr/TC] switch 14 is set to TC.

MEMO

Set the [Y/Pb/Pr] terminal (19 20 21) output image signal to RGB or Y/C video signals in OUTPUT TERM. [DV] on the VIDEO FORMAT[2/2] menu screen. (Only for DV format)
☞ See "OUTPUT TERM. [DV]" on page 79.

Top Section

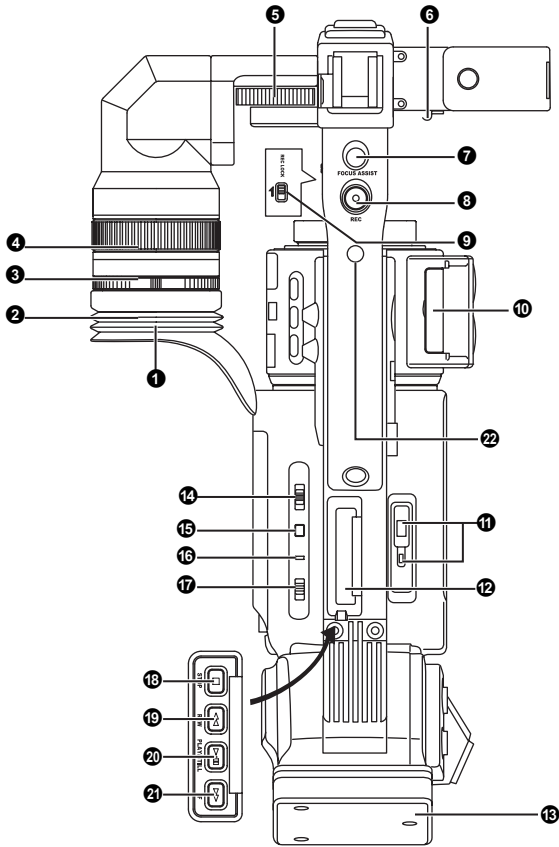

1 Viewfinder
Displays the camera image and the playback picture.

MEMO

Set the image format for the viewfinder to RGB, component, composite, or Y signal in VF SIGNAL on the LCD/VF[4/4] menu screen. See page 92.

2 Eyepiece
Ensures that ambient light does not reach the viewfinder screen or falls into the eye of the cameraman.

3 Eyepiece focus ring
You can adjust the focus by turning this ring.

4 Eyepiece mounting ring
You can adjust the position of the eyepiece forward or backward by loosening this ring.

5 Slide mounting ring
You can adjust the position of the viewfinder left or right by loosening this ring.

6 Clamp
Attach the microphone cable here.

7 [FOCUS ASSIST] Focus assist button
When you press this button during shooting, the area of focus is displayed in blue, red or green, making it easy to focus accurately.

MEMO

- When FOCUS ASSIST on the LCD/VF[1/4] menu screen is set to ACCU-FOCUS and this button is pressed, ACCU FOCUS functions with FOCUS ASSIST. This makes depth of field shallower, making it easier to focus.
- This button has the same function as the FOCUS ASSIST button 6 in the Right Side Section.

See "LCD/VF[1/4] Menu Screen" on page 89.

8 [REC] REC trigger button (start/stop recording)
Start and stop recording using this button.
(This works together with the REC trigger button on the right panel and the lens VTR trigger button.)

9 [REC LOCK] REC LOCK switch
Slide this switch in the direction of the arrow to lock the [REC] trigger button 8. Use this to prevent unwanted recording.
(The REC trigger button on the right panel and the lens VTR trigger button are not locked.)

10 SD memory card cover
When you open this cover, you can insert and remove the SD memory card.
See "Inserting an SD Memory Card" on page 34.
When an SD memory card is loaded

- You can save, call up and reset the menu settings on GY-HD250/GY-HD251.
- You can initialize (format) an SD memory card.

See "FILE MANAGE Menu Screen" on page 100.

11 [EJECT] Eject switch and LED
Slide this switch to the side to insert or eject a videocassette tape.
The LED lights while ejecting is in progress.

MEMO

- It takes a few seconds before the videocassette is ejected. Do not close the cassette cover during the eject operation.
- Do not touch the cassette insertion slot or cassette during the eject operation. This could result in damage.

12 Operation cover
Open this cover when operating in the playback mode. Otherwise, keep this cover closed.
This cover can be opened by sliding it to the side.

MEMO

When the STOP button 18 is pressed in the Camera mode to set the VTR operation mode indicator to indicate STOP, playback operations become possible.

13 Battery adapter
Attach the battery.
U model: Anton Bauer battery
E model: IDX battery
See "Battery Operation" on page 37.

14 [MONITOR SELECT] Audio monitor selector switch

This switch is used to select the monitor sound output and playback sound output from the monitoring speaker ① on page 14 or the PHONES jack ② on page 12.

CH-1 : The CH-1 channel audio is output.

BOTH : CH-1 and CH-2 channel audio are output mixed.

When this setting is selected, the menu screen can be used to select whether the mixed sound or stereo sound should be output via the PHONES jack. (AUDIO MONITOR item on the AUDIO/MIC[2/2] menu screen)

When AUDIO MONITOR item on the AUDIO/MIC[2/2] menu screen is set to "STEREO", only the audio of CH-1 is output from the monitoring speaker.

CH-2 : The CH-2 channel audio is output.

☞ See "Outputting Audio" on page 63.

☞ See "AUDIO/MIC[2/2] Menu Screen" on page 88.

CAUTION

Make sure to move switches all the way. Do not leave a switch stopped in a midway position. Noise will be generated and operation irregularities will occur.

15 [DISPLAY] Display button

- When LCD+VF in the LCD/VF[4/4] menu display is set to OFF, press the DISPLAY button for 2 seconds to switch between the LCD screen and the viewfinder screen.
- When LCD+VF in the LCD/VF[4/4] menu display is set to ON, press the DISPLAY button for 2 seconds to switch the LCD screen ON and OFF. Press the DISPLAY button briefly to change the display mode for the LCD screen as follows.

Only image displayed → Characters shown enlarged

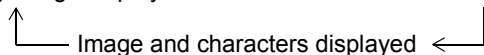

☞ See "Magnified Status Indications on the LCD Monitor" on page 29.

16 [VTR] VTR indicator

This indicator lights when the camera is in the VTR mode.

To perform VTR playback or to input the HDV/DV signal from the IEEE1394 connector ⑩ on page 16, press the CAM/VTR button ⑤ on page 13 to turn on this indicator.

It flashes when the mode is being changed.

17 [FULL AUTO] Full auto shooting (FAS) switch

This is the ON/OFF switch for FAS mode.

- During FAS mode, "FAS" is displayed on the LCD monitor or the viewfinder.
- FAS mode works together with the auto iris and auto level control (ALC) modes and automatically adjusts to the optimal video signal level and white balance.
- You can select automatic adjustment mode or manual adjustment mode for audio recording level.
☞ See "AUDIO/MIC[2/2] Menu Screen" on page 88.
- Even if there are color bars, this automatically sets to camera video.
- Auto iris mode operates even if the lens iris mode switch is set to the manual position.
- The gain changes continuously until it reaches the maximum ALC MAX setting, and the shutter speed also changes continuously.
- When you release FAS mode, all of the settings return to their previous modes.

CAUTION

When the power is turned on while the camera is in the FAS mode, it takes about 10 seconds before the automatic adjustment of FAS is completed.

All of the previous setting contents are recalled when the FAS mode is cancelled.

18 [STOP] Stop button

Press to enter the stop mode.

19 [REW] Rewind button

Press this button to rewind the tape.

- Pressing this button in the stop or fast forward mode initiates the rewind mode. (Only for VTR mode)
- Pressing this button during playback, still picture playback or forward search initiates reverse search.

20 [PLAY/STILL] Play/still button

Press to start playback. Press to enter the still picture mode during playback, in the stop mode or in the search mode.

Depending on the ambient temperature, if still image playback mode continues for between 30 seconds and 3 minutes, it stops automatically. (Tape protect mode)

During still picture playback and search mode, press this button to return to the normal playback mode.

* If the auto tracking is active at the moment the play mode is entered, the playback video will be interfered with digital noise.

21 [FF] Fast forward button

Press this button to fast forward the tape.

- Pressing this button in the stop or rewind mode initiates the fast forward mode. (Only for VTR mode)
- Pressing this button during playback, still picture playback or reverse search initiates forward search.

22 Screw holes for mounting accessories

You can mount lights and other accessories.

Recording and Image Output Formats

This device supports HDV and DV image formats, as well as images input from external devices. This device also has various output terminals. (Composite, analog component, HD/SD-SDI, IEEE1394)

Select analog component, RGB or Y/C signals for images from the Y/Pb/Pr terminal in DV format.

(Select in OUTPUT TERM. [DV] on the VIDEO FORMAT[2/2] menu screen)

During recording and playback, image formats from each of the output terminals are as shown in the table below.

Notes about the table

■ (Shaded): Indicates the setting item in the VIDEO FORMAT menu screen.

N/A: Terminal is not available.

← : Same format as the left.

■ When recording camera images

	Recording (Shooting)		Rec on Tape	IEEE 1394 Out	Component / SDI Out (EE Out)	RGB Out	Y/C Out	Composite Out
	[REC] menu item	Format						
HD (HDV)	HDV-HD60P	720/60p	←	←	←	N/A	N/A	480/60i
	HDV-HD30P	720/30p	←	←	720/60p	N/A	N/A	480/60i
	HDV-HD50P	720/50p	←	←	←	N/A	N/A	576/50i
	HDV-HD25P	720/25p	←	←	720/50p	N/A	N/A	576/50i
	HDV-HD24P	720/24p	←	←	720/60p	N/A	N/A	480/60i
DV	U model only	DV-60I	480/60i	←	←	←	←	←
		DV-24P	480/60i(24p)	←	←	←	←	←
		DV-24PA	480/60i(24p)	←	←	←	←	←
	E model only	DV-50I	576/50i	←	←	←	←	←
		DV-25P	576/50i(25p)	←	←	←	←	←
HD	[1080I CAMERA] menu item	Frame rate	Rec on Tape	IEEE 1394 Out	Component / SDI Out	RGB Out	Y/C Out	Composite Out
	ON	60/30	N/A	N/A	1080/60i	N/A	N/A	480/60i
		50/25	N/A	N/A	1080/50i	N/A	N/A	576/50i

■ In PLAY mode

	Playback	IEEE 1394 Out	Component / SDI Out					RGB Out	Y/C Out	Composite Out	
			[HDV PB OUTPUT] menu item								
			NATIVE	720P	1080I	NTSC	PAL				
HDV	720/60p	←	←	←	1080/60i	480/60i	N/A	480/60i ^{*1}	480/60i ^{*1}	480/60i	
	720/30p	←	720/60p	←	1080/60i	480/60i	N/A	480/60i ^{*1}	480/60i ^{*1}	480/60i	
	720/50p	←	←	←	1080/50i	N/A	576/50i	576/50i ^{*2}	576/50i ^{*2}	576/50i	
	720/25p	←	720/50p	←	1080/50i	N/A	576/50i	576/50i ^{*2}	576/50i ^{*2}	576/50i	
	720/24p	←	720/60p	←	1080/60i	480/60i	N/A	480/60i ^{*1}	480/60i ^{*1}	480/60i	
	480/60p	N/A	N/A	N/A	N/A	N/A	N/A	N/A	N/A	N/A	
	576/50p	N/A	N/A	N/A	N/A	N/A	N/A	N/A	N/A	N/A	
DV	U model	480/60i	←	←					←	←	←
		480/60i(24p)	←	←					←	←	←
	E model	576/50i	←	←					←	←	←
		576/50i(25p)	←	←					←	←	←

*1 When HDV PB OUTPUT is set to NTSC, 480/60i format video signal is output.

*2 When HDV PB OUTPUT is set to PAL, 576/50i format video signal is output.

MEMO

Synchronize the setting for FRAME RATE in the VIDEO FORMAT menu screen with the frame rate of the playback signal.

■ When Recording HDV or DV Images from the IEEE1394 Terminal

	Recording (IEEE1394 In)	Rec on Tape	Component / SDI Out					RGB Out	Y/C Out	Composite Out	
			[HDV PB OUTPUT] menu item								
			NATIVE	720P	1080I	NTSC	PAL				
HDV	720/60p	←	←	←	1080/60i	480/60i	N/A	480/60i ^{*1}	480/60i ^{*1}	480/60i	
	720/30p	←	720/60p	←	1080/60i	480/60i	N/A	480/60i ^{*1}	480/60i ^{*1}	480/60i	
	720/50p	←	←	←	1080/50i	N/A	576/50i	576/50i ^{*2}	576/50i ^{*2}	576/50i	
	720/25p	←	720/50p	←	1080/50i	N/A	576/50i	576/50i ^{*2}	576/50i ^{*2}	576/50i	
	720/24p	←	720/60p	←	1080/60i	480/60i	N/A	480/60i ^{*1}	480/60i ^{*1}	480/60i	
	480/60p	N/A	N/A	N/A	N/A	N/A	N/A	N/A	N/A	N/A	
	576/50p	N/A	N/A	N/A	N/A	N/A	N/A	N/A	N/A	N/A	
DV	U model	480/60i	←	←					←	←	←
		480/60i(24p)	←	←					←	←	←
	E model	576/50i	←	←					←	←	←
		576/50i(25p)	←	←					←	←	←

*1 When HDV PB OUTPUT is set to NTSC, 480/60i format video signal is output.

*2 When HDV PB OUTPUT is set to PAL, 576/50i format video signal is output.

MEMO

Synchronize the setting for FRAME RATE on the VIDEO FORMAT menu screen with the frame rate of the IEEE1394 input signal.

■ When Recording Composite Images from the AUX IN Terminal

	Recording (Composite In)	Rec on Tape	IEEE 1394 Out	Component/SDI Out (EE Out)	RGB Out	Y/C Out	Composite Out
HD							
SD	U model	480/60i	←	←	←	←	←
	E model	576/50i	←	←	←	←	←

MEMO

- For the U model, set REC on the VIDEO FORMAT[1/2] menu screen to DV-60I.
- For the E model, set REC on the VIDEO FORMAT[1/2] menu screen to DV-50I.

Indications on the LCD Monitor and in the Viewfinder

In addition to showing the EE image and the playback picture, the LCD monitor and viewfinder are also used for the following character displays. To show characters on the LCD monitor, press the DISPLAY button briefly.

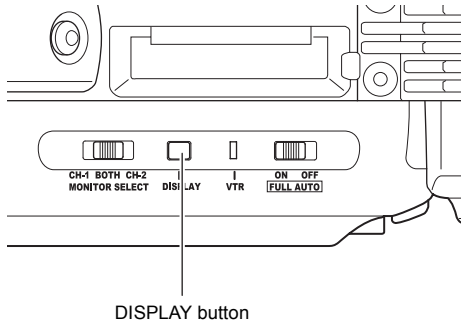

- Status screens (screens for checking the current camera settings)
- Auto white display (only displayed in the Camera mode)
- Menu setting screens
- Alarm message display
- Safety zone display (only displayed in the Camera mode)

MEMO

When ANALOG OUT CHAR. on the OTHERS[1/2] menu screen is ON, characters are also shown on images from the Y/Pb/Pr OUT and VIDEO OUT terminals. Characters are also shown on images from the HD/SD-SDI OUT terminal when the SDI OUT CHAR. is ON.

Status Screens

Press the STATUS button while normal screen is displayed to show one of the status screens.

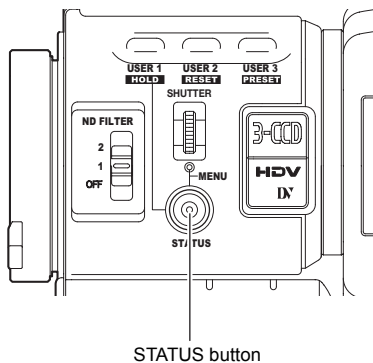

The contents of the status display are divided into those for the Camera mode and those for the VTR mode.

- Each time the STATUS button is pressed in the Camera mode, one of 5 status screens is displayed. (STATUS 0, 1, 2, 3, 4)
- One type of screen is displayed in the VTR mode.
- CAMERA MODE (display example)

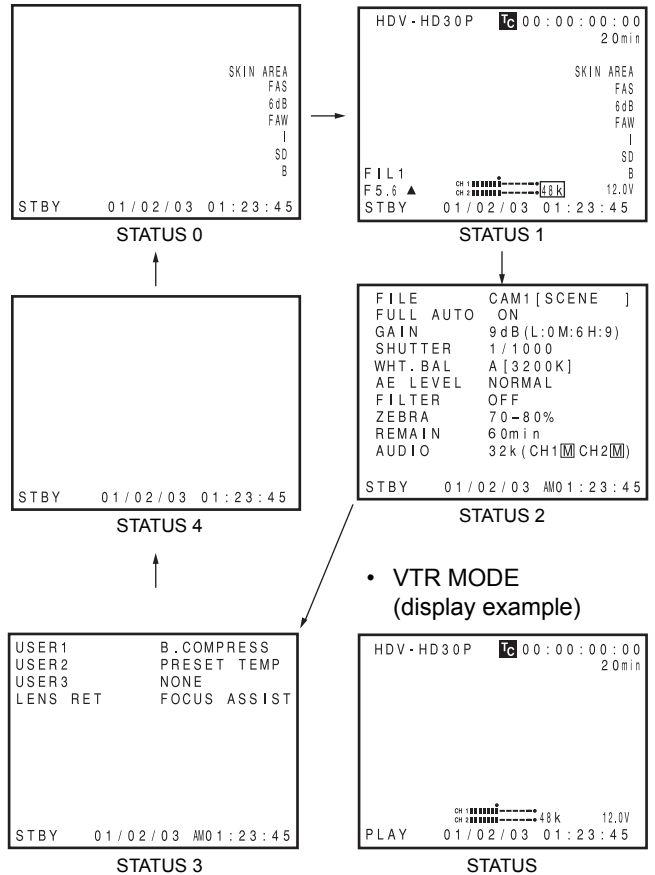

- VTR MODE (display example)

MEMO

- When the STATUS button is pressed for 1 second or longer, the menu setting screen is displayed. To display the Status screen while the menu setting screen is displayed, press the STATUS button to return to the normal screen.
- You can switch between the LCD monitor and the viewfinder by holding down the DISPLAY button for about 2 seconds. (When the LCD+VF item on the LCD/VF[4/4] menu screen is set to OFF.)

Status Screens in the Camera Mode

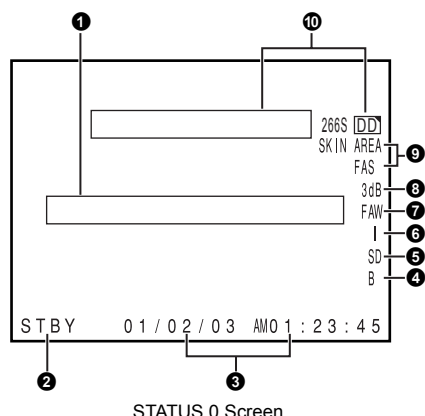

STATUS 0 Screen

External Image Input Mode (AUX IN)

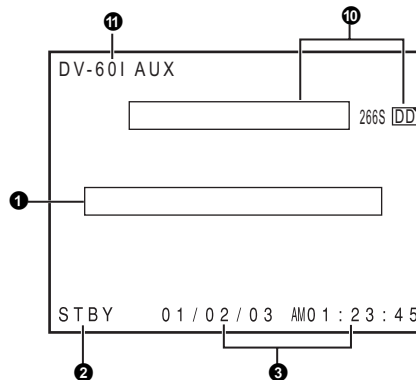

STATUS 0 Screen

STATUS 0

1 Event Indication

When the Gain or Shutter Speed is changed manually, the setting condition is displayed for about 3 seconds at the time the change is made.

- Set the shutter display method to seconds or angle in SHUTTER DISP. on the LCD/VF[3/4] menu screen. (Only when frame rate is 24p or 25p mode)

Setting Status	Contents of Indications
Gain value was changed	GAIN 0 dB, 3 dB, 6 dB, 9 dB, 12 dB, 15 dB, 18 dB
Gain value reached the ALC	GAIN ALC
FULL AUTO was turned ON/OFF	FULL AUTO ON, FULL AUTO OFF
ZEBRA was turned ON/OFF	ZEBRA ON, ZEBRA OFF
Shutter speed value was changed ^{*1} (When SHUTTER DISP. is set to SEC)	SHUTTER 1/6, 1/6.25, 1/7.5, 1/12, 1/12.5, 1/15, 1/24, 1/25, 1/30, 1/48, 1/50, 1/60, 1/100, 1/120, 1/250, 1/500, 1/1000, 1/2000, 1/4000, 1/10000
Variable shutter speed value was changed ^{*1} (When SHUTTER DISP. is set to SEC)	V. SHUTTER 1/24.01 to 1/10489.5
Shutter was turned OFF	SHUTTER OFF [1/**] ^{*4}
Shutter speed value was changed (When SHUTTER DISP. is set to DEG)	SHUTTER 360.0°, 180.0°, 172.8°, 150.0°, 144.0°, 135.0°, 120.0°, 105.0°, 90.0°, 75.0°, 60.0°, 45.0°, 30.0°, 22.5°, 11.2°
Variable shutter speed value was changed (When SHUTTER DISP. is set to DEG)	24p: 0.82° to 359.4° 25p: 0.85° to 359.4°
White balance value was changed	(Example) WHITE BAL A [3200K] Numeric value: Any of 2300, 2500, 2800, 3000, 3200, 3400, 3700, 4300, 5200, 5600, 6500, 8000
FILTER value was changed	FILTER OFF, FILTER ND 1 [1/4ND], FILTER ND 2 [1/16ND]
AE LEVEL value was changed ^{*2}	AE LEVEL -3, -2, -1, NORMAL, +1, +2, +3
BLACK gain value was changed ^{*2}	BLACK NORMAL BLACK STRETCH 1, 2, 3, 4, 5 BLACK COMPRESS 1, 2, 3, 4, 5
PRESET TEMP. value was changed ^{*2 *3}	WHITE BAL PRST [3200K], WHITE BAL PRST [5600K]
HEADER REC is running	HEADER REC
FOCUS ASSIST was turned ON/OFF	FOCUS ASSIST ON, FOCUS ASSIST OFF
Time code was set to zero reset	TC ZERO PRESET See page 45.
REC LOCK switch was turned ON/OFF	REC SWITCH LOCKED, REC SWITCH UNLOCKED See page 18, 9 REC LOCK switch.
A REC command was sent from the IEEE1394 connector	TRIGGER TO HDV, TRIGGER TO DV

Indications on the LCD Monitor and in the Viewfinder (Cont'd)

Setting Status	Contents of Indications
FF/REW button was pressed in CAMERA mode	SWITCH TO VTR MODE
REC/VTR trigger button was pressed when 1080I CAMERA in the VIDEO FORMAT[1/2] menu screen was set to ON	1080I REC INVALID
Other Displays	ⓘ See "FILE MANAGE Menu Screen" on pages 100-102. ⓘ See "Warnings and Responses" on page 106.

- *1 The range for the shutter speed differs depending on the video format setting. ⓘ See page 86.
- *2 Displayed if functions were assigned to the USER1 - 3 buttons. ⓘ See page 86.
- *3 Displayed when the [WHT.BAL] white balance selector switch 13 on page 15 is set to PRST (PRESET).
- *4 " ** " depends on the video format.

No.	Item	Contents
2	VTR mode indication	STBY : In record standby mode (record-pause mode) REC : During recording PLAY : During playback FF : During fast forward REW : During rewind STL : During still picture playback mode FWD : During playback in forward direction (FWD1: About ×2 speed, FWD2: About ×5 speed, FWD3: About ×10 speed) REV : During playback in reverse direction (REV1: About ×2 speed, REV2: About ×5 speed, REV3: About ×10 speed) STOP : Stop mode (Tape protect mode) EJECT : Cassette being ejected - - - : No tape loaded
3	Indication of date and time	Indicates the date and time. Whether or not the date and time should be displayed as well as the display style are set on the TIME/DATE menu.
	LCD BRIGHT indication	When the brightness of the monitor screen is adjusted with the LCD BRIGHT button, the date and time indications and the VTR mode indication 2 are turned off and the LCD BRIGHT indicator is displayed. (Example) BRIGHT +5■ Numeric value: Any of -5, -4, -3, -2, -1, 0, +1, +2, +3, +4, +5.
4	Indication of Black operation	B : Displayed when the black stretch or black compress settings are other than NORMAL.
5	Indication of skin tone detail color operation	SD : Indicated when skin tone detail is ON.
6	Indication of Iris level operation	I : Displayed when the AE LEVEL setting is other than NORMAL
7	Indication of FAW operation	FAW : Indicated when Full Auto White Balance is ON.
8	Gain operation indication	* dB : Indicates gain value when gain is other modes than 0 dB and ALC.
9	Indication of various function operations	FOCUS : Displayed when the Focus Assist function is ON. SKIN AREA : Blinks while the skin detail color area is displayed. ALC : Displayed when ALC function alone is ON. FAS : Displayed when the Full Auto Shooting function is ON. S : Displayed when the shutter speed is a setting other than the default setting. ⓘ See page 86.
10	Indication of DR-HD100 Operation	When a DR-HD100 (HDD unit by FOCUS enhancements) is connected, its operation status is displayed. □: DR-HD100 is connected (displays white) □: Recording with DR-HD100 (displays red) (For details, refer to the DR-HD100 INSTRUCTION MANUAL.)
11	AUX display	Displays when in external image input mode. (AUX IN mode)

External Image Input Mode (AUX IN)

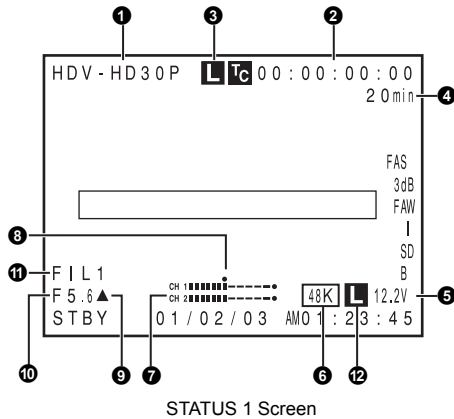

STATUS 1 Screen

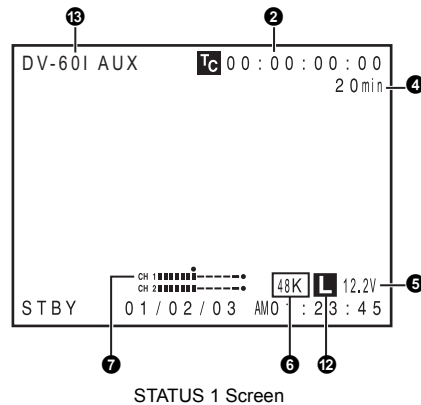

STATUS 1 Screen

STATUS 1

In addition to the information on the STATUS 0 screen, this screen displays the following items.

No.	Item	Contents
①	VIDEO FORMAT display	Displays the currently selected video format. Allows you to select the REC item on the VIDEO FORMAT[1/2] menu screen. See page 77. You can switch this display ON/OFF using the VIDEO FORMAT item on the LCD/VF[3/4] menu screen. See page 91.
②	Time Code (TC)/User's Bits (UB) indication	Indicates the time code (h:m:s:frame) or user's bits data. (Example) Time code TC 00 : 00 : 00 : 00 <div style="margin-left: 150px;"> 00 </div> <div style="margin-left: 100px;"> Colon (:) when non-drop frame mode Dot (.) when drop frame mode </div> User's bits UB FF EE DD 20 Whether or not to display this item is set with the TC/UB item on the LCD/VF[3/4] menu screen. See page 91. Whether the time code or user's bits should be shown is selected with the TC DISPLAY switch inside the LCD door.
③	Synchronized display with an external time code generator	Lights up when the time code generator of this device synchronizes with the time code input from the TC IN terminal. Blinks when synchronization is unsuccessful. Turns off if there is no input signal.
④	Remaining tape indication	Remaining tape indication (displayed in 1-minute steps) This indicator blinks when remaining tape time is equivalent to less than 3 minutes. Whether or not to display this item is set with the TAPE REMAIN item on the LCD/VF[3/4] menu screen. See page 91. * When inserting a brand-new tape, the remaining tape time is not indicated. When the tape has been run, the indication will appear. * The remaining tape indication is to be regarded only as a guide. * When this device is used at low temperatures, it may take a while before the indication of the remaining tape time appears.
⑤	Voltage indication	(Example) 12.2V: Indicates remaining battery level in 0.1V steps. Battery voltage and remaining battery are displayed. Select the display method in BATTERY INFO. on the LCD/VF[3/4] menu screen. See page 91. Anton Bauer battery: Voltage/remaining capacity (%) / remaining time IDX Endura battery : Voltage/remaining capacity (%)

Indications on the LCD Monitor and in the Viewfinder (Cont'd)

No.	Item	Contents
⑥	Audio sampling frequency indication	<p>32 K : Indicated when the AUDIO MODE item on the AUDIO/MIC[1/2] menu screen is set to 32 K. (Audio is recorded with 12-bit, 32 kHz sampling.)</p> <p>48 K : Indicated when the AUDIO MODE item on the AUDIO/MIC[1/2] menu screen is set to 48 K. (Audio is recorded with 16-bit, 48 kHz sampling.) When HDV format is set, 48K is displayed.</p> <p>☞ See page 87.</p> <p>Whether or not to display this item is set with the AUDIO item on the LCD/VF[3/4] menu.</p>
⑦	Audio level meter indication	<p>Displays the CH-1, CH-2 audio level meters.</p> <p>Whether or not to display this item is set with the AUDIO item on the LCD/VF[3/4] menu.</p> <p>☞ See page 91.</p>
⑧	Standard audio level indication	<p>The level at which audio is recorded on the tape is indicated by "■".</p> <p>-20 dB, -12 dB</p> <p>☞ See "AUDIO REF.LEVEL" on page 87.</p>
⑨	Iris indicator display	<p>▲ : Iris set higher than normal</p> <p>■ : Iris set to normal</p> <p>▼ : Iris set lower than normal</p> <p>The indication can be switched ON/OFF with the F.NO/IRIS IND. item on the LCD/VF[1/4] menu screen.</p> <p>☞ See page 89.</p>
⑩	Iris F-value indication	<p>Indicates the F-number of the connected lens.</p> <p>OPEN, F2, F2.8, F4, F5.6, F8, F11, F16, CLOSE</p> <p>It is not displayed when the lens is removed. For some lenses, no display appears.</p> <p>The indication can be switched ON/OFF with the F.NO/IRIS IND. item on the LCD/VF[1/4] menu screen.</p> <p>☞ See page 89.</p>
⑪	Filter position indication	<p>Indicates the current filter position.</p> <p>No display : FILTER OFF</p> <p>ND1 : FILTER ND1 (1/4ND)</p> <p>ND2 : FILTER ND2 (1/16ND)</p> <p>The indication can be switched ON/OFF with the FILTER item on the LCD/VF[1/4] menu screen.</p> <p>☞ See page 89.</p>
⑫	Audio Lock Indication	Displayed when the audio signal is locked to the video signal.
⑬	AUX display	Displays when in external image input mode (AUX IN mode)

FILE	CAM1 [SCENE]
FULL AUTO	ON
GAIN	9dB (L:0M:6H:9)
SHUTTER	1 / 1000
WHT. BAL	A [3200K]
AE LEVEL	NORMAL
FILTER	OFF
ZEBRA	70-80%
REMAIN	60min
AUDIO	32k (CH1 <input type="checkbox"/> CH2 <input type="checkbox"/>)
STBY	01 / 02 / 03 AM01 : 23 : 45

STATUS 2 Screen

USER1	B.COMPRESS
USER2	PRESET TEMP
USER3	NONE
LENS RET	FOCUS ASSIST
STBY	01 / 02 / 03 AM01 : 23 : 45

STATUS 3 Screen

STATUS 2

This screen displays the camera setup statuses.
Event display is not available while this screen is displayed.

Indication	Indication Contents
FILE	FILE ● CAM1 [*****], CAM2-4 [*****], and EXT1 - 4 [*****] * indicates SUB NAME See pages 100-102. A ● symbol is displayed when a menu setting read from LOAD FILE was changed. The display disappears when the setting is saved using STORE FILE.
FULL AUTO	ON, OFF
GAIN	0dB, 3dB, 6dB, 9dB, 12dB, 15dB, 18dB, ALC
SHUTTER*	(When STEP is selected) OFF, 1/6, 1/6.25, 1/7.5, 1/12, 1/12.5, 1/15, 1/24, 1/25, 1/30, 1/48, 1/50, 1/60, 1/100, 1/120, 1/250, 1/500, 1/1000, 1/2000, 1/4000, 1/10000 (When VARIABLE is selected) 1/24.01 - 1/10489.5 (Displayed when FAS or ALC mode is selected) EEI * The range for the shutter speed differs depending on the video format. See page 86.
WHT. BAL	A[##00K], B[##00K], PRESET[##00K], FAW, MANUAL (Only when the remote control unit is used) For A and B, ## represents 23, 25, 28, 30, 32, 34, 37, 43, 52, 65, or 80. For PRESET, 32 or 56.
AE LEVEL	-3, -2, -1, NORMAL, +1, +2, +3
FILTER	OFF, ND1 [1/4ND], ND2 [1/16ND]
ZEBRA	60-70%, 70-80%, 85-95%, OVER 95%, OVER 100%
REMAIN	Displays the remaining tape (minutes)
AUDIO	Displays the audio sampling frequency and the audio level adjustment mode (Ex: 32K (CH1 <input type="checkbox"/> CH2 <input type="checkbox"/>) <input type="checkbox"/> (for AUTO mode) <input type="checkbox"/> (for MANUAL mode)

* When SHUTTER DISP. on the LCD/VF[3/4] menu screen is set to DEG, the shutter display for the frame rate in 24p or 25p mode is degrees.

Indication	Indication Contents
SHUTTER	(When STEP is selected) 360.0°, 180.0°, 172.8°, 150.0°, 144.0°, 135.0°, 120.0°, 105.0°, 90.0°, 75.0°, 60.0°, 45.0°, 30.0°, 22.5°, 11.2° (When VARIABLE is selected) 24p: 0.82° to 359.4°, 25p: 0.85° to 359.4°

STATUS 3

Displays a list of setting statuses for USER1, 2, and 3 as well as LENS RET item on the SWITCH MODE menu screen.
 See page 86.
Events are not displayed while these statuses are being displayed.

Indication	Indication Contents
USER1 USER2	NONE, BARS, PRESET TEMP., B.STRETCH1 to 5, B.COMPRESS1 to 5, AE LEVEL+, AE LEVEL-, RET, LOAD FILE
USER3	NONE, BARS, PRESET TEMP., B.STRETCH1 to 5, B.COMPRESS1 to 5, RET, LOAD FILE
LENS RET	RET, FOCUS ASSIST

STATUS 4

This screen only displays VTR mode indication, date and time, event display and alarm indications.
* Whether or not date and time should be displayed and the display style are set on the TIME/DATE menu screen.
 See "Displaying the Time and Date on the Screen" on page 42.

Indications on the LCD Monitor and in the Viewfinder (Cont'd)

Status Screen in VTR MODE

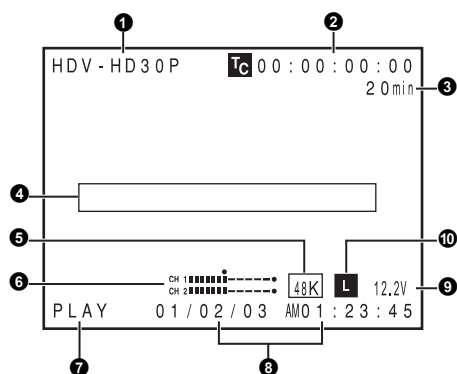

No.	Item	Contents
①	VIDEO FORMAT display	Displays the video format recorded on the tape when in VTR mode. Also displays the video format of the HDV/DV input signal. You can switch this display ON/OFF using the VIDEO FORMAT item on the LCD/VF[1/2] menu screen. ☞ See page 91.
②	Time code (TC) and user's bits (UB) display	Displays the time code data being recorded (hour, minute, second, frame) when in VTR mode. You can switch this display ON/OFF using the TC/UB item on the LCD/VF[1/2] menu screen. ☞ See page 91. You can select to display either the time code or the user's bits using the TC DISPLAY switch in the LCD door.
③	Remaining tape time	Remaining tape indication (displayed in 1-minute steps) This indicator blinks when remaining tape time is equivalent to less than 3 minutes. Whether or not to display this item is set with the TAPE REMAIN item on the LCD/VF[1/2] menu screen. ☞ See page 91. * When inserting a brand-new tape, the remaining tape time is not indicated. When the tape has been run, the indication will appear. * The remaining tape indication is to be used only as a guide. * When this device is used at low temperatures, it may take a while before the indication of the remaining tape time appears.
④	Event display	Displays messages related to VTR operations. ☞ See pages 106-108.
⑤	Audio sampling frequency indication	The audio sampling frequency used for the recording is displayed during playback. (32 K, 48 K, 44.1 K) Whether or not to display this item is set with the AUDIO item on the LCD/VF[1/2] menu screen. ☞ See page 91.
⑥	Audio level meter indication	Displays the audio level meters during playback. Whether or not to display this item is set with the AUDIO item on the LCD/VF[1/2] menu screen. ☞ See page 91.
⑦	VTR mode indication	Indicates the VTR operation status STBY, STOP, PLAY, REC, FF, REW, FWD, REV, STL, --- (No tape loaded), SLOW: During variable playback in forward direction (Displayed when using non-linear editing software.) (SLOW+1: About ×0.1 speed, SLOW+2: About ×0.2 speed, SLOW+3: About ×0.5 speed) During variable playback in reverse direction (Displayed when using non-linear editing software.) (SLOW-1: About ×-0.1 speed, SLOW-2: About ×-0.2 speed, SLOW-3: About ×-0.5 speed)

No.	Item	Contents
8	Time/Date indication	Recorded data are displayed during playback, fast forward, and rewind. During recording in DV format, the data from the IEEE1394 connector is displayed. During recording in HDV format, the data of internal clock is displayed. Whether or not the date and time should be displayed and the display style are set on the TIME/DATE menu screen. See page 95. When the date and time have not been set, the following indication appears. --/-/-- --:--:--
9	Voltage indication	(Example) 12.2V : Indicates remaining battery level in 0.1V steps. Battery voltage and remaining battery are displayed. Select the display method in BATTERY INFO. on the LCD/VF[1/2] menu screen. See page 91. Anton Bauer battery: Voltage/remaining capacity (%)/remaining time IDX Endura battery : Voltage/remaining capacity (%)
10	Audio Lock indication	Displayed when the audio signal from DV recording or playback is locked to the video signal.

Magnified Status Indications on the LCD Monitor

The characters on the status screens can be showed alone in magnified size on the LCD monitor.

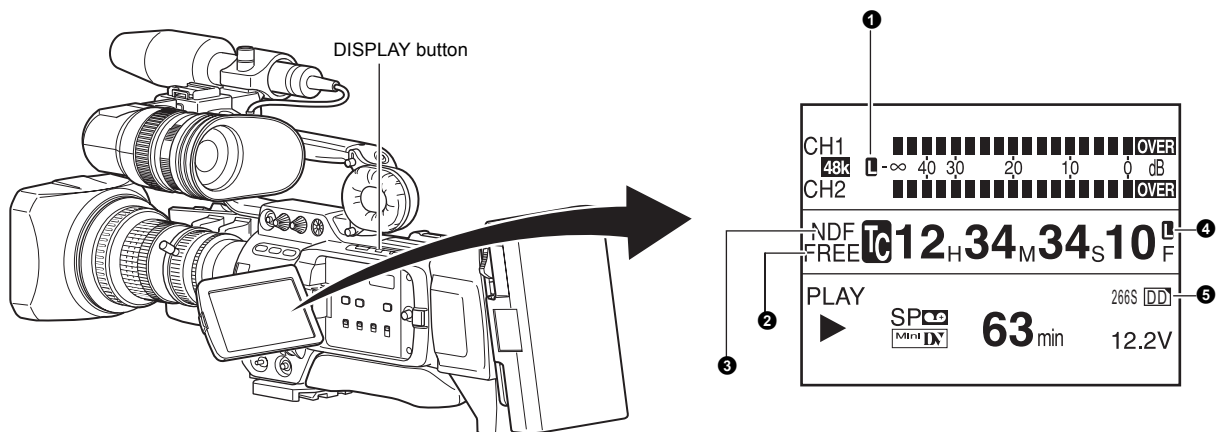

1. Set the LCD+VF item on the LCD/VF[4/4] menu screen to ON. See page 92.
2. When the DISPLAY button is briefly pressed while the LCD monitor is displayed, the displayed contents change every time the DISPLAY button is pressed.

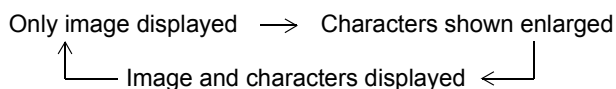

No.	Item	Contents
1	Audio Lock Indicator	Displayed during recording and playback when the audio signal is locked to the video signal.
2	Time Code Generator Setting Indicator	Indicates the set status of the TC GENE switch on the side section. FREE : TC GENE switch is set to PRESET-FREE RUN MODE. RECR : TC GENE switch is set to PRESET-REC RUN MODE. REGN : TC GENE switch is set to REGEN MODE. DUPL : There is 1394 input in VTR mode and TC DUPLI. menu is set to ON. EXT : Displays when time code is input to the TC IN terminal. (When TCG SOURCE on the TC/UB/CLOCK menu screen is set to EXTERNAL.)
3	Drop/Non-drop Indicator	Indicates the framing mode of the time code. DF : Drop frame mode NDF : Non-drop frame mode
4	Synchronized display with an external time code generator	Lights up when the time code generator of this device synchronizes with the time code input from the TC IN terminal. Blinks when synchronization is unsuccessful. Turns off If there is no input signal.
5	Indication of DR-HD100 Operation	When a DR-HD100 (HDD unit by FOCUS enhancements) is connected, its operation status is displayed. (For details, refer to the DR-HD100 INSTRUCTION MANUAL.)

MEMO

When characters indicating the status are displayed in magnified size on the LCD monitor, the viewfinder display the image.

Indications on the LCD Monitor and in the Viewfinder (Cont'd)

Auto White Balance Indication (Camera mode only)

The AUTO WHITE indication and the result of the operation are displayed during the auto white balance adjustment operation.
 See "White Balance Adjustment" on page 52.

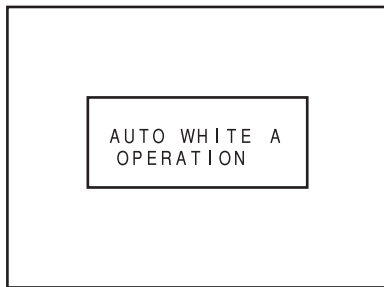

Alarm Message Display

- The following alarm messages are displayed while the STATUS (0, 1, 4) screen is shown in the Camera mode, or a STATUS screen is shown in the VTR mode. If an alarm is generated while the STATUS 2, 3 screen is shown, the STATUS 0 screen returns to display the alarm.
 See page 106.
- When an abnormality occurs in the VTR, a warning message with an error code is displayed.
 See pages 106-108.

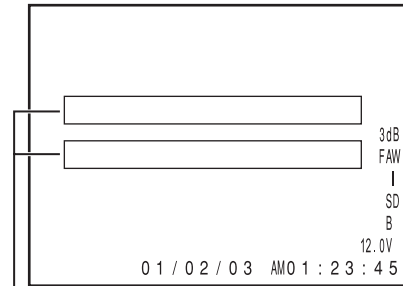

Alarm display area

Menu Setting Screen

Screen used for making various settings. The Menu Setting Screen appears when the STATUS button is pressed for 1 second or more.
 See "Setting Menu Screens" on page 75.

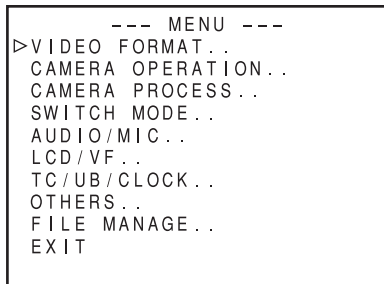

TOP MENU screen (Camera mode)

Safety Zone Indication (Camera mode only)

The indication of the following safety zone and center mark indications can be turned ON/OFF with the SAFETY ZONE item and CENTER MARK item on the LCD/VF[1/4] menu screen. See page 89. In addition, the safety zone display is on or off depending on the REC item setting and the ASPECT item setting in the VIDEO FORMAT menu screen, as shown below.

SAFETY ZONE		OFF	4:3		14:9		16:9		16:9+4:3	
CENTER MARK		-	OFF	ON	OFF	ON	OFF	ON	OFF	ON
REC	ASPECT								Cannot be selected	
DV-60I DV-50I DV-24P DV-24PA DV-25P	4:3	[]	[]	[+]	[]	[+]	[]	[+]		
	16:9	[]	[]	[+]	[]	[+]	[]	[+]		
HDV-HD60P HDV-HD50P HDV-HD30P HDV-HD25P HDV-HD24P	[16:9]	[]	[]	[+]	[]	[+]	[]	[+]	[]	[+]

SAFETY ZONE		2.35:1CE		2.35:1CH	
CENTER MARK		OFF	ON	OFF	ON
DV-60I DV-50I DV-24P DV-24PA DV-25P	4:3	Cannot be selected			
	16:9				
HDV-HD60P HDV-HD50P HDV-HD30P HDV-HD25P HDV-HD24P	[16:9]				

Switching between the LCD Screen and Viewfinder Display

■ When the LCD+VF item in the LCD/VF[4/4] menu is set to OFF, the LCD monitor and viewfinder (VF) displays are as shown below.

LCD Monitor Status		LCD Display	VF Display
LCD Closed	Normal LCD	OFF	ON
	Inverted LCD	ON	OFF
LCD Open	Normal LCD	ON	OFF
	Inverted LCD	ON	OFF

MEMO

- You can switch between the LCD monitor and the viewfinder by holding down the DISPLAY button for about 2 seconds.
- After you set up the function that switches the display between the LCD monitor and the viewfinder by holding down the DISPLAY button, the display mode is cancelled by the LCD monitor open/close and normal/inverted operations.
- If the LCD monitor is closed inside this device with the screen in the normal display orientation, holding down the DISPLAY button does not work.

■ When the LCD+VF item in the LCD/VF[4/4] menu is set to ON, the LCD monitor and viewfinder (VF) displays are as shown below.

LCD Monitor Status		LCD Display	VF Display
LCD Closed	Normal LCD	OFF	ON
	Inverted LCD	ON	ON
LCD Open	Normal LCD	ON	ON
	Inverted LCD	ON	ON

MEMO

- Press the DISPLAY button for 2 seconds to switch the LCD screen display ON and OFF.
- The viewfinder screen is always displayed.

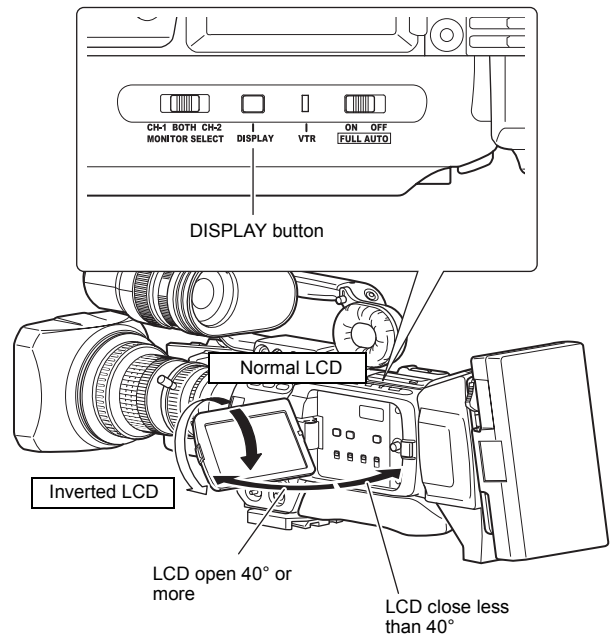

Basic System

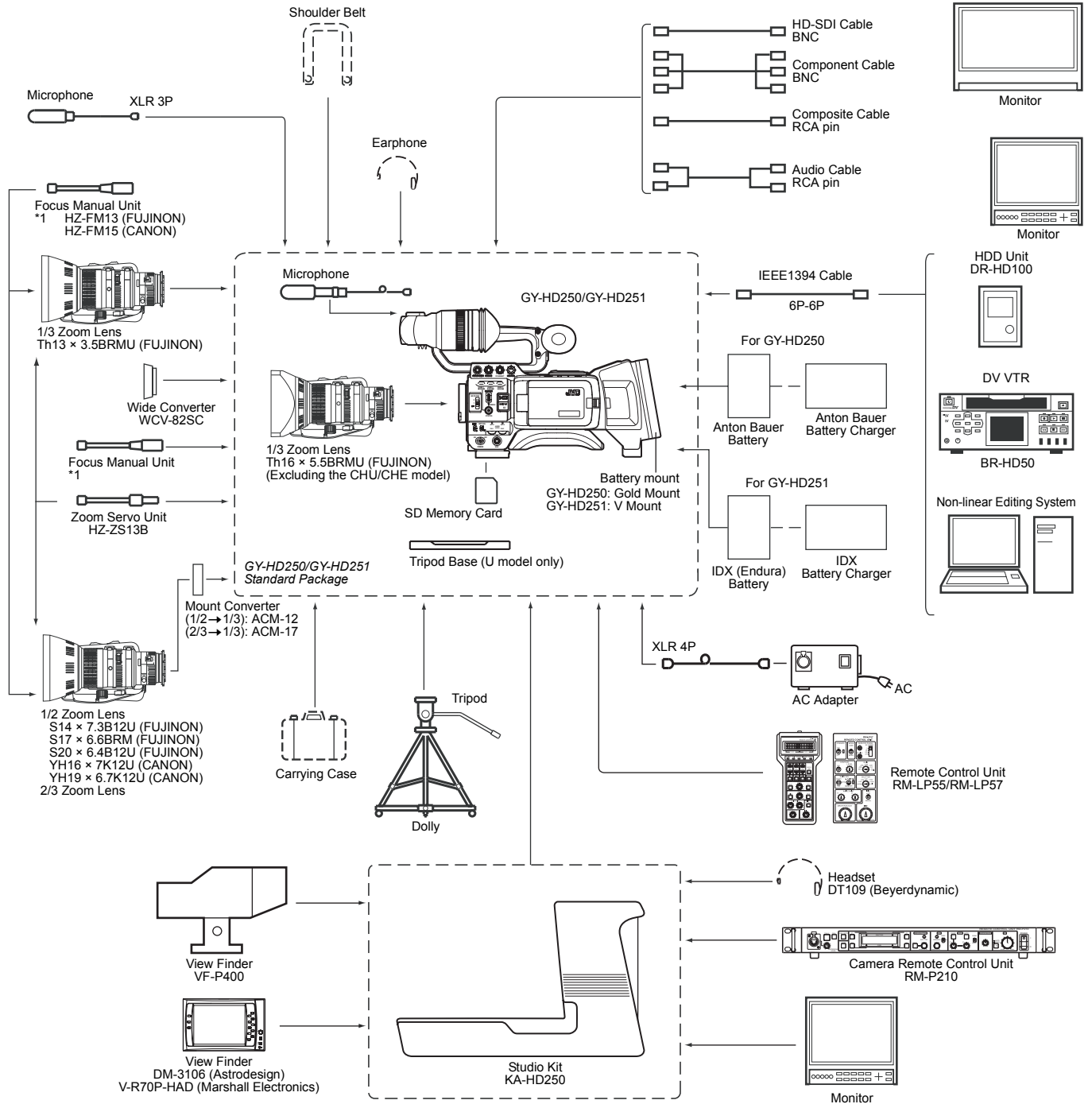

*1 An HZ-FM13 cannot be used with a Th16 × 5.5BRMU or S14 × 7.3B12/U zoom lens. Use a FUJINON focus manual unit (FMM-8, CFH-3, CFC-12-990). For details, please consult your JVC authorized dealer.

Attaching the Zoom Lens

1. Loosen the mount ring.
2. Attach the lens with its pin aligned with the hole in the mount.
3. Tighten the mount ring.
4. Connect the cable connector.
5. Clamp the lens cable.

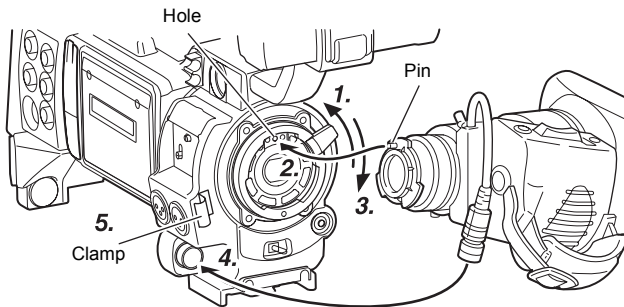

CAUTION

- Be sure to tighten the mount ring completely. Incomplete tightening may result in the lens dropping off or disturbed back focus.
- Set the GY-HD250/GY-HD251's power switch to "OFF" before the zoom lens is attached or detached.

Attaching the Microphone (Provided)

Connect the provided microphone to the microphone holder. Provided microphone is a phantom microphone.

1. Turn the knob on the microphone holder anticlockwise to loosen it and open the microphone holder.
2. Place the microphone in the microphone holder. Place the microphone toward the front to prevent it from interfering with the cassette cover.
3. Turn the knob on the microphone holder clockwise to secure the microphone.
4. Connect the microphone cable to the INPUT1 or INPUT2 input connector on the GY-HD250/GY-HD251.
5. Attach the microphone cable to the clamp.
6. Make sure to perform the correct setting for use of a phantom microphone.
☞ See page 56.

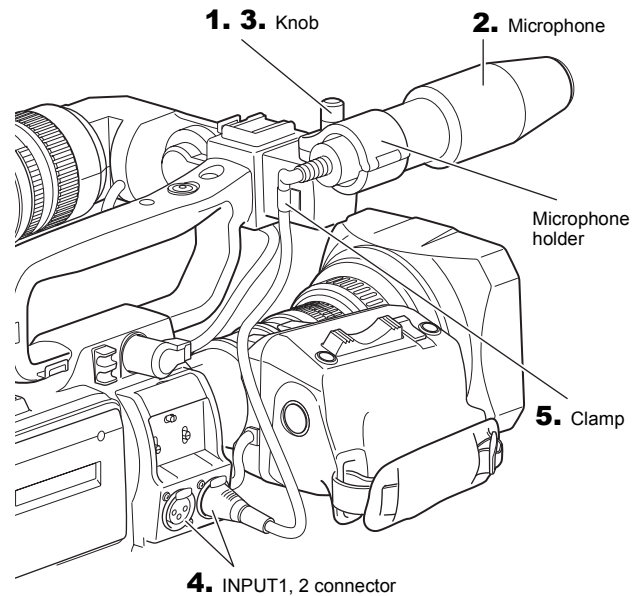

How to Attach the Viewfinder

1. To attach the viewfinder, slide it in the direction of the arrow.
 2. Set the viewfinder to a comfortable position and then turn the slide mounting ring and mount.
- To take off the viewfinder, pull the knob in the direction of the arrow as you slide the viewfinder.

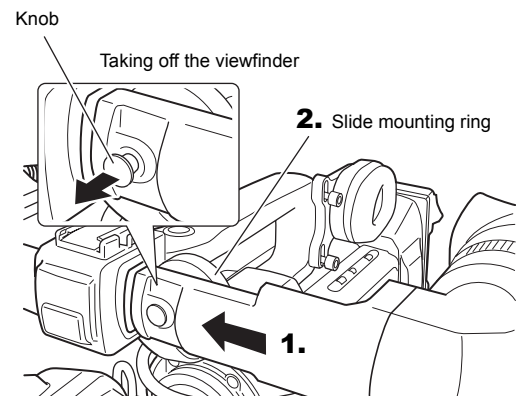

PREPARATIONS

About the Viewfinder Cable

Attach the viewfinder cable to the clamp ⑦ on page 14. To reduce the emission of unwanted radio waves, be sure to attach the provided core filter as shown in the figure below.

- Attach the core filter (black) as close to this device as possible, as shown in the figure.

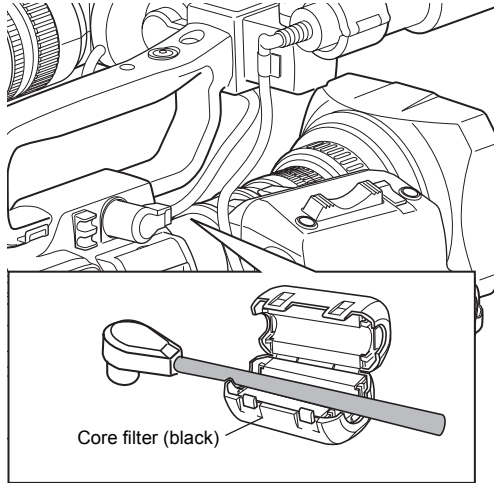

Inserting an SD Memory Card

By using an SD memory card, you can save and call up menu settings and camera settings for GY-HD250/GY-HD251.

- ☞ See "FILE MANAGE Menu Screen" on page 100.

Check that the POWER switch is OFF.

Inserting an SD Memory Card

1. Open the SD memory card cover.
2. Face the cutout end of the SD memory card inward and insert it in the direction of the arrow.

CAUTION

Be sure not to touch the metal connector area of the SD memory card.

3. Close the SD memory card cover.

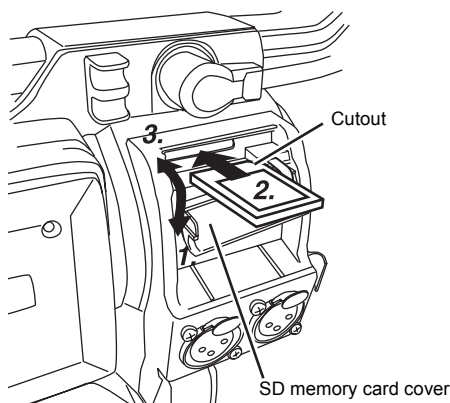

Taking out the SD memory card

1. Push the SD memory card in the direction of the arrow.
 - The SD memory card comes out slightly.
2. Pull the SD memory card straight out.

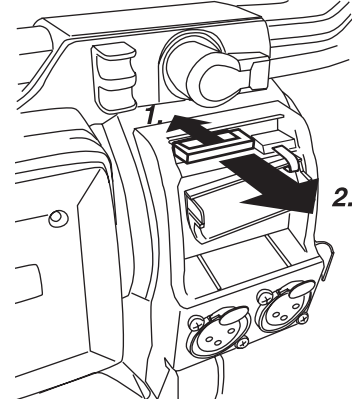

About SD Memory Cards

- When you use an SD memory card that was either just purchased or formatted on a device other than GY-HD250/GY-HD251, format it on GY-HD250/GY-HD251.
 - ☞ See page 102.
- Recommended SD memory cards
Panasonic: 16 MB to 2 GB
- You can write-protect the card so that saved files are not mistakenly erased. Set the switch on the side of the SD memory card to the "LOCK" position.

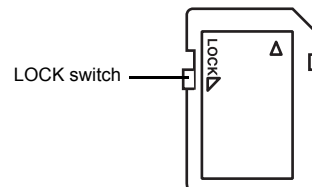

MEMO

SDHC-compliant memory cards cannot be used with this device.

Attaching the Tripod Base (Provided only for U model)

Use the provided tripod base to place the camera on a tripod. (U model only)

1. Attach the tripod base on the tripod by using the hole that balances this device most optimally.

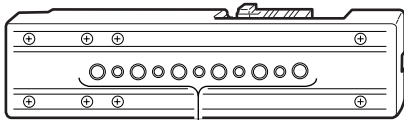

1. Tripod mounting holes

2. While pushing the safety lever, pull the lock lever toward the front until the front mount clip clicks into place.

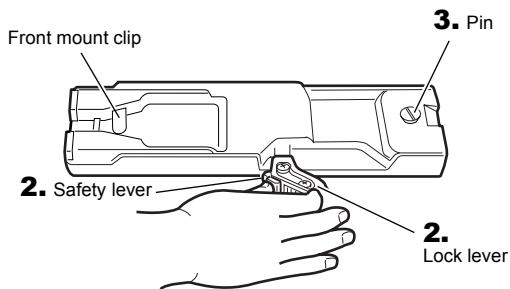

3. Place this device on the tripod base by aligning the rear base mount of this device with the pin on the tripod base.

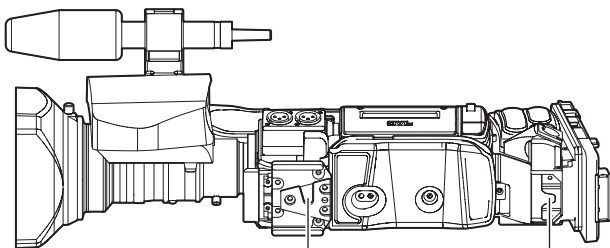

4. Front base mount

3. Rear base mount

4. Hold the camera on the top and slide forward so that the base mount of the camera is locked by the front mount clip of this device as it clicks into place.

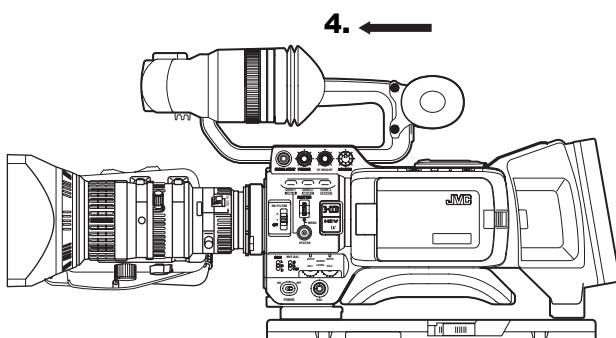

CAUTION

- The front base mount may be locked while the pin of the tripod base is not inserted into the hole on the rear base mount of this device. Therefore, after mounting, make sure that these parts are engaged properly.
- When moving this device mounted on a tripod, any impact or vibration should be avoided as this may cause this device to become detached and to drop from the tripod.
Be sure to remove this device from the tripod before transporting it.

AC Operation

The GY-HD250/GY-HD251 is operable with AC power supply or battery pack.

Use the AC adapter as the AC power supply.

1. After making sure that the power switches of the GY-HD250/GY-HD251 and of the AC adapter are set to OFF, connect the DC cable to the DC OUTPUT connector of the AC adapter and the DC INPUT connector of the GY-HD250/GY-HD251 as shown in the illustration.
 - To lessen the amount of unnecessary radio waves emitted, attach a provided Clamp filter near both ends of the DC cable as shown in the diagram.

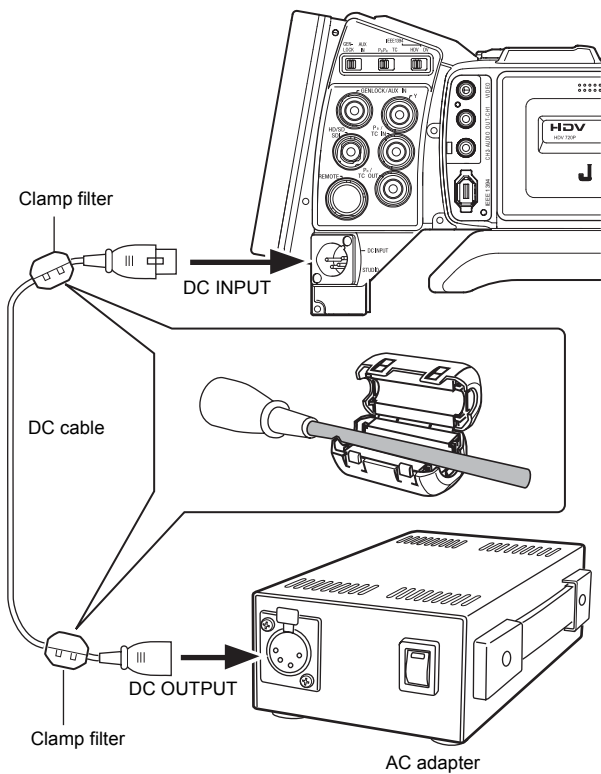

2. Press the POWER switch of the GY-HD250/GY-HD251 to ON. Power is supplied to the VTR section and the camera.

CAUTION

- Do not remove or connect the DC cable while recording is being performed.
- Do not use any power source with large fluctuations in the power source voltage, power sources generating noise, such as ripples or power sources with lower voltage.

Charging the Built-in Battery

The built-in, rechargeable backup battery retains the date and time and the time code data.

The built-in battery is constantly being charge whenever the GY-HD250/GY-HD251 is connected to a power supply, but it gradually discharges while the GY-HD250/GY-HD251 is disconnected from a power supply. The battery will be fully discharged when the GY-HD250/GY-HD251 is not used for about three months, in which case the set date and time and time code data are reset.

In this case, recharge the built-in battery and then set the date and time and time code data again.

However, it is possible to use the GY-HD250/GY-HD251 even if the built-in battery is discharged but the date and time and time code data cannot be recorded.

How to charge the built-in battery

1. Connect the AC adapter to the GY-HD250/GY-HD251 and an AC outlet or mount a charged battery on the GY-HD250/GY-HD251.
2. Set the POWER switch on the GY-HD250/GY-HD251 to "ON" or "OFF" (charging takes places with the POWER switch set to either of the positions).
3. Leave the equipment in this condition for about 4 hours.
 - The built-in battery will remain charged for about 3 months after being charged for about 4 hours.

Battery Operation

The attachable battery varies depending on location.

Recommended batteries

U model: Dionic 90 (Anton Bauer)

E model: Endura-7 (IDX)

CAUTION

Use only the recommended batteries.

If a heavy battery is used, the battery may fall out depending on the way the HD camera recorder is used.

■ GY-HD250U

Use an Anton Bauer battery.

Attaching the Battery

1. Align the battery guide pins (three places) with the battery adapter guide holes and insert straight. Battery will not be properly attached if guide pins are not straight.

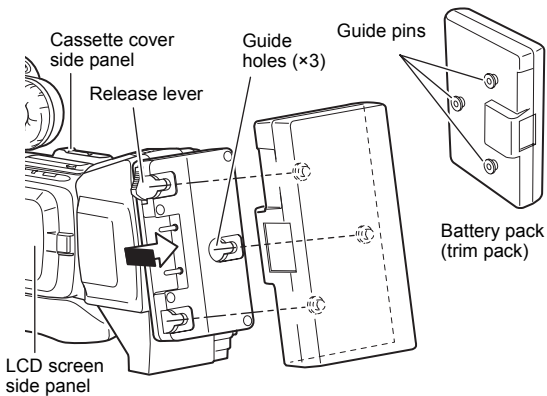

2. Slide the battery towards the Cassette cover side panel until it clicks.
 - The battery is attached.

Removing the Battery

Slide the battery towards you (LCD screen side panel) while holding down the release lever, and pull away from the device to remove the battery.

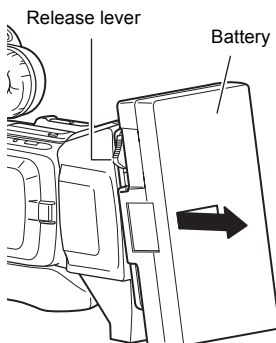

■ GY-HD251E

Use an IDX (Endura) battery.

Attaching the Battery

1. Face the battery terminals down and align the battery V-mount with the battery adapter V-mount attachment.

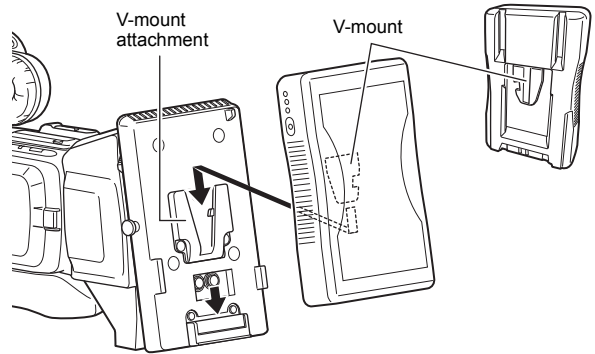

2. Slide the battery down until it clicks and locks.
 - The battery is attached.

Removing the Battery

Slide the battery up while holding down the lock release button to remove the battery.

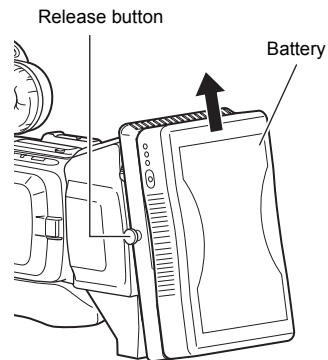

Battery Operation (Cont'd)

Precautions for the Battery Operation

- Do not detach the battery pack while recording is taking place.
- Do not connect or disconnect the DC cable while operating with a battery pack.
The following symptoms may occur if the DC cable is connected or disconnected while operating with a battery pack.
 - The power is cut off for a moment when the DC cable is disconnected.
 - Noise to the video and audio signals occurs. Audio signal are muted.
- When operation is continued with DC input after the battery pack capacity has been used up, set the POWER switch to OFF after the DC power is applied. Then switch ON again.
- If the GY-HD250/GY-HD251 is left with the battery pack attached, a small amount of power is consumed even if the POWER switch on the GY-HD250/GY-HD251 is set to OFF.
Remove the battery pack when the GY-HD250/GY-HD251 is not going to be used.

Remaining Battery Power Display

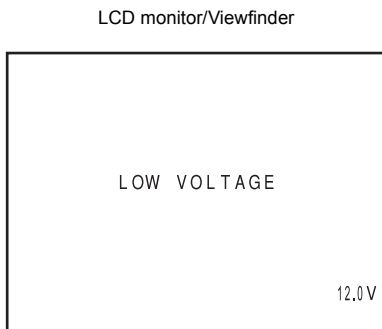

When the remaining battery power is nearly exhausted, the following warnings will be generated.

- Viewfinder screen or LCD monitor
 - When a Status screen is displayed (excluding the STATUS 2, 3 screen in the Camera mode)
 - Alarm indication: LOW VOLTAGE displayed.
- FRONT and BACK TALLY lamp on camera: Blinks
- Monitoring loudspeaker and PHONES jack: Alarm sound

MEMO

- After the remaining battery power warnings appear, the GY-HD250/GY-HD251 automatically stops operation if the battery power operation is continued.

- When you use an Anton Bauer battery, the remaining battery (capacity or time) can be displayed in the STATUS 1 screen of the LCD screen or viewfinder. Set BATTERY INFO. on the LCD/VF[3/4] menu screen to CAPA% or TIME to display the remaining battery. When using the IDX Endura battery, the remaining capacity (%) can be displayed. See page 91.

Operating Time with Battery Pack

When a fully charged battery pack is attached, the approximate continuous operating time is as follows

Battery Pack	Continuous Operating Time (at 25°C (77°F))
Dionic 90 (U model)	Approx. 3.2 hours
Endura-7 (E model)	Approx. 2.5 hours

- Battery operating time may differ depending on the age of the battery pack, charging conditions and the operating environment, etc. Use the values in the table on the above for approximate reference times.
- Operating time is reduced in areas with a cold environment.
- Operating time is reduced when the power zoom lens and LCD are used frequently.

Precautions for the Battery Pack

- When the battery pack is not in use, it must be stored in a cool, dry place.
Do not leave the battery pack in a place where it might be subject to a high temperature (under direct sunlight in a car, etc.), this could cause leakage of the fluid or shorten service life.
- When the terminal section of the battery pack gets dirty, the operating time will be shortened.
- If the operating time becomes greatly reduced even immediately after recharging, the service life of the battery pack is nearly finished.
Purchase a new battery pack.

Recharging

- Recharge the battery pack after completely discharging it. Repeated recharging with residual charge remaining could result in reduced battery capacity.
- If the battery capacity is reduced by repeating incomplete recharging, or recharging without discharging, once discharge the battery pack completely, then recharge it to restore the battery capacity.
- If the battery pack is recharged with its internal temperature raised immediately after use, recharging may not be performed completely.
- Perform charging in an environment where the temperature is between 10°C (50°F) and 35°C (95°F). 20°C (68°F) to 25°C (77°F) is the ideal temperature range for charging. If the environment is too cold, charging may not complete.

Turning the Power ON

Turning the Power ON

1. Set the POWER switch to ON.
This device turns on in Camera mode.
- The operation differs according to whether this device is in the Camera mode or in the VTR mode.
The mode switches each time you press the CAM/VTR button. When the mode is switched, the VTR indicator displays the following statuses.
While the mode is being switched : Flashing
In VTR mode : Lit
In Camera mode : Off

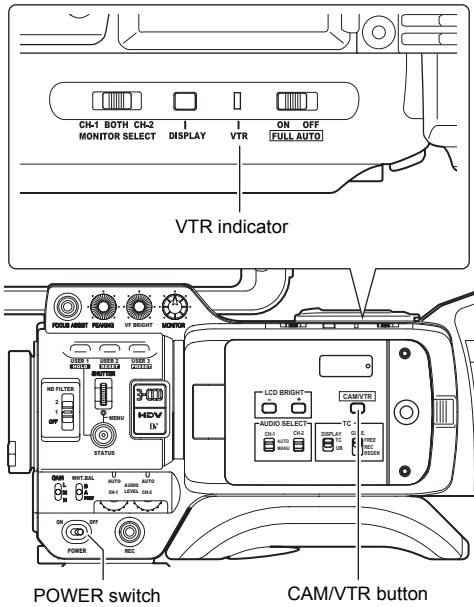

Camera mode

The GY-HD250/GY-HD251 enters the Camera mode. The camera image is displayed in the viewfinder or on the LCD monitor. When a recordable videocassette is loaded, the GY-HD250/GY-HD251 enters the record-standby mode automatically. "STBY" is displayed in the VTR operation mode indication area of the LCD monitor and/or in the viewfinder. In this condition, press the REC/VTR trigger button to start recording.

* Playback is also possible in the Camera mode.
Playback operation becomes possible when the STOP button is pressed to set the VTR operation mode indicator to indicate "STOP".

VTR mode

The GY-HD250/GY-HD251 enters the VTR mode. The camera image will not be displayed in the viewfinder or on the LCD monitor. When a videocassette is loaded, the GY-HD250/GY-HD251 enters the stop mode. "STOP" is displayed in the VTR operation mode indication area of the LCD monitor and/or in the viewfinder.
HDV/DV input is possible through the IEEE1394 connector.

Turning the Power OFF

1. Place the GY-HD250/GY-HD251 in the record-standby or STOP mode.
2. Set the POWER switch to OFF.
3. Remove the battery pack or the power supply to the DC INPUT connector. (When the camera is not going to be used for a longer period.)

CAUTION

- Do not set the POWER switch to OFF while recording is taking place.
Confirm that the "STBY" or "STOP" indication is shown in the VTR operation mode indication area before the power is turned off.
Should the POWER switch accidentally be set to OFF during a recording, wait at least 5 seconds before turning the power on again.
- Always set the POWER switch to OFF before disconnecting the power supply.
Do not remove the battery pack or turn AC adapter OFF while the POWER switch on the camera is still set to ON.

Loading/Unloading the Cassette

Cassette Loading

Use a videocassette tape marked MiniDV.

- To record, slide the switch on the back for use in preventing accidental erasure to the "REC" side.
- Remove any the tape slack before loading.

1. Turn the POWER switch ON.
2. Slide the EJECT switch on the top panel of this device to the side.
The videocassette cover opens automatically and a videocassette tape can be inserted.
3. Insert a videocassette tape into the videocassette holder. With the tape window facing out, move the switch on the back of the videocassette up and firmly push the center back of the videocassette straight in as far as it will go.
4. Carefully push the center ("Push here" sticker) of the videocassette cover in the direction of the arrow as far as it will go to close it.
 - After the cover is closed, it takes about 10 seconds until recording can begin or this device can enter STOP mode.

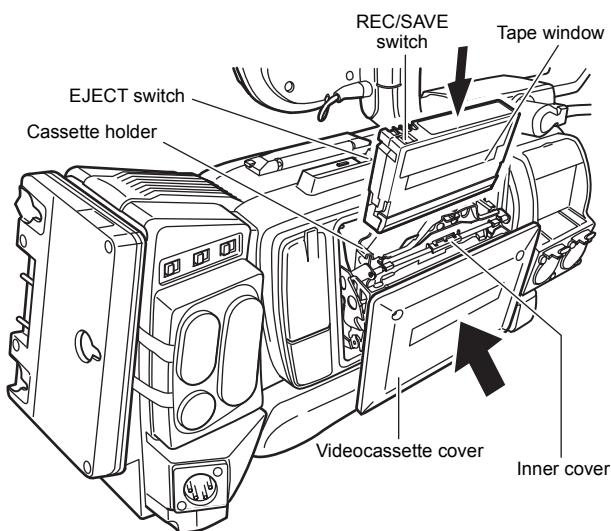

■ If the power is on, the modes are as shown below.

MODE	REC/SAVE switch	
	REC	SAVE
Camera	Record-standby mode	STOP mode REC INHIBIT is displayed on the LCD monitor and in the viewfinder.
VTR	STOP mode	

Unloading the Cassette

1. Turn the POWER switch to ON.
2. When this device is in shooting standby mode or stop mode, slide the EJECT switch to the side and wait until the videocassette cover opens completely.
 - The LED next to the EJECT switch flashes.
A few seconds pass before the videocassette tape is ejected.
3. The LED turns off and the videocassette cover opens.
 - Take out the videocassette tape.
4. Carefully push the center of the videocassette cover in the direction of the arrow as far as it will go to close it.

CAUTION

- When you close the videocassette cover, push it in firmly as far as it will go. If the videocassette cover is not closed properly, it becomes half-locked and this device cannot function.
If this happens, firmly push the videocassette cover in again as far as it will go to lock it.
- The videocassette cover does not open during recording even if you slide the EJECT switch.
- Do not leave the videocassette cover open for a long time.
Dust or dirt may enter the inside and cause damage.
- Do not touch the videocassette cover or interfere with the eject operation while ejecting is in progress. This will cause damage.
- When you close the videocassette cover, do not press the black area of the inner cover.

Setting and Displaying the Date and Time

The date and time of the built-in clock should be set. Powered by the built-in backup battery the set date and time data continue to count even when the power is switched off.

- The set date and time data are displayed on the LCD monitor or in the viewfinder and recorded on the tape in accordance with the settings made on the menu screen.

Setting the Date and Time Style

The date and time are set on the menu screen. When setting while observing on a monitor connected to the connector, set the ANALOG OUT CHAR. item or SDI OUT CHAR. item on the OTHERS[1/2] menu screen to ON.

1. Set the POWER switch to ON.
2. Press the STATUS button for 1 second or longer to display the TOP MENU screen.

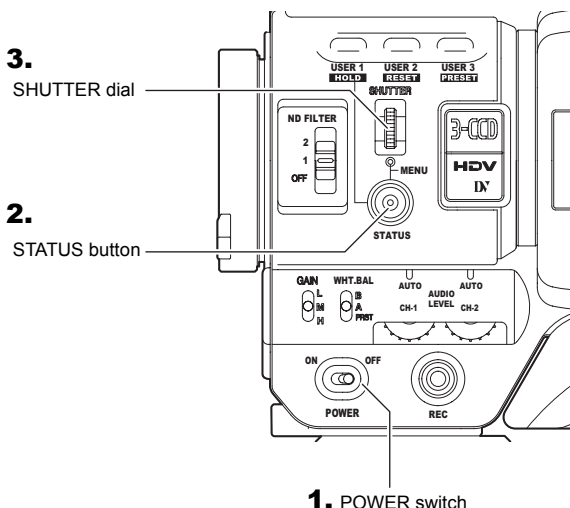

3. Rotate the SHUTTER dial to align the cursor (▶) with the TC/UB/CLOCK item, and then press the SHUTTER dial in the direction of the camera body.
 - The TC/UB/CLOCK menu screen appears.
4. Rotate the SHUTTER dial to align the cursor (▶) with the TIME/DATE item, and then press the SHUTTER dial.
 - The TIME/DATE menu screen appears.
 - Set the DISPLAY item on the TIME/DATE menu screen to ON.

TC/UB/CLOCK menu screen

```

--- TC/UB/CLOCK ---
TCG SOURCE      INTERNAL
TC PRESET       00:00:00:00
                EXECUTE
UB PRESET       00 00 00 00
                EXECUTE
DROP FRAME      DROP
TC DUPLI.       OFF
HEADER REC...
▶TIME/DATE...
PAGE BACK
    
```

5. Make settings on the TIME/DATE menu screen. (This includes display style, etc.)

TIME/DATE menu screen

```

--- TIME/DATE ---
DISPLAY         ON
DISPLAY MODE    BARS+CAM
DISPLAY STYLE   \DATE+TIME/
▶DATE STYLE     -MM/DD/YY-
TIME STYLE      /24HOUR\ \
SEC DISPLAY     ON
TIME SHIFT      OFF
CLOCK ADJUST...
PAGE BACK
    
```

- DATE STYLE : Selects the style for displaying the date.
 YY/MM/DD (Year, month, day)
 MM/DD/YY (Month, day, year)
 DD/MM/YY (Day, month, year)
- TIME STYLE : The time can be set to display as a 12-hour or 24-hour clock system.
- SEC DISPLAY : To select whether or not indication of seconds should be displayed on the screen.
- TIME SHIFT : Adds time to the built-in clock (time compensation) and displays it. The adjusted time is also recorded on the tape.

- 1 Rotate the SHUTTER dial to align the cursor (▶) with the item to be set, and then press the SHUTTER dial.
 - The setting area of the selected item starts blinking.
- 2 Rotate the SHUTTER dial to change the setting, and then press the SHUTTER dial.
 - The setting area stops blinking and the setting is entered.

MEMO

The TIME STYLE, SEC DISPLAY, DATE STYLE and TIME SHIFT items can also be set and changed after the date and time have been set.

Setting and Displaying the Date and Time (Cont'd)

Setting the Date and Time

1. Display the CLOCK ADJUST menu screen.
Select the CLOCK ADJUST item on the TIME/DATE menu screen.

TIME/DATE menu screen

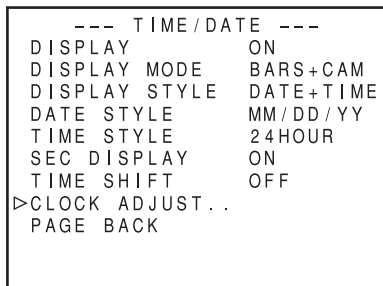

2. Set the date and time.
The blinking digit is the one to be set.

CLOCK ADJUST menu screen

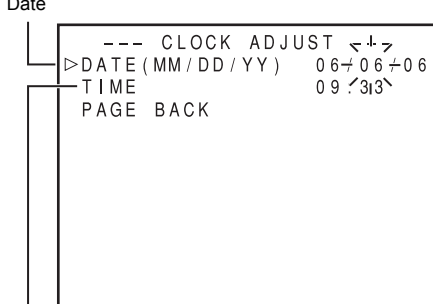

Time (Hour:Min)

1. When the SHUTTER dial is pressed, the blinking digit moves to the next digit.
 2. When the SHUTTER dial is rotated, the value of the blinking digit changes.
When the SHUTTER dial is rotated upward, the value becomes higher. When rotated downward, the value becomes smaller.
 3. Repeat the procedure described in 1 and 2 above to set the day, month, year, hours, minutes.
The digits indicating seconds cannot be set.
 4. Press the SHUTTER dial in sync with a time signal to enter the date and time precisely.
3. When all the settings are completed, rotate the SHUTTER dial to align the cursor with the PAGE BACK item, and then press the SHUTTER dial.
 - The TIME/DATE menu screen returns.
 4. To return to the normal screen, use either of the following methods.
Press the STATUS button
or
Return to the TOP MENU screen and then select the EXIT item on the TOP MENU screen before pressing the SHUTTER dial.

Displaying the Time and Date on the Screen

Whether or not the time and date should be displayed on the screen and how to display them are set on the TIME/DATE menu screen.

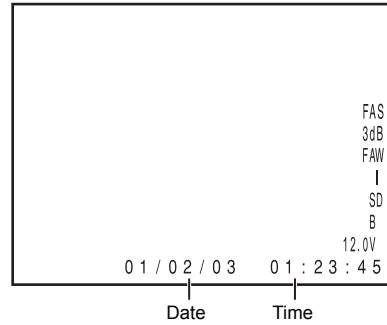

1. Display the TIME/DATE menu screen.
 1. Select the TC/UB/CLOCK item on the TOP MENU screen.
 2. Select the TIME/DATE item on the TC/UB/CLOCK menu screen.
2. Set the TIME/DATE menu screen.
 - DISPLAY item : Sets whether or not date and time should be displayed.
Set to ON to display the indications.
 - DISPLAY MODE : Sets the video output mode in which date and time should be displayed.
 - BARS : Displayed when outputting the color bar.
 - CAM : Displayed when outputting the color camera image.
 - BARS+CAM : Date and time are always displayed.
 - DISPLAY STYLE item : Sets the style in which the date and time are displayed.
 - DATE+TIME : Date and time are displayed.
 - DATE : Date only is displayed.
 - TIME : Time only is displayed.

- Display of date and time in the various operation modes.
 - In Camera mode : The date and time of the internal clock are displayed.
 - In VTR playback mode : The date and time recorded on the tape are displayed.
 - In VTR stop mode : The last read date and time values are displayed.
 - When an HDV/DV signal is input from the IEEE1394 connector : The date and time of the DV input are displayed in DV format. The date and time of the internal clock are displayed in HDV format.

Displaying Time Code

The GY-HD250/GY-HD251 records SMPTE-standard (NTSC) or EBU-standard (PAL) time codes and user's bits. In the play mode or the record mode, the reproduced time codes or user's bits are shown on the LCD monitor or in the viewfinder.

- Time code generator data is output from the [TC OUT] terminal or [HD/SD-SDI] terminal.

The time codes or user's bits can be shown on the LCD monitor or in the viewfinder during playback and recording as follows. (Status screen)

Setting

1. Set the TC/UB item on the LCD/VF[3/4] menu screen to ON.
 - Time codes or user's bit data are displayed on the STATUS screen.

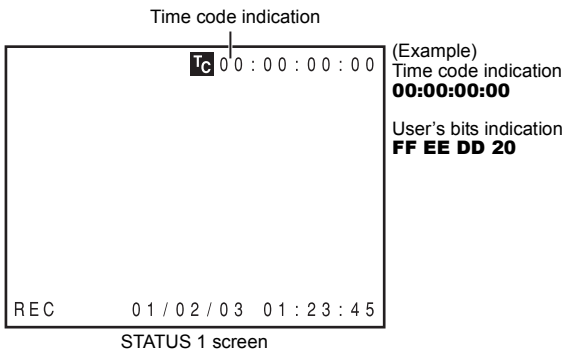

2. Whether time codes or user's bit data should be displayed is selected with the TC DISPLAY switch inside the LCD door.

- TC : Time codes are displayed.
- UB : User's bit data is displayed.

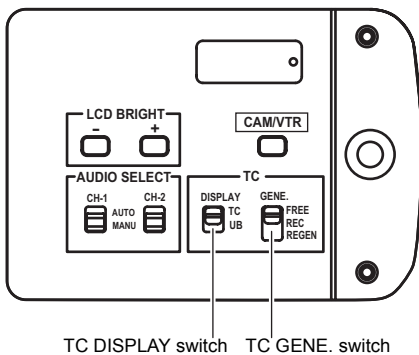

Displayed Time Code/User's Bit

- When TCG SOURCE on the TC/UB/CLOCK menu screen is set to INTERNAL, values from the built-in time code generator is displayed.
- When TCG SOURCE on the TC/UB/CLOCK menu screen is set to EXTERNAL, values from the external time code generator connected to the [TC IN] terminal is displayed.
- When TC DUPLI. on the TC/UB/CLOCK menu screen is set to ON in IEEE1394 input mode, values input in the [IEEE1394] terminal is displayed.
- Values recorded on the tape are displayed for PLAY mode.

Time code input entered the IEEE1394 connector

Pressing the STOP button for 1 second in the EJECT or stop mode displays the DV input time code data or user's bit data from the IEEE1394 connector on the STATUS screen.

DTCG : The time code data from the IEEE1394 connector
 DUBG : The user's bit data from the IEEE1394 connector

To return to display of the original time code or user's bit, press the STOP button. (Display of the normal time code or user's bit is also restored by performing VTR operation.)

MEMO

- To use input time code data from the IEEE1394 terminal, set TCG SOURCE item on the TC/UB/CLOCK menu screen to INTERNAL.
- To record HDV/DV input time code and user's bit from the IEEE1394 connector, set the TC DUPLI. item on the TC/UB/CLOCK menu screen to ON.
 - ☞ See page 93.
- To maintain the continuity of time code data, use with the TC GENE. switch set to REGEN mode when recording HDV/DV input signal from the IEEE1394 connector.
- There is no time code display for HDV input.

CAUTION

A time code with a duration of more than 2 hours may not be displayed correctly by DV components for general consumer use, as some of these lack the capability to display longer time codes.

Presetting and Recording of Time Code

The time codes from the internal time code generator can be recorded at the time of recording scenes.

- The TC/UB/CLOCK menu screen differs depending on whether the FRAME RATE item on the VIDEO FORMAT menu screen is “60/30” or “50/25”.

There are two ways to preset the time code.

- Set from the TC/UB/CLOCK menu screen.
- Set in the LCD screen without opening the menu screen.

This section explains how to set from the TC/UB/CLOCK menu screen.

- * See page 46 for instructions of setting from the LCD screen.

Menu and switch settings to set the time code preset are the same as the settings below.

Setting

To preset the Time Code, make the following settings.

■ TC GENE. switch

Set to REC or FREE.

- REC : The data preset in the time code generator runs only during recording.
 Use this setting if it is necessary to record continual time codes across different scenes.
 * However, approximately ±1-frame variations may occur in scene accuracy.

- FREE : The time code starts to run from the time it is preset in the time code generator.

- Set the TCG SOURCE item in the TC/UB/CLOCK menu screen to INTERNAL.

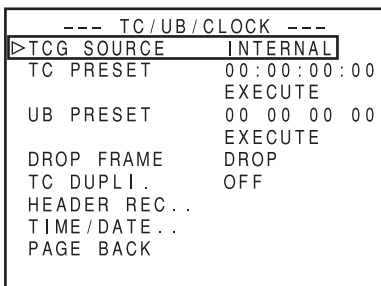

■ TC/UB/CLOCK menu screen (FRAME RATE: 60/30)

Use the DROP FRAME item to select the framing mode for the time code generator.

- DROP : The time code generator’s running method is set the drop frame mode.
 Use this setting when placing emphasis on the recording time.
- NON DROP : The time code generator’s running method is set to the non drop frame mode.
 Use this setting when placing emphasis on the number of frames.

TC/UB/CLOCK menu screen (FRAME RATE: 60/30)

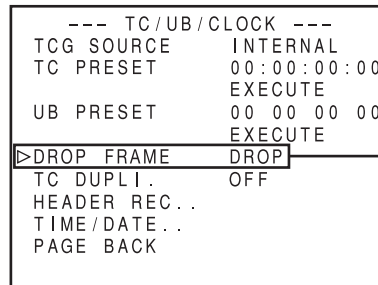

Framing mode:
 Drop frame/
 Non-drop setting

MEMO

Drop frame/Non-drop frame mode

In the NTSC system, the actual number of frames per 1 second is approximately 29.97 frames, but per time code 30 frames are processed. To compensate for this difference, the mode called “drop mode” drops frame 00 and 01 for every minute not divisible by 10. The “non-drop frame mode” is when no frames are dropped and the actual time shift neglected.

■ TC/UB/CLOCK menu screen (FRAME RATE: 50/25)

Whether or not user’s bit data should be recorded can be selected with the UB REC item on the TC/UB/CLOCK menu screen.

TC/UB/CLOCK menu screen (FRAME RATE: 50/25)

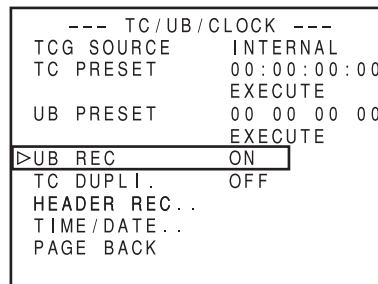

Presetting time code data

The time code and user's bit data are preset on the TC/UB/CLOCK menu screen.

1. Display the TC/UB/CLOCK menu screen.
Select the TC/UB/CLOCK item on the TOP MENU screen.

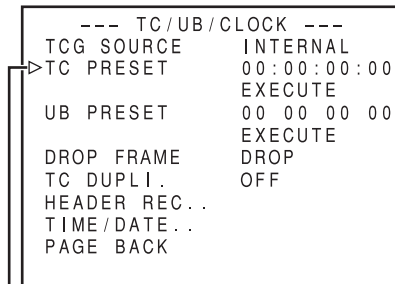

Time code (hour, min, sec, frame)

2. Set the time code (hours, minutes, seconds, frames).
 - 1 Rotate the SHUTTER dial to align the cursor (▶) with TC PRESET, and then press the SHUTTER dial.
 - The first digit of the time code blinks.
The blinking digit is the one to be set.
 - 2 When the SHUTTER dial is pressed, the blinking digit changes.
 - 3 When the SHUTTER dial is rotated, the value of the blinking digit changes.
When the SHUTTER dial is rotated upward, the value becomes higher. When rotated downward, the value becomes smaller.
 - 4 Repeat the procedure described in 2 and 3 above to set the desired value for all digits.
 - 5 After setting the frame digit, press the SHUTTER dial to make EXECUTE blink. The setting values are confirmed when the SHUTTER dial is pressed again.
To cancel the setting, select CANCEL and press the SHUTTER dial.
3. When all the digits are set
 - Press the STATUS button to return to the normal screen
or
 - Rotate the SHUTTER dial to align the cursor (▶) with the PAGE BACK item, and then press the SHUTTER dial to return to the TOP MENU screen.

Presetting user's bit data

The user's bit data are preset with the UB PRESET item on the TC/UB/CLOCK menu screen.

The method for setting is the same as the method for setting the time code described on the left.

- The user's bit can be specified using numerals or alphabetic letters from 0 to F for each digit.
- To record user's bit data, set the UB REC item to ON (Only when set to FRAME RATE 50/25).

CAUTION

It is not possible to set all the digits of the user's bit data to "F".

Reading of the data during playback will not be possible for an all-F setting.

Zero-resetting the Time Code or User's Bit Data

This is performed with the TC or UB PRESET item on the TC/UB/CLOCK menu screen. (Performed separately for the time code and the user's bit data.)

- 1 Rotate the SHUTTER dial to align the cursor (▶) with the TC or UB PRESET item, and then press the SHUTTER dial.
- 2 Rotate the SHUTTER dial to select ZERO PRESET as the setting value, and then press the SHUTTER dial.

MEMO

When a menu screen is not being displayed, you can zero reset the time code data by simultaneously holding down the USER2 button and the STOP button for about 1 second.

Presetting the Time Code from the LCD Screen

The time code can be preset directly from the LCD screen without opening the TC/UB/CLOCK menu screen.

CAUTION

PRESET mode is not available in the following.

- TCG SOURCE item in the TC/UB/CLOCK menu screen is set to EXTERNAL.
- TC GENE. switch is set to REGEN.
- TC DUPLI. item in the TC/UB/CLOCK menu screen is set to ON.
- Menu screen is displayed.
- RECORDING mode is active.
- Switching to CAM/VTR mode (When VTR indicator is blinking).

Setting

- TC/UB/CLOCK menu screen
 - Set TCG SOURCE to INTERNAL.
 - Set framing of the time code generator in DROP FRAME. (When set to FRAME RATE 60/30)
 - Set to enable/disable user's bit recording in UB REC. (When set to FRAME RATE 50/25)
- Set the TC GENE switch to REC or FREE.

MEMO

See page 44 for details on the above settings.

- Set the TC DISPLAY switch. Set to TC to preset time code and UB to preset user's bit.

Operation

This section describes presetting of the time code.

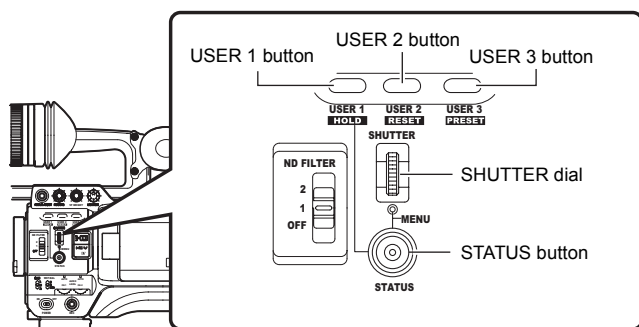

1. In Standby or Stop mode, press the USER1 button for about 2 seconds while holding down the STATUS button.
 - The current time code generator data is displayed in enlarged display mode on the LCD screen. The hour digit starts blinking.

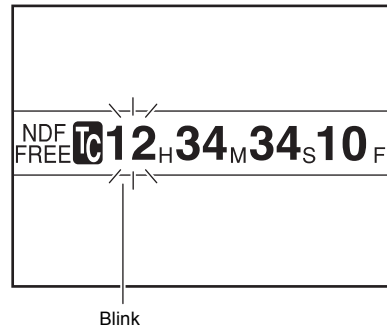

2. Press the USER2 button to reset all data.
 - Data becomes "00:00:00:00" and the hour digit starts blinking.
3. Set the time code (hour, minute, second and frame). The blinking digit can be set.
 - 1 Turn the SHUTTER dial to change the value of the blinking digit. Turn the SHUTTER dial up to increase the value and down to decrease the value.
 - 2 Press the SHUTTER dial to change the blinking digit.
 - 3 Repeat steps 1 and 2 and continue setting for each row.
4. Press the USER3 button to confirm the setting data.
 - The LCD screen returns to the original screen.

Presetting User's Bit

You can specify the user's bit with a number or character between 0 - F.

CAUTION

All digits of user's bit cannot be set to F. If all digits are set to F and read, user's bit is deemed as undefined during playback.

Aborting Preset Operation

While presetting, press the USER1 button while holding down the STATUS button.

- Preset operation stops and the LCD screen returns to the original screen.

CAUTION

- Preset operation is terminated in the following.
 - TC DISPLAY switch is changed
 - CAM/VTR mode switch is changed
 - VTR operations are performed
- USER1, USER2, and USER3 presetting in the SWITCH MODE menu screen is not available when the Time Code Preset screen is displayed.
- The time code preset screen is displayed on the LCD screen or viewfinder. It will not be output from the VIDEO OUT terminal.

Recording Time Codes in Continuation of Time Codes Recorded on Tape

The GY-HD250/GY-HD251 also incorporates a time code reader. Therefore, when this device enters record mode from record-standby mode, it can read the time code data recorded on the tape and record time codes in continuation of the existing data.

The recorded user's bit data are identical to the user's bit data recorded on tape.

* However, approximately ± 1 -frame variations may occur in scene accuracy.

To enable this function, set the time code related switches as follows before starting recording.

Setting

- Set TCG SOURCE on the TC/UB/CLOCK menu screen to INTERNAL.
- Set the TC GENE. switch inside the LCD door to REGEN.
- Set TC DUPLI. item on the TC/UB/CLOCK menu screen to OFF.

MEMO

The time code framing mode automatically becomes the mode (drop frame or non drop frame) already recorded on the tape.

Playing Back Time Code

This device features a time code reader. During playback, the time code or user's bit data recorded on the tape is displayed on the LCD screen or viewfinder status screen.

- When the [PB/PR/TC] switch is set to TC, the playback time code is output from the [PB/TC OUT] terminal (Only in VTR mode).
- When HD/SD-SDI OUT of the VIDEO FORMAT[2/2] menu screen is set to ON, the playback time code is output from the [HD/SD-SDI] terminal.

MEMO

- During playback, if a portion of tape without recording time code runs through, the time code stops running. Playback continues.
- When a tape with a time code that is longer than two hours is played on home-use DV equipment, time code may not be played properly on some models.

About Time Code Mode

■ Camera mode

TC/UB/CLOCK menu	TC GENE. switch		
TCG SOURCE item	FREE	REC	REGEN
INTERNAL	TC PRESET mode	TC REGENE mode	
EXTERNAL	EXT TC mode		

■ VTR mode/IEEE1394 input mode

TC/UB/CLOCK menu		TC GENE. switch		
TCG SOURCE item	TC DUPLI. item	FREE	REC	REGEN
INTERNAL	OFF	IEEE1394 TC SLAVE mode*	TC PRESET mode	TC REGENE mode
	ON		IEEE1394 TC DUPLI. mode	
EXTERNAL	OFF	EXT TC mode		
	ON			

* IEEE1394 TC SLAVE mode is performed with special operations. See page 48.

Synchronizing with the Time Code of the IEEE1394 (DV)-Connected Master Unit

You can synchronize the time code when performing multi-camera recording. The internal time code generator will be synchronized with the time code in the signal input from the IEEE1394 terminal. After synchronization (slave lock), the internal time code generator continues to run even if the IEEE1394 cable is disconnected.

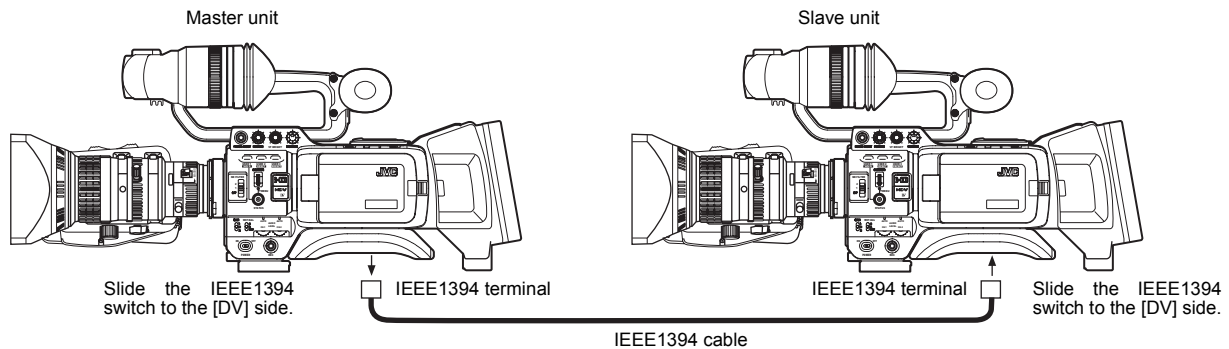

You can use the GY-HD250U, GY-HD251E, GY-HD110U, or GY-HD111E as a slave unit.

Connections

Connect the master unit and the slave unit with an IEEE1394 cable.

Settings and Operations

- **Master unit (GY-HD100U/GY-HD100E/GY-HD101E/GY-HD110U/GY-HD110E/GY-HD111E/GY-HD250U/GY-HD251E)**

1. Set the IEEE1394 switch on the left side to [DV].
2. Set to Camera mode.
3. Set the recording format to DV-60i or DV50i.
4. Set the TC GENE. switch to [FREE].

- **Slave unit (GY-HD250U/GY-HD251E/GY-HD110U/GY-HD111E)**

1. Set the IEEE1394 switch on the left side to [DV].
2. Set to VTR mode.
3. Check that the camera image from the master unit is input.
4. Set TCG SOURCE in the TC/UB/CLOCK menu screen to INTERNAL. (GY-HD250U, GY-HD251E)
5. Set the TC GENE. switch to [FREE] and the TC DISPLAY switch to [TC].
6. Set to STOP mode or EJECT mode.
7. Press the STOP button for 1 second.
 - The DV input time code data from the IEEE1394 terminal is displayed in the status display. (When status is in magnified size, characters are displayed.)
8. Press the USER1 button to begin slave lock. (To skip slave lock, press the USER3 button and clear the status display.)

Status display

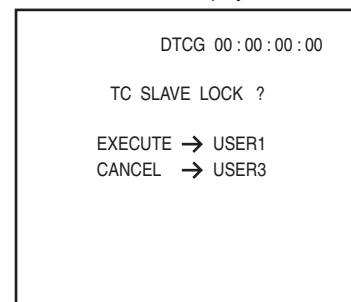

9. Check that the time code that is synchronized with the master unit is running.
10. Disconnect the IEEE1394 cable.
11. The slave unit finally returns to Camera mode.

MEMO

- Slave lock cannot be performed in the following instances.
 - Slave unit is in CAMERA mode
 - Slave unit is in VTR mode and there is no DV signal
 - The TC GENE. switch on the slave unit is not set to FREE
 - HDV format
- If slave lock is performed in DV format and is then switched to HDV format, frame digit may deviate.
- If power is turned off, slave lock is disabled. Perform slave lock operation again.
- Slave lock cannot be performed for UB (User's bit).
- If the frame rate for the master unit and slave unit is not synchronized, it will not run properly. Synchronize frame rate before using.
- If DROP/NON DROP is not synchronized, it will not run properly. Synchronize DROP/NON DROP before using.

Synchronizing with an External Time Code Generator

Synchronize the built-in time code generator with the SMPTE/EBU-compliant LTC time code, which is input from the [TC IN] terminal. After synchronization (slave lock), the built-in time code generator continues to run even if external time code are not input.

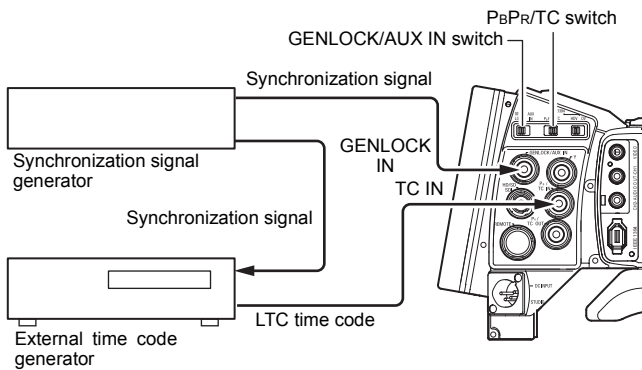

Connection

- Input external synchronization signal to the external time code generator and the GENLOCK/AUX IN terminal of this device.
Use BB signals or Tri-sync HD signals as the external synchronization signals.

CAUTION

When the power switch is turned on while the external synchronization signal is input, a vertical vibration occurs for a few seconds. This is not a malfunction.

- Input SMPTE/EBU-compliant LTC time code signal to the Pb/TC IN terminal.

Setting

- Set the [GENLOCK/AUX IN] switch to GENLOCK.
- Set the [PbPr/TC] switch to TC.
- Set TCG SOURCE in the TC/UB/CLOCK menu screen to EXTERNAL.
- Set the LCD screen or viewfinder to STATUS 1 screen display.
Or set the LCD screen to enlarged status display screen.
See page 29.

Operation

- Set the external time code generator and operate it.
 - The built-in time code generator synchronizes with the input external time code data.
"L" lights up in the STATUS 1 screen of LCD screen or viewfinder. "L" also lights up when the LCD screen is in enlarged character display.

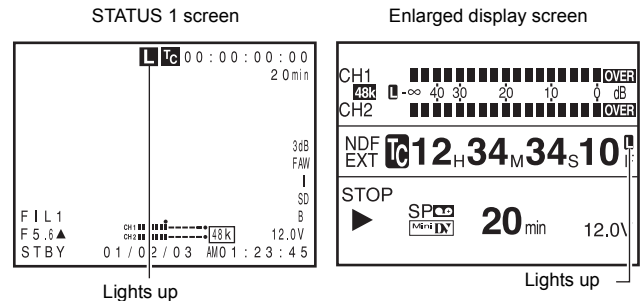

- "L" blinks when the time code cannot be synchronized.
- The built-in time code generator continues to run even if the external time code generator is disconnected after synchronization.

CAUTION

- If a time code generator is connected or disconnected during recording, servo lock will be disturbed.
- The user's bit data range for an input external time code generator is 00 00 00 00 to FF FF FF FE.
When FF FF FF FF is entered, FF FF FF FE is recorded.

- When connecting multiple devices and assigning one as the master unit and others as slave units**
If there is only one slave unit, connect as shown below.
If there are multiple slave units, input external synchronization signals to all GENLOCK/AUX IN terminals from the synchronization signal generator.

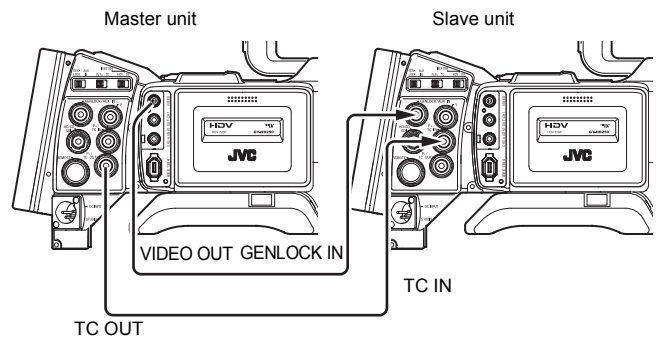

Screen Adjustment

LCD monitor direction, angle, screen brightness, etc. can be adjusted.

Adjusting the Direction and Angle of the LCD monitor

- With the LCD door in the open condition, rotate the LCD door.
- It can be turned 180° in upward direction and 90° in downward direction.
When turned 180° upward direction, the LCD monitor can be viewed from the lens side (vertically inverted image).

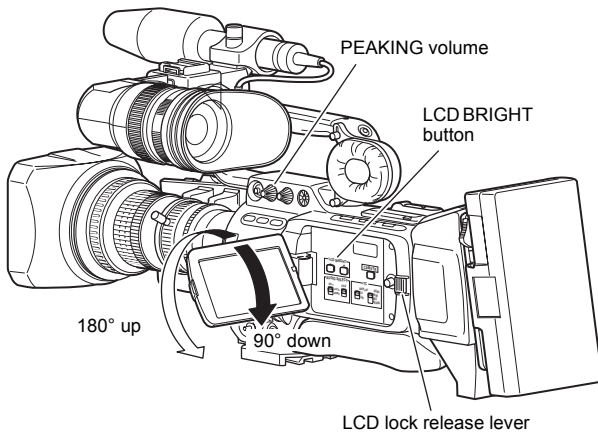

Adjusting the LCD monitor

- PEAKING:
Adjusts the contour of the LCD monitor.
- LCD BRIGHT:
Adjusts the brightness of the LCD monitor.

Adjustments are made on the LCD/VF[2/4] menu screen.

☞ See page 90.

- LCD MIRROR MODE:
Sets the LCD monitor to display mirrored images when shooting facing the subject.

Adjustments are made on the LCD/VF[4/4] menu screen.

☞ See page 92.

- LCD CONTRAST:
Adjusts the contrast of the LCD monitor.
- BLACK & WHITE:
Sets the LCD monitor and viewfinder to black and white display.

Viewfinder Adjustment

Direction of the Viewfinder

Adjust the position and angle of the viewfinder.

Diopter Adjustment

Rotate the eyepiece focusing ring until the viewfinder screen image is clearly visible.

Adjustment of the Viewfinder Screen

- PEAKING:
Adjusts the contour of the LCD monitor and the viewfinder screen.
- VF BRIGHT:
Adjusts the brightness of the viewfinder screen.

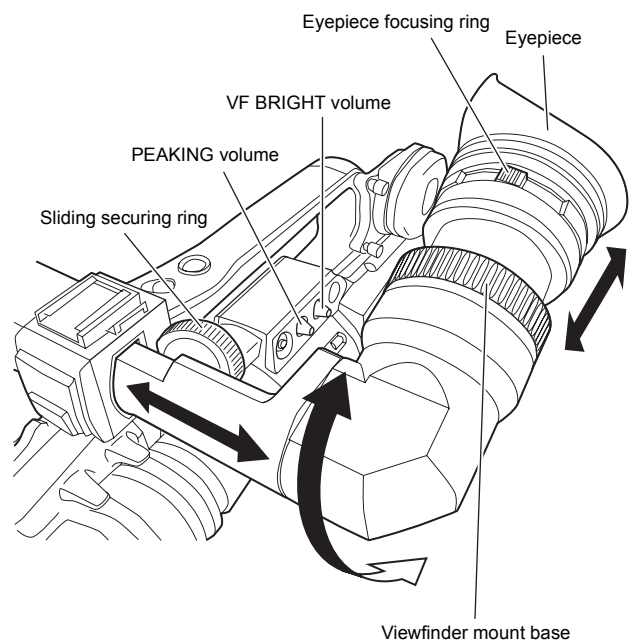

Adjustments are made on the LCD/VF[4/4] menu screen.

☞ See page 92.

- VF CONTRAST:
Adjusts the contrast of the viewfinder screen.
- BLACK & WHITE:
Sets the LCD monitor and viewfinder to black and white display.

MEMO

The screen size of the viewfinder can be changed by selecting the desired size with the ASPECT item on the VIDEO FORMAT[1/2] menu screen (4:3 or 16:9).

Back Focus Adjustment

It is only necessary to perform this when the lens is attached for the first time or when focusing is not correct in both the telephoto and wide-angle positions.

- It is easier to adjust back focus when the subject is more than 3 meters from the camera. The optimal subject for this adjustment is a Siemens star chart.

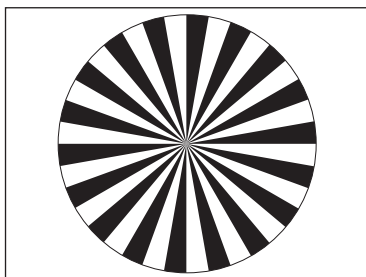
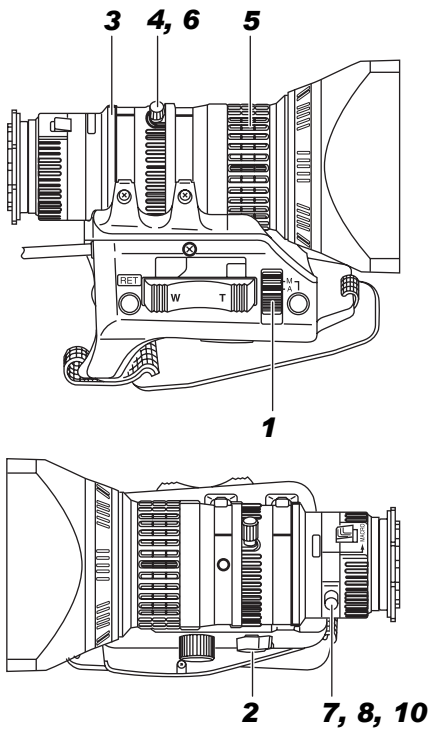

Siemens star chart

- 1.** Set the IRIS mode switch to M (Manual).
- 2.** Set the zoom mode to M (Manual).
- 3.** Open the iris by turning the iris ring.
If the illumination is too strong, reduce it or move to a darker place.
- 4.** Turn the zoom lever until the lens is at the maximum telephoto position.
- 5.** Bring the subject into focus.
- 6.** Set the lens to maximum wide-angle.
- 7.** Loosen the back focus ring retaining knob.
- 8.** View the same subject and adjust the back focus ring for the best possible focus.
- 9.** Repeat steps **4.** through **8.** about three times for fine adjustment until the subject remains in focus in both the telephoto position and the wide-angle position.
- 10.** Tighten the back focus ring retaining knob to secure the ring.

White Balance Adjustment

Since the color of light (color temperature) varies depending on the light source, it is necessary to re-adjust the white balance when the main light source illuminating the subject changes.

White Balance Adjustment

Two kinds of white balance adjustment results can be stored in memories AUTO A and AUTO B.

Adjustment procedure

1. Set the following switches.
 - Set the POWER switch to ON.
 - Set the IRIS mode switch of the lens to A (Auto).
 - Set the FULL AUTO switch to OFF.
2. Set the ND filter switch according to the current lighting.
3. Set the WHT.BAL switch to A or B.
4. Place a white object near the center of the screen under the same lighting conditions as the target subject and zoom in to fill the screen with white.
5. Press the AWB (Auto White Balance) button.

“AUTO WHITE A, B OPERATION” is displayed in the viewfinder while the auto white balance adjustment circuit operates. When correct white balance is obtained, the approximate color temperature is displayed together with “AUTO WHITE A, B OK” for about 5 seconds.

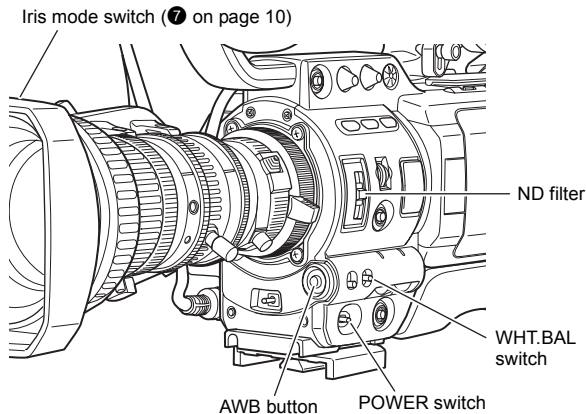

MEMO

Fine-tune red and blue to match the white adjusted in white balance in WHITE PAINT<R>/ on the WHITE BALANCE menu screen. See page 85.

Error messages

If the adjustment ends abnormally, an error message, as described below, blinks for about 5 seconds.

- NG: OBJECT (Improper object)

Displayed when there is not enough white color on an object or the color temperature is not suitable.

Replace the color temperature conversion filter or use another white object and re-adjust the white balance.

- ERROR: LOW LIGHT (Insufficient illumination)

Displayed when the illumination is dim. Increase the illumination and then re-adjust the white balance.
- ERROR: OVER LIGHT (Excessive illumination)

Displayed when the light is excessively bright. Decrease the illumination and then re-adjust the white balance.

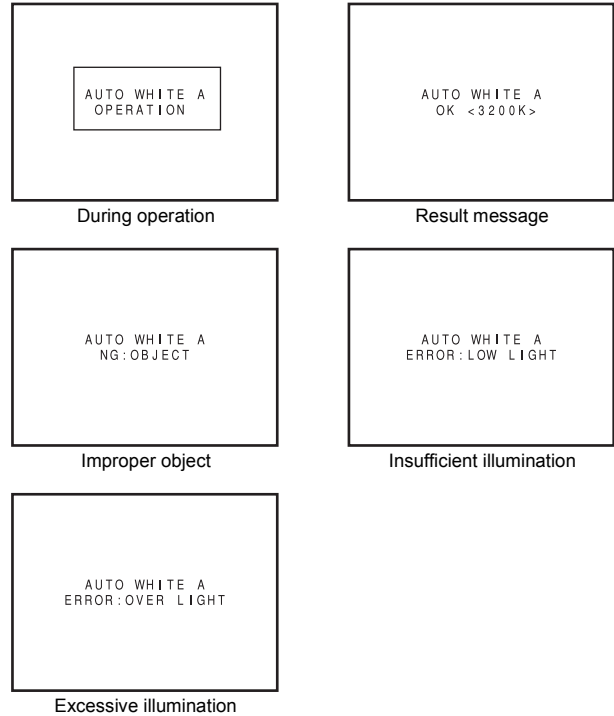

CAUTION

- Do not adjust using any highly reflective objects, such as metal, etc., as this may result in improper white balance adjustment.
- The FAW (Full Auto White balance) function cannot provide optimum white balance with a subject outside the FAW adjustment range, for example when it contains only a single color or not enough white color.
- The accuracy of the FAW (Full Auto White balance) is inferior to that of the Auto white balance.
- When the power is turned on with the FAW mode selected, it takes about 10 seconds for the FAW adjustment to be completed. Do not shoot within this interval.

Full Auto White Balance (FAW)

The FAW function adjusts the white balance value automatically as the lighting condition changes.

This mode is convenient when you have no time to adjust the white balance or when the camera is moved frequently in and out of places under different lighting conditions.

Setting procedure

The FAW function can be activated with the FAW item on the SWITCH MODE menu screen. The FAW function can be allocated to one of the white balance switching switches A, B, or PRESET.

See page 86.

White Shading Adjustment

It is necessary to perform this adjustment to the camera when attaching a lens that is different from the previously attached lens.

Even if white balance is achieved in the middle of the screen, it may not be achieved at the top and bottom of the screen. Greens and magentas may be colored. This is due to characteristics of the lens. Correcting this phenomenon is called White Shading Adjustment.

Perform this after adjusting white balance.

White shading adjustment is performed on the WHITE BALANCE menu screen.

Adjustment procedure

1. White balance the camera.
 2. Set the camera's lens controls as follows:
 - a. Set the IRIS opening to F4 or higher number.
 - b. In the case of a zoom lens set the ZOOM at the center of its range.
 3. Shoot a uniformly lit white sheet of paper and fill the monitor screen with it.
 4. Set the monitor CHROMA level to maximum.
 5. Check the color of the monitor screen. If the top and the bottom of the monitor screen are white then no adjustment is necessary. If the top of the monitor screen is greenish and the bottom is reddish or if the top is reddish and the bottom is greenish then continue with this adjustment.
 6. Adjust the LEVEL G in the SHADING menu item to minimize the color difference between the top and bottom of the screen.
 7. It is recommended that only LEVEL G be adjusted.
- ① Display the WHITE BALANCE menu screen.
Follow the steps in "Setting Menu Screens" on page 75 and proceed as follows.
MENU→CAMERA PROCESS[1/2]→CAMERA PROCESS[2/2]→ADVANCE PROCESS→WHITE BALANCE

```
--- WHITE BALANCE ---  
WHITE PAINT<R>  NORMAL  
WHITE PAINT<B>  NORMAL  
>SHADING        PRESET  
LEVEL R         - - - -  
LEVEL G         - - - -  
LEVEL B         - - - -  
PAGE BACK
```

Setting in the WHITE BALANCE screen is performed as follows.

■ Selecting an item

Turn the SHUTTER dial to align the cursor (▶) with the desired item, and press the SHUTTER dial.

- The item is selected and the setting value blinks.

■ Changing the setting value

Turn the SHUTTER dial to change the blinking value. When the SHUTTER dial is pressed, the value stops blinking and the setting is changed.

- 2 Perform the above steps to set SHADING to MANUAL.
 - 3 Select LEVEL R, LEVEL G, LEVEL B and press the SHUTTER dial.
 - The setting value for the selected LEVEL blinks and becomes available for changing.
 - 4 Change the setting values for LEVEL R, LEVEL G, and LEVEL B with the SHUTTER dial while referring to the monitor.
When setting values are increased, colors at the bottom of the screen are suppressed and the top is enhanced.
LEVEL R: Adjusts reds.
LEVEL G: Adjusts greens.
LEVEL B: Adjusts blues.
<Range: -128 to +127>
 - 5 Press the SHUTTER dial after changing the setting values to save in the memory.
 - 6 Press the STATUS button to return to the normal screen.
8. When white shading adjustment is completed, adjust white balance again.
☞ See "White Balance Adjustment" on page 52.

CAUTION

- If the lens setup is incorrect, the white shading adjustment might result in over compensation. When performing this adjustment, set the lens to the recommended settings. Do not open the lens IRIS beyond F4; do not set a telephoto lens to its extreme wide position or telephoto position.
- White shading occurs due to the optical characteristics of the mounted lens, it is not a camera malfunction.

Setting the Video Format

Set the video format using the FRAME RATE item and the REC item on the VIDEO FORMAT menu screen.

Setting the FRAME RATE Item

1. Press the STATUS button for at least 1 second.
 - The TOP MENU screen is displayed.

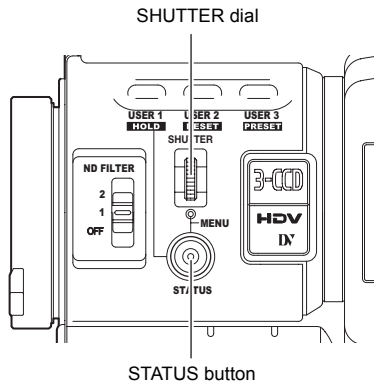

2. Turn the SHUTTER dial and bring the cursor (▶) to the VIDEO FORMAT.. item and press the SHUTTER dial.
 - The VIDEO FORMAT[1/2] menu screen is displayed.

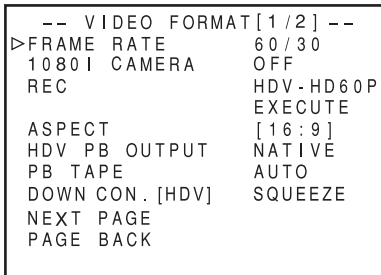

3. Turn the SHUTTER dial and bring the cursor (▶) to the FRAME RATE item and press the SHUTTER dial.
 - The setting for the selected item flashes and can be changed.
 - “CHANGE THE SYSTEM” is displayed on the screen.

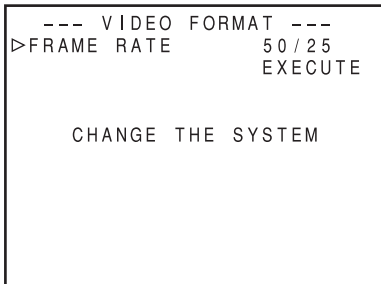

4. Turn the SHUTTER dial, change the setting and push the SHUTTER dial.
 - The setting stops flashing and is temporarily set.
 - Move the cursor (▶) to the EXECUTE item and EXECUTE flashes.
5. Push the SHUTTER dial.
 - “REBOOT! SYSTEM CHANGE” is displayed on the screen and after a few seconds the system is rebooted.

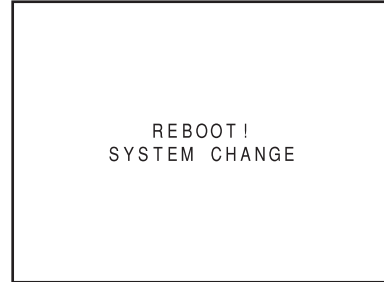

Setting the REC Item

Set the REC item using the same steps as for the FRAME RATE item.

MEMO

- If you change the FRAME RATE item setting, the system is rebooted.
- The synchronous video signal is momentarily disturbed when the REC item setting is switched.
- We recommend the following settings for REC item (in HDV format).
 - When recording images with a lot of motion:
Set to HDV60p or HDV50p
 - When recording images with little motion:
Set to HDV30p or HDV25p

Camera Settings

1. Set the switch positions.
 - A. [GAIN] switch: Set to L (0 dB).
 - B. [WHT. BAL] (Auto White Balance) switch: Set to A or B.
2. Set the lens' iris mode switch to "A" (Auto iris side).
3. Select the ND filter.

ND FILTER		Suitable Location
OFF	OFF	Indoors, dark outdoors
1	1/4ND	Outdoors under clear sky
2	1/16ND	Outdoors under extremely clear sky

4. Set the shutter speed to OFF with the SHUTTER dial.

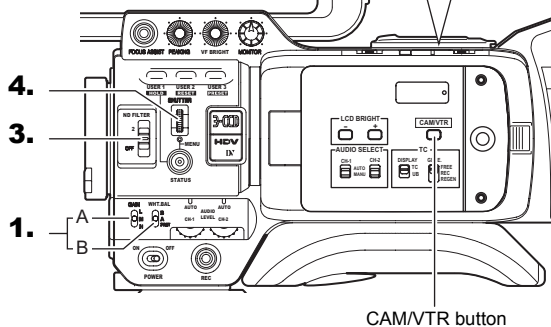
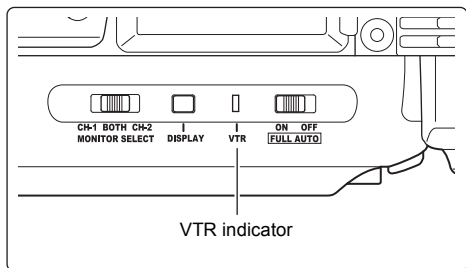

Screen Size (4:3/16:9) Mode Selection

The screen size of recorded images can be selected with the ASPECT item on the VIDEO FORMAT[1/2] menu screen. See page 78.

- To record using the standard screen, set ASPECT to 4:3.
- To record using the 16:9 screen, set ASPECT to 16:9.

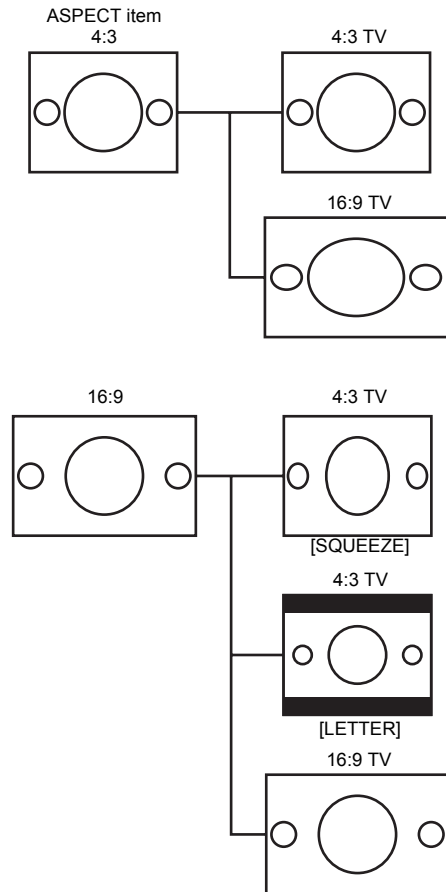

- In DV mode, selection of SQUEEZE and LETTER is not possible. The screen display mode becomes SQUEEZE.

MEMO

- When you set the REC item on the VIDEO FORMAT[1/2] menu to HDV format, the ASPECT item is fixed at 16:9 and "[16:9]" is displayed.
- If the above applies, you can set to display the image in the style of 4:3 televisions.
 - ☞ See "DOWN CON. [HDV]" on page 78.
- In the SAFETY ZONE item on the LCD/VF[1/4] menu screen, you can display the safety zone for a standard screen as well as a 16:9 screen in the viewfinder or LCD monitor.
 - ☞ See page 89.
- When the ASPECT item is set to 4:3, the screen that is displayed may differ depending on the 16:9 television you are using.

Audio Input Signal Selection

The GY-HD250/GY-HD251 is provided with the INPUT1 connector and the INPUT2 connector for audio input. Select the audio from the INPUT1 connector or the INPUT2 connector using the CH-2 INPUT switch for the audio to be recorded in CH-2.

Selecting the CH-2 channel input connector

Select using the CH-2 INPUT switch.

- INPUT1 : Inputs the audio from the INPUT1 connector into CH-2.
- INPUT2 : Inputs the audio from the INPUT2 connector into CH-2.

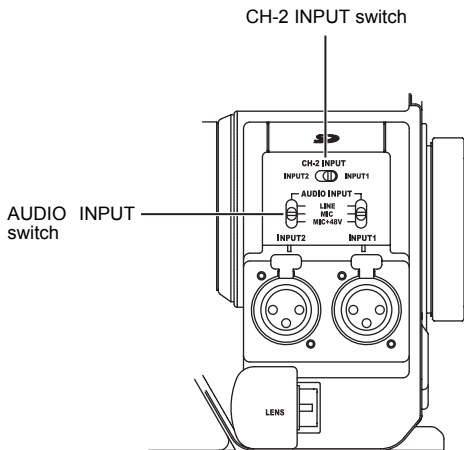

MEMO

The audio from the INPUT1 connector is also input into CH-1 regardless of the setting.

Selecting the audio signal input

Select the sound to be input to the INPUT1 or INPUT2 connector using the AUDIO INPUT switch.

The setting is made for each of INPUT1 or INPUT2 connector.

- LINE : Set to this position when connected to audio equipment, etc. The reference input level is +4 dBs.
- MIC : Set to this position when using a dynamic microphone.
- MIC+48V : Set to this position when a microphone (phantom microphone) requiring +48 V DC power supply is connected.

CAUTION

When connecting a component that does not require +48 V power supply, make sure that the switch is not set to MIC+48V before the component is connected.

MEMO

You can select the normal input level for MIC and MIC+48V in the INPUT1, 2 MIC REF. item on the AUDIO/MIC[1/2] menu screen.

Adjusting Audio during Recording

For each audio channel, use the CH-1/CH-2 AUDIO SELECT switch to select whether the audio level adjustment should be set to AUTO mode or MANUAL mode.

■ Adjusting the audio input level control

The audio input level can be adjusted manually when the GY-HD250/GY-HD251 is in the record, record-standby or stop mode.

1. Set the CH-1/CH-2 AUDIO SELECT switch of the channel whose audio level that you want to adjust manually to MANU.

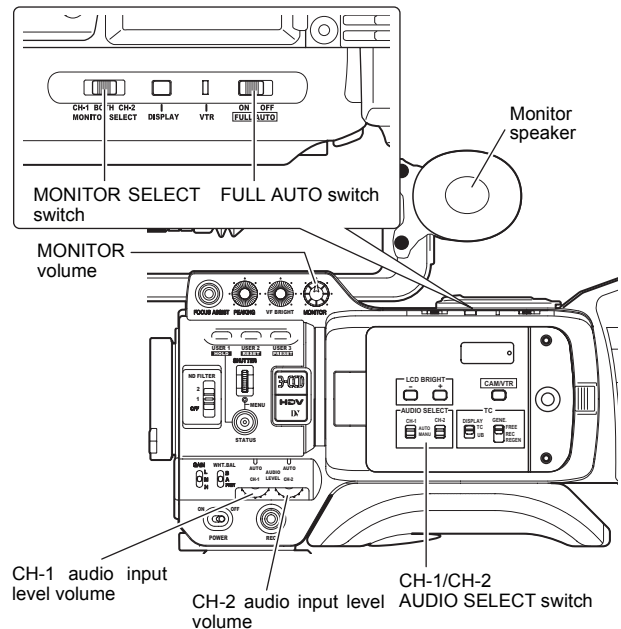

2. Rotate the audio input level control corresponding to the audio input level to be adjusted.

- Adjust so that the peak level does not exceed the -3 dB point when a loud sound is input.

STATUS 1 screen

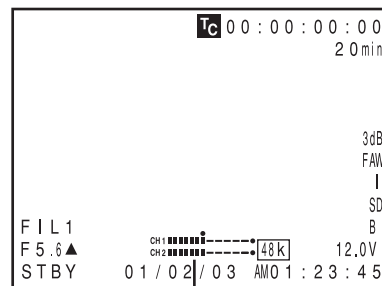

Audio level

Indicator level (reference)

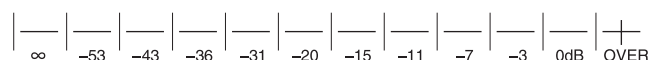

MEMO

- When AUDIO LIMITER in the AUDIO/MIC[1/2] menu screen is set to ON, the AUDIO LIMITER functions in manual adjust mode. Recording level is suppressed when excessive audio is input.
☞ See "AUDIO LIMITER" on page 87.
- The reference level for audio recorded on the tape can be set with the AUDIO REF. LEVEL item on the AUDIO/MIC menu screen. (-20 dB or -12 dB) The level will change for both CH-1 and CH-2.

CAUTION

- When the AUDIO INPUT switch is set to MIC, be sure to check that the microphone is connected to the INPUT1/2 connector. If the microphone is not connected, increasing the audio level could cause noise from the input connector to be recorded on the tape. When the microphone is not connected to the INPUT1/2 connector, set the AUDIO INPUT switch to "LINE" or turn down the audio level control.
- In the FULL AUTO mode, the audio level volume cannot be adjusted with the audio level controls on the CH-1 and CH-2.

MEMO

- When connecting a stereotype earphone, make the following settings to output stereo sound.
 - ① Set the MONITOR SELECT switch to BOTH.
 - ② Set the AUDIO MONITOR item on the AUDIO/MIC[2/2] menu screen to STEREO.
- When AUDIO MONITOR item on the AUDIO/MIC[2/2] menu screen is set to "STEREO", only the audio of CH-1 is output from the monitoring speaker.
- The volume of the alarm tone is set with the ALARM VR LEVEL item on the OTHERS[1/2] menu screen. (OFF/LOW/MIDDLE/HIGH)

Monitoring Audio during Recording

The audio input during recording, in record-pause or stop mode can be monitored through the monitoring speaker or earphone.

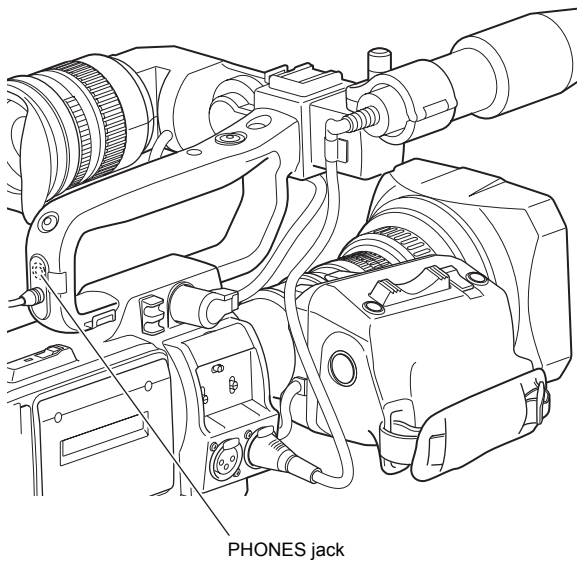

- Select the audio channel to be monitored using the MONITOR SELECT switch.
 - CH-1 : The sound input to the CH-1 channel is output.
 - BOTH : The sound input to the CH-1 and CH-2 channels is output mixed.
 - CH-2 : The sound input to the CH-2 channel is output.
- The MONITOR volume control adjusts the monitoring volume.
- The loudspeaker or earphone outputs an alarm tone in the case of an abnormal condition occurring in this device. An alarm tone is also output when the tape end is reached or when the battery is running down.
 - * Do not increase the audio monitoring volume excessively; otherwise howling with the camera microphone may occur.

Basic Recording Operation

1. Set the POWER switch to ON.
 - This device turns on in camera mode.
2. Start recording.

Press the REC/VTR trigger button on the GY-HD250/GY-HD251 to start recording.

Once recording has started, the FRONT TALLY lamp and BACK TALLY lamp light red.

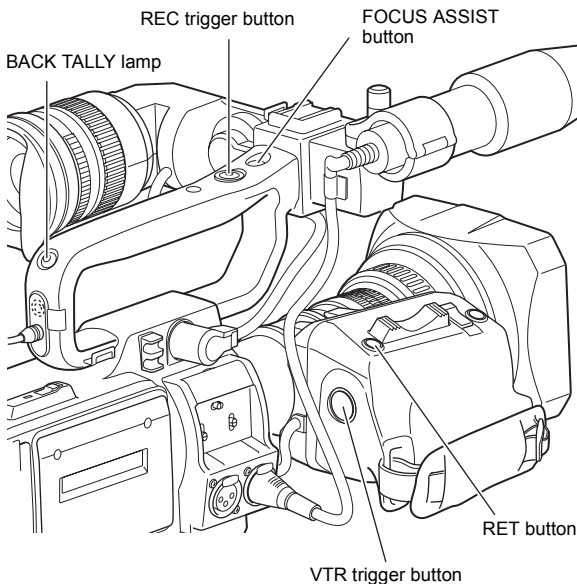
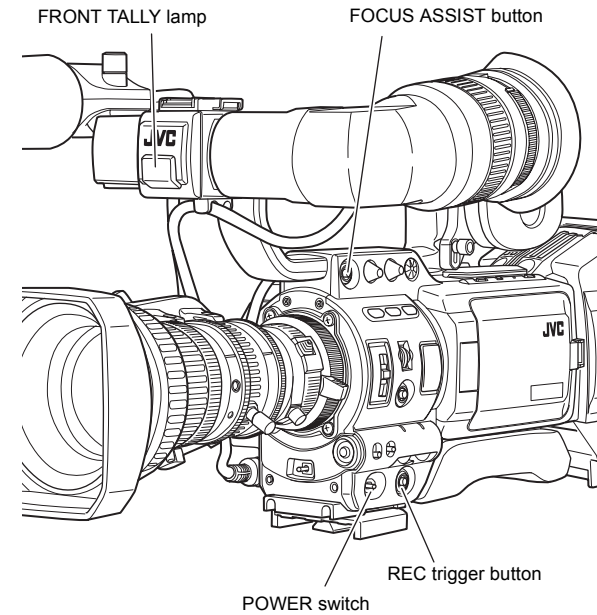

MEMO

The way the FRONT TALLY and the BACK TALLY lamps flash differ depending on what you set in the FRONT TALLY and BACK TALLY items on the OTHERS[1/2] menu screen. See page 96.

CAUTION

- This device enters the stop mode automatically at TAPE END. If this mode continues for 3 minutes, the mode switches to the tape protect mode.
 - See “OTHERS[1/2] Menu Screen” on page 96. (LONG PAUSE TIME item)
- If the REC/VTR trigger button is pressed very quickly and repeatedly, or the POWER switch is moved immediately after the trigger button is pressed, the GY-HD250/GY-HD251 may not enter the record mode.

To remedy this condition set the POWER switch to OFF and wait for 5 seconds or more before turning the power on again.
- A neat transition to the next recorded scene cannot be guaranteed if a recording is ended by turning the POWER switch or DC power supply OFF, or by removing the battery pack.
- Trial-shooting is always recommended before recording important events to confirm the recording is satisfactory.
- The microphone may pick up the sound of the lens' iris if the iris is changed abruptly or the iris is manually moved abruptly during recording.

About the QUICK REC START Mode

If the REC/VTR trigger button is pressed immediately after the videocassette is inserted, the mode becomes the QUICK REC START mode that enables quick start of recording.

However, when shooting starts in the middle of the tape, a blank space appears as the new scene will not be linked smoothly with the previous image.

Also, the time code does not continue. (Some overlap may also occur.)

About the Focus Assist Function

When you press this button during shooting, the area of focus is displayed in blue, red or green, making it easy to focus accurately.

- See “LCD/VF[1/4] Menu Screen” on page 89.

You can also set this function from the RET button.

- See “SWITCH MODE Menu Screen” on page 86. (LENS RET item)

When FOCUS ASSIST on the LCD/VF[1/4] menu screen is set to ACCU-FOCUS, ACCU FOCUS functions with FOCUS ASSIST. This makes focusing with shallower depth of field easier. ACCU FOCUS automatically turns OFF after approximately 10 seconds. See page 89

If the Record-Standby Mode Continues

Setting the time before the tape protection mode is engaged
The time before the tape protection mode is engaged from the record-standby mode can be set to 5 minutes or 3 minutes with the LONG PAUSE TIME item on the OTHERS[1/2] screen menu. See page 96.

When the record-standby mode has continued for about 5 minutes or 3 minutes, the GY-HD250/GY-HD251 automatically stops drum rotation in order to protect the tape. (Tape protect mode)

In the tape protect mode, STOP is shown as the VTR mode indication on the LCD monitor and in the viewfinder screen. (STATUS 1 screen)

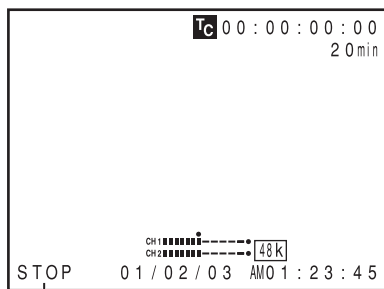

VTR mode indication

- To start recording from the tape protect mode, press the REC/VTR trigger button.
 - The drum starts rotating, and recording starts after about 3 seconds.
- To return to the record-standby mode from the tape protect mode, press the RET button.

CAUTION

This function does not work when using RET button is used as FOCUS ASSIST button.

Checking Recorded Contents in Record-Standby Mode (Recording Check Function)

This function is available only when the GY-HD250/GY-HD251 is in the standby mode.

In standby mode, about 5 seconds of the last part of the content recorded in DV format can be played back, and about 7 seconds when the content was recorded in HDV format can be played back.

- The recorded contents can be checked on the LCD monitor, in the viewfinder or on a monitor connected to the video signal output connectors.

1. In the record-standby mode, press the RET button on the camera lens section.

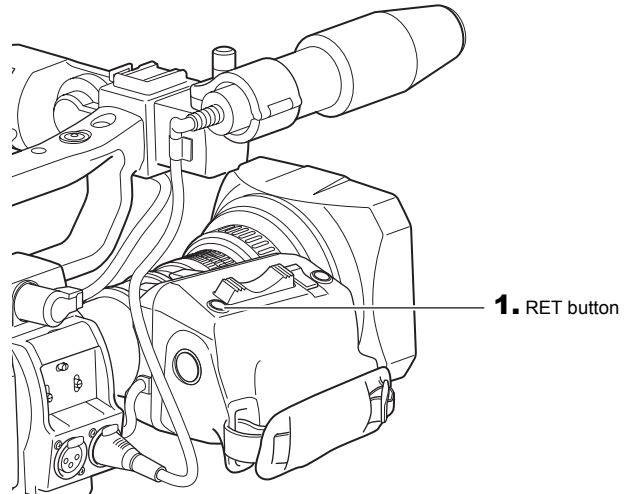

- The tape rewinds and about 6 seconds of the content recorded in DV format is played back, and about 8 seconds of the content recorded in HDV format is played back. After playback, this device returns to standby mode at the position on the tape where the RET button was pressed.
- If you continue to hold down the RET button, up to about 18 seconds of content recorded in DV format and up to about 20 seconds of content recorded in HDV format can be rewound and played back.
 - Pressing the REC/VTR trigger button during playback will put this device in REC standby mode. The camera will automatically return to recording mode after playback.

CAUTION

- This function does not work when using RET button is used as FOCUS ASSIST button.
- This function does not work when the GY-HD250/GY-HD251 is in the stop mode.
- During recording check, the following indication will appear if the error rate increases due to head clogging, etc.
"HEAD CLEANING REQUIRED!" is shown on the LCD monitor or in the viewfinder. (When the STATUS 0, 1, 4 screen is displayed.)

HEADER REC Function

When the REC/VTR trigger button is pressed while the STOP button is pressed, this function first records the color bar video and the test tone (1 kHz sine-wave) of the built-in signal generator at the beginning of the tape. Then it records the black video signal and the mute audio signal for the duration specified in advance. When the recording is completed, this device enters the Record-Standby mode. The time code value at the Record-Standby position becomes the time code specified in advance. (HEADER REC function)

- Settings related to the HEADER REC function, such as whether the HEADER REC function should be enabled, the HEADER REC execution duration, and the time code value setting when the HEADER REC recording is completed, etc., are made on the HEADER REC menu screen.
- The HEADER REC function is enabled when TCG SOURCE on the TC/UB/CLOCK menu screen is set to INTERNAL.
- The HEADER REC function is executed under the following circumstances:
CAM/VTR button: Set to CAM mode.

In the Record-Standby or Stop mode

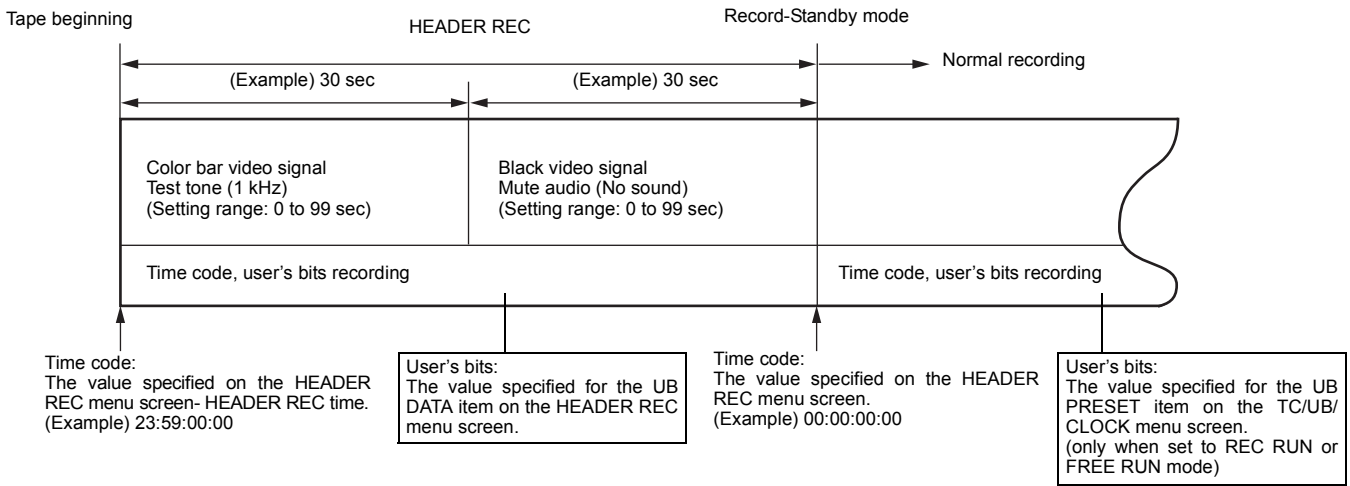

■ HEADER REC menu screen contents

Item	Function/Initial Setting
START KEY	Sets whether the HEADER REC operation should be executed when the REC/VTR trigger button is pressed while the STOP button is pressed. DISABLE : HEADER REC operation is not executed. STOP+REC : HEADER REC operation is executed.
TC DATA	Sets the time code value for the point when the Record-Standby mode is engaged following completion of HEADER REC. EXECUTE : Confirms the set time code. ZERO PRESET: Resets all time codes to zero "0". CANCEL : Clears the set time code. The frame mode is set depending on the setting in the DROP FRAME item on the TC/UB/CLOCK menu screen. * The time code value at the point when the Record-Standby mode is engaged may differ some frames from the value set for this item.
UB DATA	Sets the user's bits of the HEADER REC section. EXECUTE : Confirms the set user's bits. ZERO PRESET: Resets all user's bits data to zero "0". CANCEL : Clears the set user's bits. MEMO The user's bits for the normal recording section are set on the TC/UB/CLOCK menu screen.
BARS TIME	Sets the duration (seconds) in which the color bar signal and test tone (1 kHz) is recorded during HEADER REC. (1-sec steps) [Initial Setting: 0SEC - 30SEC - 99SEC]
BLACK TIME	Sets the duration (seconds) in which the black signal is recorded during HEADER REC. (1-sec steps) [Initial Setting: 0SEC - 30SEC - 99SEC]
PAGE BACK	The TC/UB/CLOCK menu screen returns when the SHUTTER dial is pressed.

How to set the HEADER REC menu screen

1. Display the HEADER REC menu screen.

- ① Select the TC/UB/CLOCK.. item on the TOP MENU screen.
- ② Select the HEADER REC item on the TC/UB/CLOCK menu screen.

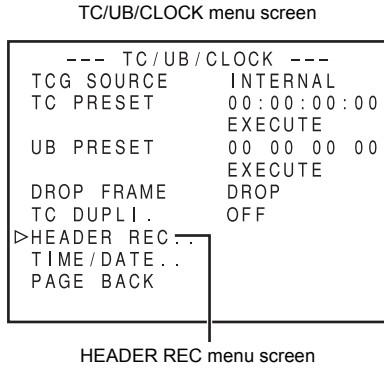

2. Setting the HEADER REC menu screen.

- ① Select the menu item.
Rotate the SHUTTER dial to align the cursor (▶) with the item to be set, and then press the SHUTTER dial.
 - The setting area of the selected item starts blinking.
- ② Changing the setting value.
Rotate the SHUTTER dial to change the setting, and then press the SHUTTER dial.

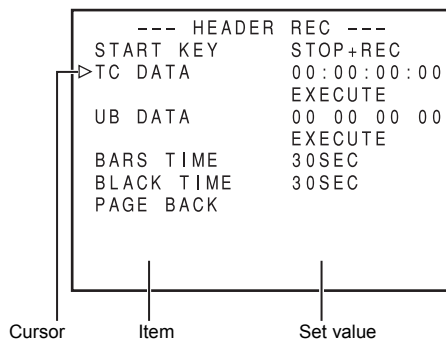

- In the case of the TC DATA item and the UB DATA item, the blinking digit position moves when the SHUTTER dial is pressed. When the SHUTTER dial is rotated, the value of the blinking digit changes. After all the digits have been set and the SHUTTER dial is pressed, EXECUTE starts blinking. Press the SHUTTER dial once more to confirm the set value.

3. To terminate the setting, press the STATUS button.

Executing the HEADER REC Function

The START KEY item on the HEADER REC menu screen should be set to STOP+REC.

1. Load the cassette and engage the Record-Standby mode or the Stop mode.
2. While pressing the STOP button, press the REC/VTR trigger button.
 - The tape automatically rewinds to the beginning, and HEADER REC operation starts from the beginning of the tape.
 After HEADER REC recording is performed for the

specified duration only, the Record-Standby mode is engaged automatically.

- During HEADER REC recording, "HEADER REC" is shown (blinking) on the LCD monitor and in the viewfinder.

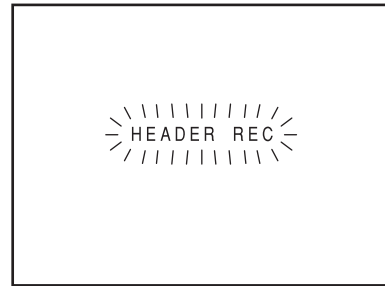

During HEADER REC

- The menu screen is not displayed during HEADER REC recording.

3. After HEADER REC recording is completed and the Record-Standby mode is engaged, normal recording starts when you press the REC/VTR trigger button.

- When the TC GENE. switch is set to either REC or REGEN, the time code value at the start of the HEADER REC menu screen.

MEMO

- To stop during HEADER REC operation, press the REC/VTR trigger button or the STOP button.
- The HEADER REC menu screen cannot be opened during HEADER REC recording.
- HEADER REC operation is accepted even during loading of the cassette tape.
- The test tone (1 kHz sine-wave) recorded in the color bar section will be recorded unrelated to the setting for the TEST TONE item on the AUDIO/MIC[1/2] menu screen.
- The time code preset on the TC/UB/CLOCK menu screen becomes invalid when HEADER REC recording is performed.
- The user's bits following completion of HEADER REC recording will be the user's bits value set on the TC/UB/CLOCK menu screen.
- The running of the time code following completion of HEADER REC recording will be in accordance with the setting of the TC GENE. switch.
FREE RUN : Continuous running.
REC RUN or REGEN: Runs only during REC.
- Camera images are not output to the LCD monitor, viewfinder or video output during REW mode when the HEADER REC operation begins.

Playback Procedure

Recorded pictures can be viewed in the viewfinder, or on the LCD monitor, or on the monitor connected to the video output connector.

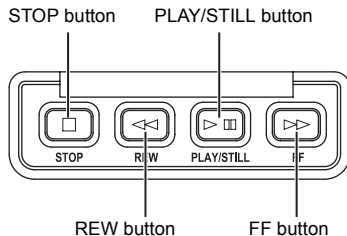

MEMO

The GY-HD250/GY-HD251 can play back the following two types of videocassettes:

- MiniDV videocassette
- DVCAM videocassette

Tapes recorded in the LP mode cannot be played back.

1. Set the POWER switch to ON.
2. Set this device to the VTR mode.
Press the CAM/VTR button to turn on the VTR indicator.
* Playback is also possible in the Camera mode.
Playback operation becomes possible when the STOP button is pressed to set the VTR operation mode indicator to indicate STOP.
3. Load the recorded videocassette correctly.
 - When the videocassette is loaded, this device enters the Stop mode.
4. Open the operation cover on the upper section of this device.
Slide the operation cover to the side to open.
5. Press the PLAY/STILL button.
 - Playback starts.
6. Press the PLAY/STILL button to stop playback temporarily.
 - This device enters the still mode.
7. To re-start playback, press the PLAY/STILL button.
8. To stop playback or the still mode, press the STOP button.

MEMO

- In the VTR mode, the camera image is not output on the LCD monitor, in the viewfinder or through the video output connector.
- When the still picture mode or stop mode has continued for a while, this device automatically switches to the tape protect mode.
Tape protect mode : Drum rotation is stopped in order to protect the tape.
- Noise may appear in the picture in the still mode.

- When the automatic tracking function is activated at the start of the playback mode, digital noise may appear in the playback image.
- This device does not allow manual tracking adjustment.
- When playing back a tape that was recorded on another unit, digital noise may appear during playback.
- Following loading of the tape, the built-in head cleaner will emit a sound while operating. This does not indicate a malfunction.
- The data recorded for the date and time or time code on the tape can be shown on the screen. To enable or disable the display is selected on the menu screen:

Display of date and time : TIME/DATE menu screen
Display of time code : LCD/VF[1/2] menu screen

Fast-Forward, Rewind

- Press the FF button in the stop mode to fast forward the tape. Press the REW button in the stop mode to rewind the tape. (VTR mode only)
* "SWITCH TO VTR MODE" is displayed and the function does not work if the "FF" or "REW" buttons are pressed when Camera mode is in the stop mode.
- Press the STOP button to stop fast forwarding or rewinding.

MEMO

- When the tape approaches the end during fast forwarding or rewinding, the tape speed decelerates to protect the tape.
- The time required for fast forwarding and rewinding may become longer when used in a cold environment. This is not a malfunction.

Search

- Press the FF button in the play mode or still mode to search the tape in the forward direction. Playback takes place while fast forwarding.
Pressing the REW button executes search of the tape in the reverse direction. Playback takes place while rewinding.
(Each press on the button switches the speed to $\times 2$, $\times 5$, and $\times 10$.)
- Press the PLAY/STILL button to resume normal playback.
- Press the STOP button to stop.

MEMO

- To output sound during the search, set the SEARCH AUDIO [DV] item on the AUDIO menu screen to ON.
- Block noise may appear in the picture or the image may freeze during the search.

Outputting Audio

Setting

Confirm that the GY-HD250/GY-HD251 is in the VTR mode. (VTR indicator: On)

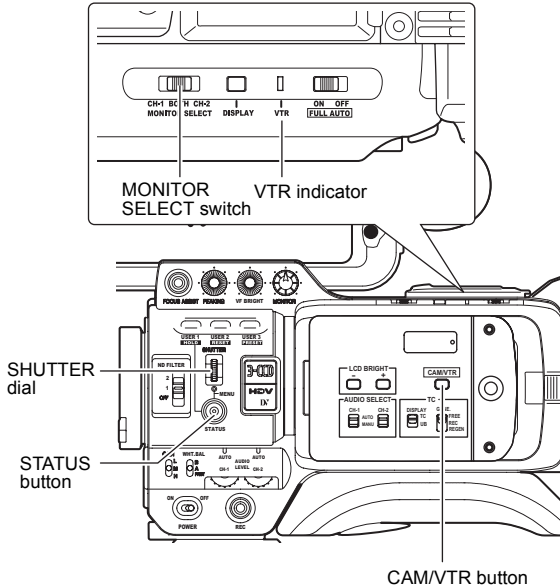

AUDIO menu screen

--- AUDIO ---	
TEST TONE	ON
AUDIO REF. LEVEL	-20 dB
AUDIO MONITOR	MIX
SEARCH AUDIO [DV]	ON
▶ PB AUDIO CH [DV]	CH1 / 2
PAGE BACK	

■ Earphone terminal output audio

Audio output is as shown in the table below depending on the MONITOR SELECT switch and AUDIO MONITOR and PB AUDIO CH [DV] settings on the AUDIO menu screen.

MONITOR SELECT	PB AUDIO CH [DV]			
	AUDIO MONITOR	CH1/2	MIX	CH3/4
CH-1	-	L/R: CH1	L/R: CH1+CH3	L/R: CH3
BOTH	MIX STEREO	L/R: CH1+CH2 L: CH1 R: CH2	L/R: CH1+CH2+CH3+CH4 L: CH1+CH3 R: CH2+CH4	L/R: CH3+CH4 L: CH3 R: CH4
CH-2	-	L/R: CH2	L/R: CH2+CH4	L/R: CH4

* In HDV format, you can only select the settings within the bold frame.

1. Display the AUDIO menu screen.
Select the AUDIO item on the TOP MENU screen.

2. Set the AUDIO menu screen.

- PB AUDIO CH [DV] Items

CH1/2 : To reproduce the sound (CH-1, CH-2) recorded during shooting.

MIX : To reproduce the sound recorded during shooting (CH-1, CH-2) and the after-recorded sound (on CH-3 and CH-4) simultaneously.

CH3/4 : To reproduce the sound after-recorded on CH-3 and CH-4.

PB AUDIO CH [DV]	AUDIO OUT connector	
	CH-1	CH-2
CH1/2	CH1	CH2
MIX	CH1+CH3	CH2+CH4
CH3/4	CH3	CH4

For HDV format, audio is output to CH1 and CH2 no matter the settings.

3. Either of the following operations returns you to the normal screen.

- Press the STATUS button

or

- Return to the TOP MENU screen, select the EXIT item and press the SHUTTER dial.

MEMO

- The DV format is capable of recording up to 4 channels when the 12-bit, 32 kHz sampling frequency is employed. The GY-HD250/GY-HD251 records audio on the two channels CH-1 and CH-2. (4-channel recording is possible in the case of DV input.)

When the GY-HD250/GY-HD251 is used for playback of a tape that was recorded on another unit with audio recorded on the CH-3 and CH-4 channels, the PB AUDIO CH [DV] item on the AUDIO menu screen must be set.

After-recording on the CH-3 and CH-4 channels is not possible.

- The PB AUDIO CH [DV] item is also valid for embedded audio.
- The sampling frequency for embedded audio is 48 kHz.

Connecting the Video Signal Cables

Connecting the IEEE1394 Cable

To reduce the emission of unwanted radio waves, be sure to attach the clamp filter as shown in the figure below.

- Attach the clamp filter as close to this device as possible, as shown in the figure.
- Set the IEEE1394 switch on the left panel of this device.
 - DV : DV format
 - HDV : HDV format

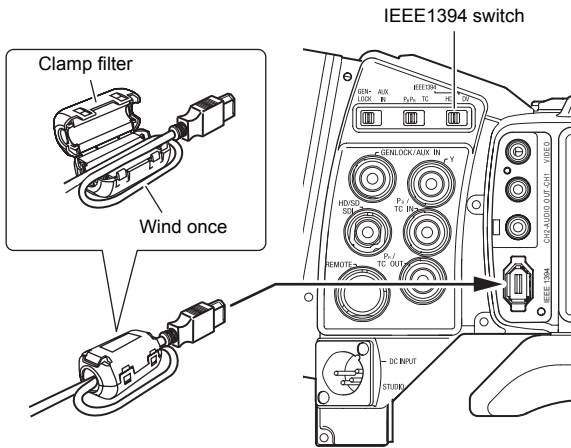

Displaying Alarms

- CHANGE 1394 SWITCH
 Displayed when the setting for the input/output video format from the IEEE1394 connector and the setting for the IEEE1394 switch are different.
 Set the IEEE1394 switch so it matches the video format.

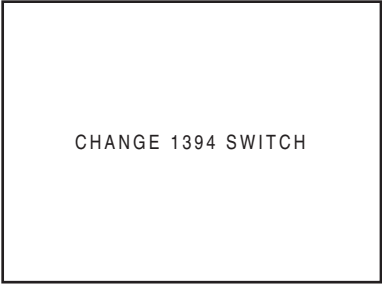

CAUTION

When connecting the IEEE1394 cable from/to Camcorder, VCR and other IEEE1394 device, make sure the following instructions, otherwise the IEEE1394 circuit device may be destroyed.

- Turn the power of both devices OFF and connect the IEEE1394 cable.
- Do not insert incorrectly (in reverse) the IEEE1394 cable end to IEEE1394 port of both devices.

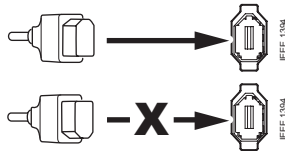

- Do not connect the IEEE1394 cable under the condition of static electricity.
- Turn the power of both devices OFF when changing the IEEE1394 switch from/to HDV/DV.

Recording Composite Video Signals from an External Device

This device features an AUX IN terminal and can record composite video signals from external devices.

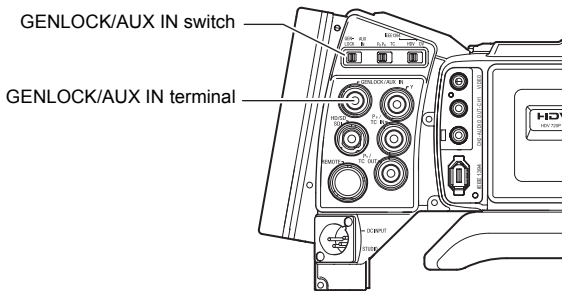

Connection

- Input analog composite video signals from an external device to the GENLOCK/AUX IN terminal.

MEMO

Input composite video signals with no jitter.
Input level: 1.0V ± 0.3V (p-p)

Setting

- Set this device to camera mode:
If the VTR indicator is lit, press the [CAM/VTR] button and turn off the indicator.
- Set the GENLOCK/AUX IN switch to AUX IN.
- Set REC on the VIDEO FORMAT[1/2] menu screen as follows.
U model: DV-60I
E model: DV-50I
- Set SET UP item on the VIDEO FORMAT[2/2] menu screen as follows. (Only for U model)
ON : Set to this when input analog signals include the setup signal.
OFF : Set to this when input analog signals do not include the setup signal.

Operation

- Start and stop recording with the REC/VTR trigger button.
 - EE images of input signals are output in DV-60I (U model) or DV-50I (E model) formats from the various image output terminals.

CAUTION

- Recording cannot be checked using the lens RET button when recording external image signals.
- Do not touch GENLOCK/AUX IN switch during recording.

Status Screen Display on the LCD Screen or Viewfinder

- "AUX" is displayed at the top left with signal format (DV60I or DV50I).

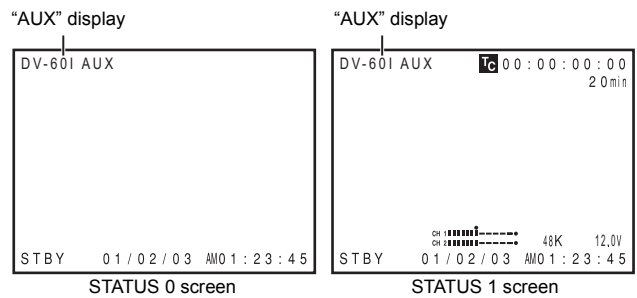

Using GENLOCK Functions

This device features a GENLOCK IN terminal. Input external synchronization signals in the GENLOCK IN terminal to synchronize camera images or playback images with external signals.

Additionally, the H (horizontal) and SC (subcarrier) phase adjustments can be performed on image signals of this device for external synchronization signals from the GENLOCK menu screen.

GENLOCK functions are only valid in Camera mode. They do not work in VTR mode.

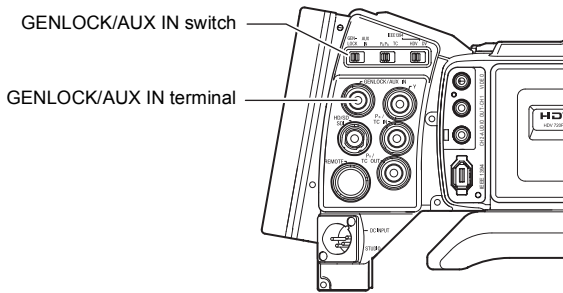

Connection

■ During Standby or Stop mode, input synchronization signals from a Sync signal generator to the GENLOCK/AUX IN terminal.

- The following synchronization signals are applicable.
- SD synchronization signal: BB (Black burst) signals
 - SMPTE170M (RS-170A)-compliant for NTSC
 - ITU-R BT.470-6-compliant for PAL
 - HD synchronization signal: HDTV Tri-sync signals
 - SMPTE296M-compliant for HD720p
 - SMPTE274M-compliant for HD1080i

CAUTION

- When the FRAME RATE is set to 60/30 or 24 in the VIDEO FORMAT[1/2] menu screen, input a 59.94 Hz synchronization signal (vertical synchronization). 50 Hz/60 Hz synchronization signals cannot be synchronized. If the FRAME RATE is set to 50/25, input a 50 Hz synchronization signal. 59.94 Hz/60 Hz synchronization signals cannot be synchronized.
- Do not connect or disconnect the cable during recording or playback.
- When the power is turned on while the external synchronization signal is input, a vertical vibration occurs for a few seconds. This is not a malfunction.
- VTR playback signals with jitter cannot be synchronized with this device.

Setting

- Set this device to Camera mode.
- Set the GENLOCK/AUX IN switch to GENLOCK.
 - When the camera image is locking to external synchronization signals, "SYNC LOCKING" is displayed on the screen. When locking to external synchronization signals is complete, the indication disappears and you can enter recording mode.

Synchronized Signals

The synchronized signal differs depending on the input sync signal.

Refer the table below.

Terminal	Video signal	Input sync signal		
		BB	Tri-sync	
			720p	1080i
VIDEO	Composite	SC,H,V,F	V	V,F
Y/Pb/Pr	SD Component	H,V,F	V	V,F
	HD Component 720p	V	H,V	V
	HD Component 1080i	V,F	V	H,V,F
	SD RGB	H,V,F	V	V,F
	SD Y/C	SC,H,V,F	V	V,F
HD/SD-SDI	SD-SDI	H,V,F	V	V,F
	HD-SDI 720p	V	H,V	V
	HD-SDI 1080i	V,F	V	H,V,F

SC : Subcarrier phase H: Horizontal phase
V : Vertical phase F : Field phase

Adjust SC PHASE and H PHASE in the above table from the GENLOCK menu screen.

Adjust SC and H PHASE

1. Display the GENLOCK menu screen.
Follow the steps in "Setting Menu Screens" on page 75 and proceed as follows.
MENU→OTHERS→GENLOCK
 2. In the GENLOCK menu screen, select the item to perform phase adjustment for and adjust.
 - SD H PHASE : Adjust the H phase in SD analog signals. (During BB signal input)
 - HD H PHASE : Adjust the H phase in HD analog and SD/HD SDI signals. (During Tri-sync signal input, PHASE of SD analog signals are simultaneously adjusted in HD H PHASE item.)
 - SC PHASE : Adjust the SC phase in composite and YC signals.
- For details, refer to "GENLOCK Menu Screen" on See page 99.

MEMO

- H PHASE cannot be adjusted during playback or recording.
- IEEE1394 output stops while H PHASE is being adjusted.
- When values for SD H PHASE or HD H PHASE is changed, the images cannot be produced properly momentarily. This is not a malfunction.

Dubbing with AV Devices

By connecting the video signal output terminal and the AUDIO OUTPUT terminal on GY-HD250/GY-HD251 to an AV device, analog signal dubbing is possible.

1. Connect the cables.

Composite cable
or
Component cable

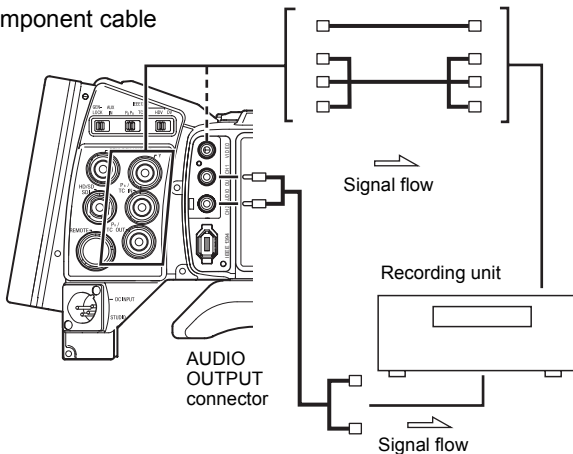

2. Turn both devices on.

3. Set this device to VTR mode.

Press the CAM/VTR button. The VTR indicator lights.

4. Set the video output.

Set the VIDEO FORMAT menu screen. See page 77.

VIDEO FORMAT menu screen

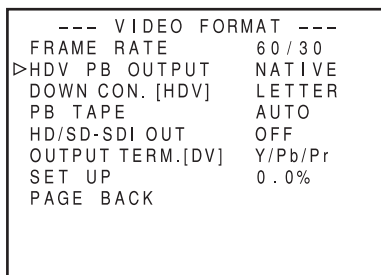

• **HDV PB OUTPUT item:**

Set the video format to be output from the video output terminal during tape playback.

• **PB TAPE item:**

Select whether to automatically detect the playback tape video format or play back only a particular format. Normally, use the "AUTO" setting.

• **OUTPUT TERM. [DV] item:**

Set component, RGB or Y/C signals for the output image signals of the [Y/PB/PR] terminal. (Only for DV format)

5. Set the audio output. See page 63.

Set the AUDIO menu screen. See page 87.

AUDIO menu screen

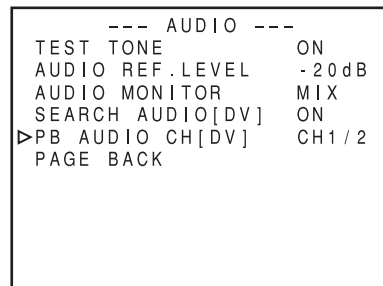

• **PB AUDIO CH [DV] item:**

Set the audio channel to be output.

6. Insert the videocassettes.

GY-HD250/GY-HD251 : Insert the recorded videocassette.

Recording unit : Insert the videocassette to be dubbed to.

7. Press the PLAY/STILL button on the GY-HD250/GY-HD251 to start playback.

8. Start recording on the recording unit.

For details, see the instructions to the unit used for recording.

9. When dubbing is completed.

Stop recording on the recording unit, and then press the STOP button on the GY-HD250/GY-HD251 to stop playback.

HDV/DV Dubbing

Connecting the GY-HD250/GY-HD251 to another video component equipped with HDV/DV connector (IEEE1394 standard) using a IEEE1394 cable (optional) enables dubbing of digital signals with high picture quality and high-quality sound.

Using the GY-HD250/GY-HD251 as the playback unit (Dubbing to another video)

1. Set the IEEE1394 switch on the left panel of this device.
 DV : When dubbing in DV format
 HDV : When dubbing in HDV format
2. Connect the IEEE1394 cable.
3. Turn both devices on.
4. Set this device to VTR mode.
 Press the CAM/VTR button. The VTR indicator lights.

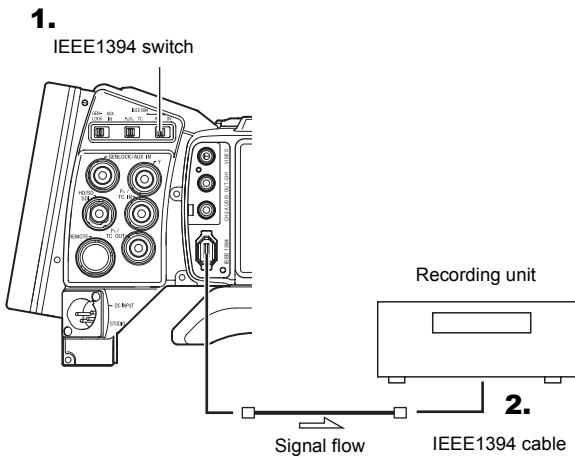

CAUTION

- Set the IEEE1394 switch on both devices to either HDV or DV.
- Start recording after making sure that both devices are properly connected.

5. Set the PB TAPE item on the VIDEO FORMAT menu screen. See page 79.
 Select whether to automatically detect the playback tape video format or play back only a particular format.
 Normally, use the "AUTO" setting.

VIDEO FORMAT menu screen

--- VIDEO FORMAT ---	
FRAME RATE	60 / 30
HDV PB OUTPUT	NATIVE
DOWN CON. [HDV]	LETTER
▷ PB TAPE	AUTO
HD/SD-SDI OUT	OFF
OUTPUT TERM.[DV]	Y/Pb/Pr
SET UP	0.0%
PAGE BACK	

6. Insert a videocassette tape.
 GY-HD250/GY-HD251 : Recorded videocassette tape
 Recording unit : Videocassette you want to dub
7. Press the PLAY/STILL button on GY-HD250/GY-HD251 to start playback.
8. Start recording on the recording device.
 See the recording device user manual for more information.
9. When dubbing is finished, stop recording on the recording device, press the STOP button on this device, and stop the playback.

MEMO

- Switch the IEEE1394 switch when this device is OFF.
- When you dub still images, they are low resolution images. Noise may also enter the audio.
- Operations may differ depending on the features and specifications of the connected device, and operations or data exchange may not be possible even if the devices are connected.
- If noise appears on the screen or the audio cuts out, reconnect the IEEE1394 cable or turn the GY-HD250/GY-HD251 on again.
- If you turn the power to the device connected to the IEEE1394 connector on and off or switch the video input, noise may occur in the audio. If you perform this type of operation, set the speaker volume as low as possible on the audio device connected to this device.
- Recording may not be possible in some cases even if the recorder is equipped with a IEEE1394 connector.

When Using the GY-HD250/GY-HD251 as Recording Unit (Dubbing From Another Videocassette)

1. Set the IEEE1394 switch on left side of the GY-HD250/GY-HD251.
DV : When dubbing in DV format
HDV : When dubbing in HDV format
2. Connect the units with the IEEE1394 cable.
3. Turn ON both units.
4. Place the GY-HD250/GY-HD251 in the VTR MODE.
Press the CAM/VTR button to turn on the VTR indicator.
5. Set the frame rate.
Set the FRAME RATE item (60/30, 50/25, 24) on the VIDEO FORMAT[1/2] menu to match the HDV/DV signal frame rate input from the IEEE1394 connector.
☞ See page 77.

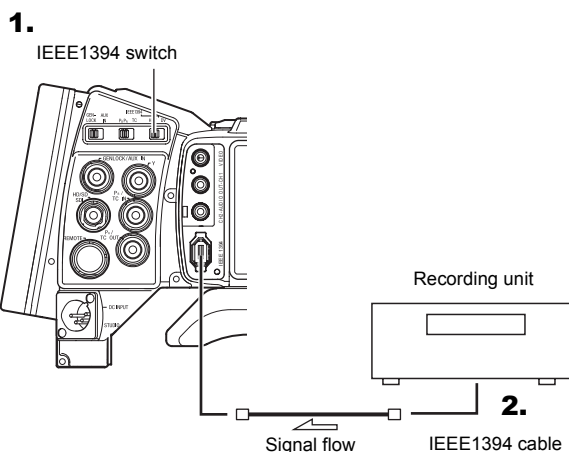

CAUTION

- Set the IEEE1394 switch on both devices to either HDV or DV.
- Start recording after making sure that both devices are properly connected.

6. Set the time code and user bit recording.
Set the TC DUPLI. item on the TC/UB/CLOCK menu screen.
OFF : Records the TC/UB set in this device.
ON : Records the TC/UB for the IEEE1394 input.
Date and time data : Records the data sent from the playback device in DV format.
Records the data of the internal clock in HDV format.

MEMO

In HDV format, the UB set in this device is recorded regardless of the setting.

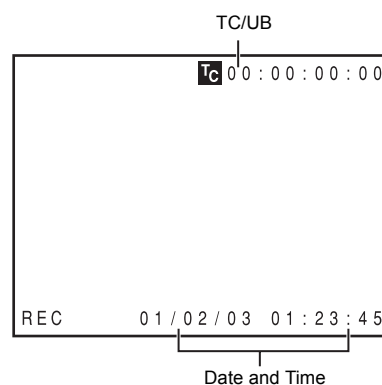
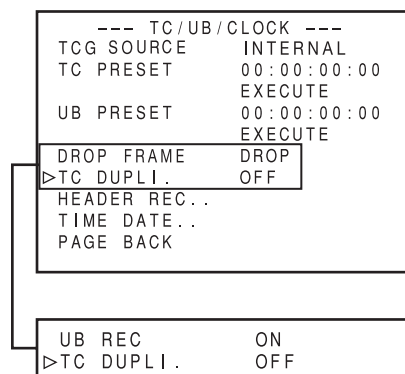

7. Insert the videocassettes.
GY-HD250/GY- : Insert the videocassette to be dubbed HD251 to.
Playback unit : Insert the recorded videocassette.
8. Start playback on the playback unit.
For details, see the instructions to the unit used for playback.
 - The playback picture from the playback unit appears on the GY-HD250/GY-HD251's LCD monitor and viewfinder screen.
9. Press the REC/VTR trigger button on the GY-HD250/GY-HD251 to start recording.
 - To temporarily pause the recording, press the REC or VTR trigger button.
 - To restart the recording, press the REC or VTR trigger button again.
10. When dubbing is completed.
Press the REC/VTR trigger button or the STOP button on the GY-HD250/GY-HD251 to stop recording, and then stop playback on the playback unit.

MEMO

Depending on the player, sound may not be heard momentarily from this device when switching modes from STILL to PLAY.

Backup Recording

Backup Recording of the GY-HD250/GY-HD251's Camera Image and Sound Through the IEEE1394 Connector

The GY-HD250/GY-HD251's camera image and sound can be recorded for backup on another component that is equipped with IEEE1394 connector.

Connections

Use the GY-HD250/GY-HD251 as the master unit. Connect the master unit and the backup unit with a IEEE1394 cable.

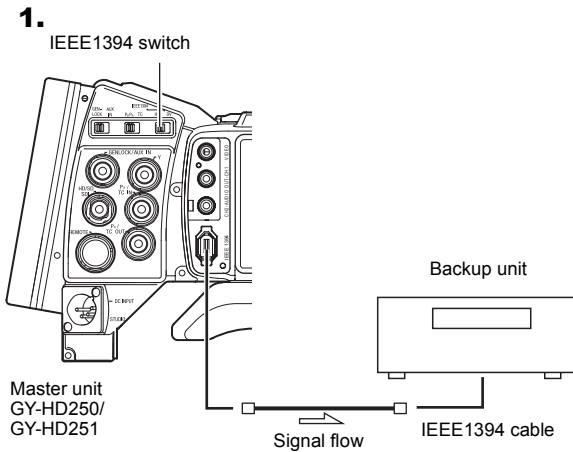

Settings

- Master unit (GY-HD250/GY-HD251)
 1. Set the IEEE1394 switch on left side of the GY-HD250/GY-HD251.
 - DV : When backup in DV format
 - HDV : When backup in HDV format
 2. Place in Camera mode.
 3. Set the 1394 REC TRIG. item on the OTHERS[2/2] menu screen. See page 97. For HDV mode, set the BACK SPACE [HDV] item. See page 97.

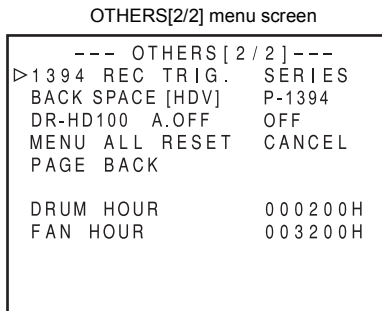

- Backup unit
 - Place in HDV/DV signal input mode.
 - * Depending on the used component, it may be necessary to set "REMOTE SELECT".
 - When BR-HD50 is used, set the Backup Recording function to OFF.
 - Also, set REM SEL HDV/DV in the REMOTE[1/2] menu of the BR-HD50 to ON or LOC+REM.
 - Insert the tape and set to STOP or REC PAUSE status.

CAUTION

- Set the IEEE1394 switch on both devices to either HDV or DV.
- Start recording after making sure that both devices are properly connected.
- If the RET button is pressed during backup recording, output from the IEEE1394 terminal is stopped, the image is switched to the image recorded on this device, interrupting the backup recording image.

Operation

Start and stop of recording on the backup unit takes place in accordance with the operation of the REC/VTR trigger button on the master unit. (Depending on the GY-HD250/GY-HD251 or the backup unit, the image, audio, and/or time code may deviate from what they should be at the points where the recording is started or stopped.)

MEMO

- When the backup recording is started, the "TRIGGER TO DV" or "TRIGGER TO HDV" indication is shown on the LCD or in the viewfinder for approx. 3 seconds.
- When the Series Recording function of BR-HD50 is used, the GY-HD250/GY-HD251's 1394 REC TRIG. item should be set to OFF.
- If the backup device is equipped with a feature to record time codes input from the IEEE1394 connector (TC DUPLICATE feature), time code data the same as on the master side can be recorded.
 - If the master unit tape is paused or stopped when the master unit time code running mode is in REC RUN mode, the time code for the slave unit stops.
- When using BR-HD50 as a backup device and switching GY-HD250/GY-HD251 from the playback mode to the record mode, noise will be noticed on the monitor output screen of BR-HD50 (backup will be correctly recorded).

Connect a Remote Control Unit (RM-LP55/RM-LP57)

Set camera switch functions with the remote control unit (RM-LP55/RM-LP57).

Connection

Connect the remote control unit cable to the REMOTE terminal.

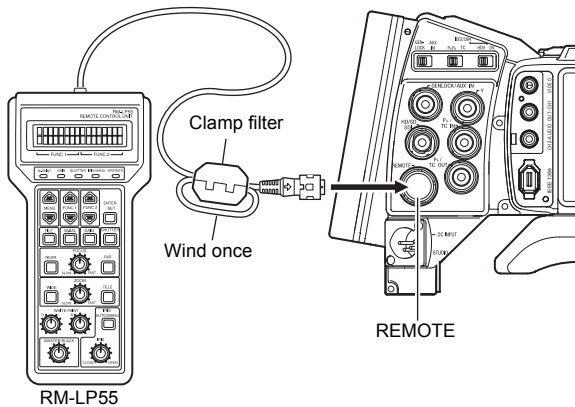

- Attach the clamp filter included with the remote control unit to the remote cable. (The clamp filter can be substituted with the clamp filter included with this device.) Consult your JVC dealer if you do not have a clamp filter.

CAUTION

Turn the power OFF when connecting.

Operation

1. Turn the device ON.
2. Turn ON the OPERATE switch on remote control unit to activate the remote control unit. See page 72 for details on functions that can be operated with the remote control unit.

Notes on Using the Remote Control Unit

- When the switch function of this device and the remote control unit are the same, the remote control switch function is prioritized.
- FOCUS and ZOOM cannot be adjusted with the remote control unit.
- Shutter speed slightly differs from the value displayed on this device.
- **Shutter Speed in 24p Mode**
When this device is in 24p mode, shutter speed cannot be set to 1/60 (U model) or 1/50 (E model) with the remote control unit. Even if shutter speed is set to 1/60 or 1/50 with the remote control unit when in 24p mode, the shutter speed for the device is 1/48.
- When H PHASE adjustment is performed with the remote control unit, only H PHASE of SD signal operates.
- When adjusting H PHASE of SD signal with the remote control unit, it cannot be set outside the range of SD H PHASE in the GENLOCK menu screen. See page 99.
- **AUTO WHITE Function**
When the device is in VTR mode, AUX IN mode, during playback or HEADER REC, the AUTO WHITE function does not work even if the auto white operation is performed with the RM-LP55 and RM-LP57. In the case of the RM-LP55, "LOW LIGHT ERROR" is displayed on the LCD screen of the RM-LP55.

Connect a Remote Control Unit (RM-LP55/RM-LP57) (Cont'd)

Remote Control Unit Functions List

Function		Action	
RM-LP55	RM-LP57		
BARS [OFF/ON]	←		○
CONTOUR [OFF/ON]	←		○
CONTOUR V/H LEVEL	←		○
IRIS [MANU/AUTO]	←		○
IRIS LEVEL	←		○
IRIS DETECT			X
WHT.BAL	AUTO1	←	○
	AUTO2	←	○
	FAW	←	○
	PRESET		○
	MANU		○
AUTO WHITE	←		○
MANUAL WHITE BALANCE R/B LEVEL			○
PAINT R/B LEVEL	←		○
GAIN	0dB	←	○
	6dB	←	○
	9dB	←	○
	12dB	←	○
	LOLUX		X
	-3dB		X
	-6dB		X
	ALC+EEI	←	○
	ALC	←	X
NEGA [OFF/ON]			X
SHUTTER	NORMAL	←	○
	1/100	←	○ *1
	1/120	←	○ *2
	1/250	←	○
	1/500	←	○
	1/1000	←	○
	1/2000	←	○
	1/4000		○
	1/10000		○
	EEI	←	X
	V.SCAN		X
ZOOM	←		X
FOCUS	←		X
HI-RESO [OFF/ON]			X
MASTER BLACK LEVEL	←		○
GAMMA [OFF/ON]			X
GAMMA MASTER LEVEL			X
KNEE MASTER LEVEL			X
TITLE [OFF/ON]			X
TITLE POSITION			X
TITLE CLEAR			X
H PHASE	←		○
SC COARSE [0°/90°/180°/270°]	←		○

SC FINE	←	○
RANDOM SHUTTER		X
VARIABLE SHUTTER LEVEL		X
SLOW SHUTTER LEVEL		X

←: Same as RM-LP55

○: Available

∕: None

X: Not available

*1 Only when frame rate is 60p, 60i, 30p, or 24p

*2 Only when frame rate is 50p, 50i, or 25p

Menu Screen Configuration

The Menu Screen consists of multiple layers of menu screens as shown below. The menu screen to be set is selected from the TOP MENU in accordance with the function or purpose.

The items on the menu screens differ with the Camera mode and the VTR mode. The contents of set items are stored in the GY-HD250/GY-HD251's memory and are retained even when the power is turned off.

The FILE MANAGE menu screen can be used to store the menu setting contents on the GY-HD250/GY-HD251 or SD memory card.

■ Camera Mode

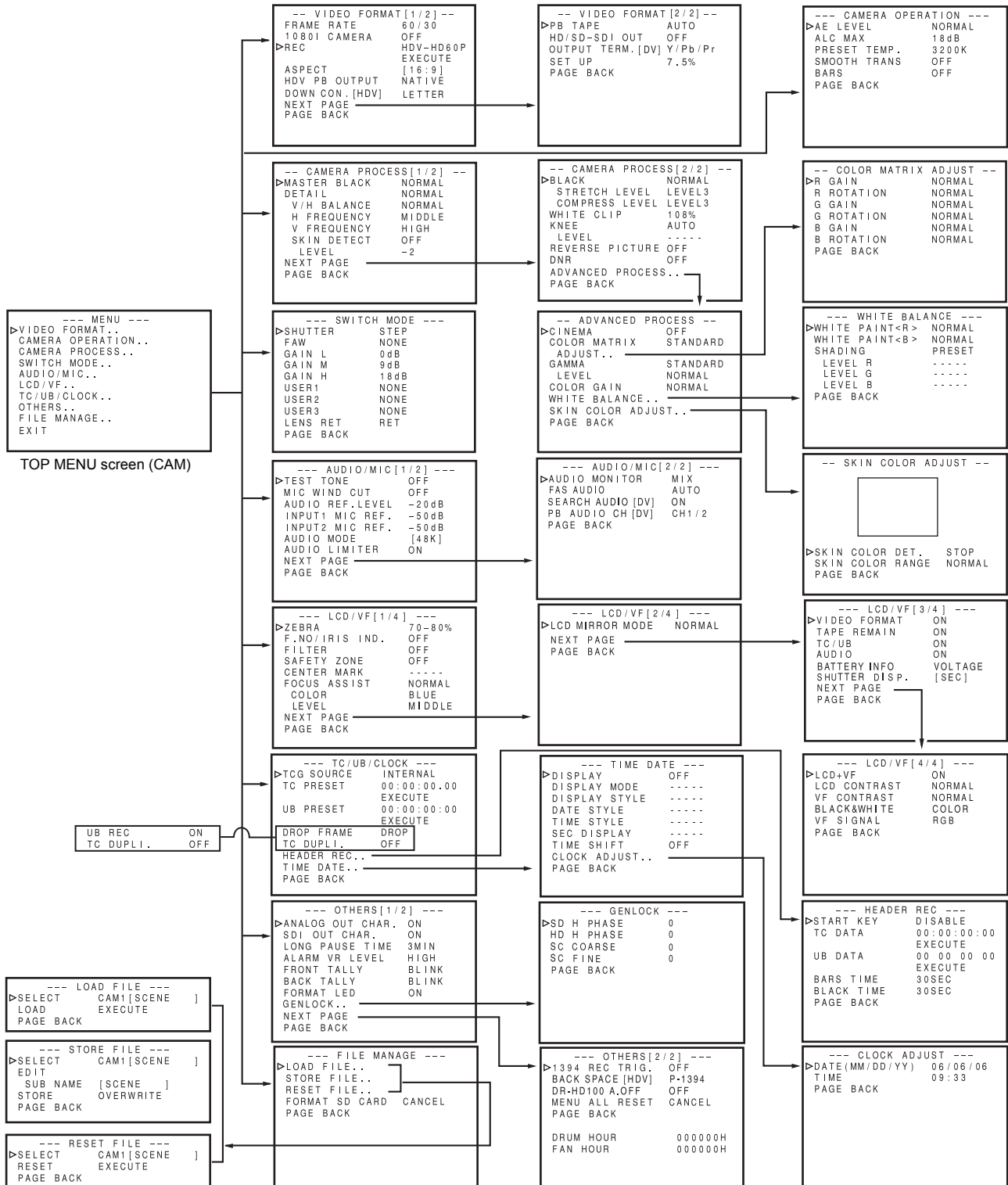

Menu Screen Configuration (Cont'd)

■ VTR Mode/IEEE1394 Input Mode

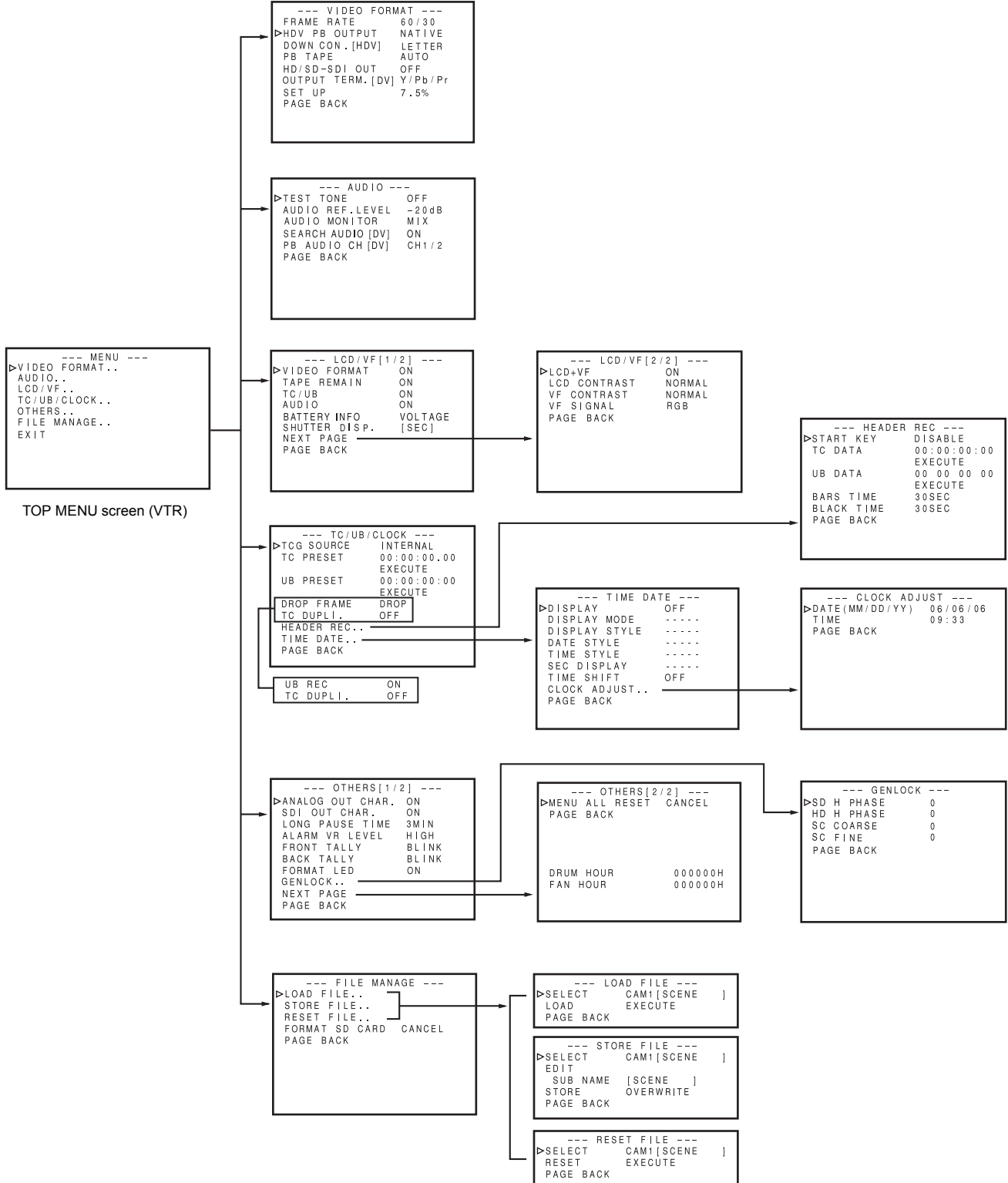

Setting Menu Screens

Make the settings while observing the LCD monitor or the viewfinder screen.

If the ANALOG OUT CHAR. item or SDI OUT CHAR item on the OTHERS[1/2] screen is set to ON, the menu screen can also be viewed on a monitor connected to the video signal output connector.

1. Set the POWER switch to ON.
2. Set the mode of the GY-HD250/GY-HD251 with the CAM/VTR button. (Camera mode or VTR mode)
3. Press the STATUS button for 1 second or longer.
 - The TOP MENU screen appears.

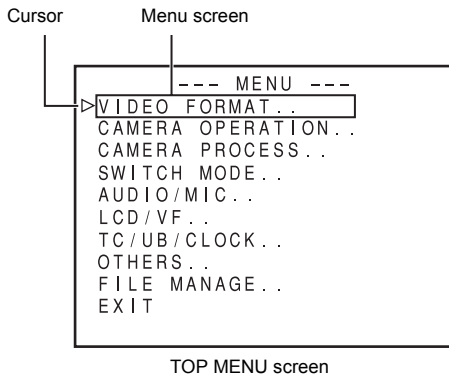
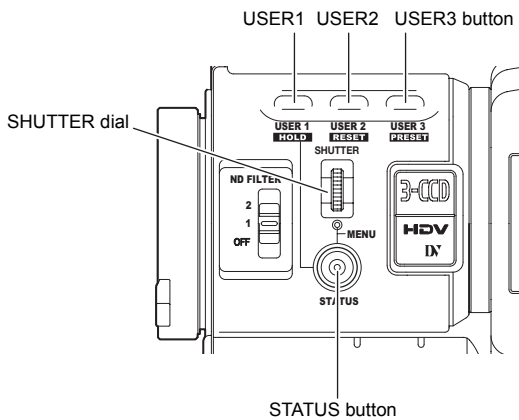

4. Select the menu screen to be set.
 - Rotate the SHUTTER dial to align the cursor (▶) with the menu screen to be set, and then press the SHUTTER dial.
 - The selected menu screen appears.

Item	Setting
-- VIDEO FORMAT [1/2] --	
▶ FRAME RATE	60/30
1080I CAMERA	OFF
REC	HDV-HD60P
	EXECUTE
ASPECT	[16:9]
HDV PB OUTPUT	NATIVE
PB TAPE	AUTO
DOWN CON. [HDV]	SQUEEZE
NEXT PAGE	
PAGE BACK	

VIDEO FORMAT[1/2] menu screen

5. Select the menu item on the menu screen.
 - Rotate the SHUTTER dial to align the cursor (▶) with the item to be set, and then press the SHUTTER dial.
 - The setting area of the selected item starts blinking, and the setting can now be made.
6. Change the setting.
 - Rotate the SHUTTER dial to change the setting, and then press the SHUTTER dial.
 - The setting area stops blinking and the setting is entered.
- To change multiple items, repeat the procedures in steps 5. and 6. above.
7. Return to the TOP MENU screen.
 - Rotate the SHUTTER dial to align the cursor (▶) with the PAGE BACK item, and then press the SHUTTER dial.
 - To change settings on other menu screens, repeat the procedures in steps 4. to 7. above.
 - To save the set contents in FILE, select the FILE MANAGE menu screen and perform the operations for saving to file.
 - ☞ See "FILE MANAGE Menu Screen" on page 100.
8. To return to the normal screen after completing the settings, use either of the following methods.
 - Press the STATUS button
 - or
 - Return to the TOP MENU screen and align the cursor (▶) with the EXIT item, and then press the SHUTTER dial.

MEMO

- While the menu screen is being displayed, the USER1, USER2 and USER3 buttons can also perform menu operations.
 - USER1 button : Raises the cursor (▶)/Changes the setting
 - USER2 button : Lowers the cursor (▶)/Changes the setting
 - USER3 button : Confirms the menu item/Confirms the setting
- The menu screen is not displayed when switching between Camera and VTR mode (VTR indicator flashes).

TOP MENU Screen

Different menu screens are displayed depending on whether the GY-HD250/GY-HD251 is in the Camera mode or in the VTR mode. In the VTR mode, the CAMERA OPERATION, CAMERA PROCESS and SWITCH MODE menu screens are not displayed.

Item	Function
VIDEO FORMAT..	Displays the menu screen for setting the video format for shooting and playing back video. Camera mode: It consists of two screens. VTR mode : It consists of one screen. • The cursor (▶) does not move to this item when this device is recording.
CAMERA OPERATION..	Displays a menu screen for setting the operation mode for camera shooting. • This item is only displayed in the Camera mode.
CAMERA PROCESS..	Displays a menu screen for adjustments of the picture quality of the camera image. It consists of two screens. The ADVANCED PROCESS menu screen, WHITE BALANCE menu screen, and SKIN COLOR ADJUST screen can be displayed through the CAMERA PROCESS menu screen. • This item is only displayed in the Camera mode. • The cursor (▶) does not move to this item when this device is in VTR mode (PLAY, STL, FWD, REV).
SWITCH MODE..	Displays the menu screens related to the camera switch functions. • This item is only displayed when in camera mode.
AUDIO/MIC..	Displays a menu screen related to audio. Camera mode: It consists of two screens. VTR mode : It consists of one screen. • In VTR mode, the screen changes to the AUDIO menu screen. • The cursor (▶) does not move to this item when this device is recording.
LCD/VF..	Displays a menu screen for selecting whether to display characters on the LCD monitor or in the viewfinder, and for adjustments of the picture quality of LCD monitor. Camera mode: It consists of four screens. VTR mode : It consists of two screens.
TC/UB/CLOCK..	Displays a menu screen for setting the time code, user's bit data, date and time. The ways that the date and time are recorded together with the display style are set here. The TIME/DATE menu screen and CLOCK ADJUST screen can be displayed through the TC/UB/CLOCK menu screen. • The cursor (▶) does not move to this item when this device is recording.
OTHERS..	Displays a menu screen for setting other functions and to display the hour meter. It consists of two screens.
FILE MANAGE..	Displays the FILE MANAGE menu screen. Saves the menu screen settings as a file on this device or an SD memory card, or reads the menu screen settings saved in the file. It is also possible to reset the menu settings to default settings or initialize (format) an SD memory card. ☞ See "FILE MANAGE Menu Screen" on page 100. • The cursor (▶) does not move to this item when VTR is activated.
EXIT	The normal screen returns when the SHUTTER dial is pressed while the cursor is aligned with this item.

VIDEO FORMAT[1/2] Menu Screen

The VIDEO FORMAT menu screen consists of two screens (1/2 screen, 2/2 screen).
In VTR mode, this screen consists of one screen.

* This is not displayed in VTR mode.

Item	Function/Setting (bold characters indicate initial settings)																											
FRAME RATE	<p>Sets the frame rate for shooting.</p> <p>U model</p> <p>60/30 : Shoots at 480/60i, 720/60p, 720/30p. 50/25 : Shoots at 720/50p, 720/25p. 24 : Shoots at 480/24p (2:3:2:3 pulldown), 480/24p advance mode (2:3:3:2 pulldown), 720/24p.</p> <p>E model</p> <p>60/30 : Shoots at 720/60p, 720/30p. 50/25 : Shoots at 576/50i, 720/50p, 576/25p, 720/25p. 24 : Shoots at 720/24p. CANCEL : Cancels the settings. EXECUTE : Executes the settings.</p> <p>MEMO</p> <ul style="list-style-type: none"> • If you change the FRAME RATE item setting, the system is rebooted. See page 54. • The cursor (▶) does not move to this item when this device is in VTR mode or is ejecting a tape. 																											
1080I CAMERA*	<p>Selects whether or not to output camera images in HDV1080i signals. HDV1080i signals are output from component output of the Y/Pb/Pr terminal or HD/SD-SDI output terminal. However, they are not recorded on this device.</p> <p>OFF : No HDV1080i signal is output. Output setting of camera images is based on the REC settings below. ON : HDV1080i signal is output. (60/30 Frame rate: 1080/60i, 50/25 Frame rate: 1080/50i) 480/60i or 576/50i signals are output from the VIDEO OUT terminal.</p> <ul style="list-style-type: none"> • ON/OFF is set when the SHUTTER dial is pressed. <p>MEMO</p> <ul style="list-style-type: none"> • Tape recording and IEEE1394 output are not available when this is ON. • REC item cannot be set when this is ON. • The cursor is positioned on 1080I CAMERA in the VIDEO FORMAT[1/2] menu screen when this is ON. • When the FRAME RATE is set to 24, this is fixed to OFF. 																											
REC*	<p>Sets the video format for shooting. (Can only be displayed and set in camera mode) You can set the following according to the FRAME RATE.</p> <table border="1"> <thead> <tr> <th>Setting</th> <th>Description</th> <th>FRAME RATE</th> </tr> </thead> <tbody> <tr> <td>DV-60I</td> <td>DV format Shoots using a 480/60i signal. (U model Only)</td> <td rowspan="3">60/30</td> </tr> <tr> <td>HDV-HD60P</td> <td>HDV format Shoots using a 720/60p signal.</td> </tr> <tr> <td>HDV-HD30P</td> <td>HDV format Shoots using a 720/30p signal.</td> </tr> <tr> <td>HDV-HD50P</td> <td>HDV format Shoots using a 720/50p signal.</td> <td rowspan="3">50/25</td> </tr> <tr> <td>HDV-HD25P</td> <td>HDV format Shoots using a 720/25p signal.</td> </tr> <tr> <td>DV-50I</td> <td>DV format Shoots using a 576/50i signal. (E model Only)</td> </tr> <tr> <td>DV-25P</td> <td>DV format Shoots using a 576/25p signal. (E model Only)</td> <td rowspan="3">24</td> </tr> <tr> <td>DV-24P</td> <td>DV format Shoots at 480/24p (2:3:2:3 pulldown). (U model Only)</td> </tr> <tr> <td>DV-24PA</td> <td>DV format Shoots at 480/24p (2:3:3:2 pulldown). (U model Only)</td> </tr> <tr> <td>HDV-HD24P</td> <td>HDV format Shoots using a 720/24p signal.</td> <td></td> </tr> </tbody> </table> <p>CANCEL : Cancels the settings. EXECUTE : Executes the settings.</p> <p>MEMO</p> <ul style="list-style-type: none"> • The synchronous video signal is momentarily disturbed when the REC item setting is switched. • On the E model, the video format is fixed at HDV-HD24P when the FRAME RATE item is set to "24". "[HDV-HD24P]" is displayed. 	Setting	Description	FRAME RATE	DV-60I	DV format Shoots using a 480/60i signal. (U model Only)	60/30	HDV-HD60P	HDV format Shoots using a 720/60p signal.	HDV-HD30P	HDV format Shoots using a 720/30p signal.	HDV-HD50P	HDV format Shoots using a 720/50p signal.	50/25	HDV-HD25P	HDV format Shoots using a 720/25p signal.	DV-50I	DV format Shoots using a 576/50i signal. (E model Only)	DV-25P	DV format Shoots using a 576/25p signal. (E model Only)	24	DV-24P	DV format Shoots at 480/24p (2:3:2:3 pulldown). (U model Only)	DV-24PA	DV format Shoots at 480/24p (2:3:3:2 pulldown). (U model Only)	HDV-HD24P	HDV format Shoots using a 720/24p signal.	
Setting	Description	FRAME RATE																										
DV-60I	DV format Shoots using a 480/60i signal. (U model Only)	60/30																										
HDV-HD60P	HDV format Shoots using a 720/60p signal.																											
HDV-HD30P	HDV format Shoots using a 720/30p signal.																											
HDV-HD50P	HDV format Shoots using a 720/50p signal.	50/25																										
HDV-HD25P	HDV format Shoots using a 720/25p signal.																											
DV-50I	DV format Shoots using a 576/50i signal. (E model Only)																											
DV-25P	DV format Shoots using a 576/25p signal. (E model Only)	24																										
DV-24P	DV format Shoots at 480/24p (2:3:2:3 pulldown). (U model Only)																											
DV-24PA	DV format Shoots at 480/24p (2:3:3:2 pulldown). (U model Only)																											
HDV-HD24P	HDV format Shoots using a 720/24p signal.																											

VIDEO FORMAT[1/2] Menu Screen (Cont'd)

* This is not displayed in VTR mode.

Item	Function/Setting (bold characters indicate initial settings)																		
ASPECT*	<p>Sets the screen size for the recording video signal. (Can only be displayed and set in camera mode)</p> <p>4:3 : Outputs the video with an aspect ratio of 4:3. 16:9 : Outputs the video with an aspect ratio of 16:9. The resolution in the vertical direction drops compared to 4:3 video.</p> <p>MEMO</p> <ul style="list-style-type: none"> • When the format setting is HDV, the ASPECT item is fixed at 16:9. (“[16:9]” is displayed.) • The synchronous video signal is momentarily disturbed when the ASPECT item setting is switched. 																		
HDV PB OUTPUT	<p>When playing back an HDV recorded tape, set video format for component output from the Y/Pb/Pr terminal or SDI output from the HD/SD-SDI output terminal. You can set the following depending on the FRAME RATE of the HDV recorded tape.</p> <table border="1" data-bbox="389 768 1471 1003"> <thead> <tr> <th>Setting</th> <th>Description</th> <th>FRAME RATE</th> </tr> </thead> <tbody> <tr> <td>NATIVE</td> <td>Outputs the signal being recorded on the tape.</td> <td>60/30</td> </tr> <tr> <td>720P</td> <td>Converts the signal being recorded on tape to 720p and outputs it.</td> <td>50/25</td> </tr> <tr> <td>1080I</td> <td>Converts the signal being recorded on tape to 1080i and outputs it.</td> <td>24</td> </tr> <tr> <td>NTSC</td> <td>Converts the signal being recorded on tape to 480i and outputs it.</td> <td>60/30 24</td> </tr> <tr> <td>PAL</td> <td>Converts the signal being recorded on tape to 576i and outputs it.</td> <td>50/25</td> </tr> </tbody> </table> <p>MEMO</p> <ul style="list-style-type: none"> • If you convert video recorded in HDV format to DV format and output it, the colors may change. • This item is also applied to EE images when HDV signals are input to the IEEE1394 terminal. • Fixed at NATIVE during DV recorded tape playback or DV signal input. 	Setting	Description	FRAME RATE	NATIVE	Outputs the signal being recorded on the tape.	60/30	720P	Converts the signal being recorded on tape to 720p and outputs it.	50/25	1080I	Converts the signal being recorded on tape to 1080i and outputs it.	24	NTSC	Converts the signal being recorded on tape to 480i and outputs it.	60/30 24	PAL	Converts the signal being recorded on tape to 576i and outputs it.	50/25
Setting	Description	FRAME RATE																	
NATIVE	Outputs the signal being recorded on the tape.	60/30																	
720P	Converts the signal being recorded on tape to 720p and outputs it.	50/25																	
1080I	Converts the signal being recorded on tape to 1080i and outputs it.	24																	
NTSC	Converts the signal being recorded on tape to 480i and outputs it.	60/30 24																	
PAL	Converts the signal being recorded on tape to 576i and outputs it.	50/25																	
DOWN CON. [HDV]	<p>Set the style to display down-converted images in aspect ratio 4:3. SQUEEZE : Image that is squeezed horizontally is displayed. LETTER : Wide image with the top and bottom blackened is displayed.</p> <p>MEMO</p> <p>This setting is only valid in HDV mode. In DV mode, the style becomes SQUEEZE regardless of the setting of this item.</p>																		
NEXT PAGE	To display the VIDEO FORMAT[2/2] menu screen, move the cursor to this position and press the SHUTTER dial.																		
PAGE BACK	The TOP MENU returns when the SHUTTER dial is pressed with the cursor at this position.																		

VIDEO FORMAT[2/2] Menu Screen

* This is not displayed in VTR mode.

Item	Function/Setting (bold characters indicate initial settings)																			
PB TAPE	<p>Selects whether to automatically detect the playback tape video format or play back only a particular format. Normally, use the "AUTO" setting.</p> <p>AUTO : During tape playback, the format signal is switched automatically and played back. DV : During tape playback, only the part of the tape recorded in DV format is played back. HDV : During tape playback, only the part of the tape recorded in HDV format is played back. DVCAM : During tape playback, only the part of the tape recorded in DVCAM format is played back.</p> <p>MEMO</p> <hr/> <p>If you play back a tape containing both DV and HDV formats, the video signal is disturbed when the signal is switched.</p>																			
HD/SD-SDI OUT	<p>Sets whether or not to output SDI (Serial Digital Interface) signals from the HD/SD SDI OUT terminal.</p> <p>OFF : No output. ON : Output on. Embedded audio and time code are also output.</p>																			
OUTPUT TERM. [DV]	<p>Sets the output image format for the Y/Pb/Pr terminal in DV format.</p> <p>Y/Pb/Pr : Outputs analog component signals. R/G/B : Outputs analog RGB signals. Y/C : Outputs YC separate signals.</p> <p>Signals are output from terminals as shown in the table below depending on the settings.</p> <table border="1" style="width: 100%; border-collapse: collapse; text-align: center;"> <thead> <tr> <th rowspan="2">Terminal</th> <th colspan="3">Setting</th> </tr> <tr> <th>Y/Pb/Pr</th> <th>R/G/B</th> <th>Y/C</th> </tr> </thead> <tbody> <tr> <td>Y</td> <td>Component Y</td> <td>G</td> <td>Y</td> </tr> <tr> <td>Pb</td> <td>Component Pb</td> <td>B</td> <td>C</td> </tr> <tr> <td>Pr</td> <td>Component Pr</td> <td>R</td> <td></td> </tr> </tbody> </table> <p>(When the [PbPr/TC] switch is set to PbPr)</p> <p>MEMO</p> <ul style="list-style-type: none"> • SYNC signals are added to all channels for RGB signals. • In HDV format, signals are output in analog component format regardless of these settings. 	Terminal	Setting			Y/Pb/Pr	R/G/B	Y/C	Y	Component Y	G	Y	Pb	Component Pb	B	C	Pr	Component Pr	R	
Terminal	Setting																			
	Y/Pb/Pr	R/G/B	Y/C																	
Y	Component Y	G	Y																	
Pb	Component Pb	B	C																	
Pr	Component Pr	R																		
SET UP	<p>Selects whether to add a setup signal to the video signal output from the video signal output connector. In DV format, a setup signal can be added to COMPONENT output and Y/C output. (When Y/Pb/Pr or Y/C is set for OUTPUT TERM [DV])</p> <p>* You can also select a setup signal in the IEEE1394 signal input mode.</p> <p>0.0% : No setup signal is added. 7.5% : A setup signal is added.</p> <p>Initial settings: U model: 7.5% E model: 0.0%</p> <p>MEMO</p> <ul style="list-style-type: none"> • When recording composite video signals from an external device, set this item according to whether the input signals include a setup signal. See "Recording Composite Video Signals from an External Device" on page 65. • When the FRAME RATE item is set to 50/25, this item is not displayed. 																			
PAGE BACK	When the cursor is in this position, press the SHUTTER dial to the VIDEO FORMAT[1/2] menu screen.																			

CAMERA OPERATION Menu Screen

The CAMERA OPERATION menu screen is only displayed in the Camera mode.

Item	Function/Setting (bold characters indicate initial settings)
AE LEVEL ^{*1}	For adjusting the image level when using auto iris, "ALC" or "EEI". Increase value : Increases level. Decrease value : Decreases level. [Settings: -3, -2 - NORMAL (0) - 2, 3]
ALC MAX	Sets the maximum "ALC" value to automatically change the signal intensity level depending on the brightness. [Setting: 6 dB, 12 dB, 18 dB]
PRESET TEMP.	Sets the basic color temperature when the [WHT.BAL] white balance selector switch ⑬ on page 15 is in the PRST (PRESET) position. 3200K : Sets the basic color temperature to 3200K. (Use for light sources with a low color temperature, such as halogen lamps.) 5600K : Sets the basic color temperature to 5600K. (Use for light sources with a high color temperature, such as sunlight.) MEMO This item does not function when the FAW item on the SWITCH MODE menu screen is set to "PRESET".
SMOOTH TRANS ^{*1}	Smoothens the transition when the [GAIN] switch ⑫ on page 15, or [WHT.BAL] switch ⑬ on page 15 is switched over and achieves gradual change in place of sudden change. However, the smooth transition function does not function when switching the [GAIN] switch set in ALC, FULL AUTO ON. OFF : Deactivates the smooth transition function. ON : Activates the smooth transition function.
BARS ^{*1}	Sets whether or not color bars are output. (This is fixed at "OFF" when in FULL AUTO mode) OFF : Color bars are not output. ON : Color bars are output.
PAGE BACK	The TOP MENU returns when the SHUTTER dial is pressed with the cursor at this position.

^{*1} REMOTE appears as the setting value of this item when the remote control unit is connected.

CAMERA PROCESS[1/2]

Menu Screen

The CAMERA PROCESS menu screen consists of two screens. (1/2 screen, 2/2 screen)

The CAMERA PROCESS menu screen is only displayed in camera mode.

Item	Function/Setting (bold characters indicate initial settings)
MASTER BLACK ^{*2}	Adjusts the pedestal level (master black) that serves as the reference black. Increase the number : Raises the pedestal level. Decrease the number : Lowers the pedestal level. [Settings: MIN (-10), -9 - NORMAL (0) - 9, MAX (10)]
DETAIL ^{*2}	Adjusts the contour (detail) sharpness level. Increase the number : Sharpens the contour. Decrease the number : Softens the contour. OFF : Does not function. [Settings: OFF, MIN (-10), -9 - NORMAL (0) - 9, MAX (10)] When this item is set to "OFF", "-----" is displayed for the following menu items and they cannot be selected.
V/H BALANCE ^{*2}	Sets which contours (details) to sharpen, those in the horizontal (H) direction or those in the vertical (V) direction. Increase the number : Sharpens H direction. Decrease the number : Sharpens V direction. [Settings: H-MIN (-5), -4 - NORMAL (0) - 4, H-MAX (5)]
H FREQUENCY ^{*2}	Changes the horizontal contour compensation frequency for the contours (details). Set this as appropriate for the subject. LOW : Enhances low frequency bands. Use this when shooting subjects with large patterns. MIDDLE : Enhances middle frequency bands. HIGH : Enhances high frequency bands. Use this when shooting subjects with small patterns.
V FREQUENCY ^{*1}	Use this when shooting subjects with finely detailed patterns. Changes the vertical contour compensation frequency for the contours (details). Compensates for distortion when outputting progressive video to an interlaced monitor. HIGH : Enhances high frequency bands. LOW : Enhances low frequency bands.
SKIN DETECT ^{*2}	Sets ON/OFF for the skin detail function. OFF : Turns off the skin detail function. ON : Turns on the skin detail function. (Softens detected skin color area details.) ☞ See "Using the Skin Detail Function" on page 104.
LEVEL	Sets the contour compensation level (amount of softening) for the skin detail function. This can only be selected when the SKIN DETECT item is set to ON. -1 : Low contour compensation level (amount of softening) -2 : Medium contour compensation level (amount of softening) -3 : High contour compensation level (amount of softening)
NEXT PAGE	To display the CAMERA PROCESS[2/2] menu screen, move the cursor to this position and press the SHUTTER dial.
PAGE BACK	The TOP MENU returns when the SHUTTER dial is pressed while the cursor is at this position.

*1 When the REC item on the VIDEO FORMAT[1/2] menu is set to "DV-60i" or "DV-50i", "-----" is displayed and this cannot be selected.

*2 REMOTE appears as the setting value of this item when the remote control unit is connected.

CAMERA PROCESS[2/2]

Menu Screen

Item	Function/Setting (bold characters indicate initial settings)
BLACK ^{*1}	<p>Changes the gain in dark areas. Change this depending on the video signal being shot.</p> <p>NORMAL : Normal status</p> <p>STRETCH : Enhances the dark areas of the video so the contrast between light and dark is more visible by stretching the signal only in the dark areas. Set elongation level with STRETCH LEVEL below.</p> <p>COMPRESS : If the video that was shot is bright overall and lacking in contrast, the gain in the dark areas is compressed, which adds contrast. Set compression level with COMPRESS LEVEL below.</p>
STRETCH LEVEL	The amount of stretching increases from LEVEL1→LEVEL2→LEVEL3→LEVEL4→LEVEL5. [Settings: LEVEL1, LEVEL2, LEVEL3 , LEVEL4, LEVEL5]
COMPRESS LEVEL	The amount of compression increases from LEVEL1→LEVEL2→LEVEL3→LEVEL4→LEVEL5. [Settings: LEVEL1, LEVEL2, LEVEL3 , LEVEL4, LEVEL5]
WHITE CLIP	<p>Sets the white clipping point on input video signals with a high luminance level.</p> <p>108% : The white clipping point is set at a luminance level of 108%.</p> <p>100% : The white clipping point is set at a luminance level of 100%. If the screen is too white at 108%, set it to 100%.</p>
KNEE ^{*1}	<p>Sets whether to run the "knee" function, which compresses video signals over a certain level to render the tonality in the highlight areas, automatically or manually. Set "MANUAL" when you want to check the bright areas, and adjust the knee point manually.</p> <p>AUTO : Adjusts the knee point automatically, according to the luminance level.</p> <p>MANUAL : You can change the luminance level in the "LEVEL" item.</p>
LEVEL ^{*1}	<p>Sets the start point for knee compression (knee point). Increase the number : Raises the knee point level. Decrease the number : Lowers the knee point level. [Settings: 80%, 85%, 90%, 95%, 100%]</p> <p>MEMO</p> <hr/> <p>When the "KNEE" item is set to "AUTO", "----" is displayed and this cannot be selected.</p>
REVERSE PICTURE	<p>When the lens image is inverted and flipped, set "ROTATE" to record properly.</p> <p>OFF : No inversion.</p> <p>ROTATE : Invert lens image.</p> <p>MEMO</p> <hr/> <p>When the REVERSE PICTURE item is set to ROTATE, skin detail function is available but the detection area is not displayed in the viewfinder or LCD screen.</p>
DNR	<p>Selects whether or not to set the noise reduction.</p> <p>The DNR (Digital Noise Reduction) function is applied to the tape recording signal, HD component output signal, and the IEEE1394 output signal in CAMERA mode.</p> <p>When camcorder's picture is noisy, because of low light conditions, you can improve picture's S/N by turning DNR on.</p> <p>OFF : Noise reduction is not performed.</p> <p>ON : Sets noise reduction.</p> <p>MEMO</p> <hr/> <ul style="list-style-type: none"> • DNR is not applied in VTR mode, AUX IN mode or during playback. • DNR is not applied to composite output signals in CAMERA mode. • When the DNR is set to ON, the camcorder's S/N ratio becomes better but the "blurring of moving objects" will increase.
ADVANCED PROCESS..	<p>Calls up the ADVANCED PROCESS menu screen.</p> <p> See "ADVANCED PROCESS Menu Screen" on page 83.</p>
PAGE BACK	When the cursor is in this position, press the SHUTTER dial to return to the CAMERA PROCESS[1/2] menu screen.

^{*1} REMOTE appears as the setting value of this item when the remote control unit is connected.

ADVANCED PROCESS

Menu Screen

Item	Function/Setting (bold characters indicate initial settings)
CINEMA	OFF : Turns the function OFF. ON : Sets the gamma characteristics and color matrix close to the characteristics of a movie screen. (The monitor image is movie-quality. This setting is not intended for film output.) MEMO When this item is set to "ON", "[CINE]" is displayed for COLOR MATRIX and GAMMA items and cannot be selected.
COLOR MATRIX	Sets the color matrix. OFF : Turns the function OFF. STANDARD : Sets a normal color matrix. CINEMA : Sets a color matrix close to the characteristics of a movie screen.
ADJUST..	When "STANDARD" or "CINEMA" is set for the COLOR MATRIX item, a color matrix can be set individually. Press the SHUTTER dial to call up the COLOR MATRIX ADJUST menu screen. See "COLOR MATRIX ADJUST Menu Screen" on page 84.
GAMMA	Adjusts the gamma curve to determine how black is rendered. OFF : No gamma curve correction. STANDARD : Sets a normal gamma curve. CINEMA : Sets to appear movie-like when viewing on a TV screen. FILM OUT : Sets to a setting for recording onto film. MEMO When this item is set to "OFF", "----" is displayed for the LEVEL item and it cannot be selected.
LEVEL	When "STANDARD", "CINEMA", or "FILM OUT" is set for the GAMMA item, a gamma curve can be set individually. Increase the number : Enhances the tonality of the black. However, the tonality in the bright areas deteriorates. Decrease the number : Enhances the tonality in the bright areas. However, the tonality in the black areas deteriorates. [Settings: MIN (-5), -4 - NORMAL (0) - 4, MAX (5)]
COLOR GAIN	Adjusts the video signal color level. OFF : Sets the video to black and white. Increase the number : Makes the colors more dense. Decrease the number : Makes the colors less dense. [Settings: OFF, MIN (-10), -9 - NORMAL (0) - 9, MAX (10)]
WHITE BALANCE..	When the cursor is in this position and you press the SHUTTER dial once, the screen switches to the WHITE BALANCE menu screen.
SKIN COLOR ADJUST..	When the cursor is in this position and you press the SHUTTER dial once, the screen switches to the SKIN COLOR ADJUST screen.
PAGE BACK	When the cursor is in this position, press the SHUTTER dial to return to the CAMERA PROCESS[2/2] menu screen.

COLOR MATRIX ADJUST Menu Screen

Item	Function/Setting (bold characters indicate initial settings)
R GAIN	For manually adjusting the shading of the R axis of the color matrix (red and cyan). Increase the number : Enhances red and cyan. Decrease the number : Reduces red and cyan. [Settings: MIN (-5), -4 - NORMAL (0) - 4, MAX (5)]
R ROTATION	For manually adjusting the color phase of the R axis of the color matrix (red and cyan). Increase the number : Increases yellowishness of red color and bluishness of cyan color. Decrease the number : Increases bluishness of red color and greenishness of cyan color. [Settings: MIN (-5), -4 - NORMAL (0) - 4, MAX (5)]
G GAIN	For manually adjusting the shading of the G axis of the color matrix (green and magenta). Increase the number : Enhances green and magenta. Decrease the number : Reduces green and magenta. [Settings: MIN (-5), -4 - NORMAL (0) - 4, MAX (5)]
G ROTATION	For manually adjusting the color phase of the G axis of the color matrix (green and magenta). Increase the number : Increases bluishness of green color and reddishness of magenta color. Decrease the number : Increases yellowishness of green color and bluishness of magenta color. [Settings: MIN (-5), -4 - NORMAL (0) - 4, MAX (5)]
B GAIN	For manually adjusting the shading of the B axis of the color matrix (blue and yellow). Increase the number : Enhances blue and yellow. Decrease the number : Reduces blue and yellow. [Settings: MIN (-5), -4 - NORMAL (0) - 4, MAX (5)]
B ROTATION	For manually adjusting the color phase of the B axis of the color matrix (blue and yellow). Increase the number : Increases reddishness of blue color and greenishness of yellow color. Decrease the number : Increases greenishness of blue color and reddishness of yellow color. [Settings: MIN (-5), -4 - NORMAL (0) - 4, MAX (5)]
PAGE BACK	Press the SHUTTER dial to return to the ADVANCED PROCESS screen when cursor is at this position.

SKIN COLOR ADJUST Menu Screen

When you enter the SKIN COLOR ADJUST screen, the areas where the skin detail function is applied are displayed in color, and other areas are displayed in black and white.

Item	Function/Setting (bold characters indicate initial settings)
SKIN COLOR DET.	Sets the color used by the skin detail function. STOP : Stops loading the color used by the skin detail function. EXECUTE : Loads the color used by the skin detail function. ☞ See "How to Use Skin Detail" on page 103.
SKIN COLOR RANGE	Adjusts the range of skin colors to which the skin detail function is applied. Adjust as you check the color range. Increase the number : Widens the range. Decrease the number : Narrows the range. [Settings: NARROW (-10), -9 - NORMAL (0) - 9, WIDE (10)] MEMO When the COLOR GAIN item is "OFF" on the ADVANCED PROCESS menu screen, only the areas where the skin detail function is running are displayed using skin colors.
PAGE BACK	When the cursor is in this position, press the SHUTTER dial to return to the ADVANCED PROCESS menu screen.

WHITE BALANCE Menu Screen

Item	Function/Setting (bold characters indicate initial settings)
WHITE PAINT<R>*1	<p>Adjusts the R (red) component when in AWB (Auto White Balance) mode. Increase the number : Strengthens the red. Decrease the number : Weakens the red. [Settings: MIN (-32), -31 - NORMAL (0) - 30, MAX (31)]</p> <p>MEMO</p> <ul style="list-style-type: none"> You can select this when A or B is set for the [WHT.BAL] switch 13 on the right panel of this device. See page 15. Settings can be made for A and B individually. (When "PRESET" is set, "----" is displayed and this cannot be selected.) When you press the AWB (Auto White Balance) button and readjust the white balance, WHITE PAINT R becomes "NORMAL".
WHITE PAINT*1	<p>Adjusts the B (blue) component when in AWB (Auto White Balance) mode. Increase the number : Strengthens the blue. Decrease the number : Weakens the blue. [Settings: MIN (-32), -31 - NORMAL (0) - 30, MAX (31)]</p> <p>MEMO</p> <ul style="list-style-type: none"> You can select this when A or B is set for the [WHT.BAL] switch 13 on the right panel of this device. See page 15. Settings can be made for A and B individually. (When "PRESET" is set, "----" is displayed and this cannot be selected.) When you press the AWB (Auto White Balance) button and readjust the white balance, WHITE PAINT becomes "NORMAL".
SHADING	<p>Adjusts white shading. PRESET : No white shading adjustment. MANUAL : Enables white shading adjustment. See "White Shading Adjustment" on page 53.</p> <p>MEMO</p> <p>When the SHADING item is set to PRESET, the LEVEL R, LEVEL G, and LEVEL B items cannot be selected.</p>
LEVEL R	<p>When the SHADING item is set to MANUAL, adjusts the reds of white shading. Increase the number : Red at the bottom of the screen is suppressed and the top is enhanced. Decrease the number : Red at the top of the screen is suppressed and the bottom is enhanced. [Settings: MIN, -127 to -1, NORMAL, 1 to 126, MAX]</p>
LEVEL G	<p>When the SHADING item is set to MANUAL, adjusts the greens of white shading. Increase the number : Green at the bottom of the screen is suppressed and the top is enhanced. Decrease the number : Green at the top of the screen is suppressed and the bottom is enhanced. [Settings: MIN, -127 to -1, NORMAL, 1 to 126, MAX]</p>
LEVEL B	<p>When the SHADING item is set to MANUAL, adjusts the blues of white shading. Increase the number : Blue at the bottom of the screen is suppressed and the top is enhanced. Decrease the number : Blue at the top of the screen is suppressed and the bottom is enhanced. [Settings: MIN, -127 to -1, NORMAL, 1 to 126, MAX]</p>
PAGE BACK	When the cursor is in this position, press the SHUTTER dial to return to ADVANCED PROCESS menu screen.

*1 REMOTE appears as the setting value of this item when the remote control unit is connected.

SWITCH MODE Menu Screen

The SWITCH MODE menu screen is only displayed in camera mode.

Item	Function/Setting (bold characters indicate initial settings)														
SHUTTER	<p>Sets the fixed value (STEP) for values that can change using the SHUTTER dial on the right panel or the VARIABLE used when shooting computer monitors.</p> <p>STEP : Switches the shutter speed using fixed values. VARIABLE : Set when shooting a computer monitor, etc.</p> <p>You can set the following using the REC item on the VIDEO FORMAT menu screen. (This is fixed at EEI when in FULL AUTO mode.)</p> <table border="1"> <thead> <tr> <th>REC Item</th> <th>Setting for STEP</th> <th>Setting for VARIABLE</th> </tr> </thead> <tbody> <tr> <td>DV-60i HDV-HD60P HDV-HD30P</td> <td>1/7.5, 1/15, 1/30, 1/60, 1/100, 1/250, 1/500, 1/1000, 1/2000, 1/4000, 1/10000</td> <td>1/30.03 - 1/10489.5</td> </tr> <tr> <td>DV-50i HDV-HD50P HDV-HD25P DV-25P</td> <td>1/6.25, 1/12.5, 1/25, 1/50, 1/120, 1/250, 1/500, 1/1000, 1/2000, 1/4000, 1/10000</td> <td>1/25.04 - 1/10489.5</td> </tr> <tr> <td>DV-24P DV-24PA HDV-HD24P</td> <td>1/6, 1/12, 1/24, 1/48, 1/60, 1/100, 1/250, 1/500, 1/1000, 1/2000, 1/4000, 1/10000</td> <td>1/24.01 - 1/10489.5</td> </tr> </tbody> </table>	REC Item	Setting for STEP	Setting for VARIABLE	DV-60i HDV-HD60P HDV-HD30P	1/7.5, 1/15, 1/30, 1/60 , 1/100, 1/250, 1/500, 1/1000, 1/2000, 1/4000, 1/10000	1/30.03 - 1/10489.5	DV-50i HDV-HD50P HDV-HD25P DV-25P	1/6.25, 1/12.5, 1/25, 1/50 , 1/120, 1/250, 1/500, 1/1000, 1/2000, 1/4000, 1/10000	1/25.04 - 1/10489.5	DV-24P DV-24PA HDV-HD24P	1/6, 1/12, 1/24, 1/48 , 1/60, 1/100, 1/250, 1/500, 1/1000, 1/2000, 1/4000, 1/10000	1/24.01 - 1/10489.5		
REC Item	Setting for STEP	Setting for VARIABLE													
DV-60i HDV-HD60P HDV-HD30P	1/7.5, 1/15, 1/30, 1/60 , 1/100, 1/250, 1/500, 1/1000, 1/2000, 1/4000, 1/10000	1/30.03 - 1/10489.5													
DV-50i HDV-HD50P HDV-HD25P DV-25P	1/6.25, 1/12.5, 1/25, 1/50 , 1/120, 1/250, 1/500, 1/1000, 1/2000, 1/4000, 1/10000	1/25.04 - 1/10489.5													
DV-24P DV-24PA HDV-HD24P	1/6, 1/12, 1/24, 1/48 , 1/60, 1/100, 1/250, 1/500, 1/1000, 1/2000, 1/4000, 1/10000	1/24.01 - 1/10489.5													
FAW	<p>Sets the positions to assign the FAW (Full Auto White Balance) function to the [WHT.BAL] white balance selector switch ⑬ on page 15. (Fixed at FAW when in FULL AUTO mode)</p> <p>NONE : The FAW function is not assigned. A : Assigns FAW to the A position. B : Assigns FAW to the B position. PRESET : Assigns FAW to the PRESET position.</p>														
GAIN L GAIN M GAIN H	<p>Sets the gain value for each position on the [GAIN] sensitivity selector switch ⑫ on page 15. [Setting: 0dB, 3dB, 6dB, 9dB, 12dB, 15dB, 18dB, ALC] (Fixed at ALC in FULL AUTO mode)</p> <p>Initial values: L: 0dB, M: 9dB, H: 18dB</p>														
USER1 USER2 USER3	<p>You can assign one of the following menu functions to the [USER1/2/3] buttons ⑧ on page 14 to each button. Set according to the shooting conditions. This is only valid in CAMERA mode. This does not function in VTR mode.</p> <table border="1"> <thead> <tr> <th>Setting</th> <th>Description</th> </tr> </thead> <tbody> <tr> <td>NONE</td> <td>Does not function.</td> </tr> <tr> <td>BARS PRESET TEMP.</td> <td>Assigns "BARS" item functions in the CAMERA OPERATION menu screen. Assigns "PRESET TEMP." item functions in the CAMERA OPERATION menu screen. ☞ See "CAMERA OPERATION Menu Screen" on page 80.</td> </tr> <tr> <td>B.STRETCH1 B.STRETCH2 B.STRETCH3 B.STRETCH4 B.STRETCH5 B.COMPRESS1 B.COMPRESS2 B.COMPRESS3 B.COMPRESS4 B.COMPRESS5</td> <td>Assigns "BLACK" item functions in the CAMERA PROCESS[1/2] menu screen. ☞ See "CAMERA PROCESS[1/2] Menu Screen" on page 81.</td> </tr> <tr> <td>AE LEVEL+ AE LEVEL-</td> <td>Assigns "AE LEVEL" item functions in the CAMERA OPERATION menu screen. MEMO Cannot assign to the USER3 button. If you assign these menu functions, assign AE LEVEL+ to the USER1 button, AE LEVEL- to the USER2 button.</td> </tr> <tr> <td>RET</td> <td>Assigns the normal RET button function.</td> </tr> <tr> <td>LOAD FILE</td> <td>Assigns the function to jump to in the LOAD FILE menu. ☞ See "FILE MANAGE Menu Screen" on page 100.</td> </tr> </tbody> </table>	Setting	Description	NONE	Does not function.	BARS PRESET TEMP.	Assigns "BARS" item functions in the CAMERA OPERATION menu screen. Assigns "PRESET TEMP." item functions in the CAMERA OPERATION menu screen. ☞ See "CAMERA OPERATION Menu Screen" on page 80.	B.STRETCH1 B.STRETCH2 B.STRETCH3 B.STRETCH4 B.STRETCH5 B.COMPRESS1 B.COMPRESS2 B.COMPRESS3 B.COMPRESS4 B.COMPRESS5	Assigns "BLACK" item functions in the CAMERA PROCESS[1/2] menu screen. ☞ See "CAMERA PROCESS[1/2] Menu Screen" on page 81.	AE LEVEL+ AE LEVEL-	Assigns "AE LEVEL" item functions in the CAMERA OPERATION menu screen. MEMO Cannot assign to the USER3 button. If you assign these menu functions, assign AE LEVEL+ to the USER1 button, AE LEVEL- to the USER2 button.	RET	Assigns the normal RET button function.	LOAD FILE	Assigns the function to jump to in the LOAD FILE menu. ☞ See "FILE MANAGE Menu Screen" on page 100.
Setting	Description														
NONE	Does not function.														
BARS PRESET TEMP.	Assigns "BARS" item functions in the CAMERA OPERATION menu screen. Assigns "PRESET TEMP." item functions in the CAMERA OPERATION menu screen. ☞ See "CAMERA OPERATION Menu Screen" on page 80.														
B.STRETCH1 B.STRETCH2 B.STRETCH3 B.STRETCH4 B.STRETCH5 B.COMPRESS1 B.COMPRESS2 B.COMPRESS3 B.COMPRESS4 B.COMPRESS5	Assigns "BLACK" item functions in the CAMERA PROCESS[1/2] menu screen. ☞ See "CAMERA PROCESS[1/2] Menu Screen" on page 81.														
AE LEVEL+ AE LEVEL-	Assigns "AE LEVEL" item functions in the CAMERA OPERATION menu screen. MEMO Cannot assign to the USER3 button. If you assign these menu functions, assign AE LEVEL+ to the USER1 button, AE LEVEL- to the USER2 button.														
RET	Assigns the normal RET button function.														
LOAD FILE	Assigns the function to jump to in the LOAD FILE menu. ☞ See "FILE MANAGE Menu Screen" on page 100.														
LENS RET	<p>Sets the lens RET button functions. (This does not function if there is not RET button on the lens you are using.)</p> <p>RET : Functions as a normal RET button. FOCUS ASSIST : Functions as the FOCUS ASSIST button.</p>														
PAGE BACK	When the cursor is in this position, press the SHUTTER dial to return to the TOP MENU screen.														

AUDIO/MIC[1/2] Menu Screen

The AUDIO/MIC menu screen consists of two screens (1/2 screen, 2/2 screen).
In VTR mode, the screen changes to the AUDIO menu screen.

* This is not displayed in VTR mode.

Item	Function/Setting (bold characters indicate initial settings)
TEST TONE	Sets whether to output a test audio signal (1 kHz, -20dBFS or -12dBFS) during color bar output. OFF : A test audio signal is not output. ON : A test audio signal is output.
MIC WIND CUT*	Selects whether to cut the lows (low frequency bands) from the audio input signal. Use this when you want to reduce wind sounds from the microphone. OFF : Low frequencies are not cut. INPUT1 : Only cuts the low frequencies in the audio from the INPUT1 connector. INPUT2 : Only cuts the low frequencies in the audio from the INPUT2 connector. BOTH : Cuts the low frequencies in the audio from both the INPUT1 and INPUT2 terminals.
AUDIO REF.LEVEL	Sets the reference audio level on the tape. (Both CH-1 and CH-2) -20dB : Records with -20 dB as the reference audio level. -12dB : Records with -12 dB as the reference audio level. Set this if you are playing back the recorded tape on an ordinary DV device. * Set this for both playback and recording. * This is unrelated to the audio level via the IEEE1394 signal.
INPUT1 MIC REF.*	Sets the reference audio input level for the INPUT1 connector. (When the [AUDIO INPUT] switch ③ on page 16 is set to MIC or MIC+48) -50dB : Sets the reference audio input level at -50 dB. -60dB : Sets the reference audio input level at -60 dB.
INPUT2 MIC REF.*	Sets the reference audio input level for the INPUT2 connector. (When the [AUDIO INPUT] switch ③ on page 16 is set to MIC or MIC+48) -50dB : Sets the reference audio input level at -50 dB. -60dB : Sets the reference audio input level at -60 dB.
AUDIO MODE*	Selects the audio sampling frequency for recording. (Both CH-1 and CH-2) (When HDV format is set, this is fixed at 48K and "[48K]" is displayed.) 32K : Digitally records with a 12-bit, 32 kHz sampling frequency. 48K : Digitally records with a 16-bit, 48 kHz sampling frequency. * If the DV format is 12-bit, 32 kHz, up to 4 recording track channels are available. Of those, GY-HD250/GY-HD251 records on the CH-1 and CH-2 channels. GY-HD250/GY-HD251 is not capable of dubbing.
AUDIO LIMITER*	Sets whether or not AUDIO LIMITER functions when the [CH-1/CH-2 AUDIO SELECT] switch ② on page 13 is set to MANU. OFF : AUDIO LIMITER is turned off. ON : AUDIO LIMITER is turned on. Recording level is suppressed when excessive audio is input.
NEXT PAGE	To display the AUDIO/MIC[2/2] menu screen, move the cursor to this position and press the SHUTTER dial.
PAGE BACK	When the cursor is in this position, press the SHUTTER dial to return to the TOP MENU screen.

AUDIO/MIC[2/2] Menu Screen

In VTR mode, the screen changes to the AUDIO menu screen.

* This is not displayed in VTR mode.

Item	Function/Setting (bold characters indicate initial settings)
AUDIO MONITOR	Selects whether stereo or mixed audio is output from the PHONES jack when the MONITOR SELECT switch is set to BOTH. STEREO : Stereo audio (CH-1 audio is output to L and CH-2 audio is output to R) * Outputs only the CH-1 audio from the monitor speaker. MIX : Mixed audio (CH-1 and CH-2 mixed audio is output to L and R)
FAS AUDIO*	Selects the recording level adjusting method for FAS (Full Auto Shooting). (CH-1, CH-2) AUTO : Sets to AUTO. SW SET : Follows settings for the AUDIO SELECT switch. ☞ See "② [CH-1/CH-2 AUDIO SELECT] switch" on page 13. ☞ See "⑰ [FULL AUTO] switch" on page 19.
SEARCH AUDIO [DV]	Selects whether to output audio when searching a tape recorded in DV format. (This also includes slow playback.) ON : Audio is output. OFF : Audio is not output.
PB AUDIO CH [DV]	Selects which channel audio to output when playing back a DV tape with the audio signal recorded in 4 channels. (Can only be set in VTR mode) CH1/2 : Outputs the CH-1 and CH-2 channel audio. GY-HD250/GY-HD251 records the audio in CH-1 and CH-2 while shooting. MIX : Outputs all 4 channels of audio at the same time. CH3/4 : Outputs the CH-3 and CH-4 channel audio. MEMO GY-HD250/GY-HD251 does not have a function for dubbing to the CH-3 and CH-4 channels.
PAGE BACK	When the cursor is in this position, press the SHUTTER dial to the AUDIO/MIC[1/2] menu screen.

LCD/VF[1/4] Menu Screen

The LCD/VF menu screen consists of four screens. (1/4 screen, 2/4 screen, 3/4 screen, 4/4 screen)

The LCD/VF[1/4] menu screen can only be set in camera mode.

In VTR mode, this screen consists of two screens. (1/2 screen, 2/2 screen)

Item	Function/Setting (bold characters indicate initial settings)
ZEBRA	Switches the luminance level of the subject sections where the zebra pattern is displayed. 60-70% : Zebra pattern is displayed in sections with luminance levels between 60% and 70%. 70-80% : Zebra pattern is displayed in sections with luminance levels between 70% and 80%. 85-95% : Zebra pattern is displayed in sections with luminance levels between 85% and 95%. OVER95% : Zebra pattern is displayed in sections with luminance levels over 95%. OVER100% : Zebra pattern is displayed in sections with luminance levels over 100%.
F. NO/IRIS IND.	Selects whether or not the F-number of the lens iris/iris level mark is displayed in the status display on the LCD monitor or in the viewfinder. (STATUS 1 screen) OFF : F-number and iris level mark is not displayed. F.NO : F-number is displayed. F.NO+IND. : F-number and iris level mark is displayed.
FILTER	Selects whether or not the FILTER position of this device is displayed in the status display on the LCD monitor or in the viewfinder. (STATUS 1 screen) OFF : FILTER position is not displayed. ON : FILTER position is displayed.
SAFETY ZONE ^{*1}	Selects whether or not the safety zone is shown on the LCD monitor or in the viewfinder together with the form of the safety zone indication. OFF : Not displayed. 4:3 : 4:3 zone is displayed. 14:9 : 14:9 zone is displayed. 16:9 : 16:9 zone is displayed. 16:9+4:3 : 16:9 zone and 4:3 zone are display mixed. (This cannot be selected when DV format is set.) 2.35:1 CE : Displays 2.35:1 zone in the middle of the screen. (Only in HDV format or 24P or 25P mode) 2.35:1 CH : Displays 2.35:1 zone at the top of the screen. (Only in HDV format or 24P or 25P mode)
CENTER MARK ^{*1}	Sets whether or not a center mark is displayed when the safety zone is displayed. ON : Center mark is displayed. OFF : Center mark is not displayed. MEMO <hr/> When the SAFETY ZONE item is set to OFF, "- -" is indicated and this item cannot be selected.
FOCUS ASSIST	Sets the FOCUS ASSIST function. Press the [FOCUS ASSIST] button on page 14 (⑥) or page 18 (⑦) to operate the FOCUS ASSIST function. NORMAL : Only the [FOCUS ASSIST] function operates. (The focus area becomes blue, red or green, making it easier to focus.) ACCU-FOCUS : The FOCUS ASSIST function and ACCU-FOCUS (forced focus) function operates. This makes the depth of field shallower, making it easier to focus. ACCU FOCUS automatically turns OFF after approximately 10 seconds.
COLOR	Sets the display color for focusing when running the FOCUS ASSIST function. BLUE : Displays the area of focus in blue. RED : Displays the area of focus in red. GREEN : Displays the area of focus in green.
LEVEL	Sets the display range of the focal area when the FOCUS ASSIST function is in use. LOW : Displays the focal area narrower than MIDDLE. MIDDLE : Displays the focal area in normal setting. HIGH : Displays the focal area wider than MIDDLE.
NEXT PAGE	When you display the LCD/VF[2/4] menu screen, move the cursor to this position and press the SHUTTER dial.
PAGE BACK	When the cursor is in this position, press the SHUTTER dial to return to the TOP MENU screen.

*1 SAFETY ZONE and CENTER MARK will not be displayed when this device is in VTR mode (PLAY, STL, FWD, REV).

LCD/VF[2/4] Menu Screen

The LCD/VF[2/4] menu screen can only be set in camera mode.

Item	Function/Setting (bold characters indicate initial settings)
LCD MIRROR MODE	<p>Sets the image display method when the LCD monitor is in counterview position.</p> <p>NORMAL : Image is displayed without inverting. MIRROR : Inverted image is displayed.</p> <ul style="list-style-type: none"> • NORMAL/MIRROR is set when the SHUTTER dial is pressed. <p>MEMO</p> <hr/> <p>MIRROR setting is disabled when color bar is displayed or status is in magnified size.</p> <p>☞ See "Outputting Color Bars" on page 105. ☞ See "Magnified Status Indications on the LCD Monitor" on page 29.</p>
NEXT PAGE	When you display the LCD/VF[3/4] menu screen, move the cursor to this position and press the SHUTTER dial.
PAGE BACK	When the cursor is in this position, press the SHUTTER dial to return to the LCD/VF[1/4] menu screen.

LCD/VF[3/4] Menu Screen

[1/2] screen is displayed in the VTR mode.

Item	Function/Setting (bold characters indicate initial settings)
VIDEO FORMAT	<p>Selects whether to display the video format in the status display on the LCD monitor or the viewfinder. (Camera mode: STATUS 1 screen, VTR mode: STATUS screen)</p> <p>ON : Displays the video format. OFF : Does not display the video format.</p> <p>In camera mode : Displays the video format set in the REC item on the VIDEO FORMAT menu screen. In VTR mode : Displays the video format recorded on the playback tape or the video format input from the IEEE1394 connector.</p>
TAPE REMAIN	<p>Selects whether or not the remaining tape time (minutes) is shown in the status display on the LCD monitor or in the viewfinder. (Camera mode: STATUS 1 screen, VTR mode: STATUS screen)</p> <p>ON : Displayed. OFF : Not displayed.</p>
TC/UB	<p>Selects whether or not the time code or user's bits data should be shown in the status display on the LCD monitor or in the viewfinder. (Camera mode: STATUS 1 screen, VTR mode: STATUS screen)</p> <p>ON : Displayed. OFF : Not displayed.</p> <p>* Whether the time code or user's bits data is shown is selected with the TC DISPLAY switch.</p>
AUDIO	<p>Selects whether the audio level meters should be shown in the status display on the LCD monitor and the viewfinder screen. (Camera mode: STATUS 1 screen, VTR mode: STATUS screen)</p> <p>ON : Displayed. OFF : Not displayed.</p>
BATTERY INFO.	<p>For setting the status display method when loading the Anton-Bauer Battery. The status will be displayed on the LCD screen and the viewfinder screen. (In camera mode, only displayed when in STATUS 1 screen.)</p> <p>VOLTAGE : Indicates battery voltage in 0.1 V steps [V] CAPA% : Remaining battery is shown in percentage [%] TIME : Remaining battery is shown in minutes [min]</p> <ul style="list-style-type: none"> • VOLTAGE and CAPA% can be selected when using an IDX Endura battery. When TIME is set, VOLTAGE is displayed. <p>MEMO</p> <hr/> <ul style="list-style-type: none"> • When TIME or CAPA% is selected, the battery indicator displayed before the value changes depending on the remaining battery level. □: 12% or less ▣: 12% to less than 50% ▤: 50% or more • When remaining battery level becomes less than 12%, the display changes to "□ RES". • When CALIBRATION is required from the battery, the display switches between TIME (CAPA%) display (30 seconds) and "□ CAL" display (2 seconds) repeatedly. • For CALIBRATION, refer to the instruction manual of Anton-Bauer Battery. • Please use the remaining battery level and remaining time as a reference for shooting duration.
SHUTTER DISP.	<p>Sets the shutter display method to seconds or angle.</p> <p>SEC : Seconds DEG : Degrees</p> <p>MEMO</p> <hr/> <p>This item is available when REC on the VIDEO FORMAT[1/2] menu screen is set to HDV-HD24P, DV-24P, DV-24PA, HDV-HD25P, or DV-25P. Shutter display method is fixed to SEC for other settings. ("[SEC]" is displayed.)</p>
NEXT PAGE	<p>Camera mode: To display the LCD/VF[4/4] menu screen, move the cursor to this position and press the SHUTTER dial. VTR mode: To display the LCD/VF[2/2] menu screen, move the cursor to this position and press the SHUTTER dial.</p>
PAGE BACK	<p>Camera mode: When the cursor is in this position, press the SHUTTER dial to return to the LCD/VF[2/4] menu screen. VTR mode: When the cursor is in this position, press the SHUTTER dial to return to the TOP MENU screen.</p>

LCD/VF[4/4] Menu Screen

[2/2] screen is displayed in the VTR mode.

* This is not displayed in VTR mode.

Item	Function/Setting (bold characters indicate initial settings)
LCD+VF	Selects the LCD monitor and viewfinder display switching method. ON : Viewfinder always displayed the image. OFF : Turns off the viewfinder display when the LCD monitor is opened. MEMO When this item is set to ON, the contents displayed on the LCD monitor can be changed with the DISPLAY button. See page 29.
LCD CONTRAST	Adjusts the contrast of the LCD. [Settings: MIN (-5), -4 - NORMAL (0) - 4, MAX (5)]
VF CONTRAST	Adjusts the contrast of the viewfinder. [Settings: MIN (-5), -4 - NORMAL (0) - 4, MAX (5)]
BLACK & WHITE*	Selects the LCD monitor and viewfinder display style. COLOR : Displays the image in color. B&W : Displays the image in black and white. MEMO Characters are always displayed in color.
VF SIGNAL	Sets the image format output from the Viewfinder connector ① on page 16. RGB : RGB signals Y : Y signals (Brilliance signals) COMPONENT : Component signals COMPOSITE : Composite signals MEMO <ul style="list-style-type: none"> • Set this to RGB when using the supplied viewfinder. The supplied viewfinder will not function properly when set to another setting. • When this is set to Y or COMPOSITE in the HDV mode, images are not output from the [Y/Pb/Pr] terminal. • When the VF-P400 viewfinder (sold separately) is connected to the Viewfinder connector, set this to Y to view HDV format images with the VF-P400. ■ When this is set to COMPONENT or COMPOSITE, the following occurs. <ul style="list-style-type: none"> • FOCUS ASSIST and SKIN AREA are not displayed. ■ When this is set to COMPONENT, the following restrictions are applied in HDV mode. <ul style="list-style-type: none"> • Set output of characters from the viewfinder terminal with ON/OFF in ANALOG OUT CHAR. item on the OTHERS[1/2] menu screen. • Also set ZEBRA output from the viewfinder terminal with ON/OFF in ANALOG OUT CHAR. Item (When the ZEBRA switch is ON). When ZEBRA is set to ON, ZEBRA is also displayed for COMPONENT output from the [Y/Pb/Pr] terminal.
PAGE BACK	Camera mode: When the cursor is in this position, press the SHUTTER dial to return to the LCD/VF[3/4] menu screen. VTR mode: When the cursor is in this position, press the SHUTTER dial to return to the LCD/VF[1/2] menu screen.

TC/UB/CLOCK Menu Screen

Time codes (TC) and user's bits (UB) can be set on this screen. Date and time is set on the TIME/DATE screen that can be reached from this screen.

Item	Function/Setting (bold characters indicate initial settings)
TCG SOURCE	<p>Selects the source of the time code generator.</p> <p>INTERNAL : Uses the built-in time code generator</p> <p>EXTERNAL : Uses the time code generator connected to the [TC IN] terminal</p> <p>MEMO</p> <hr/> <ul style="list-style-type: none"> • TC PRESET and UB PRESET are not available when set to EXTERNAL. • HEADER REC is disabled when set to EXTERNAL. • When this is set to EXTERNAL, the setting for TC DUPLI. is invalidated.
TC PRESET	<p>To preset the time code, align the cursor with this position and then press the SHUTTER dial.</p> <p>EXECUTE : The set time code is confirmed.</p> <p>CANCEL : The set time code is cancelled.</p> <p>ZERO PRESET : Resets all time codes to "0".</p>
UB PRESET	<p>To preset the user's bit data, align the cursor with this position and then press the SHUTTER dial.</p> <p>EXECUTE : The set user's bit data are confirmed.</p> <p>CANCEL : The set user's bit data are cancelled.</p> <p>ZERO PRESET : Resets all user's bits data to "0".</p> <p>MEMO</p> <hr/> <p>When the "UB REC" item is set to "OFF", "-----" is displayed and this cannot be selected.</p>
DROP FRAME *1	<p>Selects whether the time code generator framing mode is drop-frame or non-drop-frame.</p> <p>DROP : Internal time code generator works in drop-frame mode. Set this when the recorded time is important.</p> <p>NON DROP : Internal time code generator works in non-drop-frame mode. Set this when the number of frames is important.</p>
UB REC *2	<p>To select whether or not user's bit data should be recorded.</p> <p>To select whether the user's bits should be displayed during playback of a tape with recorded user's bits data.</p> <p>ON : User's bits are recorded during recording. User's bits are displayed during playback.</p> <p>OFF : User's bits are not recorded during recording. User's bits are not displayed during playback.</p>
TC DUPLI.	<p>Sets how to record the time code (TC) and user's bits (UB) during IEEE1394 input of HDV/DV format.</p> <p>OFF : Records the TC/UB set in this device.</p> <p>ON : Records the TC/UB of the IEEE1394 input.</p> <p>MEMO</p> <hr/> <ul style="list-style-type: none"> • This is validated when TCG SOURCE is set to INTERNAL. • In HDV format, the UB set in this device is recorded regardless of the setting.
HEADER REC..	<p>To make settings related to the HEADER REC function, align the cursor with this position, and then press the SHUTTER dial.</p> <p>☞ See "HEADER REC Menu Screen" on page 94.</p>
TIME/DATE..	<p>To make settings related to the date and time, align the cursor with this position and then press the SHUTTER dial.</p> <p>☞ See "TIME/DATE Menu Screen" on page 95.</p>
PAGE BACK	<p>When the cursor is in this position, press the SHUTTER dial to return to the TOP MENU screen.</p>

*1 This can be displayed and selected when 60/30 is set for the FRAME RATE item on the VIDEO FORMAT menu screen. (When 24 is set, this is fixed at "NON DROP" and "[NON DROP]" is displayed.)

*2 This can be displayed and selected when 50/25 is set for the FRAME RATE item on the VIDEO FORMAT menu screen.

HEADER REC Menu Screen

The HEADER REC menu screen is used for settings related to the HEADER REC function.  See page 60.



Item	Function/Setting (bold characters indicate initial settings)
START KEY	Sets whether the HEADER REC operation should be executed when the REC/VTR trigger button is pressed while the STOP button is pressed. DISABLE : HEADER REC operation is not executed. STOP+REC : HEADER REC operation is executed.
TC DATA	Sets the time code value for the point when the Record-Standby mode is engaged following completion of HEADER REC. EXECUTE : Confirms the set time code. ZERO PRESET : Resets all time codes to "0". CANCEL : Clears the set time code. The frame mode is set depending on the setting in the DROP FRAME item on the TC/UB/CLOCK menu screen. * The time code value at the point when the Record-Standby mode is engaged may differ some frames from the value set for this item.
UB DATA	Sets the user's bits of the HEADER REC section. EXECUTE : Confirms the set user's bits. ZERO PRESET : Resets all user's bits data to "0". CANCEL : Clears the set user's bits. MEMO <hr/> <ul style="list-style-type: none"> • The user's bits for the normal recording section are set on the TC/UB/CLOCK menu screen. • When the "UB REC" item is set to "OFF", "-----" is displayed and this cannot be selected.
BARS TIME	Sets the duration (seconds) in which the color bar signal and test tone (1 kHz) is recorded during HEADER REC. (1-sec steps) [Settings: 0SEC - 30SEC - 99SEC]
BLACK TIME	Sets the duration (seconds) in which the black signal is recorded during HEADER REC. (1-sec steps) [Settings: 0SEC - 30SEC - 99SEC]
PAGE BACK	The TC/UB/CLOCK menu screen returns when the SHUTTER dial is pressed.

TIME/DATE Menu Screen

Item	Function/Setting (bold characters indicate initial settings)
DISPLAY	Sets whether the date and time are shown in the status display on the LCD monitor or in the viewfinder. OFF : Not displayed. ON : Displayed. When a tape with time and date not recorded is played back, there will be no display of time and date even when this item is set to ON.
DISPLAY MODE	In the Camera mode, the date and time are displayed in accordance with the following settings. The date and time recorded on a tape are displayed in accordance with the following settings. BARS+CAM : Date and time are always displayed. BARS : Date and time are displayed when the color bars are output. CAM : Date and time are displayed when the camera images are output. When the DISPLAY item is set to OFF, "--" is indicated and this item cannot be selected.
DISPLAY STYLE	Selects the style for the date and time display. DATE+TIME : Date and time are displayed. DATE : Date only is displayed. TIME : Time only is displayed. When the DISPLAY item is set to OFF, "--" is indicated and this item cannot be selected.
DATE STYLE	Selects the style for the date display. YY/MM/DD : Displayed in the format of year/month/date. MM/DD/YY : Displayed in the format of month/date/year. DD/MM/YY : Displayed in the format of date/month/year. Variation Range: U model: MM/DD/YY E model: DD/MM/YY When the DISPLAY item is set to OFF, "--" is indicated and this item cannot be selected.
TIME STYLE	Selects the style for the time display. 24 HOUR : Displays the time using the 24-hour system. 12 HOUR : Displays the time using the 12-hour system. When the DISPLAY item is set to OFF, "--" is indicated and this item cannot be selected.
SEC DISPLAY	Selects whether to display the seconds in the time display. ON : Seconds are displayed. OFF : Seconds are not displayed. When the DISPLAY item is set to OFF, "--" is indicated and this item cannot be selected.
TIME SHIFT	Sets the clock OFFSET time. (1H steps) Adds time to the built-in clock (time compensation) and displays it. The adjusted time is also recorded on the tape. [Settings: -23H - -1H, OFF , +1H - +23H]
CLOCK ADJUST	To adjust the date and time, align the cursor with this position and then press the SHUTTER dial. The date and time are set on the CLOCK ADJUST screen. ☞ See "Setting the Date and Time" on page 42.
PAGE BACK	The TC/UB/CLOCK menu returns when the SHUTTER dial is pressed while the cursor is at this position.

OTHERS[1/2] Menu Screen

The OTHERS menu screen consists of two screens (1/2 screen, 2/2 screen)

Item	Function/Setting (bold characters indicate initial settings)
ANALOG OUT CHAR.	<p>Sets whether or not to display characters such as status and menus on the screen for the [Y/Pb/Pr] and [VIDEO OUT] terminals.</p> <p>ON : On-screen display. OFF : No on-screen display.</p> <p>MEMO</p> <p>When ANALOG OUT CHAR. item is set to ON, the content displayed on the viewfinder is also displayed in the video from the video output terminal. During VTR recording, the mode is displayed in red on the viewfinder. However, color is not applied for the following video outputs.</p> <ul style="list-style-type: none"> • Component output of recording or playback in DV format • Composite output
SDI OUT CHAR.	<p>Sets whether or not to display characters such as status and menus on the screen for the [HD/SD SDI] terminal.</p> <p>ON : On-screen display. OFF : No on-screen display.</p>
LONG PAUSE TIME	<p>Selects the time (minutes) before the tape protect mode (drum head rotation stopped) is engaged when the record-standby condition continues.</p> <p>3MIN : 3 minutes 5MIN : 5 minutes</p> <p>* When used in a cold environment or when the stopped or STILL status continues, the setting will be 3 minutes or less regardless of the setting on the menu. * Normally, set "3MIN" and use this to prevent head clogging and tape damage.</p>
ALARM VR LEVEL	<p>Selects whether or not alarm sound is emitted and the volume of the alarm sound. The alarm sound is output through the monitoring loudspeaker and the PHONES jack.</p> <p>OFF : Sound is not output. LOW : Alarm sound is soft. MIDDLE : Alarm sound is normal. HIGH : Alarm sound is loud.</p>
FRONT TALLY	<p>Selects the lighting method of the FRONT TALLY lamp during recording.</p> <p>BLINK : The lamp blinks from when the REC/VTR trigger is pressed and until recording starts. The lamp lights steadily during recording. ON : The lamp lights only during recording. OFF : The lamp is always off.</p>
BACK TALLY	<p>Selects the lighting method of the BACK TALLY lamp during recording.</p> <p>BLINK : The lamp blinks from when the REC/VTR trigger is pressed and until recording starts. The lamp lights steadily during recording. ON : The lamp lights only during recording. OFF : The lamp is always off.</p>
FORMAT LED	<p>Sets whether or not the [HDV/DV LED]  on page 15 lights for HDV format or DV format.</p> <p>ON : Lights. OFF : Does not light.</p>
GENLOCK..	<p>Calls up the GENLOCK menu screen. Adjusts the H PHASE or SC PHASE of image signals of this device according to the external synchronization signal input to the [GENLOCK IN] terminal.  See page 99.</p>
NEXT PAGE	To display the OTHERS[2/2] menu screen, move the cursor to this position and press the SHUTTER dial.
PAGE BACK	The TOP MENU screen returns when the SHUTTER dial is pressed while the cursor is at this position.





OTHERS[2/2] Menu Screen

* This is not displayed in VTR mode.

Item	Function/Setting (bold characters indicate initial settings)																																							
1394 REC TRIGGER*	<p>Sets how to control the REC trigger command output from the IEEE1394 connector. (Can be displayed and set in camera mode) Set this when recording a backup of the HDV/DV signal from GY-HD250/GY-HD251 onto another device. OFF : Does not control the backup device. SYNCRO : Controls the backup device in conjunction with the recording start/stop mode status on this device, and if there is no videocassette or if no tape remains for recording, controls the backup device in conjunction with the REC trigger button and the lens VTR button on this device. SPLIT : The REC trigger button on the right panel of this device controls the backup device recording start/stop. Set this when you want to control the timing of the recording on this device and the backup device separately. SERIES : Automatically starts recording on a backup device that is on Pause when the tape on this device has less than 3 minutes remaining during shooting.</p> <p>MEMO</p> <ul style="list-style-type: none"> • If you use the backup recording function on the BR-HD50, set this item to OFF. • The cursor (▶) does not move to this item when this device is recording. 																																							
BACK SPACE [HDV]*	<p>This function controls the camera tape transport, back space and pre-roll time when the camera is connected to an external HDD or external back up Recorder via IEEE1394 in HDV mode. P-1394 : Priority for IEEE1394 recording (Auto setting) P-TAPE : Priority for camera VCR recording</p> <table border="1" data-bbox="389 1010 1473 1630"> <thead> <tr> <th data-bbox="389 1010 612 1093">BACK SPACE [HDV]</th> <th data-bbox="612 1010 807 1093">IEEE1394 connection</th> <th data-bbox="807 1010 1007 1093">1394 REC TRIGGER (▶ See page 97)</th> <th data-bbox="1007 1010 1203 1093">Internal VCR start delay</th> <th data-bbox="1203 1010 1473 1093">External Recorder or HDD via IEEE1394 terminal</th> </tr> </thead> <tbody> <tr> <td data-bbox="389 1093 612 1361" rowspan="8">P-1394</td> <td data-bbox="612 1093 807 1227" rowspan="4">Connected and Power ON</td> <td data-bbox="807 1093 1007 1122">OFF</td> <td data-bbox="1007 1093 1203 1227" rowspan="4">approx. 3 seconds</td> <td data-bbox="1203 1093 1473 1122">N/A</td> </tr> <tr> <td data-bbox="807 1122 1007 1151">SYNCRO</td> <td data-bbox="1203 1122 1473 1151">See Note 1</td> </tr> <tr> <td data-bbox="807 1151 1007 1180">SPLIT</td> <td data-bbox="1203 1151 1473 1180">See Note 2</td> </tr> <tr> <td data-bbox="807 1180 1007 1227">SERIES</td> <td data-bbox="1203 1180 1473 1227">N/A</td> </tr> <tr> <td data-bbox="612 1227 807 1361" rowspan="4">No connection or Power OFF See Note 4</td> <td data-bbox="807 1227 1007 1256">OFF</td> <td data-bbox="1007 1227 1203 1361" rowspan="4">approx. 1 second</td> <td data-bbox="1203 1227 1473 1361" rowspan="4">N/A</td> </tr> <tr> <td data-bbox="807 1256 1007 1285">SYNCRO</td> </tr> <tr> <td data-bbox="807 1285 1007 1314">SPLIT</td> </tr> <tr> <td data-bbox="807 1314 1007 1361">SERIES</td> </tr> <tr> <td data-bbox="389 1361 612 1630" rowspan="8">P-TAPE</td> <td data-bbox="612 1361 807 1496" rowspan="4">Connected and Power ON</td> <td data-bbox="807 1361 1007 1391">OFF</td> <td data-bbox="1007 1361 1203 1496" rowspan="4">approx. 1 second</td> <td data-bbox="1203 1361 1473 1391">See Note 3</td> </tr> <tr> <td data-bbox="807 1391 1007 1420">SYNCRO</td> <td data-bbox="1203 1391 1473 1496" rowspan="4">N/A</td> </tr> <tr> <td data-bbox="807 1420 1007 1449">SPLIT</td> </tr> <tr> <td data-bbox="807 1449 1007 1496">SERIES</td> </tr> <tr> <td data-bbox="612 1496 807 1630" rowspan="4">No connection or Power OFF</td> <td data-bbox="807 1496 1007 1525">OFF</td> <td data-bbox="1007 1496 1203 1630" rowspan="4">approx. 1 second</td> <td data-bbox="1203 1496 1473 1630" rowspan="4">N/A</td> </tr> <tr> <td data-bbox="807 1525 1007 1554">SYNCRO</td> </tr> <tr> <td data-bbox="807 1554 1007 1583">SPLIT</td> </tr> <tr> <td data-bbox="807 1583 1007 1630">SERIES</td> </tr> </tbody> </table> <p>Note 1: REC start signal will be sent 3 seconds after pressing REC trigger button. * Actual recording start time is depending on recorder performance.</p> <p>Note 2: REC start signal will be sent just after pressing REC trigger button. * Actual recording start time is depending on recorder performance.</p> <p>Note 3: In this mode, the IEEE1394 stream is discontinuous during internal VCR back space editing (when the REC trigger is operated). This may result in breaks in the recording on tape on an external recorder. In the case of HDD recording this may result in this device staying in REC PAUSE or divided files.</p> <p>Note 4: If HD/SD SDI OUT on the VIDEO FORMAT[2/2] menu screen is set to ON, the internal VCR start delay becomes approximately 3 seconds.</p> <p>MEMO</p> <p>The cursor (▶) does not move to this item when this device is recording.</p>	BACK SPACE [HDV]	IEEE1394 connection	1394 REC TRIGGER (▶ See page 97)	Internal VCR start delay	External Recorder or HDD via IEEE1394 terminal	P-1394	Connected and Power ON	OFF	approx. 3 seconds	N/A	SYNCRO	See Note 1	SPLIT	See Note 2	SERIES	N/A	No connection or Power OFF See Note 4	OFF	approx. 1 second	N/A	SYNCRO	SPLIT	SERIES	P-TAPE	Connected and Power ON	OFF	approx. 1 second	See Note 3	SYNCRO	N/A	SPLIT	SERIES	No connection or Power OFF	OFF	approx. 1 second	N/A	SYNCRO	SPLIT	SERIES
BACK SPACE [HDV]	IEEE1394 connection	1394 REC TRIGGER (▶ See page 97)	Internal VCR start delay	External Recorder or HDD via IEEE1394 terminal																																				
P-1394	Connected and Power ON	OFF	approx. 3 seconds	N/A																																				
		SYNCRO		See Note 1																																				
		SPLIT		See Note 2																																				
		SERIES		N/A																																				
	No connection or Power OFF See Note 4	OFF	approx. 1 second	N/A																																				
		SYNCRO																																						
		SPLIT																																						
		SERIES																																						
P-TAPE	Connected and Power ON	OFF	approx. 1 second	See Note 3																																				
		SYNCRO		N/A																																				
		SPLIT																																						
		SERIES																																						
	No connection or Power OFF	OFF	approx. 1 second		N/A																																			
		SYNCRO																																						
		SPLIT																																						
		SERIES																																						

**OTHERS[2/2] Menu Screen
(Cont'd)**

* This is not displayed in VTR mode.

Item	Function/Setting (bold characters indicate initial settings)
DR-HD100 A.OFF*	<p>Selects whether or not to turn OFF the DR-HD100 (HDD unit by FOCUS enhancements) when this device is turned OFF.</p> <p>OFF : Power does not turn OFF. ON : Power turns OFF with this device.</p> <p>MEMO</p> <ul style="list-style-type: none"> • The  mark is displayed at the upper right of the LCD monitor and viewfinder when the DR-HD100 is connected. If this device is turned OFF before the mark is displayed, power does not turn OFF even if this setting is ON. • This setting is canceled and the DR-HD100 does not turn OFF in the following instances. <ul style="list-style-type: none"> - 1394 REC TRIGGER item is set to OFF - VTR mode is set • When the DR-HD100 power turns off and this device is turned ON again, after 12 seconds, "DR-HD100 power?" appears on the LCD monitor for 7 seconds.
MENU ALL RESET	<p>Selects whether to reset the menu screen settings to initial settings. The camera mode and VTR mode menu settings are reset. (The TC PRESET, UB PRESET, and CLOCK ADJUST settings are not reset.)</p> <p>CANCEL : The settings are not reset. EXECUTE : The settings are reset.</p> <p>MEMO</p> <ul style="list-style-type: none"> • The cursor () does not move to this item when the VTR is activated. • If the current menu settings and the factory settings have different FRAME RATE settings, "REBOOT!" is displayed for 3 seconds, this device automatically turns off and then turns on.
PAGE BACK	<p>When the cursor is in this position, press the SHUTTER dial once to return to the OTHERS[1/2] menu screen.</p>
DRUM HOUR	<p>Displays the drum usage time. Use as an estimate for regular maintenance. The cursor () does not move to this item.</p>
FAN HOUR	<p>Displays the fan motor usage time. Use as an estimate for regular maintenance. The cursor () does not move to this item.</p>

GENLOCK Menu Screen

Item	Function/Setting (bold characters indicate initial settings)
SD H PHASE ^{*1}	Adjusts the horizontal (H) phase of the SD signal of this device according to the BB (Black Burst) signal input to the [GENLOCK IN] terminal. Increase the number : Proceed horizontal phase. Decrease the number : Delay horizontal phase. [Settings: MIN, -31 to -1, 0 , 1 to 86, MAX]
HD H PHASE	Adjusts the horizontal (H) phase of the HD signal and HD/SD SDI signal of this device according to the HD Tri-sync signal input to the [GENLOCK IN] terminal. In addition, during Tri-sync signal input, H PHASE of SD analog signals are simultaneously adjusted in HD H PHASE item. Increase the number : Proceed horizontal phase. Decrease the number : Delay horizontal phase. [Settings: MIN, -1023 to -1, 0 , 1 to 1022, MAX] MEMO When adjusting the HD H PHASE, the setting value quickly changes while the USER1 or USER2 button is held down for approximately two seconds.
SC COARSE ^{*1}	Adjusts the phase of the subcarrier (SC) of the composite or YC separate signal of this device according to the BB (Black Burst) signal input to the [GENLOCK IN] terminal. Increase the number : Proceed phase. Decrease the number : Delay phase. [Settings: 0° , 90°, 180°, 270°]
SC FINE ^{*1}	Fine-tunes the phase of the subcarrier (SC) of the composite or YC separate signal of this device according to the BB (Black Burst) signal input to the [GENLOCK IN] terminal. Increase the number : Proceed phase. Decrease the number : Delay phase. [Settings: MIN, -127 to -1, 0 , 1 to 126, MAX]
PAGE BACK	When the cursor is in this position, press the SHUTTER dial once to return to the OTHERS[1/2] menu screen.

^{*1} REMOTE appears as the setting value of this item when the remote control unit is connected.

- The setting value quickly changes while the USER1 or USER2 button is held down for approximately two seconds.

FILE MANAGE Menu Screen

You can perform the following operations in the FILE MAN-AGE menu screen.

- Settings corresponding to shooting conditions can be read immediately with the following read-only files.
 - LIVE HD60P : Ideal setting for HD60P format
 - LIVE HD50P : Ideal setting for HD50P format
 - CINEMA HD24P : Ideal setting for movie-quality shooting
- * The read-only files listed above cannot be saved or reset.
- Save menu settings (Camcorder: CAM1, 2, 3, 4; SD memory card: EXT1, 2, 3, 4) to files.
- Load saved files.
- You can set a SUB NAME for the file to be saved.
- Reset the menu settings to the factory settings.
- Initialize (format) an SD memory card.
- When you set CANCEL for the LOAD, STORE, RESET and FORMAT SD CARD items, these operations are not executed.
- A message is displayed in the LCD monitor or the viewfinder.
 - EXECUTE : Displayed for 3 seconds
 - COMPLETE : Displayed for 3 seconds
 - ERROR : Flashes (Error displays See page 101.)

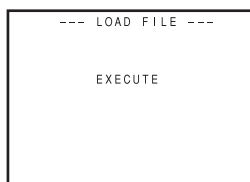

Execute

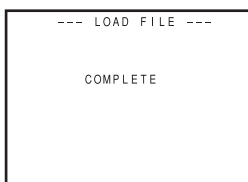

Complete

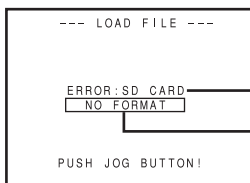

Error

Flashing
Error display

If there is an error:

- Press the STATUS button → Return to the normal screen.
- Press the SHUTTER dial → Return to the FILE MAN-AGE menu screen.
- To exit the FILE MANAGE screen: Move the cursor (▶) to PAGE BACK and press the SHUT-TER dial or press the STATUS button.

Displaying the FILE MANAGE menu screen

Select the FILE MANAGE.. item on the TOP MENU screen.

Loading a menu settings file

Select the LOAD FILE.. item on the FILE MANAGE menu screen.

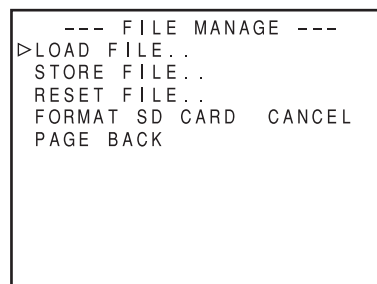

FILE MANAGE menu screen

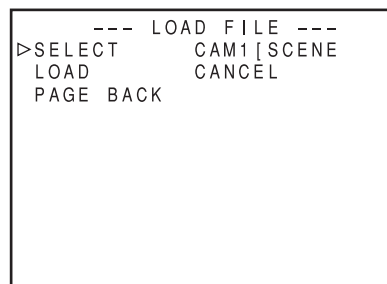

- Turn the SHUTTER dial, bring the cursor (▶) to SELECT and press the SHUTTER dial.
 - The file name setting area flashes.
- Turn the SHUTTER dial, select the file to load and press the SHUTTER dial.
- Turn the SHUTTER dial, bring the cursor (▶) to the LOAD item and press the SHUTTER dial.
 - EXECUTE flashes.
- With EXECUTE selected, press the SHUTTER dial to read the menu settings in the selected file.

If the current menu settings and the menu settings to be loaded have different video format settings, "REBOOT!" is displayed for 3 seconds, this device turns off automatically and then turns on.



Reboot display

CAUTION

This device cannot load scene files from GY-HD100/GY-HD110-series devices.

Saving settings

Select the STORE FILE.. item on the FILE MANAGE menu screen.

1. Turn the SHUTTER dial, bring the cursor (▶) to SELECT and press the SHUTTER dial.
 - The file name setting area flashes.
2. Turn the SHUTTER dial, select the file to save to, and press the SHUTTER dial.

```

--- STORE FILE ---
>SELECT      CAM1 [SCENE ]
EDIT
SUB NAME    [SCENE ]
STORE      OVERWRITE
PAGE BACK
  
```

■ Setting a SUB NAME

If you do not want to set a SUB NAME, go to Step 5..

3. Turn the SHUTTER dial, bring the cursor (▶) to SUB NAME and press the SHUTTER dial.
 - The first character in the file name flashes.

```

--- STORE FILE ---
SELECT      CAM1 [SCENE ]
EDIT
> SUB NAME  [SCENE ]
STORE      OVERWRITE
PAGE BACK
  
```

Settable Characters

```

ABCDEFGHIJKL MNOPQRST UVWXYZ-
1234567890
  
```

Space

4. Turn the SHUTTER dial, select the character, and press the SHUTTER dial.
 - The second character in the file name flashes.
 Repeat Step 4. up through the eighth character.

5. Turn the SHUTTER dial, bring the cursor (▶) to the STORE item and press the SHUTTER dial.
 - EXECUTE (if the file already exists, "OVERWRITE") flashes.

```

--- STORE FILE ---
SELECT      CAM1 [SCENE ]
EDIT
SUB NAME    [SCENE ]
▶STORE      OVERWRITE
PAGE BACK
  
```

6. With EXECUTE selected, turn the SHUTTER dial to save the menu settings to the selected file.

```

--- STORE FILE ---

EXECUTE
  
```

Execute

```

--- STORE FILE ---

COMPLETE
  
```

Complete

Error displays

- **NO CARD:**
No SD memory card is inserted.
Insert an SD memory card.
- **NO FORMAT:**
The SD memory card is not initialized (formatted).
Initialize (format) the SD memory card.
- **NO ACCESS:**
There is a problem with the SD memory card.
Replace the SD memory card.
- **WRITE PROTECT:**
The SD memory card may be write-protected.
Check that write-protection is disabled.
- **DISK FULL:**
The SD memory card does not have enough free space.
Delete unwanted data or initialize (format) the card.
- **INVALID VIDEO FORMAT:**
A settings file for a video format that is not supported was called up.
Settings files for video formats that are not supported cannot be called up.
- **READ ONLY FILE:**
Indicates a read-only file.
Read-only files cannot be saved.

```

--- STORE FILE ---

ERROR:SD CARD
NO FORMAT

PUSH JOG BUTTON!
  
```

Flashing

Error display

Error

FILE MANAGE Menu Screen (Cont'd)

Resetting the menu settings to the factory settings

Select the RESET FILE.. item on the FILE MANAGE menu screen.

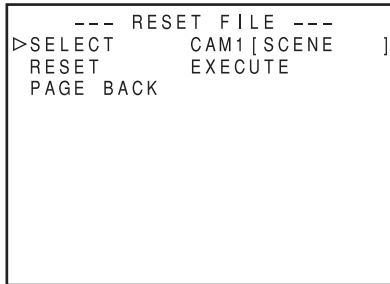

1. Turn the SHUTTER dial, bring the cursor (▶) to SELECT and press the SHUTTER dial.
 - The file name setting area for the file to be reset flashes.
2. Turn the SHUTTER dial, select the name of the file to reset, and press the SHUTTER dial.
 - CAM1, CAM2, CAM3, CAM4, CURRENT (current settings)
3. Turn the SHUTTER dial, bring the cursor (▶) to the RESET item and press the SHUTTER dial.
 - EXECUTE flashes.
4. With EXECUTE selected, press the SHUTTER dial to reset the settings.



Execute



Complete

If the current menu settings and the factory settings have different video format settings, "REBOOT!" is displayed for 3 seconds, this device turns off automatically and then turns on.



Reboot display

When this happens, the SUB NAME initial value, "[SCENE]" is displayed.

MEMO

Even if CAM1, CAM2, CAM3, or CAM4 are reset, the current settings are not reset.

To reset the currently set values, select "CURRENT".

Initializing (formatting) an SD memory card

Before initializing (formatting) a card:

1. Insert and remove the SD memory card with the power to this device OFF.
2. Disable write-protection on the SD memory card.
3. Check that an SD memory card has been inserted into this device.

1. Turn the SHUTTER dial, bring the cursor (▶) to the FORMAT SD CARD item and press the SHUTTER dial.
 - CANCEL flashes.
2. Turn the SHUTTER dial, and when EXECUTE flashes, press the SHUTTER dial to initialize (format) the card.

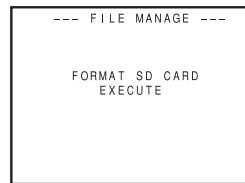

Execute



Complete

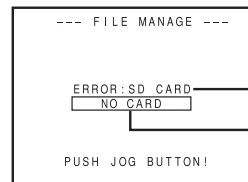

Error

Flashing

Error display

If there is an error:

Check items 2 and 3 in "Before initializing (formatting) a card".

How to Use Skin Detail

This function suppresses edge sharpening in the skin color areas of the video signal, enabling velvety, smooth skin tones.

Setting the skin detail function color and range

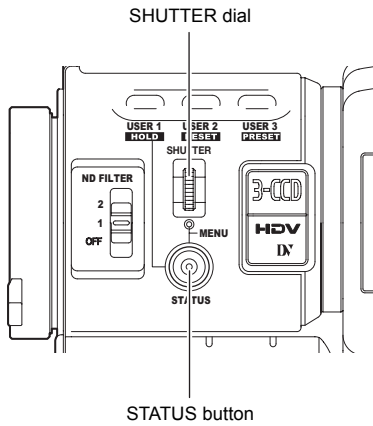

1. Display the ADVANCED PROCESS menu screen. In menu setting procedure TOP MENU screen → CAMERA PROCESS[1/2] → CAMERA PROCESS[2/2] → Select ADVANCED PROCESS item.

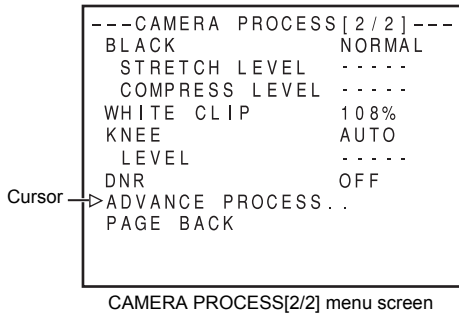

2. Turn the SHUTTER dial, bring the cursor (▶) to the SKIN COLOR ADJUST item and press the SHUTTER dial.
 - The SKIN COLOR ADJUST screen is displayed.
 - The entire screen becomes black and white, and only the areas recognized by the skin detail function are displayed in color.

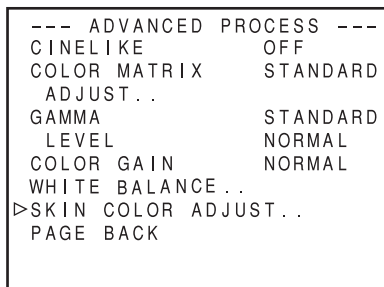

3. Move the cursor (▶) to the SKIN COLOR DET. item, press the SHUTTER dial and select EXECUTE to switch to skin color detection mode.
4. Shoot so that the color area you want to detect within the detection area frame is input. To confirm the detection area, press the SHUTTER dial and set SKIN COLOR DET. to STOP.
 - The frame on the screen is the detection area for the skin detail function.
 - The color within the detection area is recognized as the color that the skin detail function will use.
 - If the color within the detection area is not recognized as the color that the skin detail function will use, "ERROR" is displayed on the screen.

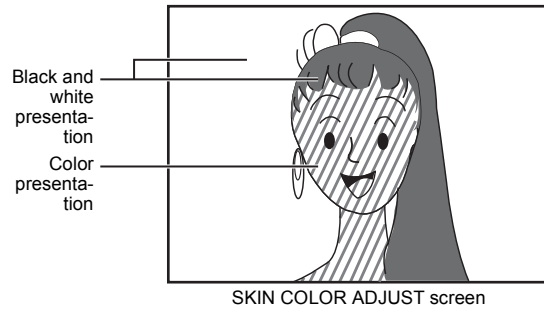
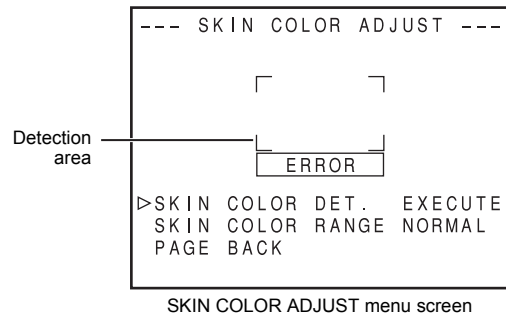

5. If you want to change the range of colors recognized with the skin color detection function, follow the steps below.
 - 1 Turn the SHUTTER dial, bring the cursor (▶) to the SKIN COLOR RANGE item and press the SHUTTER dial.
 - The setting area flashes and can be changed.
 - 2 Turn the SHUTTER dial up or down to widen or narrow the color range.
 - Set the range as you check the color display.
 - 3 To confirm the color range, press the SHUTTER dial.
 - The setting returns to its lit state.
6. To stop the SKIN COLOR ADJUST function, turn the SHUTTER dial, bring the cursor (▶) to the PAGE BACK item and press the SHUTTER dial.

How to Use Skin Detail (Cont'd)

Using the Skin Detail Function

To use the skin detail function set on the SKIN COLOR ADJUST screen, select "ON" for the SKIN DETECT item on the CAMERA PROCESS[1/2] menu screen.

In addition, you can use the LEVEL item to set three levels of suppression of skin color area detail enhancement in the video signal. See page 81.

While the skin detail function operates, the "SD" indicator is displayed on the STATUS 0 and STATUS 1 screen in the viewfinder or LCD monitor.

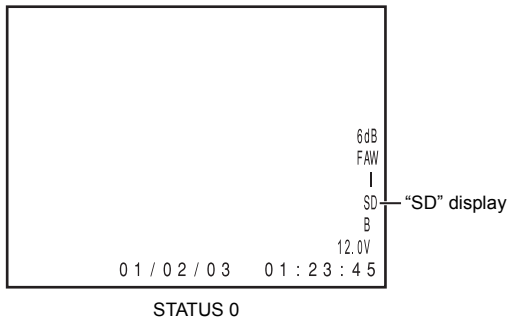

Confirming the color tone area adjusted with the Skin Detail function

When you push the ZEBRA switch on the front panel to "SKIN AREA", the skin detail function turns ON, and the color area adjusted with the skin detail function is displayed in color in the LCD monitor or viewfinder.

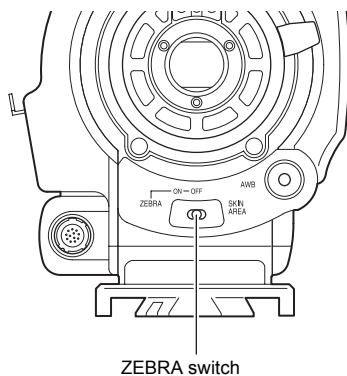

MEMO

- When the REVERSE PICTURE item in the CAMERA PROCESS[2/2] menu screen is set to ROTATE, skin detail function is available but the detection area is not displayed in the viewfinder or LCD screen.
- When COLOR GAIN item on the ADVANCED PROCESS menu screen is set to "OFF", only the portion the skin detail function is working is displayed in skin color. See page 83.

Outputting Color Bars

GY-HD250/GY-HD251 can output three types of color bars, depending on the camera settings.

NTSC standard : Outputs color bars compliant with the SMPTE standard.

PAL standard : Outputs color bars compliant with the EBU standard.

16:9 screen : Outputs multi-format color bars.

To output color bars, make the following settings.

1. Turn the FULL AUTO switch to "OFF".
2. Set the BARS item on the CAMERA OPERATION menu screen to "ON".  See page 80.
 - Color bars are output.

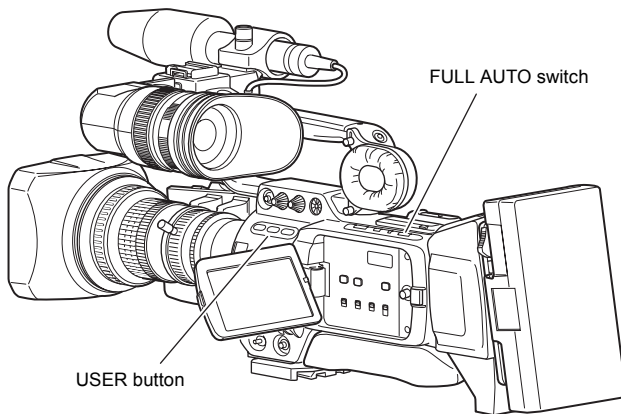

■ Outputting color bars using the USER buttons

1. Turn the FULL AUTO switch to "OFF".
2. Assign "BARS" to one of the USER1, 2 or 3 buttons.
 -  See "SWITCH MODE Menu Screen" on page 86.
3. Press the USER button to which "BARS" was assigned.
 - Color bars are output.

MEMO

- You can select whether to output an audio test signal during color bar output using the TEST TONE item on the AUDIO/MIC[1/2] menu screen.  See page 87.
 - Color bars are not output when FULL AUTO mode is ON or in VTR mode.
-

Warnings and Responses

Warnings are displayed on the LCD monitor or the viewfinder if there was a mistaken operation, if the battery or tape is low, or if there is a problem on the VTR.

In addition, if the tape or battery is low or the VTR has a problem, the tally lamp flashes (or lights) and an alarm is output from the monitor speaker or PHONES jack.

MEMO

GY-HD250/GY-HD251 uses microcomputers. It may not operate properly if there is external static or interference. If this happens, turn the power off and then on again.

Display	Status	Action
60/30 INHIBIT CHANGE FRAME RATE MENU	The FRAME RATE item is set to 50/25 or 24, and a tape recorded in 60/30 frame is played back or it is input into the IEEE1394 port in VTR mode.	Sets the FRAME RATE item on the VIDEO FORMAT menu screen to match the frames. ☞ See page 77.
50/25 INHIBIT CHANGE FRAME RATE MENU	The FRAME RATE item is set to 60/30 or 24, and a tape recorded in 50/25 frame or it is input into the IEEE1394 port in VTR mode.	
24 INHIBIT CHANGE FRAME RATE MENU	The FRAME RATE item is set to 50/25 or 60/30, and a tape recorded in 24 frame is played back or it is input into the IEEE1394 port in VTR mode.	
AUX IN INHIBIT CHANGE FRAME RATE MENU	<ul style="list-style-type: none"> • U model Displays when the FRAME RATE item is set to 50/25 or 24 and the GENLOCK/AUX IN switch is set to AUX IN. • E model Displays when the FRAME RATE item is set to 60/30 or 24 and the GENLOCK/AUX IN switch is set to AUX IN. 	Set the FRAME RATE item as shown below to input external images. U model : 60/30 E model : 50/25
SYNC LOCKING	Camera image is locking to external synchronization signals.	It is not possible to enter recording mode while "SYNC LOCKING" is displayed. Wait until the indication disappears.
PLEASE WAIT	Displays when external synchronization signal is input and REC trigger button is pressed while SYNC LOCKING is displayed.	
INVALID SYNC	<ul style="list-style-type: none"> • Displays when the FRAME RATE item is set to 60/30 or 24 and signals not supported by GENLOCK are input. • Displays when the FRAME RATE item is set to 50/25 and signals not supported by GENLOCK are input. 	Input supported external synchronization signals. ☞ See page 66.
DV-60I INVALID! DV-24P INVALID! DV-24PA INVALID!	A tape recorded in DV-60I, DV-24P, or DV-24PA format was played back or input into the IEEE1394 connector in VTR mode on the E model.	The E model cannot play back tapes recorded in DV-60I, DV-24P or DV-24PA format or input into the IEEE1394 connector in VTR mode.
DV-50I INVALID! DV-25P INVALID!	A tape recorded in DV-50I or DV-25P format was played back or input into the IEEE1394 connector in VTR mode on the U model.	The U model cannot play back tapes recorded in DV-50I or DV-25P format or input into the IEEE1394 connector in VTR mode.
HDV-SD60P INVALID!	A tape recorded in HDV-SD60P format was played back or input into IEEE1394 connector in VTR mode.	GY-HD250/GY-HD251 cannot play back or input an HDV-SD60P/HDV-SD50P signal.
HDV-SD50P INVALID!	A tape recorded in HDV-SD50P format was played back or input into IEEE1394 connector in VTR mode.	
INVALID TAPE!	A computer data tape or a DVC PRO cassette was used.	Use a MiniDV videocassette.
LP TAPE INVALID!*	Tried to play back a tape recorded in LP mode.	GY-HD250/GY-HD251 cannot record or play back in LP mode.
NO DV SIGNAL*	DV signal was not input.	Set the IEEE1394 switch to DV and input a DV signal.
NO HDV SIGNAL*	HDV signal was not input.	Set the IEEE1394 switch to HDV and input an HDV signal.
COPY INHIBIT*	Tried to record a copyguarded signal.	Cannot record a copyguarded signal.
REC INHIBIT*	A tape that cannot be recorded (back switch is set to SAVE) was inserted.	Set the switch on the back of the cassette tape to REC.
NO TAPE*	No videocassette tape is inserted.	Insert a cassette tape.

Display	Status	Action
CHANGE PB TAPE FORMAT*	Image format which is different from the one set in the PB TAPE item on the VIDEO FORMAT[2/2] menu screen is being played back.	Check the setting for the PB TAPE item. ☞ See page 79.
LOW VOLTAGE*	Battery is low.	Charge the battery pack or replace it.
TAPE NEAR END*	There are less than 3 minutes remaining on the tape (flashes only when recording).	To continue shooting, find a new tape or replace the tape.
TAPE END*	Displayed when the tape ends.	Replace the tape.
CHANGE 1394 SWITCH*	Recording or playback video format and the IEEE1394 setting is different when connected to the IEEE1394 port.	Set the IEEE1394 switch correctly, turn the power off and then on again.
SWITCH TO VTR MODE*	Tried to use the FF or REW button in camera mode.	Press the CAM/VTR button to set VTR mode.
HEAD CLEANING REQUIRED	Displayed when the video head is dirty. (Head clogging was detected during an edit search in shooting mode as well as during playback and displayed.)	Clean with a special head cleaning tape. ☞ See page 7.
CLEANING TAPE!	Displayed when a head cleaning tape is inserted.	The display disappears when the head cleaning tape is removed.
COPY GUARD!*	Tried to play back a copyguarded tape.	Cannot play back a copyguarded tape.
FAN MOTOR HOUR	Over the prescribed fan motor usage time.	Please contact your local dealer or JVC.
PUSH CASSETTE COVER*	The videocassette cover is not firmly shut.	Lightly push the top center of the videocassette cover.
CHANGE THE SYSTEM*	Displayed when you attempt to change FRAME RATE item in the VIDEO FORMAT menu screen.	When the FRAME RATE item setting is changed, the frame rate system for this device is changed. Check the frame rate to use before changing the setting. ☞ See pages 54 and 77.

* When status indications are magnified, warnings are not displayed on the LCD monitor.

☞ See "Magnified Status Indications on the LCD Monitor" on page 29.

Warnings and Responses (Cont'd)

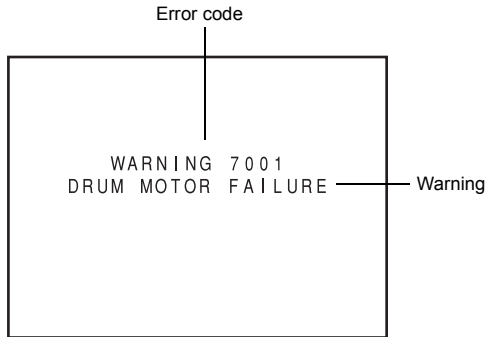

- Warning Indications for VTR Abnormalities**
 Should malfunctions occur during VTR operation, this device self-diagnoses the cause and shows the diagnose together with an error code on the LCD monitor or in the viewfinder.

Error Code	Error Details	GY-HD250/GY-HD251 Operation	Remedy
0201 CONDENSATION ON DRUM	Indicates dew formation (condensation).	Operation stops. All operations are rejected.	Leave this device with the power ON, until the indication disappears. ☞ See page 9. Switch the power OFF and then switch it back ON. However, the tape may be damaged depending on the circumstances. Please consult the person in charge of professional video equipment at your nearest JVC-authorized service agent.
3200 LOADING FAILURE	Tape cannot be loaded.		
3300 UNLOADING FAILURE	Tape cannot be unloaded.		
4100 CASSETTE EJECT FAILURE	Irregularity with eject operation.		
5605 - 5609 DEFECTIVE TAPE	Tape is cut.	Operation stops.	Press the EJECT button to take out the cassette. If the tape runs out during recording, switch the power OFF and then switch it back ON, press the EJECT button, and then take out the cassette.
5702 TAPE END DET. ERROR	Tape end sensor error.	Operation stops. All operations are rejected.	Switch the power OFF and then switch it back ON. However, the tape may be damaged depending on the circumstances. Please consult the person in charge of professional video equipment at your nearest JVC-authorized service agent.
5802 TAPE BEGIN DET. ERROR	Tape beginning sensor error.		
7001 DRUM MOTOR FAILURE	Drum rotation error.		
7101 CAP MOTOR FAILURE	Capstan rotation error.		
7202 - 7203 SUPPLY REEL FAILURE	Supply reel rotation error.		
7302 - 7303 TAKE UP REEL FAILURE	Take up reel rotation error.		
7305 TAKE UP REEL FAILURE	Take up reel rotation error when unloading.		
8000 EMERGENCY TAPE!	Tape problem detected.		
TURN POWER OFF. TURN BACK ON LATER.	System error when power is turned on.		

■ TALLY lamp

Blinks when remaining battery power or tape is low. (Only in Camera mode)

Blinking Pattern	Remaining Battery/Tape
Slow blinking (once per sec.)	<ul style="list-style-type: none"> • Remaining battery power is low. • Remaining tape time is equivalent to less than 3 minutes.
Fast blinking (four times per sec.)	<ul style="list-style-type: none"> • Tape has run out. • Irregularity has occurred in the VTR.

■ Alarm Sound







When remaining battery power becomes low, a warning sound is output from the monitoring loudspeaker and the PHONES jack.

(In Camera mode only)

When an irregularity occurs in the VTR, a warning sound is also output.

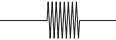
Whether or not alarm sound should be output and the volume level are selected with the ALARM VR LEVEL item on the OTHERS[1/2] menu screen.

■ Depending on the alarm conditions, the warning indicators on the LCD monitor/viewfinder screen, the TALLY lamp, and alarm sounds appear as shown in the following table.

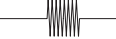
Alarm Indications on LCD Monitor/ Viewfinder Screen	TALLY lamp	Alarm Sound	Condition
VTR alarm indication (Example) <div style="border: 1px solid black; padding: 2px; width: fit-content; margin: 5px auto;">7001 DRUM MOTOR FAILURE</div>			Dew formation (condensation) or error has occurred in the VTR.
<div style="border: 1px solid black; padding: 2px; width: fit-content; margin: 5px auto;">TAPE NEAR END</div>			About 3 min. before tape end (displayed during recording).
<div style="border: 1px solid black; padding: 2px; width: fit-content; margin: 5px auto;">TAPE END</div>			Tape end (displayed during recording).
<div style="border: 1px solid black; padding: 2px; width: fit-content; margin: 5px auto;">LOW VOLTAGE</div>			Remaining battery power is low.

Display symbols



 : Blinking once per second.

 : Sound interrupted once per second.

 : Blinking four times per second.

 : Continuous sound.

Troubleshooting

Symptoms	Remedy
Power cannot be switched ON.	<ul style="list-style-type: none"> • Is power supply connected correctly? • Is battery pack recharged? • Was the power turned ON immediately after being turned OFF? Wait at least 5 seconds before turning the power ON again once it has been turned OFF.
Recording is not possible.	<ul style="list-style-type: none"> • Is the REC LOCK switch on the handle set to ON? • Is the switch on cassette set to "REC"? If it is set to "SAVE", set it to "REC". • The Camera mode has not been selected. (The VTR indicator does not light.) While the VTR indicator lights, press the MODE switch upward to turn on the CAM indicator.
Camera image does not appear on LCD monitor or in viewfinder.	<ul style="list-style-type: none"> • The Camera mode has not been selected. (The VTR indicator does not light.) While the VTR indicator lights, camera image will not be output. Press the CAM/VTR switch upward to turn on the VTR indicator.
Image shown on LCD monitor or in viewfinder is dark or blurred.	<ul style="list-style-type: none"> • Adjust the brightness of the LCD monitor or viewfinder screen. • Is the ND filter knob set to 2? • Is the iris closed? • Is the shutter speed too fast? • Is the viewfinder cable correctly connected?
Playback does not start when the play button is pressed.	<ul style="list-style-type: none"> • In the Camera mode, is "STOP" indicated as the VTR operation mode indicator? When "STBY" is indicated, press the STOP button to display "STOP".
Cannot play back.	<ul style="list-style-type: none"> • Is the PB TAPE item on the VIDEO FORMAT menu screen set to a setting other than AUTO? If this menu item and the tape format do not match, the tape cannot be played back.
Cannot input an HDV/DV signal.	<ul style="list-style-type: none"> • Is this device in VTR mode? (Is the VTR indicator lit?) • Is the IEEE1394 switch set correctly?
Noise interferes with playback video.	<ul style="list-style-type: none"> • Video head may be clogged with dirt. Clean head with the special head cleaning tape.  See "Precautions for Use of Head Cleaning Tape" on page 7.
Sound is not output during playback.	<ul style="list-style-type: none"> • Is the AUDIO SELECT item on the AUDIO menu screen set to CH3/4? To output the sound of the recording, set to CH1/2.
Noise appears when playing back a tape recorded on another unit.	<ul style="list-style-type: none"> • When a tape recorded on another unit is played back or used for recording, this phenomenon may occur due to tracking errors.
The transient section between scenes recorded on other units and those recorded on the GY-HD250/GY-HD251 may appear disturbed.	
The front section's audio level control doesn't work.	<ul style="list-style-type: none"> • Is the CH-1/CH-2 AUDIO SELECT switch set to "AUTO"? • Is the FULL AUTO switch set to "ON"?
Cannot initialize (format) the SD memory card.	<ul style="list-style-type: none"> • Is the SD memory card write-protected?  See page 34.
Battery alarm is displayed even if a fully charged battery pack is put in.	<ul style="list-style-type: none"> • Is the battery pack old?
Cassette cannot be ejected after the power is turned ON.	<ul style="list-style-type: none"> • The capacity of the power supply may be insufficient. Check the power voltage.
Time code or user's bits data not displayed.	<ul style="list-style-type: none"> • Is the TC/UB item on the LCD/VF[3/4] menu screen set to OFF? If so, set to ON.
The date and time are not displayed or recorded.	<ul style="list-style-type: none"> • Is the DISPLAY item on the TIME/DATE menu screen set to OFF? Set to ON when the data should be displayed and recorded. • Is the date and time setting made?  See "Setting and Displaying the Date and Time" on pages 41, 42.
Video is not output from the [Y/Pb/Pr] terminal.	<ul style="list-style-type: none"> • Is VF SIGNAL on the LCD/VF[4/4] menu screen set to Y or COMPOSITE?
Viewfinder is not displayed properly.	<ul style="list-style-type: none"> • Is VF SIGNAL on the LCD/VF[4/4] menu screen set to a setting other than RGB?

How to Display the Hour Meter

The drum and fan motor usage times are displayed in the DRUM HOUR item and the FAN HOUR items on the OTHERS[2/2] menu screen as the hour meters on GY-HD250/ GY-HD251.

Use as an estimate for regular maintenance.  See page 7.

1. Turn the POWER switch ON.
2. Press the STATUS button for at least 1 second to display the TOP MENU screen.
3. Turn the SHUTTER dial, select the OTHERS.. item, and press the SHUTTER dial.
The OTHERS[1/2] menu screen is displayed.
4. Select the NEXT PAGE item on the OTHERS[1/2] menu screen and press the SHUTTER dial.
The OTHERS[2/2] menu screen is displayed.

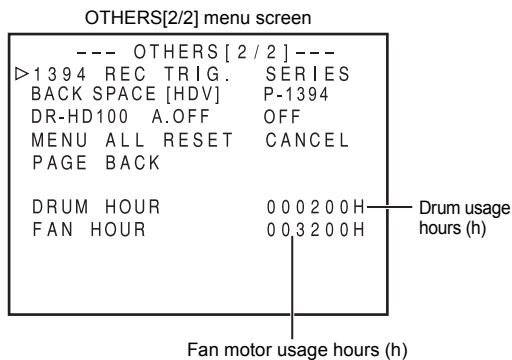

■ OTHERS[2/2] Menu Screen

DRUM HOUR item : Displays the drum usage hours.

FAN HOUR item : Displays the fan motor usage hours.

5. To return to the normal screen display, do one of the following:
 - Press the STATUS button.
 - or
 - Return to the TOP MENU screen, select the EXIT item on the TOP MENU screen and press the SHUTTER dial.

Specifications

[General]

Power requirements	: DC 12 V, \approx 2 A
Power consumption	: Approx. 24 W (in the Record mode)
Dimensions	: 224(W) \times 242.3(H) \times 401(D) mm (U model) 224(W) \times 242.3(H) \times 414(D) mm (E model)
Mass	: 3.6 kg(8.0 lbs.) (U model) 3.8 kg(8.4 lbs.) (E model) (including lens (Th16 \times 5.5BRMU), viewfinder, microphone and tape)
Temperature	
Operating	: 0°C to 40°C (32°F to 104°F)
Storage	: -20°C to 60°C (-4°F to 140°F)
Humidity	
Operating	: 30% to 80% RH
Storage	: 85% RH or less

[Camera section]

Image pickup device	: 1/3" interline-transfer CCDs
Color separation optical system	: F1.4, 3-color separation prism optical system
Number of total pixels	: Approx. 1,110,000 pixels
Color bars	: SMPTE/EBU type Sync system: Internal sync (built-in SSG)
Lens mount	: 1/3" bayonet system
ND filter	: 1/4ND, 1/16ND
Gain	: 0, 3, 6, 9, 12, 15, 18 dB, ALC
Electronic shutter	
Standard value	: 59.94 Hz (U model)/50 Hz (E model)
Fixed values	: 7.5 - 10,000 Hz, 11 steps (HDV HD30p/HDV HD60p/DV 60i), 6.25 - 10,000 Hz, 11 steps (HDV HD25p/HDV HD50p/DV 50i), 6 - 10,000 Hz, 12 steps (HDV HD24p/DV 24p), 6.25 - 10,000 Hz, 11 steps (DV 25p)
Variable scan	: 30.03 - 10,489.5 Hz (HDV HD60p/HDV HD30p/DV 60i) 25.04 - 10,489.5 Hz (HDV HD50p/HDV HD25p/DV 50i/DV 25p) 24.01 - 10,489.5 Hz (HDV HD24p/DV 24p)
Dynamic range	: 300% or more

[VTR section]

Video

Recording format	: 720/24p, 720/25p, 720/30p, 720/50p, 720/60p (U/E model), 480/24p, 480/60i (U model), 576/25p, 576/50i (E model)
------------------	---

Video Format:

[HDV]

Video signal recording format	: HDV720p format, 8-bit, 19.7 Mbps
Compression	: MPEG-2 video (profile & level: MP@H-14)

[DV]

Video signal recording format	: DV format, 8-bit, 25 Mbps
Compression	: DV compression, 4:1:1 (NTSC)/4:2:0 (PAL)

Audio:

[HDV]

Audio signal recording format	: MPEG1 Audio Layer II
-------------------------------	------------------------

[DV]

Audio signal recording format	: 16-bit (locked audio), 48 kHz PCM for 2 channels or 12-bit, 32 kHz PCM for 4 channels
Usable tape	: MiniDV tape
Tape speed	: 18.8 mm/sec.
Record/play time	: 63 minutes (with an M-DV63PROHD tape)

[Time Code]

Time code signal	: Compliance with SMPTE/EBU standard
LTC input	: 0 dBs \pm 6 dBs, high impedance, unbalanced
LTC output	: 0 dBs \pm 6 dBs, low impedance, unbalanced

[Connectors]

AUX input

	: Composite video signals 1V (p-p) \pm 0.3V (p-p), 75 Ω unbalanced (BNC)
--	---

Genlock input

	: BB signals
	: SMPTE 170M (RS-170A) compliant NTSC
	: /ITU-R BT. 470-6 compliant PAL
	: HDTV Tri-sync signals
	: [SMPTE 296M/SMPTE 274M compliant] (BNC)

Analog composite output

	: 1.0 V (p-p), 75 Ω , unbalanced (RCA)
--	---

Analog component output

Y	: 1.0 V (p-p), 75 Ω , unbalanced (BNC)
P _B /P _R	: 0.7 V (p-p), 75 Ω , unbalanced (BNC)

HD/SD SDI output

	: SMPTE 292M compliant HD serial digital signals
	: /SMPTE 259M compliant SD serial digital signals (BNC)

Audio inputs

Mic	: -60 dBs, 3 k Ω , balanced (XLR), +48 V output for phantom power supply
Line	: +4 dBs, 10 k Ω , balanced (XLR)
Audio outputs	: -8 dBs, low impedance, unbalanced (RCA \times 2)
Earphone jack	: -17 dBs to -60 dBs, 8- Ω impedance (stereo mini-jack \times 2)
IEEE1394 connector	: 6-pin

[ACCESSORIES]

Lens	: 1 (Excluding the CHU/CHE model)
Microphone	: 1
Core Filter	: 1
Clamp Filter	: 4
SD memory card	: 1
Tripod base	: 1 (U model only)
Instruction Manual	: 1
Warranty Card	: 1
(USA and Canada only)	

For details, consult your JVC dealer.

EXTERNAL DIMENSIONS (unit: mm)

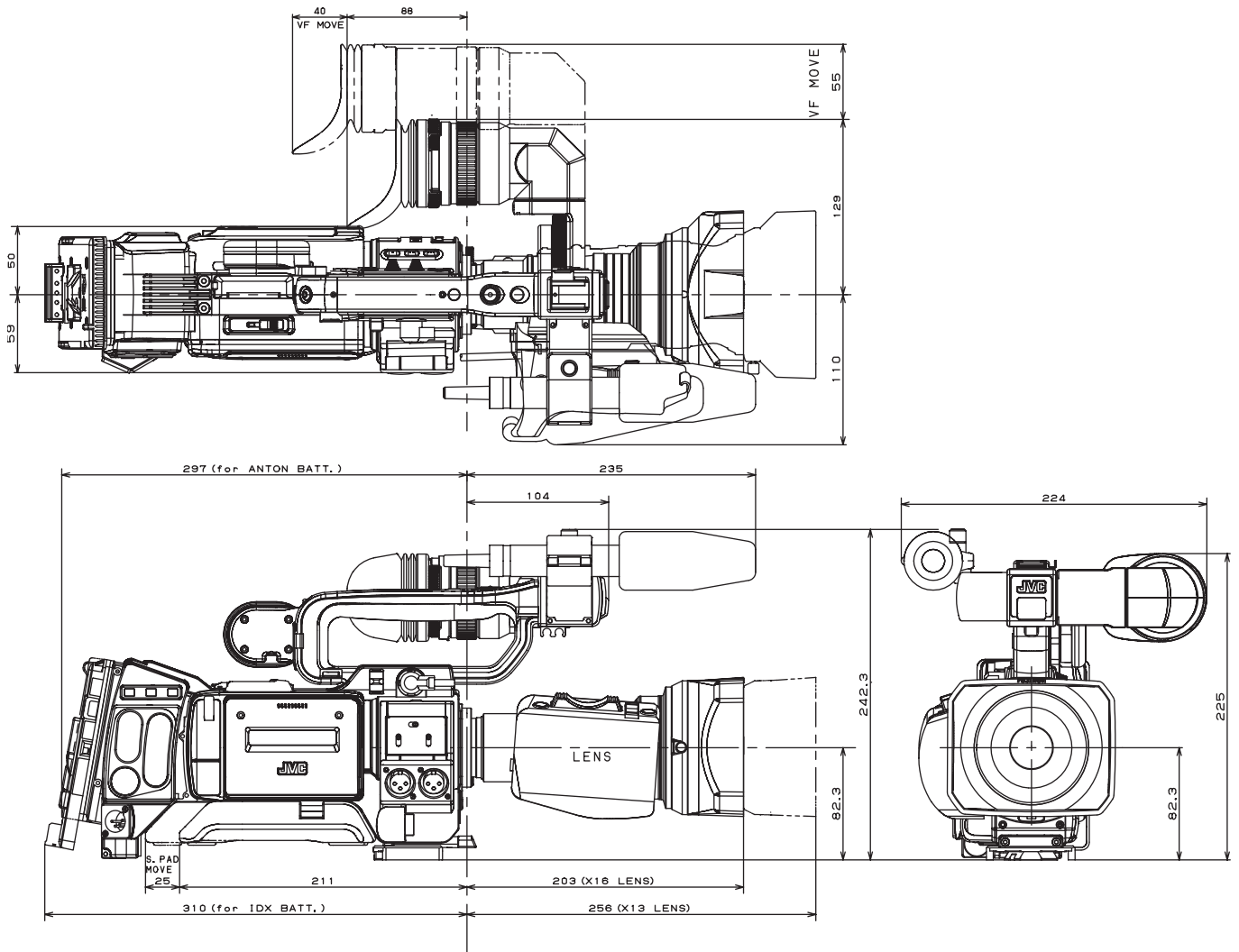

* Design and specifications are subject to change without notice.

JVC