

# JVC



LYT1717-001C

ENGLISH

**EN**

## ***INSTRUCTIONS***

---

**HARD DISK CAMCORDER**

**GZ-MG142E/EK**

**GZ-MG132E/EK**

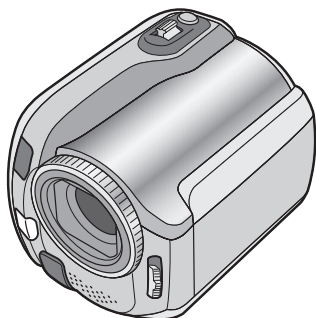

### **Dear Customer**

Thank you for purchasing this hard disk camera. Before use, please read the safety information and precautions contained in pages 2 and 3 to ensure safe use of this product.



# Safety Precautions

**IMPORTANT (for owners in the U.K.)**  
Connection to the mains supply in the United Kingdom.

**DO NOT cut off the mains plug from this equipment.**

If the plug fitted is not suitable for the power points in your home or the cable is too short to reach a power point, then obtain an appropriate safety approved extension lead or consult your dealer.

**BE SURE to replace the fuse only with an identical approved type, as originally fitted, and to replace the fuse cover.**

If nonetheless the mains plug is cut off be sure to remove the fuse and dispose of the plug immediately, to avoid possible shock hazard by inadvertent connection to the mains supply.

If this product is not supplied fitted with a mains plug then follow the instructions given below: **DO NOT** make any connection to the Larger Terminal coded E or Green.

The wires in the mains lead are coloured in accordance with the following code:

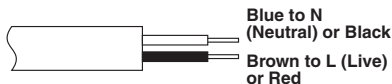

If these colours do not correspond with the terminal identifications of your plug, connect as follows:

Blue wire to terminal coded N (Neutral) or coloured black.

Brown wire to terminal coded L (Live) or coloured Red.

If in doubt — consult a competent electrician.

**WARNING: TO PREVENT FIRE OR SHOCK HAZARD, DO NOT EXPOSE THIS UNIT TO RAIN OR MOISTURE.**

## CAUTIONS:

- To prevent shock, do not open the cabinet. No user serviceable parts inside. Refer servicing to qualified personnel.
- When you are not using the AC adapter for a long period of time, it is recommended that you disconnect the power cord from AC outlet.

## NOTES:

- The rating plate and safety caution are on the bottom and/or the back of the main unit.
- The serial number plate is on the battery pack mount.
- The rating information and safety caution of the AC adapter are on its upper and lower sides.

## WARNING:

Batteries shall not be exposed to excessive heat such as direct sunshine, fire or the like.

## CAUTION:

The mains plug shall remain readily operable.

## Caution on Replaceable lithium battery

The battery used in this device may present a fire or chemical burn hazard if mistreated. Do not recharge, disassemble, heat above 100°C or incinerate.

Replace battery with Panasonic (Matsushita Electric), Sanyo, Sony or Maxell CR2025. Danger of explosion or Risk of fire if the battery is incorrectly replaced.

- Dispose of used battery promptly.
- Keep away from children.
- Do not disassemble and do not dispose of in fire.

When the equipment is installed in a cabinet or on a shelf, make sure that it has sufficient space on all sides to allow for ventilation (10 cm or more on both sides, on top and at the rear).

Do not block the ventilation holes.

(If the ventilation holes are blocked by a newspaper, or cloth etc. the heat may not be able to get out.)

No naked flame sources, such as lighted candles, should be placed on the apparatus.

When discarding batteries, environmental problems must be considered and the local rules or laws governing the disposal of these batteries must be followed strictly.

The apparatus shall not be exposed to dripping or splashing.

Do not use this equipment in a bathroom or places with water.

Also do not place any containers filled with water or liquids (such as cosmetics or medicines, flower vases, potted plants, cups etc.) on top of this unit. (If water or liquid is allowed to enter this equipment, fire or electric shock may be caused.)

Do not point the lens directly into the sun. This can cause eye injuries, as well as lead to the malfunctioning of internal circuitry. There is also a risk of fire or electric shock.

## CAUTION!

The following notes concern possible physical damage to the camera and to the user.

Carrying or holding the camera by the LCD monitor can result in dropping the unit, or in a malfunction.

Do not use a tripod on unsteady or unlevel surfaces. It could tip over, causing serious damage to the camera.

## CAUTION!

Connecting cables (Audio/Video, S-Video, etc.) to the camera and leaving it on top of the TV is not recommended, as tripping on the cables will cause the camera to fall, resulting in damage.

## CAUTION:

To avoid electric shock or damage to the unit, first firmly insert the small end of the power cord into the AC Adapter until it is no longer wobbly, and then plug the larger end of the power cord into an AC outlet.

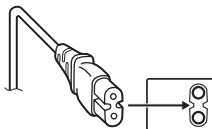

## Information for Users on Disposal of Old Equipment

### [European Union]

This symbol indicates that the electrical and electronic equipment should not be disposed as general household waste at its end-of-life. Instead, the product should be handed over to the applicable collection point for the recycling of electrical and electronic equipment for proper treatment, recovery and recycling in accordance with your national legislation.

By disposing of this product correctly, you will help to conserve natural resources and will help prevent potential negative effects on the environment and human health which could otherwise be caused by inappropriate waste handling of this product. For more information about collection point and recycling of this product, please contact your local municipal office, your household waste disposal service or the shop where you purchased the product.

Penalties may be applicable for incorrect disposal of this waste, in accordance with national legislation.

### (Business users)

If you wish to dispose of this product, please visit our web page [www.jvc-europe.com](http://www.jvc-europe.com) to obtain information about the take-back of the product.

### [Other Countries outside the European Union]

If you wish to dispose of this product, please do so in accordance with applicable national legislation or other rules in your country for the treatment of old electrical and electronic equipment.



### Attention:

This symbol is only valid in the European Union.

**DON'T** continue to operate the equipment if you are in any doubt about it working normally, or if it is damaged in any way — switch off, withdraw the mains plug and consult your dealer.

**DON'T** remove any fixed cover as this may expose dangerous voltages.

**DON'T** leave equipment switched on when it is unattended unless it is specifically stated that it is designed for unattended operation or has a standby mode. Switch off using the switch on the equipment and make sure that your family knows how to do this. Special arrangements may need to be made for infirm or handicapped people.

**DON'T** use equipment such as personal stereos or radios so that you are distracted from the requirements of road safety. It is illegal to watch television whilst driving.

**DON'T** listen to headphones at high volume, as such use can permanently damage your hearing.

**DON'T** obstruct the ventilation of the equipment, for example with curtains or soft furnishings.

Overheating will cause damage and shorten the life of the equipment.

**DON'T** use makeshift stands and NEVER fix legs with wood screws — to ensure complete safety always fit the manufacturer's approved stand or legs with the fixings provided according to the instructions.

**DON'T** allow electrical equipment to be exposed to rain or moisture.

### ABOVE ALL

- NEVER let anyone especially children push anything into holes, slots or any other opening in the case — this could result in a fatal electrical shock;
- NEVER guess or take chances with electrical equipment of any kind — it is better to be safe than sorry!

## SOME DO'S AND DON'TS ON THE SAFE USE OF EQUIPMENT

This equipment has been designed and manufactured to meet international safety standards but, like any electrical equipment, care must be taken if you are to obtain the best results and safety is to be assured.

**DO** read the operating instructions before you attempt to use the equipment.

**DO** ensure that all electrical connections (including the mains plug, extension leads and interconnections between pieces of equipment) are properly made and in accordance with the manufacturer's instructions. Switch off and withdraw the mains plug when making or changing connections.

**DO** consult your dealer if you are ever in doubt about the installation, operation or safety of your equipment.

**DO** be careful with glass panels or doors on equipment.

## Remember that this camera is intended for private consumer use only.

Any commercial use without proper permission is prohibited. (Even if you record an event such as a show, performance or exhibition for personal enjoyment, it is strongly recommended that you obtain permission beforehand.)

### Trademarks

- Manufactured under license from Dolby Laboratories. Dolby and double-D symbol are trademarks of Dolby Laboratories.



MascotCapsule is a registered trademark of HI CORPORATION in Japan.

Copyright © 2001 HI CORPORATION. All rights reserved.

- Other product and company names included in this instruction manual are trademarks and/or registered trademarks of their respective holders.

# Read This First!

## **Make a backup of important recorded data**

JVC will not be responsible for any lost data. It is recommended to copy your important recorded data to a DVD or other recording media for storage. (☞ pg. 40)

---

## **Make a trial recording**

Before the actual recording of important data, make a trial recording and play back the recorded data to check that the video and sound have been recorded correctly.

---

## **Reset the camera if it does not operate correctly**

This camera uses a microcomputer. Factors such as background noise and interference can prevent it from operating correctly. If the camera does not operate correctly, reset the camera. (☞ pg. 51)

---

## **Precautions on handling batteries**

- Be sure to use the JVC BN-VF808U/VF815U/VF823U battery packs.
  - If the camera is subjected to electrostatic discharge, turn the power off before using it again.
- 

## **If a malfunction occurs, stop using the camera immediately and consult your local JVC dealer**

- If a problem occurs when using the SD card, take the card together with the camera for repair. If one of them is not included, the cause of the malfunction cannot be diagnosed, and the camera cannot be repaired.
  - Recorded data may be erased while the camera is being repaired or inspected. Back up all data before requesting repairs or inspections.
- 

## **Because the camera may be used for demonstration in a shop, the demonstration mode is set to on by default**

To deactivate the demonstration mode, set [DEMO MODE] to [OFF]. (☞ pg. 48)

# Contents

## GETTING STARTED

<b>Accessories</b> .....	6
Attaching the Shoulder Strap .....	7
Attaching the Core Filter .....	7
<b>Index</b> .....	8
<b>Indications on LCD Monitor</b> .....	10
<b>Necessary Settings before Use</b> .....	12
Charging the Battery Pack .....	12
Language Setting .....	13
Date/Time Setting .....	13
<b>Other Settings</b> .....	14
Grip Adjustment .....	14
Lens Cover .....	14
Checking the Remaining Battery Power .....	14
Tripod Mounting .....	14
When Using an SD Card .....	15

## RECORDING

<b>Recording Files</b> .....	16
Video Recording .....	16
Still Image Recording .....	17
Zooming .....	18
LED Light .....	18
Registering Files to Events .....	19
Checking the Remaining Space on the Recording Media .....	19
<b>Manual Recording</b> .....	20
To Change to Manual Recording Mode .....	20
Program AE .....	20
Nightscope .....	21
Backlight Compensation .....	21
Spot Exposure Control .....	21
Manual Setting in Function Menu .....	22

## PLAYBACK

<b>Playing Back Files</b> .....	24
Video Playback .....	24
Still Image Playback .....	25
File Search Function .....	26
To Play Back Demonstration Files.....	27
Playback with Special Effects .....	28
<b>Watching Images on TV</b> .....	29

## EDITING/PRINTING

<b>Managing Files</b> .....	30
Deleting/Protecting Files .....	30
Viewing File Information .....	32
Changing the Event Registration of Video Files after Recording .....	32
Partial Delete (EDITED COPY) .....	33
<b>Playlists</b> .....	34
Creating Playlists .....	34
Playing Back Playlists .....	35
Other Operations of Playlists .....	36
<b>Print Setting</b> .....	37
DPOF Print Setting .....	37
Direct Printing with PictBridge Printer .....	38

## COPYING

<b>Copying Files</b> .....	40
Using a DVD Burner to Copy Files from the Camera (DVD Creation Function) .....	40
Using a VCR/DVD Recorder to Dub Files from the Camera.....	44
Copying/Moving Still Image Files .....	45

## MENU SETTINGS

<b>Changing the Menu Settings</b> .....	46
---	----

## FURTHER INFORMATION

<b>Troubleshooting</b> .....	51
<b>Warning Indications</b> .....	54
<b>Cleaning</b> .....	55
<b>Specifications</b> .....	56
<b>Cautions</b> .....	58
<b>Terms</b> .....	60

# Accessories



**AC Adapter**  
AP-V17E/14E

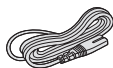

**Power Cord**  
(for AP-V14E only)

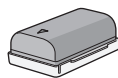

**Battery Pack**  
BN-VF808U

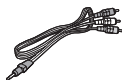

**Audio/Video Cable**



**USB Cable**  
(➡ pg. 38, 40 and PC  
OPERATION GUIDE)



**Shoulder Strap**  
(➡ pg. 7)



**CD-ROM**  
(➡ PC OPERATION  
GUIDE)



**Core Filter** (➡ pg. 7)

## NOTE

Make sure to use the provided cables for connections. Do not use any other cables.

## Attaching the Shoulder Strap

Peel off the pad and thread the end of the strap through the eyelet.

Thread the strap through the buckle, adjust its length, and use the strap guide to fix it in place.

Position the buckle near the eyelet and reattach the pad.

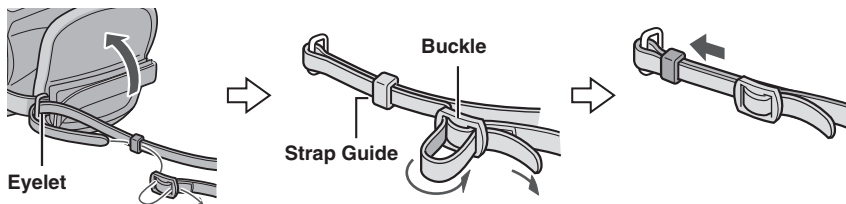

## Attaching the Core Filter

Attach the core filter to the AC adapter's DC cord. The core filter reduces interference.

**Release the stopper.**

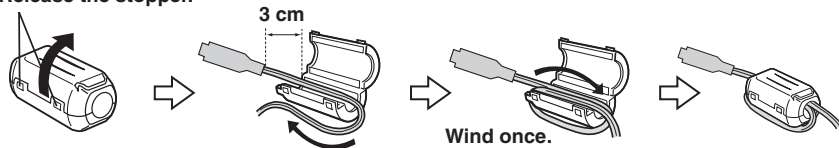

# Index

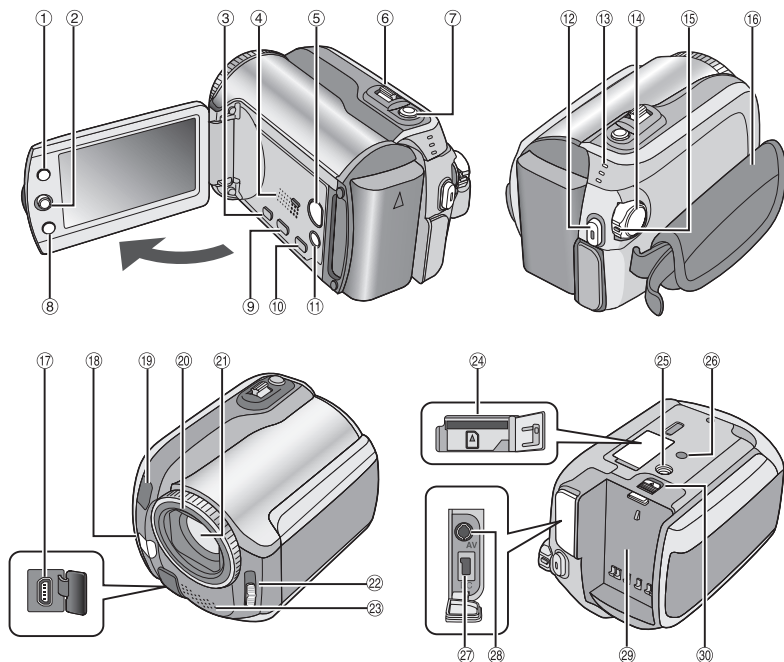

## NOTES



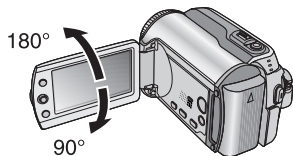









- The LCD monitor can rotate 270°.



## • Power-linked operation

You can also turn the camera on/off by opening/closing the LCD monitor during the recording mode.

- Be careful not to cover 18, 19, 21 and 23 during shooting.

- ③ Index Button [INDEX] (☞ pg. 26)/  
Remaining Space Button/Data Battery  
Button [  /  ] (☞ pg. 14, 19)
- ④ Set Lever  
Move to ^ :  
Reverse Skip (☞ pg. 24)/Up/Backlight  
Compensation [  ] (☞ pg. 21)/Spot  
Exposure Control [  ] (☞ pg. 21)  
Move to v :  
Forward Skip (☞ pg. 24)/Down/  
Change LED Light Setting [LIGHT]  
(☞ pg. 18)  
Move to < :  
Reverse Search (☞ pg. 24)/Left/  
Nightscope [NIGHT] (☞ pg. 21)  
Move to > :  
Forward Search (☞ pg. 24)/Right/  
Program AE [PROGRAM AE] (☞ pg. 20)  
Press down:  
Play/Pause (☞ pg. 24)
- ③ Menu Button [MENU] (☞ pg. 46)
- ④ Speaker (☞ pg. 24)
- ⑤ Playback/Recording Mode Switching  
Button [SELECT PLAY/REC] (☞ pg. 16)
- ⑥ Zoom Lever [W , T , Q ] (☞ pg. 18)  
Speaker Volume Control [-VOL+]  
(☞ pg. 24)
- ⑦ Still Image Shooting Button [SNAPSHOT]  
(☞ pg. 17)
- ⑧ Function Button [FUNCTION] (☞ pg. 22)
- ⑨ Direct DVD Button [DIRECT DVD]  
(☞ pg. 41 and PC OPERATION GUIDE)
- ⑩ Direct Backup Button [DIRECT BACK UP]  
(☞ PC OPERATION GUIDE)/Event Button  
[EVENT] (☞ pg. 19)
- ⑪ Auto/Manual Mode Button [AUTO]  
(☞ pg. 20)/Information Button [INFO]  
(☞ pg. 32)
- ⑫ Video Recording Start/Stop Button [REC]  
(☞ pg. 16)
- ⑬ Access/Charge Lamp [ACCESS/CHARGE]  
(☞ pg. 12)  
(Blinks when you access files or charge  
the battery. Do not turn off the power or  
remove the battery pack/AC adapter while  
accessing files.)  
Video/Still Image Mode Lamp [ ,  ]  
(☞ pg. 16, 17)
- ⑭ Power/Mode Switch [OFF (CHARGE), ON,  
MODE] (☞ pg. 12)
- ⑮ Lock Button (☞ pg. 12)
- ⑯ Grip Strap (☞ pg. 14)
- ⑰ USB (Universal Serial Bus) Connector  
[  ] (☞ pg. 38, 40 and PC OPERATION  
GUIDE)
- ⑱ LED Light (☞ pg. 18)
- ⑲ Camera Sensor
- ⑳ Lens Cover (☞ pg. 14)
- ㉑ Lens
- ㉒ Lens Cover Switch [ ,  ] (☞ pg. 14)
- ㉓ Stereo Microphone
- ㉔ SD Card Slot (☞ pg. 15)
- ㉕ Tripod Mounting Socket (☞ pg. 14)
- ㉖ Stud Hole (☞ pg. 14)
- ㉗ DC Input Connector [DC] (☞ pg. 12)
- ㉘ Audio/Video Connector [AV]
- ㉙ Battery Pack Mount (☞ pg. 12)
- ㉚ Battery Release Button [BATT.] (☞ pg. 12)

# Indications on LCD Monitor

## During both Video and Still Image Recording

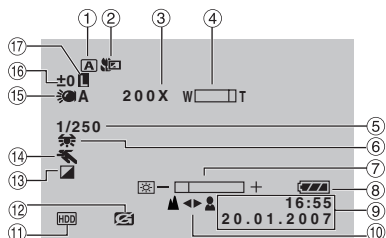

- ① Selected Operation Mode Indicator (↗ pg. 20)  
**A** : Auto Mode  
**M** : Manual Mode
- ② Tele Macro Mode Indicator (↗ pg. 23)
- ③ Approximate Zoom Ratio (↗ pg. 18)
- ④ Zoom Indicator (↗ pg. 18)
- ⑤ Shutter Speed (↗ pg. 23)
- ⑥ White Balance Indicator (↗ pg. 23)
- ⑦ Brightness Control Indicator (↗ pg. 48)
- ⑧ Battery Indicator (↗ pg. 54)
- ⑨ Date/Time (↗ pg. 13)
- ⑩ Manual Focus Adjustment Indicator (↗ pg. 22)
- ⑪ Selected Medium Indicator (↗ pg. 47, 48)
- ⑫ Drop Detection Indicator (Appears when [DROPP DETECTION] is set to [OFF].) (↗ pg. 48)
- ⑬ Effect Mode Indicator (↗ pg. 23)
- ⑭ Program AE Mode Indicator (↗ pg. 20)/  
**A** : Nightscope Indicator (↗ pg. 21)
- ⑮ LED Light Indicator (↗ pg. 18)
- ⑯ ± : Exposure Adjustment Indicator (↗ pg. 22)  
**±** : Backlight Compensation Indicator (↗ pg. 21)  
**±** : Spot Exposure Control Indicator (↗ pg. 21)
- ⑰ Iris Lock Indicator (↗ pg. 21)

## During Video Recording Only

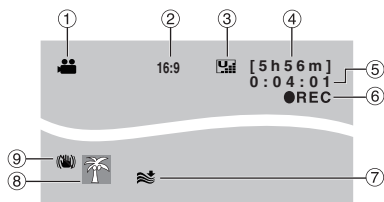

- ① Mode Indicator (↗ pg. 16)
- ② Aspect Ratio of the Image (16:9/4:3) (↗ pg. 47)
- ③ Picture Quality: **U.FINE** (ultra fine), **F.FINE** (fine), **N** (normal), **E** (economy) (↗ pg. 46)
- ④ Remaining Time (↗ pg. 16, 57)
- ⑤ Counter (↗ pg. 47)
- ⑥ ● **REC**: (Appears during recording.) (↗ pg. 16)  
**●||**: (Appears during record-standby mode.)
- ⑦ Wind Cut Indicator (↗ pg. 47)
- ⑧ Event Indicator (↗ pg. 19)
- ⑨ Digital Image Stabiliser (DIS) Indicator (Appears when [DIS] is set to [OFF].) (↗ pg. 47)

## During Still Image Recording Only

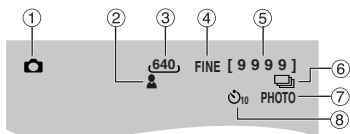

- ① Mode Indicator (↗ pg. 17)
- ② Focus Indicator (↗ pg. 22)
- ③ Image Size (↗ pg. 56)
- ④ Picture Quality: **FINE** (fine) or **STD** (standard) (↗ pg. 47)
- ⑤ Remaining Number of Shots (↗ pg. 57)
- ⑥ Continuous Shooting Mode Indicator (↗ pg. 48)
- ⑦ Shooting Indicator (↗ pg. 17)
- ⑧ Self-Timer Recording Indicator (↗ pg. 48)

## During Video Playback

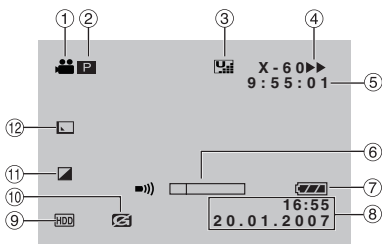

- ① Mode Indicator (↗ pg. 24)
- ② **P** : Playlist Playback Indicator (Appears when playing back a playlist.) (↗ pg. 35)
- ⓄE : Event Search Playback Indicator (Appears when playing back a video file from the event search.) (↗ pg. 27)
- ⓄD : Date Search Playback Indicator (Appears when playing back a video file from the date search.) (↗ pg. 26)
- ③ Picture Quality: (ultra fine), (fine), (normal), (economy) (↗ pg. 46)
- ④ Playback Mode (↗ pg. 24)
  - ▶ : Playback
  - || : Pause
  - ▶▶ : Forward Search
  - ◀◀ : Reverse Search
  - ||▶ : Forward Slow-Motion
  - ◀|| : Reverse Slow-Motion
 (The number on the left shows speed.)
- ⑤ Counter (↗ pg. 47)
- ⑥ Volume Level Indicator
- ⑦ Battery Indicator (↗ pg. 54)
- ⑧ Date/Time (↗ pg. 13)
- ⑨ Selected Medium Indicator (↗ pg. 47, 48)
- ⑩ Drop Detection Indicator (Appears when [DROP DETECTION] is set to [OFF].) (↗ pg. 48)
- ⑪ Effect Mode Indicator (↗ pg. 28)
- ⑫ Wipe/Fader Effect Indicator (↗ pg. 28)

## During Still Image Playback

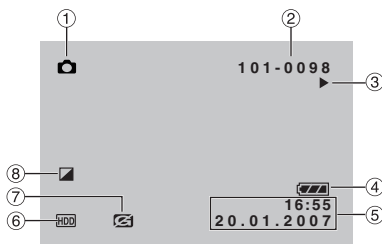

- ① Mode Indicator (↗ pg. 25)
- ② Folder/File Number
- ③ Slide Show Playback Indicator (↗ pg. 25)
- ④ Battery Indicator (↗ pg. 54)
- ⑤ Date/Time (↗ pg. 49)
- ⑥ Selected Medium Indicator (↗ pg. 47, 48)
- ⑦ Drop Detection Indicator (Appears when [DROP DETECTION] is set to [OFF].) (↗ pg. 48)
- ⑧ Effect Mode Indicator (↗ pg. 28)

### Operation guide display

The operation guide is displayed at the bottom of the screen during menu display etc.



# Necessary Settings before Use

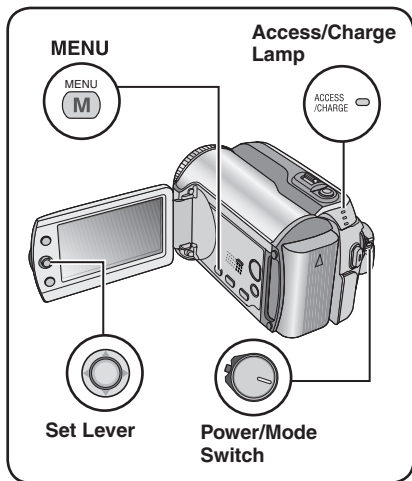

Be sure to configure the following three settings before use.

## Charging the Battery Pack

### 1 Set the power/mode switch to OFF.

Slide while pressing down the lock button.

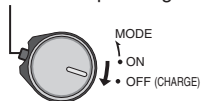

### Required charging / recording time (approx.)

The values within ( ) are the times when the LED light is on.

Battery pack	Charging time	Recording time
BN-VF808U (Provided)	1 hr. 30 min.	1 hr. 35 min. (1 hr. 30 min.)
BN-VF815U	2 hr. 40 min.	3 hr. 15 min. (3 hr. 5 min.)
BN-VF823U	3 hr. 50 min.	4 hr. 55 min. (4 hr. 35 min.)

### 2 Attach the battery pack.

Slide the battery pack down until it locks in place.

#### Bottom of the Camera

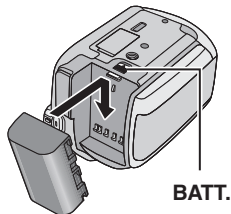

### 3 Connect the AC adapter.

#### DC Connector

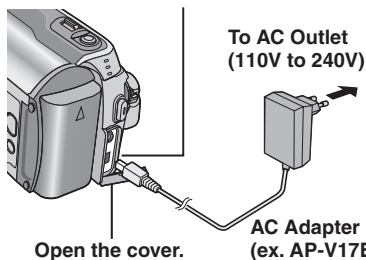

Open the cover.

AC Adapter  
(ex. AP-V17E)\*

\* If the provided AC adapter is AP-V14E, connect the power cord to the AC adapter, and plug the power cord into an AC outlet.

- The access/charge lamp blinks to indicate charging has started.
- When the lamp goes out, charging is finished. Unplug the AC adapter (or the power cord) from the AC outlet and disconnect the AC adapter from the camera.

### ■ To detach the battery pack

Slide and hold **BATT.** (→ step 2), then remove the battery pack.

### ■ To check the remaining battery power

See page 14.

#### NOTES

- You can also use the camera with just the AC adapter.
- Please do not pull or bend the AC adapter plug and cable. This may damage the AC adapter.

## Language Setting

The language on the display can be changed.

- 1 Set the power/mode switch to ON.**  
Slide while pressing down the lock button.

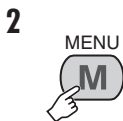
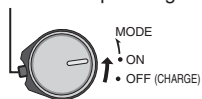

- 4 Select [GENERAL].**

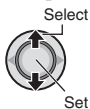

- 5 Select [LANGUAGE].**

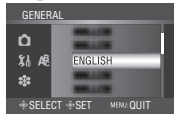
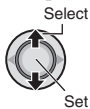

- 6 Select the desired language.**

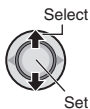

- **To return to the previous screen**  
Move the set lever to <.
- **To exit the screen**  
Press **MENU**.

## Date/Time Setting

After performing steps 1-4 (☞ left column)

- 5 Select [CLOCK ADJUST].**



- 6 Set the date and time.**



Repeat this step to input the month, day, year, hour and minute.

- 
- **To return to the previous screen**  
Move the set lever to <.
  - **To exit the screen**  
Press **MENU**.

You have now finished configuring the necessary settings.

- **To use the camera right away**  
See page 16.
- **To configure other settings**  
See page 14.

# Other Settings

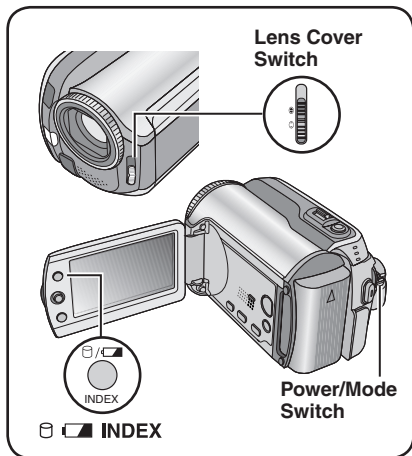

## Grip Adjustment

Open the pad and make grip adjustments.

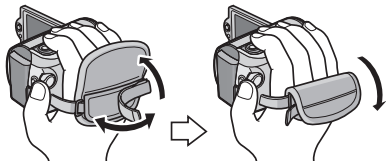

## Lens Cover

When not using the camera, close the lens cover to protect the lens.

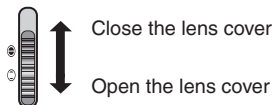

### NOTE

Do not push the lens cover strongly. Doing so may cause damage to the lens.

## Checking the Remaining Battery Power

### Preparation:

- Set the power/mode switch to **OFF**.
- Attach the battery pack.

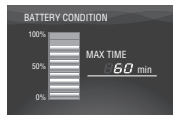

Battery information is displayed for approx. 5 seconds if the button is pressed and released quickly, and for approx. 15 seconds if the button is pressed and held for several seconds.

### NOTES

- If "COMMUNICATING ERROR" appears, there may be a problem with your battery. In such a case, consult your nearest JVC dealer.
- The recordable time display should only be used as a guide. It is displayed in 10 minute units.

## Tripod Mounting

Align the camera stud hole with the tripod stud, and the mounting socket with the screw, and then rotate the camera clockwise to mount it to the tripod.

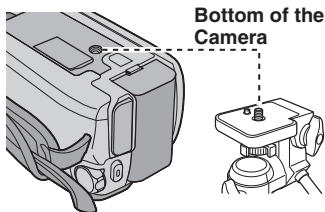

### NOTE

Do not use a tripod on unsteady or unlevel surfaces. It could tip over, causing serious damage to the camera.

## When Using an SD Card

If you want to record to an SD card, the following three operations need to be performed.

### Compatible SD cards:

**Panasonic, TOSHIBA, pqi** (still image only) and **SanDisk**. 128 MB to 4 GB.

- If other media are used, they may fail to record data correctly, or they may lose data that had already been recorded.
- For video recording, use a high-speed SD card (at least 10 MB/s).
- MultiMediaCards are not supported.

### 1 Insert an SD card

#### Preparation:

Set the power/mode switch to **OFF**.

### 1 Open the SD card cover.

Bottom of the  
Camera

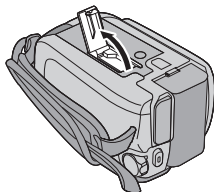

### 2 Firmly insert the card with its clipped edge first.

Clipped Edge

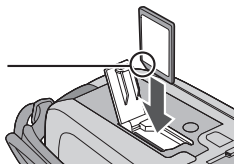

### 3 Close the SD card cover.

#### ■ To remove an SD card

Push the SD card once.

After the card comes out a little, pull it out.

### NOTES

- Insert and remove the SD card only while the power is turned off. Otherwise, data on the card may be corrupted.
- Do not touch the terminal on the reverse side of the label.

### 2 Change the recording medium

The camera is programmed to record on the built-in hard disk when it is shipped from the factory. You can change the recording medium to SD card.

Select **[REC MEDIA FOR VIDEO]** and **[REC MEDIA FOR IMAGE]** to **[SD]**. (➡ pg. 47, 48)

### 3 Format an SD card when using it for the first time

This will also ensure stable speeds and operation when accessing the SD card.

Select **[EXECUTE]** in **[FORMAT SD CARD]** to format the card. (➡ pg. 50)

# Recording Files

## Video Recording

Preparation: Set the power/mode switch to **ON**.

**1** Slide the power/mode switch to **MODE** to select  (video) mode.

The switch returns to the original position when it is released.

The  lamp on the camera lights up.

**2** Press the **PLAY/REC** button to select recording mode.

**3** Press the **REC** button to start recording.

Approximate remaining time for recording appears.

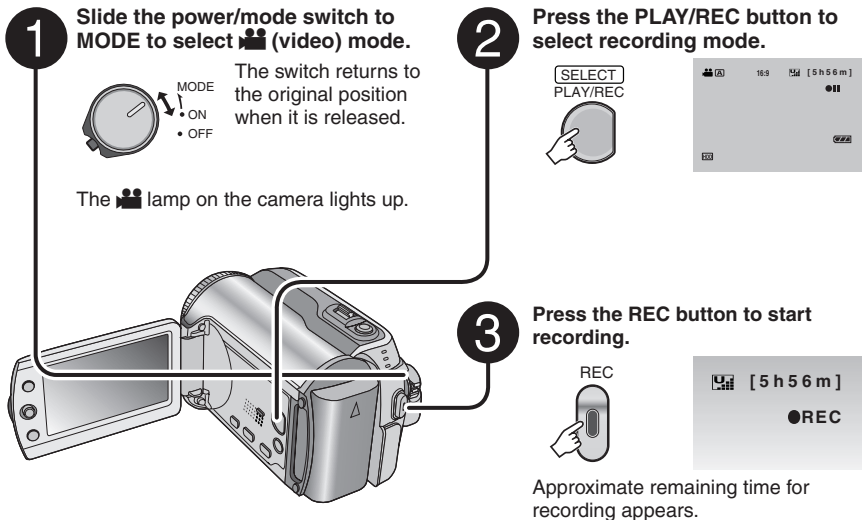

### ■ To stop recording

Press the **REC** button again.

### ■ To change the picture quality

Change the settings in [QUALITY].

( pg. 46)

### ■ To register a file to an event

See page 19.

### ■ To change the aspect ratio of the image (16:9/4:3)

Change the settings in [16:9 WIDE RECORDING]. ( pg. 47)

16:9

4:3

## NOTES

- The video recording mode is automatically selected when you turn the camera's power off and then on again.
- If the camera is not operated for 5 minutes while the power is on, it turns itself off automatically to conserve power. To turn the camera on again when using the battery pack, set the power/mode switch to **OFF**, then to **ON**. When using the AC adapter, perform any operation such as zooming.
- Video files are given the names MOV\_001.MOD to MOV\_009.MOD, MOV\_00A.MOD to MOV\_00F.MOD, and MOV\_010.MOD in order of recording.
- After recording video for 12 consecutive hours, recording stops automatically.
- A new file will be created for every 4 GB of continuous shooting.
- This camera records video in MPEG2 format compliant with SD-VIDEO format. Remember that this camera is not compatible with other digital video formats.
- Do not move or shake the camera suddenly during recording. If you do so, the sound of the hard disk drive may be recorded.

## Still Image Recording

**Preparation:** Set the power/mode switch to **ON**.

- 1** Slide the power/mode switch to **MODE** to select  (still image) mode.



The switch returns to the original position when it is released.

The  lamp on the camera lights up.

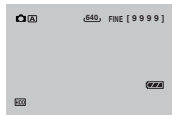

- 2** Press the **PLAY/REC** button to select recording mode.



- 3** Press and hold the **SNAPSHOT** button halfway.



The  indicator becomes green when the captured image is focused.

- **To change the picture quality**  
Change the settings in [QUALITY].  
( pg. 47)
- **To record still images continuously**  
Set [CONTINUOUS SHOOTING] to [ON].  
( pg. 48)

- 4** Press the **SNAPSHOT** button to start recording.



### NOTE

If the camera is not operated for 5 minutes while the power is on, it turns itself off automatically to conserve power. To turn the camera on again when using the battery pack, set the power/mode switch to **OFF**, then to **ON**. When using the AC adapter, perform any operation such as zooming.

# Recording Files (Continued)

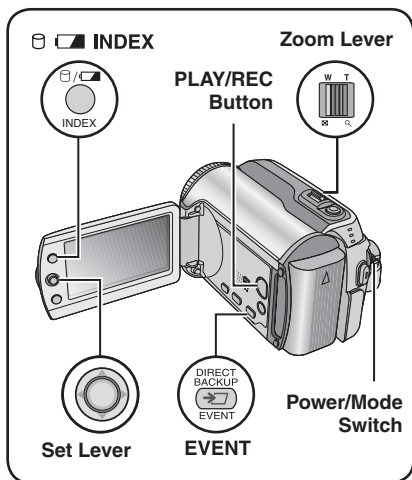

## LED Light

### Preparation:

- Slide the power/mode switch to **MODE** to select or mode.
- Press the **PLAY/REC** button to select recording mode.



Each time you move the set lever to  $\nabla$ , setting changes.



The light remains on regardless of the surrounding conditions.



The light turns on automatically when shooting in insufficient light conditions.

### No display

Disables this function.

## Zooming

### Preparation:

- Slide the power/mode switch to **MODE** to select or mode.
- Press the **PLAY/REC** button to select recording mode.

### Zoom out



### Zoom in



W: Wide angle

T: Telephoto

### Maximum Zoom Ratio (Factory-preset)

mode	mode
68X	34X

### ■ To change the maximum zoom ratio (for mode only)

Change the settings in [ZOOM]. (pg. 46)

### NOTE

Macro shooting is possible as close as approx. 5 cm to the subject when the zoom lever is set all the way to **W**.

## Registering Files to Events

– mode only

If you select an event to register the file to before starting recording, the file will be registered to the selected event, thus making the file easy to find at playback. There are up to 3 different destinations within each event (for example: BABY1, BABY2, BABY3).

### Preparation:

- Slide the power/mode switch to **MODE** to select mode.
- Press the **PLAY/REC** button to select recording mode.

1

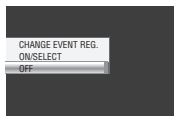

### 2 Select [ON/SELECT].

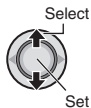

### 3 Select the event that you want to register the file to.

- To select a different destination, select [NEXT PAGE].
- To cancel the event registration, select [NON SECTION].

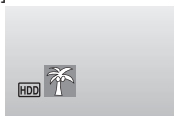
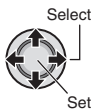

The selected event is displayed on the screen. Press the **REC** button to start recording.

### ■ To exit the screen

Press **EVENT**.

### ■ To search by event for a file to play back

See page 26.

### NOTE

Once you select to register a file to a certain event, the setting will remain even if you turn the power off. Unless you change the setting, you will register a file to the same event that you had previously selected.

## Checking the Remaining Space on the Recording Media

– mode only

### Preparation:

- Slide the power/mode switch to **MODE** to select mode.
- Press the **PLAY/REC** button to select recording mode.

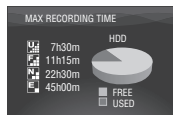

The maximum recording time is displayed for each picture quality mode ( : ULTRA FINE, : FINE, : NORMAL, : ECONOMY).

### ■ To return to the normal screen

Press the button again.

# Manual Recording

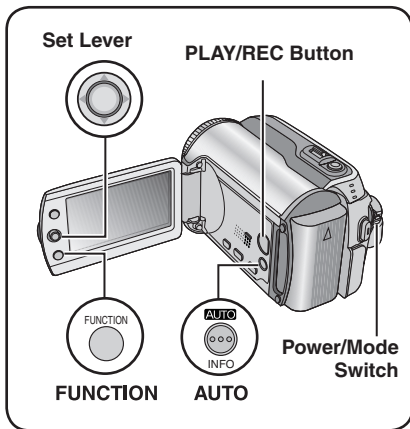

Manual recording mode enables you to set the focus and screen brightness etc. manually. You need to switch to this mode because auto recording mode, which adjusts these settings automatically, is selected by default.

## To Change to Manual Recording Mode

### Preparation:

- Slide the power/mode switch to **MODE** to select or mode.
- Press the **PLAY/REC** button to select recording mode.

### Press twice.



### To return to the auto recording mode

Press the **AUTO** button so that the **A** indicator appears.

## Program AE

You can record videos or still images with optimum brightness by adjusting the exposure and shutter speed to suit your surroundings or the subject.

**After performing "To Change to Manual Recording Mode"** (left column)

1

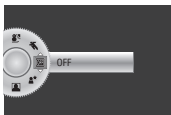

## 2 Select the desired setting.

For details on each setting, see below.



### To cancel the program AE

Select [OFF] in step 2.

### Items for program AE setting

- **SPORTS:**  
Records fast moving subjects clearly.
- **SNOW:**  
Compensates for subjects that may appear too dark when shooting in extremely bright surroundings, such as in snow.
- **SPOTLIGHT:**  
Select this when a spotlight makes a subject appear too bright.
- **TWILIGHT:**  
Makes evening scenes look more natural.

## Nightscope

The shutter speed is automatically adjusted from 1/2 to 1/250 seconds. It enables recording with low light levels in dim locations.

After performing “To Change to Manual Recording Mode” (▶ pg. 20)



### ■ To cancel nightscope

Move the set lever to < (NIGHT) so that the **A** indicator disappears.

#### NOTE

It is recommended to use the tripod (▶ pg. 14) when recording with a slow shutter speed.

## Backlight Compensation

Backlight compensation brightens the subject by increasing the exposure.

After performing “To Change to Manual Recording Mode” (▶ pg. 20)



### ■ To cancel backlight compensation

Move the set lever to ^ (B) twice so that the **B** indicator disappears.

## Spot Exposure Control

Use this function when backlight compensation does not work well, or to adjust the brightness in the desired spot.

After performing “To Change to Manual Recording Mode” (▶ pg. 20)

### 1 Move twice.



### 2 Select the desired spot metering area frame.

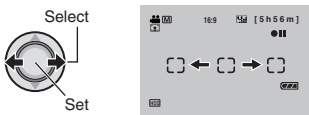

### ■ To lock the exposure

After you finish configuring the setting, press and hold the set lever for more than 2 seconds. The **L** indicator appears.

### ■ To cancel spot exposure control

Move the set lever to ^ (B) once so that the **L** indicator disappears.

# Manual Recording (Continued)

## Manual Setting in Function Menu

You can use manual recording functions easily by selecting items in the function menu.

After performing “To Change to Manual Recording Mode” (pg. 20)



### 2 Select the desired menu.

For details on each menu, see below.

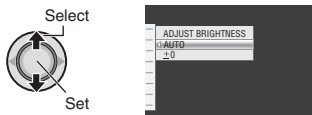

### 3 Select the desired setting.

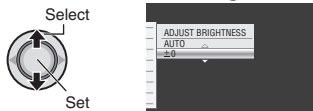

Depending on the kind of settings you select, you can set the value by moving the set lever to  $\wedge$  /  $\vee$  after selecting.



The menu disappears and the indicator for the set function appears.











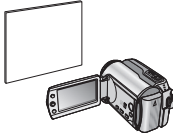

#### ■ To return to the previous screen

Move the set lever to  $\leftarrow$ .

#### ■ To exit the screen

Press **FUNCTION**.

Menus	Settings: [ ] = Factory-preset
<b>FOCUS</b> Adjusts the focus.	<b>[AUTO]:</b> The focus is adjusted automatically. <b>▲ ◀ ▶ ■:</b> Adjusts the focus manually. Move the set lever to $\leftarrow$ / $\rightarrow$ to set the focus. (When zooming, the subject will not go out of focus if you adjust the focus at the telephoto (T) side before zooming to the wide-angle (W) side.)
<b>ADJUST BRIGHTNESS</b> Adjusts the brightness.	<b>For ■ mode</b> <b>[AUTO]:</b> The brightness is adjusted automatically. <b>-6 to +6:</b> Corrects the brightness within this range in increments of 1. Move the set lever to $\wedge$ / $\vee$ to set the value. <b>For ■ mode</b> <b>[±0]:</b> The brightness is not adjusted. <b>-2.0 to +2.0 (EV):</b> Corrects the brightness within this range in increments of 1/3EV. Move the set lever to $\wedge$ / $\vee$ to set the value. <b>■ To lock the exposure</b> When the menu disappears after you finish configuring the setting, press and hold the set lever for more than 2 seconds. The ■ indicator appears.

Menus	Settings: [ ] = Factory-preset
<p><b>SHUTTER SPEED</b> A fast shutter speed can freeze the motion of a fast-moving subject, and a slow shutter speed can blur the subject to give the impression of motion.</p>	<p>[AUTO]: The shutter speed is adjusted automatically.  <b>1/2 to 1/4000 (For  mode) /</b>  <b>1/2 to 1/500 (For  mode):</b>            The smaller the value, the faster the shutter speed. Move the set lever to ^ / v to set the value.</p> <p><b>NOTE</b> It is recommended to use the tripod ( pg. 14) when recording with a slow shutter speed.</p>
<p><b>WB</b> Adjusts the white balance to achieve the optimum colours for the amount of light in your surroundings during recording.</p>	<p><b>A [AUTO]:</b> White balance is adjusted automatically.  <input checked="" type="checkbox"/> <b>MWB:</b> Adjusts the white balance manually depending on the light source.</p> <ol style="list-style-type: none"> <li>1) Hold a sheet of plain white paper in front of the subject so that the white paper fills the screen.</li> <li>2) Press and hold the set lever until the  indicator starts blinking then stops blinking.</li> </ol>  <p> <b>FINE:</b> When shooting outdoors on a sunny day.   <b>CLOUD:</b> When shooting outdoors on a cloudy day.   <b>HALOGEN:</b> When a video light or similar type of lighting is used.</p>
<p><b>EFFECT</b> Enables you to record videos or still images with special effects.</p>	<p> <b>[OFF]:</b> No effect is used.  <input checked="" type="checkbox"/> <b>SEPIA:</b> The image has a brownish tint like old photos.      B/W <b>MONOTONE:</b> The image becomes black and white like old movies.   <b>CLASSIC FILM*:</b> This effect skips frames to give images of an old movie atmosphere.   <b>STROBE*:</b> The image looks like a series of consecutive snapshots.      * Not available in  mode.</p>
<p><b>TELE MACRO</b> Enables you to shoot a subject as large as possible at a distance of approx. 40 cm.</p>	<p> <b>[OFF]:</b> Disables the function.  <input checked="" type="checkbox"/> <b>ON:</b> Activates the function.</p>

# Playing Back Files

## Video Playback

**1** Slide the power/mode switch to **MODE** to select **VIDEO** (video) mode.



The switch returns to the original position when it is released.

The **VIDEO** lamp on the camera lights up.

**2** Press the **PLAY/REC** button to select playback mode.



The index screen for videos appears.

**3** Move the set lever to **^**/**v**/**<**/**>** to select the desired file, then press down.



### ■ To return to the index screen

Press **INDEX**.

### ■ To watch on TV

See page 29.

### ■ To turn the date display on/off

Change the settings in [DATE/TIME]. (→ pg. 49)

### ■ To check the file information

Press **INFO** when playback is paused. (→ pg. 32)

### Operations during Playback

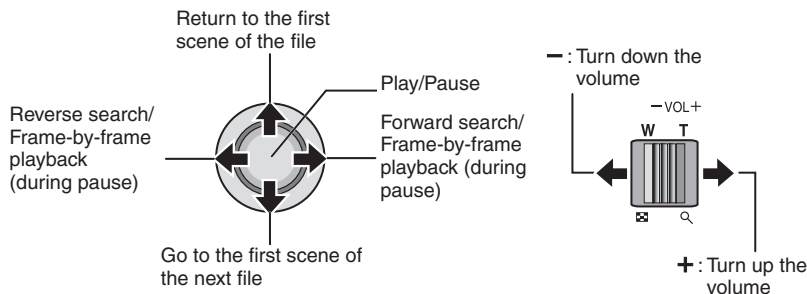

During forward reverse search, moving the set lever to **<**/**>** alters the search speed (maximum 60x).

## Still Image Playback

- 1** Slide the power/mode switch to **MODE** to select (still image) mode.



The switch returns to the original position when it is released.

The lamp on the camera lights up.

- 2** Press the **PLAY/REC** button to select playback mode.



The index screen for still images appears.

- 3** Move the set lever to **^ / \ / < / >** to select the desired file, then press down.



### ■ To return to the index screen

Press **INDEX**.

### ■ To watch on TV

See page 29.

### ■ To turn the date display on/off

Change the settings in [DATE/TIME]. (pg. 49)

### ■ To check the file information

Press **INFO**. (pg. 32)

### Operations during Playback

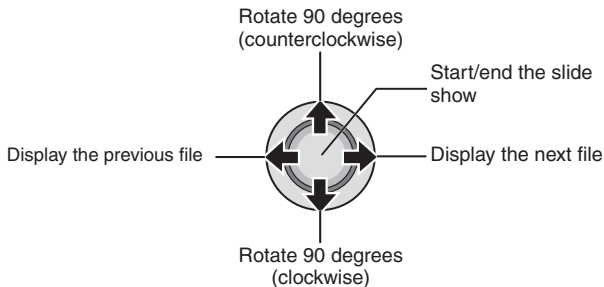

During the slide show, moving the set lever to **^ / \** changes the playback order.

# Playing Back Files (Continued)

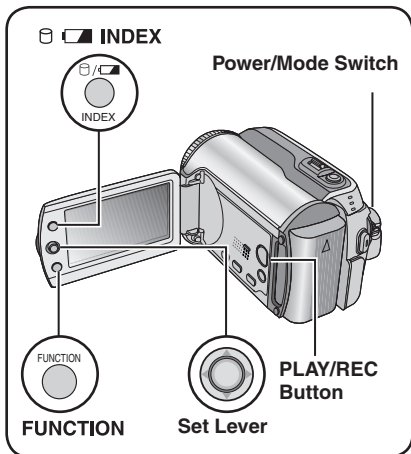

## File Search Function

You can switch the index screen to the date index screen or event screen for the convenient file search.

The event screen can be used in mode. It cannot be used in mode.

### Date Index Screen

You can search the desired file by the recording date.

#### Preparation:

- Slide the power/mode switch to **MODE** to select or mode.
- Press the **PLAY/REC** button to select playback mode.

1



## 2 Select the recording date.



## 3 Select the file you want to play back.



- **To return to the index screen**  
Press the **INDEX** button.

### Event Screen – mode only

You can search the desired file by the event that you registered the file to when recording. (pg. 19) After searching by the event, you can search by the recording date to narrow down the search.

#### Preparation:

- Slide the power/mode switch to **MODE** to select mode.
- Press the **PLAY/REC** button to select the playback mode.

## 1 Press twice.



## 2 Select the event.

To move to the next page, select [NEXT PAGE].

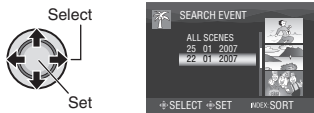

## 3 Select the recording date.

To display all the files, select [ALL SCENES].

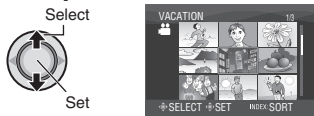

## 4 Select the file you want to play back.



### ■ To return to the index screen

Press the **INDEX** button.

### ■ To change the event registration of a file

See page 32.

## To Play Back Demonstration Files

– mode only

Video files that are used for demonstration in a shop may be recorded on the camera you purchased. These files are saved to the [EXTMOV] folder and can be played back by the following operations.

### Preparation:

- Slide the power/mode switch to **MODE** to select mode.
- Press the **PLAY/REC** button to select playback mode.

1

FUNCTION

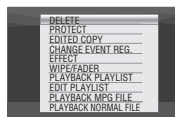

## 2 Select [PLAYBACK MPG FILE].

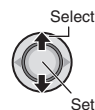

## 3 Select the file you want to play back.

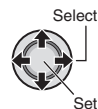

### ■ To exit the screen

Press **FUNCTION**.

### ■ To return to the normal file playback mode

Select [PLAYBACK NORMAL FILE] in step 2.

# Playing Back Files (Continued)

## Playback with Special Effects

### Wipe or fader effects

Add effects at the beginning and end of videos. These effects cannot be set for still images.

### Playback effects

Add effects that, for example, alter the colour tones of images.

#### Preparation:

- Slide the power/mode switch to **MODE** to select or mode.
- Press the **PLAY/REC** button to select the playback mode.

ex.) Set [EFFECT] to [SEPIA].

- FUNCTION**
- 2 Select [WIPE/FADER] ( mode only) or [EFFECT].**



- 3 Select a desired effect.**  
For details on each effect, see right column.



- 4 Select the file you want to play back.**



■ **To exit the screen**  
Press **FUNCTION**.

■ **To turn off the effect**  
Select [OFF] in step **3**.

## ■ Items for WIPE/FADER setting

- **FADER:WHITE:**  
Fade in or out with a white screen.
- **FADER:BLACK:**  
Fade in or out with a black screen.
- **FADER:B.W:**  
Fade in to a color screen from a black and white screen, or fade out in the opposite way.
- **WIPE:CORNER:**  
Wipe in on a black screen from the upper right to the lower left corner, or wipe out in the opposite way.
- **WIPE:WINDOW:**  
The scene starts in the center of a black screen and wipes in toward the corners, or wipes out in the opposite way.
- **WIPE:SLIDE:**  
Wipe in from right to left, or wipe out in the opposite way.
- **WIPE:DOOR:**  
Wipe in as the two halves of a black screen open to the left and right revealing the scene, or wipe out in the opposite way.
- **WIPE:SCROLL:**  
The scene wipes in from the bottom to the top of a black screen, or wipes out in the opposite way.
- **WIPE:SHUTTER:**  
Wipe in from the center of a black screen toward the top and bottom, or wipe out in the opposite way.

## ■ Items for EFFECT setting

- **SEPIA:**  
The image is given a brownish tint like an old photo.
- **MONOTONE:**  
The image becomes black and white like an old movie.
- **CLASSIC FILM\*:**  
The image is given an old movie atmosphere by the effect of skipping frames.
- **STROBE\*:**  
The image looks like a series of consecutive snapshots.  
\* Not available in mode.

# Watching Images on TV

## Preparation:

Turn off all units.

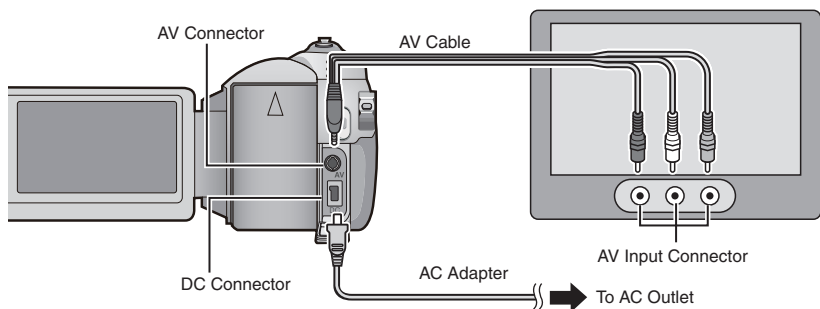

## NOTE

This camera is designed to be used with PAL-type colour television signals. It cannot be used with a television of a different standard.

- 1 Turn on the camera and the TV.
- 2 Set the TV to its VIDEO mode.
- 3 (Only when connecting the camera to the VCR/DVD recorder)  
Turn on the VCR/DVD recorder, and set the VCR/DVD recorder to its AUX input mode.
- 4 Start playback on the camera. (☞ pg. 24, 25)

## ■ If the aspect ratio of the image is not correct as shown right

Change the settings in [SELECT TV TYPE].  
(☞ pg. 49)

## ■ To display camera's on-screen display on TV

Set [DISPLAY ON TV] to [ON]. (☞ pg. 49)

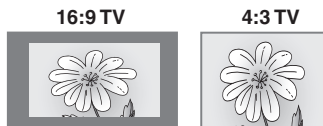

# Managing Files

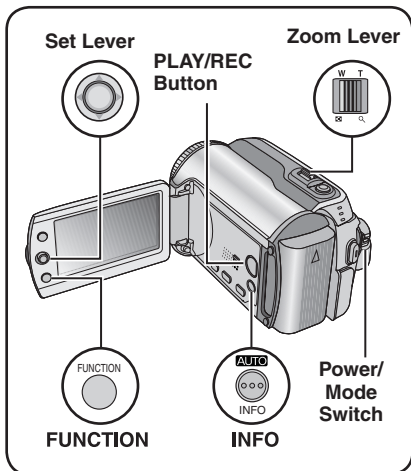

## CAUTION

Do not remove the recording medium or perform any other operation (such as turning off the power) while accessing files. Also, be sure to use the provided AC adapter, as the data on the recording medium may be corrupted if the battery becomes exhausted during operation. If the data on the recording medium becomes corrupted, format the recording medium. (▶ pg. 50)

## Deleting/Protecting Files

- Protected files cannot be deleted. To delete them, release the protection first.
- Once files are deleted, they cannot be restored. Check files before deleting.
- For an SD card, you can use the write/erase protection tab to set protection. To protect all the files, slide the tab to the "LOCK" position.

Write/erase protection tab



## Preparation:

- Slide the power/mode switch to **MODE** to select or mode.
- Press the **PLAY/REC** button to select playback mode.

## ex.) Performing [DELETE].

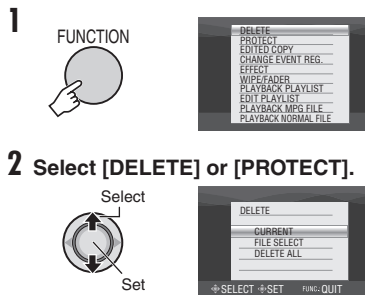

## Deleting/Protecting the Currently Displayed File

### After performing steps 1-2

### 3 Select [CURRENT].



You can select the previous or next file by moving the set lever to </>.

### 4 Select [EXECUTE].



- **To exit the screen Press FUNCTION.**

## Selecting and Deleting/Protecting Files

After performing steps 1-2 (☞ pg. 30)

### 3 Select [FILE SELECT].



### 4 Select the desired file.



- The or mark appears on the file. To select other files, repeat this step.
- If you slide the zoom lever towards **T**, the preview screen is displayed. Sliding the zoom lever towards **W** returns to the index screen.

### 5 FUNCTION



### 6 Select [EXECUTE AND QUIT] (when performing [DELETE]) or [QUIT] (when performing [PROTECT]).



- **To exit the screen**  
Press **FUNCTION**.

## Deleting/Protecting All Files

After performing steps 1-2 (☞ pg. 30)

### 3 Select [DELETE ALL] or [PROTECT ALL].



### 4 Select [EXECUTE].





- **To exit the screen**  
Press **FUNCTION**.

- **To release protection**  
Select the protected file in step 4 ("Selecting and Deleting/Protecting Files" ☞ left column).
- **To release protection of all files**
  - 1) In step 3, select [CANCEL ALL], then press down the set lever.
  - 2) Move the set lever to  $\wedge$  /  $\vee$  to select [EXECUTE], then press down.

# Managing Files (Continued)

## Viewing File Information

### Preparation:

- For  mode: Pause the playback. Alternatively, select the file on the index screen.
- For  mode: Play back the still image. Alternatively, select the file on the index screen.

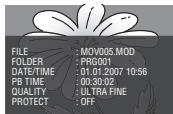

### ● FILE:

File name

### ● FOLDER:

Folder name

### ● DATE/TIME:

Date and time of the recording

### ● PB TIME (for video files):

Playback time (length of the file)

### ● SIZE (for still images):

Image size (⇨ pg. 47)

### ● QUALITY:

Image quality (⇨ pg. 46, 47)

### ● PROTECT:

File protection status (⇨ pg. 30)

### ■ To turn off the file information display

Press INFO again.

## Changing the Event Registration of Video Files after Recording

–  mode only

### Preparation:

- Slide the power/mode switch to **MODE** to select  mode.
- Press the **PLAY/REC** button to select playback mode.

1

FUNCTION

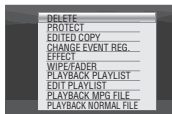

### 2 Select [CHANGE EVENT REG.].

Select



Set



### 3 Select a new event to register the file to.

- To move to the next page, select [NEXT PAGE].
- To cancel the event registration, select [NON SECTION].

Select



Set



### 4 Select the file you want to register.

Select



Set

- The  mark appears on the file. To select other files, repeat this step.
- If you slide the zoom lever towards **T**, the preview screen is displayed. Sliding the zoom lever towards **W** returns to the index screen.

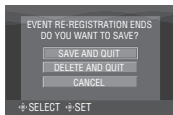
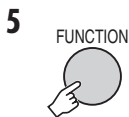

## 6 Select [SAVE AND QUIT].

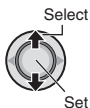

- To exit the screen  
Press **FUNCTION**.

## Partial Delete (EDITED COPY) — mode only

You can divide the selected video file into two, and make a copy of the desired section as a new video file.

### Preparation:

- Slide the power/mode switch to **MODE** to select mode.
- Press the **PLAY/REC** button to select playback mode.

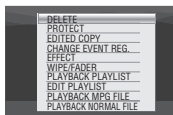
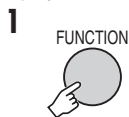

## 2 Select [EDITED COPY].

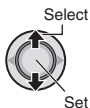

## 3 Select the desired file.

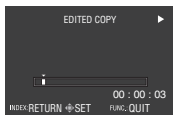

Playback starts.

## 4 Set the point at which you want to divide the file.

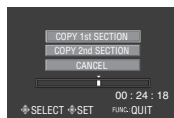

## 5 Select the file you want to copy.

- **[COPY 1st SECTION]:**  
Copy the section before the division point.
- **[COPY 2nd SECTION]:**  
Copy the section after the division point.



When copying is finished, the copied file is added to the index screen.

- To exit the screen  
Press **FUNCTION**.

### NOTE

When playing back the copied file, the recording date of the original file is displayed. Meanwhile, the date when you copied is displayed on the file information display. (→ pg. 32)

# Playlists – mode only

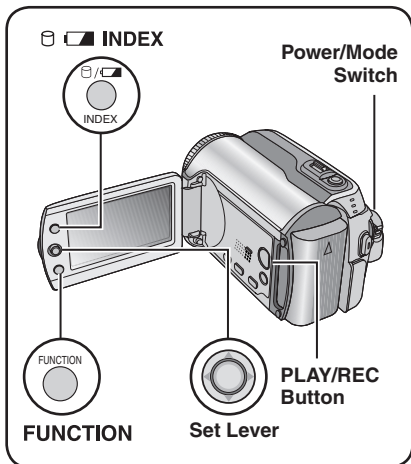

It is a list that enables you to organise recorded videos in order of preference.

## Preparation:

- Slide the power/mode switch to **MODE** to select  mode.
- Press the **PLAY/REC** button to select playback mode.

## Creating Playlists



## 2 Select [EDIT PLAYLIST].



## 3 Select [NEW LIST].



## 4 Select an item and display files.

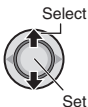

- **[IMPORT FROM EVENT]:**  
Search for an event and display the corresponding files listed by recording date.  
Move the set lever to  $\wedge / \vee / \langle / \rangle$  to select the event, then press down.
- **[IMPORT FROM DATE]:**  
Display all the files in the medium listed by recording date.
- **[ALL SCENES]:**  
Display all files individually.

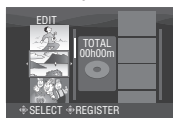

## 5 Select the file to add to playlist.



To preview scenes, move the set lever to  $\wedge / \vee$  to select the file and press the **INDEX** button. When the index screen of individual scenes appears, move the set lever to  $\wedge / \vee / \langle / \rangle$  to select the file, then press down.  
To return to previous screen, press **INDEX**.

## 6 Select the insertion point.



- To add other files, repeat steps **5** and **6**.
- To delete a registered scene, move the set lever to  $\wedge$  /  $\vee$  to select the registered file, then press down.

## 7



## 8 Select [SAVE AND QUIT].



- **To exit the screen**  
Press **FUNCTION**.

### NOTES

- A maximum of 99 playlists can be created.
- Each playlist can consist of a maximum of 99 scenes.
- If you delete the original files, the corresponding files are also deleted from the playlist.

## Playing Back Playlists

### 1

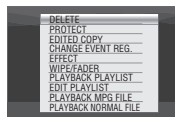

### 2 Select [PLAYBACK PLAYLIST].

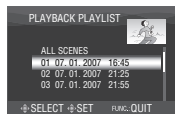

### 3 Select the playlist that you want to play back.

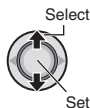

- **To exit the screen**  
Press **FUNCTION**.
- **To stop playback**  
Press down the set lever.
- **To return to the normal file playback mode**  
Select [PLAYBACK NORMAL FILE] in step **2**.
- **To play back from the desired scene**
  - 1) In step **2**, press the **INDEX** button. (The index screen for playlist appears.)
  - 2) Move the set lever to  $\wedge$  /  $\vee$  /  $\langle$  /  $\rangle$  to select the desired scene, then press down.
- **When dubbing playlists using a VCR/DVD recorder** (pg. 44)  
Play back playlists by performing the following operations.
  - 1) After performing steps **1-2**, move the set lever to  $\triangleright$ .
  - 2) Move the set lever to  $\wedge$  /  $\vee$  to select [START PLAYBACK], then press down. (A black screen is displayed for five seconds at the first and the last scene.)

# Playlists – mode only (Continued)

## Other Operations of Playlists

You can perform additional editing and delete files in a created playlist.

### Preparation:

Perform steps **1-2**. ( pg. 34)

### Adding/Deleting Files in Playlist

- 3** Move the set lever to  $\wedge / \vee$  to select [EDIT], then press down.
- 4** Move the set lever to  $\wedge / \vee$  to select the playlist you want to edit, then press down.  
To add or delete files, follow the steps **5** to **8** in “Creating Playlists”. ( pg. 34)

### Changing Playlist Names

The default name of a playlist is its creation date and time.

- 3** Move the set lever to  $\wedge / \vee$  to select [RENAME], then press down.
- 4** Move the set lever to  $\wedge / \vee$  to select the desired playlist, then press down.
- 5** Move the set lever to  $\wedge / \vee / \langle / \rangle$  to select the desired letter, then press down.
  - Repeat this process to complete the name.
  - You can change the character types (capital letters, small letters or marks) by selecting [A/a/@].
  - To correct a letter, select [ $\leftarrow$ ] or [ $\rightarrow$ ] and press down the set lever to move the cursor to the letter, then select [CLEAR] and press down the set lever.
- 6** Move the set lever to  $\wedge / \vee / \langle / \rangle$  to select [ $\leftarrow$ ], then press down.

### Deleting Playlist

Original files are not deleted even if you delete the playlist.

- 3** Move the set lever to  $\wedge / \vee$  to select [DELETE], then press down.
- 4** Move the set lever to  $\wedge / \vee$  to select a playlist you want to delete.  
To delete all playlists at once, select [DELETE ALL].
- 5** Press down the set lever.
- 6** Move the set lever to  $\wedge / \vee$  to select [EXECUTE], then press down.

# Print Setting – mode only

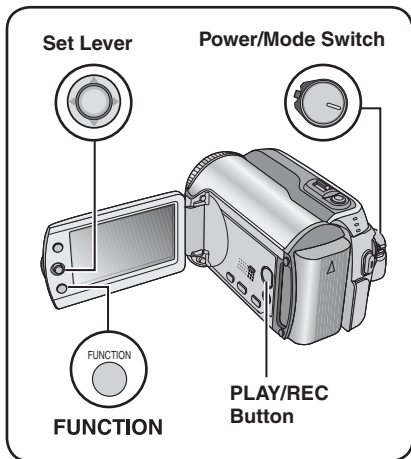

## Setting Files Individually

After performing steps 1-2

### 3 Select [SELECT IMAGES].

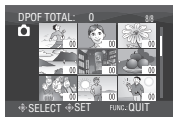

### 4 Select the desired file.



If you slide and hold the zoom lever towards **T**, the preview screen of the still image is displayed.

### 5 Select the number of prints. (max. 15 prints)

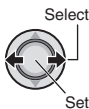

To set print information for other images, repeat steps 4 and 5. (You can set up to 999 files.)

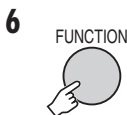

#### ■ To exit the screen

Press **FUNCTION**.

#### ■ To cancel the selection

Set the number of prints to "00" in step 5.

#### ■ To confirm DPOF settings

In step 3, move the set lever to  $\wedge$  /  $\vee$  to select [CHECK SETTINGS], then press down.

- If necessary, change the number of prints for the desired file by following steps 4 and 5.

#### ■ To reset DPOF settings

- 1) In step 3, move the set lever to  $\wedge$  /  $\vee$  to select [RESET], then press down.
- 2) Move the set lever to  $\wedge$  /  $\vee$  to select [EXECUTE], then press down.

## DPOF Print Setting

This camera is compatible with DPOF (Digital Print Order Format). You can set which images to be printed and the number of prints with this camera. This feature is useful to print with a DPOF-compatible printer or for taking the recording medium to a photo lab for printing.

### Preparation:

- Slide the power/mode switch to **MODE** to select  mode.
- Press the **PLAY/REC** button to select playback mode.

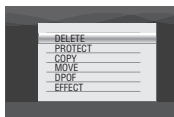
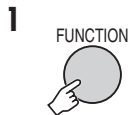

### 2 Select [DPOF].



# Print Setting – mode only (Continued)

## Setting All Files Together (One Print for Each)

After performing steps 1-2 ( pg. 37)

### 3 Select [ALL1].



### 4 Select [EXECUTE].



■ **To exit the screen**  
Press **FUNCTION**.

■ **To confirm DPOF settings**

In step 3, move the set lever to ^ / v to select [CHECK SETTINGS], then press down.

- If necessary, change the number of prints for the desired file by following steps 4 and 5. ( pg. 37)

■ **To reset DPOF settings**

- 1) In step 3, move the set lever to ^ / v to select [RESET], then press down.
- 2) Move the set lever to ^ / v to select [EXECUTE], then press down.

## Direct Printing with PictBridge Printer

If your printer is compatible with PictBridge, still images can be printed easily by connecting the camera directly to the printer with the USB cable. DPOF setting can also be used. ( pg. 37)

### Preparation:

Set the power/mode switch to **OFF**.

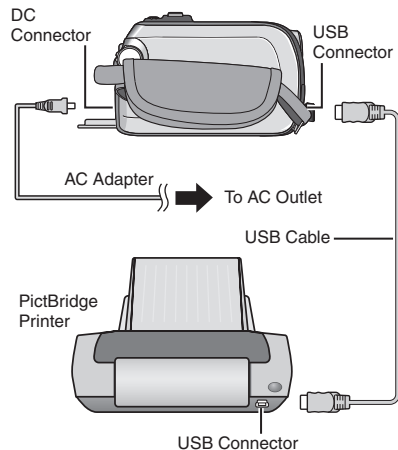

### 1 Set the power/mode switch to ON.

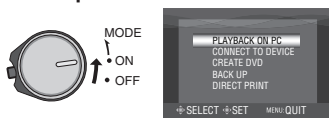

### 2 Select [DIRECT PRINT].



## To Print by Selecting a Still Image

After performing steps 1-2 (☞ pg. 38)

### 3 Select [SELECTED PRINT].



### 4 Select the desired Image.



### 5 Move the set lever to ^ / v to select menus and < / > to select settings.

- **[NUMBER OF PRINTS]:**  
The number of prints can be set from 1 to 99.
- **[DATE]:**  
Set whether to print the date and time.



### 6 Select [PRINT].



#### ■ To stop printing after printing starts

- 1) Press down the set lever.
- 2) Move the set lever to ^ / v to select [EXECUTE], then press down.

## To Print Using the DPOF Settings

If the printer is compatible with DPOF, you can use the DPOF settings. (☞ pg. 37)

After performing steps 1-2 (☞ pg. 38)

### 3 Select [DPOF PRINT].



### 4 Select [PRINT].



#### ■ To stop printing after printing starts

- 1) Press down the set lever.
- 2) Move the set lever to ^ / v to select [EXECUTE], then press down.

#### ■ To confirm the DPOF setting

In step 4, move the set lever to ^ / v to select [CHECK SETTINGS], then press down. To return to the previous screen, press **FUNCTION**.

#### NOTES

- If the printer is not recognised, disconnect the USB cable, then reconnect it.
- You cannot return to the previous screen while operating Direct print. If you want to redo the operation, remove the USB cable, switch off the camera's power, and start the operation again from the beginning.

# Copying Files

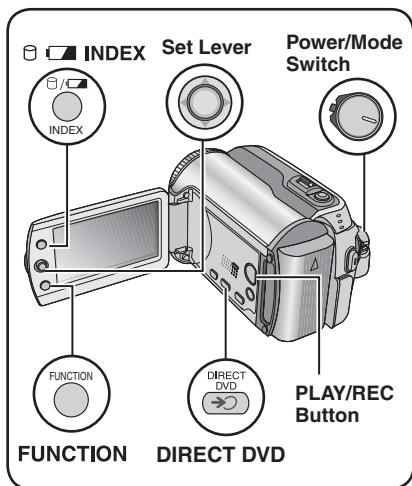

## Using a DVD Burner to Copy Files from the Camera (DVD Creation Function)

### Supported discs: 12cm DVD-R, DVD-RW

- Regarding DVD-R discs, only unused DVD-R discs can be used. Regarding DVD-RW discs, used DVD-RW discs can also be used, but they need to be formatted before recording. Formatting a disc deletes all content recorded on the disc up until that time.
- Dual-layer discs cannot be used.

### Regarding finalisation after copying

The disc is automatically finalised so that it can be played on other devices. After finalising, the disc is a play-only disc, so no more files can be added.

### Preparation:

Set the power/mode switch to **OFF**.

## Types of Copying and Connectable Device

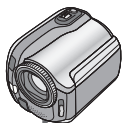

### The Camera

You can copy still images between the HDD and SD card with this camera alone. (➡ pg. 45)



### DVD Burner (CU-VD10/CU-VD20)

You can copy video files recorded on this camera onto DVD discs. (➡ right column)



### VCR/DVD Recorder

You can dub video files recorded on this camera onto DVD discs. (➡ pg. 44)

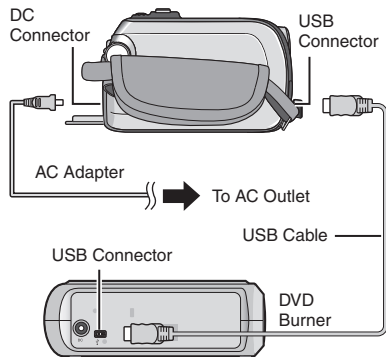

## Copying Only the Newly Taken Video Files

Files that have never been copied to the DVD discs are automatically selected and copied.

### 1 Set the power/mode switch to ON.

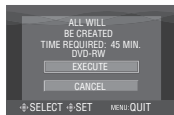
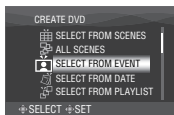

### 3 Select [EXECUTE].

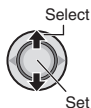

- The DVD disc begins to be created. When [COMPLETED] appears, press down the set lever to complete the operation.
- When [COMPLETED. CHANGE DISC] appears, change the disc. The second DVD disc begins to be created.
- To cancel the DVD creation, select [CANCEL].

#### ■ To exit the screen

Press **MENU**, then move the set lever to  $\wedge / \vee$  to select [EXECUTE] and press down.

## Selecting and Copying Video Files

After performing step 1 (☞ left column)

### 2 Select an item and display the DVD Creation List for the files to be copied.



- **[SELECT FROM EVENT]:** Search for an event and display the corresponding files listed by recording date. Move the set lever to  $\wedge / \vee / \langle / \rangle$  to select the event, then press down.
- **[SELECT FROM DATE]:** Display the files recorded on selected dates listed by recording date. Move the set lever to  $\wedge / \vee$  to select the recording date, then press down.
- **[SELECT FROM PLAYLIST]:** Register a created playlist. (☞ pg. 34) Playlists are displayed in a list in the selection order.
  - 1) Move the set lever to  $\wedge / \vee$  to select the desired list, then press down. To select other lists, repeat this process.
  - 2) Move the set lever to  $>$  twice.
- **[CREATE DUPLICATE]:** Create a DVD disc identical to the one created last time. The last creation date is displayed. (Up to 20 files) Move the set lever to  $\wedge / \vee$  to select the date, then press down.
- **[SELECT FROM SCENES]:** Register a file individually. Files are displayed in a list in the selection order.
  - 1) Move the set lever to  $\wedge / \vee$  to select the desired file, then press down. To select other files, repeat this process.
  - 2) Move the set lever to  $>$  twice.
- **[ALL SCENES]:** Display all files individually.

**Make sure to read "Disc number"** (☞ pg. 42) before proceeding to the next procedure.

Continued on next page

# Copying Files (Continued)

## 3 Select the desired disc number.



- If you select [ALL], all discs in the list are created.
- To preview scenes, move the set lever to  $\wedge / \vee$  to select the file and press the **INDEX** button. When the index screen of individual scenes appears, move the set lever to  $\wedge / \vee / \langle / \rangle$  to select the file, then press down.
- To return to previous screen, press **INDEX**.
- $\odot$  mark shows that the disc is created already.

## 4

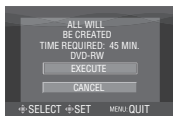

## 5 Select [EXECUTE].



- The DVD disc begins to be created. When [COMPLETED] appears, press down the set lever to complete the operation.
- When [COMPLETED. CHANGE DISC] appears, change the disc. The second DVD disc begins to be created.
- To cancel the DVD creation, select [CANCEL].

### ■ To exit the screen

Press **MENU**, then move the set lever to  $\wedge / \vee$  to select [EXECUTE] and press down.

### ■ To check whether the DVD disc was created properly

In step 2 (pg. 41), move the set lever to  $\wedge / \vee$  to select [PLAY DVD], then press down. To return to the previous screen, press the **INDEX** button.

### ■ Disc number

Disc number shows the number of DVD discs you can create. The dubbing range of each disc is automatically allocated, presuming that all the files are to be dubbed from the first one on the list. This dubbing range cannot be changed. ex.) "DVD1" records 2 files, "01.01.2007" and "15.01.2007".

ALL	
DVD1	01.01.2007 12:04
	15.01.2007 12:15
DVD2	01.02.2007 12:04
	08.02.2007 12:15

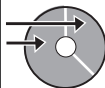

## ■ Title and chapter of created DVD

Each recording date becomes one title in a created DVD and each scene recorded in a same day becomes one chapter in the title.

### 10.01.2007: records file 1 and 2.



### 11.01.2007: records file 3 and 4.



Create a DVD

Title

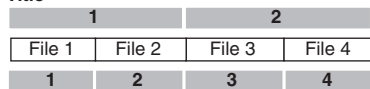

Chapter

## ■ Menu for disc playback

When you play back the created DVD disc on a DVD player or other devices, the following top menu will be displayed.

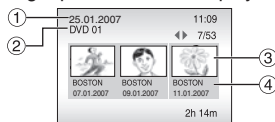

- ① Disc title: Creating date of the disc
- ② DVD number (pg. 42)
- ③ Title thumbnail: First scene of the title
- ④ Title name: Recording date/Playlist name

# Copying Files (Continued)

## Using a VCR/DVD Recorder to Dub Files from the Camera

### Preparation:

Turn off all units.

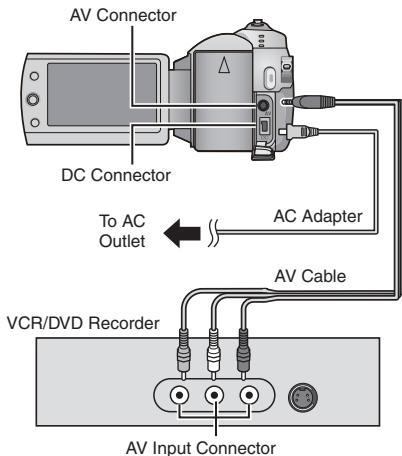

**1** Set the VCR/DVD recorder to its **AUX** input mode.

**2** Start playback on the camera.

- To play back videos (☞ pg. 24)
- To play back playlists ("When dubbing playlists using a VCR/DVD recorder" ☞ pg. 35)

**3** At the point you want to start dubbing, start recording on the VCR/DVD recorder.

Refer to the VCR/DVD recorder's instruction manual.

### ■ To stop dubbing

Stop recording on the VCR/DVD recorder, then press the **REC** button again.

### NOTE

To make the file to record only the date information among the display indications, set [DISPLAY] to [OFF], [DISPLAY ON TV] to [ON], and [DATE/TIME] to [ON] or [AUTO]. (☞ pg. 49)

## Copying/Moving Still Image Files

You can copy or move still image files between the HDD and SD card using the on-screen display.

### Preparation:

- Slide the power/mode switch to **MODE** to select  mode.
- Press the **PLAY/REC** button to select playback mode.
- Make sure that SD card is inserted in the SD slot.
- Make sure that enough free space is left in the copy/move destination medium.

1

FUNCTION

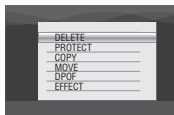

### 2 Select [COPY] or [MOVE].

- **[COPY]:**  
Files are copied to the destination medium while leaving original files in the source medium.
- **[MOVE]:**  
Files are moved to the destination medium while deleting original files (except read-only files) in the source medium.

Select



Set

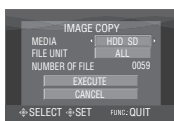

### 3 Set the direction of copy/move. (HDD → SD or SD → HDD)



4



### 5 Set the file unit ([ALL] or [FILE]) to copy/move.



#### • [FILE]:

Select when you want to transfer the selected files.

- 1) Move the set lever to  $\wedge / \vee / \langle / \rangle$  to select the desired file, then press down.

- The  $\checkmark$  mark appears on the file. To select other files, repeat this step.

- 2) Press **FUNCTION**.

#### • [ALL]:

Select when you want to transfer all files in the recording medium.

### 6 Select [EXECUTE].

Select



Set

File transfer starts. When [COPYING/ MOVING COMPLETED] appears, press down the set lever.

#### ■ To exit the screen

Press **MENU**, then move the set lever to  $\wedge / \vee$  to select [EXECUTE] and press down.

#### ■ To stop the file transfer

- 1) Press down the set lever.
- 2) Select [EXECUTE] and press down the set lever.

# Changing the Menu Settings

ex.) Set [DEMO MODE] to [OFF].



3 Select the desired menu from the first menu item.

- **[VIDEO]:**  
Display menus related to mode.
- **[IMAGE]:**  
Display menus related to mode.
- **[GENERAL]:**  
Display menus common to and modes.
- **[MEDIA]:**  
Display menus related to recording media (HDD and SD cards).



4 Select the desired menu from the second menu item.

For details on each menu, see below.





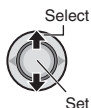



5 Select the desired setting from the third menu item.





















- **To return to the previous screen**  
Move the set lever to  $\leftarrow$ .
- **To exit the screen**  
Press **MENU**.

Menus		Settings: [ ] = Factory-preset
VIDEO	<b>← QUALITY</b> Enables you to set the picture quality for videos.	<b>ULTRA FINE / [FINE] / NORMAL / ECONOMY</b>
	<b>▲ ZOOM</b> Enables you to set the maximum zoom ratio.	<b>34X / [68X] / 800X</b> <b>NOTE</b> When the smallest value is set, the optical zoom is used. When one of the larger values is set, the digital zoom is used.







Menus		Settings: [ ] = Factory-preset
VIDEO	 <b>DIS</b> Compensates for hand shake.	<b>OFF:</b> Disables the function. <b>[ON]:</b> Activates the function. <b>NOTES</b> <ul style="list-style-type: none"> <li>● Accurate stabilisation may not be possible if hand shake is excessive, or depending on the shooting conditions.</li> <li>● Switch off this mode when recording with the camera on a tripod.</li> </ul>
	 <b>16:9 WIDE RECORDING</b> Records videos in 16:9 size.	<b>OFF:</b> Records videos in 4:3 size. <b>[ON]:</b> Records videos in 16:9 size. The <b>16:9</b> indicator lights up on the LCD monitor. <b>NOTES</b> <ul style="list-style-type: none"> <li>● If the recording mode is set to ECONOMY, you cannot record in 16:9 size (the <b>16:9</b> indicator lights up blue).</li> <li>● If you want to burn the recorded videos onto DVD discs, it is recommended not to mix 16:9 size videos and 4:3 size videos.</li> <li>● If you record videos in 16:9 size, the aspect ratio of the video may be incorrect when watching the videos on your TV. If this occurs, change the settings in [SELECT TV TYPE]. (pg. 49)</li> </ul>
	 <b>GAIN UP</b> Makes the subject appear bright automatically when you record in dark places. However, the overall colour tones appear grayish.	<b>OFF:</b> Disables the function. <b>[ON]:</b> Activates the function.
	 <b>WIND CUT</b> Reduces noise caused by wind.	<b>[OFF]:</b> Disables the function. <b>ON:</b> Activates the function.
	 <b>REC MEDIA FOR VIDEO</b> Enables you to set the recording medium for videos.	[HDD] / SD
IMAGE	 <b>SCENE COUNTER</b> Enables you to set whether to display the scene counter.	<b>[OFF]:</b> Disables the function. <b>ON:</b> Activates the function.
	 <b>QUALITY</b> Enables you to set the picture quality for still images.	[FINE] / STANDARD

# Changing the Menu Settings (Continued)

Menus		Settings: [ ] = Factory-preset
IMAGE	<b>AGC GAIN UP</b> Makes the subject appear bright automatically when you record in dark places. However, the overall colour tones appear grayish.	<b>OFF</b> : Disables the function. <b>[ON]</b> : Activates the function.
	 <b>CONTINUOUS SHOOTING</b> Records still images continuously while the <b>SNAPSHOT</b> button is pressed.	<b>[OFF]</b> : Disables the function. <b>ON</b> : Activates the function. <b>NOTES</b> <ul style="list-style-type: none"> <li>• The interval between recording still images is approx. 0.3 seconds.</li> <li>• Continuous shooting may not work well depending on the recording medium.</li> <li>• The continuous shooting speed will drop if this function is used repeatedly.</li> </ul>
	 <b>SELF-TIMER</b> Starts recording when the set time elapses after the <b>SNAPSHOT</b> button is pressed.	<b>[OFF] / 2SEC / 10SEC</b>
	 <b>REC MEDIA FOR IMAGE</b> Enables you to set the recording medium for still images.	<b>[HDD] / SD</b>
GENERAL	 <b>BRIGHT</b> Enables you to set the brightness of the LCD monitor.	Adjust the brightness of the display moving the set lever to </>, then press down.
	 <b>DROP DETECTION</b> Prevents damage to the HDD by turning off the power automatically when the camera detects that it has been dropped.	<b>OFF</b> : Disables the function. <b>[ON]</b> : Activates the function. To turn the unit on when the drop detection worked, set the power/mode switch to <b>OFF</b> , and to <b>ON</b> again. <b>CAUTION</b> Setting this function to off increases the chances of damaging the built-in hard disk if the camera is accidentally dropped.
	 <b>DEMO MODE</b> Introduces special features of the camera at the following cases. <ul style="list-style-type: none"> <li>• When the menu screen is closed.</li> <li>• When there is no operation for about 3 minutes during recording mode.</li> </ul>	<b>OFF</b> : Disables the function. <b>[ON]</b> : Activates the function. <b>NOTES</b> <ul style="list-style-type: none"> <li>• The demonstration only works when the DC cord is connected, not with the battery.</li> <li>• If an SD card is in the camera, demonstration will not take place even if this mode is set to [ON].</li> </ul>
	 <b>OPERATION SOUND</b> Enables you to set the operation sound or turn the operation sound on/off.	<b>OFF</b> : Turns off the operation sound. <b>[MELODY]</b> : The melody sounds when any operation is performed.

Menus	Settings: [ ] = Factory-preset
 <b>SELECT TV TYPE</b> Enables you to select the TV type when watching files recorded on the camera on your TV.	4:3 / [16:9]
 <b>DISPLAY</b> Enables you to set whether to display the on-screen display.	<b>[OFF]:</b> Turns off the on-screen display. <b>[ON]:</b> Turns on the on-screen display.
 <b>DISPLAY ON TV</b> Used for displaying camera's on-screen display on a TV screen.	<b>[OFF]:</b> Does not display on TV. <b>ON:</b> Displays on TV.
 <b>LANGUAGE</b> Enables you to set the display language. (⇨ pg. 13)	<b>[ENGLISH] / FRANÇAIS / DEUTSCH / ESPAÑOL / ITALIANO / NEDERLANDS / PORTUGUÊS / РУССКИЙ / POLSKI / ČEŠTINA / TÜRKÇE</b>
 <b>CLOCK ADJUST</b> Enables you to set the time. (⇨ pg. 13)	DATE / TIME
 <b>DATE DISPLAY STYLE</b> Enables you to set the date and time display format.	<b>DATE STYLE:</b> <b>year.month.day / month.day.year / [day.month.year]</b> <b>TIME:</b> <b>[24h] / 12h</b>
 <b>DATE/TIME</b> Enables you to set whether to display the current time on the LCD monitor.	<b>[OFF]:</b> The date/time does not appear. <b>[AUTO]:</b> The date/time appears for approx. 5 seconds in the following cases. <ul style="list-style-type: none"> <li>● When the power/mode switch is set from <b>OFF</b> to <b>ON</b></li> <li>● When playback starts</li> <li>● When the date is changed during playback</li> </ul> <b>ON:</b> The date/time is always displayed.
 <b>PRESET</b> Returns all the camera settings to their default values.	<b>EXECUTE:</b> Performs this function. <b>[CANCEL]:</b> Returns to the menu screen without executing reset.
 <b>QUICK RESTART</b> Enables the camera to start up quickly when you turn the power off and then on again within five minutes by closing and opening the LCD monitor. ("Power-linked operation" ⇨ pg. 8)	<b>[OFF]:</b> Disables the function. <b>[ON]:</b> Activates the function. The  or  lamp flashes when closing the LCD monitor. <p><b>NOTE</b>            This function is not available during charging.</p>
 <b>AUTO POWER OFF</b> If the camera is not operated for 5 minutes while the power is on, it turns itself off automatically to conserve power.	<b>[OFF]:</b> Disables the function. <b>[ON]:</b> Activates the function. To turn the camera on again, set the power/mode switch to <b>OFF</b> , then to <b>ON</b> when using the battery pack. When using the AC adapter, perform any operation such as zooming.

# Changing the Menu Settings (Continued)

Menus	Settings: [ ] = Factory-preset
<p> <b>CLEAN-UP HDD</b> Writing speed to HDD tends to become slow after long periods of repeated use. Execute cleanup periodically to regain the writing speed.</p>	<p>Connect the AC adapter. <b>EXECUTE:</b> Performs this function. Select [OK] when completed. <b>[CANCEL]:</b> Cancels this function. <b>NOTE</b> Depending on the condition of the HDD, it may take several minutes for the cleanup process to be completed.</p>
<p> <b>FORMAT HDD</b> This will ensure stable speeds and operation when accessing the hard disk drive.</p>	<p><b>EXECUTE:</b> Performs this function. Select [OK] when completed. <b>[CANCEL]:</b> Cancels this function. <b>NOTES</b></p> <ul style="list-style-type: none"> <li>● Be aware that all files and data including protected files will be erased by the formatting process.</li> <li>● Do not format the recording medium on your PC.</li> </ul>
<p> <b>DELETE DATA ON HDD</b> This will make it more difficult to recover data on the HDD which has already been erased. It is recommended that you do this when disposing of the camera to prevent illegal data recovery (using commercially available software).</p>	<p>Connect the AC adapter. <b>EXECUTE:</b> Performs this function. Select [OK] when completed. <b>[CANCEL]:</b> Cancels this function.</p>
<p> <b>FORMAT SD CARD</b> You have to format newly purchased SD cards with this camera before using them. This will also ensure stable speeds and operation when accessing the SD card.</p>	<p><b>EXECUTE:</b> Performs this function. Select [OK] when completed. <b>[CANCEL]:</b> Cancels this function. <b>NOTES</b></p> <ul style="list-style-type: none"> <li>● Be aware that all files and data including protected files will be erased by the formatting process.</li> <li>● Do not format the recording medium on your PC.</li> </ul>
<p> <b>VIDEO NO. RESET</b>  <b>IMAGE NO. RESET</b> By resetting the file number (name), a new folder will be made. The new files you are going to make will be stored in the new folder. It is convenient to separate the new files from previously recorded files.</p>	<p><b>EXECUTE:</b> Performs this function. Select [OK] when completed. <b>[CANCEL]:</b> Cancels this function.</p>

# Troubleshooting

The camera is a microcomputer-controlled device. External noise and interference (from a TV, a radio, etc.) might prevent it from functioning properly.

**The following phenomena are not malfunctions.**

- The camera heats up when it is used for a long time.
- The battery heats up during charging.
- When playing back a video file, the image stops momentarily or the sound is interrupted at junctions between scenes.

- To solve the problem, first follow the instructions below.
- If the problem is not solved, reset the camera. (☞ below)
- If the problem persists, please consult your nearest JVC dealer.

■ **To reset the camera**

- 1) Set the power/mode switch to **OFF** and remove the power supply (battery pack or AC adapter) from the camera, then reattach it.
- 2) Execute [PRESET] from the menu. (☞ pg. 49)



Trouble		Action	☞
<b>Power</b>	<b>No power is supplied.</b>	<ul style="list-style-type: none"> <li>● Connect the AC adapter securely.</li> <li>● Detach the battery pack once again and re-attach it firmly.</li> <li>● Replace the dead battery with a fully charged one.</li> </ul>	12 12 –
	<b>No display appears.</b>	<ul style="list-style-type: none"> <li>● If the camera is not operated for 5 minutes while the power is on, it turns itself off automatically to conserve power. To turn the camera on again when using the battery pack, set the power/mode switch to <b>OFF</b>, then to <b>ON</b>. When using the AC adapter, perform any operation such as zooming.</li> <li>● Adjust the brightness of the LCD monitor.</li> </ul>	– 48
	<b>The power was turned off accidentally.</b>	<ul style="list-style-type: none"> <li>● Move to a place where no vibration or excessive sound.</li> <li>● The drop detection function operated. Set the power/mode switch to <b>OFF</b>, and to <b>ON</b> again. To turn off this function, set [DROP DETECTION] to [OFF].</li> </ul>	– 48
	<b>The displayed amount of remaining battery power differs from the actual operating time.</b>	<ul style="list-style-type: none"> <li>● Fully charge the battery, and then run it down. If the problem persists, the battery is worn out and needs to be replaced. Please purchase a new one.</li> </ul>	12
	<b>The power does not turn on, or the battery operation time is extremely short even after the battery is fully charged.</b>	<ul style="list-style-type: none"> <li>● Make sure to use the camera under appropriate operating temperatures.</li> <li>● The battery is worn out and needs to be replaced. Please purchase a new one.</li> </ul>	56 –
	<b>The access/charge lamp on the camera does not light during charging.</b>	<ul style="list-style-type: none"> <li>● Charging is difficult in places subject to extremely high/low temperatures. To protect the battery, it is recommended to charge it in places with a temperature of 10°C to 35°C.</li> <li>● When the battery is already fully charged, the lamp does not light. Check the remaining battery power.</li> </ul>	–
			14

# Troubleshooting (Continued)

Trouble		Action	
Displays	Images on the LCD monitor appear dark or whitish.	<ul style="list-style-type: none"> <li>Adjust the brightness and angle of the LCD monitor.</li> <li>When the LCD monitor's LED light reaches the end of its service life, images on the LCD monitor become dark. Consult your nearest JVC dealer.</li> </ul>	48 –
	Coloured bright spots appear on the LCD monitor.	<ul style="list-style-type: none"> <li>The LCD monitor is made with high precision technology. However, black spots or bright spots of light (red, green or blue) may appear constantly on the LCD monitor. These spots are not recorded on the picture. This is not due to any defect of the unit. (Effective dots: more than 99.99 %)</li> </ul>	–
	Aspect ratio of the image is strange when watching images on your TV. 	<ul style="list-style-type: none"> <li>Change the settings in [SELECT TV TYPE] so that it matches the screen size of the connected TV.</li> </ul>	49
Recording	Recording cannot be performed.	<ul style="list-style-type: none"> <li>Recording medium is full. Delete unnecessary files or replace the SD card.</li> <li>Select the recording medium properly.</li> </ul>	30 47, 48
	Vertical lines appear on recorded images.	<ul style="list-style-type: none"> <li>Such a phenomenon occurs when shooting a subject illuminated by bright light. This is not a malfunction.</li> </ul>	–
	The LCD monitor becomes red or black for an instant.	<ul style="list-style-type: none"> <li>Such a phenomenon occurs when shooting under direct sunlight. This is not a malfunction.</li> </ul>	–
	During recording, the date/time does not appear.	<ul style="list-style-type: none"> <li>Set [DATE/TIME] to [ON].</li> </ul>	49
	During video recording, the ●REC indicator flashes.	<ul style="list-style-type: none"> <li>The temperature of the camera is increasing. If the camera continues to heat up, recording may be stopped to protect the recording medium. In this case, turn off the power, and then wait until the camera cools down.</li> </ul>	–
	The LCD monitor indications blink.	<ul style="list-style-type: none"> <li>Certain modes of program AE, effect, DIS, and other functions that cannot be used together are selected at the same time.</li> </ul>	–
	Digital zoom does not work.	<ul style="list-style-type: none"> <li>Change the settings in [ZOOM].</li> <li>Digital zoom is not available in the still image recording mode.</li> </ul>	46 –
	The focus is not adjusted automatically.	<ul style="list-style-type: none"> <li>Set focus to the automatic mode.</li> <li>Clean the lens and check the focus again.</li> </ul>	22 55
The colour of the image looks strange.	<ul style="list-style-type: none"> <li>Wait to become natural colour. The camera adjusts the white balance automatically but it takes a time.</li> <li>Try manual white balance adjustment.</li> <li>In bright places, setting "Nightscope" or a slow speed is not recommended.</li> <li>When the recorded image is too dark, try backlight compensation or adjust brightness.</li> <li>When the recorded image is too bright, try adjust brightness.</li> </ul>	–	
		23	
		–	
		21, 22	
		22	

	Trouble	Action	
Recording	White balance setting cannot be activated.	<ul style="list-style-type: none"> <li>Do not select the sepia (SEPIA) or monotone (MONOTONE) mode before setting white balance.</li> </ul>	23
	The continuous shooting speed is slow.	<ul style="list-style-type: none"> <li>The continuous shooting speed will drop when repeatedly making continuous shots, when using certain recording media, or under certain recording conditions.</li> </ul>	—
Playback	Playback cannot be performed.	<ul style="list-style-type: none"> <li>Select the recording medium properly.</li> <li>To watch images on a TV, set the TV's input mode or channel that is appropriate for video playback.</li> </ul>	47, 48 29
	The black & white fader does not work.	<ul style="list-style-type: none"> <li>Do not select the sepia (SEPIA) or monotone (MONOTONE) mode before setting white balance.</li> </ul>	28
	There is a noise during playback.	<ul style="list-style-type: none"> <li>The sound of the hard disk drive may have been recorded if the camera was moved suddenly during recording. Do not move or shake the camera suddenly during recording.</li> </ul>	—
	During video playback, the ► indicator flashes.	<ul style="list-style-type: none"> <li>The temperature of the camera is increasing. If the camera continues to heat up, playback may be stopped to protect the recording medium. In this case, turn off the power, and then wait until the camera cools down.</li> </ul>	—
Other problems	Files cannot be deleted.	<ul style="list-style-type: none"> <li>Remove protection from the files and delete them.</li> </ul>	31
	When the image is printed from the printer, a black bar appears at the bottom of the screen.	<ul style="list-style-type: none"> <li>This is not a malfunction. This can be avoided by recording with DIS activated.</li> </ul>	47
	The data process is too slow after the power is switched on or the mode is changed.	<ul style="list-style-type: none"> <li>There is a large number of still images (approx. 1,000 or more) stored in the recording medium. Copy the stored files to a PC, and delete them from the recording medium.</li> </ul>	30
	The SD card cannot be removed from the camera.	<ul style="list-style-type: none"> <li>Push the SD card in a few more times.</li> </ul>	15
	The CREATE DVD screen is displayed in the LCD monitor, and no other operations can be performed.	<ul style="list-style-type: none"> <li>Another operation is being attempted while a DVD burner that is switched on is connected. Switch off the DVD burner power, and switch the camera's power off and back on again.</li> </ul>	—

# Warning Indications

Indication	Meaning/Action	☑
 (Battery indicator)	<ul style="list-style-type: none"> <li>Displays the remaining battery power.   </li> <li>As the battery power comes close to nil, the battery indicator blinks. When the battery power is exhausted, power turns off automatically.</li> </ul>	<p>–</p> <p>–</p>
SET DATE/TIME!	<ul style="list-style-type: none"> <li>Appears when the date/time is not set.</li> <li>The built-in clock's rechargeable lithium battery is discharged, so the previously set date/time is erased. Connect the camera to an AC outlet using the AC adapter for over 24 hours to charge the clock's lithium battery. Then set the date/time.</li> </ul>	<p>13</p> <p>12</p>
LENS COVER	<ul style="list-style-type: none"> <li>Appears for 5 seconds after power is turned on in recording mode if the lens cover is closed or when it is dark.</li> </ul>	–
HDD ERROR! MEMORY CARD ERROR!	<ul style="list-style-type: none"> <li>Remove the card once and insert it again. If the error is not cancelled, replace the card with one that has been guaranteed for correct operation.</li> <li>Perform clean up to restore the capacity of the recording media.</li> </ul>	<p>15</p> <p>50</p>
CHECK CARD'S WRITE PROTECTION SWITCH	<ul style="list-style-type: none"> <li>Appears when you attempt recording when the write/erase protection tab on the SD card is set to the "LOCK" position.</li> </ul>	30
VIDEO MANAGEMENT FILE IS BROKEN. TO RECORD/PLAYBACK VIDEO, RECOVERY IS REQUIRED. RECOVER?	<ul style="list-style-type: none"> <li>The video management file is broken. Recovery is required to record or play back video files. Move the set lever to ^ / v to select [YES], then press down to recover the video management file.</li> </ul>	–
CAN NOT READ EVENT INFORMATION	<ul style="list-style-type: none"> <li>Appears when the event information cannot be read.</li> </ul>	–
RECORDING FAILURE	<ul style="list-style-type: none"> <li>Performance of recording medium is poor. Use the Cleanup function.</li> <li>The writing speed of recording medium is slow, or the recording medium is corrupted. Use an SD card that is guaranteed to operate.</li> <li>The recording medium was subjected to vibrations or jolts. Be careful not to subject the recording medium to vibrations or jolts.</li> <li>Appears when the recording medium is full and recording is not possible. Delete unnecessary files, or replace the SD card.</li> </ul>	<p>50</p> <p>15</p> <p>–</p> <p>30</p>
INCOMPATIBLE USB DEVICE	<ul style="list-style-type: none"> <li>Appears when an incompatible USB device is connected to the camera.</li> <li>Appears when a DVD burner that is switched off is connected. If you want to use the DVD burner, switch the power on.</li> </ul>	<p>–</p> <p>–</p>

Indication	Meaning/Action	
<b>RECORDING MAY NOT BE CORRECT ON THE MEMORY CARD</b>	<ul style="list-style-type: none"> <li>• The data may not be recorded on the recording medium correctly. Try recording again.</li> <li>• Otherwise, clean up the recording medium.</li> </ul>	<p>–</p> <p>50</p>
<b>DROP DETECTION WORKED AND THE POWER IS TURNED OFF</b>	<ul style="list-style-type: none"> <li>• To turn the unit on again, set the power/mode switch to <b>OFF</b>, and to <b>ON</b> again.</li> </ul>	<p>–</p>

## Cleaning

Before cleaning, turn off the camera and remove the battery pack and AC adapter.

### ■ To clean the exterior

Wipe gently with a soft cloth. If the camera is particularly dirty, dip the cloth into diluted mild soap and wring it out well before wiping. Then wipe again with a dry cloth.

### ■ To clean the LCD monitor

Wipe gently with a soft cloth. Be careful not to damage the monitor.

### ■ To clean the lens

Wipe gently with lens cleaning paper.

### NOTES

- Avoid using strong cleaning agents such as benzine or alcohol.
- Mould may form if the lens is left dirty.
- When using a cleaner or chemically treated cloth, refer to the cautions for each product.

# Specifications

## Camera

### ■ For general

#### Power supply

DC 11 V (Using AC adapter)

DC 7.2 V (Using battery pack)

#### Power consumption

Approx. 3 (3.2)\* W

\*When using the LED light

#### Dimensions (W x H x D)

66 mm x 71 mm x 110 mm

#### Weight

Approx. 320 g

(incl. strap)

Approx. 365 g

(incl. battery and strap)

#### Operating temperature

0°C to 40°C

#### Operating humidity

35% to 80%

#### Storage temperature

-20°C to 50°C

#### Pickup

1/6" (800,000 pixels) CCD

#### Lens

F 2.0 to 4.7, f = 2.3 mm to 78.2 mm, 34:1

power zoom lens

#### Filter diameter

ø30.5 mm

#### LCD monitor

2.7" diagonally measured, LCD panel/TFT

active matrix system

#### Speaker

Monaural

#### LED Light

Within 1.5 m

(recommended shooting distance)

#### Language

English/French/German/Spanish/Italian/Dutch/

Portuguese/Russian/Polish/Czech/Turkish

### ■ For video/Audio

#### Format

SD-VIDEO

#### Recording/Playback format

Video: MPEG-2

Audio: Dolby Digital (2 ch)

#### Signal format

PAL standard

#### Recording mode (video)

ULTRA FINE: 720 x 576 pixels, 8.5 Mbps (VBR)

FINE: 720 x 576 pixels, 5.5 Mbps (VBR)

NORMAL: 720 x 576 pixels, 4.2 Mbps (VBR)

ECONOMY: 352 x 288 pixels, 1.5 Mbps (VBR)

#### Recording mode (audio)

ULTRA FINE: 48 kHz, 384 kbps

NORMAL: 48 kHz, 384 kbps

ECONOMY: 48 kHz, 256 kbps

ECONOMY: 48 kHz, 128 kbps

### ■ For still image

#### Format

JPEG

#### Image size

1 mode (640 x 480)

#### Picture quality

2 modes (FINE/STANDARD)

### ■ For connectors

#### AV output

Video output: 1.0 V (p-p), 75 Ω

Audio output: 300 mV (rms), 1 kΩ

#### USB

Mini USB type A and type B, USB 2.0



compliant

## AC Adapter

### Power requirement

AC 110 V to 240 V~, 50 Hz/60 Hz

#### Output

DC 11 V   , 1 A

**Approximate recording time (minutes) (for video)**

Recording medium Quality	HDD		SD Card					
	30 GB* <sup>1</sup>	40 GB* <sup>2</sup>	128 MB	256 MB	512 MB	1 GB	2 GB	4 GB
ULTRA FINE	430	570	1	3	7	14	29	57
FINE	640	850	2	5	10	22	43	85
NORMAL	850	1130	3	7	14	29	57	113
ECONOMY	2250	3000	9	19	38	77	152	298

\*<sup>1</sup> GZ-MG132\*<sup>2</sup> GZ-MG142**Approximate number of storable images (for still image)**

Recording medium Image size/Quality	HDD	SD Card					
		128 MB	256 MB	512 MB	1 GB	2 GB	4 GB
640 x 480 / FINE	9999	521	1040	2062	4164	7683	9999
640 x 480 / STANDARD	9999	1118	2229	4420	8923	9999	9999

# Cautions

## Battery Packs

The supplied battery pack is a lithium-ion battery. Before using the supplied battery pack or an optional battery pack, be sure to read the following cautions:

- **To avoid hazards**
  - ... **do not** burn.
  - ... **do not** short-circuit the terminals. Keep it away from metallic objects when not in use. When transporting, make sure the provided battery cap is attached to the battery. If the battery cap is misplaced, carry the battery in a plastic bag.
  - ... **do not** modify or disassemble.
  - ... **do not** expose the battery to temperatures exceeding 60°C, as this may cause the battery to overheat, explode or catch fire.
  - ... use only specified chargers.
- **To prevent damage and prolong service life**
  - ... do not subject to unnecessary shock.
  - ... charge within the temperature range of 10°C to 35°C. This is a chemical reaction type battery — cooler temperatures impede chemical reaction, while warmer temperatures can prevent complete charging.
  - ... store in a cool, dry place. Extended exposure to high temperatures will increase natural discharge and shorten service life.
  - ... fully charge and then fully discharge the battery every 6 months when storing the battery pack over a long period time.
  - ... remove from charger or powered unit when not in use, as some machines use current even when switched off.

### Terminals

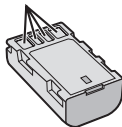

## Recording Medium

- **Be sure to follow the guidelines below to prevent corruption or damage to your recorded data.**
  - Do not bend or drop the recording medium, or subject it to strong pressure, jolts or vibrations.
  - Do not splash the recording medium with water.
  - Do not use, replace, or store the recording medium in locations that are exposed to strong static electricity or electrical noise.
  - Do not turn off the camera power or remove the battery or AC adapter during shooting, playback, or when otherwise accessing the recording medium.
  - Do not bring the recording medium near objects that have a strong magnetic field or that emit strong electromagnetic waves.
  - Do not store the recording medium in locations with high temperature or high humidity.
  - Do not touch the metal parts.
- When formatting or erasing data using the camera, only the file administration information is changed. The data is not completely erased from the hard disk. If you want to completely erase all of the data, we recommend either using commercially available software that is specially designed for that purpose, or by physically destroying the camera with a hammer etc.

## LCD Monitor

- **To prevent damage to the LCD monitor, DO NOT**
  - ... push it strongly or apply any shocks.
  - ... place the camera with LCD monitor on the bottom.
- **To prolong service life**
  - ... avoid rubbing it with coarse cloth.

## Main Unit

### ● For safety, DO NOT

- ... open the camera's chassis.
- ... disassemble or modify the unit.
- ... allow inflammables, water or metallic objects to enter the unit.
- ... remove the battery pack or disconnect the power supply while the power is on.
- ... leave the battery pack attached when the camera is not in use.
- ... place naked flame sources, such as lighted candles, on the apparatus.
- ... expose the apparatus to dripping or splashing.

### ● Avoid using the unit

- ... in places subject to excessive humidity or dust.
- ... in places subject to soot or steam such as near a cooking stove.
- ... in places subject to excessive shock or vibration.
- ... near a television set.
- ... near appliances generating strong magnetic or electric fields (speakers, broadcasting antennas, etc.).
- ... in places subject to extremely high (over 40°C) or extremely low (under 0°C) temperatures.
- ... in places subject to the air pressure is low (more than 3000 m (9870 ft) above the sea level).

### ● DO NOT leave the unit

- ... in places of over 50°C.
- ... in places where humidity is extremely low (below 35%) or extremely high (above 80%).
- ... in direct sunlight.
- ... in a closed car in summer.
- ... near a heater.
- ... in high places such as on a TV. Leaving the unit in high places while a cable is connected may result in a malfunction if the cable is caught and the unit falls onto the floor.

### ● To protect the unit, DO NOT

- ... allow it to become wet.
- ... drop the unit or strike it against hard objects.
- ... subject it to shock or excessive vibration during transportation.
- ... keep the lens directed at extremely bright objects for long periods.
- ... expose the lens to direct sunlight.
- ... swing it excessively when using the hand strap.
- ... swing the soft camera case excessively when the camera is inside it.

## How to Handle a CD-ROM

- Take care not to soil or scratch the mirror surface (opposite to the printed surface). Do not write anything or put a sticker on either the front or back surface. If the CD-ROM gets dirty, gently wipe it with a soft cloth outward from the centre hole.
- Do not use conventional disc cleaners or cleaning spray.
- Do not bend the CD-ROM or touch its mirror surface.
- Do not store your CD-ROM in a dusty, hot or humid environment. Keep it away from direct sunlight.

Dear Customer,

[European Union]

This apparatus is in conformance with the valid European directives and standards regarding electromagnetic compatibility and electrical safety.

European representative of Victor Company of Japan Limited is:  
 JVC Technology Centre Europe GmbH  
 Postfach 10 05 52  
 61145 Friedberg  
 Germany

# Terms

<b>A</b>	AC Adapter .....	12	<b>M</b>	Manual Recording .....	20
	Adjust Brightness .....	22		Menu Settings .....	46
	Auto Power Off .....	49	<b>N</b>	Nightscope .....	21
<b>B</b>	Backlight Compensation .....	21	<b>O</b>	On-Screen Display .....	49
	Battery Pack .....	12, 14, 58		Operation Sound .....	48
	Brightness Control (LCD Monitor) .....	48	<b>P</b>	Partial Delete .....	33
<b>C</b>	Clean-up HDD .....	50		PictBridge .....	38
	Clock Adjust .....	13, 49		Picture Quality .....	46, 47
	Continuous Shooting .....	48		Playlist .....	34
	Copying (Moving) Still Images .....	45		Power-Linked Operation .....	8
	Copying Video Files .....	41, 44		Preset .....	49
	Core Filter .....	7		Printer .....	38
<b>D</b>	Date/Time .....	49		Program AE .....	20
	Date Display Style .....	49		Protecting Files .....	30
	Date Index Screen .....	26	<b>Q</b>	Quick Restart .....	49
	Deleting Files .....	30, 50	<b>R</b>	Recordable Time/Number of Images .....	57
	Deleting Playlist .....	36		Recording Medium .....	19, 47, 48, 58
	Demonstration Mode .....	48		Resetting the Camera .....	51
	Digital Image Stabiliser (DIS) .....	47		Resetting the File Number .....	50
	Direct Printing .....	38	<b>S</b>	Scene Counter .....	47
	Display on TV .....	49		Screen Size (16:9/4:3) .....	47
	DPOF .....	37		SD Card .....	15
	Drop Detection .....	48		Select TV Type .....	49
	DVD Burner .....	40		Self-Timer .....	48
	DVD Recorder .....	44		Shutter Speed .....	23
<b>E</b>	Effect .....	23, 28		Slide Show .....	25
	Event Registration .....	19, 32		Speaker Volume .....	24
	Event Screen .....	26		Spot Exposure Control .....	21
<b>F</b>	File Information .....	32		Still Image .....	17, 25
	Focus .....	22	<b>T</b>	Tele Macro .....	23
	Formatting a Recording Medium .....	50		Tripod Mounting .....	14
<b>G</b>	Gain Up .....	47, 48		TV .....	29
<b>H</b>	Hard Disk .....	58	<b>V</b>	VCR .....	44
<b>I</b>	Image Rotation .....	25		Video .....	16, 24
	Image Size .....	56	<b>W</b>	White Balance .....	23
<b>L</b>	Language Setting .....	12, 49		Wind Cut .....	47
	LCD Monitor .....	8, 10, 58		Wipe or Fader Effects .....	28
	LED Light .....	18	<b>Z</b>	Zooming .....	18, 46
	Lens Cover .....	14			

# JVC