

# JVC



DVD RECEIVER WITH MONITOR

KW-AVX800

ENGLISH

ALAT PENERIMA DVD  
DENGAN MONITOR

KW-AVX800

INDONESIA

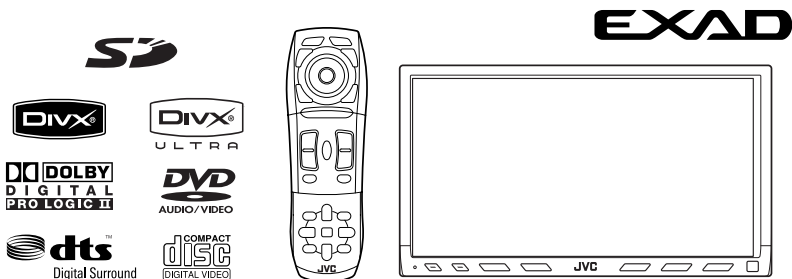

For canceling the display demonstration, see page 8.

Untuk membatalkan tampilan demonstrasi, lihat halaman 8.

For installation and connections, refer to the separate manual.

Untuk instalasi dan penyambungan, lihat buku pedoman terpisah.

## INSTRUCTIONS BUKU PETUNJUK

LVT1667-004A  
[UN]

Thank you for purchasing a JVC product.

Please read all instructions carefully before operation, to ensure your complete understanding and to obtain the best possible performance from the unit.

## IMPORTANT FOR LASER PRODUCTS

- CLASS 1 LASER PRODUCT
- CAUTION:** Do not open the top cover. There are no user serviceable parts inside the unit; leave all servicing to qualified service personnel.
- CAUTION:** Visible and/or invisible class 1M laser radiation when open. Do not view directly with optical instruments.
- REPRODUCTION OF LABEL: CAUTION LABEL, PLACED OUTSIDE THE UNIT.

<b>CAUTION</b> VISIBLE AND/OR INVISIBLE CLASS 1M LASER RADIATION WHEN OPEN. DO NOT VIEW DIRECTLY WITH OPTICAL INSTRUMENTS. IEC60825-1:2007 (EN6)	<b>ATTENTION</b> RAYONNEMENT LASER VISIBLE ET/OU INVISIBLE DE CLASSE 1M UNE FOIS OUVERT. NE PAS REGARDER DIRECTEMENT AVEC DES INSTRUMENTS OPTIQUES. (FRN)	<b>AVISO</b> RADIACION LASER DE CLASE 1M VISIBLE Y/O INVISIBLE CUANDO ESTA ABIERTO. NO MIRAR DIRECTAMENTE CON INSTRUMENTAL OPTICO. (ESP)	<b>VARNING</b> SYNLIG OCH/ELLER OBYNLIG LASERSTRÅLNING, KLASS 1M, NÅR DENNA DEL ÄR ÖPPNAD. BETRAKTA EJ STRÅLEN MED OPTISKA INSTRUMENT. (SWE)	<b>注意</b> ここを覗くと可能 及び/または不可視 のクラス1M レーザー放射が 出ます。 光学装置で直接 見ないでください。 (JPN)	<b>CAUTION</b> VISIBLE AND/OR INVISIBLE CLASS II LASER RADIATION WHEN OPEN. DO NOT STARE INTO BEAM. FDA 21 CFR (EN6) LM44603-003A
--	--	---	---	--	---

### Cautions on the monitor:

- The monitor built in this unit has been produced with high precision, but it may have some ineffective dots. This is inevitable and is not malfunction.
- Do not expose the monitor to direct sunlight.
- Do not operate the touch panel using a ball-point pen or similar tool with the sharp tip. Touch the buttons on the touch panel with your finger directly (if you wear a glove, take it off).
- When the temperature is very cold or very hot..
  - Chemical changes occur inside, causing malfunction.
  - Pictures may not appear clearly or may move slowly. Pictures may not be synchronized with the sound or picture quality may decline in such environments.

### WARNINGS:

#### To prevent accidents and damage

- DO NOT install any unit and wire any cable in locations where;
  - it may obstruct the steering wheel and gearshift lever operations.
  - it may obstruct the operation of safety devices such as air bags.
  - it may obstruct visibility.
- DO NOT operate the unit while driving. If you need to operate the unit while driving, be sure to look around carefully.
- The driver must not watch the monitor while driving.
- The driver must not put on the headphones while driving.



[European Union only]

## How to reset your unit

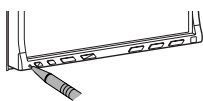

- Your preset adjustments will also be erased.

## How to forcibly eject a disc

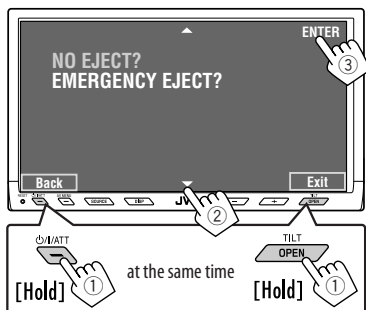

- If this does not work, reset the unit.

### For safety...

- Do not raise the volume level too much, as this will block outside sounds, making driving dangerous.
- Stop the car before performing any complicated operations.

### Temperature inside the car...

If you have parked the car for a long time in hot or cold weather, wait until the temperature in the car becomes normal before operating the unit.

## Contents

<b>INTRODUCTION</b>	
Playable disc type .....	4
Basic operations—	
Monitor panel/touch panel .....	5
Basic operations—	
Remote controller (RM-RK251) .....	6
<b>OPERATIONS</b>	
Before operating the unit .....	8
Common operations .....	9
Listening to the radio .....	10
Disc operations .....	13
Dual Zone operations .....	27
SD operations .....	30
USB operations .....	32
<b>EXTERNAL DEVICES</b>	
Bluetooth® operations—	
Cellular phone/audio player .....	34
Listening to the CD changer .....	41
Listening to the iPod/D. Player .....	43
Using other external components .....	45
<b>SETTINGS</b>	
Sound equalization .....	48
Assigning titles to the sources .....	49
Menu operations .....	50
<b>REFERENCES</b>	
Maintenance .....	60
More about this unit .....	61
Troubleshooting .....	67
Specifications .....	72

# Playable disc type

Disc type	Recording format, file type, etc.	Playable
<b>DVD</b>	DVD Video (Region Code: 3)* <sup>1</sup> 	✓OK
	DVD Audio	
	DVD-ROM	✗NO
<b>DVD Recordable/Rewritable (DVD-R*<sup>2</sup>/-RW, +R/+RW*<sup>3</sup>)</b> <ul style="list-style-type: none"> <li>DVD Video: UDF bridge</li> <li>DVD-VR</li> <li>DivX/MPEG1/MPEG2/JPEG/MP3/WMA/WAV/AAC: ISO 9660 level 1, level 2, Romeo, Joliet</li> <li>DVD-RAM cannot be played.</li> </ul>	DVD Video	✓OK
	DVD-VR (non-CPRM only)	
	DivX/MPEG1/MPEG2	
	JPEG	
	MP3/WMA/WAV/AAC* <sup>4</sup>	✗NO
	MPEG4	
DVD+VR		
<b>Dual Disc</b>	DVD side	✓OK
	Non-DVD side	✗NO
<b>CD/VCD</b>	Audio CD/CD Text (CD-DA)/DTS-CD	✓OK
	VCD (Video CD)	
	CD-ROM	✗NO
	CD-I (CD-I Ready)	
<b>CD Recordable/Rewritable (CD-R/-RW)</b> <ul style="list-style-type: none"> <li>ISO 9660 level 1, level 2, Romeo, Joliet</li> </ul>	CD-DA	✓OK
	MP3/WMA/WAV/AAC* <sup>4</sup>	
	JPEG	
	DivX/MPEG1/MPEG2	✗NO
	MPEG4	

\*1 If you insert a DVD Video disc of an incorrect Region Code, "Region code error" appears on the monitor.

\*2 DVD-R recorded in multi-border format is also playable (except for dual layer discs).

\*3 It is possible to play back finalized +R/+RW (Video format only) discs. However, the use of +R double layer disc is not recommended.

\*4 This unit can play back AAC files encoded using iTunes.

### Caution for DualDisc playback

The Non-DVD side of a "DualDisc" does not comply with the "Compact Disc Digital Audio" standard. Therefore, the use of Non-DVD side of a DualDisc on this product may not be recommended.

## Display <AV Menu>.

- page 50.

## Display <Source Menu>.

- pages 9 and 27.

### Display and erase the Short Cut windows.

Available functions vary among the sources. For details, see each source operation section.

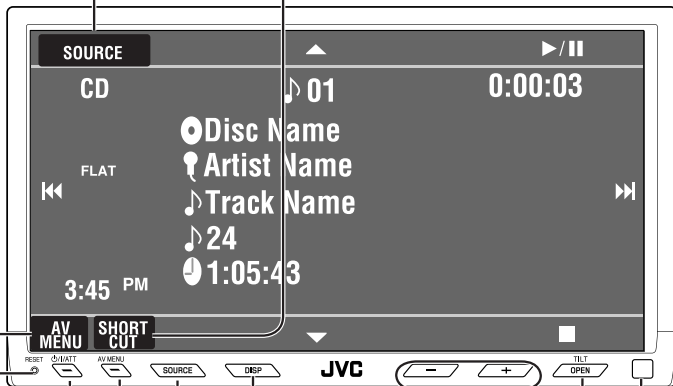

Adjust the volume.

Remote sensor

Change the display information.

Change the sources.

- page 9.

Display <AV Menu>.

- page 50.

- Turn on the power.
- Turn off the power [Hold].
- Attenuate the sound (if the power is on).

### Reset the unit.

- Use only when the internal system malfunctions.

• For details on the touch panel operations, see each source operation sections.

- Display the <Open/Tilt> screen
- Eject the disc and display the <Open/Tilt> screen [Hold].
- Close the monitor panel when the <Open/Tilt> screen is displayed.



- [OPEN]: Open the monitor panel.
- [EJECT]: Eject the disc.
- [CLOSE]: Close the monitor panel.
- [TILT +/-]: Tilt the monitor panel.
- [Exit]: Erase this screen.
- Shaded icons cannot be used at that time.

# Basic operations — Remote controller (RM-RK251)

## Installing the battery

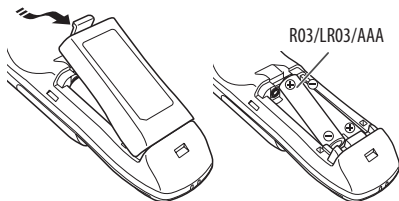

If the range or effectiveness of the remote controller decreases, replace both batteries.

### Before using the remote controller:

- Aim the remote controller directly at the remote sensor on the unit.
- DO NOT expose the remote sensor to bright light (direct sunlight or artificial lighting).

### Caution:

- Do not expose batteries to heat or flame.

### IMPORTANT:

If Dual Zone is activated (page 27), the remote controller functions only for operating the DVD/CD player.

## Main elements and features

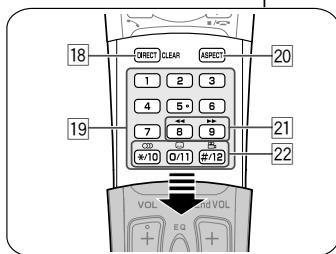
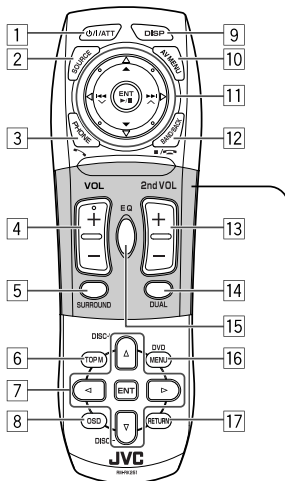

- 1\*1 • Turns on the power.
- Attenuates the sound if the power is on.
- Turns off the power if pressed and held (while the power is on).
- 2\*1 Selects the source.
- 3\*1 • Displays <Dial Menu>.
- Displays <Redial> list if pressed and held.
- Answers incoming calls.
- 4\*1,2 Adjusts the volume level.

- 5\*<sup>1,2</sup> Selects surround mode.
- 6
- DVD/DivX 6: Shows the disc menu.
  - VCD: Resumes PBC playback.
  - DVD-VR: Shows the Original Program screen.
- 7
- Makes selection/settings.
  - ◀▶: Skips back or forward by 5 minutes for DivX/MPEG1/MPEG2.
  - DISC +/- buttons: Changes discs for "CD-CH."
- 8 Shows the on-screen bar.
- 9\*<sup>1</sup> Changes the display information.
- 10 Display or erase <AV Menu>.
- 11 **For disc/SD/USB operations:**
- ▶/II: Plays/pauses.
  - ▲ / ▼:
    - DVD: Selects the title/group.
    - DVD-VR: Selects the program/playlist.
    - SD/USB/other discs (except VCD/CD): Selects the folders.
  - I◀◀/▶▶I:
    - Press briefly: reverse skip/forward skip.
    - Press and hold: reverse search/forward search.
- For FM/AM operations:**
- ▲ / ▼: Selects the preset stations.
  - I◀◀/▶▶I: Functions to search for stations.
    - Press briefly: Auto Search
    - Press and hold: Manual Search
- For Apple iPod/JVC D. player operations:**
- ▼: Pauses/stops or resumes playback.
  - ▲: Enters the main menu (then ▲ / ▼ / I◀◀/▶▶I work as the menu selecting buttons).<sup>\*3</sup>
  - I◀◀/▶▶I (in menu selecting mode)
    - Selects an item if pressed briefly. (Then, press ▼ to confirm the selection.)
    - Skips 10 items at a time if pressed and held.
- For Bluetooth operations:**
- I◀◀/▶▶I: reverse skip/forward skip (for audio operation)
  - ▶/II: Answers incoming calls (for "Bluetooth PHONE"), plays/pauses (for "Bluetooth AUDIO").
- 12 TUNER: Selects the bands.  
DISC/SD/USB: Stops play.  
Bluetooth PHONE: Ends the call.  
Bluetooth AUDIO: Plays/pauses.  
• This button does not function as the BACK button for this model.
- 13\*<sup>2</sup> Adjusts the volume level through the 2nd AUDIO OUT plug.
- 14\*<sup>2</sup> Activates or deactivates Dual Zone.
- 15\*<sup>1,2</sup> Selects the sound mode.
- 16
- DVD Video/DivX 6: Shows the disc menu.
  - VCD: Resumes PBC playback.
  - DVD-VR: Shows the Play List screen.
- 17 RETURN button
- For VCD: Returns to the PBC menu.
- 18 DISC/SD/USB: Switches number entry mode.
- Also functions as CLEAR button to erase the misentry after entering the wrong number.
- 19
- Enter the numbers.
  - FM/AM: Selects the preset station directly.
  - CD changer: Selects the disc directly.
- 20\*<sup>1</sup> Changes the aspect ratio of the playback pictures.
- 21 Reverse search/forward search for disc/SD/USB operations.
- 22
- DVD Video: Selects audio language (○○○), subtitles (□□□), angle (□□□).
  - DVD Audio: Selects audio stream (○○○).
  - DVD-VR: Turn on/off subtitles (□□□), and selects audio channel (○○○)
  - DivX: Selects audio language (○○○), subtitles (□□□).
  - VCD: Selects audio channel (○○○).
- \*<sup>1</sup> If Dual Zone is activated, these buttons cannot be used.
- \*<sup>2</sup> These buttons can be used only when the slide cover is closed.
- \*<sup>3</sup> ▲: Returns to the previous menu.  
▼: Confirms the selection.

## Before operating the unit

Cancel the display demonstration and set the clock (see pages 51 and 52 for details).

- Non-available items will be displayed being shaded on the AV Menu screens.

### Indication language:

In this manual, English indications are used for purpose of explanation. You can select the indication language on the monitor. (see page 52)

### 1 Turn on the power.

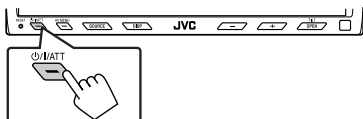

### 2 Display <AV Menu>.



### 3 Display the <Setup> menu.

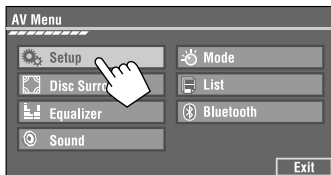

### 4 Cancel the display demonstrations.

Select <Off>.

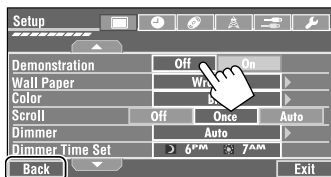

Return to the previous screen.

### 5 Set the clock settings.

Moves to the preceding menu page

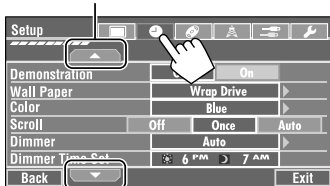

Moves to the succeeding menu page

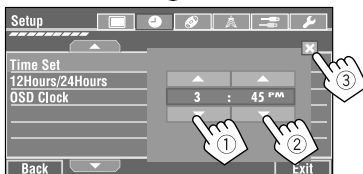

### 6 Finish the procedure.

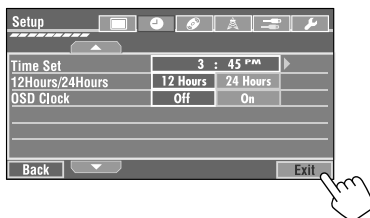

## Common operations

### Selecting the playback source

- Available sources depend on the external components you have connected, media you have attached, and the **<Input>** settings you have made (pages 55 and 56).

#### On the touch panel:

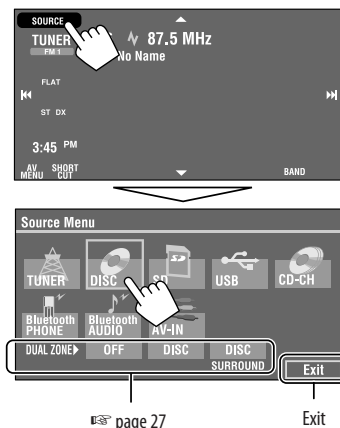

#### On the monitor panel:

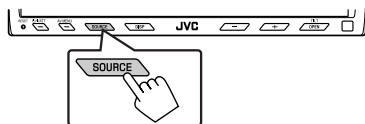

**TUNER** → **DISC** (DVD/VCD/CD) → **SD** → **USB** → **CD-CH**, **iPod**, **D.PLAYER**, or **EXT-IN** → **Bluetooth PHONE** → **Bluetooth AUDIO** → **AV-IN** → (back to the beginning)

- You cannot select these sources if they are not ready.

### Changing the display information

- Available display information varies among the playback sources.

#### On the monitor panel only:

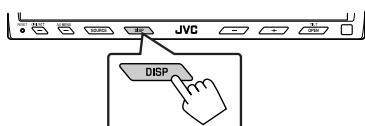

- Each time you press **DISP**, the display changes to show the various information.

Ex. When the playback source is a DivX disc.



Playback picture screen  
(only for video sources)



Source information screen



Preset station (service) list,  
track (file) list, or phone  
number list



Animation screen



Navigation screen  
(When **<Navigation>** is  
selected for **<AV Input>**):  
(page 55).

Back to the beginning

# Listening to the radio

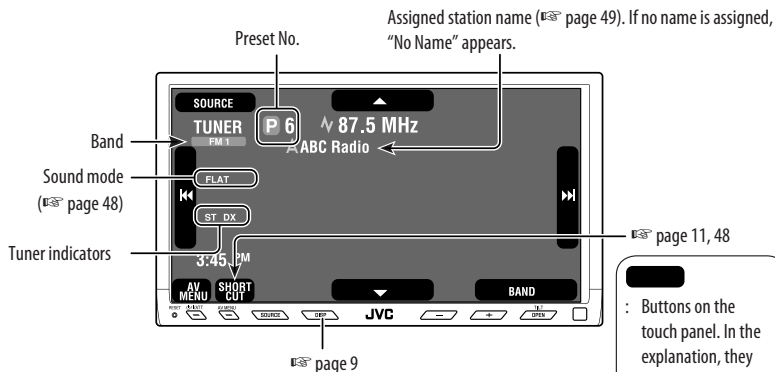

- 1 Press [SOURCE], then press [TUNER].** (page 9)

  - You can also use SOURCE on the monitor panel. Press it repeatedly.
- 2 Press [BAND].** → FM1 → FM2 → FM3 → AM
- 3 Press [◀◀] or [▶▶] to search for a station—Auto Search.**

  - Manual Search: Hold either [◀◀] or [▶▶] until "Manual Search" appears on the display, then press it repeatedly.
  - The ST indicator lights up when receiving an FM stereo broadcast with sufficient signal strength.

## When an FM stereo broadcast is hard to receive

- 1 Press [AV MENU].**



- You can also use AV MENU on the monitor panel.

- 2 Press [Mode].**

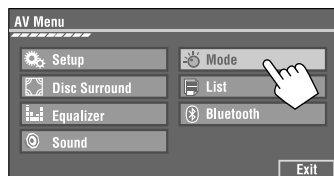

- 3**

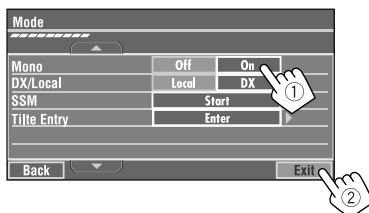

- Reception improves, but stereo effect will be lost.
- The MONO indicator lights up.

To restore stereo effect, select <Off>.

## Tuning in to stations with sufficient signal strength

This function works only for FM bands. Once you have activated this function (selected <Local>), it always works when searching for FM stations.

### 1 Press [AV MENU].



- You can also use AV MENU on the monitor panel.

### 2 Press [Mode].

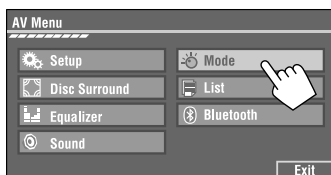

### 3

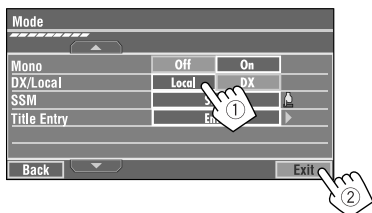

Only stations with sufficient signal strength will be detected.

- The DX indicator goes off, then the LO indicator lights up.

- You can also change <IF Band Width> setting (for details, [page 55](#)).

<IF Band Width> menu can be accessed by pressing [SHORT CUT] on the touch panel, then...

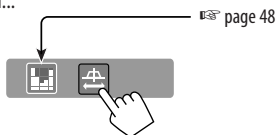

## FM station automatic presetting —SSM (Strong-station Sequential Memory)

This function works only for FM bands. You can preset six stations for each band.

### 1 Press [AV MENU].



- You can also use AV MENU on the monitor panel.

### 2 Press [Mode].

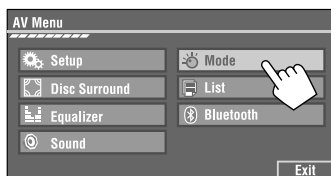

### 3

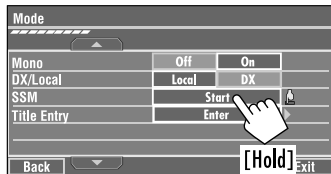

Local FM stations with the strongest signals are searched and stored automatically in the FM band.

## Manual presetting

Ex.: Storing FM station of 92.5 MHz into preset number 4 of the FM1 band.

### 1 Display the Preset List.

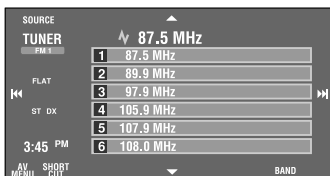
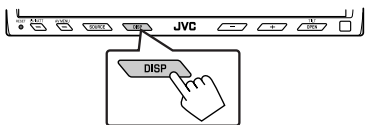

### 2 Tune in to a station you want to preset.

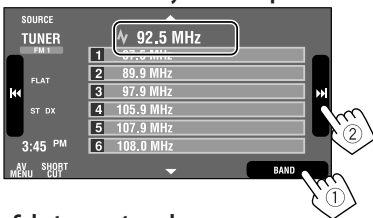

### 3 Select a preset number.

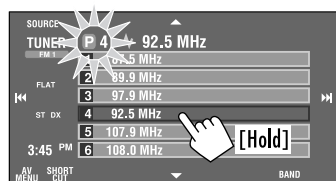

The station selected in step 2 is now stored in preset number 4.

## Selecting preset stations

### On the remote:

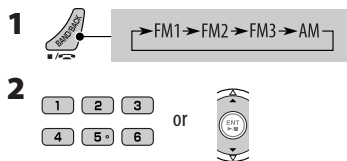

### On the unit:

#### To select directly on the touch panel

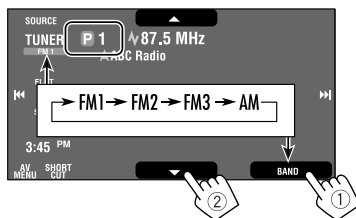

#### To select from the Preset List

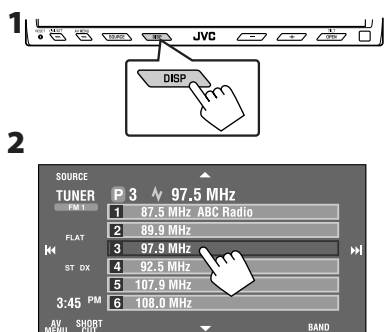

## Disc operations

The disc type is automatically detected, and playback starts automatically (for some discs: automatic start depends on its internal program).

If a disc does not have any disc menu, all tracks in it will be played repeatedly until you change the source or eject the disc.

If "⊘" appears on the monitor, the unit cannot accept the operation you have tried to do.

- In some cases, without showing "⊘," operations will not be accepted.

### 1 Open the monitor panel.

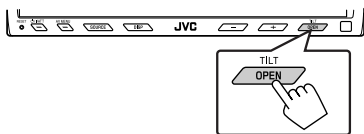

<Open/Tilt> menu appears.

- Shaded icons cannot be used at that time.
- By pressing and holding the button, you can open the monitor panel and eject the disc.

### 2 Press [OPEN].



#### Caution on volume setting:

Discs produce very little noise compared with other sources. Lower the volume before playing a disc to avoid damaging the speakers by the sudden increase of the output level.

### 3 Insert a disc.

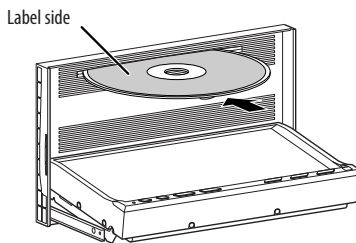

Monitor panel closes automatically.

If not, press [CLOSE].

#### Caution:

Do not place your finger behind the monitor panel.



- [OPEN]: Open the monitor panel.
- [EJECT]: Eject the disc.
- [CLOSE]: Close the monitor panel.
- [TILT +/-]: Tilt the monitor panel.
- [Exit]: Erase this screen.

While playing the following discs, press **DISP**.

- Each time you press the button, the display changes to show the different information (page 9).



DVD Video: Title no./Chapter no./Playing time  
 DVD-VR: Program no./Playlist no./Chapter no./Play time

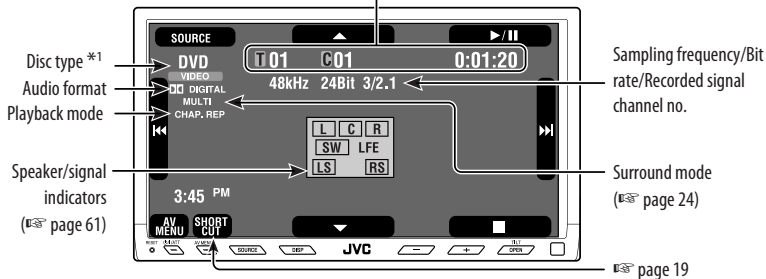

Buttons on the touch panel. In the explanation, they are indicated inside [ ]. These buttons also work when they are not shown on the touch panel (while watching pictures on the screen).

- [▶ / ||] Start and pause playback
- [■] Stop playback
- [◀◀▶▶] Press: Select chapter  
 Hold: Reverse/forward search\*2
- [▲ ▼] Select title/program/playlist



Group no./Track no./Playing time

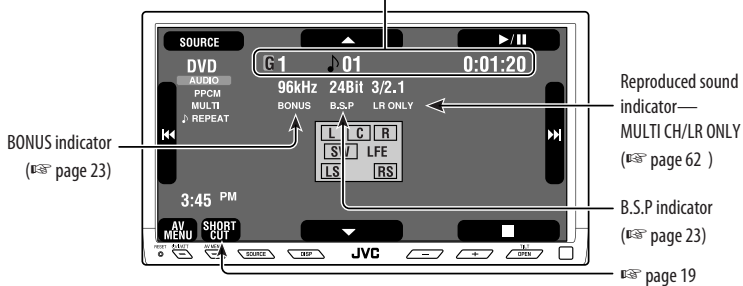

- [▶ / ||] Start and pause playback
- [■] Stop playback
- [◀◀▶▶] Press: Select track  
 Hold: Reverse/forward search\*2
- [▲ ▼] Select group

\*1 DVD-VR also indicates either PRG (program) or PLAY (playlist) playback.

\*2 Search speed: x2 ⇒ x10.

While playing the following discs, press **DISP**.

- Each time you press the button, the display changes to show the different information (page 9).



For DivX/MPEG1/MPEG2: Folder no./Track no./Playing time  
For JPEG: Folder no./Track no.

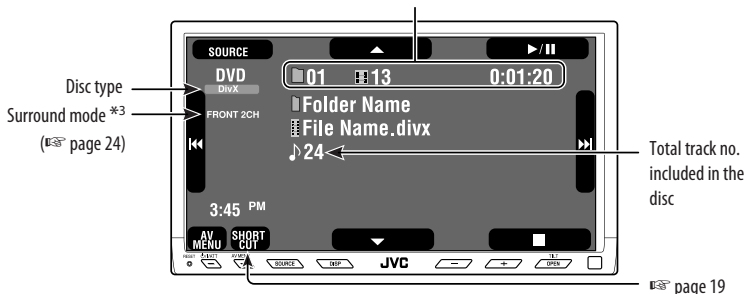

- [▶ / ||] Start and pause playback
- [■] Stop playback
- [|◀◀▶▶|] Press: Select track  
Hold: Reverse/forward search for DivX/MPEG1/MPEG2 \*4
- [▲ ▼] Press: Select folder  
Hold: Display Folder list



Track no./Playing time

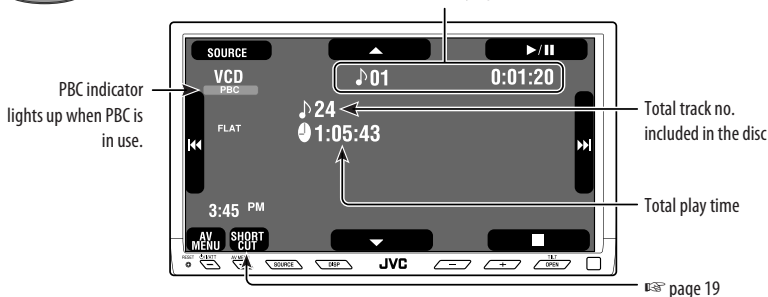

- [▶ / ||] Start and pause playback
- [■] Stop playback
- [|◀◀▶▶|] Press: Select track  
Hold: Reverse/forward search\*2

\*2 Search speed: x2 ⇔ x10.

\*3 Surround mode and sound mode cannot be used at the same time.

\*4 Search speed: ▶▶1 ⇔ ▶▶2.

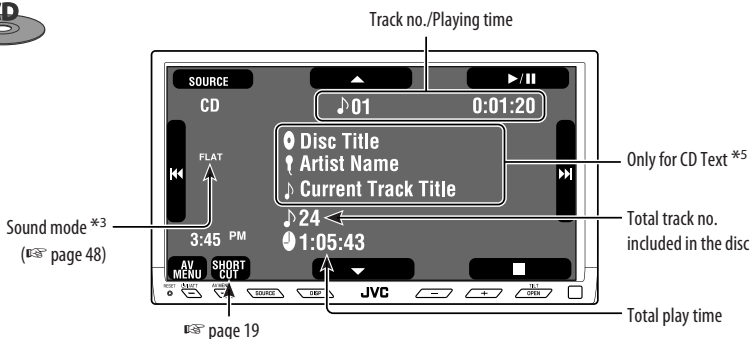

- [▶ / ||] Start and pause playback
- [■] Stop playback
- [◀◀▶▶] Press: Select track  
Hold: Reverse/forward search\*2

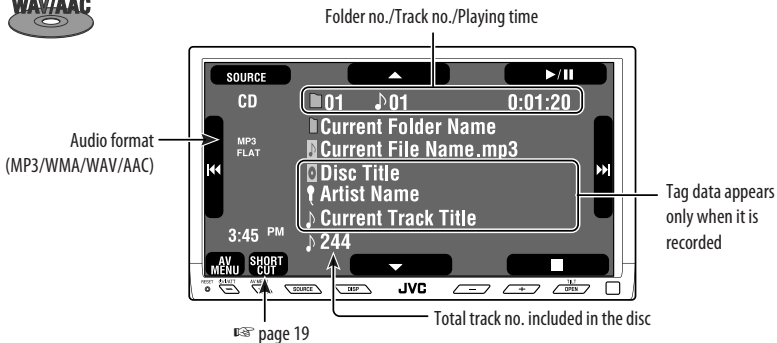
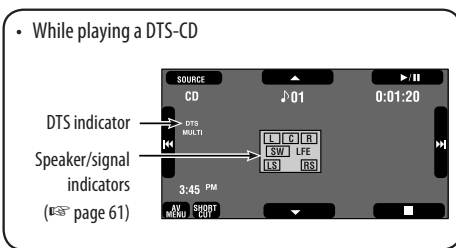

- [▶ / ||] Start and pause playback
- [■] Stop playback
- [◀◀▶▶] Press: Select track  
Hold: Reverse/forward search\*2
- [▲ ▼] Press: Select folder  
Hold: Display Folder list

\*2 Search speed: x2 ⇔ x10.

\*5 "No Name" appears for conventional CDs.

## Operation buttons on the monitor screen

You can display the following operation buttons while watching the playback pictures on the monitor.

- While the operation buttons are displayed, aspect ratio is fixed to <Full> (page 52).
- If no operation is done for about 5 seconds, the operation buttons disappears (except when a disc menu is displayed).

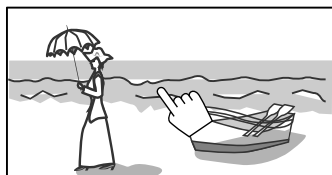

\* Touch the screen (center portion).

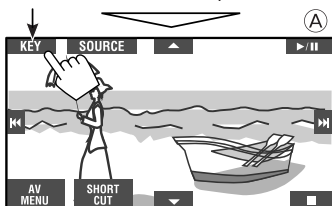

Touch [KEY].

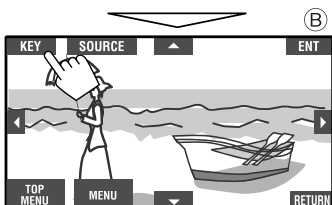

Touch [KEY].

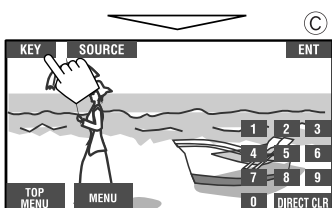

Touch [KEY].

pages 20 to 22 on how the operation buttons particularly work for a variety of the discs

To erase the operations, touch the screen again.

- (A)
- [SOURCE] Display the <Source Menu>
  - [AV MENU] Display the <AV Menu>
  - [SHORT CUT] Display the Short Cut buttons
  - [▶ / ||] Start and pause playback
  - [■] Stop playback
  - [|◀▶▶▶|] Press: Select track  
Hold: Reverse/forward search
  - [▲ ▼] Select folders

• The above buttons also work when they are not shown on the touch panel (while watching pictures on the screen).

\* While a disc menu is played back for DVD, [KEY] is automatically displayed. On the disc menu, you can select a menu item directly by touching it on the screen.

- (B)
- For DVD/VCD/DivX menu operation playback
- [◀▶ ▲ ▼] Select the menu items
  - [ENT] Confirm the selection
  - [TOP MENU] Display the disc menu
  - [MENU] Display the disc menu
  - [RETURN] Return to the previous menu or display the menu (only for VCD with PBC)

- (C)
- For entering the numbers
- [DIRECT CLR] Switch between chapter/track entry and title/group/folder entry  
Erase the last entry when you enter a wrong number
  - [0]–[9]→[ENT] Enter the number
- Ex. To enter "105": press [1], [0], [5], then [ENT]

## Selecting playback modes

You can use only one of the following playback modes—Intro/Repeat/Random.

Ex. To select Track Repeat





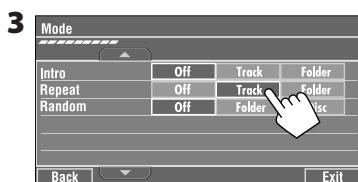
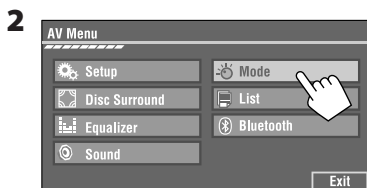





- You can also use AV MENU on the monitor panel.



When one of the playback modes is selected, the corresponding indicator lights up on the source information screen.

To cancel, select <Off>.

Disc type	Intro	Repeat	Random
	—	<b>Chapter:</b> Repeats current chapter <b>Title:</b> Repeats current title	—
	—	<b>Track:</b> Repeats current track	—
	—	<b>Chapter:</b> Repeats current chapter <b>Program:</b> Repeats current program (not available for Playlist playback).	—
 	<b>Track:</b> Plays the first 15 seconds of each track (for VCD: PBC not in use)	<b>Track:</b> Repeats current track*1 (for VCD: PBC not in use)	<b>Disc (All):</b> Randomly plays all tracks (for VCD: PBC not in use)
	<b>Track:</b> Plays the first 15 seconds of each track <b>Folder:</b> Plays the first 15 seconds of the first track of each folder	<b>Track:</b> Repeats current track*1 <b>Folder:</b> Repeats all tracks of the current folder	<b>Folder:</b> Randomly plays all tracks of current folder, then tracks of next folders <b>Disc (All):</b> Randomly plays all tracks
 	—	<b>Track:</b> Repeats current track <b>Folder:</b> Repeats current folder	—
	—	<b>Folder:</b> Repeats current folder	—

\*1 You can also use [SHORT CUT] to turn on and off Track Repeat

## Selecting tracks on the list

If a disc includes folders, you can display the Folder/Track (File) Lists, then start playback.



- You can also use AV MENU on the monitor panel.

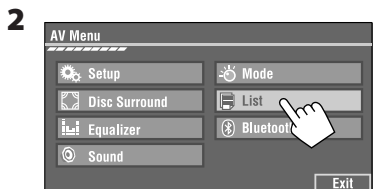

### 3 Select a folder (1), then a track (2).

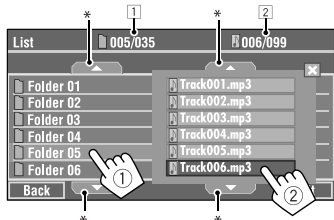

Selected track starts playing. (\* Press to move to the previous/next pages of the list)

- Current folder list number/total folder list number
- Current track list number/total track list number of the current folder

- Track List can also be accessed by pressing DISP on the monitor panel.

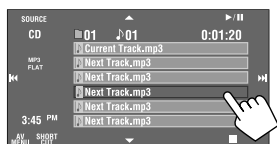
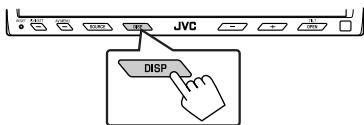

Selected track starts playing.

## Prohibiting disc ejection

You can lock a disc in the loading slot.

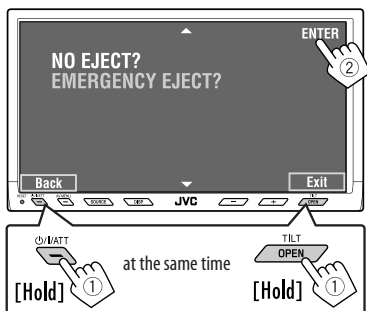

To cancel the prohibition, repeat the same procedure to select <EJECT OK?>.

## Using Short Cut Icons

You can easily access the some frequently used functions by using [SHORT CUT] on the touch panel.



- You can also use AV MENU on the monitor panel.

- 2
- For video software:

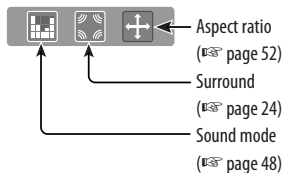

- For audio software:



Turn on or off Track Repeat  
(Repeat play: page 18)

# Operations using the remote controller—RM-RK251

ENGLISH

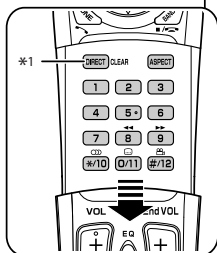
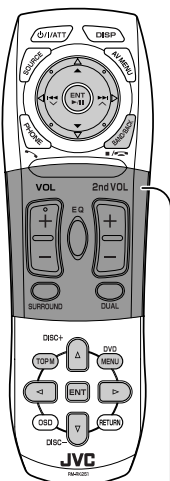

- \*1 Erases the misentry of the number.
- \*2 Search speed:  $x2 \Rightarrow x5 \Rightarrow x10 \Rightarrow x20 \Rightarrow x60$
- \*3 Slow motion speed:  $1/32 \Rightarrow 1/16 \Rightarrow 1/8 \Rightarrow 1/4 \Rightarrow 1/2$
- \*4 Search speed:  $x2 \Rightarrow x10$
- \*5 Search speed:  $\blacktriangleright\blacktriangleright 1 \Rightarrow \blacktriangleright\blacktriangleright 2 \Rightarrow \blacktriangleright\blacktriangleright 3$
- \*6 Search speed:  $\blacktriangleright\blacktriangleright 1 \Rightarrow \blacktriangleright\blacktriangleright 2$



Stop playback.



Start playback/pause (if pressed during playback).



Reverse/forward search\*2. (No sound can be heard.) (Slow motion\*3 during pause. No sound can be heard.)



Press: Select chapter (during playback or pause). Hold: Reverse/forward search\*4.



Select title (during playback or pause).



Select chapter.  
Select title (when not playing).

### Using menu driven features

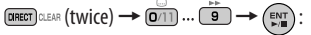

Select title (during playback or pause).

- 1 TOPM MENU
- 2 Select an item you want to start play.



Select aspect ratio.



Select audio language.



Select subtitle language.



Select view angle.

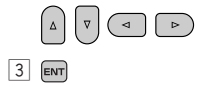

- 3 ENT



Stop playback.



Start playback/pause (if pressed during playback).



Reverse/forward search\*2.



Press: Select track. Hold: Reverse/forward search\*4.



Select group.



Select track.

### Using menu driven features

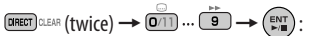

Select group.

- 1 TOPM
- 2 Select an item you want to start play.



Select aspect ratio.



Select audio stream.

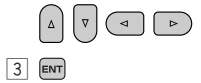

- 3 ENT



- : Stop playback.
- : Start playback/pause (if pressed during playback).
- : Reverse/forward search\*5. (No sound can be heard.)
- : Press: Select track.  
Hold: Reverse/forward search\*6. (No sound can be heard.)

- : Select folder.
- ... → :  
Select track (within the same folder).
- (twice) → ... → :  
Select folder.

- : Select aspect ratio.
- : Select audio language. (DivX only)
- : Select subtitle language. (DivX only)

**While playing...**  
Back/advance the scenes by 5 minutes.

**For DivX6: Using menu driven features**

- 1
- 2 Select an item you want to start play.
- 3

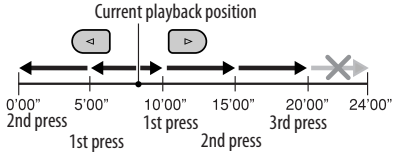

- : Stop playback.
- : Start playback/pause (if pressed during playback).
- : Reverse/forward search\*2. (No sound can be heard.)  
(Slow motion\*3 during pause. No sound can be heard.)  
• Reverse slow motion does not work.

- : Press: Select chapter (during playback or pause).  
Hold: Reverse/forward search\*4.

- : Select program.  
Select playlist (during playback or pause).

- : Select aspect ratio.
- : Select audio channel (ST: stereo, L: left, R: Right).



- : Turn on/off subtitle.
- ... → :  
Select chapter.  
Select program (when not playing).
- (twice) → ... → :  
Select program/playlist (during playback or pause).

**Using Original Program/Play List screens**

- ( page 23)
- 1 : For Original Program  
 : For Play List
  - 2 Select an item you want to start playing.
  - 3 To erase the screen.

**JPEG**

: Stop playback.

: Start playback. (Slide show: each file is shown for a few seconds.)  
Shows the current file until you change it if pressed during Slide show.

: Select track.

: Select folder.

**ASPECT** : Select aspect ratio.

**DIRECT** CLEAR → ... → :  
Select track (within the same folder).

**DIRECT** CLEAR (twice) → ... → :  
Select folder.

**MP3/WMA/WAV/AAC**

: Stop playback.

: Start playback/pause (if pressed during playback).

: Reverse/forward search\*2.

: *Press*: Select track.  
*Hold*: Reverse/forward search\*4.

: Select folder.

**DIRECT** CLEAR → ... → :  
Select track (within the same folder).

**DIRECT** CLEAR (twice) → ... → :  
Select folder.

: Stop playback.

: Start playback/pause (if pressed during playback).

: Reverse/forward search\*2.  
(Forward slow motion\*3 during pause. No sound can be heard.)

- Reverse slow motion does not work.

: *Press*: Select track.  
*Hold*: Reverse/forward search\*4 (No sound can be heard.)

**ASPECT** : Select aspect ratio.

: Select audio channel (ST: stereo, L: left, R: Right).

**VCD**

**DIRECT** CLEAR → ... → :  
Select track.

**During PBC playback...**

**DIRECT** CLEAR → ... → :  
Select an item on the menu.  
To return to the previous menu, press **RETURN**.

**To cancel PBC playback**

- 
- Start the desired track.  
**DIRECT** CLEAR → ... → :  
• To resume PBC, press **TOP/M** / **DVD MENU**.

**CD**

: Stop playback.

: Start playback/pause (if pressed during playback).

: Reverse/forward search\*2.

: *Press*: Select track.  
*Hold*: Reverse/forward search\*4.

**DIRECT** CLEAR → ... → :  
Select track.

\*2 Search speed: x2 ⇔ x5 ⇔ x10 ⇔ x20 ⇔ x60  
\*3 Slow motion speed: 1/32 ⇔ 1/16 ⇔ 1/8 ⇔ 1/4 ⇔ 1/2  
\*4 Search speed: x2 ⇔ x10

## Playing back a bonus group



If a DVD Audio including a “bonus group” is detected, the BONUS indicator lights up on the source information screen.

### To play a bonus group...

#### 1 Select the bonus group.

- The bonus group is usually recorded as the last group.

#### 2 Enter the key number.

: Move the entry position  
 : Select a number



ENT

- “key number” (a kind of password) for the bonus group is not open to public. The way of getting the key number depends on the disc.

#### 3 Follow the interactive instructions shown on the monitor.

## Selecting browsable still picture



When a disc including browsable still pictures is detected, the B.S.P indicator lights up on the source information screen.

When disc shows the BSP selecting icons such as or on the screen...

#### 1 Select an item you want to display.

2 ENT

## Using the list screens



You can use Original Program and Play List screen anytime while playing DVD-VR with its data recorded.

#### 1 Display the Original Program/Play List screen.

TOP

No	Date	Ch	Time	Title
1	25/04/07	4ch	19:00	JVC DVD World 2004
2	17/05/07	8ch	10:30	
3	22/05/07	8ch	17:00	Music Festival
4	26/05/07	L-1	13:19	children 001
5	20/06/07	4ch	22:00	
6	25/06/07	L-1	8:23	children 002

DVD MENU

No	Date	Chap	Length	Title
1	25/05/07	001	1:03:16	My JVC World
2	17/06/07	005	1:35:25	
3	20/06/07	003	0:10:23	Favorite music
4	25/06/07	001	0:07:19	children001-002

#### 2 Select an item you want.



To erase the screen

- Program/Play list number
- Recording date
- Recording source (TV station, the input terminal of the recording equipment, etc.)
- Start time of recording
- Title of the program/play list\*
- Highlight bar (current selection)
- Creating date of play lists
- Total number of chapters included in the playlist
- Playback time

\* The title of the original program or play list may not be displayed depending on the recording equipment.

## Enjoying surround sounds

You can enjoy multi-channel surround playback through the front, center, surround speakers.

- After connecting the center speaker, make sure to activate the center speaker; otherwise, no sound comes out of the center speaker (see page 54).
- Surround mode can also be used for "USB" and "SD."

**MULTI:** For multi-channel encoded sources such as Dolby Digital\*, DTS\*, and DVD Audio. (When activated, "MULTI" is shown on the source information screen.)

**Dolby Pro Logic II (Movie/Music):** For 2 channel sources except for DivX/MPEG1/MPEG2 discs.

### To turn on the surround...

1



- You can also use AV MENU on the monitor panel.

2

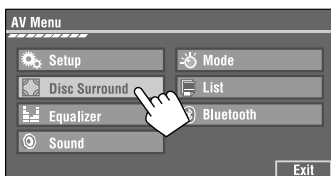

3

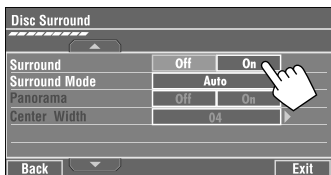

- **Off:** Deactivates surround.
- **On:** Activates surround → go to the following steps.

4

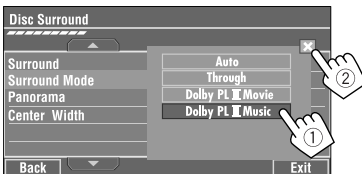
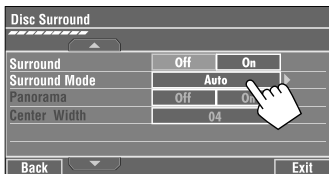

- **Auto:** When multi-channel digital signals come in, "MULTI" surround is activated. When 2-channel or 2.1-channel signals come in, "4CH STEREO" is activated.
- **Through:** All incoming channel signals are sent to the corresponding speakers.
- **Dolby PL II Movie:** Activates Dolby Pro Logic II Movie.
- **Dolby PL II Music:** Activates Dolby Pro Logic II Music. You can adjust <Panorama> and <Center Width> setting (see below).

### Only when selecting <Dolby PL II Music>

After step 4 above...

#### 1 Activate <Panorama>.

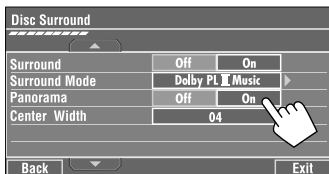

- **Panorama:** Select <On> to add wraparound sound effect.

## 2 Adjust <Center Width>.

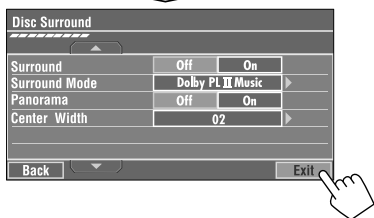
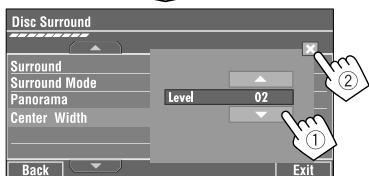
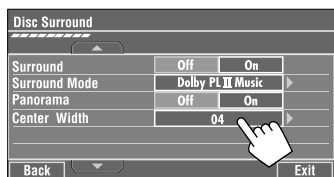

- **Center Width:** Adjust the center image so it may be heard only from the center speaker, only from the left/right front speaker as a “phantom” center image, or various combination of these speakers. As the number increases, the “phantom” effect becomes stronger (normally select <04>).

### On the remote controller:



- You cannot change the <Dolby PL II Music> settings using the remote controller.
- \*1 Manufactured under license from Dolby Laboratories. Dolby, Pro Logic, and the double-D symbol are trademarks of Dolby Laboratories.
- \*2 “DTS” and “DTS Digital Surround” are registered trademarks of DTS, Inc.

## Operations using the on-screen bar

These operations are possible on the monitor using the remote controller, while playing the following discs—DVD/VCD/DivX/MPEG1/MPEG2/JPEG.

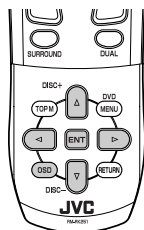

### 1 Display the on-screen bar. (E-38 page 26)

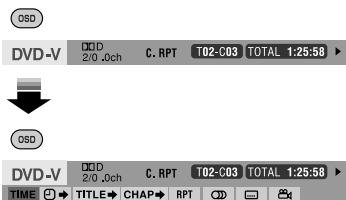

### 2 Select an item.



### 3 Make a selection.

If a pop-up menu appears...



- For entering time/numbers...

< > : Move the entry position

Δ ▽ : Select a number

### To remove the on-screen bar

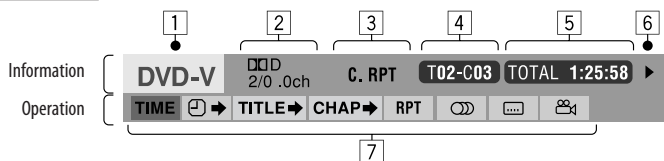

Continued on the next page

**On-screen bar**

Above example is of DVD Video. Items shown on the bar vary due to the disc type.

- |   |   |
|---|---|
| <p><b>1</b> Disc type</p> <p><b>2</b> • DVD: Audio signal format<br/>• VCD: PBC</p> <p><b>3</b> Playback mode *<sup>1</sup><br/>DVD Video:<br/>T. RPT: Title repeat<br/>C. RPT: Chapter repeat<br/>DVD Audio:<br/>T. RPT: Track repeat<br/>DVD-VR:<br/>C. RPT: Chapter repeat<br/>PG. RPT: Program repeat<br/>DivX/MPEG1/MPEG2:<br/>T. RPT: Track repeat<br/>F. RPT: Folder repeat<br/>JPEG:<br/>F. RPT: Folder repeat<br/>VCD:<br/>T. RPT: Track repeat<br/>A. RND: All (Disc) random<br/>T. INT: Track intro</p> <p><b>4</b> Playback information<br/><b>T02-C03</b> Current title/chapter<br/><b>G02-T03</b> Current group/track<br/><b>PG001 C001</b> Current program/chapter<br/><b>PL001 C001</b> Current playlist/chapter<br/><b>TRACK 01</b> Current track<br/><b>F001-T001</b> Current folder/track<br/><b>F001-F001</b> Current folder/file</p> | <p><b>5</b> Time indication<br/><b>TOTAL</b> Elapsed playing time of the disc<br/><b>T. REM</b> Remaining title time (for DVD)<br/>Remaining disc time (for others)<br/><b>TIME</b> Elapsed playing time of the current chapter/track *<sup>2</sup><br/><b>REM</b> Remaining time of the current chapter/track *<sup>2</sup></p> <p><b>6</b> Playback status<br/>▶ Play<br/>◀◀/▶▶ Reverse/forward search<br/>◀ /▶ Reverse/forward slow-motion<br/>   Pause<br/>■ Stop</p> <p><b>7</b> Operation icons<br/><b>TIME</b> Change time indication (see <b>5</b>)<br/>🕒➡ Time Search (Specify a certain scene by entering time.)<br/><b>TITLE➡</b> Title Search (by its number)<br/><b>CHAP➡</b> Chapter Search (by its number)<br/><b>GROUP➡</b> Group Search (by its number)<br/><b>TRACK➡</b> Track Search (by its number)<br/><b>RPT</b> Repeat play *<sup>1</sup><br/><b>INT</b> Intro play *<sup>1</sup><br/><b>RND</b> Random play *<sup>1</sup><br/>🔊 Change the audio language, audio stream, or audio channel<br/>🗣️ Change or erase the subtitle language<br/>📺 Change the view angle<br/><b>PAGE 1 / 7</b> Change the browsable still pictures (pages). The numbers in the indicator shows the current page/total page number</p> |
|---|---|

\*<sup>1</sup> 🗨️ page 18

\*<sup>2</sup> Not applicable for DVD-VR

# Dual Zone operations

You can enjoy a disc playback on the external monitor connected to the VIDEO OUT and 2nd AUDIO OUT plugs, while listening to any other source than "SD" and "USB" through the speakers.

- When Dual Zone is in use, you can only operate the DVD/CD player using the remote controller.

1

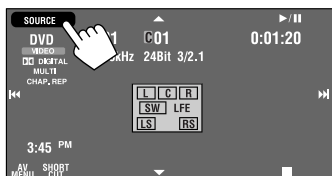

2

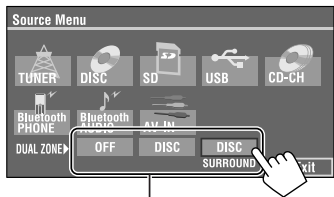

When the main source is "SD" or "USB," "DISC" and "DISC SURROUND" cannot be displayed.

- **OFF:** Deactivates Dual Zone.
- **DISC:** Activates Dual Zone without applying Headphone Surround\*.
- **DISC SURROUND:** Activates Dual Zone and applies Headphone Surround\*.

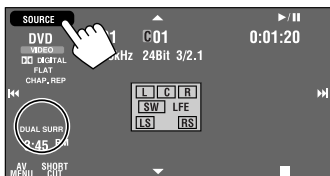

Ex. When [DISC SURROUND] is selected.

## To select a different source (main source) to listen through the speakers:

Press SOURCE on the monitor panel.

- You cannot select "SD" and "USB" for the main source.
- **By using the buttons on the monitor panel,** you can operate the newly selected main source without affecting Dual Zone (DISC) operations.

## On the remote controller:

1

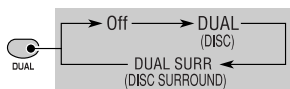

- When the main source is "SD" or "USB," the DUAL button does not work.

## 2 Adjust the volume through the 2nd AUDIO OUT plug.

2nd VOL



## 3 Operate the DVD/CD player.

\* JVC original headphone virtual surround system. This surround will also work for the main source "DISC" if "DISC SURROUND" is selected as the sub-source. This surround does not work for DivX/MPEG1/MPEG2 discs.

## Operations using the control screen

### For discs except DVD and VCD:

While Dual Zone is on, these operations are possible on the external monitor using the remote controller.

The control screen automatically appears when you insert a disc. (For DivX/MPEG1/MPEG2/JPEG; while not playing.)

- When Dual Zone is off, you can only watch the control screen, but cannot operate it.

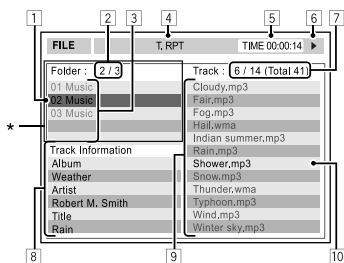

Ex.: MP3/WMA

- 1 Current folder (highlighted bar)
- 2 Current folder number/total folder number
- 3 Folder list
- 4 Selected playback mode (page 29)
- 5 Elapsed playing time of the current track (not displayed for JPEG)
- 6 Operation status
- 7 Current track number/total number of tracks in the current folder (total number of tracks on the disc)
- 8 Track information (only for MP3/WMA/WAV/AAC)
- 9 Track list
- 10 Current track (highlighted)

\* If tag data includes "Jacket Picture" (baseline JPEG), it will be displayed.

## To select a folder or track

- 1 Select "Folder" column or "Track" column on the control screen.



- 2 Select a folder or track.

- If necessary, press ENT to start playback.

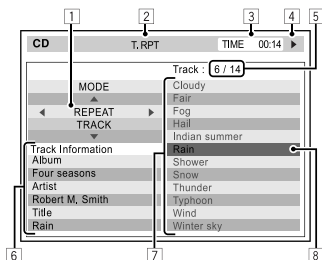

Ex.: CD Text

- 1 Playback mode selection window: appears when OSD is pressed (page 29).
- 2 Selected playback mode (page 29)
- 3 Elapsed playing time of the current track
- 4 Operation status
- 5 Current track number/total number of tracks on the disc
- 6 Track information
- 7 Track list
- 8 Current track (highlighted bar)

## To select a track



- If necessary, press ENT to start playback.

## To change the playback modes

You can also change the playback modes.

- For CD/MP3/WMA/WAV/AAC: Intro/Repeat/Random
- For DivX/MPEG1/MPEG2/JPEG: Repeat

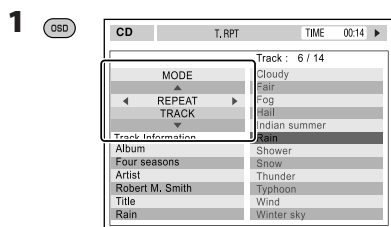

## 2 Only for CD/MP3/WMA/WAV/AAC: Select a playback mode.



## 3 Select your desired option.



## 4



### Selectable playback mode

CD: T. RPT: Track repeat  
A. RND: All random  
T. INT: Track intro

#### MP3/WMA/WAV/AAC:

T. RPT: Track repeat  
F. RPT: Folder repeat  
F. RND: Folder random  
A. RND: All random  
T. INT: Track intro  
F. INT: Folder intro

#### DivX/MPEG1/MPEG2:

T. RPT: Track repeat  
F. RPT: Folder repeat

#### JPEG:

F. RPT: Folder repeat

## Operations using the list screen

### For discs except DVD, VCD, and CD

While Dual Zone is on, these operations are possible on the external monitor using the remote controller.

## 1 After stopping playback, display the list screen.

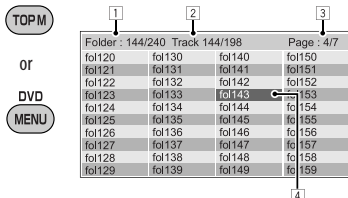

## 2 Select a folder on the list.

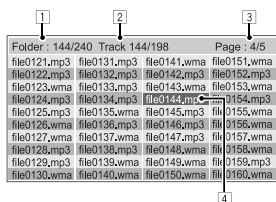

## 3 Select a track on the list.



- To go back to the folder list, press .

- 1 Current folder number/total folder number
- 2 Current track number/total number of tracks in the current folder
- 3 Current page/total number of the pages included in the list
- 4 Current folder/track (highlighted bar)

## SD operations

This unit can play the JPEG/MP3/WMA/WAV/AAC\*1 files stored in SD card.

- You can operate the SD card in the same way you operate the files on discs (except OSD operation and those on the external monitor). (\*1 page 15 to 25)
- All tracks in the SD card will be played repeatedly until you change the source.
- You cannot select "SD" when Dual Zone is in use.
- Make sure all important data has been backed up.

### 1 Open the monitor panel.

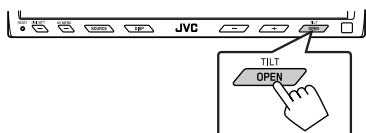

<Open/Tilt> menu appears.

- Shaded icons cannot be used at that time.

### 2 Press [OPEN].

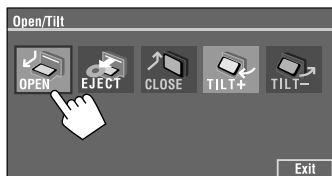

\*1 This unit can play back AAC files encoded using iTunes. This unit cannot play back AAC files purchased from the iTunes Store.

### 3 Insert a SD card.

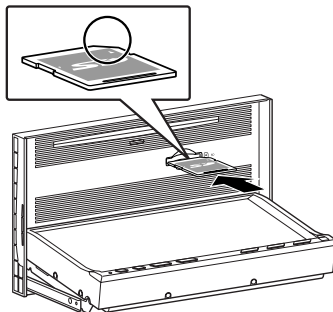

Push in the SD card until you hear a clicking sound. The source changes to "SD" and playback starts.

### 4 Close the monitor panel.

- If <Open/Tilt> menu is still displayed.

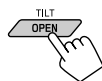

You can also press [CLOSE] on the <Open/Tilt> menu.

- If <Open/Tilt> menu is not displayed.

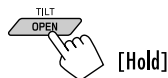

[Hold]

#### Caution:

Do not place your finger behind the monitor panel.

## To eject the SD card

Push in the SD card lightly.

#### Caution:

- Do not release your finger quickly; otherwise, the SD card may pop up from the loading slot.

## Selecting playback modes

You can use only one of the following playback modes—Intro/Repeat/Random.

Ex. To select Track Repeat



- You can also use AV MENU on the monitor panel.

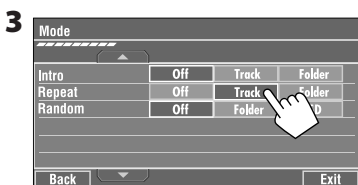
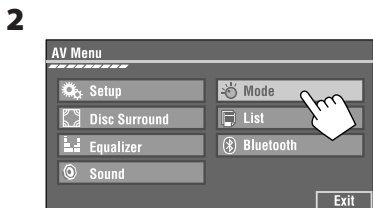

When one of the playback modes is selected, the corresponding indicator lights up on the source information screen.

To cancel, select <Off>.

File type	Intro	Repeat	Random
	<b>Track:</b> Plays the first 15 seconds of each track <b>Folder:</b> Plays the first 15 seconds of the first track of each folder	<b>Track:</b> Repeats current track *1 <b>Folder:</b> Repeats all tracks of the current folder	<b>Folder:</b> Randomly plays all tracks of current folder, then tracks of next folders <b>SD (All):</b> Randomly plays all tracks
	—	<b>Folder:</b> Repeats current folder	—

\*1 You can also use [SHORT CUT] to turn on and off Track Repeat.

## USB operations

You can connect a USB mass storage class device such as a USB memory, Digital Audio Player \*1, portable HDD, etc. to the unit.

1

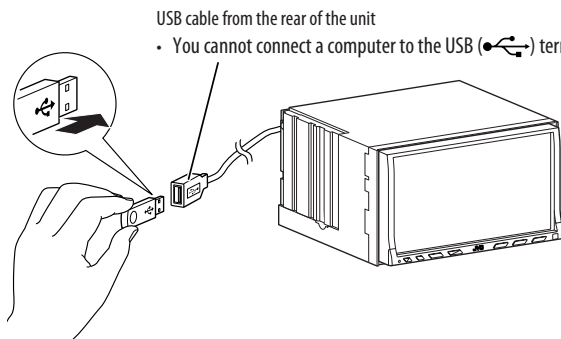

USB cable from the rear of the unit

- You cannot connect a computer to the USB (🔌) terminal of the unit.

2

Press [SOURCE], then press [USB]. (📖 page 9)

- You can also use SOURCE on the monitor panel. Press it repeatedly.

This unit can play the DivX/JPEG/MPEG1/MPEG2\*2/MP3/WMA/WAV/AAC\*3 files stored in USB mass storage class device.

- You can operate the USB device in the same way you operate the files on discs (except OSD operation and those on the external monitor). (📖 page 15 to 25)
- All tracks in the USB device will be played repeatedly until you change the source.
- You cannot select "USB" when Dual Zone is in use.
- Make sure all important data has been backed up.

\*1 Except for JVC D. Player XA-HD500.

\*2 Except for MPEG2 files recorded by JVC Everio camcorder (extension code <.mod>).

\*3 This unit can play back AAC files encoded using iTunes. This unit cannot play back AAC files purchased from the iTunes Store.

### Caution:

- Avoid using the USB device if it might hinder your safety driving.
- Do not pull out and attach the USB device repeatedly while "Now Reading..." is flashing on the monitor screen.
- Do not start the car engine if a USB device is connected.
- Stop playback before disconnecting a USB device.
- Do not leave a USB device in the car, expose to direct sunlight, or high temperature to avoid deformation or cause damages to the device.

## Selecting playback modes

You can use only one of the following playback modes—Intro/Repeat/Random.

Ex. To select Track Repeat



- You can also use AV MENU on the monitor panel.

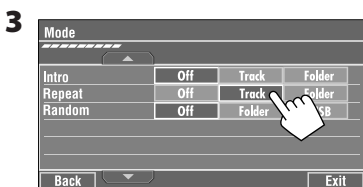
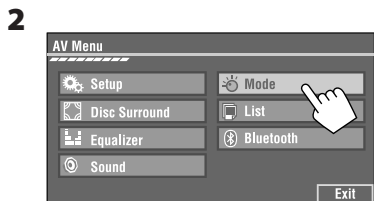

When one of the playback modes is selected, the corresponding indicator lights up on the source information screen.

To cancel, select <Off>.

File type	Intro	Repeat	Random
<b>MP3/WMA/ WAV/AAC</b>	<b>Track:</b> Plays the first 15 seconds of each track <b>Folder:</b> Plays the first 15 seconds of the first track of each folder	<b>Track:</b> Repeats current track *1 <b>Folder:</b> Repeats all tracks of the current folder	<b>Folder:</b> Randomly plays all tracks of current folder, then tracks of next folders <b>USB (All):</b> Randomly plays all tracks
<b>DivX</b>	—	<b>Track:</b> Repeats current track <b>Folder:</b> Repeats current folder	—
<b>MPEG</b>	—	<b>Folder:</b> Repeats current folder	—
<b>JPEG</b>	—	<b>Folder:</b> Repeats current folder	—

\*1 You can also use [SHORT CUT] to turn on and off Track Repeat.

# Bluetooth® operations — Cellular phone/audio player

For Bluetooth operations, it is required to connect the Bluetooth Adapter (KS-BTA200) to the CD changer jack on the rear.

- Refer also to the instructions supplied with the Bluetooth Adapter and the Bluetooth device.
- Refer to the list (included in the box) to see the countries where you may use the Bluetooth® function.

To use a Bluetooth device through the unit ("Bluetooth PHONE" and "Bluetooth AUDIO") for the first time, you need to establish Bluetooth wireless connection between the unit and the device.

- Once the connection is established, it is registered in the unit even if you reset your unit. Up to five devices can be registered in total.
- Only one device can be connected at a time for each source ("Bluetooth PHONE" and "Bluetooth AUDIO").

## Registering a Bluetooth device ■

### Registration (Pairing) methods

Use either of the following items in the <Bluetooth> menu to register and establish the connection with a device.

- Select "Bluetooth PHONE" or "Bluetooth AUDIO" as the source to operate the <Bluetooth> menu.

Menu item	To do
<b>Open</b>	Make the unit ready to establish a new Bluetooth connection. Connection is established by operating the Bluetooth device.
<b>Search</b>	Make the unit ready to establish a new Bluetooth connection. Connection is established by operating this unit.

## To register using <Open>

**Preparation:** Operate the device to turn on its Bluetooth function.

1



- You can also use AV MENU on the monitor panel.
- Make sure "New Device" is selected. If not, press [▲] or [▼] to select it.

2

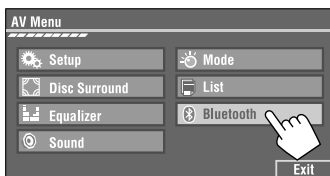

3



Go to other menu items

## 4 Enter a PIN (Personal Identification Number)\* code to the unit.

- You can enter any number you like (1-digit to 16-digit number).

\* Some devices have their own PIN code. Enter the specified PIN code to the unit.

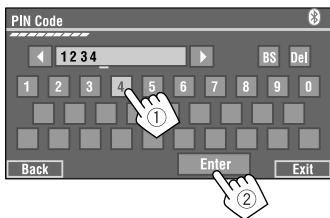

You can enter [0] – [9] only.

- [BS]: Erases the previous character before the cursor.
- [Del]: Erases the character on the cursor.
- [Enter]: Confirms the entry.

## 5 Use the Bluetooth device to connect, while “Open...” is displayed on the screen.

Enter the same PIN code (as entered in the above step) on the device to be connected.

Now connection is established and you can use the device through the unit.

The device remains registered even after you disconnect the device. Use <Connect> (or activate <Auto Connect>) to connect the same device from next time. (☞ the following, and page 59).

## To register using <Search>

- 1 Press [AV MENU] on the touch panel or AV MENU on the monitor panel.
  - Make sure “New Device” is selected. If not, press [▲] or [▼] to select it.
- 2 Press [Bluetooth].
- 3 Press [Search].
 

The unit searches for available devices and displays the list of them. (If no available device is detected, “Device Unfound” appears.)
- 4 Select a device you want to connect.
- 5 Enter the specific PIN code of the device.
  - Refer to the instructions supplied with the device to check the PIN code.
- 6 Use the Bluetooth device to connect, while “Connecting...” is displayed on the screen.

Now connection is established and you can use the device through the unit.

## To connect a special device <Special Device>

- 1 Press [AV MENU] on the touch panel or AV MENU on the monitor panel.
- 2 Press [Bluetooth].
- 3 Press [Special Device].
 

The unit displays the list of the preset devices.
- 4 Select a device you want to connect.
- 5 Use <Open> (or <Search>) to connect.

## To connect/disconnect a registered device

- 1 Select “Bluetooth PHONE” or “Bluetooth AUDIO,” then select a registered device you want to connect/disconnect.
- 2 Press [AV MENU] on the touch panel or AV MENU on the monitor panel.
- 3 Press [Bluetooth].
- 4 Press [Connect] or [Disconnect].
  - Select <Connect> to connect the selected device.
  - Select <Disconnect> to disconnect the selected device.

## To delete a registered device

- 1 Select “Bluetooth PHONE” or “Bluetooth AUDIO,” then select a registered device you want to delete.
- 2 Press [AV MENU] on the touch panel or AV MENU on the monitor panel.
- 3 Press [Bluetooth].
- 4 Press [Delete Pair].
 

Confirmation screen appears. Press [Yes].

# Using the Bluetooth cellular phone

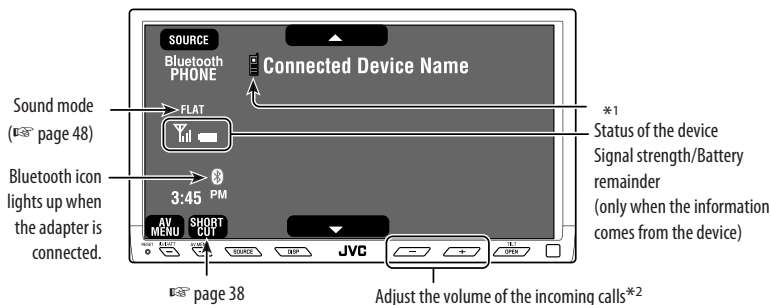

 : Buttons on the touch panel. In the explanation, they are indicated inside [ ].

[AV MENU] Hold: Activates <Voice Dialing>  
 [▲ ▼] Select the registered device ("New Device" appears when a new device can be registered.)

\*1 When a cellular phone with audio function is connected,  appears.

\*2 This adjustment does not affect the volume level of the other sources.

- 1 Press [SOURCE], then press [Bluetooth PHONE]. (page 9)
  - You can also use SOURCE on the monitor panel. Press it repeatedly.
- 2 Press [AV Menu].
  - You can also use AV MENU on the monitor panel.
- 3 Press [Bluetooth].
- 4 Establish the connection with a device, then make a call (or settings using the <Bluetooth> menu).

pages 58 and 59

## When a call comes in...

The source is changed to "Bluetooth PHONE" automatically.

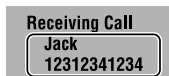

Name and phone number (if acquired)

## When <Auto Answer> is activated...

The unit answers the incoming calls automatically. (page 59)

## When <Auto Answer> is deactivated...

### To answer the incoming call

- Press any button on the monitor panel (except  / I / ATT or +/-).
- Press the message displayed on the touch panel.

### To end the call

- Hold any button on the monitor panel (except  / I / ATT or +/-).
- Hold the message displayed on the touch panel.
- You can adjust the microphone volume. (page 59)

## When an SMS comes in...

If the cellular phone is compatible with SMS (Short Message Service), you can read the messages on the monitor.

- You cannot edit or send a message through the unit.

## When <Message Info> is set to <Auto>...

The unit rings and the following screen is displayed on the monitor to inform you of the arrival of the message.

(☞ page 59)



To read the message, press [Yes].

The source is changed to "Bluetooth PHONE."

To read the message later, press [No].

- The message is stored into <Message> → <Unread>. (☞ page 58)

## When <Message Info> is set to <Manual>...

Access the message list to read a message. (☞ page 59)

## To make a call

1



- You can also use AV MENU on the monitor panel.

2

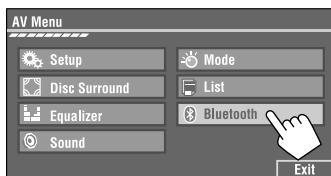

3



## 4 Select a calling method, then call.

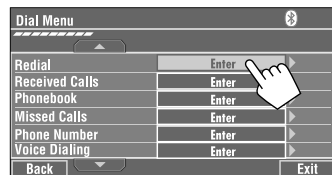

Cancel

- Redial:** Shows the list of the phone numbers you have dialed.
- Received Calls:** Shows the list of the received calls.
- Phonebook:** Shows the phone book of the connected cellular phone.
- Missed Calls:** Shows the list of the missed calls.
- Phone number:** Shows the phone number entry screen → "How to enter phone number" (☞ page 38).
- Voice Dialing:** (Only when the connected cellular phone has the voice recognition system): → Speak the name you want to call.

## To stop ringing (canceling the outgoing call)

Hold any button on the monitor panel (except  $\odot$ /I/ATT or +/−).

## How to enter phone number

- You cannot use the remote controller to enter phone numbers.



You can enter [0] – [9], [\*], [#] (up to 32 numbers)

- [BS]: Erases the previous character before the cursor.
- [Del]: Erases the character on the cursor.
- [Preset]: Goes to Preset List. You can preset the entered number by selecting preset number (see page 39)
- [Dial]: Calls the entered number.

- You can easily access <Dial Menu> by pressing [SHORT CUT] on the touch panel, then...

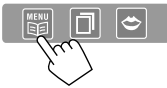

You can also access <Dial Menu> by holding SOURCE on the monitor panel.

- You can easily activate <Voice Dialing> by pressing [SHORT CUT] on the touch panel, then...



You can also activate <Voice Dialing> by holding [AV MENU].

## To redial the dialed numbers

1

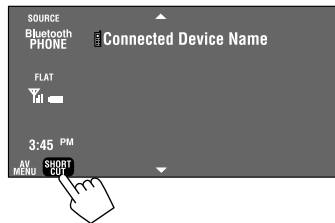

2

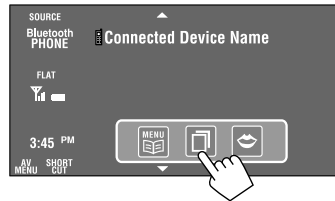

3

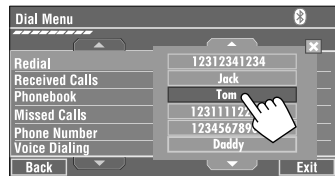

When using the remote controller, you can display <Redial> list anytime (except when Dual Zone is in use).



## Presetting the phone numbers

You can preset up to six phone numbers.

### 1 Select the phone number you want to preset from <Phonebook>, <Redial>, <Received Calls>, or <Missed Calls>.

- Press [AV MENU] on the touch panel or AV MENU on the monitor panel.
- Press [Bluetooth].
- Press [Dial Menu], then...

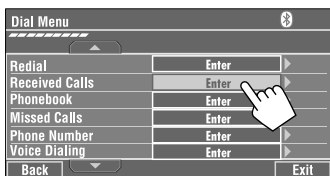

Ex.: Selecting <Received Calls>

### 2 Select a telephone number to store.

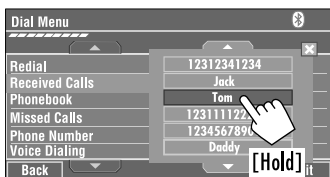

### 3 Select a preset number.

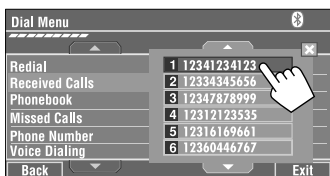

Now "Tom" is stored into preset no. 1.

## To call a preset number

1

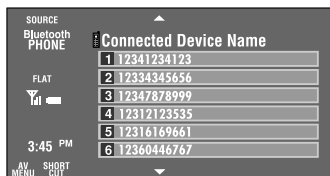
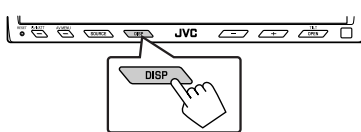

2

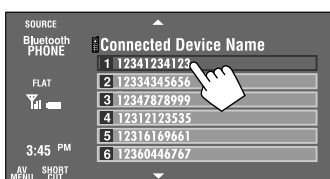

You can use the following buttons on the remote controller for the Bluetooth phone operations.



- Displays <Dial Menu>/Answer the incoming call.
- Displays <Redial> list if pressed and held (regardless of the current source).



: End the call.



: Adjust the volume.

1 2 3 : Make a call to the preset numbers.  
4 5 6

# Using the Bluetooth audio player

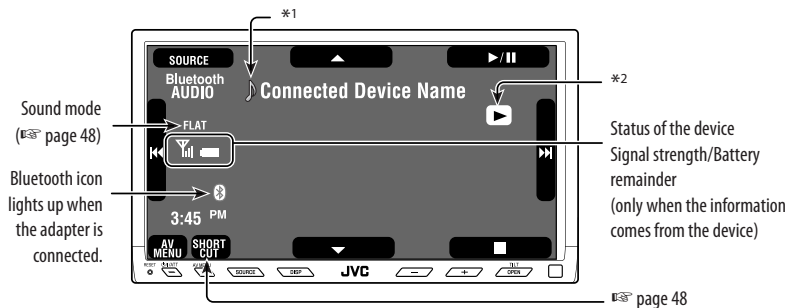

: Buttons on the touch panel. In the explanation, they are indicated inside [ ].

- Start and pause playback
- Reverse/forward search
- Select the registered device ("New Device" appears when a new device can be registered.)<sup>\*3</sup>

<sup>\*1</sup> When a cellular phone with audio function is connected, appears.

<sup>\*2</sup> Indicates the button pressed. It may be different from the operation status.

<sup>\*3</sup> You cannot select "New Device" when a Bluetooth audio player is connected.

## 1 Press [SOURCE], then press [Bluetooth AUDIO]. (page 9)

- You can also use SOURCE on the monitor panel. Press it repeatedly.

## 2 Start playback.

- See page 34 for connecting a new device.
- See pages 35 for connecting/disconnecting a registered device.
- See page 35 for deleting a registered device.

You can use the following buttons on the remote controller for the Bluetooth audio operations.

: Start and pause playback.

: Reverse/forward skip.

: Adjust the volume.

### Bluetooth Information:

If you wish to receive more information about Bluetooth, visit our JVC web site.



## Selecting playback modes

You can use only one of the following playback modes—Intro/Repeat/Random.

Ex. To select Track Repeat for an MP3 disc (for CDs, see page 18.)

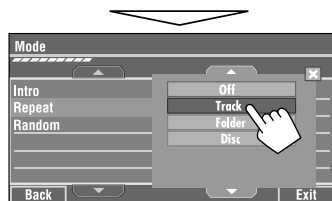

**1** Press [AV MENU] on the touch panel or AV MENU on the monitor panel.

**2** Press [Mode].



When one of the playback modes is selected, the corresponding indicator lights up on the source information screen.

To cancel, select <Off>.

Disc type	Intro	Repeat	Random
	<p><b>Track:</b> Plays the first 15 seconds of each track</p> <p><b>Disc:</b> Plays the first 15 seconds of the first track of all loaded discs</p>	<p><b>Track:</b> Repeats current track</p> <p><b>Disc:</b> Repeats all tracks of the current disc</p>	<p><b>Disc:</b> Randomly plays all tracks of the current disc</p> <p><b>All:</b> Randomly plays all tracks of all loaded discs</p>
	<p><b>Track:</b> Plays the first 15 seconds of each track</p> <p><b>Folder:</b> Plays the first 15 seconds of the first track of each folder</p> <p><b>Disc:</b> Plays the first 15 seconds of the first track of all loaded discs</p>	<p><b>Track:</b> Repeats current track</p> <p><b>Folder:</b> Repeats all tracks of the current folder</p> <p><b>Disc:</b> Repeats all tracks of the current disc</p>	<p><b>Folder:</b> Randomly plays all tracks of current folder, then tracks of next folders</p> <p><b>Disc:</b> Randomly plays all tracks of the current disc</p> <p><b>All:</b> Randomly plays all tracks of all loaded discs</p>

- You can easily turn on or off Track Repeat by pressing [SHORT CUT] on the touch panel, then...

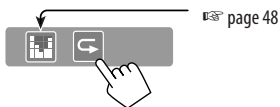

You can use the following buttons on the remote controller to operate the CD changer.

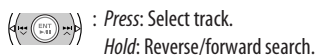
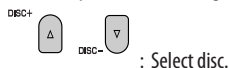

# Listening to the iPod/D. player

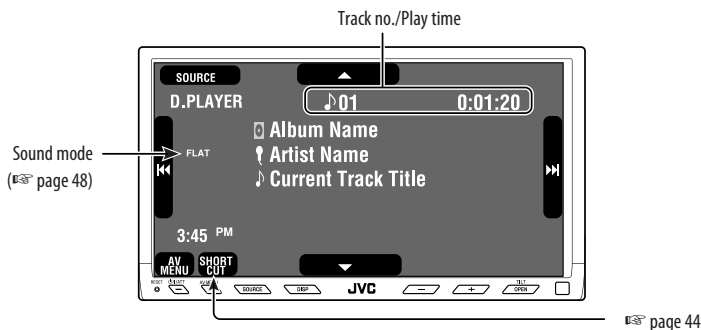

**[ ]** : Buttons on the touch panel. In the explanation, they are indicated inside [ ].

- [◀▶▶▶] Press: Select track  
Hold: Reverse/forward search
- [▲] Enter player's menu
- [▼] Pause/stop play  
• To resume, press again.

It is required to connect the interface adapter (KS-PD100 for Apple iPod or KS-PD500 for JVC D. player) to the CD changer jack on the rear.

## Preparation:

Make sure <iPod> or <D. player> is selected for <External Input>. (see page 56)

- 1 Press [SOURCE], then press [iPod] or [D.PLAYER] (see page 9)  
Playback starts automatically.

- You can also use SOURCE on the monitor panel. Press it repeatedly.

- 2 Press [◀◀] or [▶▶] to select a track.

## Selecting a track from the player's menu

- 1 Press [▲] to enter the player's menu.  
"SEARCH" flashes on the monitor during menu operations.
  - This mode will be canceled if no operations are done for about 5 seconds.
- 2 Press [◀◀] or [▶▶] to select the desired item.  
Press: Select an item.  
Hold: Skip 10 items at a time if more than 10 items.

### For iPod:

Playlists ↔ Artists ↔ Albums ↔ Songs  
↔ Genres ↔ Composers ↔ (back to the beginning)

### For D. player:

Playlist ↔ Artist ↔ Album ↔ Genre ↔  
Track ↔ (back to the beginning)

Continued on the next page

**3** Press [▼] to confirm the selection.

**4** Repeat steps 2 and 3 to select a track.

- When a track is selected finally, playback starts.
- To return to the previous menu, press [▲].

## Selecting playback modes

**1**

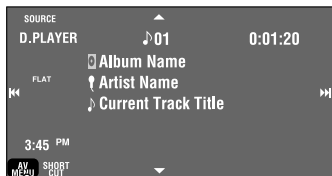

- You can also use AV MENU on the monitor panel.

**2**

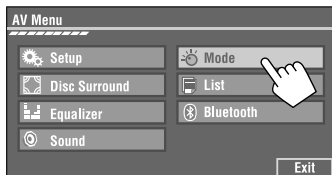

**3** Select an appropriate option.

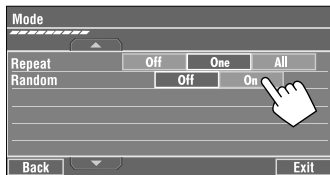

<b>Repeat</b>	<b>One:</b> Functions the same as “Repeat One” or “Repeat Mode → One.” <b>All:</b> Functions the same as “Repeat All” or “Repeat Mode → All.”
<b>Random</b>	<b>Album:</b> Functions the same as “Shuffle Albums” of the iPod. <b>Song/On:</b> Functions the same as “Shuffle Songs” or “Random Play → On.”

- When the playback modes are selected, the corresponding indicators lights up alternately on the monitor.

To cancel, select <Off>.

- You can easily turn on or off Track Repeat by pressing [SHORT CUT] on the touch panel, then...

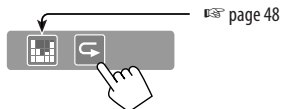

## Using other external components

### AV-INPUT

You can connect an external component to the LINE IN/VIDEO IN plugs.

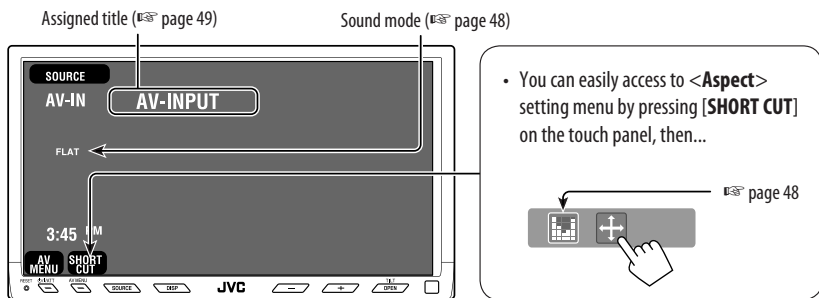

**[ ]** : Buttons on the touch panel. In the explanation, they are indicated inside [ ].  
 These buttons also work when they are not shown on the touch panel (while watching pictures on the screen).

- 1 Press [SOURCE], then press [AV-IN]. (page 9)
  - You can also use SOURCE on the monitor panel. Press it repeatedly.
- 2 Turn on the connected component and start playing the source.

### To display the operation buttons (page 17) while watching the playback picture

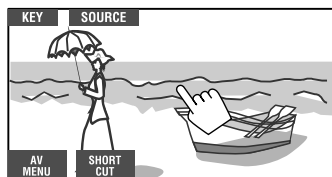
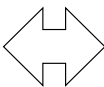

- If no operations are done for about 5 seconds, the operation buttons disappear.
- [KEY] does not work when the source is "AV-IN."

## Navigation screen

You can also connect a Navigation System to the VIDEO IN plug so that you can watch the navigation screen.

### Preparation:

Make sure **<Navigation>** is selected for **<AV Input>**. (☞ page 55)

### To view the navigation screen (and listen to the navigation guidance)\*

- 1 Press **DISP** on the monitor panel repeatedly. (☞ page 9)

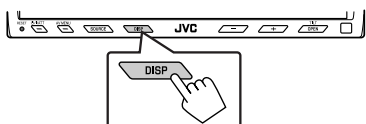

- The aspect ratio of the navigation screen is fixed to **<Full>** regardless of the **<Aspect>** setting (☞ page 52).

\* If your Navigation System is equipped with the voice guidance function.

### To display the operation buttons (☞ page 17) while viewing the navigation screen

- The operation buttons displayed on the screen vary among the playback sources.

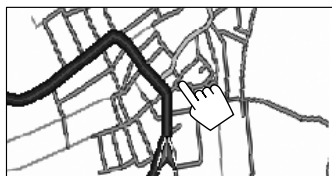

Touch the screen (center portion).

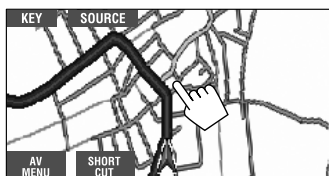
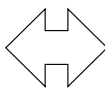

Touch the screen (center portion).

- If no operations are done for about 5 seconds, the operation buttons disappear.
- The above buttons except **[KEY]** also work when they are not shown on the touch panel (while viewing the navigation screen).

### When **<Navigation>** is selected for **<AV Input>**. (☞ page 55)

- You can use the source **<AV-IN>** for listening to an audio source connected to the **LINE IN** plugs.
- Some status messages such as volume level will not appear on the monitor.

## EXT-INPUT

You can connect an external component to the CD changer jack on the rear using the Line Input Adapter—KS-U57 (not supplied) or AUX Input Adapter—KS-U58 (not supplied).

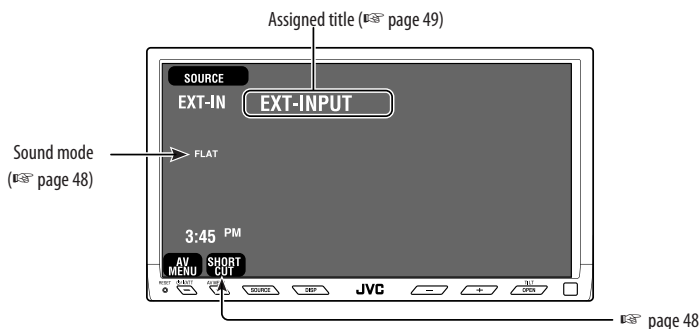

 : Buttons on the touch panel. In the explanation, they are indicated inside [ ].

### Preparation:

Make sure <External> is selected for <External Input>. (page 56)

- 1 Press [SOURCE], then press [EXT-IN]. (page 9)
  - You can also use SOURCE on the monitor panel. Press it repeatedly.
- 2 Turn on the connected component and start playing the source.

# Sound equalization

You can select a preset sound mode for 2-channel sources.

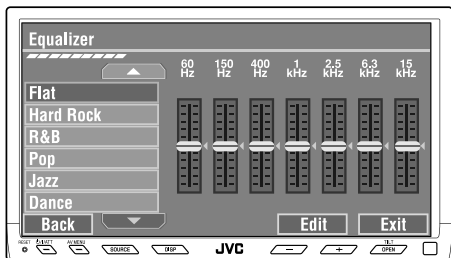

While playing any source other than "Bluetooth PHONE," <Equalizer> menu can be easily accessed by pressing [SHORT CUT] on the touch panel, then...



## Selecting sound mode



- You can also use AV MENU on the monitor panel.

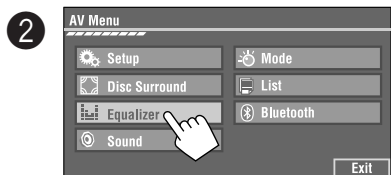

3

## Select a sound mode.

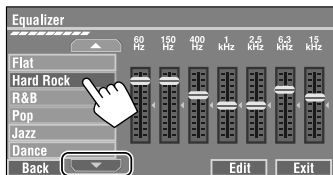

Move to other 6 sound modes

- For preset values of each sound mode, refer page 66.
- For multi-channel source, the sound mode is temporarily canceled.

## Storing your own adjustment

You can store your adjustment into User1, User2, and User3.

1 Repeat steps 1 and 2, then in step 3...

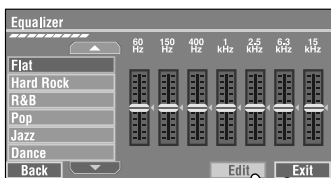

2 Adjust (1), then store (2).

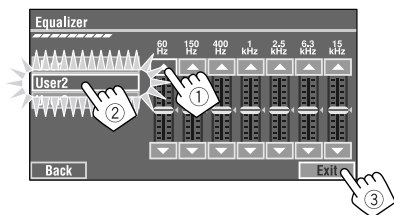

Ex. When storing into [User 2].

# Assigning titles to the sources

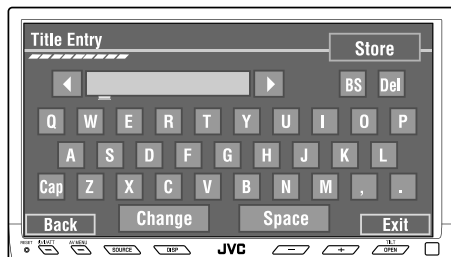

Buttons on the touch panel. In the explanation, they are indicated inside [ ] .

You can assign titles as follows.

<b>FM/AM stations</b>	Up to 16 characters—up to 30 stations.
<b>AV-IN EXT-IN</b>	Up to 16 characters

## 1 Select the source. (page 9)

- For FM/AM stations: Select the band, then tune into a station.

## 2 Display <Title Entry> screen.



- You can also use AV MENU on the monitor panel.

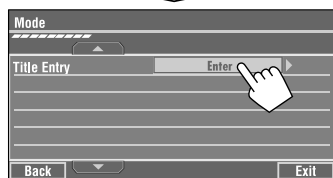
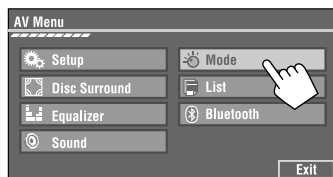

## 3 Assign a title.

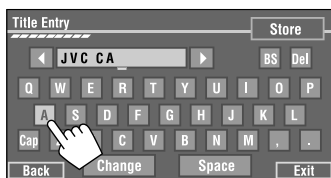

You can enter up to 16 characters (for available characters, page 65).

- [Store]: Confirm the entry.
- [<|>]: Moves the cursor.
- [BS]: Erases the previous character before the cursor.
- [Del]: Erases the character on the cursor.
- [Cap]: Changes the upper/lower cases.
- [Space]: Enter a space.
- [Change]: Change the character set.

## 4 Finish the procedure.



# Menu operations

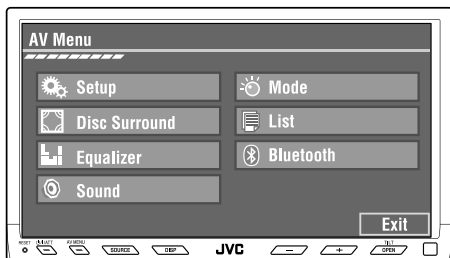

The following steps are one of the fundamental procedures. Some of the settings do not open the sub-setting window, but just selecting an option will change the setting.

Ex. Changing the <AV Input> setting



- You can also use AV MENU on the monitor panel.

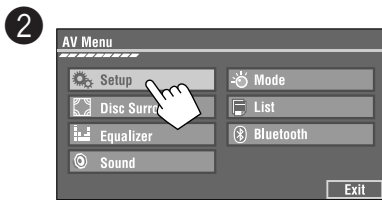

Non-available items will be displayed being shaded.

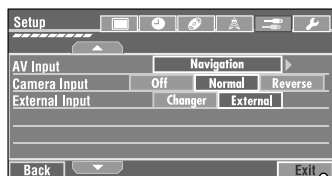
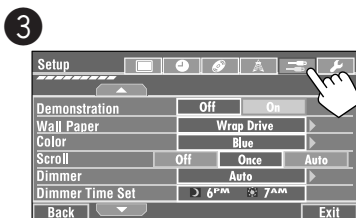



## Setup

Initial: Underlined











ENGLISH

Menu items	Selectable settings, [reference page]
Demonstration	<p><b>Off:</b> Cancels.</p> <p><b>On:</b> Activates the demonstration on the monitor. To stop it temporarily, touch the monitor screen.</p>
Wall Paper	<p>You can select the background picture of the monitor.</p> <p><b>Warp Drive, X-Face, Wave, Ring</b></p>
Color	<p>You can select the color of the &lt;Wall Paper&gt;.</p> <p><b>Blue, Sky, Green, Red, Yellow, Purple, Dark-Blue, Dark-Sky, Dark-Green, Dark-Red, Brown, Black</b></p>
Scroll	<p><b>Off:</b> Cancels.</p> <p><b>Once:</b> Scrolls the disc information once.</p> <p><b>Auto:</b> Repeats scrolling (5-second intervals).</p> <ul style="list-style-type: none"> <li>• Holding <b>DISP</b> on the monitor panel scrolls the information regardless of this setting.</li> </ul>
Dimmer	<p><b>Off:</b> Cancels.</p> <p><b>On:</b> Activates dimmer.</p> <p><b>Auto:</b> Dims the monitor when you turn on the headlights.*<sup>1</sup></p> <p><b>Dimmer Time Set :</b> Activates the Dimmer Time setting below.</p>
Dimmer Time Set	Sets the Dimmer On/Off times.
Dimmer Level	<p>You can preset the brightness for dimmer.</p> <p><b>00</b> (brightest) to <b>10</b> (darkest); Initial <b>05</b></p>
Bright	<p>You can adjust brightness of the monitor.</p> <p><b>-15</b> (darkest) to <b>+15</b> (brightest); Initial <b>00</b></p>
Picture Adjust* <sup>2</sup>	<p>You can adjust the following to make the monitor clear and legible for watching the playback picture. The setting will be stored—one for “DISC/SD/USB,” (common) and the other for “AV-IN.”</p> <p><b>-15</b> to <b>+15</b>; Initial <b>0</b></p> <p><b>Bright:</b> Adjust if the picture is too bright or too dark.</p> <p><b>Contrast:</b> Adjust the contrast.</p> <p><b>Color:</b> Adjust the color of the picture—lighter or darker.</p> <p><b>Tint:</b> Adjust the tint if the human skin color is unnatural.</p> <ul style="list-style-type: none"> <li>• Press [<b>▲</b>] or [<b>▼</b>] to adjust.</li> </ul>

\*<sup>1</sup> The ILLUMINATION CONTROL lead connection is required. (See Installation/Connection Manual)

\*<sup>2</sup> Adjustable only when the source is a disc/SD/USB containing pictures or movies, or “AV-IN.”

Continued on the next page

Menu items	Selectable settings, [reference page]		
<b>Aspect</b> * <sup>3</sup>   <b>Display</b>	You can change the aspect ratio of the picture.		
	<b>Aspect ratio of incoming signal</b>		
	<b>4:3</b>	<b>16:9</b>	
	<b>Regular:</b> For 4:3 original pictures 		
	<b>Full:</b> For 16:9 original pictures 		
<b>Panorama:</b> For viewing 4:3 pictures naturally on the wide screen 			
<b>Auto:</b>			<ul style="list-style-type: none"> <li>• For "DISC": Aspect ratio is automatically selected to match to the incoming signals.</li> <li>• For the other video sources: Aspect ratio is fixed to &lt;Regular&gt;.</li> </ul>
<b>Language</b> * <sup>4</sup>	Select the indication language shown on the monitor. <b>English, Spanish, French, German, Italian, Dutch, Swedish, Danish, Russian</b>		
<b>NTSC/PAL</b> * <sup>4</sup>	Select the color system of the external monitor connected— <b>NTSC, PAL</b> . <ul style="list-style-type: none"> <li>• Turn off the power and turn it on again to make the new setting effective.</li> </ul>		
<b>Time Set</b>	Initial <b>1:00AM</b> ,  [8]		
 <b>Clock</b>	Select either 12-hour system or 24-hour system. <b>12 Hours, 24 Hours</b> ,  [8]		
	<b>OSD Clock</b>	When <On> is selected, the clock time is displayed on the playback pictures. The clock time is displayed in large on the animation screen (  page 9) <b>Off, On</b>	

\*<sup>3</sup> Not adjustable when no picture is shown.

\*<sup>4</sup> After you change the indication language setting, turn off then on the power so that your setting takes effect.

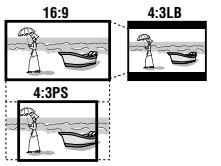
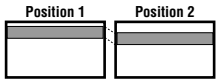
Menu items	Selectable settings, [reference page]
<b>Menu Language</b> * <sup>5</sup>	Select the initial disc menu language; Initial <b>English</b> (E <sup>3</sup> also page 66).
<b>Audio Language</b> * <sup>5</sup>	Select the initial audio language; Initial <b>English</b> (E <sup>3</sup> also page 66).
<b>Subtitle</b> * <sup>5</sup>	Select the initial subtitle language or erase the subtitle ( <b>Off</b> ); Initial <b>English</b> (E <sup>3</sup> also page 66).
<b>OSD Language</b> * <sup>5</sup>	Select the on-screen language used for the external monitor connected to the VIDEO OUT plug; Initial <b>English</b> .
<b>Monitor Type</b> * <sup>5</sup> 	Select the monitor type to watch a wide screen picture on the external monitor. <b>16:9</b> : Select when the aspect ratio of the external monitor is 16:9. <b>4:3LB</b> (Letterbox)/ <b>4:3PS</b> (Pan Scan): Select when the aspect ratio of the external monitor is 4:3. Refer to the illustrations on the left to see how the pictures are shown on the monitor.
<b>OSD Position</b> * <sup>5</sup> 	Select the position of the on-screen bar, E <sup>3</sup> [25]. <b>1</b> : Higher position <b>2</b> : Lower position
<b>File Type</b> * <sup>5</sup>	Select playback file type when a disc/SD/USB contains different types of files. You can store this setting separately for each source —“DISC/SD/USB.” <b>Audio</b> : Plays back audio files. <b>Picture</b> : Plays back JPEG files. <b>Video</b> : Plays back DivX/MPEG1/MPEG2 files. (Not applicable to “SD”)
<b>Divx Regist. (Registration)</b> * <sup>5</sup>	This unit has its own Registration Code. Once you have played back a file with which the Registration Code recorded, this unit’s Registration Code is overwritten for copyright protection.
<b>D. (Dynamic) Range Compres. (Compression)</b> * <sup>5</sup>	You can enjoy a powerful sound at a low volume level while playing Dolby Digital software. <b>Auto</b> : Select to apply the effect to multi-channel encoded software. <b>On</b> : Select to always use this function.

\*<sup>5</sup> Selectable only for “DISC,” “SD,” and “USB.” (Playback stops when you change the setting.)

Continued on the next page

## Menu items

## Selectable settings, [reference page]

## Speaker Size\*5

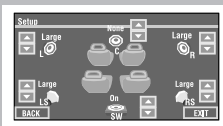

You can adjust the speaker size setting.

As you change the speaker size, the speaker on the screen changes its size. When <None> or <Off> is selected, the speaker is shaded.

- **L/R (Front): Small, Large**
- **C (Center): None, Small, Large**
- **LS/RS (Surround): None, Small, Large**
- **SW (Subwoofer): On, Off**
- Speaker size: <Large> for 13-cm diameter or more; <Small> for 13 cm or less.
- If you select <Large> or <Small> for non-connected speakers, the incoming signals for the non-connected speakers will not come out of any other speakers.
- Front speakers and surround speakers cannot be adjusted separately for left and right speakers.

**Regardless of the setting above...**

- No sound comes out of the subwoofer while playing Dolby Pro Logic II Movie or Music if the front speaker is set to <Large>.
- No sound comes out of the center speaker when surround is deactivated.

## Speaker Level\*6

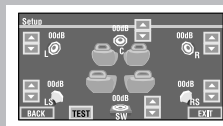

You can adjust the output level of the activated speakers (☞ <Speaker Size> above), monitoring the test tone.

**L/C/R/RS/SW\*7/LS:** adjust the output level of each speaker in the range of **-10dB** to **+10dB**; Initial **00dB**.

- Press [Test] to turn on and off the test tone.

## Speaker Distance\*6, 8

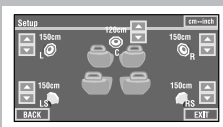

You can adjust the speaker output timing.

**L/C/R/RS/LS:** adjust the speaker distance from the listening position in the range of **15cm/6 inches** to **600 cm/240 inches** in 15-cm/6-inch step; Initial **120 cm/48 inches** (for center speaker), **150 cm/60 inches** (for other speakers).





- Press [cm↔inch] to change the measuring unit—**cm** and **inch**.

\*5 Selectable only for "DISC," "SD," and "USB." (Playback stops when you change the setting.)

\*6 Selectable only for "DISC," "SD," and "USB."

\*7 This subwoofer level setting takes effect only when surround is activated. (☞ also page 24)







\*8 This setting does not take effect for MPEG1/MPEG2 and DivX with MP3 audio track.

Menu items	Selectable settings, [reference page]
 Tuner	<b>IF Band Width</b> <b>Auto:</b> Increases the tuner selectivity to reduce interference noises between adjacent stations. (Stereo effect may be lost.) <b>Wide:</b> Subject to the interference from adjacent stations, but sound quality will not be degraded and the stereo effect will remain.
 Input	<b>AV Input*<sup>9</sup></b> You can determine the use of LINE IN and VIDEO IN plugs. <b>Off:</b> Select when no component is connected ("AV-IN" is skipped while selecting the source). <b>Audio&amp;video:</b> Select when connecting an AV component such as a VCR.  [45] <b>Audio:</b> Select when connecting an audio component such as a digital audio player.  [45] <b>Navigation :</b> Select when connecting a Navigation System.  [46]
<b>Camera Input*<sup>10</sup></b>	<b>Off:</b> Select when no rear view camera is connected to the CAMERA IN plug. <b>Normal:</b> Select when connecting the rear view camera to the CAMERA IN plug. The picture from the camera is displayed as it is taken. <b>Mirror:</b> The mirror image of the picture taken by the camera is displayed on the monitor. <ul style="list-style-type: none"> <li>• While the pictures through the camera are shown on the monitor, no message will be displayed.</li> </ul>

\*<sup>9</sup> Not selectable when "AV-IN" is selected as the source.

\*<sup>10</sup> Reverse lamp lead connection is required. See Installation/Connection Manual (separate volume). The rear view through the camera appears on the monitor in <Full> aspect ratio (regardless of the aspect ratio setting) when you shift the gear to the reverse (R) position. When you press DISP on the control panel, or when you shift the gear to another position other than the reverse (R) position, the rear view screen is cleared.

Continued on the next page

	Menu items	Selectable settings, [reference page]
Input 	<b>External Input</b> <sup>*11</sup>	For connecting an external component to the CD changer jack on the rear. <b>Changer/iPod/D. player</b> <sup>*12</sup> : CD changer, iPod, or D. player  [41, 43] <b>External</b> : Any other than the above.  [47] • For connecting the Bluetooth adapter, this setting is not required. It is automatically detected.
	<b>Beep</b>	<b>Off</b> : Cancels. <b>On</b> : Activates the key-touch tone.
Others 	<b>Telephone Muting</b> <sup>*13</sup>	<b>Off</b> : Cancels. <b>Muting1, Muting2</b> : Select either one which mutes the sounds while using the cellular phone.
	<b>Power LED Flash</b>	<b>Off</b> : Cancels. <b>On</b> : When the ignition is turned off, the lamp on the  /I/ATT button flashes.
	<b>TouchPanel Sens.</b>	Change the sensitivity of the touch panel. As the number decreases, sensitivity become higher. 1/2/3; Initial <u>2</u>
	<b>Initialize</b>	Initialize all settings you have made in <AV Menu>. Press and hold [ <b>Enter</b> ] to initialize the settings, then reset the unit (  page 3).





<sup>\*11</sup> Not selectable when the component connected to the CD changer jack is selected as the source.

<sup>\*12</sup> The name of the component detected through the CD changer jack is shown.

<sup>\*13</sup> The TEL MUTING lead connection is required. See Installation/Connection Manual (separate volume).



### Disc Surround<sup>\*14</sup>

Menu items	Selectable settings, [reference page]
<b>Surround</b>	<b>On, Off</b> ,  [24]
<b>Surround Mode</b>	<b>Auto, Through, Dolby PLII Movie, Dolby PLII Music</b> ,  [24]
<b>Panorama</b>	<b>On, Off</b> ,  [24]
<b>Center Width</b> <sup>*15</sup>	<b>00 to 07</b> ; Initial <b>04</b> ,  [25]

<sup>\*14</sup> Selectable only for "DISC", "SD," and "USB."

<sup>\*15</sup> This setting takes effect only when the center speaker is activated.



## Equalizer

Flat/Hard Rock/R&B/Pop/Jazz/Dance/Country/Reggae/Classic/User1/User2/User3, [48]

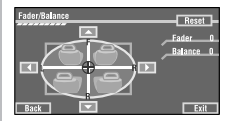

## Sound

Menu items	Selectable settings, [reference page]
<b>Fader/Balance</b> 	Adjust fader—speaker output balance between the front and rear speakers. <ul style="list-style-type: none"> <li>• Upmost—front only (F6)</li> <li>• Downmost—rear only (R6)</li> </ul> When using a two-speaker system, set the fader to the center ( <b>0</b> ). Adjust balance—speaker output balance between the left and right speakers. <ul style="list-style-type: none"> <li>• Leftmost—left only (L6)</li> <li>• Rightmost—right only (R6)</li> </ul>
<b>Volume Adjust</b>	Adjust and store auto-adjustment volume level for each source, comparing to the FM volume level. The volume level will automatically increase or decrease when you change the source. <b>-12 to +12; Initial 00</b> <ul style="list-style-type: none"> <li>• For Disc/SD/USB: An auto-adjustment level is commonly used when playing DivX/MPEG1/MPEG2/MP3/WMA/WAV/AAC files</li> </ul>
<b>Subwoofer Phase</b>	Select either < <b>Normal</b> > or < <b>Reverse</b> >, which reproduces a better sound.
<b>Subwoofer Level</b> <sup>*16</sup>	Adjust the subwoofer output level. Level: <b>-06 to +08; Initial 00</b>
<b>High Pass Filter</b>	<b>Through:</b> Select when the subwoofer is not connected. <b>On:</b> Select when the subwoofer is connected.
<b>Crossover</b>	Adjust the crossover frequency between the front/rear speakers and the subwoofer. <b>80Hz, 120Hz, 150Hz</b>
<b>Amplifier Gain</b>	You can change the maximum volume level of this unit. <b>Off:</b> Deactivates the built-in amplifier. <b>Low:</b> VOL 00 to 30 (Select this if the maximum power of the speakers is less than 50 W) <b>High:</b> VOL 00 to 50
<b>Rear Speaker</b> <sup>*17</sup>	You can activate/deactivate the rear speakers. <b>Off, On</b>

<sup>\*16</sup> This subwoofer level setting takes effect only when surround is deactivated. ( also page 24)

<sup>\*17</sup> This setting takes effect only when Dual Zone is activated. ( also page 27)

Continued on the next page

**Mode**\*18

Menu items	Selectable settings, [reference page]
<b>Mono</b>	Only for FM. ( <b>Off, On</b> ),  [10]
<b>DX/Local</b>	Only for FM. ( <b>Local, DX</b> ),  [11]
<b>SSM</b>	Only for FM. Press and hold to start SSM.  [11]
<b>Title Entry</b>	Only for FM/AM stations, AV-IN, and EXT-IN.  [49]
<b>Intro/Repeat/Random</b>	[18, 31, 33, 42, 44]

\*18 Items listed under <Mode> vary among the playback sources.

**List**

For "DISC": Folder List and Track List ( page 19)

For "CD-CH": Disc List, Folder List, and Track List ( page 41)

- For the other playback sources, you can display a list by pressing DISP on the monitor panel ( page 9)

**Bluetooth**\*19

Menu items	Selectable settings, [reference page]
<b>Dial Menu</b> *20	Select the method to make a call.  [37]
<b>Message</b> *21	You can read a message from the following message histories. <b>Unread:</b> Messages you have not read. <b>Read:</b> Messages you have read. <b>Unsent:</b> Messages you have not sent. <b>Sent:</b> Messages you have sent. <ul style="list-style-type: none"> <li>• The number of messages in each history is also shown on the monitor.</li> </ul>
<b>Open</b>	[34]
<b>Search</b>	[35]
<b>Special Device</b>	Only for "New Device." Shows the list of Bluetooth devices which require some special procedure to establish Bluetooth connection. Select a device you want to connect. <ul style="list-style-type: none"> <li>• After selecting the device, use &lt;Open&gt; or &lt;Search&gt; ( above) for connection.</li> <li>• Once the connection is established, it is registered in the unit. You can connect the unit and the device by using &lt;Connect&gt; ( page 59) from the next time.</li> </ul>

Menu items	Selectable settings, [reference page]
<b>Connect</b>	Only for the registered devices. After selecting a device from among the registered devices (☞ page 34, 35), establish the connection with it.
<b>Disconnect</b>	Only for the device being connected. Disconnect the current device before connecting another device.
<b>Delete Pair</b>	Only for the registered devices. Delete the registered devices.

\*19 Selectable only for "Bluetooth PHONE" or "Bluetooth AUDIO." Select a device (or "New Device") before operating the menu.

\*20 Only for the device connected for "Bluetooth PHONE."

\*21 Selectable only when the source is "Bluetooth PHONE" and the device is compatible with SMS (Short Message Service).

When operating the Bluetooth device, refer also to the instructions supplied with the device.

	Menu items	Selectable settings, [reference page]
<b>Settings</b>	<b>Auto Connect</b> *22	When the unit is turned on, the connection is established automatically with... <b>Off:</b> No Bluetooth device. <b>Last:</b> The last connected Bluetooth device. <b>Order:</b> The available registered Bluetooth device found at first.
	<b>Auto Answer</b> *23	<b>Off:</b> The unit does not answer the calls automatically. Answer the calls manually. <b>On:</b> The unit answers the incoming calls automatically. <b>Reject:</b> The unit rejects all incoming calls.
	<b>Message Info</b> *23	<b>Auto:</b> The unit informs you of the arrival of a message by ringing and displaying "Receiving Message." To read the message, ☞ page 37. <b>Manual:</b> The unit does not inform you of the arrival of a message.
	<b>MIC Setting</b> *23	Adjust microphone volume connected to the Bluetooth adapter. <b>01/02/03 Initial 02</b>
	<b>Version</b> *24	The Bluetooth software and hardware versions are shown.

\*22 Selectable only for "Bluetooth PHONE."

\*23 Only for the device connected for "Bluetooth PHONE." Not selectable when "New Device" is selected.

\*24 If you wish to receive more information about Bluetooth, visit our JVC web site.

# Maintenance

## Moisture condensation

Moisture may condense on the lens inside the unit in the following cases:

- After starting the heater in the car.
- If it becomes very humid inside the car.

Should this occur, the unit may malfunction. In this case, eject the disc and leave the unit turned on for a few hours until the moisture evaporates.

## How to handle discs

**When removing a disc from its case**, press down the center holder of the case and lift the disc out, holding it by the edges.

- Always hold the disc by the edges. Do not touch its recording surface.

**When storing a disc into its case**, gently insert the disc around the center holder (with the printed surface facing up).

- Make sure to store discs into the cases after use.

Center holder



## To keep discs clean

A dirty disc may not play correctly.

If a disc does become dirty, wipe it with a soft cloth in a straight line from center to edge.

- Do not use any solvent (for example, conventional record cleaner, spray, thinner, benzene, etc.) to clean discs.



## To play new discs

New discs may have some rough spots around the inner and outer edges. If such a disc is used, this unit may reject the disc.

To remove these rough spots, rub the edges with a pencil or ball-point pen, etc.



### Do not use the following discs:

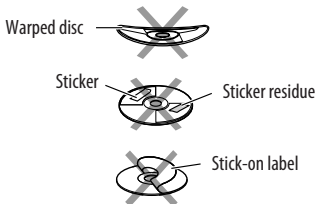

## More about this unit

### General

#### Turning on the power

- By pressing SOURCE on the monitor panel, you can also turn on the power. If the source is ready, playback starts.

### FM/AM

#### Storing stations in memory

- When SSM is over, received stations are preset in No. 1 (lowest frequency) to No. 6 (highest frequency).

### Disc

#### General

- In this manual, words “track” and “file” are interchangeably used.
- This unit can also play back 8 cm discs.
- This unit can only play back audio CD (CD-DA) files if different type of audio files (MP3/WMA/WAV/AAC) are recorded in the same disc.
- This unit can display only one-byte characters. No other characters can be correctly displayed.

#### Inserting a disc

- When a disc is inserted upside down or has no playable files, “Cannot play this disc Check the disc” appears on the monitor. Eject the disc.

#### Ejecting a disc

- If “No disc” appears after removing a disc, reattach a disc or select another playback source.
- If the ejected disc is not removed within 15 seconds, the disc is automatically inserted again into the loading slot to protect it from dust.

### Speaker/signal indicators for DVD

Speaker indicators	Signal indicators
L C R	L C R
SW	LFE
LS RS	LS S RS

- The speaker indicators—square around the letters lights in light blue when the corresponding speakers are set to <Large> or <Small>.
- The center speaker indicator—square around “C” lights in light blue, when the center speaker is set to <Large> or <Small> and when surround is activated.
- Sounds come out of the speakers whose speaker indicators are lit.
- The SW indicator lights up when <SW (Subwoofer)> is set to <On>.
- The signal indicators indicate the incoming signals—L (front left) / R (front right) / C (center) / LFE (low frequency effect) / LS (left surround) / RS (right surround) / S (monaural surround).
- If the speaker is activated, but the signals corresponding to the speaker are not coming in, the signal indicators changes their color from white to black to indicate no signals coming in.

#### Changing the source

- If you change the source with Dual Zone deactivated, playback also stops without ejecting the disc. Next time you select “DISC” for the playback source, disc play starts from where it has been stopped previously.

Continued on the next page

## Playing Recordable/Rewritable discs

- This unit can recognize a total of 5 000 files and 250 folders (a maximum of 999 files per folder).
- Use only “finalized” discs.
- This unit can play back multi-session discs; however, unclosed sessions will be skipped while playing.
- This unit can recognize a total 25 characters for file/folder names.
- Some discs or files may not be played back due to their characteristics or recording conditions.

## Playing DVD audio

- Some DVD Audios prohibit downmix. When you play back such a disc, “LR ONLY” appears on the monitor and the unit plays back the left front and right front signals.
- “MULTI CH” appears on the monitor after a beep when you try to play a multi-channel disc with Surround turned <Off>.

## Playing DVD-VR

- This unit cannot play back CPRM (Content Protection for Recordable Media) protected files.
- For details about DVD-VR format and play list, refer to the instructions supplied with the recording equipment.

## **■ File playback**

### Playing DivX files

- This unit can play back DivX files with the extension code <.divx>, <.div>, <.avi> (regardless of the letter case—upper/lower).
- This unit supports the DivX files whose resolution is 720 x 576 pixels or less.
- This unit supports DivX 6.x, 5.x, 4.x, and 3.11.
- Audio stream should conform to MP3 or Dolby Digital.
- The file encoded in the interlaced scanning mode may not be played back correctly.
- The maximum bit rate for video signals (average) is as follows.
  - DVD: 4 Mbps
  - USB: 2 Mbps

## Playing MPEG1/MPEG2 files

- This unit can play back MPEG1/MPEG2 files with the extension code <.mpg>, <.mpeg>, or <.mod>\*.
  - \* <.mod> is an extension code used for the MPEG2 files recorded by JVC Everio camcorders.
- The stream format should conform to MPEG system/program stream.
  - The file format should be MP@ML (Main Profile at Main Level)/SP@ML (Simple Profile at Main Level)/MP@LL (Main Profile at Low Level).
- Audio streams should conform to MPEG1 Audio Layer-2 or Dolby Digital.
- The maximum bit rate for video signals (average) is as follows.
  - DVD: 4 Mbps
  - USB: 2 Mbps

## Playing JPEG files

- This unit can play back JPEG files with the extension code <.jpg>, or <.jpeg>.
- It is recommended that you record a file at 640 x 480 resolution.
- This unit can play back baseline JPEG files. Progressive JPEG files or lossless JPEG files cannot be played.

## Playing MP3/WMA/WAV/AAC files

- This unit can play back files with the extension code <.mp3>, <.wma>, <.wav>, or <.m4a> (regardless of the letter case—upper/lower).
- This unit can play back the files meeting the conditions below:
  - Bit rate:
    - MP3/WMA: 32 kbps — 320 kbps
    - AAC: 16 kbps — 320 kbps
  - Sampling frequency:
    - 48 kHz, 44.1 kHz, 32 kHz (for MPEG1)
    - 24 kHz, 22.05 kHz, 16 kHz (for MPEG2)
    - 48 kHz, 44.1 kHz, 32 kHz, 22.05 kHz (for WMA)
    - 44.1 kHz (for WAV)
    - 48 kHz, 44.1 kHz (for AAC)

- This unit can show ID3 Tag Version 1.0/1.1/2.2/2.3/2.4 (for MP3). This unit can also show WAV/WMA/AAC Tag.
- This unit can play back files recorded in VBR (variable bit rate).
- Files recorded in VBR have a discrepancy in elapsed time indication.
- This unit cannot play back the following files:
  - MP3 files encoded with MP3i and MP3 PRO format.
  - MP3 files encoded with Layer 1/2.
  - WMA files encoded with lossless, professional, and voice format.
  - WMA files which are not based upon Windows Media® Audio.
  - WMA/AAC files copy-protected with DRM.
  - AAC files encoded by using any other application than iTunes.
  - AAC files purchased from the iTunes Store.
  - Files which have the data such as AIFF, ATRAC3, etc.

### Enjoying surround sounds

- If <Surround> is set to <On>, “MULTI” surround playback automatically starts for multi-channel encoded discs.
- You cannot activate surround for MPEG multi-channel DVD Video, DivX 2-channel and MPEG 2-channel sources. If <Surround> is set to <On>, stereo sounds are emitted only through the front speakers. “FRONT 2CH” appears on the source information screen.
- When “FIX” appears on the source information screen, no sound comes out of the subwoofer.
- When If <Surround> is set to <Auto>, downsampling is performed for DVD Video (LPCM only), DVD-VR (LPCM only), and DVD Audio with fs=88.2 kHz/96 kHz and higher.

### SD

- If “No SD Card” appears after removing an SD card, reattach an SD card or select another playback source.

- When the SD card has no playable files, or has not been formatted correctly, “Cannot play this SD card Check the SD card” appears on the monitor. Replace the SD card. Do not pull out or attach the SD card while “Now Reading...” is shown on the monitor.
- This unit can recognize a total of 5 000 files and 250 folders (a maximum of 999 files per folder).
- This unit can recognize a total 25 characters for file/folder names.

### USB

- If “No USB Device” appears after removing a device, reattach a device or select another playback source.
- When the USB device has no playable files, or has not been formatted correctly, “Cannot play this device Check the device” appears on the monitor.
- The unit cannot recognize a USB device whose rating is other than 5 V and does not exceed 500 mA.
- While playing from a USB device, the playback order may differ from other players.
- This unit may be unable to play back some USB devices or some files due to their characteristics or recording conditions.
- Depending on the shape of the USB devices and connection ports, some USB devices may not be attached properly or the connection might be loose.
- When connecting a USB device, refer also to its instructions.
- Connect only one USB device to the unit at a time. Do not use a USB hub.
- This unit may not recognize a USB device connected through a USB card reader.
- This unit may not play back files in a USB device properly when using a USB extension cord.
- This unit cannot assure proper functions or supply power to all types of the devices.
- This unit can recognize a total of 5 000 files and 250 folders (a maximum of 999 files per folder).
- This unit can recognize a total 25 characters for file/folder names.

Continued on the next page

## Bluetooth operations

### General





- While driving, do not perform complicated operation such as dialing the numbers, using phone book, etc. When you perform these operations, stop your car in a safe place.
- Some Bluetooth devices may not be connected to this unit depending on the Bluetooth version of the device.
- This unit may not work for some Bluetooth devices.
- Connecting condition may vary depending on circumstances around you.
- When the unit is turned off, the device is disconnected.

### Warning messages for Bluetooth operations

- **Connection Error:** The device is registered but the connection has failed. Use <Connect> to connect the device again. (☞ page 35)
- **Error:** Try the operation again. If "Error" appears again, check if the device supports the function you have tried.
- **Device Unfound:** No available Bluetooth device is detected by <Search>.
- **Loading:** The unit is updating the phone book and/or SMS.
- **Please Wait...:** The unit is preparing to use the Bluetooth function. If the message does not disappear, turn off and turn on the unit, then connect the device again (or reset the unit).
- **Reset 08:** Check the connection between the adapter and this unit.

### Icons for phone types

- These icons indicate the phone type set on the device.

	: Cellular phone
	: Household phone
	: Office
	: General
	: Other than above

### CD changer

- If you select a folder, which does not include any music files, on the list (☞ page 41), you will hear a beep. Select another folder including music files.

### iPod/D. player operations

- When you turn on this unit, the iPod or D. player is charged through the adapter connected to this unit.
- While the iPod or D. player is connected, all operations from the iPod or D. player are disabled. Perform all operations from this unit.
- The text information may not be displayed correctly.
- If the text information includes more than 8 characters, it scrolls on the display. This unit can display up to 40 characters.

#### Notice:

When operating an iPod or a D. player, some operations may not be performed correctly or as intended. In this case, visit the following JVC web site:

**For iPod users:** <<http://www.jvc.co.jp/english/car/support/ks-pd100/index.html>>

**For D. player users:** <<http://www.jvc.co.jp/english/car/support/ks-pd500/index.html>>

## Menu settings

- If you change the <Amplifier Gain> setting from <High> to <Low> while the volume level is set higher than "30," the unit automatically changes the volume level to "VOL 30."
- After you change any of <Menu Language/Audio Language/Subtitle> settings, turn off then on the power, and re-insert the disc (or insert another disc) so that your setting takes effect.
- When you select <16:9> for a picture whose aspect ratio is 4:3, the picture slightly changes due to the process for converting the picture width.
- Even if <4:3PS> is selected, the screen size may become <4:3LB> for some discs.

- "DVD Logo" is a trademark of DVD Format/Logo Licensing Corporation registered in the US, Japan and other countries.
- DivX, DivX Ultra Certified, and associated logos are trademarks of DivX, inc. and are used under license.
- Official DivX® Ultra Certified product
- Plays all versions of DivX® video (including DivX® 6) with enhanced playback of DivX® media files and the DivX® Media Format
- Microsoft and Windows Media are either registered trademarks or trademarks of Microsoft Corporation in the United States and/or other countries.
- The Bluetooth word mark and logos are owned by the Bluetooth SIG, Inc. and any use of such marks by Victor Company of Japan, Limited (JVC) is under license. Other trademarks and trade names are those of their respective owners.
- iPod and iTunes are trademarks of Apple Inc., registered in the U.S. and other countries.
- This product incorporates copyright protection technology that is protected by U.S. patents and other intellectual property rights. Use of this copyright protection technology must be authorized by Macrovision, and is intended for home and other limited viewing uses only unless otherwise authorized by Macrovision. Reverse engineering or disassembly is prohibited.

## Characters shown on the monitor

In addition to the roman alphabet (A – Z, a – z), and < , (comma)>, and < . (period)>, the following characters will be used to show the various information on the monitor.

- You can also use the following characters to assign titles. (☞ page 49).

Á	À	Â	Ã	Ä
Å	Æ	Ç	Ĉ	Ć
Ç	É	È	Ê	Ë
Ĝ	Í	Ì	Î	Ï
Ñ	Ó	Ô	Õ	Ö
Õ	Ø	Ř	Ŕ	Š
Š	Ş	Ú	Û	Ü
Û	Ý	Ž	Ẓ	Ẕ
Ẓ	Ẕ	Ẕ	Ẕ	Ẕ
ı	ı	ı		

á	à	â	ã	ä
å	æ	œ	ç	ć
ç	é	è	ê	ë
ě	ĝ	í	ì	ï
ĩ	ñ	ň	ń	ó
ò	ó	ô	õ	ö
ő	ř	ŕ	š	ś
ş	ú	û	ü	ű
ú	w	y	ÿ	ÿ
ẑ	ẓ	Ẕ	ẕ	đ
ı	ı	ı	ıj	

Upper and lower cases

0	1	2	3	4
5	6	7	8	9
!	"	#	\$	%
&	'	(	)	`
=	-	+	*	/
@	?	;	:	

Numbers and symbols

## Language codes (for DVD/DivX language selection)

Code	Language	Code	Language	Code	Language	Code	Language	Code	Language
AA	Afar	FA	Persian	KL	Greenlandic	OC	Occitan	ST	Sesotho
AB	Abkhazian	FI	Finnish	KM	Cambodian	OM	(Afan) Oromo	SU	Sundanese
AF	Afrikaans	FJ	Fiji	KN	Kannada	OR	Oriya	SW	Swahili
AM	Ameharic	FO	Faroese	KO	Korean (KOR)	PA	Panjabi	TA	Tamil
AR	Arabic	FY	Frisian	KS	Kashmiri	PL	Polish	TE	Telugu
AS	Assamese	GA	Irish	KU	Kurdish	PS	Pashto, Pushto	TG	Tajik
AY	Aymara	GD	Scots Gaelic	KY	Kirghiz	PT	Portuguese	TH	Thai
AZ	Azerbaijani	GL	Galician	LA	Latin	QU	Quechua	TI	Tigrinya
BA	Bashkir	GN	Guarani	LN	Lingala	RM	Rhaeto-Romance	TK	Turkmen
BE	Byelorussian	GU	Gujarati	LO	Laothian	RN	Kirundi	TL	Tagalog
BG	Bulgarian	HA	Hausa	LT	Lithuanian	RO	Rumanian	TN	Setswana
BH	Bihari	HI	Hindi	LV	Latvian, Lettish	RW	Kinyarwanda	TO	Tonga
BI	Bislama	HR	Croatian	MG	Malagasy	SA	Sanskrit	TR	Turkish
BN	Bengali, Bangla	HU	Hungarian	MI	Maori	SD	Sindhi	TS	Tsonga
BO	Tibetan	HY	Armenian	MK	Macedonian	SG	Sangho	TT	Tatar
BR	Breton	IA	Interlingua	ML	Malayalam	SH	Serbo-Croatian	TW	Twi
CA	Catalan	IE	Interlingue	MN	Mongolian	SI	Singhalese	UK	Ukrainian
CO	Corsican	IK	Inupiak	MO	Moldavian	SK	Slovak	UR	Urdu
CS	Czech	IN	Indonesian	MR	Marathi	SL	Slovenian	UZ	Uzbek
CY	Welsh	IS	Icelandic	MS	Malay (MAY)	SM	Samoan	VI	Vietnamese
DZ	Bhutani	IW	Hebrew	MT	Maltese	SN	Shona	VO	Volapuk
EL	Greek	JI	Yiddish	MY	Burmese	SO	Somali	WO	Wolof
EO	Esperanto	JW	Javanese	NA	Nauru	SQ	Albanian	XH	Xhosa
ET	Estonian	KA	Georgian	NE	Nepali	SR	Serbian	YO	Yoruba
EU	Basque	KK	Kazakh	NO	Norwegian	SS	Siswati	ZU	Zulu

Sound mode	Preset equalizing values						
	60 Hz	150 Hz	400 Hz	1 kHz	2.5 kHz	6.3 kHz	15 kHz
Flat	00	00	00	00	00	00	00
Hard Rock	+03	+03	+01	00	00	+02	+01
R&B	+03	+02	+02	00	+01	+01	+03
Pop	00	+02	00	00	+01	+01	+02
Jazz	+03	+02	+01	+01	+01	+03	+02
Dance	+04	+02	00	-02	-01	+01	+01
Country	+02	+01	00	00	00	+01	+02
Reggae	+03	00	00	+01	+02	+02	+03
Classic	+02	+03	+01	00	00	+02	00
User 1/2/3	00	00	00	00	00	00	00

### About sounds reproduced through the rear terminals

- Speaker out/analog discrete output—LINE OUT (FRONT/REAR)/CENTER OUT/SUBWOOFER: Multi-channel signals are emitted for a multi-channel encoded software. (When Dual Zone is activated, the signal emitted through 2nd AUDIO OUT plugs are emitted for the main source "DISC.")
- 2nd AUDIO OUT: 2-channel signal is emitted when Dual Zone is activated. When playing a multi-channel encoded disc, multi-channel signals are downmixed (except for some DVD Audio).

# Troubleshooting

What appears to be trouble is not always serious. Check the following points before calling a service center.

- For operations with the external components, refer also to the instructions supplied with the adapters used for the connections (as well as the instructions supplied with the external components).

	Symptoms	Remedies/Causes
General	• No sound comes out of the center speaker.	<ul style="list-style-type: none"> <li>• Center speaker is not activated. (☞ page 54)</li> <li>• Center speaker is used only for surround playback. No sound comes out for stereo playback.</li> </ul>
	• No sound comes out of the rear speakers, and subwoofer.	<ul style="list-style-type: none"> <li>• Rear speakers and subwoofer are not activated. (☞ page 54)</li> <li>• When Dual Zone is in use, this is normal with &lt;Off&gt; selected for &lt;Rear Speaker&gt;. (☞ page 57)</li> </ul>
	• No sound comes out of the subwoofer while playing in stereo.	This happens while playing some discs with <Auto> selected for <Surround Mode> (☞ page 24). Cancel surround.
	• The monitor is not clear and legible.	Sunshine from the windshield may cause this symptom. Adjust <Bright>. (☞ page 51)
	• You cannot select "SD" and "USB" as the source.	Deactivate Dual Zone. (☞ page 27) (While Dual Zone is activated, you cannot select them as the source.)
	• The remote controller does not work.	Deactivate Dual Zone. (☞ page 27) (While Dual Zone is activated, the remote controller only functions for operating the DVD/CD player.)
	• "Position Error Push Open Key" appears on the monitor.	The monitor panel angle has been forcibly adjusted, or its adjustment has been interrupted while opening or closing. Press OPEN/TILT (CLOSE).
	• "Mecha Error Push Reset" appears on the monitor, and the panel does not move.	Reset the unit (☞ page 3).
	• "SD Loading Error" appears on the monitor.	SD is not inserted fully. Fully insert it into the slot to close the monitor panel.

Continued on the next page

	Symptoms	Remedies/Causes
General	<ul style="list-style-type: none"> <li>• “No Signal” appears.</li> </ul>	<ul style="list-style-type: none"> <li>• Change the source.</li> <li>• Start the playback on the external component connected to VIDEO IN plug.</li> <li>• Check the cords and connections.</li> <li>• Signal input is too weak.</li> </ul>
	<ul style="list-style-type: none"> <li>• The buttons on the monitor panel do not work.</li> </ul>	When the monitor panel is open, only VOL +/- and OPEN/TILT (CLOSE) button work. The other buttons do not function.
	<ul style="list-style-type: none"> <li>• The unit does not work at all.</li> </ul>	Reset the unit. (☞ page 3)
FM/AM	<ul style="list-style-type: none"> <li>• SSM automatic presetting does not work.</li> </ul>	Store stations manually. (☞ page 11)
	<ul style="list-style-type: none"> <li>• Static noise while listening to the radio.</li> </ul>	Connect the aerial firmly.
Disc in general	<ul style="list-style-type: none"> <li>• Disc can be neither recognized nor played .</li> </ul>	Eject the disc forcibly. (☞ page 3)
	<ul style="list-style-type: none"> <li>• Disc cannot be ejected.</li> </ul>	Unlock the disc. (☞ page 19)
	<ul style="list-style-type: none"> <li>• Recordable/Rewritable discs cannot be played back.</li> <li>• Tracks on the Recordable/Rewritable discs cannot be skipped.</li> </ul>	<ul style="list-style-type: none"> <li>• Insert a finalized disc.</li> <li>• Finalize the discs with the component which you used for recording.</li> </ul>
	<ul style="list-style-type: none"> <li>• Playback does not start.</li> </ul>	<ul style="list-style-type: none"> <li>• Insert the disc correctly again.</li> <li>• The format of files is not supported by the unit.</li> </ul>
	<ul style="list-style-type: none"> <li>• The playback picture is not clear and legible.</li> </ul>	Adjust items in <Picture Adjust>. (☞ page 51)
	<ul style="list-style-type: none"> <li>• Sound and pictures are sometimes interrupted or distorted.</li> </ul>	<ul style="list-style-type: none"> <li>• Stop playback while driving on rough roads.</li> <li>• Change the disc.</li> </ul>
	<ul style="list-style-type: none"> <li>• No playback picture appears on the monitor.</li> </ul>	Parking brake lead is not connected properly. (☞ Installation/Connection Manual)
	<ul style="list-style-type: none"> <li>• No picture appears on the external monitor.</li> </ul>	<ul style="list-style-type: none"> <li>• Connect the video cord correctly.</li> <li>• Select the correct input on the external monitor.</li> </ul>
	<ul style="list-style-type: none"> <li>• “Eject Error” or “Loading Error” appears on the monitor.</li> </ul>	Changing the source by pressing SOURCE will solve this error.
	<ul style="list-style-type: none"> <li>• “Region code error” appears on the monitor when you insert a DVD Video.</li> </ul>	Region code is not correct. (☞ page 4)

	Symptoms	Remedies/Causes
DivX/MPEG1/MPEG2/PEG/MP3/WMA/WAV/AAC	• Disc cannot be played back.	<ul style="list-style-type: none"> <li>• Change the disc.</li> <li>• Record the tracks using a compliant application in the appropriate discs. (☞ page 4)</li> <li>• Add appropriate extension codes to the file names.</li> </ul>
	• Noise is generated.	The track played back is not a playable file format. Skip to another file.
	• Tracks are not played back as you have intended them to play.	Playback order may differs from the one played back using other players.
	• Elapsed playing time is not correct.	This sometimes occurs during playback. This is caused by how the tracks are recorded.
	• “Not Support” appears on the monitor and track skips.	The track is unplayable.
SD/USB	• Noise is generated.	The track played back is not a playable file format. Skip to another file.
	• Tracks cannot play back as you have intended them to play.	Playback order may differs from the one played back using other players.
	• “Now Reading...” keeps flashing on the monitor.	<ul style="list-style-type: none"> <li>• Readout time varies depending on the SD card/USB device.</li> <li>• Do not use too many hierarchy and folders.</li> <li>• Turn off the power then on again.</li> </ul>
	• Correct characters are not displayed (e.g. album name).	For available characters, ☞ page 65.
	• While playing a track, sound is sometimes interrupted.	The tracks are not properly copied into the SD card/USB device. Copy tracks again, and try again.

Continued on the next page

	Symptoms	Remedies/Causes
Bluetooth	• Bluetooth device does not detect the unit.	This unit can be connected with one Bluetooth cellular phone and one Bluetooth audio device at a time. While connecting a device, this unit cannot be detected from another device. Disconnect currently connected device and search again.
	• The unit does not detect the Bluetooth device.	<ul style="list-style-type: none"> <li>• Check the Bluetooth setting of the device.</li> <li>• Search from the Bluetooth device. After the device detects the unit, select &lt;Open&gt; on the unit to connect the device. (☞ page 34)</li> </ul>
	• The unit does not make pairing with the Bluetooth device.	<ul style="list-style-type: none"> <li>• Enter the same PIN code for both the unit and target device. If the PIN code of the device is not indicated on its instructions, try "0000" or "1234."</li> <li>• Select the device name from &lt;Special Device&gt;, then try to connect again. (☞ pages 35, 58)</li> </ul>
	• Echo or noise occurs.	Adjust the microphone unit position.
	• Phone sound quality is poor.	<ul style="list-style-type: none"> <li>• Reduce the distance between the unit and the Bluetooth audio device.</li> <li>• Move the car to place where you can get a better signal reception.</li> </ul>
	• The sound is interrupted or skipped during playback of a Bluetooth audio device.	<ul style="list-style-type: none"> <li>• Reduce the distance between the unit and the Bluetooth audio device.</li> <li>• Disconnect the device connected for "Bluetooth PHONE."</li> <li>• Turn off, then turn on the unit.</li> <li>• (When the sound is not yet restored,) connect the device again.</li> </ul>
	• "New Device" cannot be selected for "Bluetooth AUDIO."	Bluetooth audio device is being connected. To select "New Device," disconnect it. (☞ page 35)
	• The connected audio device cannot be controlled.	Check whether the connected audio device supports AVRCP (Audio Video Remote Control Profile).
	• "Reset 08" appears on the monitor.	Check the connection between the adapter and this unit.
	CD changer	• "No Disc" appears on the monitor.
• "No Magazine" appears on the monitor.		Insert the magazine.
• "Cannot play this disc Check the disc" appears on the monitor.		Disc does not include playable files. Replace the disc with playable files.
• "Reset 08" appears on the monitor.		Connect this unit and the CD changer correctly and press the reset button of the CD changer.
• "Reset 01" – "Reset 07" appears on the monitor.		Press the reset button of the CD changer.
• The CD changer does not work at all.		Reset the unit. (☞ page 3)

	Symptoms	Remedies/Causes
iPod/D. player	<ul style="list-style-type: none"> <li>The iPod/D. player does not turn on or does not work.</li> </ul>	<ul style="list-style-type: none"> <li>Check the connecting cable and its connection.</li> <li>Charge the battery.</li> <li>For D. player: Update the firmware version.</li> </ul>
	<ul style="list-style-type: none"> <li>Sound is distorted.</li> </ul>	Deactivate the equalizer either on this unit or the iPod/D. player.
	<ul style="list-style-type: none"> <li>"Disconnect" appears on the monitor.</li> </ul>	Check the connecting cable and its connection.
	<ul style="list-style-type: none"> <li>For iPod: Playback stops.</li> </ul>	The headphones are disconnected during playback. Restart playback.
	<ul style="list-style-type: none"> <li>No sound can be heard.</li> <li>"Error 01" appears on the monitor when connecting a D. player.</li> </ul>	Disconnect the D. player from the adapter. Then, connect them again.
	<ul style="list-style-type: none"> <li>"No Files" or "No Track" appears on the monitor.</li> </ul>	No tracks are stored. Import tracks to the iPod or D. player.
	<ul style="list-style-type: none"> <li>"Reset 01" – "Reset 07" appears on the monitor.</li> </ul>	Disconnect the adapter from both this unit and iPod/D. player. Then, connect them again.
	<ul style="list-style-type: none"> <li>"Reset 08" appears on the monitor.</li> </ul>	Check the connection between the adapter and this unit.
	<ul style="list-style-type: none"> <li>The iPod's or D. player's controls do not work after disconnecting from this unit.</li> </ul>	Reset the iPod or D. player.
AV-IN	<ul style="list-style-type: none"> <li>No picture appears on the monitor.</li> </ul>	<ul style="list-style-type: none"> <li>Turn on the video component if it is not on.</li> <li>This unit is not connected to the video component correctly. Connect it correctly.</li> </ul>
	<ul style="list-style-type: none"> <li>Playback picture is not clear and legible.</li> </ul>	Adjust items in <Picture Adjust>. (☞ page 51)

# Specifications

AMPLIFIER	Maximum Power Output:	Front/Rear:	50 W per channel
	Continuous Power Output (RMS):	Front/Rear:	20 W per channel into 4 $\Omega$ , 40 Hz to 20 000 Hz at no more than 0.8% total harmonic distortion
	Load Impedance:		4 $\Omega$ (4 $\Omega$ to 8 $\Omega$ allowance)
	Equalizer Control Range:	Frequencies:	60 Hz, 150 Hz, 400 Hz, 1 kHz, 2.5 kHz, 6.3 kHz, 15 kHz
		Level:	$\pm 10$ dB
	Signal-to-Noise Ratio:		70 dB
	Audio Output Level	Line-Out Level/Impedance:	5.0 V/20 k $\Omega$ load (full scale)
	LINE OUT (FRONT/REAR)/ CENTER OUT/ SUBWOOFER:	Output Impedance:	1 k $\Omega$
	Color System:		NTSC/PAL
	Video Output (composite):		1 Vp-p/75 $\Omega$
	Other Terminals:	Input:	LINE IN, VIDEO IN, CAMERA IN, USB input terminal, Antenna input
		Output:	2nd AUDIO OUT, VIDEO OUT
Others:		CD changer	
FM/AM TUNER	Frequency Range:	FM:	87.5 MHz to 108.0 MHz
		AM:	531 kHz to 1 602 kHz
	FM Tuner	Usable Sensitivity:	11.3 dBf (1.0 $\mu$ V/75 $\Omega$ )
		50 dB Quieting Sensitivity:	16.3 dBf (1.8 $\mu$ V/75 $\Omega$ )
		Alternate Channel Selectivity (400 kHz):	65 dB
		Frequency Response:	40 Hz to 15 000 Hz
		Stereo Separation:	35 dB
AM Tuner	Sensitivity/Selectivity:	20 $\mu$ V/35 dB	
DVD/CD	Signal Detection System:	Non-contact optical pickup (semiconductor laser)	
	Frequency Response:	DVD, fs=48 kHz:	16 Hz to 22 000 Hz
		DVD, fs=192 kHz:	16 Hz to 88 000 Hz
		VCD/CD:	16 Hz to 20 000 Hz
	Dynamic Range:	93 dB	
	Signal-to-Noise Ratio:	95 dB	
Wow and Flutter:	Less than measurable limit		

SD	Compatible File System:	FAT 32/16/12		
	Capacity	8 Mbytes to 2 Gbytes		
	Data Transfer Rate	Maximum 10 Mbps		
USB	USB Standards:	USB 1.1		
	Data Transfer Rate	Full Speed: Maximum 12 Mbytes Low Speed: Maximum 1.5 Mbytes		
	Compatible Device:	Mass storage class		
	Compatible File System:	FAT 32/16/12		
	Max. Current:	Less than 500 mA/5V		
MONITOR	Screen Size:	7 inch wide liquid crystal display		
	Number of Pixel:	336 960 pixels: 480 x 3 (horizontal) × 234 (vertical)		
	Drive Method:	TFT (Thin Film Transistor) active matrix format		
	Color System:	NTSC/PAL		
	Aspect Ratio:	16:9 (wide)		
GENERAL	Power Requirement:	Operating Voltage:	DC 14.4 V (11 V to 16 V allowance)	
	Grounding System:	Negative ground		
	Allowable Storage Temperature:	-10°C to +60°C		
	Allowable Operating Temperature:	0°C to +40°C		
	Dimensions (W × H × D):	Installation Size (approx.):	178 mm × 100 mm × 160 mm	
		Panel Size (approx.):	171 mm × 97 mm × 21 mm	
	Mass (approx.):	2.7 kg (including trims and sleeve)		

### Required space for the monitor ejection

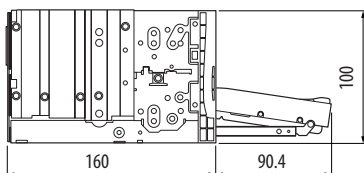

**CAUTION:** When ejecting the monitor, keep an open space for the monitor to come out. If not, the monitor may obstruct the steering wheel and gearshift lever operations, as this may result in a traffic accident.

Unit: mm

Terima kasih telah membeli produk JVC.

Harap membaca seluruh petunjuk dengan teliti sebelum mengoperasikan, untuk memastikan anda memahami secara keseluruhan dan mendapatkan performansi terbaik dari unit ini.

## PENTING UNTUK PRODUK-PRODUK LASER

1. PRODUK LASER KELAS 1
2. **PERHATIAN:** Jangan membuka penutup atas. Tidak ada bagian yang dapat diperbaiki oleh pengguna di dalam unit tersebut; biarkanlah semua bagian yang diperbaiki untuk memenuhi syarat perbaikan teknis.
3. **PERHATIAN:** Apabila terbuka, radiasi laser kelas 1M dapat terlihat dan/atau tidak terlihat. Jangan langsung melihatnya dengan alat optik.
4. REPRODUKSI DARI LABEL: LABEL PERHATIAN, TEMPATKAN DI LUAR UNIT TERSEBUT.

<b>CAUTION</b> VISIBLE AND/OR INVISIBLE CLASS 1M LASER RADIATION WHEN OPEN. DO NOT VIEW DIRECTLY WITH OPTICAL INSTRUMENTS. IEC06026-1:2001 (EN6)	<b>ATTENTION</b> RAYONNEMENT LASER VISIBLE ET/OU INVISIBLE DE CLASSE 1M LORS QU'EST OUVERT. NE PAS REGARDER DIRECTEMENT AVEC DES INSTRUMENTS OPTIQUES. (FRN)	<b>AVISO</b> RADIACION LASER DE CLASE 1M VISIBLE Y/O INVISIBLE CUANDO ESTA ABIERTO. NO MIRAR DIRECTAMENTE CON INSTRUMENTAL OPTICO. (ESP)	<b>VARNING</b> SYNLJG OCH/ELLER OBYNLJG LASERSTRÅLNING. KLASS 1M, NÅR DENNA DEL ÄR ÖPPNAD. BETRAKTA EJ STRÅLEN MED OPTISKA INSTRUMENT. (SWE)	<b>注意</b> ここを覆くと可能 及び/または不可視 のクラス1M レーザー放射が 出ます。 光学装置で直接 見ないでください。 (JPN)	<b>CAUTION</b> VISIBLE AND/OR INVISIBLE CLASS II LASER RADIATION WHEN OPEN. DO NOT STARE INTO BEAM. FDA 21 CFR (EN6) LV44603-003A
--	---	---	---	--	---

### PERHATIAN pada monitor:

- Monitor yang dipasang di dalam alat penerima ini dibuat dengan presisi tinggi, tetapi mungkin masih mengandung titik-titik yang tidak efektif. Hal ini tak dapat dihindarkan dan bukan kesalahan fungsi.
- Jangan biarkan monitor terkena sinar matahari langsung.
- Jangan mengoperasikan panel sentuh dengan menggunakan bolpen atau alat serupa yang berujung tajam.  
Sentuh tombol-tombol pada panel sentuh dengan jari Anda secara langsung (jika Anda memakai sarung tangan, lepaskan dulu).
- Ketika temperatur sangat dingin atau sangat panas...
  - Terjadi perubahan kimia di dalam, menyebabkan kesalahan fungsi.
  - Gambar-gambar mungkin tidak tampak bersih atau mungkin bergerak lambat. Gambar-gambar mungkin tidak sinkron dengan suara atau kualitas gambar mengalami kemunduran dalam beberapa lingkungan-lingkungan.



[Hanya Uni Eropa]

### PERINGATAN:

#### Untuk mencegah kecelakaan dan kerusakan

- JANGAN menginstal unit apa pun dan menjalin kabel apa pun pada lokasi di mana;
  - ini dapat menghalangi pengoperasian roda kemudi dan tuas gigi persneling.
  - ini dapat menghalangi pengoperasian alat pengaman seperti kantong udara.
  - mungkin menghalangi pandangan.
- JANGAN mengoperasikan unit sewaktu mengemudi.  
Jika Anda harus mengoperasikan unit sewaktu mengemudi, pastikan Anda melihat ke sekeliling dengan hati-hati.
- Pengemudi tidak boleh menonton monitor selagi mengemudi.
- Pengemudi tidak boleh menggunakan headphone selagi mengemudi.

## ■ Bagaimana mereset unit anda

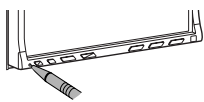

- Penyetelan-penyetelan pengaturan awal anda akan terhapus juga.

## ■ Bagaimana secara paksa mengeluarkan sebuah disk

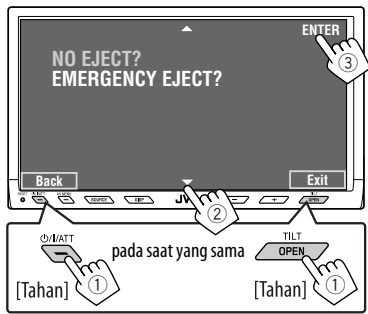

- Jika ini tidak berhasil, setel ulang alatnya.

### Untuk keselamatan...

- Jangan menaikkan level volume terlalu tinggi karena akan menghalangi suara dari luar, dan membahayakan perjalanan anda.
- Hentikan mobil sebelum melakukan pengoperasian yang rumit.

### Suhu dalam mobil...

Jika anda telah memarkir mobil terlalu lama dalam cuaca yang panas atau dingin, tunggu hingga suhu dalam mobil menjadi normal kembali sebelum mengoperasikan unit ini.

# Daftar isi

## PENDAHULUAN

Jenis disk yang dapat diputar ..... 4

Pengoperasian dasar—  
Panel monitor/panel sentuh ..... 5

Pengoperasian dasar—  
Remote kontrol (RM-RK251)..... 6

## PENGOPERASIAN

Sebelum mengoperasikan unit..... 8

Pengoperasian umum..... 9

Mendengarkan radio ..... 10

Pengoperasian disk ..... 13

Pengoperasian-pengoperasian  
Dual Zone (Zona Dual) ..... 27

Pengoperasian SD..... 30

Pengoperasian USB ..... 32

## ALAT EKSTERNAL

Pengoperasian Bluetooth®—  
Ponsel/pemutar audio ..... 34

Mendengarkan CD changer..... 41

Mendengarkan iPod/D. player ..... 43

Menggunakan komponen eksternal  
lainnya ..... 45

## PENGATURAN

Penyeragaman suara ..... 48

Menetapkan judul untuk sumber..... 49

Pengoperasian menu ..... 50

## REFERENSI

Perawatan ..... 60

Lebih lagi tentang alat penerima ini ... 61

Pemecahan masalah..... 67

Spesifikasi-spesifikasi ..... 72

## Jenis disk yang dapat diputar

Tipe disk	Format perekaman, jenis file, dsb.	Dapat diputar
<b>DVD</b>	DVD Video (Kode Wilayah: 3)* <sup>1</sup> 	✓ <b>OK</b>
	DVD-Audio	
	DVD-ROM	✗ <b>NO</b>
<b>DVD Recordable/Rewritable (DVD-R*<sup>2</sup>/-RW, +R/+RW*<sup>3</sup>)</b> <ul style="list-style-type: none"> <li>DVD Video: UDF bridge</li> <li>DVD-VR</li> <li>DivX/MPEG1/MPEG2/JPEG/MP3/WMA/WAV/AAC: ISO 9660 level 1, level 2, Romeo, Joliet</li> <li>DVD-RAM tidak bisa diputar.</li> </ul>	DVD Video	✓ <b>OK</b>
	DVD-VR (hanya non-CPRM)	
	DivX/MPEG1/MPEG2	
	JPEG	
	MP3/WMA/WAV/AAC* <sup>4</sup>	✗ <b>NO</b>
	MPEG4	
DVD+VR		
<b>Dual Disc</b>	Bagian DVD	✓ <b>OK</b>
	Bagian non-DVD	✗ <b>NO</b>
<b>CD/VCD</b>	CD Audio/Teks CD (CD-DA)/DTS-CD	✓ <b>OK</b>
	VCD (Video CD)	✓ <b>OK</b>
	CD-ROM	
	CD-I (CD-I Ready)	✗ <b>NO</b>
<b>CD Recordable/Rewritable (CD-R/-RW)</b> <ul style="list-style-type: none"> <li>ISO 9660 level 1, level 2, Romeo, Joliet</li> </ul>	CD-DA	✓ <b>OK</b>
	MP3/WMA/WAV/AAC* <sup>4</sup>	
	JPEG	
	DivX/MPEG1/MPEG2	
	MPEG4	✗ <b>NO</b>

\*<sup>1</sup> Jika anda menyisipkan sebuah disk DVD Video yang tidak benar Kode Regionnya, "Region code error" muncul pada monitor.

\*<sup>2</sup> DVD-R yang direkam dalam format multi-border, juga dapat diputar (kecuali disk lapis ganda).

\*<sup>3</sup> Anda dapat memutar kembali disk +R/+RW (hanya format video) yang sudah dirampungkan. Namun, penggunaan disk lapis ganda +R tidak direkomendasikan.

\*<sup>4</sup> Unit ini dapat memutar kembali file AAC yang disandi menggunakan iTunes.

### Perhatian untuk putar ulang DualDisc

Sisi yang non-DVD dari sebuah "DualDisc", tidak tunduk pada standar "Compact Disc Digital Audio". Oleh karena itu, penggunaan sisi Non-DVD dari sebuah DualDisc pada produk ini tidak disarankan.

# Pengoperasian dasar — Panel monitor/panel sentuh

## Tampilkan <AV Menu>.

- halaman 50.

## Tampilkan <Source Menu>.

- halaman 9 dan 27.

### Menampilkan dan menghapus jendela Short Cut [Jalan Pintas].

Fungsi yang tersedia dapat beragam di antara berbagai sumber. Untuk rinciannya, lihat setiap bagian operasi sumber.

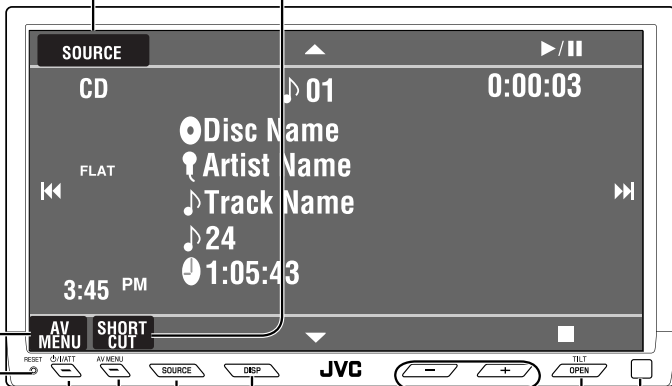

- Menghidupkan power.
  - Matikan daya [Tahan].
  - Melemahkan suara (jika daya (power) dalam posisi on).
- Reset alat penerima.**
- Hanya gunakan apabila sistem internal tidak berfungsi dengan baik.
- Mengubah sumber.**
- halaman 9.
- Tampilkan <AV Menu>.**
- halaman 50.
- Mengganti tampilan informasi.**
- Menampilkan layar <Open/Tilt>
  - Mengeluarkan disc dan menampilkan layar <Open/Tilt> [Tahan].
  - Menutup panel monitor saat layar <Open/Tilt> ditampilkan.
- Setel volume.**
- Sensor remote kontrol**

Inset image showing the 'Open/Tilt' menu options: OPEN, EJECT, CLOSE, TILT+, and TILT-.

- [OPEN]: Bukan panel monitor.
- [EJECT]: Mengeluarkan disk.
- [CLOSE]: Tutup panel monitor.
- [TILT +/-]: Ungkit panel monitor.
- [Exit]: Hapus pesan ini.
- Ikon yang diburamkan tidak dapat digunakan saat itu.

• Untuk rincian tentang pengoperasian panel sentuh, lihat setiap bagian operasi sumber.

# Pengoperasian dasar — Remote kontrol (RM-RK251)

## Memasang baterai

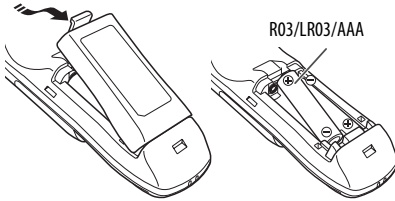

Jika jangkauan atau efektivitas remote control menurun, gantilah kedua baterainya.

## Sebelum menggunakan Remote kontrol:

- Arahkan remote control secara langsung ke sensor remote control pada unit.
- JANGAN memaparkan sensor remote control ke cahaya yang sangat terang (cahaya matahari langsung atau pencahayaan artifisial).

### Perhatian:

- Jangan memaparkan baterai ke panas atau nyala api.

### PENTING:

Jika Dual Zone (Zona Dual) diaktifkan (☞ halaman 27), remote control hanya berfungsi untuk mengoperasikan DVD/CD player.

## Elemen-elemen utama dan fitur-fitur

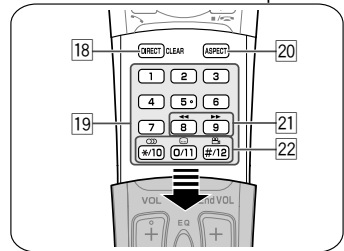
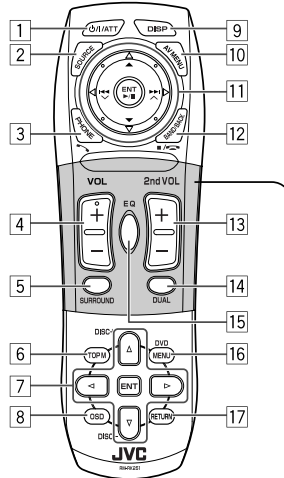

- <sup>\*1</sup> • Menghidupkan daya.  
• Melemahkan suara jika daya (power) dalam posisi on.  
• Mematikan daya (power) jika ditekan terus (sewaktu power menyala).
- <sup>\*1</sup> Memilih sumber.
- <sup>\*1</sup> • Menampilkan <Dial Menu>.  
• Menampilkan daftar <Redial> jika ditekan terus.  
• Menjawab panggilan masuk.
- <sup>\*1,2</sup> Menyetel level volume.

- 5\*<sup>1,2</sup> Memilih modus surround.
- 6
- DVD/DivX 6: Tunjukkan menu disk.
  - VCD: Memulai pemutaran PBC.
  - DVD-VR: Menunjukkan layar Original Program [Program Asli].
- 7
- Melakukan pemilihan/pengaturan.
  - <B>: Lompat atau majukan 5 menit untuk DivX/MPEG1/MPEG2.
  - Tombol DISC +/-: Ganti disk ke "CD-CH".
- 8 Menunjukkan bar pada-layar.
- 9\*<sup>1</sup> Mengubah informasi tampilan.
- 10 Menampilkan atau menghapus <AV Menu>.
- 11 **Untuk pengoperasian disc/SD/USB:**

- ►/II: Putar/jeda.
- ▲ / ▼:
  - DVD: Memilih judul/grup.
  - DVD-VR: Memilih program/daftar putar.
  - SD/USB/disc lainnya (kecuali VCD/CD): Memilih folder-folder.
- I◀◀ / ▶▶I:
  - Tekan dengan singkat: melompat mundur/melompat maju.
  - Tekan dan tahan: pencarian mundur/pencarian maju.

#### Untuk operasi FM/AM:

- ▲ / ▼: Memilih stasiun prasetel.
- I◀◀ / ▶▶I: Berfungsi untuk mencari stasiun-stasiun.
  - Tekan dengan singkat: Auto Search [Pencarian Otomatis]
  - Tekan dan tahan: Manual Search [Pencarian Manual]

#### Untuk pengoperasian Apple iPod/JVC D. player:

- ▼: Menunda/menghentikan atau melanjutkan pemutaran.
- ▲: Masuk ke menu utama (selanjutnya, ▲ / ▼ / I◀◀ / ▶▶I berfungsi sebagai tombol pemilihan menu).<sup>\*3</sup>
- I◀◀ / ▶▶I (dalam mode pemilihan menu)
  - Memilih item jika ditekan sekilas. (Kemudian, tekan ▼ untuk mengkonfirmasi pilihan.)
  - Meloncati 10 item sekaligus jika ditekan terus.

#### Untuk operasi Bluetooth:

- I◀◀ / ▶▶I: lompat mundur/lompat maju (untuk operasi audio)
- ►/II: Menjawab panggilan masuk (untuk "Bluetooth PHONE"), putar/jeda (untuk "Bluetooth AUDIO").

- 12 TUNER: Memilih jalur.  
DISC/SD/USB: Hentikan pemutaran.  
Bluetooth PHONE: Mengakhiri panggilan.  
Bluetooth AUDIO: Putar/jeda.
- Tombol ini tidak berfungsi sebagai tombol BACK [KEMBALI] untuk model ini.
- 13\*<sup>2</sup> Menyesuaikan volume melalui steker 2nd AUDIO OUT.
- 14\*<sup>2</sup> Mengaktifkan atau menonaktifkan Dual Zone (Zona Dual).
- 15\*<sup>1,2</sup> Memilih mode suara.
- 16
- DVD Video/DivX 6: Tunjukkan menu disk.
  - VCD: Memulai pemutaran PBC.
  - DVD-VR: Menunjukkan layar Play List [Daft. Putar].
- 17 Tombol RETURN
- Untuk VCD: Kembali ke menu PBC.
- 18 DISC/SD/USB: Menukar modus entri nomor.
- Juga berfungsi sebagai tombol CLEAR [HAPUS] untuk menghapus entri keliru setelah memasukkan nomor yang salah.
- 19
- Memasukkan nomor.
  - FM/AM: Memilih stasiun prasetel secara langsung.
  - CD changer: Memilih disc secara langsung.
- 20\*<sup>1</sup> Mengubah rasio aspek gambar pemutaran ulang.
- 21 Pencarian mundur/maju untuk pengoperasian disc/SD/USB.
- 22
- DVD Video: Memilih bahasa audio (○○○), subtitle (□□□), sudut (□□□).
  - DVD Audio: Memilih pengaliran audio (○○○).
  - DVD-VR: Aktifkan/Nonaktifkan teks (□□□), dan memilih saluran audio (○○○)
  - DivX: Memilih bahasa audio (○○○), subtitle (□□□).
  - VCD: Memilih saluran audio (○○○).

\*1 Jika Dual Zone (Zona Dual) diaktifkan, tombol-tombol ini tidak dapat digunakan.

\*2 Tombol-tombol ini hanya dapat digunakan jika penutup geseran ditutup.

\*3 ▲: Kembali ke menu sebelumnya.

▼: Mengkonfirmasi pemilihan.

# Sebelum mengoperasikan unit

Membatalkan demo tampilan dan menyetel jam waktu (lihat hal. 51 dan 52 untuk rinciannya).

- Item yang tidak tersedia akan ditampilkan buram pada layar AV Menu.

## Bahasa petunjuk:

Dalam buku panduan ini, petunjuk dalam bahasa Inggris digunakan untuk memberikan penjelasan. Anda dapat memilih bahasa petunjuk pada monitor. (lihat halaman 52)

### 1 Menghidupkan power.

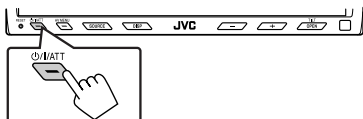

### 2 Tampilkan <AV Menu>.



### 3 Menampilkan menu <Setup>.

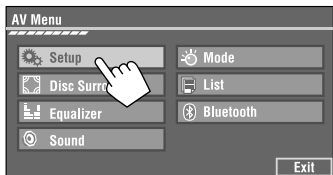

### 4 Batalkan demo tampilan.

Pilih <Off>.

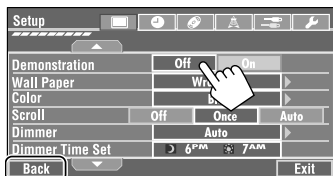

Kembali ke layar sebelumnya.

### 5 Menetapkan pengaturan jam.

Bergerak ke halaman menu sebelumnya

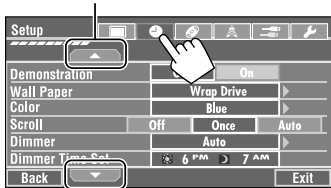

Bergerak ke halaman menu berikutnya

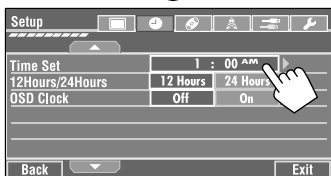

### 6 Prosedur selesai.

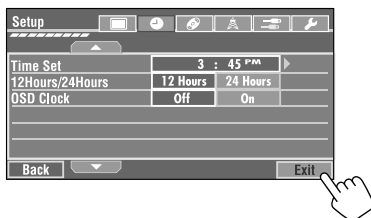

# Pengoperasian umum

## Memilih sumber playback [pemutaran]

- Sumber yang tersedia tergantung pada komponen eksternal yang dihubungkan, media yang dipasang dan pengaturan <Masukan> yang sudah Anda buat (☞ halaman 55 dan 56).

### Pada panel sentuh:

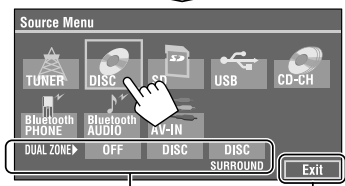

☞ halaman 27

Keluar

### Pada panel monitor:

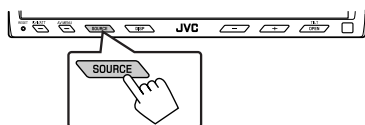

**TUNER → DISC (DVD/VCD/CD) → SD → USB → CD-CH, iPod, D.PLAYER, atau EXT-IN → Bluetooth PHONE → Bluetooth AUDIO → AV-IN →** (kembali ke permulaan)

- Anda tidak dapat memilih sumber ini jika sumber tersebut tidak siap.

## Mengganti tampilan informasi

- Informasi tampilan yang tersedia beragam di antara berbagai sumber pemutaran.

### Hanya pada panel monitor:

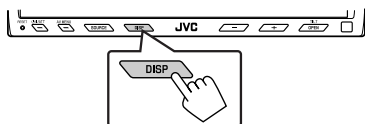

- Setiap kali menekan DISP, tampilan berubah untuk menunjukkan berbagai informasi.

Contoh: Apabila sumber pemutaran yaitu disc DivX.

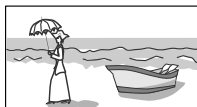

Layar pemutaran gambar (hanya untuk sumber video)



Layar informasi sumber



Daftar stasiun prasetel (layanan), daftar trek (file) atau daftar nomor telepon.

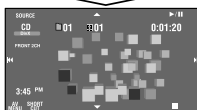

Layar animasi



Layar navigasi (Bila <Navigation> dipilih untuk <AV Input>): (☞ halaman 55).

Kembali ke permulaan

# Mendengarkan radio

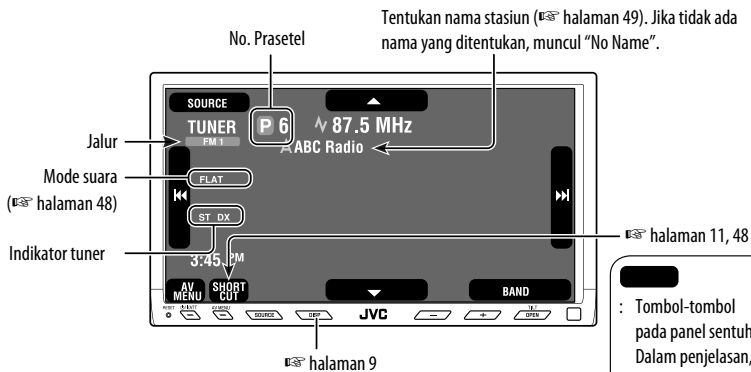

- 1 Tekan [SOURCE], lalu tekan [TUNER]. (halaman 9)
  - Anda juga dapat menggunakan SOURCE pada panel monitor. Tekan berulang kali.
- 2 Tekan [BAND]. → FM1 → FM2 → FM3 → AM
- 3 Tekan [◀◀] atau [▶▶] untuk mencari stasiun—Auto Search [Cari Otomatis].
  - Manual Search [Cari Manual]: Tahan [◀◀] atau [▶▶] sampai muncul "Manual Search" [Cari Manual] di layar, kemudian tekan berulang-ulang.
  - Indikator ST menyala ketika menerima sebuah siaran stereo FM dengan kekuatan sinyal yang cukup.

## Ketika sebuah siaran stereo FM sulit diterima

### 1 Tekan [AV MENU].



- Anda juga dapat menggunakan AV MENU pada panel monitor.

### 2 Tekan [Mode].

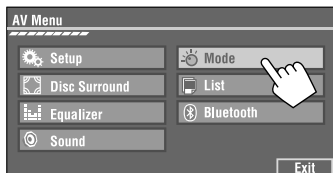

### 3

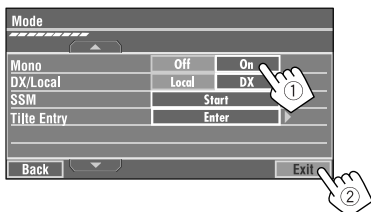

- Penerimaan membaik, tetapi efek stereo akan hilang.
- Lampu indikator MONO menyala.

Untuk memulihkan efek stereo, pilih <Off>.

## Menala stasiun yang sinyalnya cukup kuat

Fungsi ini hanya untuk jalur FM. Setelah Anda mengaktifkan fungsi ini (pilih <Local>), fungsi ini selalu menjadi aktif apabila mencari stasiun FM.

### 1 Tekan [AV MENU].



- Anda juga dapat menggunakan AV MENU pada panel monitor.

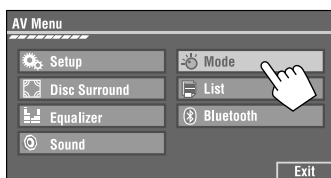

### 2 Tekan [Mode].

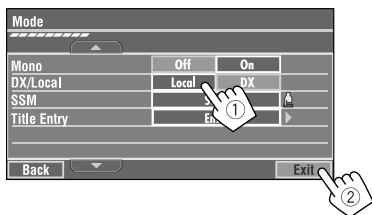

### 3



Hanya stasiun-stasiun dengan kekuatan sinyal yang cukup, yang akan terdeteksi.

- Indikator DX menghilang kemudian indikator LO menyala.
- Anda juga dapat mengubah pengaturan <IF Band Width> (lihat rinciannya di,  halaman 55). Menu <IF Band Width> dapat diakses dengan menekan [SHORT CUT] pada panel sentuh, lalu...  halaman 48

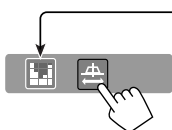

## Mempreset (Mengatur awal) secara otomatis stasiun FM—SSM (Memori Urutan Stasiun-Kuat)

Fungsi ini hanya untuk jalur FM.

Anda dapat preset (mengatur awal) enam stasiun untuk setiap jalur.

### 1 Tekan [AV MENU].



- Anda juga dapat menggunakan AV MENU pada panel monitor.

### 2 Tekan [Mode].

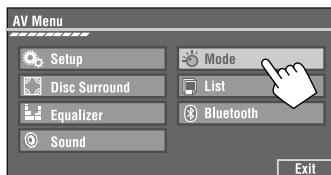

### 3

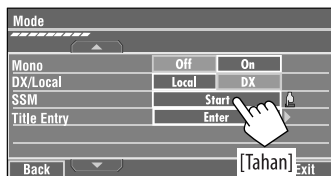

Stasiun-stasiun FM lokal dengan sinyal-sinyal terkuat dicari dan disimpan secara otomatis dalam jalur FM tersebut.

## Mempreset (Mengatur awal) secara manual

Contoh: Menyimpan stasiun FM dari 92.5 MHz ke dalam nomor prasetel 4 dari jarur FM1.

### 1 Tampilkan Preset List [Daftar Prasetel].

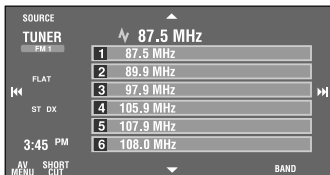
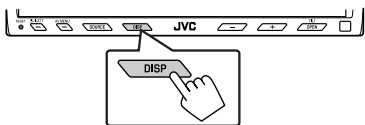

### 2 Menala ke stasiun yang ingin Anda setel sebelumnya.

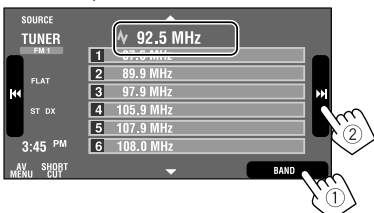

### 3 Pilih nomor yang telah diatur sebelumnya.

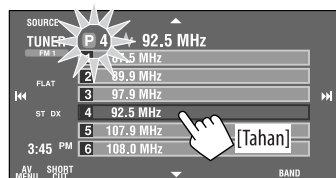

Stasiun yang dipilih dalam langkah 2 sekarang disimpan dalam nomor prasetel 4.

## Memilih stasiun preset

Pada pengontrol jauh:

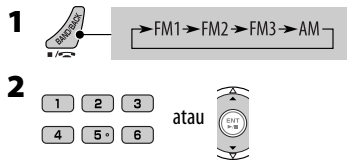

Pada unit:

Untuk langsung memilih pada panel sentuh

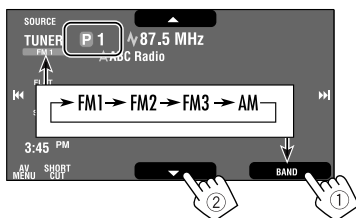

Untuk memilih dari Daftar Prasetel

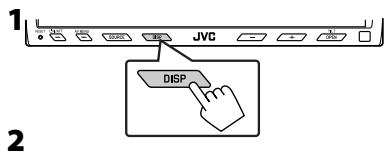

2



# Pengoperasian disk

Tipe disk secara otomatis terdeteksi dan mulai memutar ulang secara otomatis (untuk beberapa disk: mulai secara otomatis tergantung program di dalamnya).

Jika disk tidak memiliki menu disk apa pun, semua trek akan diputar berulang-ulang sampai Anda mengubah sumber atau mengeluarkan disk.

Jika “” muncul pada monitor, berarti radio tersebut tidak dapat menerima pengoperasian yang anda coba lakukan.

- Dalam beberapa kasus, tanpa mempertunjukkan “” pengoperasian tidak akan diterima.

## 1 Bukan panel monitor.

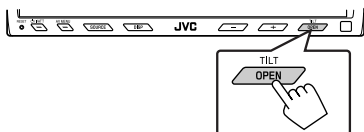

Menu <Open/Tilt> muncul.

- Ikon yang diburamkan tidak dapat digunakan saat itu.
- Dengan menekan terus tombol, Anda dapat membuka panel monitor dan mengeluarkan disk.

## 2 Tekan [OPEN].

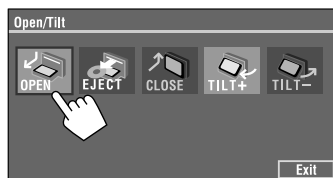

### Perhatian pada pengaturan volume:

Disk-disk menghasilkan sangat kecil noise (derau) dibandingkan dengan sumber yang lain. Kecilkan volume sebelum disk untuk menghindari kerusakan speaker-speaker dengan penambahan mendadak dari level (tingkat) keluaran.

## 3 Masukkan disc.

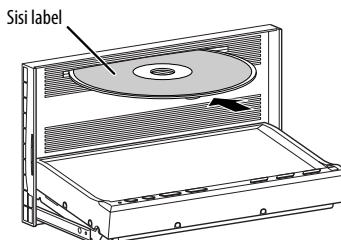

Panel monitor menutup secara otomatis. Jika tidak, tekan [CLOSE].

### Perhatian:

Jangan menaruh jari Anda di belakang panel monitor.

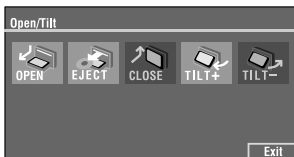

- [OPEN]: Buka panel monitor.
- [EJECT]: Mengeluarkan disk.
- [CLOSE]: Tutup panel monitor.
- [TILT +/-]: Ungkit panel monitor.
- [Exit]: Hapus pesan ini.

Sewaktu memutar disk berikut, tekan **DISP**.

- Setiap kali menekan tombol, tampilan berubah untuk menunjukkan informasi yang berbeda (☞ halaman 9).



DVD Video: No. judul/No. Chapter/Waktu Putar  
 DVD-VR: No. program (atau no. Daftar Putar)/No. Chapter/Waktu putar

- Tipe disk \*1
- Format audio
- Mode putar ulang
- Indikator-indikator speaker/sinyal (☞ halaman 61)

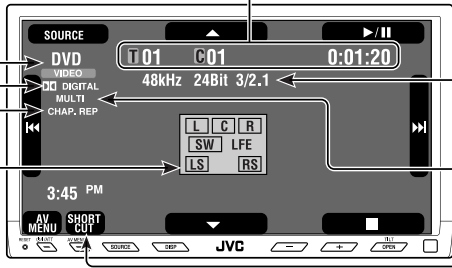

- Sampling frequency/ Bit rate/No. saluran sinyal rekaman
- Modus Surround (☞ halaman 24)

☞ halaman 19

☐ : Tombol-tombol pada panel sentuh. Dalam penjelasan, semuanya ditunjukkan di dalam [ ]. Tombol-tombol ini juga berfungsi jika tidak ditunjukkan pada panel sentuh (sewaktu menonton film di layar).

- [▶ / ||] Memulai dan menunda pemutaran
- [■] Menghentikan pemutaran
- [◀◀▶▶▶] Tekan: Pilih chapter
- [▲▼] Tahan: Pencarian mundur/maju\*2
- [▲▼] Pilih judul/program/daf. putar



No. Grup/No. Trek/Waktu putar

- Indikator BONUS (☞ halaman 23)

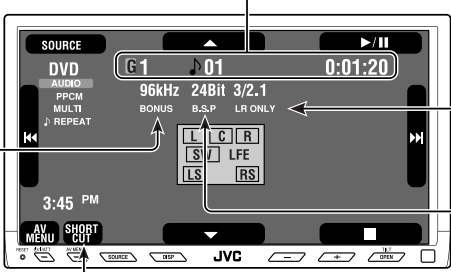

- Indikator suara reproduksi— MULTI CH/LR ONLY (☞ halaman 62)
- Indikator B.S.P (☞ halaman 23)

☞ halaman 19

- [▶ / ||] Memulai dan menunda pemutaran
- [■] Menghentikan pemutaran
- [◀◀▶▶▶] Tekan: Pilih trek
- [▲▼] Tahan: Pencarian mundur/maju\*2
- [▲▼] Pilih grup

\*1 DVD-VR juga menunjukkan pemutaran PRG (program) atai PLAY (daf. putar).

\*2 Kecepatan cari: x2 ⇔ x10.

Sewaktu memutar disk berikut, tekan **DISP**.

- Setiap kali menekan tombol, tampilan berubah untuk menunjukkan informasi yang berbeda (☞ halaman 9).



Untuk DivX/MPEG1/MPEG2: No. Folder/No. trek/Waktu putar  
Untuk JPEG: No. Folder/No. Trek

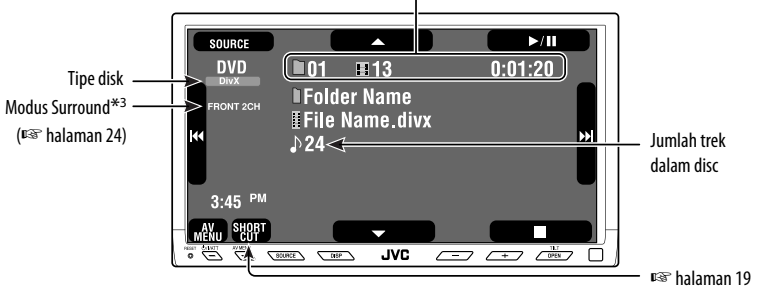

Tipe disk  
Modus Surround\*3  
(☞ halaman 24)

Jumlah trek dalam disc

☞ halaman 19

- [▶ / ||] Memulai dan menunda pemutaran
- [■] Menghentikan pemutaran
- [◀◀▶▶▶▶] Tekan: Pilih trek  
Tahan: Pencarian mundur/maju untuk DivX/MPEG1/MPEG2 \*4
- [▲ ▼] Tekan: Pilih folder  
Tahan: Tampilkan Folder List [Daftar Folder]



No. trek/Waktu putar

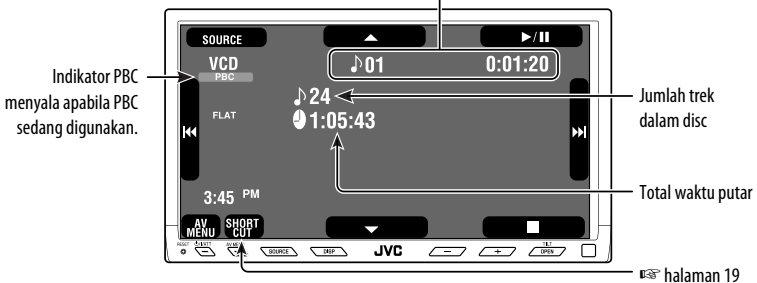

Indikator PBC menyala apabila PBC sedang digunakan.

Jumlah trek dalam disc

Total waktu putar

☞ halaman 19

- [▶ / ||] Memulai dan menunda pemutaran
- [■] Menghentikan pemutaran
- [◀◀▶▶▶▶] Tekan: Pilih trek  
Tahan: Pencarian mundur/maju\*2

\*2 Kecepatan cari: x2 ⇔ x10.

\*3 Modus surround dan modus suara tidak dapat digunakan bersamaan.

\*4 Kecepatan cari: ▶▶ 1 ⇔ ▶▶▶ 2.



## Tombol pengoperasian pada layar monitor

Anda dapat menampilkan tombol pengoperasian berikut sewaktu menonton pemutaran film pada monitor.

- Sewaktu tombol pengoperasian ditampilkan, rasio aspek ditetapkan ke <Full> (☞ halaman 52).
- Jika tidak ada pengoperasian selama sekitar 5 detik, tombol pengoperasian menghilang (kecuali jika menu disc ditampilkan).

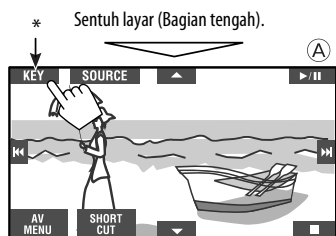
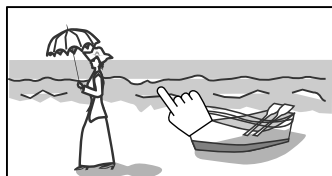

Sentuh [KEY].

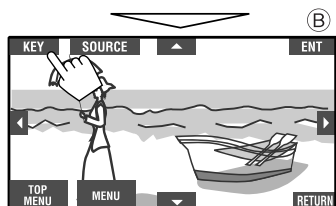

Sentuh [KEY].

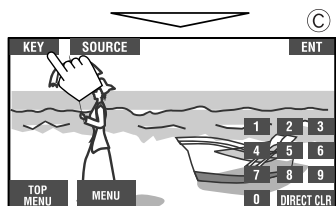

Sentuh [KEY].

☞ halaman 20 sampai 22 tentang cara kerja tombol pengoperasian untuk berbagai disc

**Untuk menghapus pengoperasian, sentuh lagi layar.**

- (A)
- [SOURCE] Menampilkan <Source Menu>
  - [AV MENU] Menampilkan <AV Menu>
  - [SHORT CUT] Menampilkan tombol Short Cut (Jalan Pintas)
  - [▶ / II] Memulai dan menunda pemutaran
  - [■] Menghentikan pemutaran
  - [◀◀▶▶] Tekan: Pilih trek  
Tahan: Pencarian mundur/maju
  - [▲ ▼] Memilih folder-folder

• Tombol-tombol di atas ini juga berfungsi jika tidak ditunjukkan pada panel sentuh (sewaktu menonton film di layar).

\* Sewaktu menu disc diputar kembali untuk DVD, [KEY] secara otomatis ditampilkan. Pada menu disc, Anda dapat memilih item menu secara langsung dengan menyentuhnya di layar.

(B)

Untuk pemutaran operasi menu DVD/VCD/DivX

- [◀▶▲▼] Memilih item menu
- [ENT] Mengkonfirmasi pemilihan
- [TOP MENU] Menampilkan menu disc
- [MENU] Menampilkan menu disc
- [RETURN] Kembali ke menu sebelumnya atau menampilkan menu (hanya untuk VCD dengan PBC)

(C)

Untuk memasukkan nomor

- [DIRECT CLR] Beralih antara entri bab/trek dan entri judul/grup/folder  
Menghapus entri terakhir jika Anda memasukkan nomor yang salah
  - [0]–[9]→[ENT] Masukkan angkanya
- Contoh: Untuk memasukkan "105": tekan [1], [0], [5] kemudian [ENT]

## Memilih mode-mode putar ulang

Anda dapat menggunakan hanya satu dari mode putar ulang berikut—Intro/Repeat/Random.

Contoh: Untuk memilih Track Repeat [Ulang Trek]



- Anda juga dapat menggunakan AV MENU pada panel monitor.

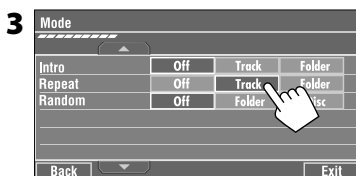
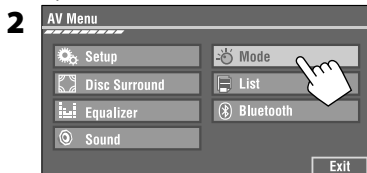

Apabila salah satu modus pemutaran dipilih, lampu indikator yang terkait menyala pada layar informasi sumber.

Untuk membatalkan, pilih <Off>.

Type disk	Intro	Repeat	Random
	—	<b>Chapter:</b> Mengulangi chapter yang sekarang diputar <b>Title:</b> Mengulangi title [judul] yang sekarang diputar	—
	—	<b>Track:</b> Mengulangi trek yang sekarang diputar	—
	—	<b>Chapter:</b> Mengulangi chapter yang sekarang diputar <b>Program:</b> Mengulang program yang sekarang (tidak tersedia untuk pemutaran Playlist).	—
 	<b>Track:</b> Memutar 15 detik pertama dari setiap trek (untuk VCD: PBC tidak digunakan)	<b>Track:</b> Mengulangi trek yang sekarang diputar* <sup>1</sup> (untuk VCD: PBC tidak digunakan)	<b>Disc (All):</b> Memutar secara acak semua trek (untuk VCD: PBC tidak digunakan)
	<b>Track:</b> Memutar 15 detik pertama dari setiap trek <b>Folder:</b> Memutar 15 detik pertama dari trek pertama setiap folder	<b>Track:</b> Mengulangi trek yang sekarang diputar* <sup>1</sup> <b>Folder:</b> Mengulang semua trek dari folder yang sekarang diputar	<b>Folder:</b> Memutar secara acak semua trek dari folder yang sekarang diputar, kemudian trek dari folder berikutnya <b>Disc (All):</b> Memutar secara acak semua trek
 	—	<b>Track:</b> Mengulangi trek yang sekarang diputar <b>Folder:</b> Mengulangi folder yang sekarang diputar	—
	—	<b>Folder:</b> Mengulangi folder yang sekarang diputar	—

\*<sup>1</sup> Anda juga dapat menggunakan [SHORT CUT] untuk mengaktifkan/nonaktifkan Pengulangan Trek

## Memilih trek dalam daftar

Jika disc menyertakan folder, Anda dapat menampilkan Daftar Folder/Trek (File), lalu memulai pemutaran.



- Anda juga dapat menggunakan AV MENU pada panel monitor.

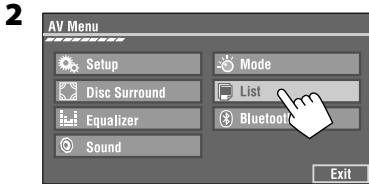

### 3 Pilih folder (1), lalu trek (2).

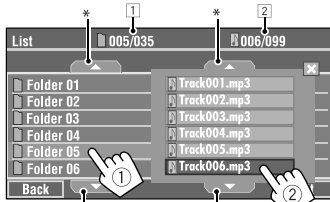

Trek yang dipilih mulai diputar. (\* Tekan untuk bergerak ke halaman sebelumnya/berikutnya dari daftar)

- 1 Nomor daftar folder yang sekarang/total daftar folder
- 2 Nomor daftar trek yang sekarang/total daftar trek dari folder yang sekarang

- Daftar Trek juga dapat diakses dengan menekan DISP pada panel monitor.

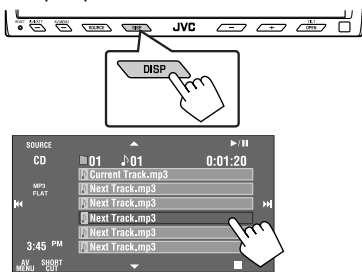

Trek yang dipilih mulai diputar.

## Mencegah pengeluaran disk

Anda dapat mengunci sebuah disk dalam celah pemutaran.

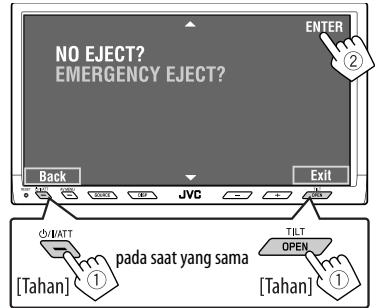

Untuk membatalkan larangan, ulangi prosedur yang sama untuk memilih <EJECT OK>.

## Menggunakan Ikon Short Cut

Anda dapat dengan mudah mengakses sejumlah fungsi yang sering dipakai dengan menggunakan [SHORT CUT] pada panel sentuh.



- Anda juga dapat menggunakan AV MENU pada panel monitor.

- 2 Untuk perangkat lunak video:

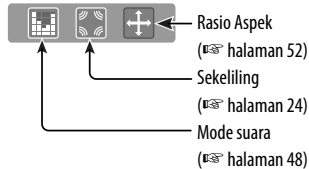

- Untuk perangkat lunak audio:



# Pengoperasian dengan menggunakan remote control—RM-RK251

INDONESIA

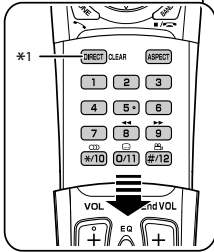
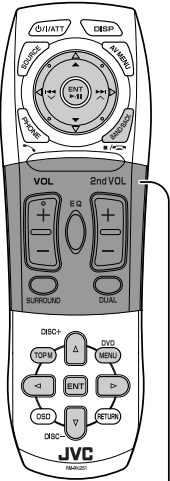

- \*1 Menghapus entri nomor yang keliru.
- \*2 Kecepatan cari:  $x2 \Rightarrow x5 \Rightarrow x10 \Rightarrow x20 \Rightarrow x60$
- \*3 Kecepatan gerakan lambat:  $1/32 \Rightarrow 1/16 \Rightarrow 1/8 \Rightarrow 1/4 \Rightarrow 1/2$
- \*4 Kecepatan cari:  $x2 \Rightarrow x10$
- \*5 Kecepatan cari:  $\blacktriangleright\blacktriangleright 1 \Rightarrow \blacktriangleright\blacktriangleright 2 \Rightarrow \blacktriangleright\blacktriangleright 3$
- \*6 Kecepatan cari:  $\blacktriangleright\blacktriangleright 1 \Rightarrow \blacktriangleright\blacktriangleright 2$



- : Hentikan pemutaran.
- : Mulai putar/jeda (jika ditekan sewaktu pemutaran).
- : Pencarian mundur/maju\*<sup>2</sup>. (Tidak ada suara yang terdengar). (Gerakan lambat\*<sup>3</sup> sewaktu jeda. Tidak ada suara yang terdengar.)
- : Tekan: Memilih chapter (sewaktu pemutaran atau jeda). Tahan: Pencarian mundur/maju\*<sup>4</sup>.
- : Pilih judul (sewaktu pemutaran atau jeda).

$\rightarrow$  ...  $\rightarrow$  :

Pilih chapter.  
Memilih judul (ketika tidak memutar).

(dua kali)  $\rightarrow$  ...  $\rightarrow$  :

Pilih judul (sewaktu pemutaran atau jeda).

- : Pilih rasio aspek.
- : Pilih bahasa audio.
- : Pilih bahasa subtitle.
- : Pilih sudut tampilan.

### Menggunakan fitur arahan menu

- 1 Pilih item yang ingin Anda putar.
- 2 Pilih item yang ingin Anda putar.
- 3



- : Hentikan pemutaran.
- : Mulai putar/jeda (jika ditekan sewaktu pemutaran).
- : Pencarian mundur/maju\*<sup>2</sup>.
- : Tekan: Memilih trek. Tahan: Pencarian mundur/maju\*<sup>4</sup>.
- : Pilih grup.

$\rightarrow$  ...  $\rightarrow$  :

Pilih trek.

(dua kali)  $\rightarrow$  ...  $\rightarrow$  :

Memilih grup (sewaktu pemutaran atau jeda).

- : Pilih rasio aspek.
- : Memilih pengaliran audio.

### Menggunakan fitur arahan menu

- 1 Pilih item yang ingin Anda putar.
- 2 Pilih item yang ingin Anda putar.
- 3



Hentikan pemutaran.



Mulai putar/jeda (jika ditekan sewaktu pemutaran).



Pencarian mundur/maju\*5. (Tidak ada suara yang terdengar).



Tekan: Memilih trek.

Tahan: Pencarian mundur/maju\*6. (Tidak ada suara yang terdengar).



Pilih folder.



Pilih trek (dalam folder yang sama).

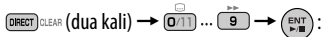

Pilih folder.

ASPECT : Pilih rasio aspek.

CD / #/10 : Pilih bahasa audio. (Hanya DivX)

0/11 : Pilih bahasa subtitle. (Hanya DivX)

**Sewaktu memutar...**

Kembali/majukan scene 5 menit.

**Untuk DivX6: Menggunakan fitur arahan menu**



2 Pilih item yang ingin Anda putar.

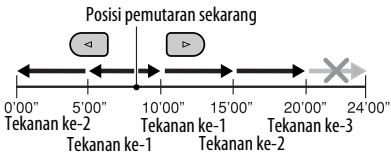

Hentikan pemutaran.



Mulai putar/jeda (jika ditekan sewaktu pemutaran).



Pencarian mundur/maju\*2. (Tidak ada suara yang terdengar).  
(Gerakan lambat\*3 sewaktu jeda. Tidak ada suara yang terdengar.)

• Gerakan lambat mundur tidak bekerja.



Tekan: Memilih chapter (sewaktu pemutaran atau jeda).

Tahan: Pencarian mundur/maju\*4.



Memilih program.  
Memilih daftar putar (sewaktu pemutaran atau jeda).

ASPECT :

Pilih rasio aspek.

CD / #/10 :

Pilih saluran audio (ST: stereo, L: Kiri, R: Kanan).

0/11 : Aktifkan/nonaktifkan teks.



Pilih chapter.

Memilih program (ketika tidak memutar).

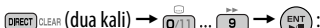

Memilih program/daftar putar (sewaktu memutar atau jeda).

**Menggunakan layar Program Asli/Daftar Putar**

(E-SP halaman 23).

1 TOP/M : Untuk Program Asli

DVD MENU : Untuk Daftar Putar

2 Pilih item yang ingin Anda putar.



3 ENT Untuk menghapus layar.

: Hentikan pemutaran.

: Mulai memutar. (Tayangan slide: setiap file ditunjukkan selama beberapa detik.) Menunjukkan file sekarang sampai Anda mengubahnya jika ditekan sewaktu tayangan Slide.

: Pilih trek.

: Pilih folder.

: Pilih rasio aspek.

→ ... → :  
Pilih trek (dalam folder yang sama).

(dua kali) → ... → :  
Pilih folder.

: Hentikan pemutaran.

: Mulai putar/jeda (jika ditekan sewaktu pemutaran).

: Pencarian mundur/maju\*<sup>2</sup>.

: *Tekan*: Memilih trek.  
*Tahan*: Pencarian mundur/maju\*<sup>4</sup>.

: Pilih folder.

→ ... → :  
Pilih trek (dalam folder yang sama).

(dua kali) → ... → :  
Pilih folder.

: Hentikan pemutaran.

: Mulai putar/jeda (jika ditekan sewaktu pemutaran).

: Pencarian mundur/maju\*<sup>2</sup>.  
(Gerakan lamban maju\*<sup>3</sup> sewaktu jeda. Tidak ada suara yang terdengar.)  
• Gerakan lamban mundur tidak bekerja.

: *Tekan*: Memilih trek.  
*Tahan*: Pencarian mundur/maju\*<sup>4</sup> (Tidak ada suara yang terdengar).

: Pilih rasio aspek.

: Pilih saluran audio (ST: stereo, L: Kiri, R: Kanan).

→ ... → :  
Pilih trek.

**Sewaktu pemutaran PBC...**

→ ... → :  
Pilih item pada menu.  
Untuk kembali ke menu sebelumnya, tekan .

**Untuk membatalkan pemutaran PBC**

- 
- Memulai trek yang dikehendaki.  
 → ... →
  - Untuk melanjutkan kembali PBC, tekan .

: Hentikan pemutaran.

: Mulai putar/jeda (jika ditekan sewaktu pemutaran).

: Pencarian mundur/maju\*<sup>2</sup>.

: *Tekan*: Memilih trek.  
*Tahan*: Pencarian mundur/maju\*<sup>4</sup>.

→ ... → :  
Pilih trek.

\*<sup>2</sup> Kecepatan cari: x2 ⇔ x5 ⇔ x10 ⇔ x20 ⇔ x60  
 \*<sup>3</sup> Kecepatan gerakan lamban: 1/32 ⇔ 1/16 ⇔ 1/8 ⇔ 1/4 ⇔ 1/2  
 \*<sup>4</sup> Kecepatan cari: x2 ⇔ x10

## Memutarkan kembali grup bonus



Jika DVD Audio yang menyertakan “bonus group” terdeteksi, lampu indikator BONUS menyala pada layar informasi sumber.

### Untuk memutar kembali grup bonus...

#### 1 Pilih grup bonus.

- Grup bonus biasanya direkam sebagai grup terakhir.

#### 2 Masukkan nomor kode.

: Pindah posisi entri

: Pilih nomor



- “key number” (semacam sandi) untuk grup bonus tidak terbuka untuk umum. Cara mendapatkan nomor kode tergantung pada disk.

#### 3 Ikuti petunjuk interaktif yang ditunjukkan pada monitor.

## Memilih gambar diam yang dapat ditelusuri



Apabila disc yang menyertakan gambar diam yang dapat ditelusuri, terdeteksi, lampu indikator B.S.P menyala pada layar informasi sumber.

Apabila disk menunjukkan ikon pemilihan BSP, seperti atau pada layar...

#### 1 Pilih item yang ingin Anda tampilkan.



#### 2

## Menggunakan layar daftar



Anda dapat menggunakan layar Original Program [Program Asli] dan Play List [Daftar Putar] setiap saat sewaktu memutar DVD-VR dengan rekaman datanya.

#### 1 Menampilkan layar Original Program [Program Asli] dan Play List [Daftar Putar].

**TOP**

No	Date	Ch	Time	Title
1	25/04/07	4ch	19:00	JVC DVD World 2004
2	17/05/07	8ch	10:30	
3	22/05/07	8ch	17:00	Music Festival children 001
4	26/05/07	L-1	13:19	
5	20/06/07	4ch	22:00	
6	25/06/07	L-1	8:23	children 002

**DVD MENU**

No	Date	Chap	Length	Title
1	25/05/07	001	1:03:16	My JVC World
2	17/06/07	005	1:35:25	
3	20/06/07	003	0:10:23	Favorite music
4	25/06/07	001	0:07:19	children001-002

#### 2 Memilih item yang diinginkan.



Untuk menghapus layar

- 1 Nomor program/Daftar putar
- 2 Tanggal perekaman
- 3 Sumber perekaman (Stasiun TV, terminal input dari alat perekam, dsb.)
- 4 Waktu mulai perekaman
- 5 Judul program/daftar putar\*
- 6 Bar yang disorot (pemilihan sekarang)
- 7 Membuat tanggal daftar putar
- 8 Jumlah chapter yang ada dalam daftar putar
- 9 Waktu pemutaran

\* Judul program atau play list asli mungkin tidak dapat ditampilkan, bergantung alat perekamnya.

## Menikmati surround sounds

Anda dapat menikmati pemutaran multi-saluran surround melalui penguat suara depan, tengah dan surround.

- Setelah menghubungkan penguat suara tengah, pastikan penguat suara tengah tersebut diaktifkan; kalau tidak, suaranya tidak akan keluar dari penguat suara itu (☞ halaman 54).
- Modus surround bisa juga digunakan untuk "USB" dan "SD".

**MULTI:** Untuk sumber berkode multi-saluran seperti Dolby Digital\*1, DTS\*2, dan DVD Audio. (Apabila diaktifkan, "MULTI" ditunjukkan pada layar informasi sumber.)

**Dolby Pro Logic II (Movie/Music):** Untuk 2 sumber saluran, kecuali disc DivX/MPEG1/MPEG2.

### Untuk mengaktifkan surround...

1



- Anda juga dapat menggunakan AV MENU pada panel monitor.

2

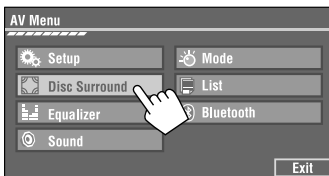

3

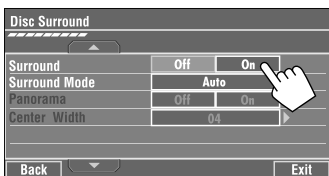

- **Off:** Menonaktifkan surround.
- **On:** Aktifkan surround → ke langkah berikut.

4

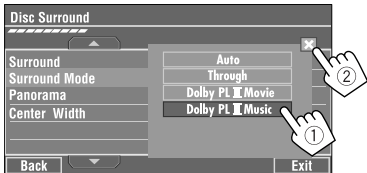

- **Auto:** Jika sinyal digital multi-channel masuk, "MULTI" surround diaktifkan. Jika sinyal 2-channel atau 2.1-channel masuk, "4CH STEREO" diaktifkan.
- **Through:** Semua sinyal channel [saluran] yang masuk akan dikirim ke penguat suara yang bersangkutan.
- **Dolby PL II Movie:** Aktifkan Dolby Pro Logic II Movie.
- **Dolby PL II Music:** Mengaktifkan Dolby Pro Logic II Music. Anda dapat menyesuaikan pengaturan <Panorama> dan <Center Width> (☞ di bawah).

### Hanya jika memilih <Dolby PL II Music>

Setelah langkah 4 di atas...

#### 1 Mengaktifkan <Panorama>.

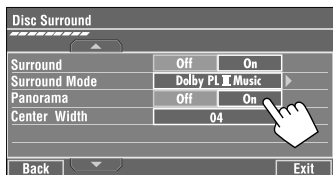

- **Panorama:** Pilih <On> untuk menambah efek suara surround.

## 2 Menyesuaikan <Center Width>.

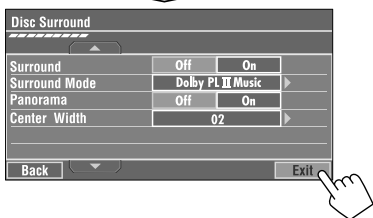
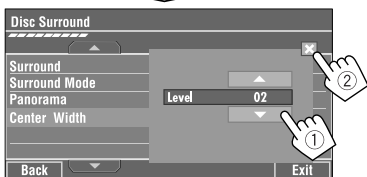
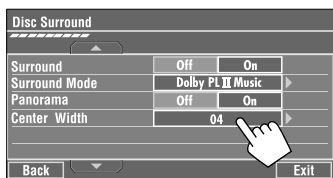

- **Center Width:** Menyesuaikan gambar tengah agar dapat didengar hanya dari penguas suara tengah, hanya dari penguas suara depan kiri/kanan sebagai gambar pusat “phantom”, atau beragam kombinasi dari semua penguas suara ini. Jika jumlahnya bertambah, efek “phantom” menjadi semakin kuat (biasanya pilih <04>).

### Pada remote kontrol:



- Anda tidak dapat mengubah pengaturan <Dolby PL II Music> dengan menggunakan remote control.

\*1 Diproduksi di bawah lisensi dari Dolby Laboratories. Dolby, Pro Logic dan simbol D-ganda merupakan merek-merek dagang dari Dolby Laboratories.

\*2 “DTS” dan “DTS Digital Surround” adalah merek dagang terdaftar dari DTS, Inc.

## Pengoperasian dengan menggunakan bar pada layar

Pengoperasian ini bisa dilakukan pada monitor dengan menggunakan remote control sewaktu memutar disc berikut ini—DVD/VCD/DivX/MPEG1/MPEG2/JPEG.

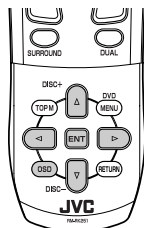

### 1 Tampilkan bar on-screen. (lihat halaman 26)

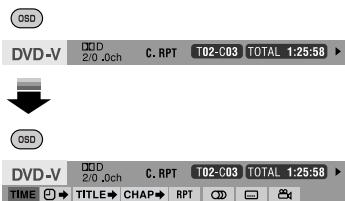

### 2 Pilih sebuah item.



### 3 Buat sebuah pilihan.

Jika menu pop-up muncul...



- Untuk memasukkan waktu/angka...

< > : Pindah posisi entri

Δ ∇ > ENT : Pilih nomor

### Untuk menghapus bar pada layar

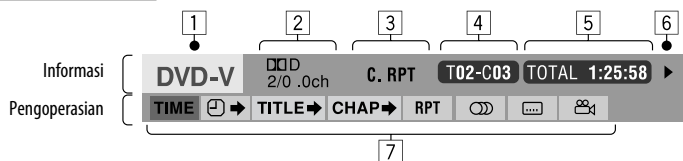

Bersambung ke halaman berikutnya

**Bar-bar On-Screen**

Di atas adalah contoh DVD Video. Item yang ditunjukkan pada bar bervariasi sesuai tipe disk.

- |  |   |
|--|---|
| <p><b>1</b> Tipe disk</p> <p><b>2</b> • DVD: Format sinyal audio<br/>• VCD: PBC</p> <p><b>3</b> Modus playback*1<br/>DVD Video:<br/>T. RPT: Mengulang judul<br/>C. RPT: Mengulang chapter<br/>DVD Audio:<br/>T. RPT: Mengulang trek<br/>DVD-VR:<br/>C. RPT: Mengulang chapter<br/>PG. RPT: Mengulang program<br/>DivX/MPEG1/MPEG2:<br/>T. RPT: Mengulang trek<br/>F. RPT: Mengulang folder<br/>JPEG:<br/>F. RPT: Mengulang folder<br/>VCD:<br/>T. RPT: Mengulang trek<br/>A. RND: All (Disc) random [Acak semua disc]<br/>T. INT: Intro trek</p> <p><b>4</b> Informasi putar ulang<br/><b>T02-C03</b> Judul/chapter sekarang<br/><b>G02-T03</b> Grup/trek sekarang<br/><b>PG001 C001</b> Program/chapter sekarang<br/><b>PL001 C001</b> Playlist/chapter sekarang<br/><b>TRACK 01</b> Trek yang sekarang<br/><b>F001-T001</b> Folder/trek yang sekarang<br/><b>F001-F001</b> Folder/file yang sekarang</p> | <p><b>5</b> Indikasi waktu<br/><b>TOTAL</b> Waktu putar yang telah lewat dari disk tersebut<br/><b>T. REM</b> Sisa waktu judul (untuk DVD)<br/>Sisa waktu disk (untuk lain)<br/><b>TIME</b> Waktu putar yang telah lewat dari bab/trek yang sekarang*2<br/><b>REM</b> Waktu yang tersisa dari bab/trek yang sekarang*2</p> <p><b>6</b> Status pemutaran<br/>▶ Putar<br/>◀/▶ Pencarian mundur/maju<br/>◀/ ▶ Mundur/maju gerak lambat<br/>   Jeda<br/>■ Henti</p> <p><b>7</b> Ikon-ikon pengoperasian<br/><b>TIME</b> Mengubah indikasi waktu (lihat <b>5</b>)<br/><b>⇨</b> Time Search [Cari Waktu] (Menjelaskan situasi tertentu dengan memasukkan waktu.)<br/><b>TITLE⇨</b> Pencarian Judul (menurut nomornya)<br/><b>CHAP⇨</b> Pencarian Chapter (menurut nomornya)<br/><b>GROUP⇨</b> Pencarian Grup (menurut nomornya)<br/><b>TRACK⇨</b> Pencarian Trek (menurut nomornya)<br/><b>RPT</b> Putar berulang*1<br/><b>INT</b> Memutar Intro*1<br/><b>RND</b> Memutar Acak*1<br/><b>🔊</b> Mengubah bahasa audio, aliran audio atau saluran audio<br/><b>🗑️</b> Mengubah atau menghapus bahasa teks<br/><b>👁️</b> Mengganti sudut pandang<br/><b>PAGE 1/ 7</b> Mengubah gambar diam yang dapat ditelusuri (halaman). Angka di indikator menunjukkan nomor halaman/jumlah halaman yang sekarang</p> |
|--|---|

\*1 🗨️ halaman 18

\*2 Tidak berlaku untuk DVD-VR

# Pengoperasian-pengoperasian Dual Zone (Zona Dual)

Anda dapat menikmati pemutaran disc pada monitor eksternal yang dihubungkan ke VIDEO OUT dan steker 2nd AUDIO OUT, sewaktu mendengarkan sumber lain yang mana pun selain "SD" dan "USB" melalui pengeras suara.

- Ketika Dual Zone (Zona Dual) sedang digunakan, anda hanya dapat mengoperasikan pemutar DVD/CD dengan menggunakan remote kontrol.

1

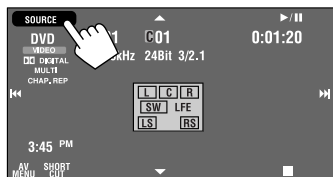

2

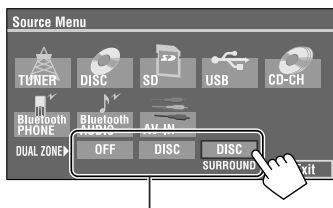

Apabila sumber utama yaitu "SD" atau "USB", "DISC" dan "DISC SURROUND" tidak dapat ditampilkan.

- **OFF:** Menonaktifkan Dual Zone (Zona Dual).
- **DISC:** Aktifkan Dual Zone (Zona Dual) tanpa memasang Headphone Surround\*.
- **DISC SURROUND:** Aktifkan Dual Zone (Zona Dual) dan memasang Headphone Surround\*.

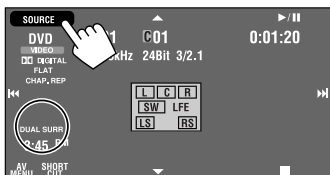

Contoh: Ketika [DISC SURROUND] sudah dipilih.

**Untuk memilih sumber yang berbeda (sumber utama) untuk mendengarkan melalui pengeras suara:**

Tekan SOURCE pada panel monitor.

- Anda tidak dapat memilih "SD" dan "USB" untuk sumber utama.
- **Dengan menggunakan tombol pada panel kontrol,** Anda dapat mengoperasikan sumber utama yang baru dipilih tanpa mempengaruhi operasi Dual Zone (Zona Dual) (DISC).

## Pada remote kontrol:

1

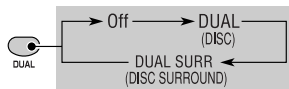

- Apabila sumber utama "SD" atau "USB" tombol DUAL tidak berfungsi.

## 2 Setel volume melalui steker 2nd AUDIO OUT.

2nd VOL



## 3 Mengoperasikan DVD/CD player.

\* Sistem surround maya headphone asli JVC. Surround ini juga berfungsi untuk sumber utama "DISC" jika "DISC SURROUND" dipilih sebagai sub-sumber. Surround ini tidak berfungsi untuk disc DivX/MPEG1/ MPEG2.

## Pengoperasian dengan menggunakan layar kontrol

### Untuk disk, kecuali DVD dan VCD:

Sewaktu Dual Zone (Zona Dual) aktif, pengoperasian ini dimungkinkan pada monitor eksternal dengan menggunakan remote control.

Layar kontrol secara otomatis muncul sewaktu Anda memasukkan disk. (Untuk DivX/MPEG1/MPEG2/JPEG; sewaktu tidak sedang memutar.)

- Apabila Dual Zone (Zona Dual) tidak aktif, Anda hanya bisa melihat layar kontrol, tapi tidak dapat mengoperasikannya.

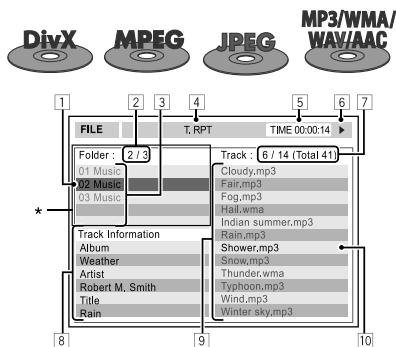

Contoh: MP3/WMA

- 1 Folder yang sekarang (bar yang disorot)
- 2 Nomor folder yang sekarang/total jumlah folder
- 3 Daftar folder
- 4 Mode putar ulang yang dapat dipilih (☞ halaman 29)
- 5 Waktu pemutaran yang sudah berjalan dari trek yang sekarang (tidak ditampilkan untuk JPEG)
- 6 Status pengoperasian
- 7 Nomor trek yang sekarang/total jumlah trek yang sekarang dalam folder yang sedang digunakan (total jumlah trek pada disk)
- 8 Informasi trek (hanya untuk MP3/WMA/WAV/AAC)
- 9 Daftar trek
- 10 Trek yang sekarang (menyorot)

\* Jika data tag menyertakan "Jacket Picture" (baseline JPEG), ini akan ditampilkan.

## Untuk memilih sebuah folder atau trek

- 1 Pilih kolom "Folder" atau kolom "Track" pada layar kontrol.



- 2 Pilih sebuah folder atau trek.

- Jika perlu, tekan **ENT** untuk memulai pemutaran.

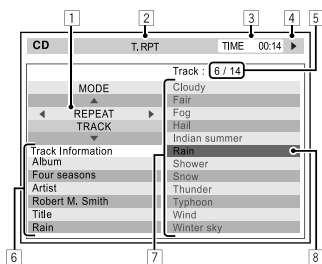

Contoh: Teks CD

- 1 Jendela pemilihan mode pemutaran: muncul apabila **OSD** ditekan (☞ halaman 29).
- 2 Mode putar ulang yang dapat dipilih (☞ halaman 29)
- 3 Waktu putar yang telah lewat dari trek yang sekarang
- 4 Status pengoperasian
- 5 Nomor track yang sekarang/total jumlah track yang sedang digunakan pada disk
- 6 Informasi trek
- 7 Daftar trek
- 8 Trek yang sekarang (bar yang disorot)

## Untuk memilih sebuah trek



- Jika perlu, tekan **ENT** untuk memulai pemutaran.

## Untuk mengubah modus pemutaran

Anda juga dapat mengubah modus pemutaran.

- Untuk CD/MP3/WMA/WAV/AAC: Intro/Ulang/Acak
- Untuk DivX/MPEG1/MPEG2/JPEG: Ulang

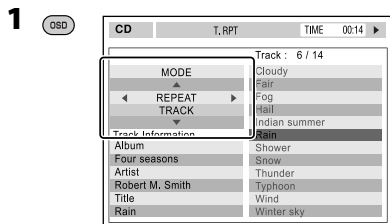

## 2 Hanya untuk CD/MP3/WMA/WAV/AAC: Pilih mode pemutaran.



## 3 Pilih opsi yang Anda kehendaki.



## 4



### Selectable playback mode

- |                   |         |                         |
|-------------------|---------|-------------------------|
| CD:               | T. RPT: | Mengulang trek          |
|                   | A. RND: | All random [Acak semua] |
|                   | T. INT: | Intro trek              |
| MP3/WMA/WAV/AAC:  |         |                         |
|                   | T. RPT: | Mengulang trek          |
|                   | F. RPT: | Mengulang folder        |
|                   | F. RND: | Acak folder             |
|                   | A. RND: | All random [Acak semua] |
|                   | T. INT: | Intro trek              |
|                   | F. INT: | Intro folder            |
| DivX/MPEG1/MPEG2: |         |                         |
|                   | T. RPT: | Mengulang trek          |
|                   | F. RPT: | Mengulang folder        |
| JPEG:             |         |                         |
|                   | F. RPT: | Mengulang folder        |

## Pengoperasian dengan menggunakan layar daftar

Untuk disc kecuali DVD, VCD dan CD Sewaktu Dual Zone (Zona Dual) aktif, pengoperasian ini dimungkinkan pada monitor eksternal dengan menggunakan remote control.

## 1 Setelah menghentikan pemutaran, tampil layar daftar.

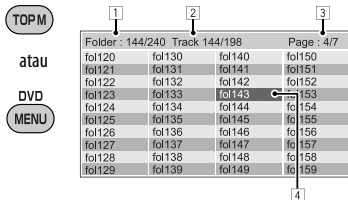

## 2 Pilih folder pada daftar tersebut.

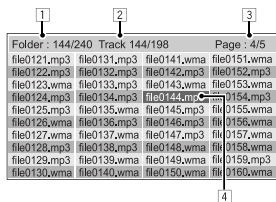

## 3 Pilih trek pada daftar tersebut.



- Untuk kembali ke daftar folder, tekan (RETURN).

- 1 Nomor folder yang sekarang/total jumlah folder
- 2 Nomor trek yang sekarang/total nomor dari trek-trek dalam folder yang sekarang
- 3 Halaman yang sekarang/total nomor dari halaman-halaman yang termasuk dalam daftar
- 4 Folder/trek yang sekarang (bar yang disorot)

# Pengoperasian SD

Unit ini dapat memutar file JPEG/MP3/WMA/WAV/AAC\*1 disimpan dalam kartu SD.

- Anda dapat mengoperasikan kartu SD dengan cara yang sama Anda mengoperasikan file pada disc (kecuali pengoperasian OSD dan yang ada di monitor eksternal). (lihat halaman 15 sampai 25)
- Semua trek dalam kartu SD akan diputar berulang-ulang sampai Anda mengubah sumbernya.
- Anda tidak dapat memilih "SD" sewaktu Dual Zone (Zona Dual) digunakan.
- Pastikan semua data penting sudah di-back up.

## 1 Buka panel monitor.

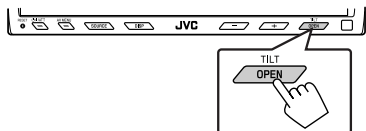

Menu <Open/Tilt> muncul.

- Ikon yang diburamkan tidak dapat digunakan saat itu.

## 2 Tekan [OPEN].

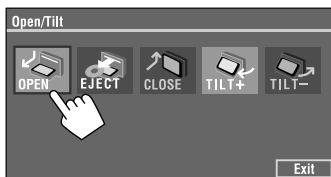

\*1 Unit ini dapat memutar kembali file AAC yang disandi menggunakan iTunes. Unit ini tidak dapat memutar kembali file AAC yang dibeli dari iTunes Store.

## 3 Sisipkan kartu SD.

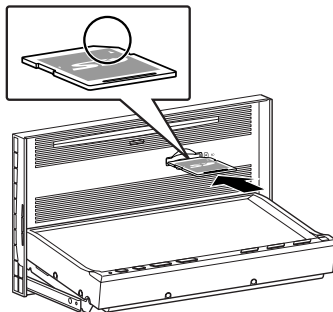

Sorong masuk kartu SD sampai Anda mendengar bunyi klik.

Sumber berubah ke "SD" dan pemutaran memulai.

## 4 Tutup panel monitor.

- Jika menu <Open/Tilt> tetap ditampilkan.

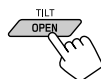

Anda juga dapat menekan [CLOSE] pada menu <Open/Tilt>.

- Jika menu <Open/Tilt> tidak ditampilkan.

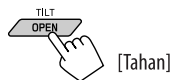

### Perhatian:

Jangan menaruh jari Anda di belakang panel monitor.

## Untuk mengeluarkan kartu SD

Sorong perlahan-lahan kartu SD.

### Perhatian:

- Jangan segera melepaskan jari Anda, karena kartu SD bisa muncul keluar dari slot pemutaran.

## Memilih mode-mode putar ulang

Anda dapat menggunakan hanya satu dari mode putar ulang berikut—Intro/Repeat/Random.

Contoh: Untuk memilih Track Repeat [Ulang Trek]



- Anda juga dapat menggunakan AV MENU pada panel monitor.

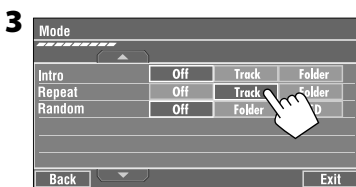
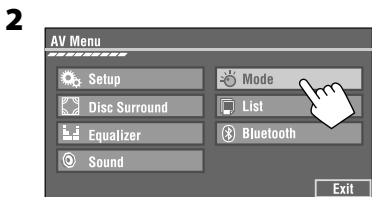

Apabila salah satu modus pemutaran dipilih, lampu indikator yang terkait menyala pada layar informasi sumber.

Untuk membatalkan, pilih <Off>.

Tipe file	Intro	Repeat	Random
	<p><b>Track:</b> Memutar 15 detik pertama dari setiap trek</p> <p><b>Folder:</b> Memutar 15 detik pertama dari trek pertama setiap folder</p>	<p><b>Track:</b> Mengulangi trek yang sekarang diputar*<sup>1</sup></p> <p><b>Folder:</b> Mengulang semua trek dari folder yang sekarang diputar</p>	<p><b>Folder:</b> Memutar secara acak semua trek dari folder yang sekarang diputar, kemudian trek dari folder berikutnya</p> <p><b>SD (All):</b> Memutar secara acak semua trek</p>
	—	<p><b>Folder:</b> Mengulangi folder yang sekarang diputar</p>	—

\*1 Anda juga dapat menggunakan [SHORT CUT] untuk mengaktifkan/nonaktifkan Pengulangan Trek.

# Pengoperasian USB

Anda dapat menghubungkan perangkat kelas penyimpanan massal USB seperti memori USB, Digital Audio Player<sup>\*1</sup>, HDD portabel, dsb. ke unit.

1

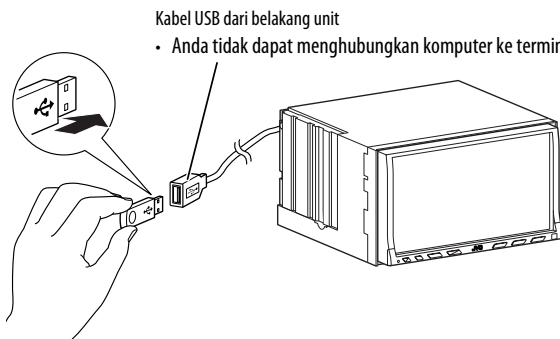

2

**Tekan [SOURCE], lalu tekan [USB].** (☞ halaman 9)

- Anda juga dapat menggunakan SOURCE pada panel monitor. Tekan berulang kali.

Unit ini dapat memutar file DivX/JPEG/MPEG1/MPEG2<sup>\*2</sup>/MP3/WMA/WAV/AAC<sup>\*3</sup> yang disimpan dalam perangkat kelas penyimpanan massal USB.

- Anda dapat mengoperasikan perangkat USB dengan cara yang sama Anda mengoperasikan file pada disc (kecuali pengoperasian OSD dan yang ada di monitor eksternal). (☞ halaman 15 sampai 25)
- Semua trek dalam perangkat USB akan diputar berulang-ulang sampai Anda mengubah sumbernya.
- Anda tidak dapat memilih "USB" sewaktu Dual Zone (Zona Dual) digunakan.
- Pastikan semua data penting sudah di-back up.

<sup>\*1</sup> Kecuali untuk JVC D. Player XA-HD500.

<sup>\*2</sup> Kecuali untuk file MPEG2 yang direkam dengan camcorder JVC Everio (kode ekstensi <.mod>).

<sup>\*3</sup> Unit ini dapat memutar kembali file AAC yang disandi menggunakan iTunes. Unit ini tidak dapat memutar kembali file AAC yang dibeli dari iTunes Store.

## Perhatian:

- Jangan gunakan perangkat USB jika akan mengganggu keamanan pengemudi Anda.
- Jangan menarik keluar dan memasang perangkat USB berulang-ulang sewaktu "Now Reading..." [Sekarang Membaca...] sedang berkedip-kedip di layar monitor.
- Jangan menghidupkan mesin mobil jika perangkat USB terhubung.
- Hentikan pemutaran sebelum melepaskan perangkat USB.
- Jangan meninggalkan perangkat USB di dalam mobil, terpapar ke sinar matahari langsung atau suhu tinggi karena bisa mengubah bentuk perangkat atau menyebabkan kerusakan.

## Memilih mode-mode putar ulang

Anda dapat menggunakan hanya satu dari mode putar ulang berikut—Intro/Repeat/Random.

Contoh: Untuk memilih Track Repeat [Ulang Trek]



- Anda juga dapat menggunakan AV MENU pada panel monitor.

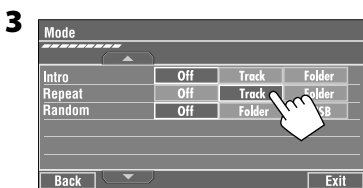
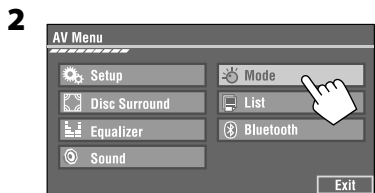

Apabila salah satu modus pemutaran dipilih, lampu indikator yang terkait menyala pada layar informasi sumber.

Untuk membatalkan, pilih <Off>.

Tipe file	Intro	Repeat	Random
MP3/WMA/WAV/AAC	<b>Track:</b> Memutar 15 detik pertama dari setiap trek <b>Folder:</b> Memutar 15 detik pertama dari trek pertama setiap folder	<b>Track:</b> Mengulangi trek yang sekarang diputar* <sup>1</sup> <b>Folder:</b> Mengulang semua trek dari folder yang sekarang diputar	<b>Folder:</b> Memutar secara acak semua trek dari folder yang sekarang diputar, kemudian trek dari folder berikutnya <b>USB (All):</b> Memutar secara acak semua trek
DivX	—	<b>Track:</b> Mengulangi trek yang sekarang diputar <b>Folder:</b> Mengulangi folder yang sekarang diputar	—
MPEG	—	<b>Folder:</b> Mengulangi folder yang sekarang diputar	—
JPEG	—	<b>Folder:</b> Mengulangi folder yang sekarang diputar	—

\*<sup>1</sup> Anda juga dapat menggunakan [SHORT CUT] untuk mengaktifkan/nonaktifkan Pengulangan Trek.

# Pengoperasian Bluetooth® — Ponsel/pemutar audio

Untuk operasi Bluetooth, Anda harus menghubungkan Bluetooth Adapter (KS-BTA200) ke jack CD changer di bagian belakang.

- Juga lihat petunjuk yang disertakan dengan Bluetooth Adapter dan perangkat Bluetooth.
- Lihat daftar (disertakan dalam kemasan) untuk negara-negara yang memungkinkan Anda menggunakan fungsi Bluetooth®.

Jika menggunakan perangkat Bluetooth ("Bluetooth PHONE" dan "Bluetooth AUDIO") melalui unit untuk pertama kali, Anda harus melangsungkan dulu koneksi nirkabel Bluetooth antara unit dan perangkat.

- Setelah koneksi terjalin, koneksi ini akan terdaftar di unit meskipun Anda menyetel ulang unitnya. Total perangkat yang dapat didaftarkan adalah lima buah.
- Hanya satu perangkat yang dapat dihubungkan setiap kali untuk masing-masing sumber ("Bluetooth PHONE" dan "Bluetooth AUDIO").

## Mendaftarkan perangkat Bluetooth

### Metode Pendaftaran (Pairing)

Gunakan salah satu item berikut dalam menu <Bluetooth> untuk mendaftarkan dan menjalin koneksi dengan perangkat.

- Pilih "Bluetooth PHONE" atau "Bluetooth AUDIO" sebagai sumber untuk mengoperasikan menu <Bluetooth>.

Item menu	Untuk melakukan
<b>Open</b> [Buka]	Menyiapkan unit untuk melangsungkan koneksi Bluetooth yang baru. Koneksi terjalin dengan mengoperasikan perangkat Bluetooth.
<b>Search</b> [Cari]	Menyiapkan unit untuk melangsungkan koneksi Bluetooth yang baru. Koneksi terjalin dengan mengoperasikan unit ini.

## Untuk mendaftarkan dengan menggunakan <Open>

**Persiapan:** Mengoperasikan perangkat untuk mengaktifkan fungsi Bluetooth.

1



- Anda juga dapat menggunakan AV MENU pada panel monitor.
- Pastikan "New Device" [Perangkat Baru] dipilih. Jika tidak, tekan [▲] atau [▼] untuk memilihnya.

2

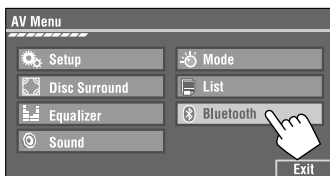

3



Ke item menu lainnya

## 4 Masukkan kode PIN (Personal Identification Number)\* ke unit.

- Anda dapat memasukkan angka berapa saja yang Anda inginkan (1 sampai 16 digit).
- \* Beberapa perangkat memiliki kode PIN sendiri. Masukkan kode PIN tertentu ke unit.

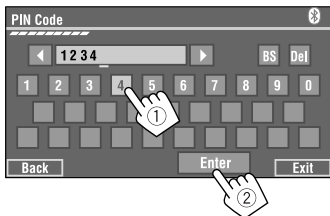

Anda hanya bisa memasukkan [0] – [9].

- [BS]: Menghapus karakter sebelumnya di belakang kursor.
- [Del]: Menghapus karakter pada kursor.
- [Enter]: Mengkonfirmasi entri.

## 5 Gunakan perangkat Bluetooth untuk menghubungkan, sewaktu “Open...” [buka...] ditampilkan di layar.

Masukkan kode PIN yang sama (seperti yang dimasukkan pada langkah di atas) pada perangkat yang akan dihubungkan.

Koneksi baru sekarang terjalin dan Anda dapat menggunakan perangkat melalui unit.

Perangkat tetap terdaftar meskipun Anda telah memutuskan perangkat. Gunakan <Connect> (atau aktifkan <Auto Connect>) untuk menghubungkan perangkat yang sama di waktu berikutnya. (☞ yang berikut, dan halaman 59).

## Untuk mendaftarkan ulang dengan menggunakan <Search>

### 1 Tekan [AV MENU] pada panel sentuh atau AV MENU pada panel monitor.

- Pastikan “New Device” [Perangkat Baru] dipilih. Jika tidak, tekan [▲] atau [▼] untuk memilihnya.

### 2 Tekan [Bluetooth].

### 3 Tekan [Search].

Unit mencari perangkat yang tersedia dan menampilkan daftarnya. (Jika tidak terdeteksi perangkat yang tersedia, “Device Unfound” [Perangkat Tak Ditemukan] akan muncul.)

### 4 Pilih perangkat yang ingin Anda hubungkan.

### 5 Masukkan kode PIN khusus dari perangkat ini.

- Lihat petunjuk yang disediakan bersama perangkat untuk memeriksa kode PIN.

### 6 Gunakan perangkat Bluetooth untuk menghubungkan, sewaktu “Connecting...” ditampilkan di layar.

Koneksi baru sekarang terjalin dan Anda dapat menggunakan perangkat melalui unit.

## Untuk menghubungkan perangkat khusus <Special Device>

### 1 Tekan [AV MENU] pada panel sentuh atau AV MENU pada panel monitor.

### 2 Tekan [Bluetooth].

### 3 Tekan [Special Device].

Unit menampilkan daftar perangkat prasetel.

### 4 Pilih perangkat yang ingin Anda hubungkan.

### 5 Gunakan <Open> (atau <Search>) untuk menghubungkan.

## Untuk menghubungkan/memutuskan perangkat terdaftar

### 1 Pilih “Bluetooth PHONE” atau “Bluetooth AUDIO”, kemudian pilih perangkat terdaftar yang Anda ingin hubungkan/putuskan.

### 2 Tekan [AV MENU] pada panel sentuh atau AV MENU pada panel monitor.

### 3 Tekan [Bluetooth].

### 4 Tekan [Connect] atau [Disconnect].

- Pilih <Connect> untuk menghubungkan perangkat yang dipilih.
- Pilih <Disconnect> untuk memutuskan perangkat yang dipilih.

## Untuk menghapus perangkat terdaftar

### 1 Pilih “Bluetooth PHONE” atau “Bluetooth AUDIO”, kemudian pilih perangkat terdaftar yang Anda ingin hapuskan.

### 2 Tekan [AV MENU] pada panel sentuh atau AV MENU pada panel monitor.

### 3 Tekan [Bluetooth].

### 4 Tekan [Delete Pair].

Layar konfirmasi, muncul. Tekan [Yes].

# Menggunakan ponsel Bluetooth

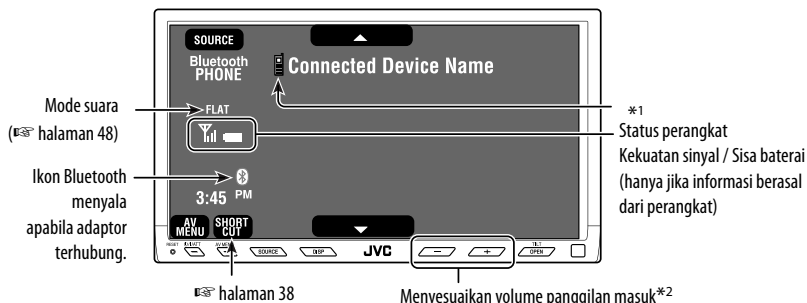

☐ : Tombol-tombol pada panel sentuh. Dalam penjelasan, semuanya ditunjukkan di dalam [ ].

[AV MENU] *Tahan:* Mengaktifkan <Voice Dialing>  
[▲ ▼] Memilih perangkat terdaftar ("New Device" [Perangkat Baru], muncul jika perangkat baru itu bisa didaftarkan.)

- \*1 Apabila ponsel dengan fungsi audio terhubung, muncul
- \*2 Penyesuaian ini tidak mempengaruhi tingkat volume dari sumber yang lain.

- 1 Tekan [SOURCE], lalu tekan [Bluetooth PHONE]. (☞ halaman 9)
    - Anda juga dapat menggunakan SOURCE pada panel monitor. Tekan berulang kali.
  - 2 Tekan [AV Menu].
    - Anda juga dapat menggunakan AV MENU pada panel monitor.
  - 3 Tekan [Bluetooth].
  - 4 Lakukan koneksi dengan perangkat, lalu lakukan panggilan (atau pengaturan dengan menggunakan menu <Bluetooth>).
- ☞ halaman 58 dan 59

## Apabila ada panggilan masuk...

Sumber berubah ke "Bluetooth PHONE" secara otomatis.

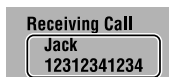

Nama dan nomor telepon (jika ada)

## Apabila <Auto Answer> [Jawab Otomatis] diaktifkan...

Unit akan menjawab panggilan masuk secara otomatis. (☞ halaman 59)

## Apabila <Auto Answer> [Jawab Otomatis] dinonaktifkan...

### Untuk menjawab panggilan masuk

- Tekan tombol apa pun pada panel monitor (kecuali /I/ATT atau +/-).
- Tekan pesan yang ditampilkan pada panel sentuh.

### Untuk mengakhiri panggilan

- Tekan terus tombol apa pun pada panel monitor (kecuali /I/ATT atau +/-).
- Tekan terus pesan yang ditampilkan pada panel sentuh.
- Anda dapat menyesuaikan volume mikrofon. (☞ halaman 59)

### Apabila SMS masuk...

Jika telepon selular kompatibel dengan SMS (Short Message Service), Anda dapat membaca pesan pada monitor.

- Anda tidak dapat mengedit atau mengirim pesan melalui unit.

### Apabila <Message Info> disetel ke <Auto>...

Dering unit dan layar berikut ini ditampilkan pada monitor untuk memberitahu Anda mengenai penerimaan pesan. (☞ halaman 59)



Untuk membaca pesan, tekan [Yes].

Sumber diubah ke "Bluetooth PHONE".

Untuk membaca pesan nanti, tekan [No].

- Pesan disimpan ke <Message> → <Unread>. (☞ halaman 58)

### Apabila <Message Info> disetel ke <Manual>...

Mengakses daftar pesan untuk membaca pesan. (☞ halaman 59)

### Untuk membuat panggilan



- Anda juga dapat menggunakan AV MENU pada panel monitor.

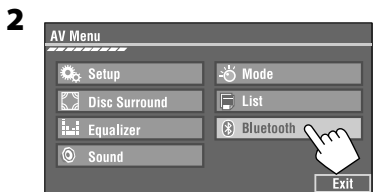

### 4 Memilih metode panggilan, lalu panggil.

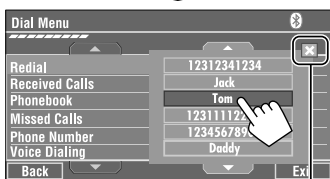
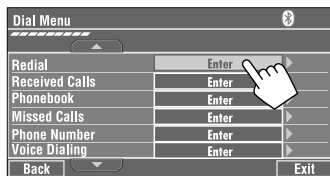

Batal

- **Redial [Sambung Ulang]:** Menampilkan daftar nomor telepon yang sudah Anda panggil.
- **Received Calls [Panggilan Diterima]:** Menampilkan daftar panggilan yang diterima.
- **Phonebook [Buku telepon]:** Menampilkan buku telepon ponsel yang terhubung.
- **Missed Calls [Panggilan Tak Terjawab]:** Menampilkan daftar panggilan yang tidak terjawab.
- **Phone number [Nomor telepon]:** Menunjukkan layar entri nomor telepon → "Cara memasukkan nomor telepon" (☞ halaman 38).
- **Voice Dialing [Menyambung dengan Suara]:** (Hanya jika ponsel yang terhubung dilengkapi sistem pengenalan suara): → Ucapkan nama yang ingin Anda panggil.

### Untuk menghentikan deringan (membatalkan panggilan keluar)

Tekan terus tombol apa pun pada panel monitor (kecuali ⏻/I/ATT atau +/-).

## Cara memasukkan nomor telepon

- Anda tidak dapat menggunakan remote control untuk memasukkan nomor telepon.



Anda dapat memasukkan [0] – [9], [\*], [#] (hingga 32 nomor)

- **[BS]**: Menghapus karakter sebelumnya di belakang kursor.
- **[Del]**: Menghapus karakter pada kursor.
- **[Preset]**: Ke Daftar Prasetel. Anda dapat menyetel terlebih dulu nomor yang dimasukkan dengan memilih nomor prasetel (lihat halaman 39)
- **[Dial]**: Memanggil nomor yang dimasukkan.

- Anda dapat mudah mengakses <Dial Menu> dengan menekan **[SHORT CUT]** pada panel sentuh, lalu...



Anda juga bisa mengakses <Dial Menu> dengan menekan terus SOURCE pada panel monitor.

- Anda dapat mudah mengaktifkan <Voice Dialing> dengan menekan **[SHORT CUT]** pada panel sentuh, lalu...



Anda juga dapat mengaktifkan <Voice Dialing> dengan menekan terus **[AV MENU]**.

## Untuk menyambung ulang nomor yang sudah disambung

1

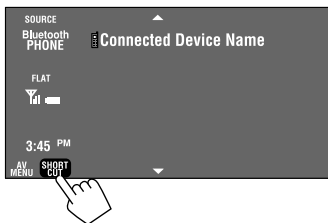

2

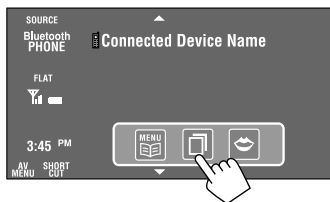

3

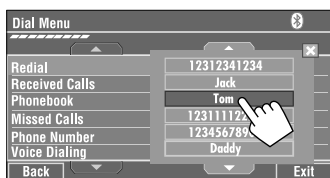

Apabila menggunakan remote control, Anda dapat menampilkan daftar <Redial> setiap saat (kecuali jika Dual Zone (Zona Dual) sedang digunakan).



## Memprasetel nomor telepon

Anda dapat membuat hingga enam nomor telepon prasetel.

- Pilih nomor telepon yang ingin Anda prasetel dari <Phonebook> [Buku Telepon], <Redial> [Sambung Ulang], <Received Calls> [Panggilan Diterima], atau <Missed Calls> [Panggilan Tak Terjawab].

- 1 Tekan [AV MENU] pada panel sentuh atau AV MENU pada panel monitor.
- 2 Tekan [Bluetooth].
- 3 Tekan [Dial Menu], lalu...

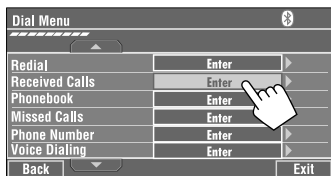

Contoh: Memilih <Received Calls>

- Pilih nomor telepon yang akan disimpan.



- Pilih nomor yang telah diatur sebelumnya.

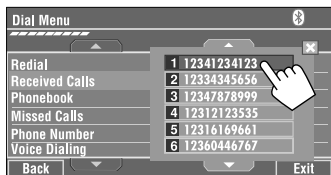

Sekarang "Tom" disimpan dalam prasetel no. 1.

## Untuk memanggil nomor prasetel

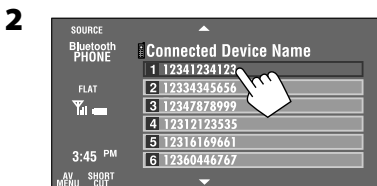
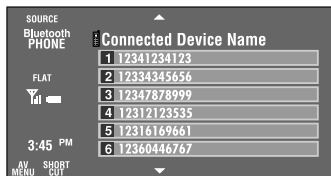
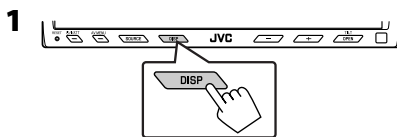

Anda dapat menggunakan tombol berikut pada remote control untuk mengoperasikan telepon Bluetooth.



- Menampilkan <Dial Menu>/ Menjawab panggilan masuk.
- Menampilkan atau daftar <Redial> jika ditekan terus (apa pun sumber yang sekarang aktif).



: Mengakhiri panggilan.





: Setel volume.





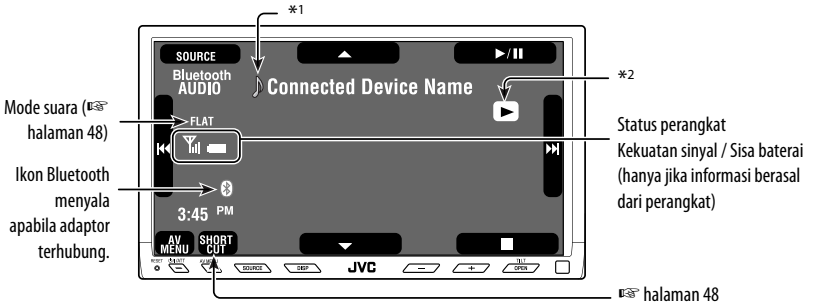





- 1 2 3 : Membuat panggilan ke nomor prasetel.  
4 5 6

# Menggunakan pemutar audio Bluetooth



 : Tombol-tombol pada panel sentuh. Dalam penjelasan, semuanya ditunjukkan di dalam [ ].

-  /   Memulai dan menunda pemutaran
-   Pencarian mundur/maju
-   Memilih perangkat terdaftar ("New Device" [Perangkat Baru], muncul jika perangkat baru itu bisa didaftarkan.)\*3

\*1 Apabila ponsel dengan fungsi audio terhubung, muncul .



\*2 Menunjukkan tombol ditekan. Ini mungkin berbeda dari status pengoperasian.

\*3 Anda tidak bisa memilih "New Device" [Perangkat Baru] jika audio player Bluetooth terhubung.

- 1 Tekan [SOURCE], lalu tekan [Bluetooth AUDIO].** (FLAT halaman 9)
  - Anda juga dapat menggunakan SOURCE pada panel monitor. Tekan berulang kali.
- 2 Mulai memutar.**

- Lihat halaman 34 untuk menghubungkan perangkat baru.
- Lihat halaman 35 untuk menghubungkan/memutuskan perangkat terdaftar.
- Lihat halaman 35 untuk menghapus perangkat terdaftar.

Anda dapat menggunakan tombol-tombol berikut pada remote kontrol untuk pengoperasian audio Bluetooth.

-  : Memulai dan menunda pemutaran.
-  : Lompat mundur/maju.
-  : Setel volume.

**Informasi Bluetooth:**  
Jika ingin menerima informasi lebih lanjut mengenai Bluetooth, kunjungi situs web JVC kami.

# Mendengarkan CD changer

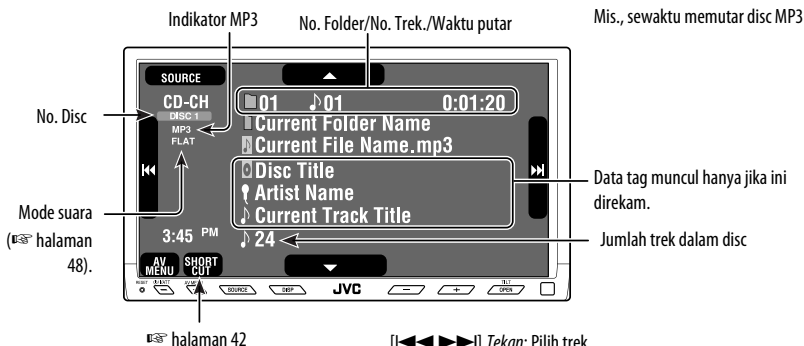

: Tombol-tombol pada panel sentuh. Dalam penjelasan, semuanya ditunjukkan di dalam [ ].

- [◀◀▶▶▶▶] Tekan: Pilih trek  
Tahan: Pencarian mundur/maju
- [▲▼] Tekan: Pilih folder (hanya untuk MP3)  
Tahan: Tampilkan Daftar Disk

Disarankan untuk menggunakan JVC CD-changer yang kompatibel-MP3 dengan alat penerima anda.

- Anda dapat memutar hanya disk CD (CD-DA) dan MP3.

## Persiapan:

Pastikan <Changer> dipilih untuk <External Input>. (☞ halaman 56)

**1** Tekan [SOURCE], lalu tekan [CD-CH]. (☞ halaman 9)

- Anda juga dapat menggunakan SOURCE pada panel monitor. Tekan berulang kali.



- Anda juga dapat menggunakan AV MENU pada panel monitor.

**3** Tampilkan Disk List [Daftar Disk].



**4** Memilih disk untuk diputar.



Untuk ke daftar lain

- Jika memilih disc MP3, daftar Track folder yang sekarang akan muncul. Anda bisa memilih trek, lalu mulai memutar. (☞ juga halaman 19)

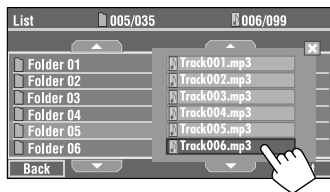

- Jika memilih folder dalam daftar, Anda bisa mulai memutar trek pertama dari folder.

## Memilih mode-mode putar ulang

Anda dapat menggunakan hanya satu dari mode putar ulang berikut—Intro/Ulang/Acak.

Contoh: Untuk memilih Track Repeat disc MP3 (untuk CD,  halaman 18.)

- 1 Tekan [AV MENU] pada panel sentuh atau AV MENU pada panel monitor.
- 2 Tekan [Mode].
- 3

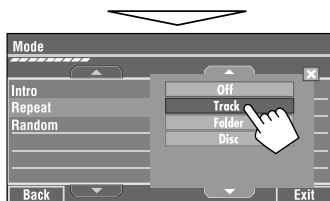
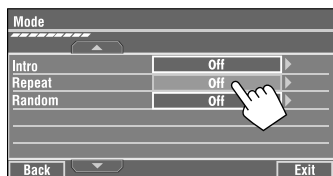

Apabila salah satu modus pemutaran dipilih, lampu indikator yang terkait menyala pada layar informasi sumber.

Untuk membatalkan, pilih <Off>.

Tipe disk	Intro	Repeat	Random
	<b>Track:</b> Memutar 15 detik pertama dari setiap trek <b>Disc:</b> Memutar 15 detik pertama dari trek pertama dari semua disk yang dimuatkan	<b>Track:</b> Mengulangi trek yang sekarang diputar <b>Disc:</b> Mengulang semua trek dari disk yang sekarang diputar	<b>Disc:</b> Memutar secara acak semua trek dari disk yang sekarang diputar <b>All:</b> Secara acak memutar semua trek dari semua disk yang dimuatkan
	<b>Track:</b> Memutar 15 detik pertama dari setiap trek <b>Folder:</b> Memutar 15 detik pertama dari trek pertama setiap folder <b>Disc:</b> Memutar 15 detik pertama dari trek pertama dari semua disk yang dimuatkan	<b>Track:</b> Mengulangi trek yang sekarang diputar <b>Folder:</b> Mengulang semua trek dari folder yang sekarang diputar <b>Disc:</b> Mengulang semua trek dari disk yang sekarang diputar	<b>Folder:</b> Memutar secara acak semua trek dari folder yang sekarang diputar, kemudian trek dari folder berikutnya <b>Disc:</b> Memutar secara acak semua trek dari disk yang sekarang diputar <b>All:</b> Secara acak memutar semua trek dari semua disk yang dimuatkan

- Anda dapat dengan mudah mengaktifkan atau menonaktifkan Track Repeat dengan menekan [SHORT CUT] pada panel sentuh, lalu...

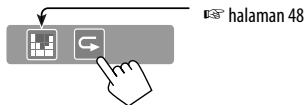

Anda dapat menggunakan tombol berikut pada remote control untuk mengoperasikan CD changer.

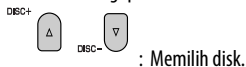

: Memilih folder (Hanya MP3).



: Tekan: Pilih trek.  
Tahan: Pencarian mundur/maju.

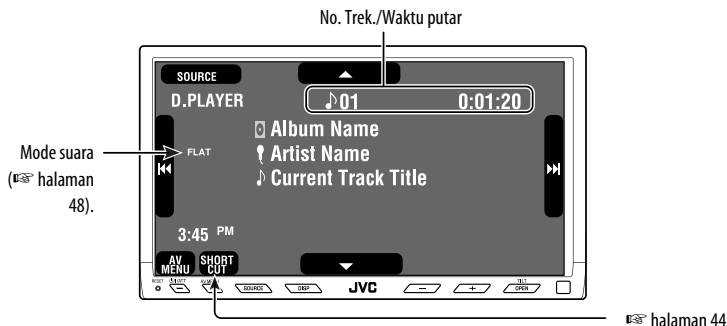

**[FLAT]** : Tombol-tombol pada panel sentuh. Dalam penjelasan, semuanya ditunjukkan di dalam [ ].

- [|◀▶|] Tekan: Pilih trek  
Tahan: Pencarian mundur/maju
- [▲] Masuk ke menu player
- [▼] Jeda/stop pemutaran  
• Untuk melanjutkan, tekan lagi.

Anda harus menghubungkan adaptor antarmuka (KS-PD100 untuk Apple iPod atau KS-PD500 untuk JVC D. player) ke jack CD changer di bagian belakang.

## Persiapan:

Pastikan <iPod> atau <D. player> dipilih untuk <External Input>. (⏮ halaman 56).

## 1 Tekan [SOURCE], lalu tekan [iPod] atau [D.PLAYER] (⏮ halaman 9)

Playback [Pemutaran] berjalan otomatis.

- Anda juga dapat menggunakan SOURCE pada panel monitor. Tekan berulang kali.

## 2 Tekan [◀◀] atau [▶▶] untuk memilih trek.

## Memilih trek dari menu player

- 1 Tekan [▲] untuk masuk ke menu player. "SEARCH" berkedip-kedip pada monitor selama pengoperasian menu.
  - Mode ini akan dibatalkan jika tidak ada pengoperasian selama sekitar 5 detik.

## 2 Tekan [◀◀] atau [▶▶] untuk memilih item yang dikehendaki.

Tekan: Pilih sebuah item.

Tahan: Melewatkan 10 item setiap kali jika ada lebih dari 10 item.

### Untuk iPod:

Playlists ↔ Artists ↔ Albums ↔ Songs  
↔ Genres ↔ Composers ↔ (kembali ke permulaan)

### Untuk D. player:

Playlist ↔ Artist ↔ Album ↔ Genre ↔  
Track ↔ (kembali ke permulaan)

**3 Tekan [▼] untuk mengkonfirmasi pemilihan.**

**4 Ulangi langkah 2 dan 3 untuk memilih trek.**

- Setelah trek dipilih, pemutaran akan dimulai.
- Untuk kembali ke menu sebelumnya, tekan [▲].

## Memilih mode-mode putar ulang

**1**

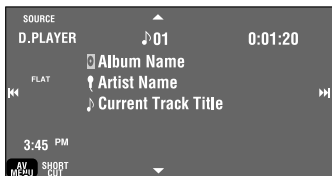

- Anda juga dapat menggunakan AV MENU pada panel monitor.

**2**

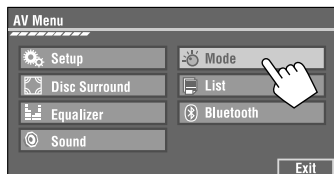

**3 Pilih opsi yang sesuai.**

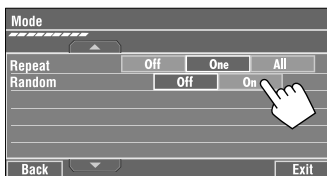

<b>Repeat</b>	<b>One:</b> Fungsinya sama seperti "Repeat One" atau "Repeat Mode → One". <b>All:</b> Fungsinya sama seperti "Repeat All" atau "Repeat Mode → All".
<b>Random</b>	<b>Album:</b> Fungsinya sama seperti "Shuffle Albums" untuk iPod. <b>Song/On:</b> Fungsinya sama seperti "Shuffle Songs" atau "Random Play → On".

- Apabila modus pemutaran dipilih, lampu indikator yang bersangkutan menyala secara bergantian pada monitor.

**Untuk membatalkan, pilih <Off>.**

- Anda dapat dengan mudah mengaktifkan atau menonaktifkan Track Repeat dengan menekan [SHORT CUT] pada panel sentuh, lalu...

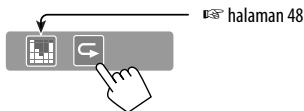

halaman 48

# Menggunakan komponen eksternal lainnya

## AV-INPUT

Anda dapat menghubungkan komponen eksternal ke steker LINE IN/VIDEO IN.

Judul yang ditentukan (☞ halaman 49)      Mode suara (☞ halaman 48)

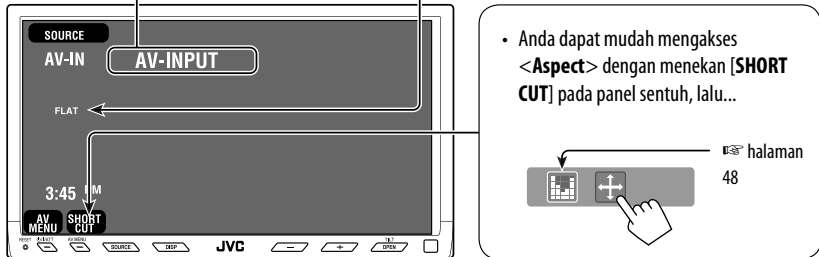

- Anda dapat mudah mengakses <Aspect> dengan menekan [SHORT CUT] pada panel sentuh, lalu...

☞ halaman 48

 : Tombol-tombol pada panel sentuh. Dalam penjelasan, semuanya ditunjukkan di dalam [ ].  
Tombol-tombol ini juga berfungsi jika tidak ditunjukkan pada panel sentuh (sewaktu menonton film di layar).

- 1 Tekan [SOURCE], lalu tekan [AV-IN]. (☞ halaman 9)
  - Anda juga dapat menggunakan SOURCE pada panel monitor. Tekan berulang kali.
- 2 Hidupkan komponen yang telah tersambung dan mulai memainkan sumber tersebut.

## Untuk menampilkan tombol pengoperasian (☞ halaman 17) sewaktu menonton pemutaran film



Sentuh layar (Bagian tengah).

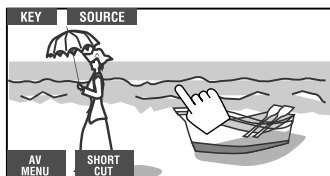
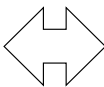

Sentuh layar (Bagian tengah).

- Jika tidak ada pengoperasian selama sekitar 5 detik, tombol pengoperasian menghilang.
- [KEY] tidak berfungsi apabila sumbernya "AV-IN".

## Layar navigasi

Anda juga dapat menghubungkan Navigation System [Sistem Navigasi] ke steker VIDEO IN agar dapat mengawasi layar navigasi.

### Persiapan:

Pastikan <Navigation> dipilih untuk <AV Input>. (☞ halaman 55)

## Untuk menampilkan layar navigasi (dan mendengarkan bimbingan navigasi)\*

- 1 Tekan DISP pada panel monitor berulang-ulang. (☞ halaman 9)

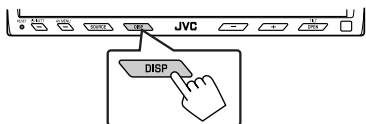

- Rasio aspek layar navigasi ditetapkan ke <Full> apa pun pengaturan <Aspect> (☞ halaman 52).

\* Jika Navigation System dilengkapi dengan fungsi bimbingan suara.

## Untuk menampilkan tombol pengoperasian (☞ halaman 17) sewaktu menayangkan layar navigasi

- Tombol pengoperasian yang ditampilkan pada layar, beragam di antara sumber-sumber pemutaran.

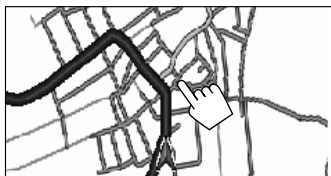

Sentuh layar (Bagian tengah).

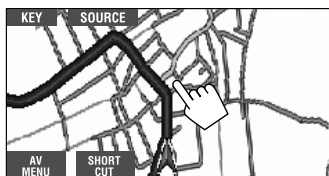
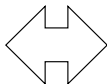

Sentuh layar (Bagian tengah).

- Jika tidak ada pengoperasian selama sekitar 5 detik, tombol pengoperasian menghilang.
- Tombol-tombol di atas ini kecuali [KEY] juga berfungsi jika tidak ditunjukkan pada panel sentuh (sewaktu menayangkan layar navigasi).

### Bila <Navigation> dipilih untuk <AV Input>. (☞ halaman 55)

- Anda dapat menggunakan sumber <AV-IN> untuk mendengarkan sumber audio yang dihubungkan ke steker LINE IN.
- Beberapa pesan status seperti tingkat volume, tidak akan muncul di monitor.

## EXT-INPUT

Anda dapat menghubungkan komponen eksternal pada jack CD changer di bagian belakang dengan menggunakan Line Input Adapter [Adaptor Input Saluran]—KS-U57 (tidak disediakan) atau AUX Input Adapter [Adaptor Input AUX]—KS-U58 (tidak disediakan).

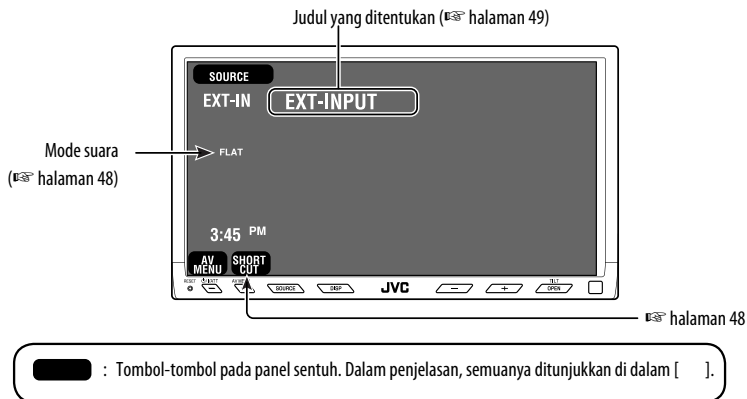

### Persiapan:

Pastikan <External> dipilih untuk <External Input>. (☞ halaman 56)

- 1 Tekan [SOURCE], lalu tekan [EXT-IN].** (☞ halaman 9)
  - Anda juga dapat menggunakan SOURCE pada panel monitor. Tekan berulang kali.
- 2 Hidupkan komponen yang telah tersambung dan mulai memainkan sumber tersebut.**

# Penyeragaman suara

Anda dapat memilih mode suara prasetel untuk sumber 2-saluran.

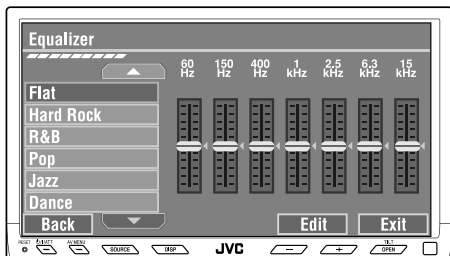

Sewaktu memutar sumber apa pun selain "Bluetooth PHONE", menu **<Equalizer>** dapat mudah diakses dengan menekan [SHORT CUT] pada panel sentuh, lalu...



## Memilih mode suara



- Anda juga dapat menggunakan AV MENU pada panel monitor.

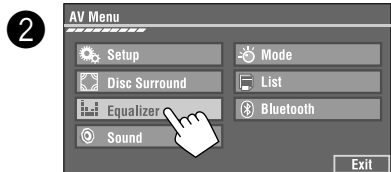

## 3 Pilih sebuah mode suara.

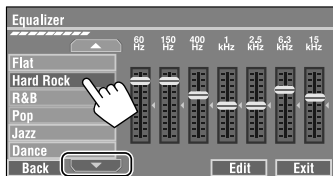

Bergerak ke 6 modus suara lainnya

- Untuk angka setelan prasetel dari setiap modus suara, lihat halaman 66.
- Untuk sumber multi-saluran, mode suara untuk sementara dibatalkan.

## Menyimpan setelan Anda sendiri

Anda dapat menyimpan setelan Anda ke dalam User1, User2, dan User3.

## 1 Ulangi langkah 1 dan 2, kemudian dalam langkah 3...

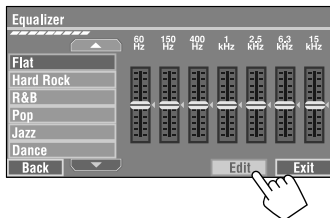

## 2 Menyesuaikan (1), lalu simpan (2).

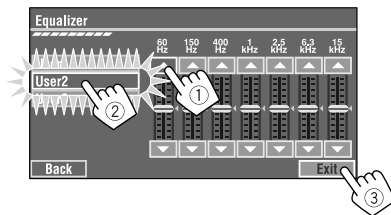

Contoh: Sewaktu menyimpan ke [User2].

# Menetapkan judul untuk sumber

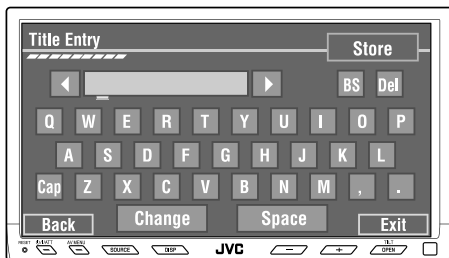

Tombol-tombol pada panel sentuh. Dalam penjelasan, semuanya ditunjukkan di dalam [ ].

Anda dapat menentukan judul sebagai berikut.

<b>Stasiun FM/AM</b>	Sampai 16 karakter—hingga 30 karakter.
<b>AV-IN EXT-IN</b>	Sampai 16 karakter

## 1 Pilih sumbernya. (☞ halaman 9)

- Untuk stasiun FM/AM: Pilih jalur, kemudian tala ke stasiun.

## 2 Menampilkan layar <Title Entry>.



- Anda juga dapat menggunakan AV MENU pada panel monitor.

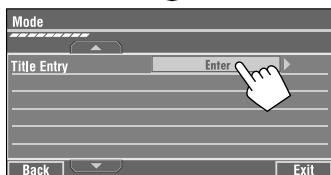
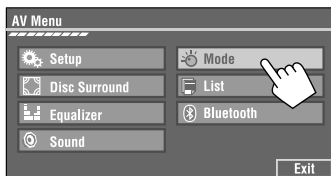

## 3 Tetapkan sebuah judul.

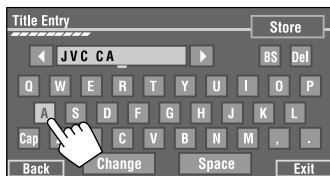

Anda bisa memasukkan hingga 16 karakter (untuk karakter yang tersedia, ☞ halaman 65).

- **[Store]**: Konfirmasi entri.
- **[<|>]**: Memindahkan kursor.
- **[BS]**: Menghapus karakter sebelumnya di belakang kursor.
- **[Del]**: Menghapus karakter pada kursor.
- **[Cap]**: Mengubah huruf besar/kecil.
- **[Space]**: Memasukkan spasi.
- **[Change]**: Mengubah set karakter.

## 4 Prosedur selesai.

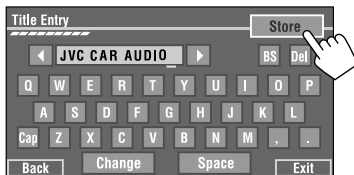

# Pengoperasian menu

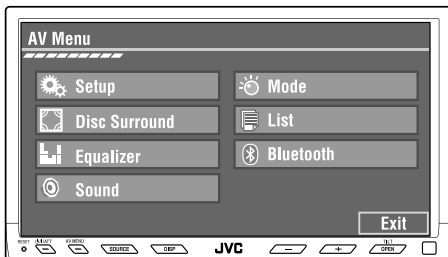

Langkah berikut adalah salah satu prosedur yang mendasar. Beberapa pengaturan tidak membuka jendela sub-pengaturan, tetapi hanya memilih opsi yang akan mengubah pengaturan.

Contoh: Mengubah pengaturan <AV Input>

**1**

A close-up of the 'AV MENU' button on the monitor's control panel. The button is rectangular with 'AV MENU' on the left and 'SHORT CUT' on the right. A hand icon points to the button.

- Anda juga dapat menggunakan AV MENU pada panel monitor.

**2**

The AV Menu screen with the 'Setup' option highlighted by a hand icon. Below this screen, a downward arrow indicates the next step.

The Setup screen showing various settings. A hand icon points to the 'Setup' button at the top left. The settings listed are: Demonstration (Off/On), Wall Paper (Wrap Drive), Color (Blue), Scroll (Off/Once/Auto), Dimmer (Auto), and Dimmer Time Set (6 PM to 7 AM). 'Back' and 'Exit' buttons are at the bottom.

Item yang tidak tersedia akan ditampilkan dalam bayangan.

**3**

The Setup screen with 'AV Input' highlighted by a hand icon. A hand icon also points to the 'Exit' button at the bottom right. A downward arrow indicates the next step.

The AV Input sub-menu with 'Audio & Video' highlighted by a hand icon. A hand icon also points to the 'Exit' button at the bottom right. A downward arrow indicates the next step.

The AV Input sub-menu with a context menu open over the 'Audio & Video' option. The context menu has three items: 'Off', 'Audio & Video', and 'Navigation'. A hand icon points to 'Audio & Video' (labeled '2') and another hand icon points to 'Navigation' (labeled '1'). A hand icon also points to the 'Exit' button at the bottom right. A downward arrow indicates the next step.

The AV Input sub-menu with 'Navigation' selected. The 'Navigation' option is now highlighted. A hand icon points to the 'Exit' button at the bottom right.



## Setup









Permulaan: **Yang digaris-bawahi**

Item menu	Pengaturan-pengaturan yang terpilih, [halaman referensi]
Demonstration	<b>Off:</b> Batal. <b>On:</b> Aktifkan demo pada monitor. Untuk menghentikannya sementara, sentuh layar monitor.
Wall Paper	Anda dapat memilih gambar latar belakang monitor. <b>Warp Drive, X-Face, Wave, Ring</b>
Color	Anda dapat memilih warna <Wall Paper>. <b>Blue, Sky, Green, Red, Yellow, Purple, Dark-Blue, Dark-Sky, Dark-Green, Dark-Red, Brown, Black</b>
Scroll	<b>Off:</b> Batal. <b>Once:</b> Menggulung informasi disk sekali. <b>Auto:</b> Mengulangi penggulungan (selang waktu 5-detik). • Menekan terus <b>DISP</b> pada panel monitor akan menggulirkan informasi, apa pun pengaturannya.
Dimmer	<b>Off:</b> Batal. <b>On:</b> Mengaktifkan peredup. <b>Auto:</b> Meredupkan monitor ketika anda menghidupkan lampu utama.*1 <b>Dimmer Time Set :</b> Mengaktifkan pengaturan Dimmer Time [Waktu Peredup] di bawah ini.
Dimmer Time Set	Menyetel waktu On/Off Dimmer.
Dimmer Level	Anda dapat memprasetel kecerahan dimmer. <b>00</b> (paling terang) hingga <b>10</b> (paling gelap); Permulaan <b>05</b>
Bright	Anda dapat menyesuaikan kecerahan untuk membuat tampilan jelas dan terbaca. <b>-15</b> (paling terang) hingga <b>+15</b> (paling gelap); Permulaan <b>00</b>
Picture Adjust*2	Anda dapat menyesuaikan yang berikut ini untuk membuat monitor terlihat bersih dan jelas untuk menonton pemutaran ulang gambar. Pengaturan akan disimpan—satu untuk “DISC/SD/USB” (umum) dan yang lainnya untuk “AV-IN”. <b>-15</b> sampai <b>+15</b> ; Permulaan <b>0</b> <b>Bright:</b> Sesuaikan jika gambar terlalu terang atau terlalu gelap. <b>Contrast:</b> Sesuaikan kontras. <b>Color:</b> Sesuaikan warna gambar—lebih cerah atau lebih gelap. <b>Tint:</b> Sesuaikan nuansa warna jika warna kulit manusia tidak tampak alami. • Tekan [▲] atau [▼] untuk menyesuaikan.

\*1 Diperlukan sambungan kabel ILLUMINATION CONTROL [KONTROL SINAR]. (☞ Manual Pemasangan/Penyambungan.)

\*2 Hanya bisa disesuaikan apabila sumbernya yaitu disc/SD/USB yang berisi gambar atau film, atau “AV-IN”.

Bersambung ke halaman berikutnya

Item menu	Pengaturan-pengaturan yang terpilih, [halaman referensi]			
<b>Aspect</b> *3  <div style="display: flex; align-items: center;"> <div style="writing-mode: vertical-rl; transform: rotate(180deg); font-weight: bold; margin-right: 5px;">Tampilan</div> <div style="border: 1px solid black; width: 15px; height: 15px; margin-right: 5px;"></div> </div>	Anda dapat mengubah rasio aspek gambar.			
	<b>Rasio aspek sinyal masuk</b>			
	<b>4:3</b>	<b>16:9</b>		
	<b>Regular:</b> Untuk gambar asli 4:3			
	<b>Full:</b> Untuk gambar asli 16:9			
<b>Panorama:</b> Untuk menayangkan film 4:3 secara alami di layar lebar				
<b>Auto:</b>	<ul style="list-style-type: none"> <li>• Untuk "DISC": Rasio aspek secara otomatis dipilih dan diselaraskan dengan sinyal masuk.</li> <li>• Untuk sumber video yang lain: Perbandingannya ditetapkan ke <b>&lt;Regular&gt;</b>.</li> </ul>			
<b>Language</b> *4	Pilih bahasa petunjuk yang ditampilkan pada monitor. <b>English, Spanish, French, German, Italian, Dutch, Swedish, Danish, Russian</b>			
<b>NTSC/PAL</b> *4	Memilih sistem warna dari monitor eksternal yang terhubung— <b>NTSC, PAL</b> . <ul style="list-style-type: none"> <li>• Matikan daya lalu hidupkan lagi untuk memberlakukan pengaturan baru.</li> </ul>			
<b>Time Set</b>	Permulaan <b>1:00AM</b> ,  [8]			
<div style="display: flex; align-items: center;"> <div style="writing-mode: vertical-rl; transform: rotate(180deg); font-weight: bold; margin-right: 5px;">Jam</div> <div style="border: 1px solid black; width: 15px; height: 15px; margin-right: 5px;"></div> </div>	Memilih sistem 12-jam atau 24-jam. <b>12 Hours, 24 Hours</b> ,  [8]			
	<b>OSD Clock</b>	Apabila <b>&lt;On&gt;</b> dipilih, waktu jam ditampilkan pada pemutaran gambar/film. Waktu jam ditampilkan dalam ukuran besar di layar animasi (  hal. 9) <b>Off, On</b>		

\*3 Tidak dapat disesuaikan apabila tidak ada gambar yang diperlihatkan.

\*4 Setelah Anda mengubah pengaturan bahasa petunjuk, matikan lalu nyalakan kembali agar pengaturan Anda berlaku.

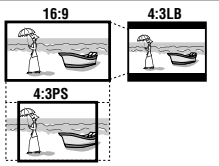
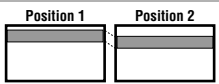
Item menu	Pengaturan-pengaturan yang terpilih, [halaman referensi]
<b>Menu Language</b> *5	Memilih bahasa menu disk permulaan; Permulaan <b>English</b> (☞ juga halaman 66).
<b>Audio Language</b> *5	Memilih bahasa audio permulaan; Permulaan <b>English</b> (☞ juga halaman 66).
<b>Subtitle</b> *5	Memilih bahasa subtitle permulaan atau menghapus subtitle ( <b>Off</b> ); Permulaan <b>English</b> (☞ juga halaman 66).
<b>OSD Language</b> *5	Pilih bahasa pada layar yang digunakan untuk monitor eksternal yang dihubungkan ke steker VIDEO OUT; Permulaan <b>English</b> .
<b>Monitor Type</b> *5 	Pilih jenis monitor untuk menonton film layar lebar pada monitor eksternal Anda. <b>16:9</b> : Pilih, apabila rasio aspek monitor eksternal 16:9. <b>4:3LB</b> (Letterbox)/ <b>4:3PS</b> (Pan Scan): Pilih, apabila rasio aspek monitor eksternal 4:3. Rujuk ke gambar di sebelah kiri untuk melihat bagaimana gambar ditampilkan pada monitor.
<b>OSD Position</b> *5 	Pilih posisi bar pada layar, ☞ [25]. <b>1</b> : Posisi tertinggi <b>2</b> : Posisi lebih rendah
<b>File Type</b> *5	Memilih jenis file pemutaran apabila disc/SD/USB berisikan jenis file yang berbeda. Anda bisa menyimpan pengaturan ini secara terpisah untuk tiap sumber — "DISC/SD/USB". <b>Audio</b> : Pemutaran file audio. <b>Picture</b> : Memutar file JPEG. <b>Video</b> : Memutar file DivX/MPEG1/MPEG2. (Tidak berlaku pada "SD")
<b>Divx Regist. (Registration)</b> *5	Unit ini memiliki Kode Registrasi sendiri. Setelah Anda memutar kembali file yang merekam Kode Registrasi, maka Kode Registrasi unit ini akan ditimpa demi melindungi hak cipta.
<b>D. (Dynamic) Range Compres. (Compression)</b> *5	Anda dapat menikmati suara yang dahsyat pada level volume rendah sewaktu memutar perangkat lunak Dolby Digital. <b>Auto</b> : Pilih ini untuk menerapkan efek pada perangkat lunak multisaluran yang dikodekan. <b>On</b> : Pilih ini untuk selalu menggunakan fungsi ini.

\*5 Hanya dapat dipilih untuk "DISC", "SD" dan "USB". (Pemutaran berhenti apabila Anda mengubah pengaturan.)

## Item menu

## Pengaturan-pengaturan yang terpilih, [halaman referensi]

## Speaker Size\*5

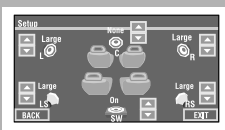

Anda dapat menyesuaikan pengaturan ukuran penguat suara. Jika mengubah ukuran penguat suara, maka penguat suara di layar mengubah ukurannya. Apabila <None> atau <Off> dipilih, penguat suara diburamkan.

- **L/R (Depan): Small, Large**
- **C (Tengah): None, Small, Large**
- **LS/RS (Surround): None, Small, Large**
- **SW (Subwoofer): On, Off**
- Ukuran penguat suara: <Large> untuk diameter 13-cm atau lebih; <Small> untuk 13 cm atau kurang.
- Jika memilih <Large> atau <Small> untuk penguat suara yang tidak terhubung, sinyal masuk untuk penguat suara yang tidak terhubung itu tidak akan keluar dari penguat suara lain manapun.
- Penguat suara depan dan penguat suara surround tidak dapat disesuaikan secara terpisah untuk penguat suara kiri dan kanan.

## Terlepas dari pengaturan di atas...

- Tidak ada suara yang keluar dari subwoofer sewaktu memutar Dolby Pro Logic II Movie atau Music jika penguat suara depan disetel ke <Large>.
- Tidak ada suara yang keluar dari penguat suara tengah sewaktu surround dinonaktifkan.

## Speaker Level\*6

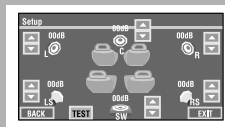

Anda dapat menyesuaikan tingkat keluaran penguat suara yang diaktifkan (☞ <Speaker Size> di atas), memonitor nada tes.

**L/C/R/RS/SW\*7/LS:** menyesuaikan tingkat output setiap speaker dalam kisaran **-10dB** sampai **+10dB**; Permulaan **00dB**.

- Tekan [**Test**] untuk mengaktifkan atau menonaktifkan nada tes.

## Speaker Distance\*6, 8

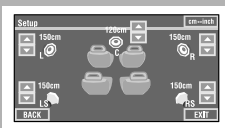

Anda dapat menyesuaikan pengaturan waktu keluaran penguat suara.

**L/C/R/RS/LS:** menyesuaikan jarak penguat suara dari posisi dengar dalam kisaran **15cm/6 inci** hingga **600 cm/240 inci** dalam langkah 15-cm/6-inci; Permulaan **120 cm/48 inci** (untuk penguat suara tengah), **150 cm/60 inci** (untuk penguat suara lainnya).





- Tekan [**cm↔inch**] untuk mengubah unit ukuran—**cm** dan **inci**.

\*5 Hanya dapat dipilih untuk "DISC", "SD" dan "USB". (Pemutaran berhenti apabila Anda mengubah pengaturan.)

\*6 Hanya dapat dipilih untuk "DISC", "SD" dan "USB".



\*7 Pengaturan level subwoofer ini hanya berlaku apabila surround diaktifkan. (☞ juga halaman 24)

\*8 Pengaturan ini tidak berlaku untuk MPEG1/MPEG2 dan DivX dengan trek audio MP3.

	Item menu	Pengaturan-pengaturan yang terpilih, [halaman referensi]
Penala 	IF Band Width	<p><b>Auto:</b> Penambahan selektivitas radio untuk menekan gangguan noise di antara stasiun-stasiun dekat. (Efek stereo mungkin hilang).</p> <p><b>Wide:</b> Kecuali apabila ada gangguan dari stasiun radio yang berdampingan, kualitas suara/bunyi tidak akan menurun dan efek stereo tidak akan hilang.</p>
	AV Input* <sup>9</sup>	<p>Anda dapat menentukan penggunaan steker LINE IN dan VIDEO IN.</p> <p><b>Off:</b> Pilih, apabila tidak ada komponen yang dihubungkan ("AV-IN" dilompati sewaktu memilih sumber).</p> <p><b>Audio&amp;video:</b> Pilih ini apabila menghubungkan komponen AV seperti VCR.  [45]</p> <p><b>Audio:</b> Pilih apabila menghubungkan komponen audio seperti digital audio player.  [45]</p> <p><b>Navigation:</b> Pilih sewaktu menghubungkan Sistem Navigasi.  [46]</p>
Masukan 	Camera Input* <sup>10</sup>	<p><b>Off:</b> Pilih apabila tidak ada kamera tampilan belakang yang dihubungkan ke steker CAMERA IN.</p> <p><b>Normal:</b> Pilih apabila menghubungkan kamera tampilan belakang ke steker CAMERA IN. Foto dari kamera ditampilkan saat diambil.</p> <p><b>Mirror:</b> Proyeksi gambar yang diambil oleh kamera ditampilkan pada monitor.</p> <ul style="list-style-type: none"> <li>• Sewaktu gambar melalui kamera diperlihatkan di monitor, tidak ada pesan yang akan ditampilkan.</li> </ul>

\*<sup>9</sup> Tidak dapat dipilih apabila "AV-IN" dipilih sebagai sumber.

\*<sup>10</sup> Sambungan kabel lampu belakang diwajibkan. Lihat Manual Pemasangan/Penyambungan (bagian yang terpisah). Pandangan belakang melalui kamera muncul di monitor pada rasio aspek <Full> (terlepas dari penyetelan rasio aspek) sewaktu persneling diubah menjadi posisi mundur (R). Sewaktu menekan DISP pada panel kontrol, atau ketika Anda beralih ke posisi lain selain posisi pembalik (R), layar tampilan belakang dikosongkan.

	Item menu	Pengaturan-pengaturan yang terpilih, [halaman referensi]
Masukan	 External Input* <sup>11</sup>	Untuk menghubungkan komponen eksternal ke jack CD changer di bagian belakang. <b>Changer/iPod/D. player</b> * <sup>12</sup> : CD changer, iPod atau D. player ☞ [41, 43] <b>External</b> : Apa pun selain yang di atas. ☞ [47] • Untuk menghubungkan adaptor Bluetooth, pengaturan ini tidak diperlukan. Ini terdeteksi secara otomatis.
		<b>Beep</b> <b>Off</b> : Batal. <b>On</b> : Mengaktifkan suara sentuh-kunci.
Lain-lain	 Telephone Muting* <sup>13</sup>	<b>Off</b> : Batal. <b>Muting1, Muting2</b> : Pilih salah satu yang membungkam suara sementara menggunakan telepon selular.
	Power LED Flash	<b>Off</b> : Batal. <b>On</b> : Apabila tombol pemacu dimatikan, lampu pada tombol  /I/ATT berkilat-kilat.
	TouchPanel Sens.	Mengubah kepekaan panel sentuh. Jika angkanya menurun, kepekaan semakin tinggi. 1/2/3; Permulaan <u>2</u>
	Initialize	Inisialisasi semua pengaturan yang sudah Anda buat dalam <AV Menu>. Tekan terus [Enter] untuk mengawali pengaturan, lalu mereset unit anda (☞ halaman 3).

\*<sup>11</sup> Tidak dapat dipilih apabila komponen yang terhubung ke jack CD changer, dipilih sebagai sumber.

\*<sup>12</sup> Nama komponen yang terdeteksi melalui jack CD changer akan diperlihatkan.

\*<sup>13</sup> Diperlukan sambungan timah TEL MUTING [MEREDAM TELP]. Lihat Manual Pemasangan/Penyambungan (bagian yang terpisah).



### Disc Surround\*<sup>14</sup>

Item menu	Pengaturan-pengaturan yang terpilih, [halaman referensi]
Surround	<b>On, Off</b> , ☞ [24]
Surround Mode	<b>Auto, Through, Dolby PLII Movie, Dolby PLII Music</b> , ☞ [24]
Panorama	<b>On, Off</b> , ☞ [24]
Center Width* <sup>15</sup>	<b>00 ke 07</b> ; Permulaan <b>04</b> , ☞ [25]

\*<sup>14</sup> Hanya dapat dipilih untuk "DISC", "SD" dan "USB".

\*<sup>15</sup> Pengaturan ini hanya berlaku apabila penguat suara tengah diaktifkan.



## Equalizer

Flat/Hard Rock/R&B/Pop/Jazz/Dance/Country/Reggae/Classic/User1/User2/User3, [48]

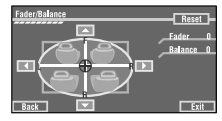

## Sound

Item menu	Pengaturan-pengaturan yang terpilih, [halaman referensi]
<b>Fader/Balance</b> 	<p>Menyesuaikan seimbangan output fader—pengeras suara antara pengeras suara depan dan belakang.</p> <ul style="list-style-type: none"> <li>• Paling atas—depan saja (F6)</li> <li>• Paling bawah—belakang saja (R6)</li> </ul> <p>Apabila menggunakan sistem dua-pengeras suara, setel fader ke tengah (0). Menyesuaikan seimbangan output balance—pengeras suara antara pengeras suara kiri dan kanan.</p> <ul style="list-style-type: none"> <li>• Paling kiri—hanya kiri (L6)</li> <li>• Paling kanan—hanya kanan (R6)</li> </ul>
<b>Volume Adjust</b>	<p>Menyesuaikan dan menyimpan tingkat volume penyesuaian-otomatis untuk masing-masing sumber, membandingkan dengan tingkat volume FM. Tingkat volume akan secara otomatis bertambah atau berkurang apabila Anda mengubah sumber.</p> <p>–12 ke +12; Permulaan <b>00</b></p> <ul style="list-style-type: none"> <li>• Untuk Disk/SD/USB: Tingkat penyesuaian otomatis pada umumnya digunakan apabila memutar file DivX/MPEG1/MPEG2/MP3/WMA/WAV/AAC</li> </ul>
<b>Subwoofer Phase</b>	Pilih < <b>Normal</b> > atau < <b>Reverse</b> >, yang mereproduksi suara yang lebih baik.
<b>Subwoofer Level</b> <sup>*16</sup>	Setel level keluaran subwoofer. Level (Tingkat): –06 ke +08; Permulaan <b>00</b>
<b>High Pass Filter</b>	<b>Through:</b> Pilih apabila subwoofer tidak dihubungkan. <b>On :</b> Pilih apabila subwoofer dihubungkan.
<b>Crossover</b>	Sesuaikan frekuensi seberangan antara pengeras suara depan/belakang dan subwoofer. <b>80Hz, 120Hz, 150Hz</b>
<b>Amplifier Gain</b>	Anda dapat mengganti level volume maksimum dari alat penerima ini. <b>Off:</b> Menonaktifkan penguat-penguat yang terpasang tetap di dalam. <b>Low:</b> VOL 00 hingga 30 (Pilih ini jika daya maksimum pengeras suara kurang dari 50 W) <b>High:</b> VOL 00 hingga 50
<b>Rear Speaker</b> <sup>*17</sup>	Anda dapat mengaktifkan/menonaktifkan pengeras suara belakang. <b>Off, On</b>

<sup>\*16</sup> Pengaturan tingkat subwoofer hanya berlaku apabila surround dinonaktifkan. ( juga halaman 24)

<sup>\*17</sup> Pengaturan ini hanya berlaku apabila Dual Zone (Zona Dual) diaktifkan. ( juga halaman 27)



Item menu	Pengaturan-pengaturan yang terpilih, [halaman referensi]
Mono	Hanya untuk FM. ( <b>Off, On</b> ),  [10]
DX/Local	Hanya untuk FM. ( <b>Local, DX</b> ),  [11]
SSM	Hanya untuk FM. Tekan terus untuk menjalankan SSM.  [11]
Title Entry	Hanya untuk stasiun FM/AM, AV-IN, dan EXT-IN.  [49]
Intro/Repeat/Random	[18, 31, 33, 42, 44]

\*18 Item yang tercantum di bawah <Mode> bervariasi di antara sumber pemutaran.



### List

Untuk "DISC": Daftar Folder dan Daftar Trek ( halaman 19)

Untuk "CD-CH": Daftar Disc, Daftar Folder dan Daftar Trek ( halaman 41)

- Untuk sumber pemutaran lainnya, Anda dapat menampilkan daftar dengan menekan DISP pada panel monitor ( halaman 9)



### Bluetooth\*19

Item menu	Pengaturan-pengaturan yang terpilih, [halaman referensi]
Dial Menu *20	Pilih metode untuk melakukan panggilan.  [37]
Message*21	Anda dapat membaca pesan dari riwayat pesan berikut ini. <b>Unread:</b> Pesan yang belum Anda baca. <b>Read:</b> Pesan yang sudah Anda baca. <b>Unsent:</b> Pesan yang belum Anda kirim. <b>Sent:</b> Pesan yang sudah Anda kirim. <ul style="list-style-type: none"> <li>• Jumlah pesan di dalam setiap history [riwayat] juga diperlihatkan pada monitor.</li> </ul>
Open	[34]
Search	[35]
Special Device	Hanya untuk "New Device". Menunjukkan daftar perangkat Bluetooth yang memerlukan prosedur khusus untuk melangsungkan koneksi Bluetooth. Pilih perangkat yang ingin Anda hubungkan. <ul style="list-style-type: none"> <li>• Setelah memilih perangkat, gunakan &lt;Open&gt; atau &lt;Search&gt; ( atas) untuk koneksi.</li> <li>• Setelah koneksi dilakukan, koneksi terdaftar dalam unit. Anda dapat menghubungkan unit dan perangkat dengan menggunakan &lt;Connect&gt; ( halaman 59) pada waktu berikutnya.</li> </ul>

Item menu	Pengaturan-pengaturan yang terpilih, [halaman referensi]
<b>Connect</b>	Hanya untuk perangkat yang terdaftar. Setelah memilih perangkat di antara perangkat yang terdaftar (☞ halaman 34, 35), langsunjkan koneksi dengan perangkat ini.
<b>Disconnect</b>	Hanya untuk perangkat yang terhubung. Putus hubungan perangkat yang sedang aktif sebelum menghubungkan perangkat yang lain.
<b>Delete Pair</b>	Hanya untuk perangkat yang terdaftar. Hapus perangkat yang terdaftar.

\*19 Hanya dapat dipilih untuk "Bluetooth PHONE" atau "Bluetooth AUDIO". Pilih perangkat (atau "New Device") sebelum mengoperasikan menu.

\*20 Hanya untuk drive yang dihubungkan untuk "Bluetooth PHONE".

\*21 Hanya dapat dipilih apabila sumbernya "Bluetooth PHONE" dan perangkatnya kompatibel dengan SMS (Short Message Service).

Apabila mengoperasikan perangkat Bluetooth, lihat juga petunjuk yang disediakan bersama perangkat.

	Item menu	Pengaturan-pengaturan yang terpilih, [halaman referensi]
Pengaturan	<b>Auto Connect</b> *22	Apabila unit diaktifkan, koneksi dilakukan secara otomatis dengan... <b>Off:</b> Tidak ada perangkat Bluetooth. <b>Last:</b> Perangkat Bluetooth yang terakhir dihubungkan. <b>Order:</b> Perangkat Bluetooth terdaftar yang tersedia yang ditemukan pertama kali.
	<b>Auto Answer</b> *23	<b>Off:</b> Unit tidak menjawab panggilan secara otomatis. Menjawab panggilan secara manual. <b>On:</b> Unit akan menjawab panggilan masuk secara otomatis. <b>Reject:</b> Unit menolak semua panggilan masuk.
	<b>Message Info</b> *23	<b>Auto:</b> Unit memberitahukan adanya pesan yang masuk dengan berdering dan menampilkan – "Receiving Message" [Menerima Pesan]. Untuk membaca pesan, ☞ halaman 37. <b>Manual:</b> Unit tidak memberitahukan adanya pesan yang masuk.
	<b>MIC Setting</b> *23	Menyesuaikan volume mikrofon yang dihubungkan ke adaptor Bluetooth. <b>01/02/03</b> Permulaan <b>02</b>
	<b>Version</b> *24	Versi perangkat lunak dan perangkat keras Bluetooth diperlihatkan.

\*22 Hanya dapat dipilih untuk "Bluetooth PHONE".

\*23 Hanya untuk drive yang dihubungkan untuk "Bluetooth PHONE". Tidak dapat dipilih apabila "New Device" yang dipilih.

\*24 Jika ingin menerima informasi lebih lanjut mengenai Bluetooth, kunjungi situs web JVC kami.

## Pengembunan uap air

Uap air mungkin mengembun pada lensa di dalam alat penerima dalam kasus-kasus berikut:

- Setelah menyalakan pemanas di dalam mobil.
  - Jika ini menjadi sangat lembab di dalam mobil.
- Jika ini terjadi, alat penerima mungkin mengalami kesalahan fungsi. Keluarkan disk atau biarkan alat penerima hidup untuk beberapa jam sampai uap air menguap.

## Bagaimana menangani disk-disk

**Ketika memindahkan sebuah disk dari wadahnya**, tekan ke bawah penahan tengah dari wadah tersebut dan angkat disk keluar, pegang CD pada bagian pinggir.

Penahan tengah



- Selalu memegang disk pada bagian pinggir. Jangan menyentuh permukaan yang terekamnya.

**Ketika menyimpan sebuah disk ke dalam wadahnya**, dengan baik masukkan disk tersebut ke sekeliling penahan tengah (dengan permukaan yang tercetak menghadap ke atas).

- Pastikan untuk menyimpan disk-disk ke dalam wadah-wadahnya setelah digunakan.

## Untuk menjaga disk-disk bersih

Sebuah disk yang kotor mungkin tidak dapat diputar secara benar.

Jika sebuah disk menjadi kotor, lap dengan sebuah kain lembut dalam satu garis lurus dari tengah ke pinggir.



- Jangan menggunakan suatu pelarut (sebagai contoh pembersih rekaman konvensional, semprotan, tiner, bensin, dll) untuk membersihkan disk-disk.

## Untuk memutar disk-disk baru

Disk-disk baru mungkin mempunyai bagian-bagian yang kasar di sekitar bagian dalam dan luar pinggiran disk. Jika disk seperti ini digunakan, alat penerima ini mungkin menolak disk tersebut.



Untuk menghilangkan bagian-bagian kasar ini, gosok pinggiran-pinggiran dengan sebuah pensil atau pena, dll.

### Jangan gunakan disk-disk berikut:

Disk melengkung



Stiker



Bekas stiker



Label yang menonjol

# Lebih lagi tentang alat penerima ini

## Umum

### Menghidupkan daya

- Dengan menekan SOURCE pada panel monitor, Anda juga dapat menghidupkan daya. Jika sumber sudah siap, pemutaran dimulai.

## FM/AM

### Menyimpan stasiun-stasiun dalam memori

- Apabila SSM sudah berakhir, stasiun radio yang diterima diprasetel pada No. 1 (frekuensi terendah) hingga No. 6 (frekuensi tertinggi).

## Disk

### Umum

- Dalam manual ini, kata-kata “track” dan “file” secara bergantian digunakan.
- Radio ini juga dapat memutar ulang disk-disk 8 cm.
- Unit ini hanya dapat memutar file CD audio (CD-DA) jika jenis file (MP3/WMA/WAV/AAC) yang berbeda direkam dalam disk yang sama.
- Alat penerima ini dapat menampilkan hanya 1 byte karakter. Tidak ada karakter-karakter lain dapat secara benar ditampilkan.

### Menyisipkan sebuah disk

- Apabila disc dimasukkan terbalik, atau tidak ada file yang dapat diputar, tulisan “Cannot play this disc Check the disc” [Tidak dapat memutar disc ini. Cek disc], muncul di monitor. Keluarkan disc.

### Mengeluarkan sebuah disk

- Jika “No disc” [Tidak ada disc] muncul setelah Anda mengeluarkan disc, masukkan lagi disc atau pilih sumber pemutaran yang lain.
- Jika disk yang dikeluarkan tidak dipindahkan dalam 15 detik, disk secara otomatis akan disisipkan kembali ke dalam tempat pemuatan untuk melindunginya dari debu.

## Indikator pengeras suara/sinyal DVD

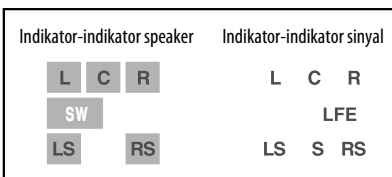

- Indikator pengeras suara—kotak di sekeliling huruf menyala biru apabila pengeras suara yang bersangkutan disetel ke <Large> atau <Small>.
- Indikator pengeras suara tengah—segi empat di sekeliling “C” bersinar biru terang apabila pengeras suara tengah disetel ke <Large> atau <Small> dan apabila surround diaktifkan.
- Suara yang keluar dari pengeras suara yang indikatornya menyala.
- Indikator SW menyala apabila <SW (Subwoofer)> disetel ke <On>.
- Indikator sinyal menunjukkan sinyal masuk—L (kiri depan) / R (kanan depan) / C (tengah) / LFE (efek frekuensi rendah) / LS (surround kiri) / RS (surround kanan) / S (surround mono).
- Jika pengeras suara diaktifkan, tetapi sinyal yang bersangkutan ke pengeras suara tidak masuk, indikator sinyal berubah warna dari putih ke hitam, untuk menandakan tidak ada sinyal masuk.

## Mengganti sumber

- Jika Anda mengubah sumber sementara Dual Zone (Zona Dual) tidak diaktifkan, pemutaran pun akan berhenti tanpa mengeluarkan disk. Pada waktu berikutnya anda memilih “DISC” untuk sumber putar ulang, disk mulai memutar dari tempat dimana telah dihentikan sebelumnya.

## Memutar disk Recordable/Rewritable

- Unit ini dapat mengenali sebanyak 5 000 file dan 250 folder (maksimum 999 file per folder).
- Gunakan hanya disk-disk yang telah “diselesaikan” (finalized).
- Alat penerima ini dapat memutar ulang disk-disk multisesi; bagaimanapun, sesi-sesi yang belum ditutup akan dilewati sementara memutar.
- Unit ini dapat mengenali sebanyak 25 karakter nama file/folder.
- Beberapa disk atau file mungkin tidak dapat diputar ulang karena karakteristik atau kondisi rekamannya.

## Memutar audio DVD

- Sejumlah DVD Audio melarang downmix. Apabila memutar disc semacam itu, “LR ONLY” muncul di monitor dan unit memutar sinyal depan kiri dan depan kanan.
- “MULTI CH” muncul di monitor setelah bunyi bip jika Anda mencoba memutar disc multi-channel [multi saluran] dan Surround disetel ke <Off>.

## Memutar DVD-VR

- Unit ini tidak dapat memutar file proteksi CPRM (Content Protection for Recordable Media).
- Untuk rincian tentang format DVD-VR dan daftar putar, rujuk ke petunjuk yang disediakan dengan perlengkapan perekaman.

## **■ Pemutaran file**

### Memutar file DivX

- Unit ini dapat memutar kembali file DivX dengan kode ekstension <.divx>, <.div>, <.avi> (tanpa menghiraukan bentuk huruf—besar/kecil).
- Unit ini mendukung file DivX files yang memiliki resolusi 720 x 576 piksel atau kurang.
- Unit ini mendukung DivX 6.x, 5.x, 4.x dan 3.11.
- Audio stream [Pengaliran audio] harus sesuai standar MP3 atau Dolby Digital.
- File yang disandi dalam mode pemindaian saling mengait, mungkin tidak dapat diputar kembali secara tepat.
- Maksimum bit rate untuk sinyal video (rata-rata) adalah seperti berikut ini.
  - DVD: 4 Mbps
  - USB: 2 Mbps

## Memutar file MPEG1/MPEG2

- Unit ini dapat memutar kembali file MPEG1/ MPEG2 dengan kode ekstension <.mpeg>, <.mpeg> atau <.mod>\*.
  - \* <.mod> adalah kode ekstensi yang digunakan untuk file MPEG2 yang direkam oleh camcorder JVC Everio.
- Format stream [pengaliran] harus sesuai dengan MPEG system/program stream. Format file harus MP@ML (Main Profile at Main Level)/SP@ML (Simple Profile at Main Level)/MP@LL (Main Profile at Low Level).
- Audio stream [Pengaliran audio] harus sesuai standar MPEG1 Audio Layer-2 atau Dolby Digital.
- Maksimum bit rate untuk sinyal video (rata-rata) adalah seperti berikut ini.
  - DVD: 4 Mbps
  - USB: 2 Mbps

## Memutar file JPEG

- Unit ini dapat memutar kembali file JPEG dengan kode ekstension <.jpg> atau <.jpeg>.
- Anda dianjurkan untuk merekam file pada resolusi 640 x 480.
- Unit ini hanya dapat memutar file JPEG baseline. File JPEG Progressive dan file JPEG lossless tidak dapat diputar.

## Memutar file MP3/WMA/WAV/AAC

- Alat penerima ini dapat memutar ulang file-file dengan kode perpanjangan <.mp3>, <.wma>, <.wav> atau <.m4a> (mengabaikan jenis huruf—huruf besar/kecil).
- Alat receiver ini dapat memutar kembali file yang memenuhi kondisi di bawah:
  - Kecepatan bit:
    - MP3/WMA: 32 kbps — 320 kbps
    - AAC: 16 kbps — 320 kbps
  - Frekuensi sampling:
    - 48 kHz, 44.1 kHz, 32 kHz (untuk MPEG1)
    - 24 kHz, 22.05 kHz, 16 kHz (untuk MPEG2)
    - 48 kHz, 44.1 kHz, 32 kHz, 22.05 kHz (untuk WMA)
    - 44.1 kHz (untuk WAV)
    - 48 kHz, 44.1 kHz (untuk AAC)

- Unit ini dapat memperlihatkan ID3 Tag Versi 1.0/1.1/2.2/2.3/2.4 (untuk MP3). Unit ini juga menunjukkan Tag WAV/WMA/AAC.
- Alat penerima ini dapat memutar ulang file yang terekam dalam VBR (Kecepatan bit variabel).
- File yang direkam dalam VBR memiliki selisih indikasi waktu yang berlalu.
- Alat penerima ini tidak dapat memutar ulang file berikut:
  - File-file MP3 yang disandikan dalam sebuah format MP3i dan MP3 PRO.
  - File MP3 disandikan dengan Lapisan 1/2.
  - File-file WMA disandikan dengan tanpa kerusakan, profesional, dan format-format suara.
  - File WMA yang tidak berdasarkan Windows Media® Audio.
  - File-file WMA/AAC perlindungan-copy dengan DRM.
  - File AAC disandi dengan menggunakan aplikasi lain selain iTunes.
  - File AAC yang dibeli dari iTunes Store.
  - File yang memiliki data seperti AIFF, ATRAC3, dll.
- Apabila tidak ada file yang dapat diputar dalam kartu SD, atau file belum diformat dengan benar, “Cannot play this SD card Check the SD card” [Tidak dapat memutar kartu SD ini. Cek kartu SD], muncul di monitor. Ganti kartu SD. Jangan menarik keluar atau memasangkan kartu SD sewaktu “Now Reading...” [Sekarang Membaca...] sedang diperlihatkan pada monitor.
- Unit ini dapat mengenali sebanyak 5 000 file dan 250 folder (maksimum 999 file per folder).
- Unit ini dapat mengenali sebanyak 25 karakter nama file/folder.

## USB

### Menikmati surround sounds

- Jika <Surround> disetel ke <On>, pemutaran surround “MULTI” secara otomatis dijalankan untuk disc penyandian multi-channel.
- Anda tidak dapat mengaktifkan surround untuk MPEG multi-channel DVD Video, DivX 2-saluran dan sumber MPEG 2-saluran. Jika <Surround> disetel ke <On>, suara stereo akan dipancarkan hanya melalui pengeras suara depan. “FRONT 2CH” muncul di layar informasi sumber.
- Apabila “FIX” muncul di layar informasi sumber, tidak akan ada suara yang keluar dari subwoofer.
- Apabila <Surround> disetel ke <Auto>, downsampling dilakukan untuk DVD Video (hanya LPCM), DVD-VR (hanya LPCM), dan DVD Audio pada fs=88.2 kHz/96 kHz dan yang lebih tinggi.

## SD

- Jika “No SD Card” [Tidak Ada Kartu SD] muncul setelah mengeluarkan kartu SD, memasang ulang kartu SD atau memilih sumber pemutaran yang lain.

- Jika “No USB Device” [Tidak Ada Perangkat USB] yang muncul setelah melepaskan perangkat, Pasang kembali perangkat tersebut atau pilih sumber pemutaran yang lain.
- Apabila tidak ada file yang dapat diputar dalam perangkat USB, atau file belum diformat dengan benar, “Cannot play this device Check the device” [Tidak dapat memutar perangkat ini. Cek perangkat], muncul di monitor.
- Unit tidak dapat mengenali perangkat USB yang pentarafannya di luar 5 V dan tidak melampaui 500 mA.
- Sewaktu memutar dari perangkat USB, urutan pemutaran mungkin berbeda dengan player lainnya.
- Unit ini mungkin tidak dapat memutar beberapa perangkat USB atau file karena karakteristiknya atau kondisi rekamannya.
- Bergantung pada bentuk perangkat USB dan port sambungan, beberapa perangkat USB mungkin tidak dapat dipasang dengan baik atau mungkin sambungannya longgar.
- Apabila menghubungkan perangkat USB, rujuk juga petunjuknya.
- Setiap kali hanya dapat menghubungkan satu perangkat USB ke unit. Jangan menggunakan hub USB.
- Unit ini mungkin tidak dapat mengenali perangkat USB yang terhubung melalui pembaca kartu USB.
- Unit ini mungkin tidak bisa memutar file yang ada dalam USB dengan benar jika kabel sambungan USB digunakan.
- Unit ini tidak dapat menjamin fungsi yang baik atau memasok daya ke semua jenis perangkat.
- Unit ini dapat mengenali sebanyak 5 000 file dan 250 folder (maksimum 999 file per folder).
- Unit ini dapat mengenali sebanyak 25 karakter nama file/folder.

Bersambung ke halaman berikutnya

## Pengoperasian Bluetooth

### Umum

- Sewaktu mengemudi, jangan melakukan pengoperasian yang rumit seperti menyambungkan nomor, menggunakan buku telepon, dsb. Apabila melakukan pengoperasian ini, hentikan mobil Anda di tempat yang aman.
- Ada beberapa perangkat Bluetooth yang tidak dapat dihubungkan ke unit ini, bergantung versi perangkat Bluetooth yang digunakan.
- Unit ini tidak dapat berfungsi pada beberapa perangkat Bluetooth.
- Kondisi koneksi dapat beragam, bergantung keadaan di sekitar Anda.
- Apabila unit dimatikan, perangkat terputus.

### Pesan peringatan untuk pengoperasian Bluetooth

- **Connection Error:** Perangkat terdaftar tetapi koneksi gagal. Gunakan <Connect> untuk menghubungkan lagi perangkat. (☞ halaman 35)
- **Error:** Coba lakukan lagi. Jika "Error" [Kesalahan] muncul lagi, cek apakah perangkat mendukung fungsi yang Anda coba.
- **Device Unfound:** Tidak ada perangkat Bluetooth yang ditemukan <Search>.
- **Loading:** Unit sedang memperbarui buku telepon dan/atau SMS.
- **Please Wait...:** Unit sedang bersiap untuk menggunakan fungsi Bluetooth. Jika pesan tidak muncul, matikan dan hidupkan lagi unit, kemudian hubungkan kembali perangkat (atau setel ulang unitnya).
- **Reset 08:** Periksa sambungan antara adaptor dan unit ini.

## Ikon untuk jenis telepon

- Ikon-ikon ini menunjukkan jenis telepon yang disetel pada perangkat.



: Ponsel



: Telepon rumah



: Kantor



: Umum



: Selain yang di atas

## CD changer

- Jika memilih folder yang tidak berisi file musik apa pun, pada daftar (☞ halaman 41), Anda akan mendengar bunyi bip. Pilih folder lain yang berisi file musik.

## Pengoperasian iPod/D. player

- Apabila mengaktifkan unit ini, iPod atau D. player diisi muatan listrik melalui adaptor yang terhubung ke unit ini.
- Sewaktu iPod atau D. player terhubung, semua pengoperasian dari iPod atau D. player dinonaktifkan. Lakukan semua pengoperasian dari unit ini.
- Informasi teks mungkin tidak dapat ditampilkan dengan benar.
- Jika informasi teks menyertakan lebih dari 8 karakter, teks akan bergulir pada tampilan. Unit ini dapat menampilkan hingga 40 karakter.

### Pemberitahuan:

Sewaktu pengoperasian sebuah iPod atau sebuah D.player, beberapa pengoperasian mungkin tidak bisa dilakukan dengan benar atau sebagaimana mestinya. Jika ini terjadi, kunjungi situs web JVC berikut:

**Untuk pengguna iPod:** <<http://www.jvc.co.jp/english/car/support/ks-pd100/index.html>>

**Untuk pengguna D. player:** <<http://www.jvc.co.jp/english/car/support/ks-pd500/index.html>>

## Pengaturan menu

- Jika anda mengganti pengaturan <Amplifier Gain> dari <High> ke <Low> sementara tingkat level volume diatur lebih tinggi dari “30” alat penerima secara otomatis mengganti tingkat volume ke “VOL 30”.
- Setelah Anda mengubah <Menu Language/Audio Language/Subtitle> [Bahasa Menu/Bahasa Audio/ Teks film], matikan power dan masukkan kembali disk (atau masukkan disk yang lain) agar pengaturan Anda berlaku.
- Ketika anda memilih <16:9> untuk sebuah gambar yang rasio perbandingannya adalah 4:3, gambar berubah secara meramping karena proses konversi gambar melebar.
- Meskipun Anda memilih <4:3PS>, ukuran layar mungkin saja menjadi <4:3LB> untuk sejumlah disc.

- “DVD Logo” adalah merek dagang dari format DVD/ Badan Hukum Lisensi Logo yang terdaftar di Amerika, Jepang dan negara-negara lain.
- DivX, DivX Ultra Certified, dan logo-logo terkait adalah merek dagang dari DivX, inc. dan digunakan di bawah lisensi.
- Produk Bersertifikat Resmi DivX® Ultra
- Memutar semua versi video DivX® (termasuk DivX® 6) dengan memperluas pemutaran file media DivX® dan DivX® Media Format
- Microsoft dan Windows Media adalah baik merek dagang yang terdaftar maupun merek dagang dari Badan Hukum Microsoft di Amerika Serikat dan/atau negara-negara lain.
- Tanda kata dan logo Bluetooth dimiliki oleh Bluetooth SIG, Inc. dan segala penggunaan tanda tersebut oleh Victor Company of Japan, Limited (JVC) adalah berdasarkan lisensi. Merek dagang dan nama dagang lainnya adalah hak pemilik masing-masing.
- iPod dan iTunes adalah merek dagang dari Apple Inc., terdaftar di Amerika Serikat dan di negara-negara lain.
- Produk ini tergabung dalam teknologi perlindungan hak cipta yang dilindungi oleh paten Amerika dan hak cipta harus disahkan oleh Macrovision, dan diperuntukkan untuk rumah dan hanya penggunaan-penggunaan pemandangan terbatas yang lain kalau sebaliknya harus disahkan oleh Macrovision. Membalik keahlian tehnik atau pembongkaran adalah dilarang.

## Karakter diperlihatkan pada monitor

Selain abjad romawi (A – Z, a – z), dan <, (koma)>, dan <. (titik)>, karakter berikut akan digunakan untuk memperlihatkan berbagai informasi pada monitor.

- Anda juga dapat menggunakan karakter berikut untuk menetapkan judul. (☞ halaman 49).

Á	À	Â	Ã	Ä
Å	Æ	Ç	Ĉ	Ć
Ç	É	È	Ê	Ë
Ĝ	Í	Î	Ï	Ī
Ñ	Ó	Ô	Õ	Ö
Õ	Ø	Ř	Ŕ	Š
Š	Ş	Ú	Û	Ü
Û	Ý	Ž	Ẓ	Ẕ
Ẓ	Ẕ	Ẕ	Ẕ	Ẕ
ı	ı	ı		

á	à	â	ã	ä
å	æ	ç	ĉ	ć
ç	é	è	ê	ë
ĝ	í	î	ï	ī
ñ	ó	ô	õ	ö
ø	ř	ŕ	š	ş
ş	ú	û	ü	Û
Û	ý	ÿ	Ẓ	Ẕ
Ẓ	Ẕ	Ẕ	Ẕ	Ẕ
ı	ı	ı	ı	ı

0	1	2	3	4
5	6	7	8	9
!	"	#	\$	%
&	'	(	)	`
=	-	+	*	/
@	?	;	:	

Nomor-nomor dan simbol-simbol

Huruf besar dan huruf kecil

## Kode bahasa (untuk pemilihan bahasa DVD/DivX)

Kode	Bahasa	Kode	Bahasa	Kode	Bahasa	Kode	Bahasa	Kode	Bahasa
AA	Afar	FA	Persia	KL	Greenland	OC	Occitan	ST	Sesotho
AB	Abkhazian	FI	Finnish	KM	Kamboja	OM	(Afan) Oromo	SU	Sunda
AF	Afrikaans	FJ	Fiji	KN	Kannada	OR	Oriya	SW	Swahili
AM	Amharik	FO	Faroese	KO	Korean	PA	Panjabi	TA	Tamil
AR	Arab	FY	Frisian	KS	Kasmir	PL	Polandia	TE	Telugu
AS	Assamese	GA	Irish	KU	Kurdi	PS	Pashto, Pushto	TG	Tajik
AY	Aymara	GD	Scots Gaelic	KY	Kirghiz	PT	Portugis	TH	Thai
AZ	Azarbaijan	GL	Galician	LA	Latin	QU	Quechua	TI	Tigrinya
BA	Bashkir	GN	Guaran	LN	Lingala	RM	Rhueto-Romance	TK	Turkmen
BE	Belarusia	GU	Gujarati	LO	Laothian	RN	Kirundi	TL	Tagalog
BG	Bulgaria	HA	Hausa	LT	Lithuania	RO	Rumania	TN	Setswana
BH	Bihari	HI	Hindi	LV	Latvian, Lettish	RW	Kinyarwanda	TO	Tonga
BI	Bislama	HR	Kroasia	MG	Malagasi	SA	Sanskrit	TR	Turki
BN	Bengali, Bangla	HU	Hungaria	MI	Maori	SD	Sindhi	TS	Tsonga
BO	Tibet	HY	Armenia	MK	Makedonia	SG	Sangho	TT	Tatar
BR	Breton	IA	Interligua	ML	Malayualam	SH	Serbo-Kroasia	TW	Twi
CA	Catalan	IE	Interligue	MN	Mongolia	SI	Singhalese	UK	Ukraina
CO	Corsican	IK	Inupiak	MO	Maldovian	SK	Slovakia	UR	Urdu
CS	Czech	IN	Indonesia	MR	Marathi	SL	Slovenia	UZ	Uzbek
CY	Welsh	IS	Icelandic	MS	Melayu	SM	Samoa	VI	Vietnam
DZ	Butan	IW	Ibrani	MT	Maltese	SN	Shona	VO	Volapuk
EL	Yunani	JL	Yiddish	MY	Burma	SO	Somali	WO	Wolof
EO	Esperanto	JW	Jawa	NA	Nauru	SQ	Albania	XH	Xhoso
ET	Estonia	KA	Georgian	NE	Nepal	SR	Serbia	YO	Yoruba
EU	Basque	KK	Kazakh	NO	Norwegia	SS	Siswati	ZU	Zulu

Mode suara	Nilai-nilai ekualisasi yang telah diatur sebelumnya						
	60 Hz	150 Hz	400 Hz	1 kHz	2.5 kHz	6.3 kHz	15 kHz
Flat	00	00	00	00	00	00	00
Hard Rock	+03	+03	+01	00	00	+02	+01
R&B	+03	+02	+02	00	+01	+01	+03
Pop	00	+02	00	00	+01	+01	+02
Jazz	+03	+02	+01	+01	+01	+03	+02
Dance	+04	+02	00	-02	-01	+01	+01
Country	+02	+01	00	00	00	+01	+02
Reggae	+03	00	00	+01	+02	+02	+03
Classic	+02	+03	+01	00	00	+02	00
User 1/2/3	00	00	00	00	00	00	00

### Mengenai suara-suara yang dihasilkan melalui terminal-terminal belakang

- Speaker out/analog Diskrete output—LINE OUT (FRONT/REAR)/CENTER OUT/SUBWOOFER: Sinyal multi-channel dipancarkan untuk perangkat lunak yang disandi untuk multi-channel [multi saluran]. (Apabila Dual Zone (Zona Dual) diaktifkan, sinyal yang terpancar melalui steker 2nd AUDIO OUT, dipancarkan untuk "DISC" sumber utama.)
- 2nd AUDIO OUT: Sinyal 2-saluran dipancarkan apabila Dual Zone (Zona Dual) diaktifkan. Apabila memutar disk berkode multi-saluran, sinyal multi-saluran di-downmix (kecuali untuk sejumlah DVD Audio).

## Pemecahan masalah

Apa yang muncul dan menjadi masalah tidak selalu serius. Cek poin-poin berikut sebelum memanggil sebuah pusat layanan.

- Untuk pengoperasian dengan komponen eksternal, rujuk juga ke petunjuk yang dibekalkan bersama adaptor yang digunakan untuk koneksi (serta petunjuk yang dibekalkan bersama komponen eksternal)

	Gejala-gejala	Perbaikan-perbaikan/Sebab-sebab
Umum	<ul style="list-style-type: none"><li>• Tidak ada suara yang keluar dari speaker tengah.</li></ul>	<ul style="list-style-type: none"><li>• Pengeras suara tengah tidak diaktifkan. (☞ halaman 54)</li><li>• Speaker tengah hanya digunakan untuk pemutaran surround. Tidak ada suara yang keluar untuk pemutaran stereo.</li></ul>
	<ul style="list-style-type: none"><li>• Tidak ada suara yang keluar dari pengeras suara belakang dan subwoofer.</li></ul>	<ul style="list-style-type: none"><li>• Pengeras suara belakang dan subwoofer tidak diaktifkan. (☞ halaman 54)</li><li>• Apabila Dual Zone (Zona Dual) digunakan, ini normal jika &lt;Off&gt; dipilih untuk &lt;Rear Speaker&gt;. (☞ halaman 57)</li></ul>
	<ul style="list-style-type: none"><li>• Tidak ada suara yang keluar dari subwoofer sewaktu memutar dalam stereo.</li></ul>	Ini terjadi sewaktu memutar beberapa disc di mana <Auto> dipilih untuk <Surround Mode> (☞ halaman 24). Membatalkan surround.
	<ul style="list-style-type: none"><li>• Monitor tidak jelas dan tidak terbaca.</li></ul>	Mungkin, sinar matahari dari kaca depan yang menyebabkan gejala ini. Sesuaikan <Bright>. (☞ halaman 51)
	<ul style="list-style-type: none"><li>• Anda tidak dapat memilih "SD" dan "USB" sebagai sumber utama.</li></ul>	Menon-aktifkan Dual Zone (Zona Dual). (☞ halaman 27) (Sewaktu Dual Zone (Zona Dual) diaktifkan, Anda tidak dapat memilihnya sebagai sumber.)
	<ul style="list-style-type: none"><li>• Remote control tidak bekerja.</li></ul>	Menon-aktifkan Dual Zone (Zona Dual). (☞ halaman 27) (Ketika Dual Zone (Zona Dual) telah diaktifkan, remote control hanya berfungsi untuk mengoperasikan pemutar DVD/CD.)
	<ul style="list-style-type: none"><li>• "Position Error Push Open Key" muncul pada monitor.</li></ul>	Sudut panel monitor sudah disesuaikan secara paksa, atau terganggu sewaktu membuka atau menutup. Tekan OPEN/TILT (CLOSE).
	<ul style="list-style-type: none"><li>• "Mecha Error Push Reset" muncul di monitor dan panel tidak bergerak.</li></ul>	Reset alat penerima (☞ halaman 3).
	<ul style="list-style-type: none"><li>• "SD Loading Error" muncul pada monitor.</li></ul>	SD tidak sepenuhnya dimasukkan. Masukkan kartu sepenuhnya ke dalam slot agar panel monitor dapat ditutup.

	Gejala-gejala	Perbaiki-perbaiki/Sebab-sebab
Umum	<ul style="list-style-type: none"> <li>• “No Signal” muncul.</li> </ul>	<ul style="list-style-type: none"> <li>• Ganti sumber.</li> <li>• Jalankan pemutaran pada komponen eksternal yang terhubung ke steker VIDEO IN.</li> <li>• Cek kabel-kabel dan penyambungan-penyambungan.</li> <li>• Input sinyal terlalu lemah.</li> </ul>
	<ul style="list-style-type: none"> <li>• Tombol pada panel monitor tidak berfungsi.</li> </ul>	<p>Apabila panel monitor terbuka, maka hanya tombol VOL +/- dan OPEN/TILT (CLOSE) yang berfungsi. Tombol lainnya tidak berfungsi.</p>
	<ul style="list-style-type: none"> <li>• Alat penerima tidak bekerja secara keseluruhan.</li> </ul>	<p>Reset alat penerima. (☞ halaman 3)</p>
FW/AM	<ul style="list-style-type: none"> <li>• Pengaturan otomatis SSM tidak berfungsi.</li> </ul>	<p>Simpan stasiun-stasiun secara manual. (☞ halaman 11)</p>
	<ul style="list-style-type: none"> <li>• Noise (Derau) statis sementara mendengarkan radio.</li> </ul>	<p>Kencangkan sambungan antena.</p>
Disc secara umum	<ul style="list-style-type: none"> <li>• Disk tidak dapat dikenali maupun diputar.</li> </ul>	<p>Keluarkan disk secara paksa. (☞ halaman 3)</p>
	<ul style="list-style-type: none"> <li>• Disk tidak dapat dikeluarkan.</li> </ul>	<p>Buka kunci disk. (☞ halaman 19)</p>
	<ul style="list-style-type: none"> <li>• Disk Recordable/Rewritable tidak dapat diputar kembali.</li> <li>• Trek pada disk Recordable/Rewritable tidak dapat diloncati.</li> </ul>	<ul style="list-style-type: none"> <li>• Masukkan disk yang telah selesai.</li> <li>• Selesaikan disk dengan komponen yang anda gunakan untuk merekam.</li> </ul>
	<ul style="list-style-type: none"> <li>• Pemutaran tidak mau memulai.</li> </ul>	<ul style="list-style-type: none"> <li>• Masukkan lagi disk dengan benar.</li> <li>• Format file tidak didukung oleh unit.</li> </ul>
	<ul style="list-style-type: none"> <li>• Gambar pemutaran tidak jelas dan tidak terbaca.</li> </ul>	<p>Sesuaikan item dalam &lt;Picture Adjust&gt;. (☞ halaman 51)</p>
	<ul style="list-style-type: none"> <li>• Suara dan gambar kadang-kadang diinterupsi atau didistorsi.</li> </ul>	<ul style="list-style-type: none"> <li>• Hentikan putar ulang sementara mengemudi pada jalan yang kasar.</li> <li>• Ganti disk tersebut.</li> </ul>
	<ul style="list-style-type: none"> <li>• Tidak ada gambar permainan-ulang yang muncul di monitor.</li> </ul>	<p>Timbal rem parkir tidak terhubung dengan benar. (☞ Manual Pemasangan/ Penyambungan)</p>
	<ul style="list-style-type: none"> <li>• Sama sekali tidak ada gambar yang muncul pada monitor eksternal.</li> </ul>	<ul style="list-style-type: none"> <li>• Sambungkan kabel video dengan benar.</li> <li>• Pilih input yang benar pada monitor eksternal.</li> </ul>
	<ul style="list-style-type: none"> <li>• “Eject Error” atau “Loading Error” muncul pada monitor.</li> </ul>	<p>Mengubah sumber dengan menekan SOURCE akan mengatasi kesalahan ini.</p>
	<ul style="list-style-type: none"> <li>• “Region code error” muncul di monitor apabila Anda memasukkan DVD Video.</li> </ul>	<p>Kode region salah. (☞ halaman 4)</p>

	Gejala-gejala	Perbaikan-perbaikan/Sebab-sebab
Dix/MP3/MP2/JPEG/MP3/WMA/WAV/AAC	• Disk tidak dapat diputar ulang.	<ul style="list-style-type: none"> <li>• Ganti disk tersebut.</li> <li>• Rekam trek dengan menggunakan aplikasi sesuai standar dalam disk yang sesuai. (☞ halaman 4)</li> <li>• Tambah kode ekstension yang sesuai pada nama file.</li> </ul>
	• Noise dikuatkan.	Trek yang diputar bukan merupakan format file yang dapat diputar. Lompati dan langsung ke file lainnya.
	• Trek tidak dapat diputar seperti yang Anda kehendaki.	Urutan pemutaran dapat berbeda dari yang diputar dengan menggunakan player lain.
	• Putar yang telah lewat tidak benar.	Kadang-kadang ini terjadi sewaktu pemutaran. Hal ini disebabkan bagaimana trek-trek telah direkam.
	• “Not Support” [Tidak Terdukung], muncul di monitor dan trek dilompati.	Trek ini tidak dapat diputar.
SD/USB	• Noise dikuatkan.	Trek yang diputar bukan merupakan format file yang dapat diputar. Lompati dan langsung ke file lainnya.
	• Trek tidak dapat diputar seperti yang Anda harapkan.	Urutan pemutaran dapat berbeda dari yang diputar dengan menggunakan player lain.
	• “Now Reading...” tetap berkedip pada monitor.	<ul style="list-style-type: none"> <li>• Waktu baca beragam, tergantung kartu SD/perangkat USB yang digunakan.</li> <li>• Jangan menggunakan terlalu banyak hirarki-hirarki dan folder-folder.</li> <li>• Matikan daya, kemudian hidupkan lagi.</li> </ul>
	• Karakter-karakter yang benar tidak ditampilkan (misalnya nama album).	Untuk melihat karakter yang tersedia, ☞ halaman 65.
	• Sewaktu memutar trek, kadang-kadang suaranya terputus.	Trek tidak tersalin dengan benar ke dalam kartu SD/perangkat USB. Salin lagi trek tersebut lalu coba kembali.

	Gejala-gejala	Perbaiki-perbaiki/Sebab-sebab
Bluetooth	• Perangkat Bluetooth tidak mendeteksi unit.	Unit ini dapat dihubungkan dengan satu ponsel Bluetooth dan satu perangkat audio Bluetooth secara bersamaan. Sewaktu menghubungkan perangkat, unit ini tidak dapat terdeteksi dari perangkat yang lain. Putuskan perangkat yang sekarang terhubung lalu cari lagi.
	• Unit tidak mendeteksi perangkat Bluetooth.	<ul style="list-style-type: none"> <li>• Cek pengaturan perangkat Bluetooth.</li> <li>• Cari dari perangkat Bluetooth. Setelah perangkat mendeteksi unit, pilih &lt;Open&gt; pada unit untuk menghubungkan perangkat. (☞ halaman 34)</li> </ul>
	• Unit tidak melakukan pairing dengan perangkat Bluetooth.	<ul style="list-style-type: none"> <li>• Masukkan kode PIN yang sama untuk unit dan perangkat sasaran. Jika kode PIN perangkat tidak diindikasikan pada petunjuknya, cobalah "0000" atau "1234".</li> <li>• Pilih nama perangkat dari &lt;Special Device&gt;, lalu coba hubungkan lagi. (☞ halaman 35, 58)</li> </ul>
	• Terdengar bunyi echo atau desis.	Sesuaikan posisi unit mikrofon.
	• Kualitas suara telepon buruk.	<ul style="list-style-type: none"> <li>• Perpendek jarak antara unit dan perangkat audio Bluetooth.</li> <li>• Pindahkan mobil ke tempat di mana Anda dapat menerima sinyal yang lebih baik.</li> </ul>
	• Suara terputus atau terlompati sewaktu pemutaran perangkat audio Bluetooth.	<ul style="list-style-type: none"> <li>• Perpendek jarak antara unit dan perangkat audio Bluetooth.</li> <li>• Putuskan perangkat yang terhubung ke "Bluetooth PHONE".</li> <li>• Matikan kemudian hidupkan kembali unitnya.</li> <li>• (Apabila suara belum terpulihkan), hubungkan lagi perangkat.</li> </ul>
	• "New Device" [Perangkat Baru] tidak bisa dipilih untuk "Bluetooth AUDIO".	Perangkat audio Bluetooth sedang dihubungkan. Untuk memilih "New Device" [Perangkat Baru], lepaskan perangkatnya. (☞ halaman 35)
	• Perangkat audio yang terhubung tidak dapat dikendalikan.	Cek apakah perangkat audio yang terhubung mendukung AVRCP (Audio Video Remote Control Profile).
	• "Reset 08" muncul pada monitor.	Periksa sambungan antara adaptor dan unit ini.
	CD changer	• "No Disc" muncul pada monitor.
• "No Magazine" muncul pada monitor.		Sisipkan tempat CD.
• "Cannot play this disc Check the disc" muncul pada monitor.		Di dalam disk tidak ada file yang dapat diputar. Ganti disk dengan disk lain yang berisi file yang dapat diputar.
• "Reset 08" muncul pada monitor.		Sambungkan alat penerima ini dan CD changer secara benar dan tekan tombol reset dari CD changer.
• "Reset 01" – "Reset 07" muncul pada monitor.		Tekan tombol reset dari CD changer.
• CD changer tidak berfungsi sama sekali.		Reset alat penerima. (☞ halaman 3)

	Gejala-gejala	Perbaikan-perbaikan/Sebab-sebab
iPod/D. player	<ul style="list-style-type: none"> <li>iPod atau D. player tidak hidup atau tidak berfungsi.</li> </ul>	<ul style="list-style-type: none"> <li>Periksalah kabel penghubung dan sambungannya.</li> <li>Isikan baterai.</li> <li>Untuk D. player: Mutakhirkan versi firmware.</li> </ul>
	<ul style="list-style-type: none"> <li>Suara mengalami distorsi.</li> </ul>	Dinonaktifkan equalizer pada unit atau iPod/ D.player.
	<ul style="list-style-type: none"> <li>“Disconnect” muncul pada monitor.</li> </ul>	Periksalah kabel penghubung dan sambungannya.
	<ul style="list-style-type: none"> <li>Untuk iPod: Pemutaran berhenti.</li> </ul>	Headphone akan terputus selama pemutaran. Mulaikan lagi pemutaran.
	<ul style="list-style-type: none"> <li>Tidak ada suara yang terdengar.</li> <li>“Error 01” muncul pada monitor D.player terhubung.</li> </ul>	Cabut adaptor dari D. player. Lalu, hubungkan lagi.
	<ul style="list-style-type: none"> <li>“No Files” atau “No Track” muncul pada monitor.</li> </ul>	Tidak ada trek yang disimpan. Impor trek ke iPod atau D. player.
	<ul style="list-style-type: none"> <li>“Reset 01” – “Reset 07” muncul pada monitor.</li> </ul>	Lepaskan adaptor dari kedua-dua unit dan iPod/D.player. Lalu, hubungkan lagi.
	<ul style="list-style-type: none"> <li>“Reset 08” muncul pada monitor.</li> </ul>	Periksa sambungan antara adaptor dan unit ini.
AV-IN	<ul style="list-style-type: none"> <li>Kontrol iPod atau D. player tidak berfungsi setelah diputuskan dari unit ini.</li> </ul>	Reset iPod atau D. player.
	<ul style="list-style-type: none"> <li>Tidak ada gambar yang muncul pada monitor.</li> <li>Gambar pemutaran tidak jelas dan tidak terbaca.</li> </ul>	<ul style="list-style-type: none"> <li>Hidupkan komponen video jika belum dinyalakan.</li> <li>Unit ini tidak tersambung ke komponen video dengan benar. Sambungkan yang benar.</li> </ul> <p>Sesuaikan item dalam &lt;Picture Adjust&gt;. (☰ halaman 51)</p>

# Spesifikasi-spesifikasi

AMPLIFIER	Maksimum keluaran power:	Depan/Belakang:	50 W per saluran
	Output Power Kontinu (RMS):	Depan/Belakang:	20 W per saluran dalam 4 $\Omega$ , 40 Hz sampai 20 000 Hz pada tidak lebih dari 0.8% total distorsi harmonis
	Impedansi Beban:		4 $\Omega$ (kelonggaran 4 $\Omega$ sampai 8 $\Omega$ )
	Cakupan Kontrol Ekuhaliser:	Frekuensi-frekuensi:	60 Hz, 150 Hz, 400 Hz, 1 kHz, 2.5 kHz, 6.3 kHz, 15 kHz
		Level (Tingkat):	$\pm 10$ dB
	Perbandingan Sinyal ke derau:		70 dB
	Audio Output Level LINE OUT (FRONT/REAR)/ CENTER OUT/ SUBWOOFER:	Tingkat Line-Out/Impedansi:	5.0 V/20 k $\Omega$ beban (skala penuh)
		Impedansi Output:	1 k $\Omega$
	Sistem Warna:		NTSC/PAL
	Output video (composite):		1 Vp-p/75 $\Omega$
Terminal Lain:	Input:	LINE IN, VIDEO IN, CAMERA IN, Terminal masukan USB, Antena input	
	Output:	2nd AUDIO OUT, VIDEO OUT	
	Lain-Lain:	CD changer	
TUNER FM/AM	Cakupan Frekuensi:	FM:	87.5 MHz sampai 108.0 MHz
		AM:	531 kHz sampai 1 602 kHz
	Tuner FM	Sensitivitas yang dapat digunakan:	11.3 dBf (1.0 $\mu$ V/75 $\Omega$ )
		50 dB Sensitivitas Peredaan:	16.3 dBf (1.8 $\mu$ V/75 $\Omega$ )
		Selektifitas Saluran Alternatif (400 kHz):	65 dB
		Respon Frekuensi:	40 Hz sampai 15 000 Hz
		Pemisahan Stereo:	35 dB
Tuner AM	Sensitivitas/Selektifitas:	20 $\mu$ V/35 dB	
DVD/CD	Sistem Pendeteksi Sinyal:	Optik non kontak terbuka (laser semikonduktor)	
	Respon Frekuensi:	DVD, fs=48 kHz:	16 Hz sampai 22 000 Hz
		DVD, fs=192 kHz:	16 Hz sampai 88 000 Hz
		VCD/CD:	16 Hz sampai 20 000 Hz
	Cakupan Dinamik:		93 dB
	Perbandingan Sinyal ke derau:		95 dB
Wow dan Flutter:		Kurang dari batas ukuran	

SD	Sistem File Kompatibel:	FAT 32/16/12		
	Kapasitas	8 Mbyte hingga 2 Gbyte		
	Laju Transfer Data	Maksimum 10 Mbps		
USB	Standar USB:	USB 1.1		
	Laju Transfer Data	Kecepatan Penuh: Maksimum 12 Mbyte Kecepatan Rendah: Maksimum 1.5 Mbyte		
	Perangkat Kompatibel:	Kelas penyimpanan massal		
	Sistem File Kompatibel:	FAT 32/16/12		
	Arus Maks.:	Kurang dari 500 mA/5V		
MONITOR	Ukuran Layar:	7 inci tampilan lebar kristal cair		
	Jumlah elemen gambar:	336 960 elemen gambar: 480 × 3 (horisontal) × 234 (vertikal)		
	Drive method [Metode gerakan]:	TFT (Transistor Film Tipis) format aktif matriks		
	Sistem warna:	NTSC/PAL		
	Rasio perbandingan:	16:9 (lebar)		
UMUM	Power yang Diperlukan:	Voltase Pengoperasian:	DC 14.4 V (kelonggaran 11 V sampai 16 V)	
	Sistem Pertanahan:	Tanah negatif		
	Temperatur penyimpanan yang diizinkan:	-10°C sampai +60°C		
	Temperatur pengoperasian yang diizinkan:	0°C sampai +40°C		
	Dimensi (L × T × T):	Ukuran instalasi (kira-kira):	178 mm × 100 mm × 160 mm	
		Ukuran panel (kira-kira):	171 mm × 97 mm × 21 mm	
	Massa (kira-kira):	2.7 kg (termasuk trim dan sleeve)		

### Ruang pengeluaran monitor yang dibutuhkan

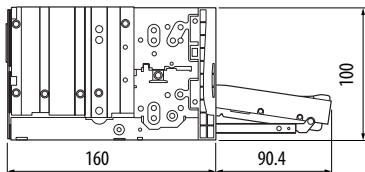

**PERHATIAN:** Ketika mengeluarkan monitor, tetap berikan ruang terbuka untuk monitor menutup. Jika tidak, monitor mungkin menghalangi sistem kemudi stir dan tingkat pengoperasian perpindahan gigi, dimana ini mungkin menyebabkan kecelakaan lalu lintas.

Unit: mm



**Having TROUBLE with operation?**

**Please reset your unit**

Refer to page of How to reset your unit

**Ada MASALAH dengan cara  
pengoperasian?**

**Setel kembali unit Anda**

Lihat halaman mengenai Bagaimana mereset unit anda

**JVC**



EN, IN

© 2007 Victor Company of Japan, Limited

0207MNMDWJEIN

**JVC**

**Instructions**

**DVD RECEIVER WITH MONITOR**

**KW-AVX800**